

DECLASSIFIED

SPOTU  
Composites Section

30362

OS 9-69

SKINNER

# ORDNANCE

SCHOOL TEXT

# ROCKETS AND LAUNCHERS ALL TYPES

FEBRUARY 1944



DECLASSIFIED

*Prepared by*

**THE ORDNANCE SCHOOL**  
ABERDEEN PROVING GROUND, MARYLAND

ROCKETS AND LAUNCHERS, ALL TYPES OS 9-69  
M  
614  
G9  
D

**DECLASSIFIED**

THE COMMAND AND STAFF COLLEGE  
LIBRARY

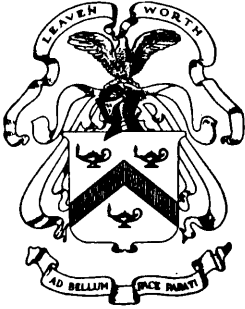

Class Symbol M 614-G9-D

Accession Number N 73504

edient pending the  
operation of the information contained herein in an  
approved War Department manual.

**DECLASSIFIED**

DECLASSIFIED

ORDNANCE SCHOOL TEXT  
No. 9-69

OS 9-69

THE ORDNANCE SCHOOL  
Aberdeen Proving Ground, February 1944

████████████████████  
DOWNGRADED AT 3 YEAR INTERVALS;  
DECLASSIFIED AFTER 12 YEARS.  
DOD DIR 5200.10

# ROCKETS AND LAUNCHERS,

## ALL TYPES

Prepared under the direction of  
the Commandant, The Ordnance School

### CONTENTS

CHAPTER	Paragraph	Page
1. General -----	1	3
2. 2.36" Rockets -----	10	9
3. 3.25" Target Rockets -----	61	50
4. 4.5" Rockets and Launchers -----	65	52
5. 7.2" Rockets and Launchers -----	94	90
6. 8" Rockets -----	113	111
7. 10" Rockets -----	114	112

# DECLASSIFIED

**DECLASSIFIED**

P R E L I M I N A R Y   P R I N T I N G

for limited distribution and subject to correction. Students are urged to add material as it becomes available and make whatever corrections are necessary. Blank pages for this purpose are available in sections concerned with new items.

**DECLASSIFIED**

## ROCKETS AND LAUNCHERS, ALL TYPES

### CHAPTER 1—GENERAL

#### 1 PURPOSE

This text is published for use in courses at The Ordnance School.

#### 2 SCOPE

Chapter 1 covers material common to all rockets, such as the theory of flight, the history of rockets, and their advantages and disadvantages. Succeding chapters are concerned with the various standard and development rockets, with a chapter assigned to each size of rocket.

#### 3 REFERENCES

Information included in this text has been secured from the following publications:

a. Standard Nomenclature List S-9, Rockets, All Types, and Components.

b. Training Circular No. 104, Antitank Rocket, 2.36", M6 and M7, and Launcher, dated 15 December 1942.

c. Technical Manuals:  
TM 9-390, Target Rocket Projector, M1; TM 9-393, 4.5-Inch Artillery Rocket Launcher, T35, and 4.5-Inch H.E. Rocket, M8; TM 9-395, 4.5" Rocket Materiel.

d. Minutes of the Ordnance Technical Committee.

#### 4 HISTORY OF ROCKETS

a. The rocket has from early times attracted attention for military purposes, first in Asia and later in Europe and America. No great progress was made until the beginning of experiments by a William Congreve. Congreve extended the work of General Desaguliers, who was in charge of the famous Woolwich laboratory in England. Congreve set himself the task of producing a rocket capable of carrying an incendiary or explosive charge and having a range up to 2 miles. After some preliminary trials he was given permission to utilize the Royal Laboratory to construct rockets of his own design. The results obtained were so promising that in 1805 Sir Sydney Smith's expedition against Boulogne included boats especially fitted for salvo firing of rockets. Rough weather prevented their use on that occasion, but the following year they were used against the same place and, although deflected by a strong wind from the fortifications, which were their objective, they did considerable damage in the town itself.

b. In 1812 the Field Rocket Brigade was formed and was ordered to join the Allies before Leipzig. Captain Bogue of the Horse Artillery, the only English officer present, was made the commander. The effect of the rockets on this occasion -- the first time they had ever been used in European

land warfare — was very marked. The Rocket Brigade also distinguished itself 3 years later at Waterloo.

c. During most of the 19th century, rockets carried an important share of artillery functions, although they did not come within measurable distance of superseding artillery, as Congreve in his enthusiasm had predicted. With the development of rifling, breechloading, independent recoil, and smokeless powder, the advantages claimed for rockets were discounted, and they were declared obsolete by the end of the century.

d. One of the first American proponents of rockets was Edwin Taylor, who, prior to and during the Spanish-American War, advocated the use of rockets to propel shells filled with dynamite and nitroglycerine. At that time these charges were too sensitive to withstand the high acceleration produced by a gun.

e. At the beginning of World War II, little interest was shown in rockets by the armed forces of this country. With the development of a successful antiaircraft rocket by the British, however, research was begun on a large scale. Work in the Ordnance Department on rockets as military projectiles using available modern propellants was begun on a small scale at Aberdeen Proving Ground, Maryland, by Col. L. A. Skinner in 1932. Much of the basic information which he secured has been of great assistance in the large-scale development which commenced in October 1942.

**5 THEORY OF FLIGHT**

a. Method of propulsion. — If, in a system of forces acting against each other, the forces are unbalanced (i.e., one of the forces is greater than the other), movement will proceed in the direction of the greater force. If gas is placed under pressure in a tube closed at one end, a system of unbal-

anced forces is set up which can result in movement of the tube. Figure 1 illustrates such an arrangement in its simplest aspect and indicates how a rocket secures propulsion. It will be noted that the pressure is applied in all directions (at the moment of maximum pressure of the gas). The arrows indicate the forces exercised by the pressure, and the length of each arrow indicates the magnitude of each force. The forces near the open end of the tube are smaller, because the gas has less pressure at that point. The forces acting on the walls of the tube cancel

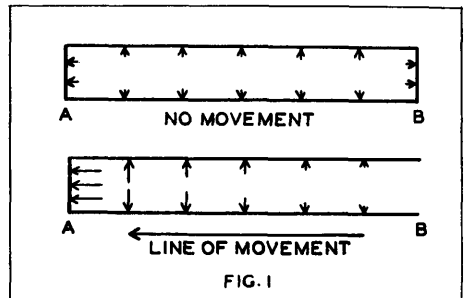

each other, and the tube moves forward as a result of the force applied to the closed end of the tube. When the gas has escaped from the tube and the pressure outside the tube is the same as the pressure inside the tube, no force remains to move the tube forward.

b. Semiclosed end. — It is apparent that with the open-end tube the gas escapes rapidly, making a high pressure difficult to attain or maintain. By partially closing one end, a new situation occurs, as diagrammed in figure 2. (The pressure of the gas,

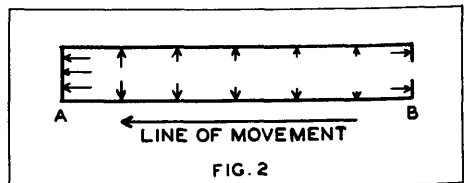

acting as a force against the walls of the tube, is now, for the sake of explanation, everywhere equal). The forces acting against the walls cancel each other as before. In addition, the

forces acting against the semiclosed end B of the rocket cancel the forces acting against an equal area of the fully closed end A. Since the tube is partially closed, a greater pressure is achieved and the resulting force on the effective area of end A is greater than heretofore. The force acting against the end A may be measured in terms of the area of the aperture in the end B and the pressure of the gas. The smaller the aperture, the greater the pressure of the gas, but at the same time, the smaller the aperture, the greater the force applied to the effective area of the end A. A great many complications enter the theory of flight at this point, but, for the sake of a basic explanation, they will be ignored.

c. Introduction of the nozzle.—

(1) Forward half.— By tapering the end

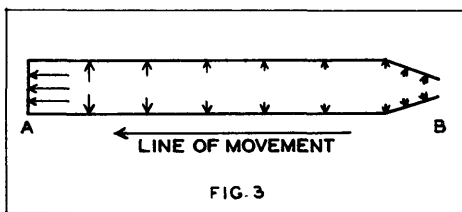

B to the rear, the pressure of the gas is not changed, but a smooth, nonturbulent flow of escaping gas is created. This tapered section forms the forward half of the nozzle.

(2) Rear half.— If an extension which expands from the aperture is added to the nozzle, a system of forces which give a forward thrust to the tube is set up. Figure 4 illustrates how this is accomplished. There are prac-

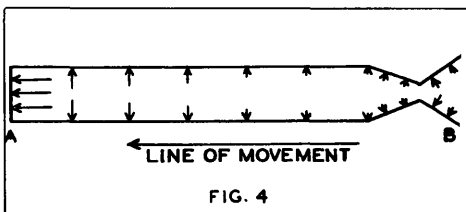

tical limits to the length of this expansion as well as to the angle at which the expansion develops. In general, it may be said that the expanding part

should be as long as possible in order to secure the maximum forward thrust and should diverge as rapidly as possible, but not so rapidly as to allow the flow of gas to leave the surface of the walls.

## 6 DESIGN

a. Terminology.— A rocket consists, in general, of several components. (See fig. 6.) The explosive head is the forward part of the complete round that contains the explosive charge. The motor is the tube that contains the propellant, which upon ignition produces the necessary gases. The  fins are the attachments that stabilize the rocket in flight. The nozzle is the exit vent for the motor gases. The explosive head is usually placed at the front end of the rocket. The motor is attached to the base of the head. The nozzle is at the rear end of the motor, and the fins are attached externally at the same place. This terminology is not used to designate the component parts of any particular standard rocket but is reserved for discussions of rockets in general.

b. Explosive head.— Explosive heads for the various standard rockets differ considerably in shape but always have a streamlined appearance.

c. Motor.— The motor for all standard rockets is a tube. The walls of the tube have sufficient strength to withstand the anticipated pressures resulting from the burning of the propellant. A balance must be struck between the weight of the motor (the thickness of its walls) and the pressure that is to be achieved. A maximum pressure is desirable, but excessive motor weight will materially reduce the effective flight of the rocket.

d. Nozzle.— The development of the most efficient nozzle is still in process. At present the nozzle is a smooth piece in the form of a venturi. The forward curve is smooth and has a long radial distance. The rear por-

## ROCKETS GENERAL

tion of the venturi develops at an angle of approximately  $20^\circ$ , the limit best suited to secure the maximum thrust.

e. Fins.— The fins vary in shape with the different rockets.

f. Propellant.— The development of a suitable propellant for rockets has been a difficult process. At present a propellant powder in stick form is used. This powder, which is ballistite, burns slowly and evenly, providing the maximum allowable pressure. The rate at which the powder burns (which is a determining factor of pressure) is determined by many factors. One of these is the diameter of the nozzle, which regulates the rate of escape of the gas. If the gas fails to escape at the proper rate, the pressure within the motor increases. As this internal pressure builds up, the rate of burning of the propellant will increase, further increasing the pressure until the wall strength of the motor is exceeded. The composition and the rate of burning of the propellant, then, affect not only the design of the nozzle but also the thickness of the motor. It may be seen that the balance to be achieved between the various components is a delicate one.

### 7 ADVANTAGES AND LIMITATIONS

#### a. Applications of rockets.

(1) Rockets are of great importance because they produce no recoil. The lack of recoil permits their use on airplanes and small boats and on light tanks, cars, motorcycles and other vehicles incapable of withstanding large recoil forces. It also permits the firing of grenades and explosive charges from a tube held in the hands.

(2) Another feature of rockets that gives them military importance is the relative lightness of the projector in comparison with a gun firing ammunition of equal weight. This permits fire to be delivered from areas to which guns and howitzers cannot be transported.

(3) Lack of recoil is an important consideration, for it gives wide latitude in the selection of mounts and missiles. The mount may be of more delicate construction than is possible with a gun of equal caliber; missiles that cannot withstand gun acceleration can be projected rocket fashion. Absence of recoil has also permitted the development of sensitive and efficient fuzes.

(4) Of tremendous importance in considering the advantages of rockets are the ease and cheapness of manufacture of the launcher in comparison with the complexity and high cost of a gun. The rocket launcher is simply a guide and consists either of a tube or parallel tracks.

b. Advantages of rockets.— The advantages of rockets, then, may be summarized as follows:

(1) Absence of recoil.

(2) Accelerations that are not excessive and that are easily controlled.

(3) Need for only a light, inexpensive, easily mass-manufactured guide launcher.

c. Limitations of rockets.— The following disadvantages limit the application of rockets.

(1) The dangers resulting from the blast of the gases escaping through the nozzle.

(2) Decreased accuracy in comparison with a gun.

### 8 USES

At the present time there are five kinds of rockets. They are classified for use as follows:

a. Antitank.— The antitank rocket is fired from the shoulder for effective action against armored vehicles and hard-surfaced materials.



### b. Antiaircraft target rocket.

This rocket is fired from a special launcher to simulate the flight of low-flying aircraft in order to provide anti-aircraft gun crews with a more accurate conception of combat firing.

### c. Artillery and aircraft artillery.

This rocket is used in much the same manner as artillery in general and with the same mission. As aircraft artillery, it is fired from planes against other planes and from planes against ground targets.

d. Practice.— These rockets are fired to simulate the firing of high-explosive rockets, to which they correspond, without the danger or expense of firing the latter.

e. Chemical.— These rockets project smoke and other chemical agents.

## 9 ROCKETS

a. Listing.— The following rockets are issued to the service:\*

- (1) Rocket, H.E., AT, 2.36", M6A1.
- (2) Rocket, practice, 2.36", M7A1.
- (3) Rocket, target, A.A., 3.25", M2.
- (4) Rocket, H.E., 4.5", M8 w/Fuze, P.D., M4.
- (5) Rocket, practice, 4.5", M9 w/dummy fuze.

### b. Characteristics.

— All the above rockets are projected from launchers with either rails or a tube to serve as a guide. As the function of rockets vary, their design varies accordingly, but all have the motor, nozzle, and fins at the rear.

### c. Painting.

— The rockets having a high-explosive content are painted olive drab; those having inert heads are painted blue. Painting will be discussed in more detail in the section devoted to each particular rocket.

### d. Packing.

— Packing will be discussed in the sections devoted to each particular rocket.

### e. General safety precautions.

(1) A distinctive feature of rockets is the blast at the base of the launcher when the rocket is being projected. Personnel are warned to stay clear of the blast area, for this blast is highly destructive.

(2) All rockets should be stored at a temperature that does not exceed the temperature range specified for the rocket. No rounds should be left exposed to the direct rays of the sun for any length of time in order to avoid heating the powder to a temperature above that at which the rocket is designed to operate. Local conditions will govern the type of storage place that is supplied. The several temperature limits have been carefully determined for these rounds, and these limits should not be exceeded.

\*The nomenclature of the rockets listed is correct and complete. However, in the interest of brevity it will be shortened throughout the following discussions. Modifications are occurring rapidly, and therefore the above list is subject to change.

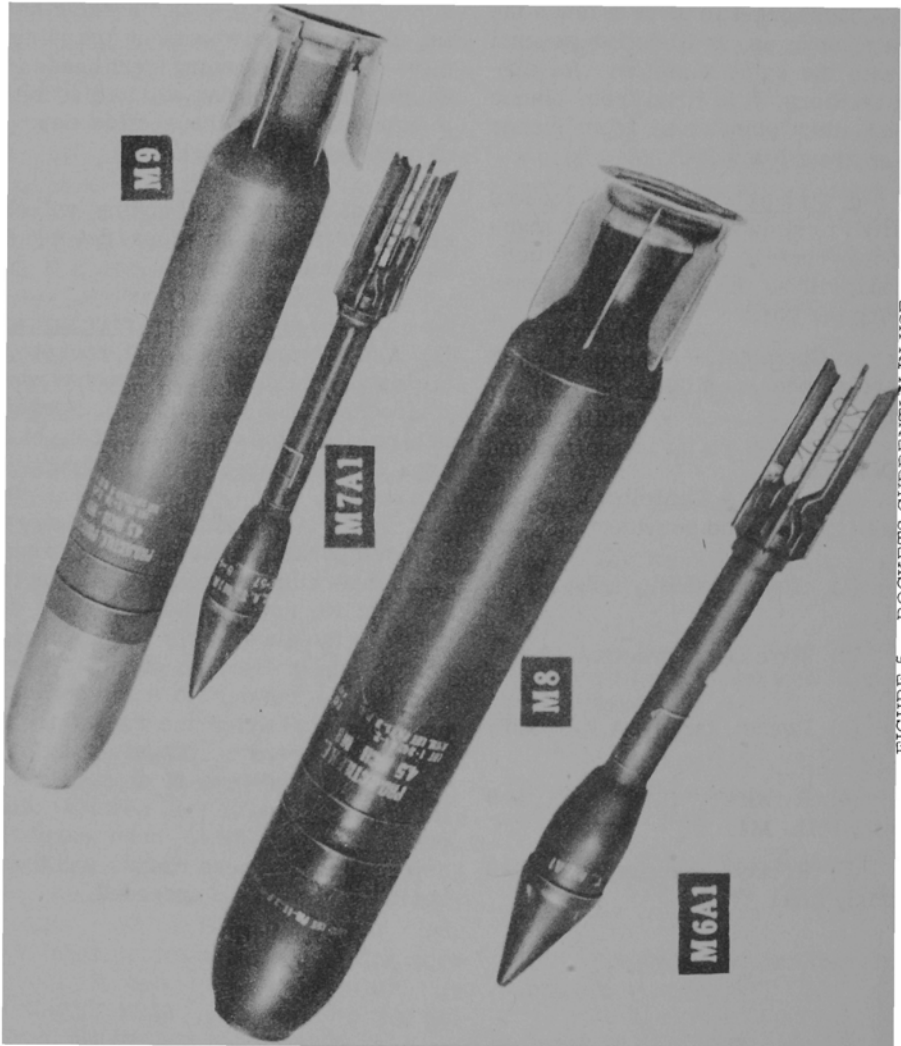

FIGURE 5. - ROCKETS CURRENTLY IN USE

## CHAPTER 2—2.36" ROCKETS

## SECTION I

## ROCKET, H.E., AT, 2.36", M6A1

## 10 GENERAL

a. Description.— The antitank rocket, 2.36", M6A1, is both an offensive and defensive weapon. In both types of action, it is used primarily to fire upon hostile armored vehicles which come within effective range. It is essentially a weapon of opportunity. It is 21.6" long and weighs 3.5 lb. It has a relatively low rate of fire and a distinctive flash discharge. Its muzzle velocity is approximately 265 ft./sec. The maximum range is 700 yd., but the rocket is comparatively inaccurate at ranges over 300 yd. In the hands of trained personnel, it is a powerful supporting weapon at short ranges with limited fields of fire. It is highly effective against all known types of medium tanks.

b. Tactical use.— (1) Offensive action.— Being both highly mobile and effective against pill-box and mechanized defenses, the antitank rocket, 2.36", M6A1, is a valuable weapon to be carried by landing forces, raiding groups, tank-hunting parties, and motorized reconnaissance units. It is capable of delivering harassing fire against an area target from ranges as great as 600 yd. and so is extremely valuable in attacks on vehicular bivouacs and halted or disabled armored vehicles and for use in ambushes.

(2) Defensive action.— The foremost use of this weapon is that of a defensive weapon against the attack of mechanized forces. It should always be conserved for this emergency purpose. Whenever time permits, rocket teams will be assigned a definite place in the antimechanized defense of a weapon, unit, or installation; and if natural cover is not available, two-man-type fox holes will be dug for each rocket team. In the event of a surprise

attack, rocketeers must maneuver themselves in the most favorable position to direct their fire against the nearest hostile vehicle. The antitank rocket is valuable in the following defensive situations: the close-in defense of crew-served weapons; the protection of motorized columns on the march and at temporary halts; the protection of minefields, wire entanglements, observation and command posts; and the defense of all rear-area installations of all arms and services within the range of hostile mechanized forces.

(3) Miscellaneous.— In addition to the above uses as an antitank projectile, this rocket can also be used in a stationary emplacement for demolition or as an antitank mine or a booby trap.

c. Effect.— (1) The rocket will penetrate 3" of homogeneous-steel armor plate at all ranges and at angles of impact as low as 30°. The force of the detonation is so great that the metal of the armor plate is raised to a state of incandescence and heated particles of the metal fly from the back of the plate in a cone-shaped spray. This spray has antipersonnel effect as far as 30 yd. and usually causes any ammunition which it strikes to detonate.

(2) Against masonry and structural steel, the rocket has a powerful blast and shattering effect. It will penetrate up to 9" of pine timber, but its continuing spray is not as effective as in the penetration of armor plate. Ground impact will not ordinarily cause detonation at high angles of impact. At low angles of impact, the blast effect is similar to that of the 75-mm high-explosive shell. Impact against water will never cause detonation.

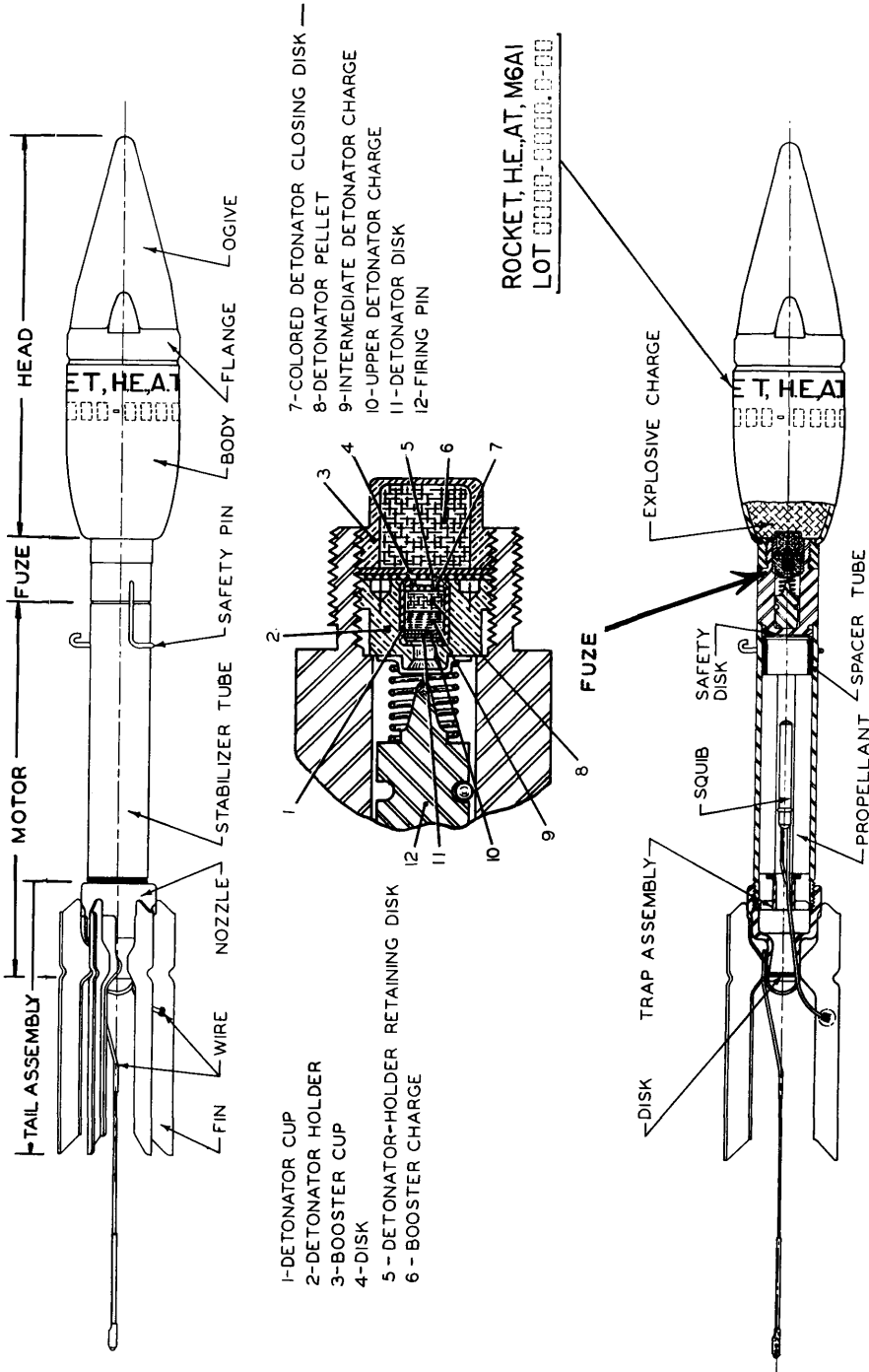

FIGURE 6. - ROCKET, H.E., AT, 2.36", M6A1

## 11 ROCKET LAUNCHER, M1A1

a. General.— The 2.36" antitank rocket launcher, M1A1, is an electrically operated weapon of the open-tube type. It is fired from the shoulder in the standing, kneeling, sitting, or prone positions. The tube has a smooth bore and is approximately 54.5" long. It is 2.37" in internal diameter and weighs 13.26 lb.

b. Description.— (1) Attached to the left side of the barrel are the front and rear sights. The rear sight is a peep sight; the front sight consists of three studs for ranges of 100, 200, and 300 yd. Intermediate or greater ranges, lead, and windage must be estimated by the firer.

(2) Ahead of the front sight and secured to the tube by a screw and nut is a flash deflector of conical wire screen with a mounting clamp which overlaps the muzzle end of the launcher. The flash deflector deflects particles of unburned powder which might fly back in the face of the firer.

(3) The hand grip consists of the left and right trigger grips attached to the trigger support. The trigger support accommodates the trigger guard, trigger, and the lower and upper trigger-switch contacts. The trigger is pinned at its upper end to the trigger support and is free to pivot.

(4) The stock has a narrow vertical slot by means of which it slips over the stock support, to which it is attached by screws. In the bottom of the stock there are two vertical cylindrical compartments for accommodating four batteries. The two batteries in the rear compartment are in actual use; the two batteries in the front compartment are spares. Eveready 791-A batteries are issued initially. When replacement is necessary, two separate cells of the battery BA-42 type can be used if the Eveready batteries are not available. The batteries are kept in position by a hasp assembly which fits on the bottom of the stock and is kept closed by a spring-actuated hasp catch which engages the stock pin.

(5) On the left side of the stock is a small electric lamp for testing the electric circuit and battery. The lamp is connected parallel with the firing mechanism, and it lights when the trigger is squeezed, regardless of whether the rocket is in the launcher or not. A spare lamp is carried in a circular compartment on the right side of the stock, under the circuit indicator cover.

(6) The face guard, pressed on the barrel above the stock and held in position by its own tension, protects the firer's face from the heat in the tube.

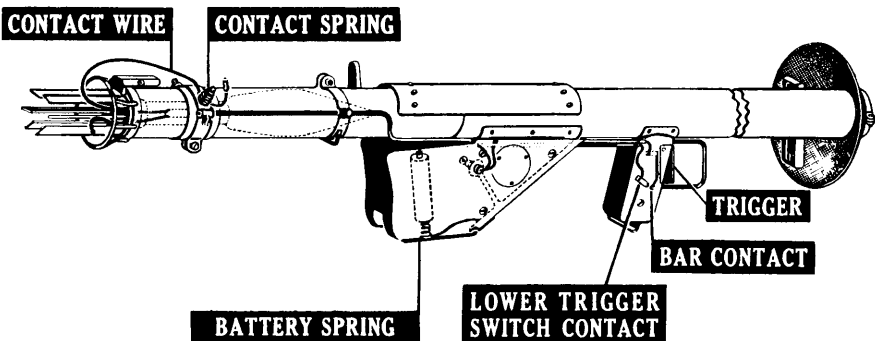

FIGURE 7. - ROCKET LAUNCHER, M1A1

(7) At the rear of the barrel is a spring-actuated tail-latch assembly. The function of the latch is to engage notches on the tail of the rocket and hold it in position for firing. The breech guard at the breech end of the barrel facilitates loading of the rocket, protects the tail-latch assembly, prevents distortion of the end of the barrel, and prevents entry of dirt and foreign material when the end of the launcher rests on the ground.

c. Electrical functioning (see fig. 7).— (1) When the trigger is squeezed, it presses the bar contact against the lower trigger-switch contact to complete the electric circuit.

(2) The battery spring in the base of the stock contacts the batteries and is connected by wire to the stock support to complete the electric circuit. From the rear of the stock to the insulated contact springs, the barrel is wound with bracing wire. The two contact springs, one on each side of the tube, serve as connecting points for the contact wire leading from the rocket. In this manner, the circuit is completed. The electric current passes through the rocket and sets off an electric igniter which ignites the propelling charge.

(3) When the pressure on the trigger is released, the trigger spring forces the trigger to the forward position and the electric circuit is broken.

**12 ROCKET COMPONENTS**

The M6A1 rocket is 21.62" long and consists of a body and ogive assembly, complete with explosive components, and a stabilizer and fuze assembly, complete with explosive and propellant components. The total weight of the rocket is divided between these two component assemblies, the former weighing 1.57 lb., the latter, 1.82 lb. In the following paragraphs each component will be described. The explosive components will be discussed separately.

**13 BODY AND OGIVE ASSEMBLY**

This assembly (see fig. 6) comprises the head of the rocket. Taken by itself, it has the general appearance of a boattailed artillery projectile. It consists of a body, ogive, and body union.

a. Body.— This (see fig. 8) is a steel cup, 4.11" long, with a diameter of 2.23" at its forward open end and

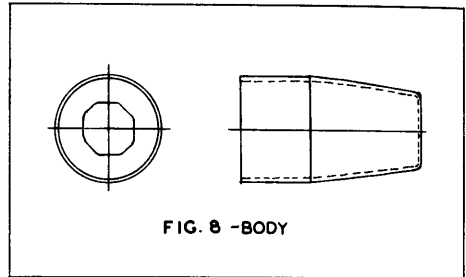

FIG. 8 -BODY

with walls 0.087" thick. The rear half of the body is slightly tapered, and in the rear face is punched a hexagonal hole, 1.06" across the flats. Into this hole is fitted the body union. An external longitudinal groove, 0.175" wide and 0.037" deep, is pressed 0.385" to the rear of the forward end of the body.

b. Ogive.— The ogive (see fig. 9) is a cone, 4-1/2" in height and 2.245" in diameter. The walls of the cone are 0.031" thick and are bulged out to form a flange approximately 1/2" wide at the base. This flange fits over the open end of the body and acts as the forward bearing surface of the rocket in its travel through the launcher. The flange is clinched securely into

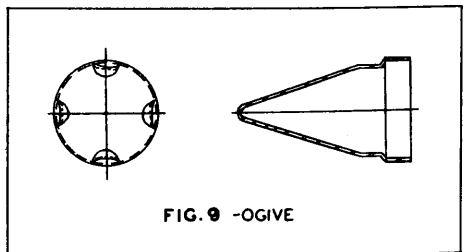

FIG. 9 -OGIVE

the groove in the forward outer surface of the body. Four depressions

are formed in the ogive just above the flange. These depressions rest on the upper rim of the body.

c. Body union.— The body union (see fig. 10) is a cylindrical component open at both ends. It is 0.78" in height and 1.25" in diameter. At the forward end, the body union is reduced to 1.058" in external diameter for a distance of 0.25" and is tapered internally. This allows the union to fit into the hexagonal hole in the rear of the body, where,

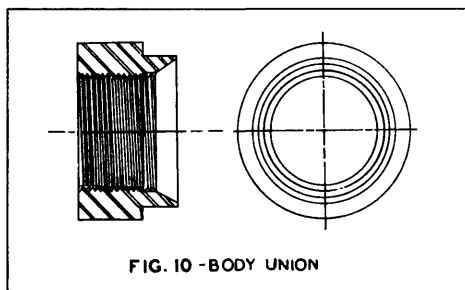

FIG. 10 - BODY UNION

after insertion, it is crimped into place. The central hole of the union is threaded to seat the stabilizer-tube assembly.

#### 14 STABILIZER ASSEMBLY

a. Functions.— The stabilizer assembly has the following functions:

(1) To house the fuze and propellant. This part of the rocket is called the "motor," i.e., the part that does the propelling.

(2) To house the electric firing attachment.

(3) To serve as an escape vent for the propellant gases.

(4) To stabilize the rocket in its flight.

b. Components.— The stabilizer assembly consists of the stabilizer-tube assembly, fin assembly, electric wiring and connections, and trap assembly. The components are described in the following subparagraphs.

(1) Stabilizer-tube assembly. This component (see fig. 6) consists of a stabilizer tube, a fuze body, a safety pin, and a fuze.

(a) Stabilizer tube.— This component (see fig. 6) is made of steel tubing 6.322" long and 1.060" in internal diameter with walls 0.095" thick. The forward rim of the tube is chamfered; the rear 0.44" of the tube is externally threaded.

(b) Fuze body.— This component (see fig. 11) is a thick-walled cup, cut away on its forward part to form a

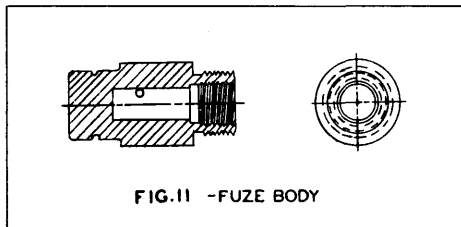

FIG. 11 - FUZE BODY

threaded projection 0.93" in diameter. The center section of the body is 1.25" in diameter; the rear section is 1.061" in diameter to allow a forced-fit joint in the forward end of the stabilizer tube. The over-all length is 2.317", and the central hole is 1.772" deep and 0.500" in diameter. At the point where the forward projection begins, the central hole widens to a diameter of 0.68". From this point forward, the central hole is internally threaded to seat fuze components. A hole 0.089" in diameter is drilled transversely through the fuze body just above the long axis of the body that intersects the central fuze body hole.

(c) Safety pin.— This component is inserted in the transverse hole mentioned in (b), above, where it restrains the firing pin of the fuze. Upon removal of the pin, the fuze is armed. When the safety pin is removed, DO NOT DROP THE ROCKET.

(d) Fuze.— 1 The fuze (see fig. 6) consists of a steel firing pin and a firing-pin spring. The firing pin is roughly cylindrical in shape and has a point 0.31" long protruding from the flat forward face. The firing pin slips into the central cavity of the fuze body, where it is held in a rearward position

## M6A1 ROCKET

by the firing-pin spring. A circumferential groove, 0.045" deep, midway down the length of the firing pin, receives the safety pin when the latter is in place. The safety pin, when in this groove, holds the firing pin securely in a rearward position. When the safety pin is removed, the firing pin is free to move forward, restrained only by the action of the firing-pin spring. Dropping the rocket as little as 4' will provide sufficient impact for the firing pin to overcome the tension of the spring and cause the rocket to be detonated. Therefore, when the safety pin is removed, it is necessary to take every precaution not to drop the rocket.

2 Below and in line with the firing pin and spring is the M18 detonator assembly and the explosive charge. The detonator assembly consists of an aluminum detonator cup, 0.342" deep, 0.190" in diameter, and crimped at both ends. It is housed in a brass detonator holder that screws into the internally threaded opening of the fuze body. A brass booster cup, 0.480" deep, 0.530" in diameter, and externally threaded on the rim, is screwed into place in the fuze body after the detonator holder is fitted. The booster cup and the detonator holder are separated by an onionskin disk and a detonator-holder retaining disk. The second disk is made of aluminum and seals, in turn, the detonator holder in place in the fuze body. The lower or unthreaded external half of the booster cup extends beyond the fuze body, and, when the stabilizer assembly is screwed into the rocket body, the booster cup fits into a recess in the explosive charge.

(2) Fin assembly.— The fin assembly, which guides the rocket in flight, (see fig. 12) consists of six steel fins and the nozzle. Each fin is attached to the nozzle by two spot welds on the lower flange.

(a) The fins are made of sheet steel 0.041" thick and 5-1/2" long. The fins are flanged at top and bottom in the

shape shown in figure 12. In the upper edge of each fin is cut a notch 1-2/3"

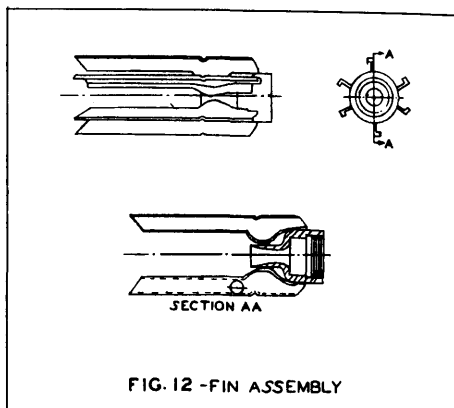

from the leading edge. This notch is kept free of paint and is tinned with solder. On the side surface of each fin, an area 1/8" in diameter is treated similarly. All external surfaces of the fin assembly except the tinned surfaces of the fins, which are kept free as electric contacts, are coated with olive-drab lacquer enamel.

(b) The nozzle is a steel cup internally threaded at the forward end. The rear face of the cup narrows and continues to the rear, forming the nozzle proper. The internal surface of the rear half of the nozzle is curved smoothly, as illustrated in figure 13, and is given a fine finish. The forward

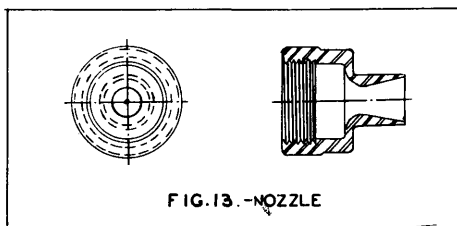

half of the nozzle is 1.49" in diameter; the rear half is 0.687" in diameter. Internal surfaces of the nozzle are coated with a light coat of priming paint.

(3) Electric wiring and attachments.— This component ignites the propellant and is an electric squib with two insulated lead wires of unequal



length. The squib is thrust up into the stabilizer tube so that its forward end is approximately 5-1/2" forward of the rear end of the nozzle. Both lead wires, one 18-3/4" long, the other 6-3/4" long, extend rearward out of the nozzle. The short length is stripped sufficiently at its free end to allow it to be soldered to a tinned spot on one of the fins. The longer length of wire is wrapped twice about the under projection of one of the fins. The last 6-1/2" of the wire are laid bare, and a 1/2" length is folded back twice upon itself. Over this node of wire is wrapped a 6" length of 1/2" black tape. This taping facilitates grasping the end of the wire. The wire is then spiraled to take up its slack, and the free end is reversed and taped lightly (with cellulose tape) to the rear end of a fin (see fig. 6). When the rocket is loaded into the launcher, the wire is torn from the tape and its bared length engaged in the launcher clips.

(4) Trap assembly.— The trap assembly, which holds the propellant in the best burning position, consists of a steel trap body and a trap ring, shaped as illustrated in figure 14, the trap ring being staked to the trap body. The assembly is either cadmium or zinc plated.

(a) The trap body is made of steel and has eight equally spaced ribs.

(b) The trap ring is made of steel.

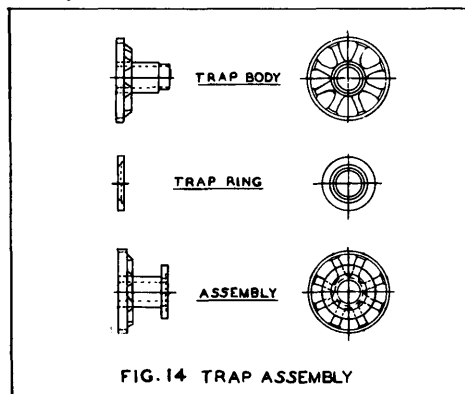

FIG. 14 TRAP ASSEMBLY

c. Assembly.— The fuze body is inserted in the forward end of the stabilizer tube and is held in place by the tight fit required. A silver-solder ring is slipped down the tube and, upon heating, melts and seals the internal joint between fuze body and tube. Following this, a dome-shaped disk is slipped down the tube, convex side up, and pressed flat against the fuze body. The disk is a safety factor; it removes the possibility of propellant flames or gases working through or around the fuze body to cause premature functioning of the rocket. The firing pin is inserted and the safety pin run through the transverse hole and the firing-pin groove. The detonator holder, with detonator, is screwed into the fuze body, followed by disks and the booster cup. The propellant is inserted in the tube. The trap assembly is screwed into the large opening of the nozzle, where it rests on the rim just below the internal threads. Then the fin assembly is screwed onto the rear threads of the stabilizer tube. Pettman cement is applied to the threads of the nozzle to waterproof the thread mesh. The rear end of the nozzle is closed with a chipboard disk, which is notched to provide for the passage of the lead wires.

## 15 EXPLOSIVE COMPONENTS

a. Propellant.— The propellant consists of five sticks of ballistite, each 0.36" in diameter and 4.15" long. The rocket is not loaded by weight but by length of powder stick — the purpose being to keep the pressure for various rounds at a relatively constant value. On the average, however, the propellant weighs approximately 61-1/2 grams. The propellant and its components are loaded as follows: A spacer tube, made of kraft paper, 1" in diameter and 3/4" long, is slipped into the stabilizer tube, coming to rest against the flattened disk. The five propellant sticks are slipped into the tube, coming to rest upon the rim of the spacer. When the

**M6A1  
ROCKET**

nozzle is screwed onto the stabilizer tube, the propellant sticks rest on the rim of the trap ring and are held securely in place.

b. Other explosive components.— The body contains the explosive charge, and in the fuze body are the M18 detonator and the booster. The detonator consists of an upper detonator charge of 0.98 grains of lead azide and a detonator pellet of 1.26 grains of tetryl. The booster charge is a pellet of tetryl weighing 1.86 grains.

**16 PAINTING AND MARKING**

a. Painting.— All external surfaces of the complete rocket are coated with olive-drab ammunition paint. Those surfaces previously mentioned as being unpainted remain so.

b. Marking.— Just below the joint of ogive and body, the name of the round, the lot number, the manufacturer's initials, and the month and year of loading are marked circumferentially with yellow marking ink. All the letters and figures are 3/8" high. Sample marking:

ROCKET, H.E., A.T., M6A1

Lot 1234-56, P.A. 9-43

**17 PACKING**

The M6A1 rocket is packed one per individual fiber container, M87 (see fig. 15). Twenty such loaded containers are packed in a wooden packing box. The box, complete with contents, weighs approximately 136 lb. and is equipped with two rope handles to facilitate its handling.

a. Container, M87.— This container follows the standard design for fiber containers, consisting of a cylindrical tube and cover of laminated asphalt-filled chipboard. The container is 22-1/2" long and 2-3/4" in diameter. The tube and cover are each closed at one end with a terneplate end plate. A plywood support ring rests on a chipboard spacer at the lower end of the tube. It prevents the nose of the rocket from touching the end plate.

After the round is inserted in the container, the cover is sealed in place by means of a strip of 2" adhesive tape 20-1/2" long. This strip is olive drab in color and has the designation of the rocket (Rocket, H.E., A.T., 2.36", M6A1) marked on it in yellow figures and letters.

b. Packing box.— (1) The packing box (see fig. 15) is 18-2/3" x 13-1/2" x 24-1/2" and is sturdily constructed of 3/4" lumber reinforced by end and top cleats. Two 16" lengths of manila rope are securely attached to opposite sides of the box and serve as carrying handles. The box is stained a light brown, and all the exposed metal parts are painted with light-brown lusterless enamel. The box has identifying marking (see fig. 15) in black paint.

(2) The 20 loaded containers are inserted in the compartments (formed in the box by fiberboard dividers) so that adjacent containers are tail end up and nose end up, respectively.

**18 SAFETY PRECAUTIONS**

a. The safety pin should be removed only after the nose of the rocket is placed in the launcher.

b. The rocket is sensitive and will function if dropped on its nose upon a hard surface from a height of 4'. Do not remove the safety pin except as explained above. Even when still in the packing containers the rockets must not be subjected to rough handling.

c. Rockets which have been unpacked but not fired should be returned to their original packing containers. The safety pin and the nozzle disk must be in place. The fiber container should be resealed with the adhesive tape.

d. Rockets should be stored in a dry, cool place. They should not be stored where temperatures exceed 120° F., and they should not be exposed to the direct rays of the sun.

e. Face guard and gloves must be worn when the rocket is fired.

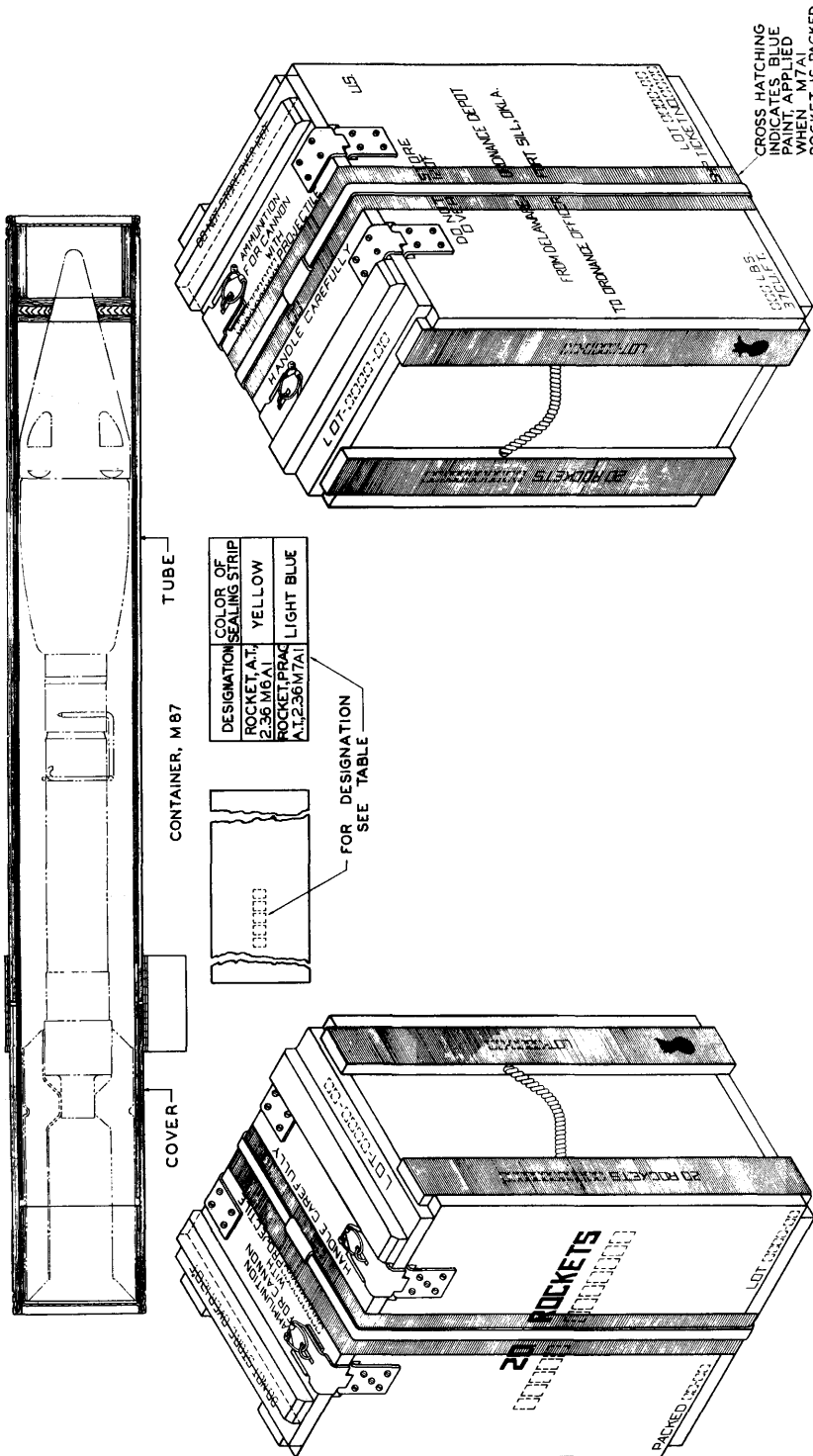

FIGURE 15. - PACKING FOR THE ROCKET, H.E., AT, 2.36", M6A1

SECTION II

ROCKET, PRACTICE, 2.36", M7A1

19 GENERAL

The M7A1 rocket (see fig. 15) is similar in design and construction to the M6A1 rocket, lacking only an explosive charge. It has the same dimensions, weight, and trajectory as the H.E. rocket. It is fired in the same ranges as the M6A1 without the cost or danger incidental to firing the H.E. round.

a. Weight rod.— A steel rod, 5.33" long, 0.75" in diameter, and threaded at one end, is fitted into the fuze body. This rod makes up for the weight of the explosive charge and fuze present in the M6A1 rocket. All other components of the M7A1 practice round are similar to the components of the M6A1 rocket.

b. Use.— After it has been fired, the practice rocket, M7A1, may be used again as a dummy round in teaching methods of loading and handling.

c. Painting and marking.

(1) Painting.— All external surfaces of the M7A1 practice rocket, are coated with blue lacquer enamel. Fin surfaces serving as contact points for the igniter system are left unpainted and are tinned with solder.

(2) Marking.— In the same position as on the M6A1 H.E. rocket, the nomenclature of the round, the lot number, and month and year of manufacture appear in white marking ink.

d. Packing.— (1) The practice rocket is packed in the same manner and in the same container as the M6A1 rocket (see par. 17). The sealing strip for the container is light blue, and the appropriate nomenclature is stenciled in white.

(2) Twenty containers are packed into the wooden packing box in the same manner as the H.E. M6A1 round. The packing box is identical but is marked to correspond with the contents. In addition, a 3" blue band encircles the box when the contents are practice rockets. Blue paint is also applied to the vertical cleats at each end of the box.

e. Precautions.— The same precautions described in paragraph 18 must be exercised in the storage and handling of the practice rocket. However, since there is no bursting charge or firing mechanism, the removal of the safety pin does not arm the M7A1 rocket.

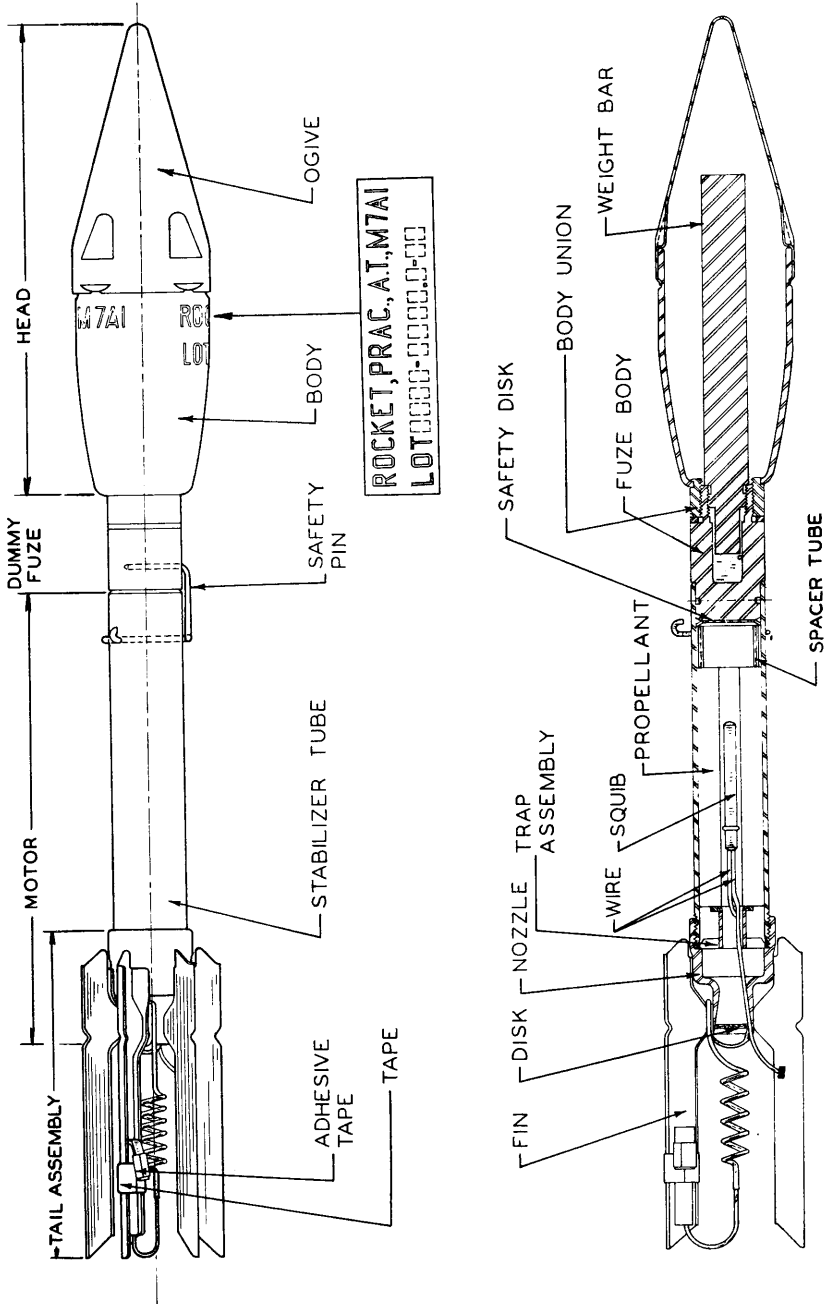

FIGURE 16. - ROCKET, PRACTICE, 2.36", M7A1

## SECTION III

## ROCKET, H.E., AT, 2.36", M6A3

**20 REASONS FOR CHANGE**

a. Change in ogive.— The design of the conical ogive of the M6A1 rocket proved to be undesirable for several reasons. First, the ogive tended to telescope on impact. This resulted in poor transmission of the impact force to the fuze, allowing a variation in the time interval between impact of the rocket and functioning of the fuze in successively fired rockets. Secondly, on impact at angles of  $20^\circ$  or more the conical ogive tended to shear off at the joint of ogive and body. This shearing had a serious effect on penetration of the target. The major difficulty with the conical ogive was that it failed to provide for a uniform, satisfactory penetration of the target by all rockets.

b. Change in tail assembly

With the contemplated addition of a hemispherical ogive it was realized that the center of pressure of the rocket would be moved forward and that the rocket would have a definite wobble through its trajectory unless the tail assembly were improved. For this reason it was decided to redesign the tail assembly. A circular assembly was the design finally accepted.

c. Redesignation of model number.— The North African theater has renovated the M6A1 and M7A1 rockets and assigned the model number M6A2 to the renovated rounds. Although the Ordnance Department did not officially recognize this designation, it was felt that the M6A2 designation should not be applied to any new ammunition because of possible confusion and misunderstanding. For this reason the designation M6A3 and M7A3 (see section IV) have been applied.

**21 HEMISPHERICAL OGIVE**

a. Description.— The ogive, made of sheet steel, has the shape illustrated in figure 17. It is  $4\text{-}9/16"$  long and  $2.245"$  in diameter at the flange. The hemisphere is curved on a  $1"$  radius.

b. Effectiveness.— With the hemispherical ogive, the fuze of the rocket has been found to function in an average of 875 microseconds compared to an average of 1250 microseconds in the M6A1 with a conical ogive. Penetration

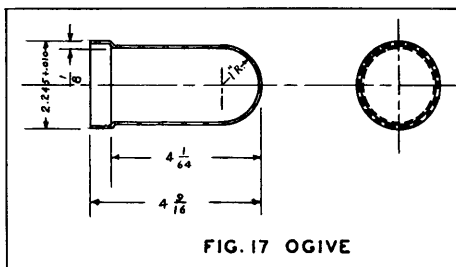

FIG. 17 OGIVE

has been uniformly improved. The improvements in functioning and penetration are due to the even transmission of impact force through the straight sides of the hemispherical ogive. On angle impacts, the M6A3 has resisted shearing and has maintained a fast fuze action and uniformly high penetration.

**22 TAIL ASSEMBLY**

a. Description of fin.— The new type of fin used on the M6A3 rocket has the shape illustrated in figure 18. Each of the four fins required in the complete assembly is made of  $.025"$  sheet steel. The broad blade of the fin is  $2\text{-}5/16"$  long and curved over an arc of  $90^\circ$ .

b. Assembly.— Each fin is joined to the other by welding with an overlap

**DECLASSIFIED**

of approximately 1/2". The bases of the fins are spot welded to the nozzle. Through the upright section of one of the four fins is a small hole. This hole is for insertion of one of the ignition wires. In the blade of each fin is a transverse groove which is continuous with the grooves in the other three fins in the complete assembly. This groove is tinned and serves as a contact point with the electrical system of the launcher.

c. Effectiveness.— The M6A3 rocket with the circular fin has slightly better ballistic qualities than the M6A1 rocket had with the old-style tail assembly. Considering that the center of pressure has been moved forward, this is a marked improvement.

**23 OTHER CHANGES**

There are no other changes in the M6A3 rocket. In all other respects it is similar to the M6A1 rocket.

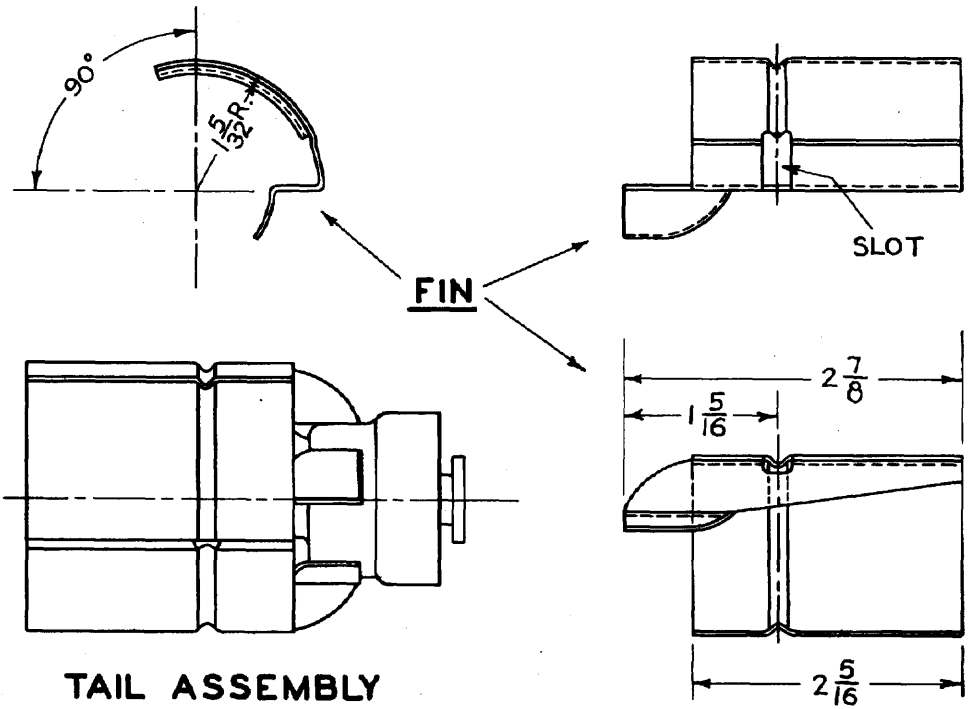

**FIG.-18 TAIL ASSEMBLY**  
**SECTION IV**

**ROCKET, PRACTICE, 2.36', M7A3**

**24 CHANGES**

The M7A3 rocket has all the changes mentioned above in the M6A3

rocket. It is the practice counterpart of the M6A3 and has the same ballistic qualities.

**DECLASSIFIED**

**M6A3  
ROCKET**

**DECLASSIFIED**

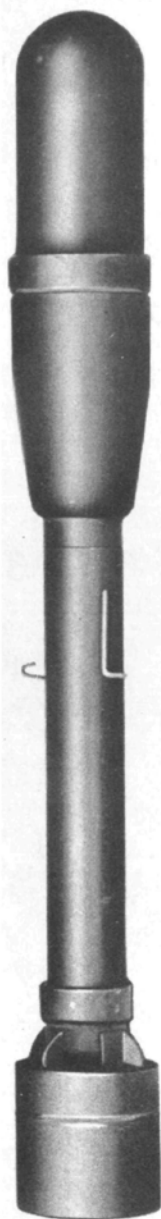

**DECLASSIFIED**



**M6A3  
ROCKET**

**DECLASSIFIED**



**DECLASSIFIED**

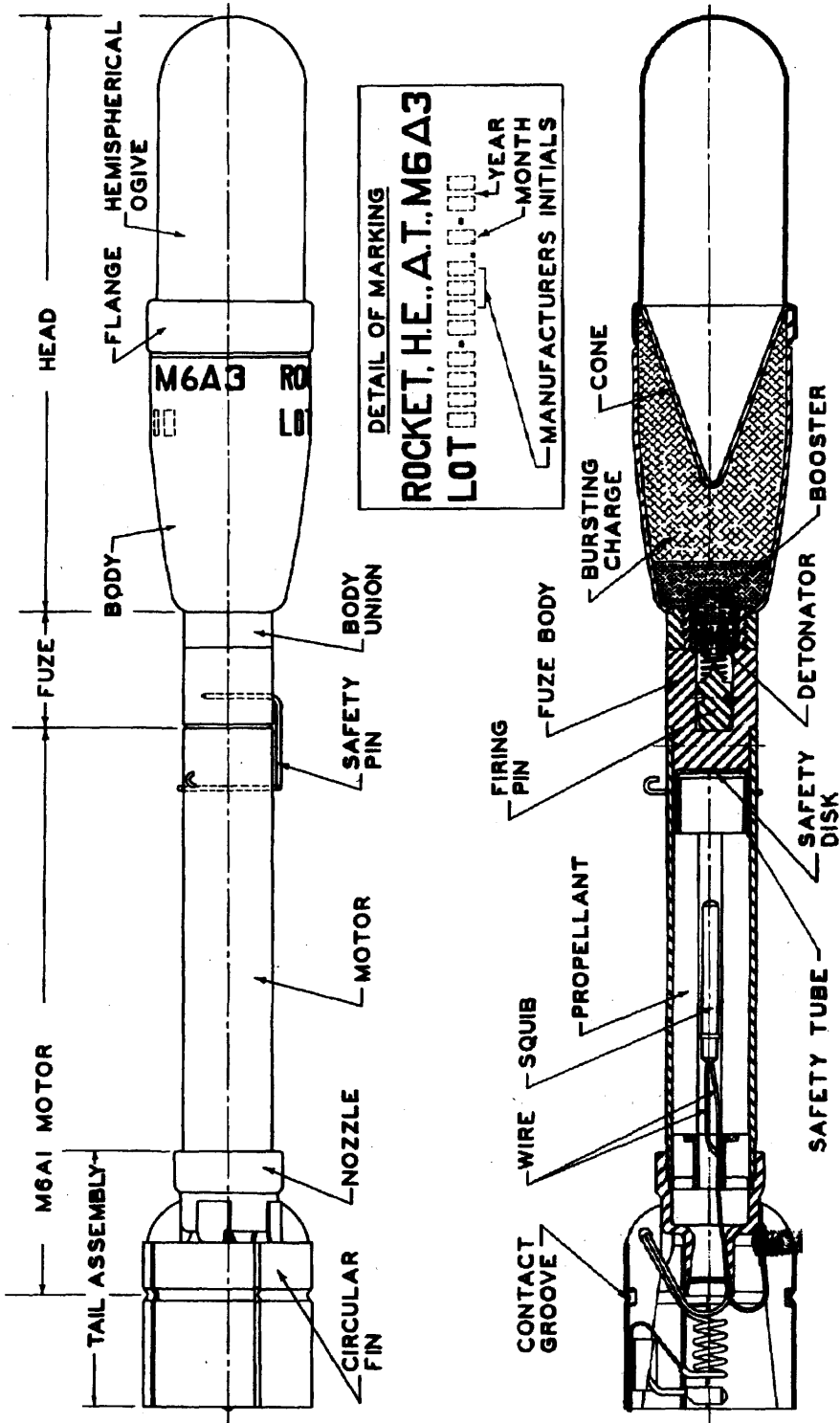

FIGURE 19. - ROCKET, H.E., AT, 2.36", M6A3

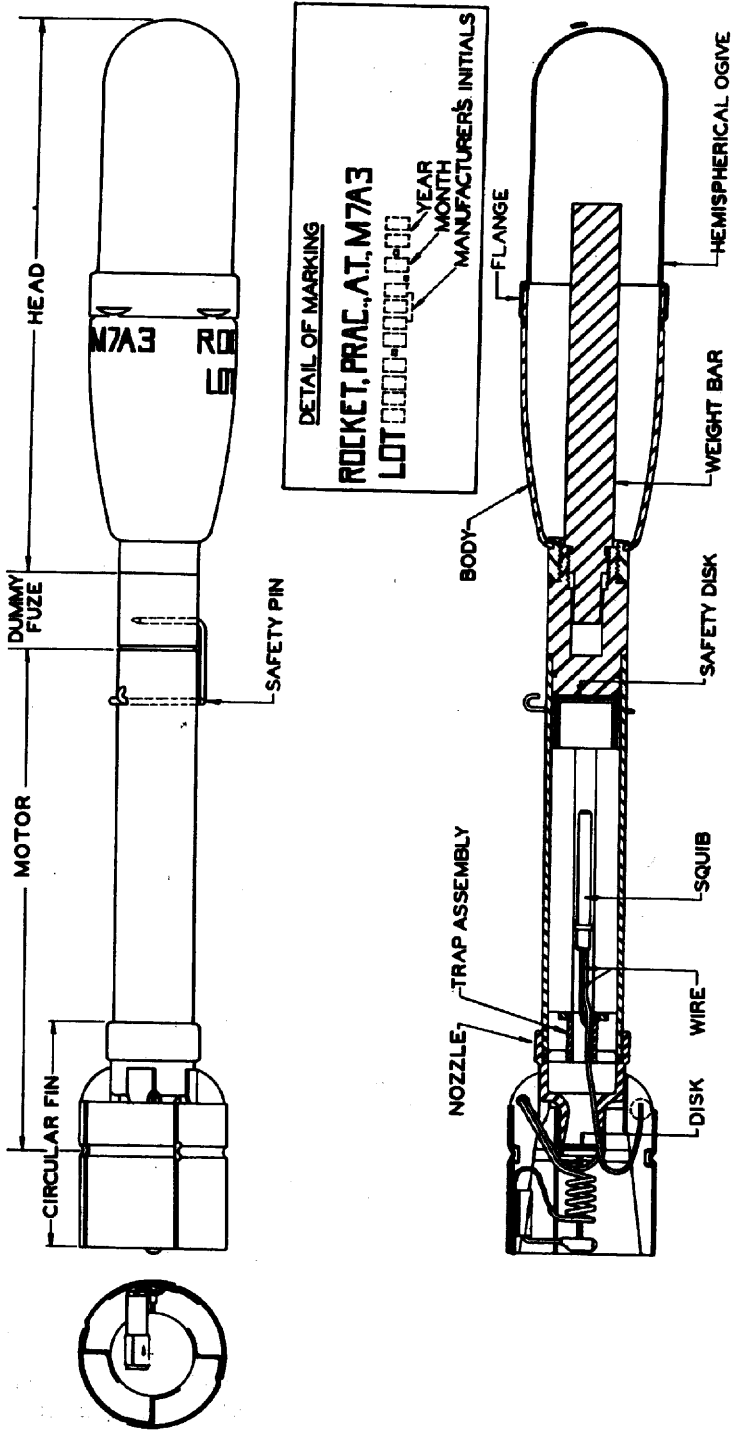

FIGURE 20. - ROCKET, PRACTICE, 2.96", M7A3

**DECLASSIFIED**

**M7A3  
ROCKET**



**DECLASSIFIED**

DECLASSIFIED

M7A3  
ROCKET

T12  
ROCKET

DECLASSIFIED

SECTION V

ROCKET, H.E., AT, 2.36', T12

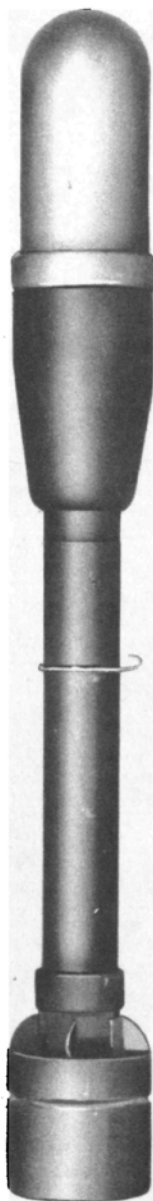

25 REASON FOR DEVELOPMENT

The M6A1 rocket has been used widely in combat, and its deficiencies have been noted. The development work on the T12 was started so that all the deficiencies of the earlier rockets might be corrected. The T12 rocket retains all the good qualities of the M6A3. Specifically, the new performance characteristics are:

- a. Greater stability in flight and a consequent greater accuracy.
- b. Safe operation through a greater temperature range.
- c. A bore-safe fuze — the most important change in the T12.
- d. Detonation of the rocket on ground impact for use against personnel. This involves the employment of a more sensitive fuze.

26 GENERAL

- a. Appearance.— See figure 21.
- b. General data.—

Length, over-all -----	17.16" max.
Length of head -----	8-1/4"
Length of motor -----	7.5"
Length of fin -----	3-15/16"
Explosive charge -----	220 gm.
50-50 cast pentolite -----	214 gm.
10-90 cast pentolite -----	6 gm.
Propellant (approx.) -----	63 gm.
Weight of complete rocket ---	3.72 lb.

c. Components.— The M6A3 head and the T12 head are identical. Several other components, including the fuze, are new. The fuze will be discussed in a separate paragraph; the components of the new motor and fin assembly will be discussed in the following subparagraphs.

(1) Motor assembly.— (a) Tail.  
The tail is a seamless steel tube 7.50" long and approximately 1.330" in diameter. The rear end of the tube is curved in a venturi. The throat at its narrowest point is .433" in diameter. The central internal portion of the tail is approximately 1.06" in diameter. The forward internal .75" of the tail is threaded. The outer rear surface of the tail seats the tail assembly.

(b) Rein ring.— This circular steel band is shrunk onto the tail at the threaded forward end. It strengthens this end of the tail.

(c) Trap and trap-base assembly.— The trap and trap-base assembly consists of the trap and trap base. The trap is a star-shaped device made of steel. The central portion has a .125" hole, and from it radiate five spokes, 72° apart and .51" long. The trap is fitted onto the trap base. The trap base is a disk 1.0" in diameter and .08" thick. A spindle 21/32" high and .271" in diameter projects from the center of one face. The last 7/32" of the spindle is reduced in diameter to .123". Onto this section of the spindle is fitted the trap. The end is peened to hold the trap in place. The complete trap and trap-base assembly is soldered to the surface of the fuze body. The propellant hangs on the trap and is thus rigidly held in the motor.

(d) Igniter.— No information on this item is available at present.

(e) Propellant.— The propellant in the T12 motor is the same as that used in the M6A3. It consists of five sticks of ballistite, each approximately 4.15" long and .375" in over-all di-

DECLASSIFIED

DECLASSIFIED

DECLASSIFIED

T12  
ROCKET

T12  
ROCKET

DECLASSIFIED

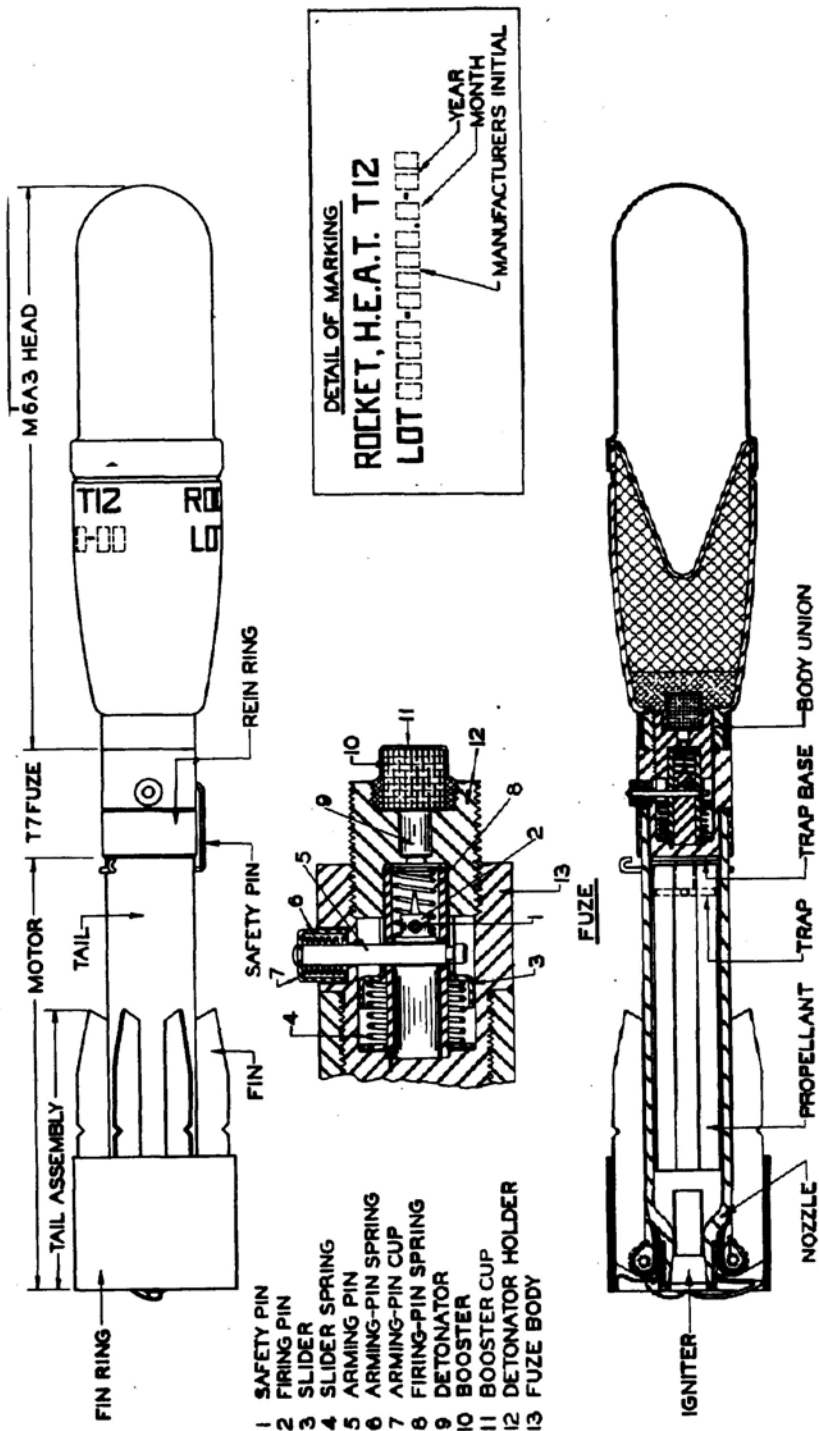
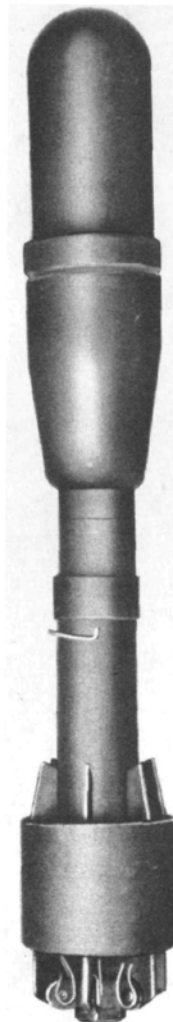

FIGURE 21. - ROCKET, H.E., AT, 2.36", T12



DECLASSIFIED

DECLASSIFIED

DECLASSIFIED

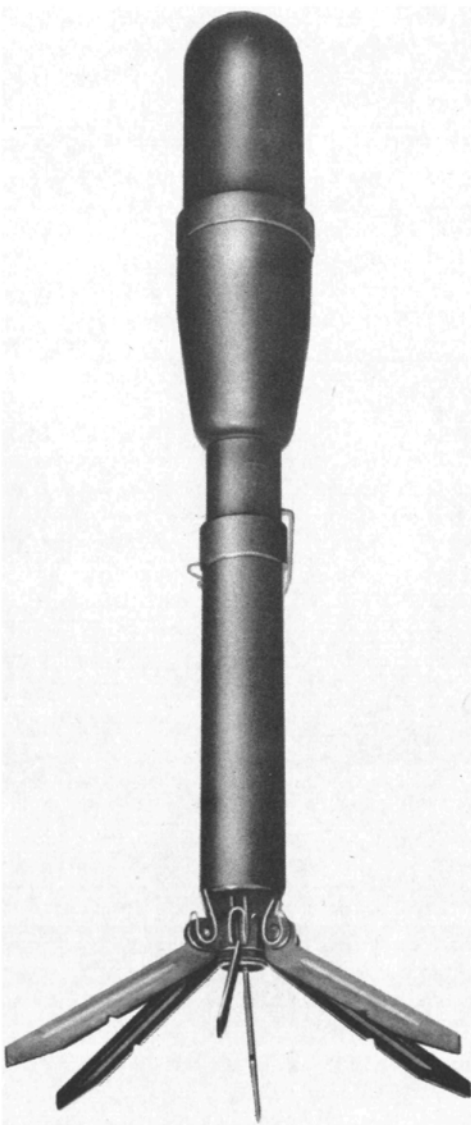

██████████  
DECLASSIFIED

DECLASSIFIED

ameter. Through each stick runs an axial hole .125" in diameter. The rocket is not loaded by weight, as is explained in paragraph 15, but it weighs approximately 63 gm.

(2) Fin assembly.— This assembly consists of six fins, six fin brackets (one of which is slightly different from the other five), rivets, and a fin ring. The six brackets are spot welded onto the tail surface of the motor. The fins are held in place between the brackets by rivets passing through the holes in the brackets and the fin hole. The fin is free to rotate 120° and is checked from further movement by a slanted surface on the back of the fin. The fins are held in place along the motor by a fin ring. This ring is a circular band and is removed when the rocket is placed in the launcher.

#### 27 FUZE, ROCKET, 2.36", T7

a. General.— The T7 fuze was developed to meet the need for a safer, faster functioning fuze. (See fig. 21.) Shortly to be standardized, it will be used in the T12 and the T23 rockets. The major difference between the T7 fuze and the fuze used in the M6A1 rocket is that the T7 is of the "bore-riding" pin type similar to the M52 mortar fuze. Because of this bore-riding feature, the T7 fuze is bore safe and yet suffers no reduction in effectiveness.

b. Action.— (1) The safety pin passing through the firing pin holds the latter securely in place. The slider spring presses forward against the shoulder of the slider. The slider, which is slotted on its forward rim, hooks into a groove in the inner end of the arming pin, holding the arming pin in position.

(2) When the safety pin is withdrawn, the firing pin is still held securely in place by the arming pin. Upon set-back, however, the slider is forced to the rear against the tension of the slider spring. This permits the arm-

ing pin, disengaged from the slider, to be forced out by the compression of the arming-pin spring until the arming-pin cup strikes the wall of the launcher.

(3) As long as the rocket remains in the launcher, the arming pin is held partly in the firing pin, holding the latter in position.

(4) When the rocket has cleared the launcher, the arming pin with its attached cup and the arming-pin spring are expelled. The firing pin is now free to move. The firing-pin spring is an "anti-creep" factor, preventing the firing pin from contacting the detonator except on impact.

(5) On impact, the firing pin, is driven into the detonator by inertia, exploding it. The detonation passes through the booster, where it is amplified, and the function of the fuze is complete.

#### c. Explosive components.

(1) Detonator, M18.— This is the same detonator as that assembled with the M6A3 rocket.

(2) Booster.— This is the same booster as that used with the M6A3 rocket.

d. Safety devices.— This fuze has several safety devices, most of which have been mentioned above. They are as follows:

(1) Safety pin.— This component holds the firing pin firmly in place and makes the fuze safe up to the shear point of the safety pin. This shear point will rarely be exceeded.

(2) Slider.— This component, under tension of the slider spring, holds the arming pin in place. The slider may be forced to the rear if sufficient acceleration could be simulated. Even in a free fall of 1' to 2' this acceleration would not be approximated and the slider would stay in its forward position.

DECLASSIFIED

(3) Arming pin.— This component makes the fuze bore safe, since it does not permit the firing pin to move forward until the rocket is clear of the launcher and the arming-pin assembly expelled.

(4) Firing-pin spring.— This spring prevents premature detonation of the rocket. Without the spring, the firing pin could move forward by creep action and set off the detonator.

## 28 BALLISTICS

a. Range.— The rocket has the same range as the M6A3, but its effective range has been slightly increased by the new fin assembly.

b. Penetration.— On angles of impact up to 30° the T12 rocket will penetrate the armor of any known enemy tank.

c. Effective fragmentation radius.— No information available.

d. Muzzle velocity.— No information available.

e. Launcher employed.— The M1A1 and M9 launchers are used to fire this rocket.

## 29 PAINTING AND MARKING

a. Painting.— All external surfaces of the rocket except the tinned notches of the fins are coated with olive-drab lacquer enamel.

b. Marking.— In two circumferential lines just below the flange on the rocket head is stenciled the following information:

ROCKET, H.E., AT, T12

LOT 0000-0000.00-00

All the figures and letters are 3/8" high and are applied with yellow marking ink. The lot number includes the

month and year of manufacture and the initials of the manufacturer.

## 30 PACKING

One T12 rocket is packed in a fiber container, T1. Twenty loaded containers are packed in a wooden packing box (see fig. 22).

a. Fiber container, T1.— This container is generally similar to all fiber containers. It is 18-3/8" long and 2-15/16" in diameter. The cover fits over the inner wall of the body and is held in place by a strip of yellow adhesive tape. The yellow sealing strip is 2" x 20-3/4" and is marked with 1/4" black characters as follows:

ROCKET, AT, 2.36", T12

The rocket is inserted in the container, ogive first, coming to rest on a ring-shaped plywood support in the bottom of the tube.

b. Packing box.— The packing box is generally similar to the packing box for the M6A1 rocket. The lid of the box is hinged on the side, and there is a single hinge and hasp. This box differs from the box for the M6A1 by the addition of stenciled Ammunition Identification Code designation. The volume of the new box has been reduced to 3.25 cu. ft.

### Packing-box data

No. of rounds contained -----	20
Volume -----	3.25 cu. ft.
Total weight -----	
Dimensions -- 20-1/8" x 19-1/8" x 14"	
No. of carrying handles -----	2

## 31 SAFETY PRECAUTIONS

All the safety precautions observed in handling the M6A1 rocket must be followed in handling the T12. In addition, the fuze of the T12 rocket is more sensitive to set-back, and a fall of 2' to 3' will cause the round to explode.



T12  
ROCKET

DECLASSIFIED

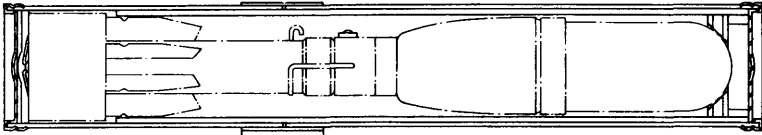

FIBER CONTAINER, T1

DESIGNATION	COLOR OF SEALING STRIP
ROCKET, A.T. 2.36, T12	YELLOW
ROCKET, PRACTICE A.T., 2.36, T23	LIGHT BLUE

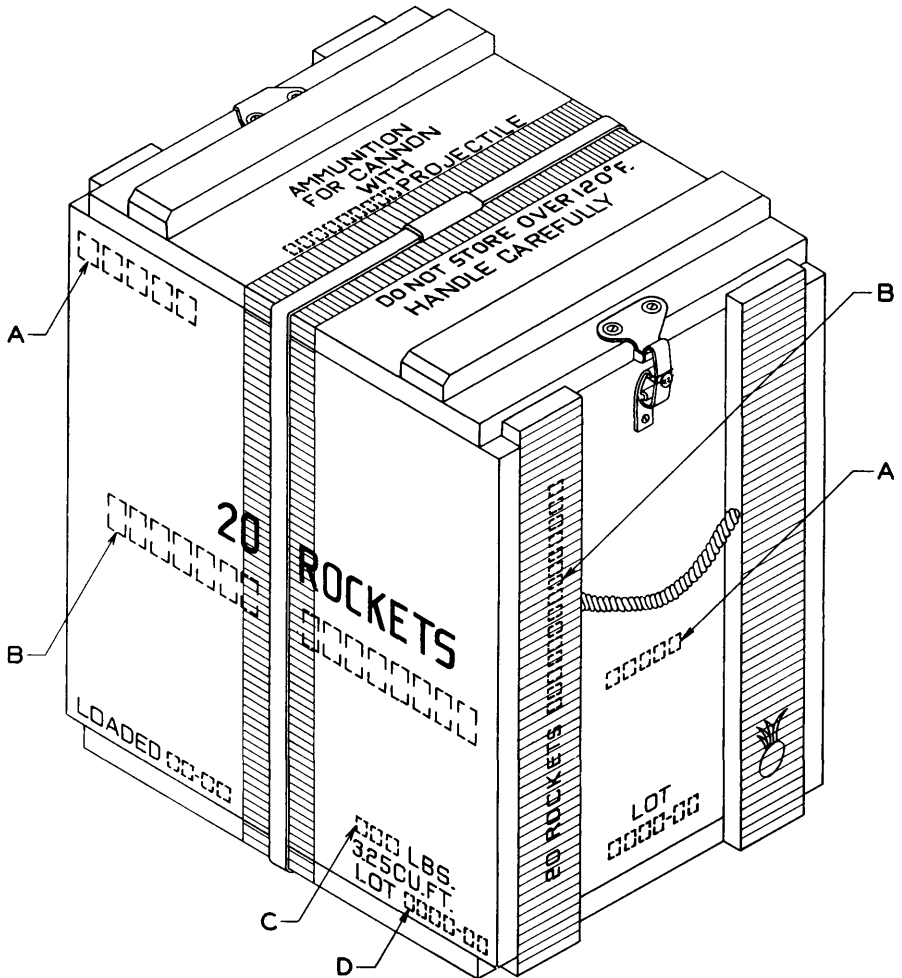

- A - INSERT A.I.C. CODE.
- B - INSERT "H.E., A.T., 2.36 IN., T12" OR "PRACTICE, A.T., 2.36 IN., T23" AS APPLICABLE.
- C - INSERT GROSS WEIGHT.
- D - INSERT LOT NUMBER.

FIGURE 22. - PACKING OF THE T12 AND T23 ROCKETS -

DECLASSIFIED

**DECLASSIFIED**

**NOTES**

**DECLASSIFIED**

NOTES

**DECLASSIFIED**

**DECLASSIFIED**

DECLASSIFIED

T23  
ROCKET

T23  
ROCKET

DECLASSIFIED

SECTION VI

ROCKET, PRACTICE, 2.36", T23

**32 REASON FOR DEVELOPMENT**

The T23 practice rocket was developed to provide an inert rocket having trajectory identical to that of the T12 H.E. AT rocket. The T23 is the practice counterpart of the T12 and may be used in training to simulate the action of the T12. The T23 practice rocket uses all the components of the T12 except a fuze and high-explosive head content. A weight bar is introduced that is equal to the weight of the fuze, and an inert composition fills the charge cavity. The T23 has the same type and weight of propellant as the T12 and is fired in the same manner and from the same launchers.

**33 GENERAL**

a. Appearance.— The rocket has the same general appearance as the T12 rocket. (See fig. 23.)

b. General data.— The practice rocket, T23, has the same weight and dimensions as the T12. (See par. 26b, section V.)

c. Components.— With the exception of the two components listed below, the T23 is identical to the T12.

(1) Weight rod.— This component is a steel cylinder 1.150" long and .495" in diameter. A transverse hole .089" in diameter is drilled through the rod .935" from one end. The two rims of the rod are slightly chamfered to insure a tight fit of the rod in the fuze body. The rod is positioned so that the transverse hole is in line with the holes in the fuze body, thus permitting easy insertion of the safety pin.

(2) Charge (inert).— Approximately .49 lb. of filler is poured into

the head, where it hardens. The filler is 60 percent plaster of paris and 40 percent zinc stearate. The cone of the T23 practice rocket causes the filler to adopt the same shape as the pentolite in the T12 rocket. In the M7A1 and M7A3 rockets the cone is not present.

**34 PAINTING AND MARKING**

a. Painting.— The T12 motor is used and is painted olive drab. The head of the T23 is coated with blue lacquer enamel.

b. Marking.— In two circumferential lines just below the body flange is stenciled the following:

ROCKET, PRAC., AT, T23

LOT 0000-0000.0-00

All letters and figures are 3/8" high and are stenciled with white marking ink.

**35 PACKING**

The T23 rocket is packed in much the same manner as the T12 (see fig. 22). There are obvious differences in nomenclature, and the adhesive sealing strip on the container is blue instead of yellow. A 3" blue band is painted around the packing box to identify the contents as practice ammunition.

**36 SAFETY PRECAUTIONS**

Safety precautions similar to those exercised with the T12 H.E. AT rocket must be enforced during handling of the T23 practice rocket. This will familiarize personnel with the proper handling of the T12 when they are called upon to handle and fire it.



DECLASSIFIED

DECLASSIFIED

DECLASSIFIED

T23  
ROCKET

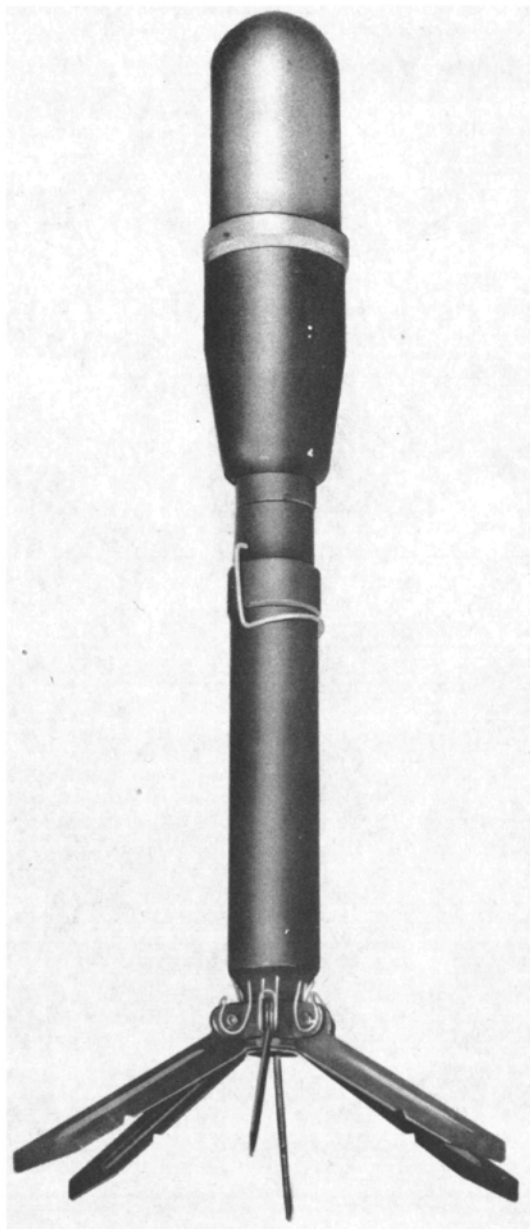

DECLASSIFIED

T23  
ROCKET

DECLASSIFIED

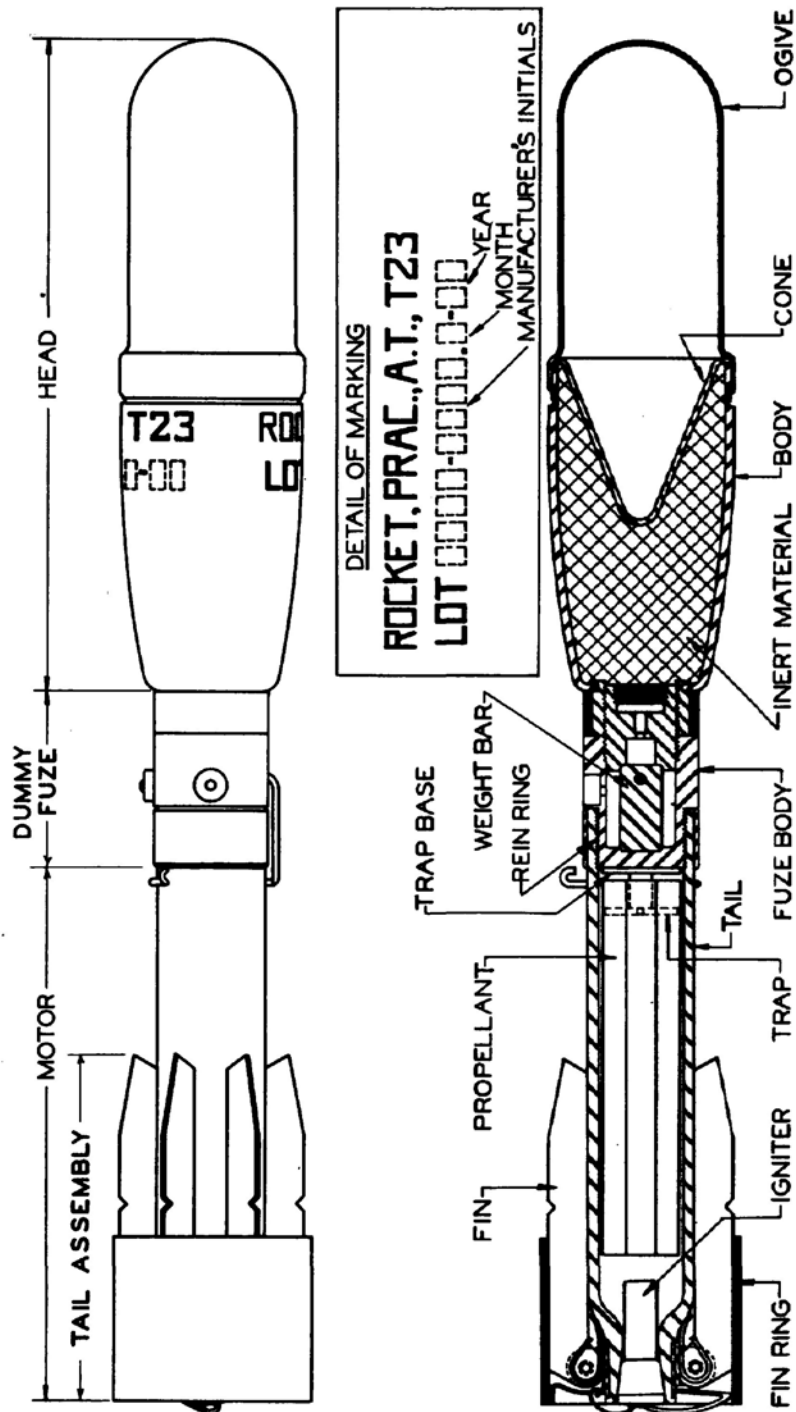

FIGURE 23. - ROCKET, PRACTICE, 2.36", T23

DECLASSIFIED

## SECTION VII

### ROCKET, SMOKE, WP, 2.36", T26

#### 37 REASON FOR DEVELOPMENT

a. Whenever possible, a complete series of rockets (high-explosive, practice, smoke, incendiary, and chemical) is developed. This is the policy of the Ordnance Department and holds for all calibers of rockets. In some cases the development of certain items of the series is impracticable or would serve notactical purpose. In any given caliber, all the rockets in the series must be designed with certain factors in mind. First, all the rockets must have the same trajectory. This is particularly true of the 2.36" rockets that are fired from the shoulder launcher. Secondly, in order to have similar trajectories they must have equal weight and, in the case of the higher velocity rockets, as nearly identical contours as possible. Thirdly, they must have as nearly interchangeable components as possible so that additional manufacturing facilities will not be required.

b. In line with this policy, the T26 WP rocket has been developed. Upon standardization this rocket will be assigned the model number M10.

#### 38 GENERAL

a. Appearance.— See figure 25.

b. Motor.— The T26 smoke rocket makes use of the motor currently standard for the 2.36" rocket. At the present time this is the motor assembled with the M6A1 rocket. The M6A1 motor is being replaced by the M6A3 motor, and the M6A3 motor will be replaced by the T12 motor when the T12 rocket is standardized and placed in production. This general statement concerning the use of the standard rocket motor for chemical rockets holds true for all 2.36" chemical rockets.

c. Use.— Tactical requirements call for a smoke with harassing quali-

ties. WP in smoke form has little effect upon the human body, but particles cause very severe burns. For the latter reason WP is an excellent smoke for use against enemy personnel both to blind them and to make them casualties.

#### d. General data.—

Length, over-all -----	19-5/16"
Length of head -----	5-1/2"
Diameter -----	2.36"
Diameter of head -----	2.30"
Weight of complete round -----	3.4 lb.
WP charge -----	405 gm.
Bursting charge -----	4 gm.

e. Components.— The components of the T26 chemical rocket are the motor assembly and the head assembly. The head assembly will be discussed in the following paragraph.

#### 39 HEAD ASSEMBLY

The head assembly consists of the container, the collar, the burster well, the bursting charge, the sealing cap, and the chemical charge. For the purpose of this description, the fuze body, the primer holder, and the primer will be considered as parts of the head assembly. They are actually modified components of the M6A1 motor assembly.

a. Container.— The container has the shape illustrated in figure 24.

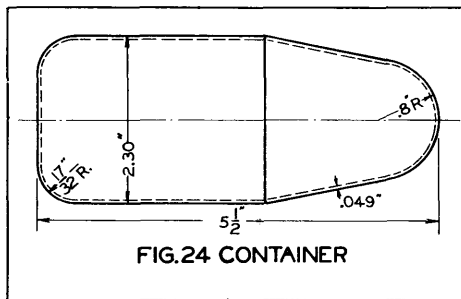

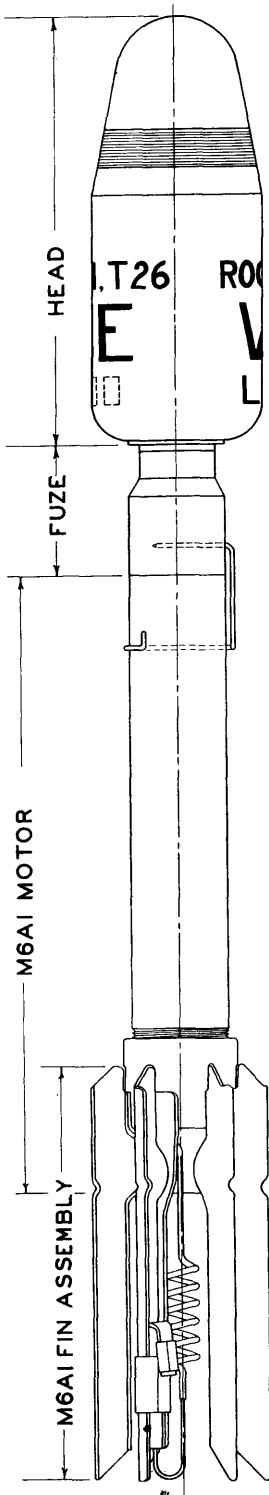

DETAIL OF MARKING  
 ROCKET, 2.36 INCH, T26  
**WP-SMOKE**  
 LOT 0000-0.0-00

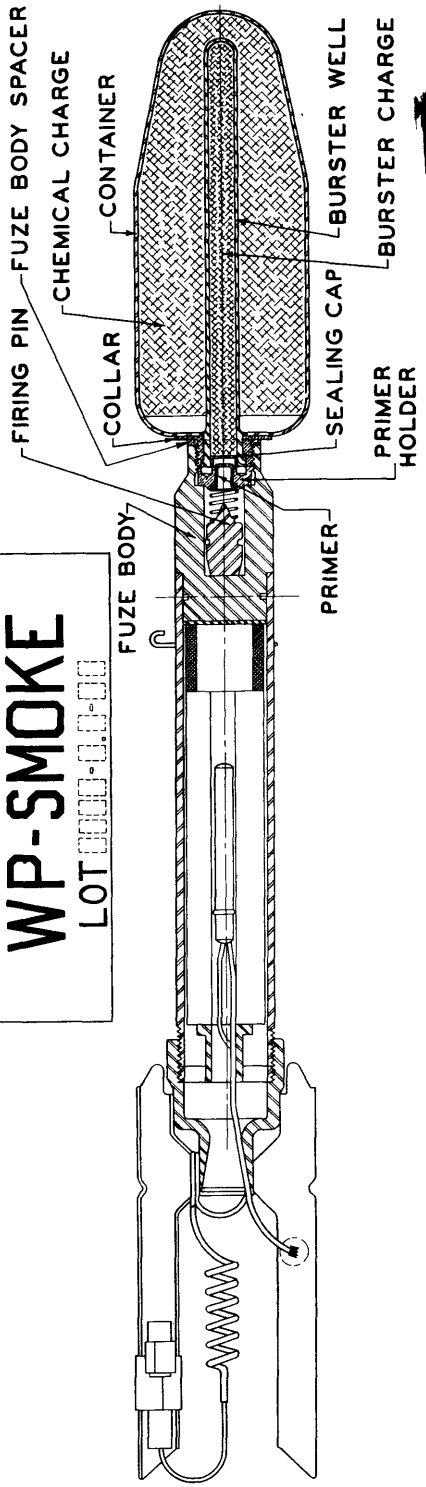

FIGURE 25. - ROCKET, SMOKE, WP, 2.36", T26

It is drawn from steel 0.49" thick and is curved at the forward end on a radius of .8". The rear end of the container, where curved, curves on a radius of 17/32". The center hole at the rear of the container is .937" in diameter.

b. Collar.— The collar is illustrated in figure 26. It is threaded as shown and is 1-1/4" in greatest diameter. It is made to seat in the central hole of the container. The collar

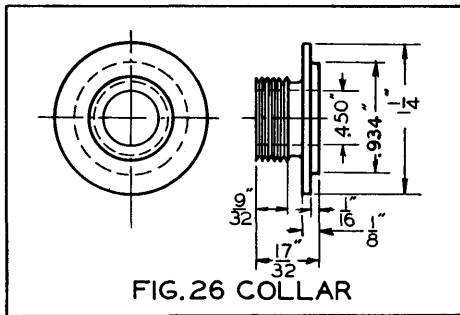

FIG. 26 COLLAR

is attached to the container by pouring silver solder through the joint. The fuze-body spacer slips over the threads of the collar and is held in place against the flat surfaces of the collar by the fuze body. It is a steel ring .938" in external diameter, .70" in internal diameter, and .119" thick. It seals the joint between the fuze body and the collar.

c. Burster well.— The burster well is a rimmed tube 5-5/8" long and .4" in diameter for the greater part of its length. The closed end of the tube is sealed airtight. The upper 1/2" of the tube is shouldered to a diameter of .547". The rim is .045" wide and has a total diameter of .562". The burster well extends through the collar into the container with its rim resting on the inner rim of the collar.

d. Bursting charge.— After the EC powder is poured into the burster well, the well is closed with a sealing cap.

e. Sealing cap.— The sealing cap is a kraft-paper cup .360" in di-

ameter and .125" deep. It is inserted in the well, open end up.

f. Chemical charge.— White phosphorus is poured hot into the container so that when the burster well is inserted there is a 1/2" dead space at bottom of the container.

g. Fuze body.— The fuze body assembled with the M6A1 motor used with the T26 smoke rocket has the shape illustrated in figure 27. It is a cylinder

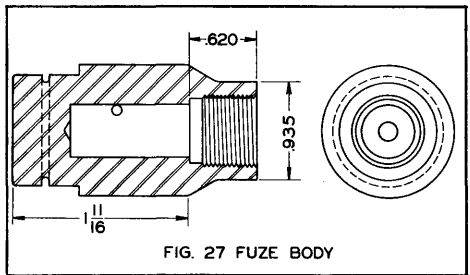

FIG. 27 FUZE BODY

approximately 2.307" long and 1.25" in diameter. The forward portion, which seats the collar, is .935" in diameter. Aside from the taper in the front end of the fuze body and its lack of external threads on this surface, it is similar to the fuze body of the M6A1 rocket.

h. Primer holder.— The primer holder has the shape shown in figure 28. It is screwed into the fuze body

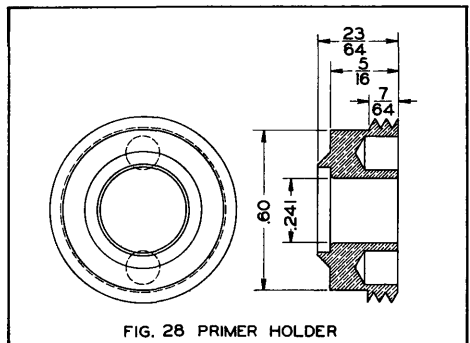

FIG. 28 PRIMER HOLDER

and holds the primer in position to receive the blow of the firing pin. It also acts as a firing-pin spring guide by holding the forward end of the firing-pin spring in place. The primer holder



is made of brass and is .60" in diameter. The central hole, the primer seat, is .24" in diameter. The holder is 5/16" thick and the firing-pin spring guide is approximately 3/64" above the adjacent surface. In the lower surface of the holder are two positioning holes for screwing the holder into the fuze body.

i. Primer.— The primer is illustrated in figure 29. It is held in place in the primer holder by staking the rim of the primer body on the upper rim of the primer holder. The as-

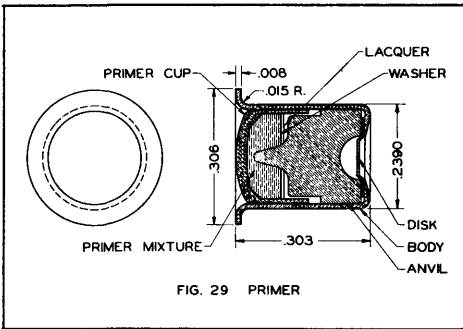

sembled primer is .239" in diameter at the base, .306" at the upper rim, and .303" deep. The body and the anvil are made of brass, and the primer cup is an alloy of copper, silicon, and zinc. The disk is lead foil, and the washer is manila foil. The primer charge is .70 grains of primer mixture.

**40 ACTION**

a. The rocket propels itself from the launcher when the propellant is ignited.

b. When the rocket reaches the end of its trajectory or strikes the target, the firing pin continues forward, overcoming the resistance of the firing-pin spring by inertia.

c. The firing pin drives into the primer, causing it to explode.

d. The flame of the primer ignites the bursting charge.

e. The bursting charge deflagrates, rupturing the head and igniting and scattering the chemical charge. The action of the rocket is completed.

**41 BALLISTICS**

Range, effective ----- 300 yd.  
Effective area covered  
by smoke -----  
Launcher employed ---- M1A1 and M9

**42 PAINTING AND MARKING**

a. Painting.— (1) Motor.— The motor is painted olive drab in the standard manner.

(2) Head.— All exterior surfaces of the head are coated with blue-gray lacquer.

b. Marking.— A 1/2" yellow band is painted about the motor, 1-1/2" from the nose. Centrally on the container, in three lines of yellow figures and letters, appears the following marking:

(3/16" figures) ROCKET, 2.36 INCH, T26  
(3/4" figures) WP-SMOKE  
(3/8" figures) LOT 0000-0.0-00

**43 PACKING**

No packing has been considered for this rocket as yet, but it may be safely assumed that the type of packing adopted for the M6A1 rocket will be closely followed. If twenty T26 rockets are packed in fiber containers, which are in turn loaded into a wooden packing box, the weight and dimensions of the loaded box will be nearly identical to the weight and dimensions of the loaded box of M6A1 rockets.

**44 SAFETY PRECAUTIONS**

a. Do not remove the safety pin until the round is to be fired and its nose is in the launcher.

b. After the safety pin has been removed, do not drop the rocket. A fall of 1' can function the fuze.

**DECLASSIFIED**

**NOTES**

**DECLASSIFIED**

NOTES

**DECLASSIFIED**

c. Face guards and gloves must be worn when the rocket is fired.

d. Burning particles of white phosphorus landing on the skin inflict serious burns. Personnel should approach burning rockets with extreme care.

e. Rockets which have been un-

packed but not fired should be returned to their original packing containers. The safety pin and nozzle disk must be in place.

f. Rockets should be stored in a cool, dry place. They should not be stored where temperatures exceed 120° F., and they should not be exposed to the direct rays of the sun.

SECTION VIII



ROCKET, SMOKE, HC, 2.36", T27

45 REASON FOR DEVELOPMENT

In accordance with the policy outlined in paragraph 37 of section VII, the T27 HC rocket has been developed.

46 GENERAL

a. Appearance.— It will be noted from figure 30 that the head of the T27 rocket is shorter than the head of the T26 rocket shown in figure 25. The HC filler loaded into the T27 is denser than the WP filler loaded into the T26. Specifically, 450 gm. of HC are loaded into the shorter T27 head and 405 gm. of WP are loaded into the longer T26 head. In order that the two rockets have identical weight, the difference in the head design was necessary

b. Motor.— The M6A1 rocket motor with minor changes in the fuze body is used. See paragraph 38 of section VII for a discussion of the motors to be used with this smoke rocket in the future.

c. Use.— Tactical requirements call for a smoke rocket for both offensive and defensive situations. HC smoke is a screening agent that has no effect upon the human body. For this reason it can be used to cover the advance or retreat of friendly troops. It may be

used to blind enemy fortifications or groups of enemy personnel but it is not as suitable for this purpose as WP smoke.

d. General data.—

Length, over-all	-----18-5/16"
Length of head	----- 4-3/4"
Diameter	----- 2.36"
Diameter of head	----- 2.30"
Weight of complete round	---- 3.4 lb.
HC charge	----- 450 gm.
First-fire charge	----- 18 gm.

e. Components.— The components of the T27 HC rocket are the motor assembly and the head assembly. The head assembly will be discussed in the following paragraph.

47 HEAD ASSEMBLY

The head assembly consists of the container and its chemical charge, the container cup, the first-fire charge, the impregnated disk, the closure plate and collar. For the purpose of this description, the fuze body, the primer holder, the primer, and the fuze-body spacer will be considered as components of the head assembly. They are actually modified components of the the M6A1 motor assembly.

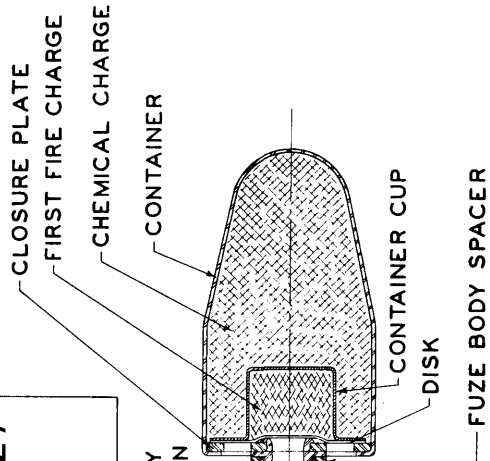
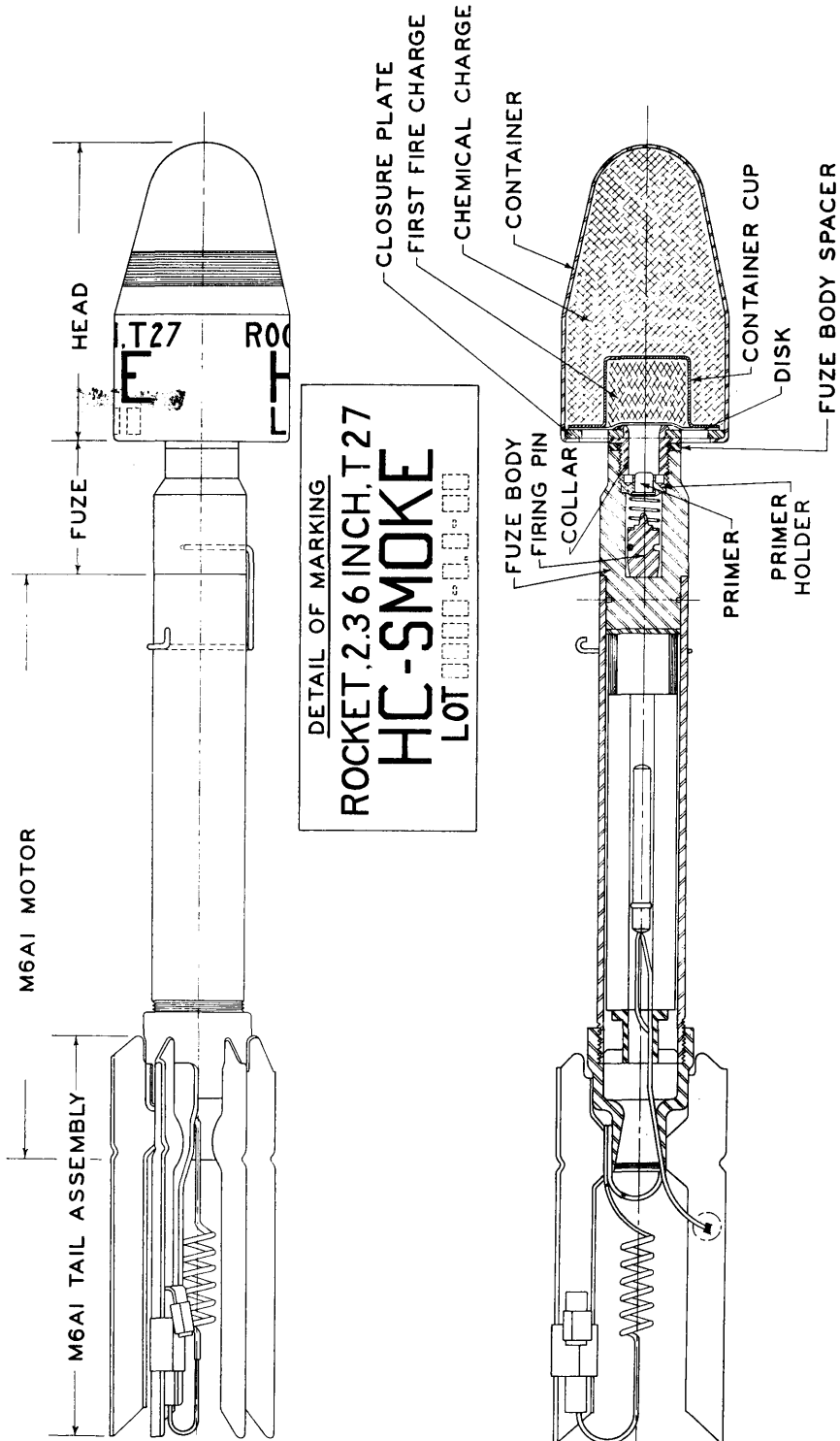
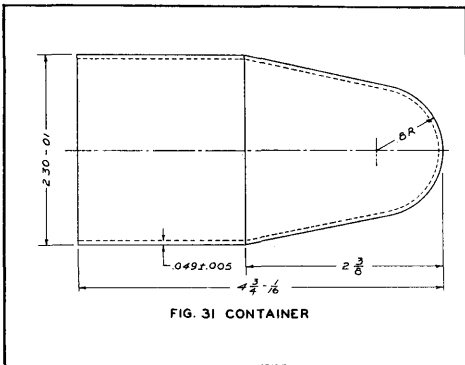

FIGURE 30. - ROCKET, SMOKE, HC, 2.36", T27

a. Container.— The steel container is illustrated unassembled in figure 31. The forward end is curved



on a radius of .8". The open rear end has a diameter of 2.30", and the wall thickness is .049".

b. Chemical charge.— The chemical charge is approximately 450 gm. of HC mixture cast to leave space for the container cup.

c. Container cup.— The container cup is made of zinc .010" thick. It is 1-1/8" in diameter and 29/32" deep and has a rim with a diameter of 2.1".

d. First-fire charge.— This charge is 18 gm. of starter mixture. The container cup, with the contained first-fire charge, is placed in the recess formed in the chemical charge.

e. Impregnated disk.— This disk, approximately 2.1" in diameter, is laid over the surface of the first-fire charge, the rim of the cup, and the adjoining chemical charge. It is held in place by a disk of adhesive plaster.

f. Closure plate.— The closure plate is a steel disk 2.18" in diameter and .1225" thick. It has a central hole .615" in diameter and four equally spaced outer holes each 3/8" in diameter.

g. Collar.— The collar has the shape shown in figure 32. It is similar

to the collar in the M26 rocket. It is 1" in diameter and 3/4" thick. The central hole is 7/16" in diameter. The cham-

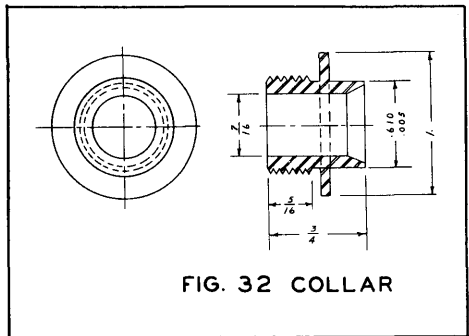

fered rim is fitted in the central hole of the closure plate and silver solder poured over the juncture. The closure plate and collar assembly is then fitted over the disk of adhesive plaster. The rim of the container is then turned tightly over the plate, closing the head assembly.

h. Fuze body.— This is the same fuze body as that assembled with the T26 rocket.

i. Primer holder.— This is the same component as that assembled with the T26 rocket.

j. Primer.— This is the same primer as that assembled with the T26 rocket.

k. Fuze-body spacer.— This is the same component as that used with the T26. It is assembled in the same way.

## 48 BALLISTICS

Range, effective ----- 300 yd.  
Effective area covered  
by smoke -----  
Launcher employed ---- M1A1 and M9

## 49 ACTION

a. The rocket propels itself from the launcher upon ignition of the propellant.

**T27  
ROCKET**

b. At the end of its trajectory, or upon striking the target, the firing pin continues forward, overcoming the resistance of the firing-pin spring by inertia.

c. The firing pin drives into the primer, causing it to explode.

d. The flame of the primer ignites the first-fire charge.

e. The burning first-fire charge ignites the HC mixture. The first smoke generated escapes through the holes in the closure plates. As the whole charge begins to burn, the container melts and the smoke escapes freely. The action of the rocket is completed.

## **50 PAINTING AND MARKING**

a. Painting.— (1) Motor.— The motor is coated with olive-drab lacquer.

(2) Head assembly.— All external surfaces of the head assembly are coated with blue-gray lacquer.

b. Marking.— A 1/2" band of yellow lacquer enamel is painted about the head, 1-1/2" from the nose. Centrally on the head appear the following three lines of circumferential marking:

(3/8" figures) ROCKET, 2.36 INCH, T27  
(3/4" figures) HC - SMOKE  
(3/8" figures) LOT 0000-0.0-00

## **51 PACKING**

No packing has yet been developed for this rocket, although the assumed packing of the T26 outlined in section VII is applicable.

## **52 SAFETY PRECAUTIONS**

a. Do not remove the safety pin until the round is to be fired.

b. After the wire has been removed, a fall of 1' can function the fuze. Do not drop the rocket after the safety pin has been removed.

c. Face guards and gloves must be worn when the rocket is fired.

d. Rockets which have been unpacked but not fired should be returned to their original packing containers. The safety pin and nozzle disk must be in place.

e. Rockets should be stored in a dry, cool place. They should not be stored where temperatures exceed 120° F., and they should not be exposed to the direct rays of the sun.

**DECLASSIFIED**

**NOTES**

**DECLASSIFIED**



NOTES

**DECLASSIFIED**

**DECLASSIFIED**

## SECTION IX

### ROCKET, INCENDIARY, 2.36", T31

#### 53 REASON FOR DEVELOPMENT

In accordance with the policy outlined in paragraph 37 of section VII, the T31 incendiary rocket has been developed.

#### 54 GENERAL

a. Appearance.— It will be noted from figure 33 that the body assembly of the T31 is shorter than the body assemblies of the T26 or T27 rockets. Since the incendiary charge of the T31 is denser than either HC or WP, the body of the T31 must be smaller in order not to exceed the total weight permitted for the rocket.

b. Motor.— The M6A1 rocket motor with minor changes in the fuze body is used. See paragraph 38 of section VII for a discussion of the motors to be used with this incendiary rocket in the future.

c. Use.— Theoretically, there is widespread use for an incendiary rocket. It should prove effective against tanks, wooden dwellings, and in interior portions of fortifications. At the present time however, it is doubtful whether this rocket will be standardized, since the incendiary charge which it carries is small. Initial production of the rockets has gone to interested service boards for testing. These tests will determine whether or not it will be standardized.

#### d. General data.—

Length, over-all ----- 17-11/16"  
Length of head ----- 4-1/8"  
Diameter ----- 2.36"  
Diameter of head ----- 2.30"  
Weight of complete round ---- 3.4 lb.  
Thermite charge (estimated) - 500 gm.  
First-fire charge ----- 18 gm.

e. Components.— The components of the T31 incendiary rocket are the motor assembly and the head assembly. The head assembly will be discussed in the following paragraph.

#### 55 HEAD ASSEMBLY

The head assembly consists of the container, ring, collar, container cup and closure plate. For the purpose of this description, the fuze body, primer holder and primer will be considered as parts of the head assembly. They are actually modified components of the M6A1 motor assembly. The container has a chemical charge, and the container cup has a first-fire charge.

a. Container.— The container is identical to the container of the T27 rocket except that it is 4-1/8" long — 5/8" shorter than the T27.

b. Ring.— The ring is steel .06" thick, .25" wide, and 2.202" in diameter. It is spot welded at 45° intervals to the inside of the container, 5/16" from the open end.

c. Collar.— The collar is identical to the T27 collar. It is assembled to the closure plate in the same way as the T27 collar and closure plate.

d. Container cup.— This component is identical to the T27 component.

e. Closure plate.— This component is identical to the T27 component.

f. Fuze body.— The T26, T27, and T31 rockets use the same fuze body.

g. Primer holder.— The T26, T27, and T31 rockets use the same primer holder.

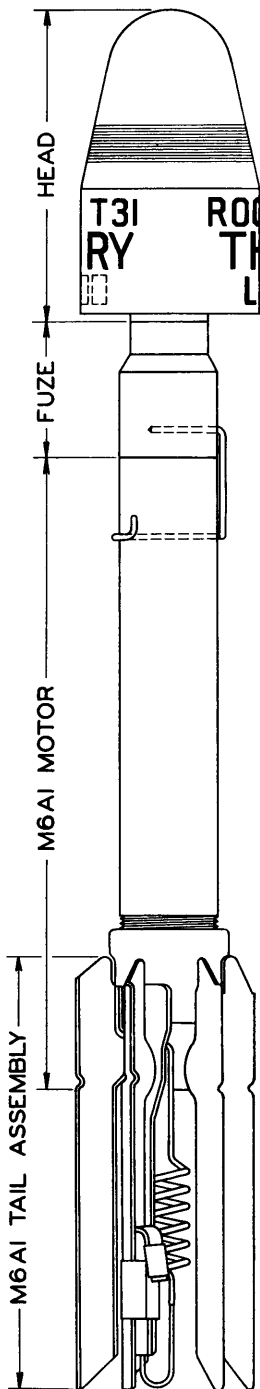

DETAIL OF MARKING  
**ROCKET, 2.36 INCH, T31  
 TH-INCENDIARY**  
 LOT 0000-0000-0-00  
 YEAR MONTH  
 MANUFACTURER'S INITIALS

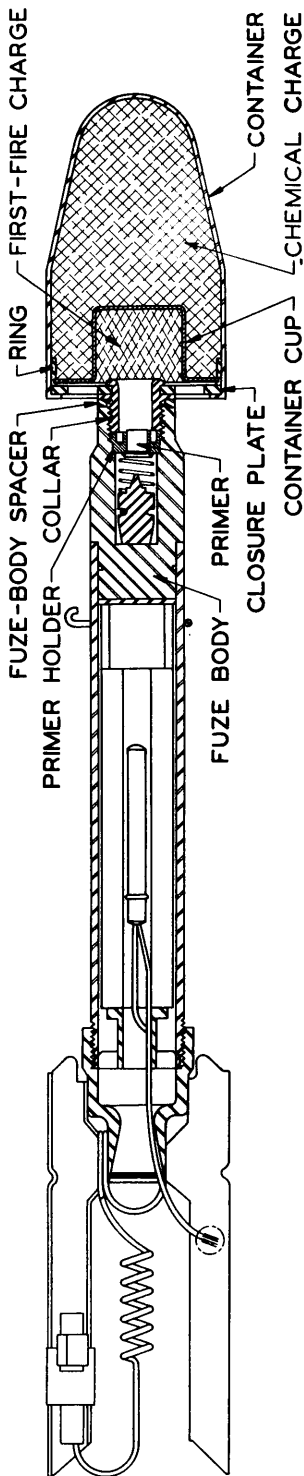

FIGURE 38. - ROCKET, INCENDIARY, 2.36", T31

h. Primer.— The T26, T27, and T31 rockets use the same primer.

i. Chemical charge.— Into the container is pressed a charge of approximately 500 gm. of thermitite.

j. First-fire charge.— The first-fire charge, pressed into the container cup, consists of 18 gm. of first-fire composition.

## 56 BALLISTICS

Range, effective ----- 300 yd.  
Heat generated by rocket -----  
Burning time of charge -----  
Launcher employed ---- M1A1 and M9

## 57 ACTION

a. The rocket propels itself from the launcher upon ignition of the propellant.

b. When the rocket reaches the end of its trajectory, or strikes the target, the firing pin continues forward, overcoming the resistance of the firing-pin spring by inertia.

c. The firing pin drives into the primer, causing it to explode.

d. The flare of the primer flashes through the central hole of the primer holder and ignites the first-fire charge.

e. The first-fire charge burns and ignites the thermitite charge, and the action of the rocket is complete.

## 58 PAINTING AND MARKING

a. Painting.— (1) Motor.— The motor is painted olive drab in the standard manner.

(2) Head.— All exterior surfaces of the head are coated with blue-gray lacquer.

b. Marking.— A 1/2" band of purple lacquer enamel is painted about the head, 1-1/2" from the nose. Centrally on the head appear the following three lines of circumferential marking:

(3/8" figures) ROCKET, 2.36 INCH, T31  
(3/4" figures) TH - INCENDIARY  
(3/8" figures) LOT 0000-0000.0-00

## 59 PACKING

No packing has yet been developed for this rocket, although the assumed packing of the T26 outlined in section VII is applicable.

## 60 SAFETY PRECAUTIONS

a. Do not remove the safety pin until the round is to be fired.

b. After the pin has been removed, a fall of 1' can function the fuze. Do not drop the rocket after the safety pin has been removed.

c. Face guards and gloves must be worn when the rocket is fired.

d. The heat generated by the thermitite is intense, and personnel should exercise care in approaching a burning rocket.

e. Rockets which have been unpacked but not fired should be returned to their original packing containers. The safety pin and nozzle disk must be in place.

f. Rockets should be stored in a dry, cool place. They should not be stored where temperature exceeds 120° F., and they should not be exposed to the direct rays of the sun.

NOTES

**DECLASSIFIED**

**DECLASSIFIED**

**DECLASSIFIED**

**NOTES**

**DECLASSIFIED**

CHAPTER 3—3.25" TARGET ROCKETS



61 GENERAL

The rocket, target, A.A., 3.25", M2 (see fig. 34), was designed for use as a high-speed target for firing practice with automatic anti-aircraft weapons. The rocket consists of a motor, a motor extension, a nose, and three plywood fins. The propellant is a solvent-extruded double-base powder (40 percent nitrocellulose) extruded into cylindrical sticks 5" long and 7/8" in diameter with a 5/16" hole through the center. The propelling charge is ignited by an electric squib assembled within the rocket. This rocket is a direct copy of the British 3" U. P. projectile.

62 GENERAL DATA

Length ----- 59"  
Diameter ----- 3.25"

Width across fins ----- 24"  
Weight ----- 37.5 lb.  
Propelling charge ----- 3.2 lb.  
Igniter (black powder) ----- 0.78 oz.  
Muzzle velocity ----- 2,200 yd.

63 ROCKET, TARGET, FLARE, A.A.,  
3.25", M2A1

When a flare is added to the M2 rocket for anti-aircraft target practice at night, the resulting projectile is designated as the rocket, target, anti-aircraft, 3.25", M2A1. The flare burns for 15 to 20 seconds from the beginning of flight.

64 REFERENCES

TM 4-236, Instructions for use of Rocket, Target, M2 by Anti-aircraft Units; TM 9-390, Target Rocket Projector, M1.

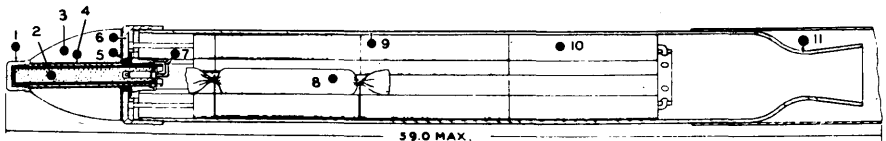

- |                                |                      |               |   |
|--------------------------------|----------------------|---------------|---|
| ① Nose                         | ④ Pipe               | ⑦ Squib wires | ⑩ Propelling charge   |
| ② Black powder ignition charge | ⑤ Insulating washers | ⑧ Igniter bag | ⑪ Nozzle  |
| ③ Ogive                        | ⑥ Cap                | ⑨ Tube body   | (Note: Drawing shows only the motor or combustion chamber.) |

FIGURE 34. - ROCKET, TARGET, A.A., 3.25", M2



**DECLASSIFIED**

**NOTES**

**DECLASSIFIED**



## CHAPTER 4—4.5" ROCKET AND LAUNCHERS

## SECTION I

## ROCKET, H.E., 4.5", M8

## 65 GENERAL

a. Rocket.— The rocket, H.E., 4.5", M8 (see fig. 43) is a round of ammunition for use by ground forces against ground targets. The main issue of the rocket initially, however, will be to the Air Forces for use against ground targets. The round carries a relatively heavy explosive charge so situated as to provide for complete fragmentation of head and motor. For this reason the round has considerable fragmentation effect as well as the blast effect derived from the heavy charge. The M8 rocket, complete with the M4 fuze and auxiliary booster, is 33.19" long and weighs approximately 38 lb.

b. Launcher.— (1) General. Since the rockets will be initially issued to the Air Forces, the launchers are being issued in clusters of three — one cluster to be mounted under each wing

of the plane. (See figs. 35 and 36.) Each launcher is a smooth-bore plastic tube 4-9/16" in internal diameter and approximately 10' in length. At the breech end of each tube are three latches. One of these (1) holds the rocket in place in the launcher; the other two make electrical contact with the two contact rings (3) of the rocket. The two contact latches (2) are connected by wires to the firing-selector box. This box, located in the cockpit of the plane, operates on the plane's electrical system. On each cluster there is a device which enables the pilot to jettison the launchers after the rockets are fired.

(2) Operation.— The trigger, mounted on the joy stick of the plane, is connected to the firing-selector box. The box enables the pilot to fire each rocket singly or the entire group auto-

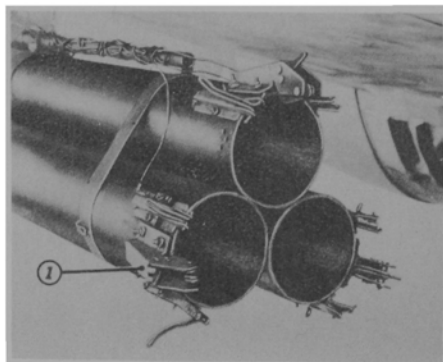

FIGURE 35. - LAUNCHER, ROCKET, 4.5", 3-TUBE, A.C., T30. END VIEW SHOWING LAUNCHER READY FOR LOADING

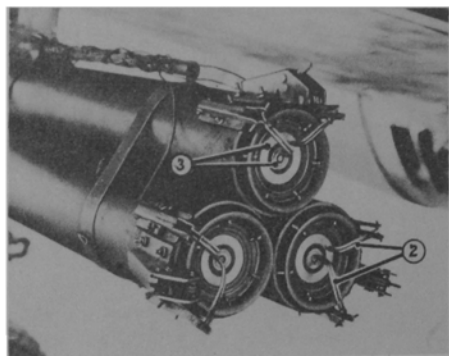

FIGURE 36. - LAUNCHER, ROCKET, 4.5", 3-TUBE, A.C., T30. END VIEW SHOWING ROCKETS IN TUBE AND ELECTRICAL CONTACTS IN PLACE

matically at 1/10-second intervals. When the rockets are fired singly, the selector determines the sequence of firing. When the trigger is pressed, an electric current passes into the rocket through the two contact rings. This current initiates the igniter, which in turn initiates the rocket motor.

c. Issue.— It is contemplated that the M8 rocket will be used in either a single- or multiple-barreled launcher that will serve as an infantry accompanying weapon. The launcher and rocket will be generally similar in use and effect to the 105-mm howitzer and, as such, will prove an important adjunct to the fire power of infantry troops. No information is available concerning the organizational assignment of the weapon, but Ordnance personnel will see it in quantity in the near future. Familiarity with the ammunition, its action and functioning, and its fuzing and packing will prove invaluable in handling it properly in the field.

d. Reference.— SNL S-9 lists the rocket and gives pertinent data.

## 66 COMPONENTS

The term "complete round" as applied to rockets includes the rocket head and fuze, the rocket motor and igniter, and all components required for proper functioning.

## 67 FUZE

The M8 rocket differs from ammunition fired from cannon in that it does not rotate. To design a fuze that would be bore safe under these conditions presented a problem that was successfully solved by the development of the Fuze, P.D., M4. The M4 fuze is safe by reason of a slider that interrupts the explosive train and moves out of its interrupting position only after forward acceleration of the rocket is complete. The slider is retained in the interrupting position by means of a

pin. Through the release on set-back of a prisoned ball, the pin is freed, permitting the slider to move into the armed position. The fuze consists of a body, head, firing-pin assembly, slider assembly, related parts, explosive components, and auxiliary booster. More than a general description of the various components is not included. The diagram of the fuze and the description of its action will give an adequate acquaintance with the fuze.

a. Body.— (1) The base (see fig. 37) is designed to screw into the shell adapter and is threaded for that purpose just below the shoulder. The forward end of the body has a circular ledge to seat the head and to form a projection, or nose, over which the head fits and into which the two flash holes are drilled. The flash holes are parallel to each other and enter the body longitudinally. One flash hole (instantaneous) is 0.205" in diameter, widening at the top to 0.315" to seat the primer. The second flash hole (delay), 0.325" in diameter for the lowest third of its length, is 0.445" wide for the upper two-thirds. These two flash holes open into a transverse hole, 0.380" in diameter and extending approximately 1-3/4" into the body. This transverse hole houses the setting pin, which has the function of determining the instantaneous or delay action of the fuze. A third hole, parallel to the flash holes, 0.88" from the longitudinal axis of the body and 0.127" in diameter, contains the retaining pin. This pin rides in an 0.127" circumferential groove in the setting pin, permitting the setting pin to rotate but not to move longitudinally. In order to lock the setting pin in one of two positions, two notches, 180° apart, are formed in the setting pin. A ball bearing under spring tension fits in one of these notches. Some pressure is needed to rotate the setting pin. This disengages the ball and re-engages it in the opposite notch. The spring and ball fit into a hole (the fourth hole)

**M4  
FUZE**

**DECLASSIFIED**

Fig. 37 FUZE, ROCKET, P.D., M4

**DECLASSIFIED**

DECLASSIFIED

DECLASSIFIED

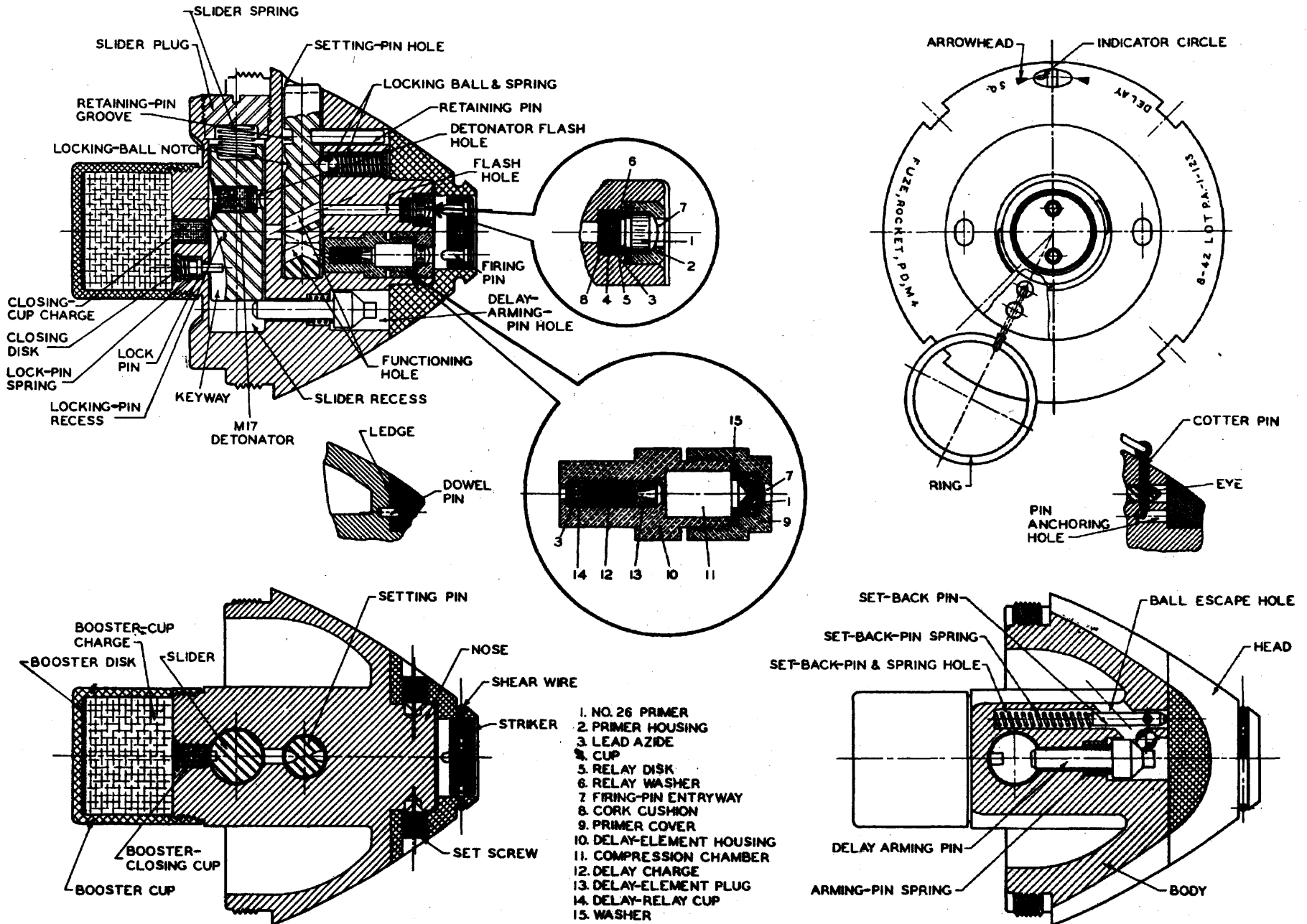

FIGURE 37. - FUZE, POINT DETONATING, M4

DECLASSIFIED

DECLASSIFIED

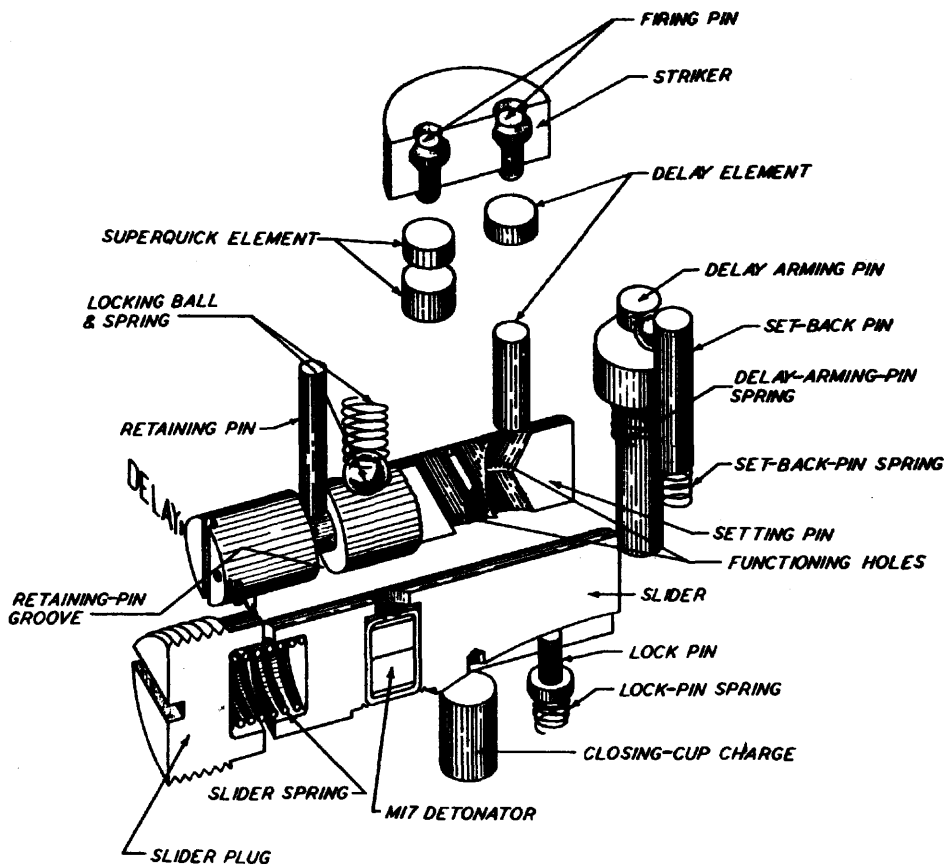

FIGURE 38. - POSITION AND NOMENCLATURE OF M4 ROCKET FUZE IN UNARMED POSITION

leading into the setting-pin hole. This fourth hole is 0.645" from the longitudinal axis of the body and is 0.250" in diameter. Both the locking-ball-and-spring hole and the retaining-pin hole open on the body ledge, and both are radially aligned. Diametrically opposite these two holes and opening on the body ledge is the fifth hole, paralleling the flash holes. This hole is 0.185" in diameter for the lowest third of its length, opens sharply to 0.310", and is 0.373" for the upper half of its length. This hole houses the delay arming pin, which prevents movement of the slider. The delay-arming-pin hole opens into a second transverse hole, which is parallel to and below the setting-pin hole. Into this second horizontal hole, 0.5" in di-

ameter and 2-1/4" deep, fits the slider. This hole is called the slider recess.

(2) The body consists of an oblong portion with a dome-shaped portion at one end. (See fig. 37.) The narrow faces of the oblong fit solidly against the sides of the dome, but between the wide faces of the oblong and the inner sides of the dome there are two open recesses. All the holes mentioned in the preceding paragraph are contained in the oblong portion. Leading at an angle of 45° from the wall of the upper end of the delay-arming-pin hole is a hole 0.195" in diameter that opens at its lower end into one of the recesses mentioned above as being between oblong and dome. This hole is referred to

**M4  
FUZE**

**DECLASSIFIED**

FIGURE 39. - PARTIAL ARMING  
OF M4 FUZE 

**DECLASSIFIED**

DECLASSIFIED

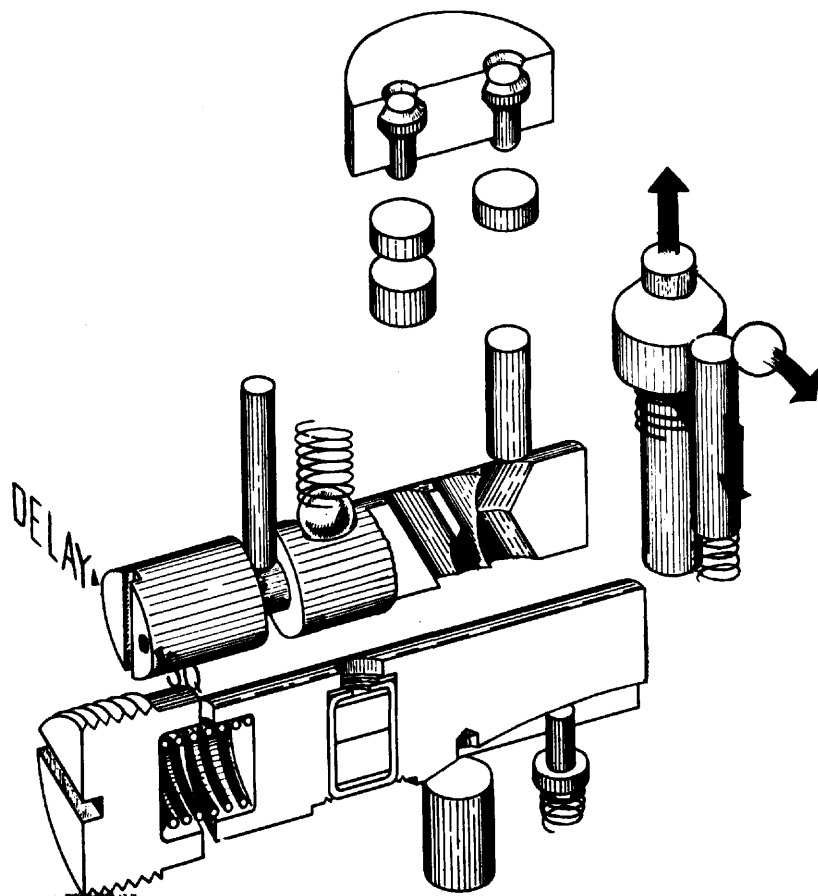

FIGURE 39. - PARTIAL ARMING OF M4 FUZE

DECLASSIFIED

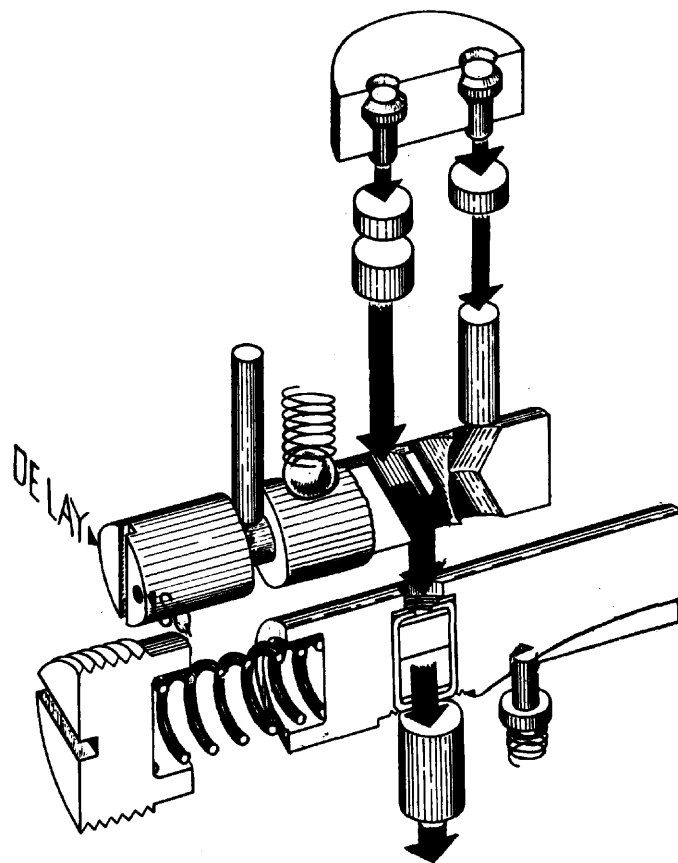

FIGURE 40. - SUPERQUICK FUNCTIONING OF M4 FUZE

as the ball escape hole and is the only hole not formed at right angles. The ball escape hole intersects a sixth hole, parallel to the flash holes. This sixth hole, the set-back-pin-and-spring hole, is 0.151" in diameter and extends downward from the ledge formed on the upper side of the body. The set-back-pin-and-spring hole intersects none of the transverse holes and is approximately 1-3/4" deep.

(3) In the bottom surface of the fuze body there is a single central flash hole, or booster-closing-cup channel, 0.2" in diameter. A second hole, the lock-pin hole, is located 0.34" from

the closing-cup channel and opens into the slider recess. It houses the lock pin and lock-pin spring. After insertion of the pin and spring, the hole is closed at the bottom with a steel closing disk, 0.245" in diameter and 0.0329" thick.

(4) The body is a malleable-iron casting given a good machine finish and cadmium plating. It weighs 1.7 lb. and has a maximum height of 2.51" and a maximum width of 3.21".

b. Head.— The head is made of aluminum alloy and weighs 575 grains. It is cast to a shape which allows it to fit over the body projection and rest on

DECLASSIFIED

DECLASSIFIED

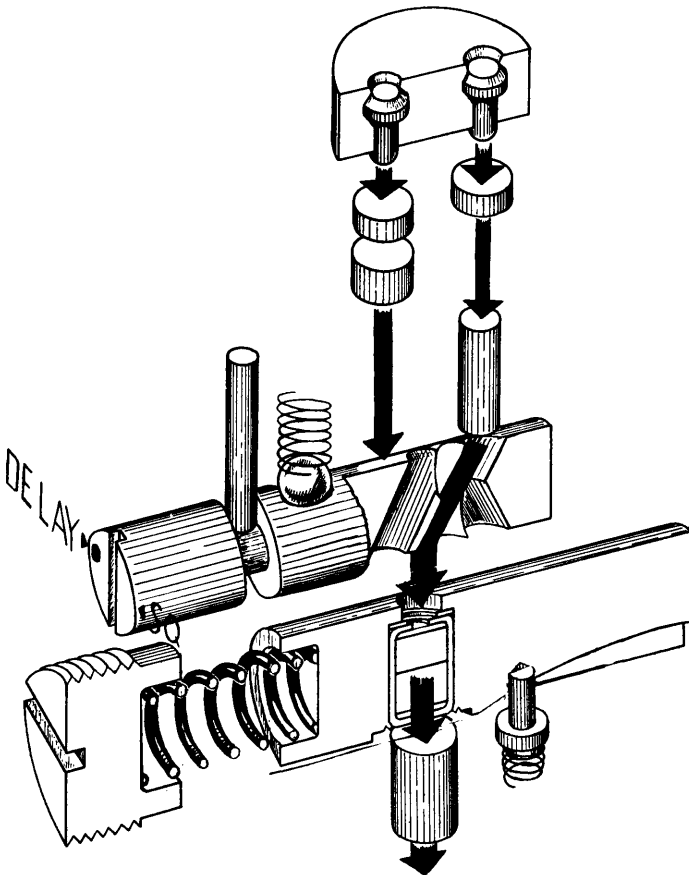

FIGURE 41. - DELAY FUNCTIONING OF M4 FUZE

the body ledge. The central hole, which fits over the body projection, is 0.998" in diameter. Immediately above this hole there is a shoulder which narrows the hole to 0.7". This upper hole houses the firing-pin assembly. The bottom of the head is a flat base that fits on the body ledge. Through the sides of the head are two holes, each threaded to take a commercial setscrew. These cone-pointed setscrews engage two holes, 5/32" wide and .1" deep, in the walls of the body projection and tighten the head onto the body. The base of the head, where it rests on the body ledge, closes the holes leading downward

from the body ledge.

c. Booster.— The booster assembly consists of a booster cup and a booster disk. The cup is aluminum alloy, weighs 261 grains, and is 1.123" in internal diameter and 1.288" in external diameter. The upper 0.3" of the inner wall is threaded to fit the lower projection of the fuze body, where, after being screwed on, it is secured by staking. The booster disk is onionskin paper that fits into the bottom of the cup and is inserted prior to loading of the booster pellet.



d. Firing-pin assembly.— This assembly consists of the striker, two firing pins, and a shear wire. The striker is an aluminum-alloy disk, 0.695" in diameter and 0.20" thick. Two holes pass through the faces of the disk, each hole shaped to seat a firing pin. The two holes are 0.220" apart and equidistant from the center of the striker. A diametric hole is drilled through the striker to house the shear wire. The shear wire, which is 1.15" long, 0.04" in diameter, and made of brass, passes through the shear-wire hole and through the walls of the firing-pin recess in the head. The wire keeps the striker in place under the normal shocks incidental to handling. Each of the firing pins is nipple shaped and made of cadmium-plated steel. They extend 0.08" below the surface of the striker and are held in place in the striker by a 340° crimp of the striker metal.

e. Slider assembly.— The assembly consists of the slider, slider spring, slider plug, lock pin, lock-pin spring, and closing disk. The slider is a cadmium-plated steel rod, 0.408" in diameter, 1.47" long, and weighing 490 grains. One end is recessed to a depth of 0.15" to seat the slider spring. The wall of the opposite end is keywayed on a curve (radius of 1.75") to provide a camming surface. This keyway extends a little more than half the length of the slider. It is interrupted near the inner end by a hole, the lock-pin recess, 0.093" in diameter. In this keyway the lock pin rides until it slips into the lock-pin recess. At a distance of 0.94" from the spring-recess end of the slider are drilled two concentric holes. The lower hole, 0.374" deep and 0.242" in diameter, houses the detonator assembly and is beveled outward at the bottom. Above it is a hole 0.152" in diameter drilled through the remaining thickness of the slider. This upper hole is the detonator flash hole. The slider spring, made of steel music wire, is seated in the recess at

the end of the slider and is held in place by the slider plug. The plug is a threaded steel cap which screws into the open end of the slider recess and holds the slider assembly in place. The outer face of the plug is slotted to take a screwdriver, and the opposite end is recessed in the same manner as the slider to seat the slider spring. The lock pin and lock-pin spring are housed in the lock-pin-spring hole described in a(3) above. Two-thirds of the way along its length, the lock pin has a 0.5" shoulder, 0.05" thick. This shoulder fits into the lock-spring hole. Below the shoulder, the pin is 0.120" in diameter and 0.07" long to hold the lock-pin spring in place. Above the shoulder, the pin is 0.20" long and 0.08" in diameter. It is this longer and more slender portion of the pin that engages the keyway of the slider and under the tension of the spring moves into the lock-pin recess, locking the slider in position. The lock-pin spring is made of steel music wire, has three free coils, and is held in place in the lock-pin hole by the closing disk. The latter, described in a(3) above, is secured by crimping.

f. Related parts.— (1) Dowel pin.— This steel pin, 0.20" long and 0.125" in diameter, fits into matching holes drilled into the surfaces of the body ledge and the base of the head. It prevents rotary motion of either part in the same manner as the set-screws prevent vertical motion of the parts.

(2) Ring and pin.— A cotter pin, ring engaged, passes through a transverse hole in the side of the body that intersects the set-back-pin hole. The cotter pin is fitted through an eye in the set-back pin when the latter is in its most forward position. The cotter pin then engages the hole in the opposite wall of the set-back-pin hole and enters another shallow and narrow hole, opening on the body ledge. Prior to assembly of the head, a tool is inserted in this

hole and the ends of the cotter pin are bent down, so that the pin is secured in place.

(3) Setting pin.— In addition to the circumferential groove and notches described in a(1) above, there is a set of holes drilled through the setting pin. These holes determine the functioning of the fuze. The holes, three in all, are drilled through the pin at different angles and have the appearance, in cross section, of a letter X with an additional leg, . Each hole is 0.14" in diameter, and the two holes forming the X are approximately 1/16" apart at the surface of the pin. The parallel leg intersecting one leg of the X forms a common opening with the leg at the surface. The arrangement of the holes and their location beneath the instantaneous and delay flash holes permits selective functioning of the fuze by 180° rotation of the setting pin.

g. Explosive components of instantaneous and delay flash holes.

(1) Instantaneous-flash-hole components.— The explosive components in the instantaneous flash hole consist of a No. 26 primer and a relay, both of which are held in place in the flash hole by a primer housing. The No. 26 primer, discussed in volume 1, is the standard cal.30 primer. The relay assembly consists of a charge of 1.54 grains of lead azide pressed into an aluminum cup under a pressure of 5,000 lb./sq.in. The relay cup is 0.193" in diameter and 0.120" deep and has a slight rim. The charge fills the cup to a depth of 0.095". A relay disk of pink onionskin paper, 0.002" thick, is placed on the charge and covered with an aluminum relay washer of the same thickness. The cup is then closed with a 360° crimp, which exposes the pink disk. The primer is fitted into the primer housing, which is a brass cup, 0.313" in diameter, recessed to fit tightly over the primer and drilled at the bottom with a 0.10" hole to permit the firing

pin to contact the primer. The relay assembly, pink side up, is fitted into the flash hole and rested on a disk-shaped compressed-cork relay cushion that has been previously inserted and rests on the inner shoulder of the flash hole. The primer housing is then inserted, located on the upper shoulder, and secured by staking.

(2) Delay-flash-hole components.— The explosive components of the delay flash hole are all parts of the delay-element assembly. The two major metal parts of this assembly are the primer cover and the delay-element housing. The former is similar to the primer housing in the instantaneous flash hole except that the walls are higher and are internally threaded at the rim. The primer cover is 0.44" in diameter and 0.395" high and is internally formed to seat the No. 26 primer and allow contact of the primer and firing pin. The delay-element housing is a brass member, internally shaped to seat several components of varying diameters. It is 0.835" long and 0.44" in diameter and is externally threaded to screw into the primer cover. The two metal components when screwed together slip readily into the flash hole, the exterior of the housing being shaped to match the internal shape of the lower flash hole. When the two components are fitted together, there is an internal void space between them that forms a compression chamber. Below this chamber in the housing is a long, narrow hole 0.425" deep and 0.124" in diameter. At the bottom it narrows to a small concentric hole 0.045" long and 0.051" in diameter. Loaded into this long hole successively are a delay-relay assembly, a delay charge, and a delay-element plug. The delay-element plug, which is nearest the compression chamber, is a brass plug, 0.123" in diameter and 0.102" thick, having a conical hole of minimum diameter (on the lower face) of 0.027" and opening outward and upward with a taper of 0.3" diameter per inch of length. This conical hole col-

lects the flame of the primer from the compression chamber and presents it to the delay element as a concentrated spit of fire. The delay charge, below the delay-element plug, is approximately 1.23 grains of grade "A-5" Army black powder, compressed under a pressure of 60,000 lb./sq.in. The powder is varied in quantity to give a 0.1-second delay. Below the delay charge is the delay-relay assembly. This assembly consists of an 0.77-grain charge of lead azide pressed into a delay-relay cup under a pressure of 25,000 lb./sq.in. The cup is 0.122" in diameter and 0.155" deep and has an inward bulge in the base. After insertion of the lead azide, the walls are crimped inward at an angle of 45°. The flat portion of the bottom of the cup is coated with red N.R.C. compound, and the assembly is placed in the bottom of the long hole and compressed under a pressure of 60,000 lb./sq.in. before the compound is dry. This compression flattens the crimped walls of the cup. The delay-element plug, and all the components under it are held in place by means of a 45° circular crimp of the adjacent walls. To seal the joint between housing and primer cover, a copper washer is inserted.

h. Slider explosive components.— The M17 detonator is assembled in the slider. This is the same detonator assembled in the M53 P.D. fuze (see vol. 3). The detonator is inserted into the slider-detonator recess, coming to rest on a washer-shaped compressed-cork detonator cushion which has already been inserted and located on the inner shoulder of the recess. The colored end of the detonator is flush with the counterboring at the large end of the detonator recess, and it is secured in place by crimping.

i. Booster-closing-cup assembly.— This explosive component consists of a booster closing cup and a booster-closing-cup charge. The cup is gilding metal, slightly rimmed, 0.19"

in diameter, and 0.343" deep. Into the cup is pressed 3.25 grains of tetryl under a pressure of 10,000 lb./sq.in. The assembly is fitted into its recess in the bottom of the head and secured with a 360° crimp.

j. Booster charge.— The booster assembly consists of a booster cup, booster-cup charge, and booster disk. The cup, made of aluminum alloy, is 1.288" in diameter, 1.17" deep, and threaded internally at the rim to screw onto the fuze body. The booster disk, onionskin paper 0.002" thick, is inserted in the bottom of the cup, and the booster charge of 329 grains of tetryl, in pellet form, is loaded into the cup.

k. Auxiliary booster.— In order to make certain that a high-order detonation of the explosive charge takes place, an auxiliary booster is fitted into the fuze-well cup. The auxiliary booster assembly fits readily into the cup and is held in place by the booster cup of the fuze when the fuze is screwed into the shell.

(1) Components.— The M1 auxiliary booster consists of a tube assembly, a bottom, and a charge. The tube assembly consists of a waterproof chipboard tube, 3-5/8" long, 2.65" in diameter, and having walls 0.15" thick; and an end plate, which is a steel disk grooved at the rim to allow it to be crimped over the rim of the tube. The bottom is a chipboard disk shaped like the nose plug and having a diameter across the rim of 2.50" and a smaller diameter of 2.10". The charge is 0.87 lb. of cast TNT or 0.84 lb. of flake TNT.

(2) Assembly.— The end plate is crimped over one rim of the tube, and the charge is loaded. The bottom is fitted into the open end of the tube and the rim of the tube is roll-crimped to hold the bottom in place. The bottom is fitted with its rim against the charge.

(3) Marking.— Stenciled in white 1/8" letters circumferentially about the end plate are the nomenclature and use

of the booster - "AUXILIARY BOOSTER, M1, FOR FUZE, ROCKET, P.D., M4." Across the middle of the end plate are stenciled in white 3/16" letters the words "THIS END UP," and below these words is the lot number of the booster.

(4) Packing.— The M1 auxiliary booster is packed with the M4 fuze.

(5) Weight.— The auxiliary booster weighs 0.97 lb. The fuze weighs 2.1 lb. The fuze and auxiliary booster together have a weight of 3.07 lb.

1. Marking and painting.— Circumferentially about the fuze and just above the shoulder are stamped in 1/8" letters and figures the name and model number of the fuze, the date (year and month) of loading, the loader's initials, and the lot number. "FUZE, ROCKET, P.D., M4. 5-43, LOT P.A.-1-123" is a sample stamping. On either side of the setting-pin hole are stamped two arrowheads pointing toward the hole. These arrowheads are coated with red lacquer enamel. A circular depression to one side of the screwdriver slot in the exposed end of the setting pin is coated similarly. Rotation of the pin through 180° places the red ball opposite one of the arrowheads, the latter being marked either "SQ" or "DELAY."

m. Packing.— (1) General.— The M4 fuze and the M1 auxiliary booster are packed together in the M106 fiber container. Fifteen such containers are packed in a wooden packing box.

(2) Container, fiber, M106. Assembled, the container is 8-3/8" long and approximately 3-3/4" in diameter. It consists of a cylindrical body closed at one end by a steel end plate and at the other end by a cylindrical cover. The cover is closed at the free end by a steel end plate which, like the end plate for the body, bulges outward at the center. The walls of the body and cover are waterproofed chipboard. In-

side the body and closely interfitted are two chipboard tubes, both of whose lower rims are flush with the end plate. The intermediate tube is 5-25/32" high, and its upper rim is crimped into a steel ring. It is on this ring that the M4 fuze rests. The second of the two tubes, the inner tube, which fits inside the intermediate tube, is 1-9/16" high. Into this tube fits the base of the auxiliary booster. Between the bottom surface of the auxiliary booster and the end plate is inserted a hair-felt disk, 1/4" thick, that protects the booster from sudden shock. Slipping easily in the intermediate tube is a spacer tube and disk. The spacer tube is 1-1/2" high and is of a diameter to fit the lower fuze body. The disk is chipboard, 0.142" thick, and separates the fuze in the upper end of the container and the booster in the lower end of the container. Secured to the inside of the cover tube and in contact with the end plate is a disk of plywood called the support. A central hole in the support is 5/8" in diameter at the top and 1-1/2" in diameter at the bottom. The smaller end of the hole is located just below the center bulge of the end plate, and the nose of the fuze is inserted in the hole in the support.

(3) Marking of container.— Embossed circumferentially on the cover end plate is the nomenclature of the container - "CONTAINER, M106." Stenciled in white letters and figures 1/4" high are the lot number, the packer's initials, and the month and year of packing.

(4) Sealing strip for container. A strip of black adhesive tape, 2" x 25-1/2", is used to seal the joint between the cover and the body of the container. In addition, the strip is lettered to assist in the identification of the container. On the sealing strip for the M106 fiber container, the nomenclature of the contents (see fig. 42), their lot numbers, the packer's initials, and the month and year of packing appear in white letters and figures 1/4" high.

FUZE, ROCKET, P.D.M4.  
LOT 00000-00  
WITH  
AUXILIARY BOOSTER, M1.  
LOT 00000-00 PACKER, M1. 000-19000

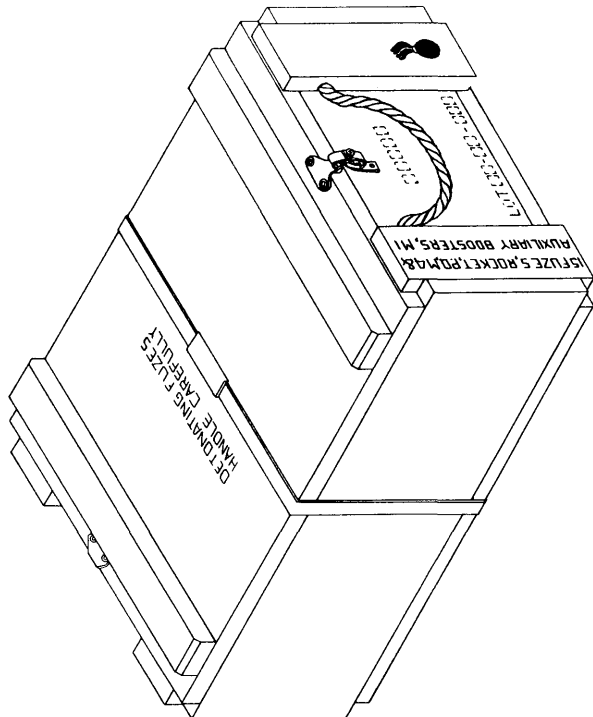
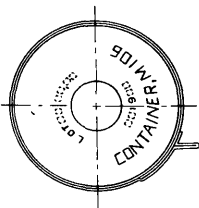
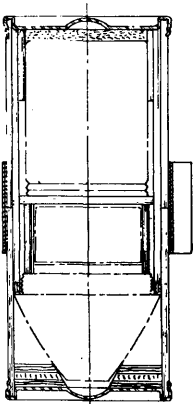
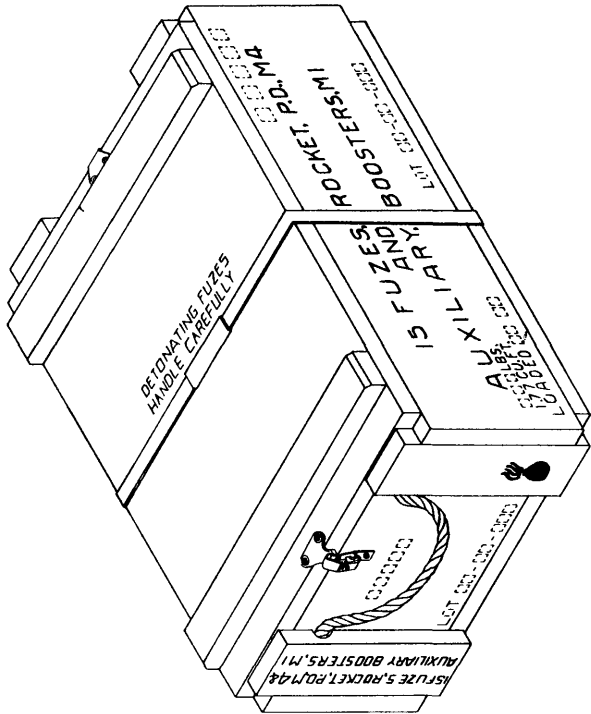

FIGURE 42. - PACKING OF FUZE, P.D., M4

(5) Packing box.— Into the wooden packing box are loaded 15 fiber containers in vertical position. The box is sturdily constructed of heavy lumber, reinforced by end and top cleats. As in all boxes containing fuzes, the nails in this box are cement coated. Between each set of end cleats, a length of jute rope is fastened to facilitate the handling of the box. The box is 22-3/16" x 12-11/16" x 9-7/8", and the cover is closed by means of toggles. Complete with contents, the box weighs 72.45 lb. The wooden exterior surfaces of the box are stained a light brown, and all hardware is coated with a lusterless light-brown enamel. Stenciled on the box in white is all the information shown in figure 42.

n. Action.— (1) The first step in the action is the adjustment of the setting pin to provide for superquick or delay action. This is accomplished by rotating the setting pin 180° to match up the red ball with the desired red arrowhead marked "SQ" or "DELAY."

(2) The cotter pin and ring are removed by pulling. When the cotter pin is withdrawn, the pin is free to move rearward and is held in its forward position only by the action of the set-back spring.

(3) When the rocket is fired, acceleration causes the set-back pin to move to the rear. The spring offers sufficient resistance to the rearward motion of the pin so that the pin reaches its most rearward position only after the rocket has cleared the launcher. In this feature lies the bore safety of the fuze.

(4) Upon the completion of the rearward movement of the set-back pin, the escape ball (which is made of steel and is 0.187" in diameter) rolls rearward in the ball escape hole, permitting the delay arming pin to be moved forward by the tension of the arming-pin spring. The arming pin moves forward only when the forward acceleration of the rocket has been completed.

(5) When the lower end of the delay arming pin clears the inner end of the slider, the slider is moved by the tension of the slider spring.

(6) The lock pin rides in the slider keyway and springs up into the lock-pin recess under tension of the lock-pin spring. The slider is thus locked into a position where the detonator is in line with the booster closing cup below and the body flash hole above. The fuze is now armed.

(7) On impact, the head of the fuze is crushed. The firing-pin assembly is driven to the rear, shearing the shear wire and initiating both primers. It is important to note that, no matter what action of the fuze is provided, both the instantaneous and delay elements are exploded.

(a) If the fuze has been set for instantaneous (SQ), both primers function. The relay charge is initiated, and its flame is transmitted down the instantaneous flash hole, through the parallel leg of the  in the setting pin, and through the body flash hole, where it initiates the M17 detonator in the slider-detonator recess. This travel of the flame is, to all intents and purposes, instantaneous. While this process occurs, the delay element has been functioning, and in the event that a malfunction occurs in the instantaneous element, the M17 detonator will function 0.1 sec. later.

(b) If the fuze has been set for delay action, both primers function as in (a) above, but, since the setting pin has been rotated 180°, there is no way to transmit the relay flame through the setting pin. The flame from the primer in the delay element passes through the compression chamber and the delay-element plug, causing the delay charge to begin to burn. This charge burns for 0.1 sec. and then ignites the delay charge, which detonates. The detonating wave and the flame from

this explosion pass through the hole in the setting pin and initiate the M17 detonator.

(8) Initiation of the M17 detonator causes detonation of the booster-closing-cup charge.

(9) The detonation of the booster-closing-cup charge detonates the booster charge, and the function of the fuze is completed.

o. Safety measure.—An acceleration of 100 gravities (1 gravity in terms of acceleration is 32 ft./sec./sec.; 100 gravities = 3,200 ft./sec./sec.) of short duration must be attained in the flight of the rocket to initiate arming of the fuze. Forward acceleration of the rocket has ceased at a point approximately 85' from the launcher, and at this point the fuze is armed and the rocket is ready to detonate upon impact.

### 68 SHELL ASSEMBLY

a. Component parts.—The shell assembly (see fig. 45) consists of the shell, burster tube, shell adapter, set-screw, fuze well cup, and shell plug. In the following subparagraphs these components will be described.

(1) Shell.—The shell is either forged or made from tubing in the shape of a flat-based cup, curved in slightly

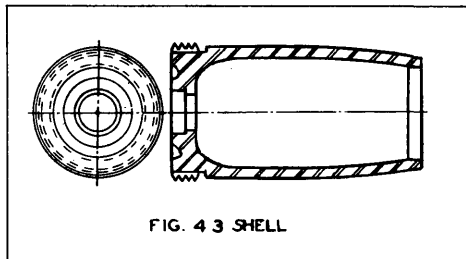

at the top and centrally drilled and countersunk in the base. It is 7.5" high and 4.5" in diameter at the base and has a wall thickness of 0.2". The forward opening is 3.375" in diameter. At a point 4.75" from the base, the walls curve inward toward the forward open-

ing on an 8" radius. The base is 0.52" thick, and a central hole 1.5" in diameter is drilled and countersunk to a diameter of 1.74". The walls thicken at an angle of 15° from the base to a point 1.250" above. This makes the interior surface of the shell entirely smooth and adds support to the base of the shell casing. The lower 0.81" of the outer walls is threaded to fit the rocket body. Above the threads is an unthreaded portion, 0.15" wide. In the face of the base is an annular groove whose diameter is 3.00". The groove is approximately 0.20" in width and depth.

(2) Burster tube.—The burster tube is steel tubing, 15-1/2" long and 1-3/4" in external diameter, with a wall thickness of 0.120". The bottom of the tube is smoothly rounded. The burster tube fits snugly and is brazed in place in the countersunk lower central shell hole.

(3) Shell adapter.—The adapter is a malleable-iron ring of a size to fit halfway into the shell nose. The upper outer surface of the adapter is curved to follow the contour of the shell body. The inner surface of the adapter is threaded to seat the fuze. In the wall of the adapter is a threaded hole, 0.25"

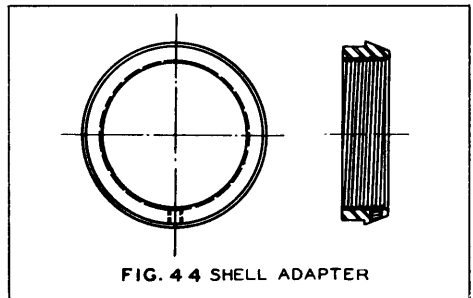

in diameter, that seats the setscrew. The adapter is fitted into the nose opening of the shell and welded into place.

(4) Setscrew.—This is a simple commercial setscrew, slotted at one end, that locks the fuze when the latter is inserted in the adapter.

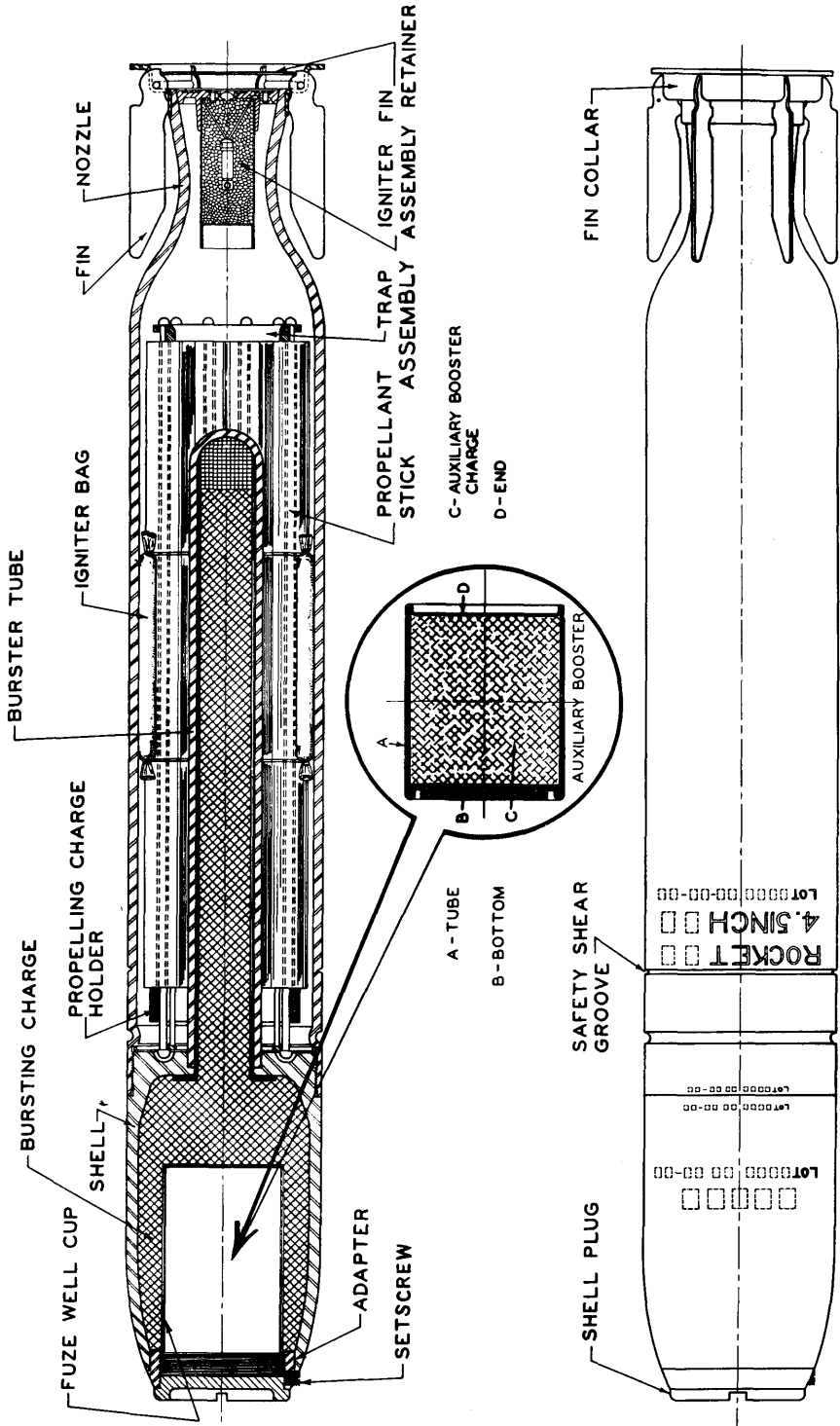

FIGURE 45. - ROCKET, H.E., 4.5", M8



(5) Fuze well cup.— This cup is made of thin steel (0.012" thick) in the shape of a cylinder. It is 2.83" in diameter, 4.67" deep, and is rimmed with a single thread at the open end. The single thread screws into the threading of the adapter and holds the cup in place.

(6) Shell plug.— This plug is made of cast iron, plastic, or sheet metal. It is rimmed, slotted on the upper face, and threaded beneath the rim

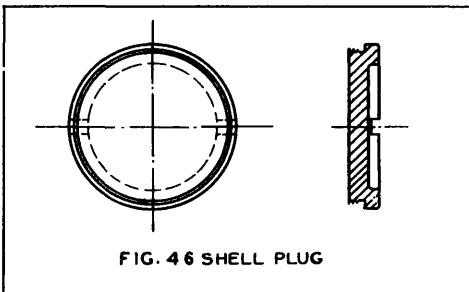

FIG. 46 SHELL PLUG

to fit into the adapter. After the fuze well cup is inserted, and prior to shipment, the shell plug is inserted; it is removed only to insert the fuze.

b. Painting and marking.

(1) Painting.— After the explosive is loaded into the shell, all external surfaces of the assembly, except the lower shell threads, are coated with lusterless olive-drab paint.

(2) Marking.— Circumferentially about the shell and 5" below the shell plug, the lot number of the shell, the loader's initials or symbol, and the month and year of loading are stenciled in yellow 1/4" letters and figures.

69 BODY ASSEMBLY

a. The body is a tube 23.29" long and 4.5" in diameter through approximately four-fifths of its length. The body is open at its forward end and is formed into a nozzle in the last one-fifth of its length. The central section of the body has no design peculiarities, but both ends deserve description.

b. The forward end is as follows: At a point, 0.187" from the inner edge of the rim, is a series of internal threads that fit the body to the shell assembly. In the rear of the threads is an external groove and an internal bulge, the groove being approximately 1/2" deep. The internal bulge acts as a rest to hold the trap assembly in place. Two inches to the rear of the external groove is a second external groove, approximately 0.06" deep. This second groove is a safety device, for the body will shear at this point if excessive propellant pressures develop.

c. The rear end of the body, or the nozzle, is as follows: The nozzle begins at a point 5.721" from the rear face of the body. It is formed by an initial inward curve on a radius of 3/4", followed by an outward curve on a radius of 1-3/4". The two curves form a venturi. The outer end of the second curve flattens out at an angle of 15° from the longitudinal axis of the body. The throat of the venturi is 1.828" in diameter, and the rear face is 2.62" in diameter. The last internal 3-7/8" of the nozzle are given a machine finish

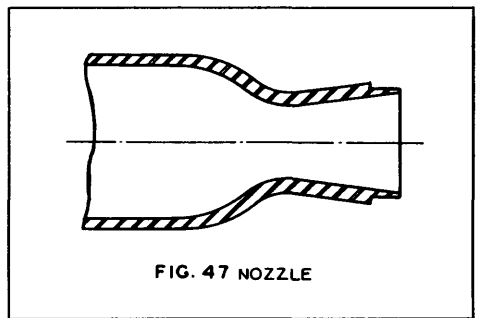

FIG. 47 NOZZLE

of the finest quality. The outer edge of the nozzle seats the fin assembly. Extreme care is taken to keep the nozzle concentric with the central section of the body, for a lack of concentricity will cause a thrust of escaping gas that is not along the longitudinal axis of the body. Such a thrust would result in inaccuracy in the flight of the rocket.

## 70 TRAP ASSEMBLY

a. General.— The trap assembly is a wire cage housed in the rocket body and providing a framework to hold the propellant in the proper position.

b. Components.— The trap assembly consists of a trap ring, 10 trap wires, and a trap plate.

(1) Trap ring.— The trap ring has the shape illustrated in figure 48. It is made of steel, is rimmed, and has a 3.47" diameter across the rim and a

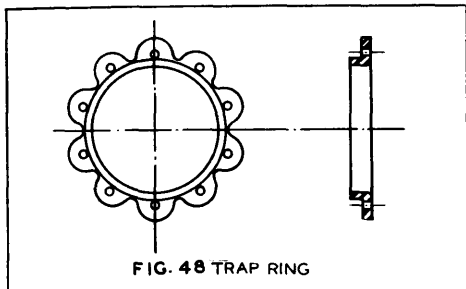

FIG. 48 TRAP RING

central diameter of 2.47". The trap wires are run through the 10 equally spaced 0.16"-diameter holes.

(2) Trap wires.— Each of the 10 trap wires is identical. Each is a bright basic-steel wire, 0.162" in diameter, with a small head on each end. Each head is 0.19" long. The wire from the base of one head to the base of the other is 16.88" long. One head is formed prior to insertion of the wire in the trap ring. The second is formed after insertion in the ring.

(3) Trap plate.— This component (see fig. 49) is 4.24" in diameter

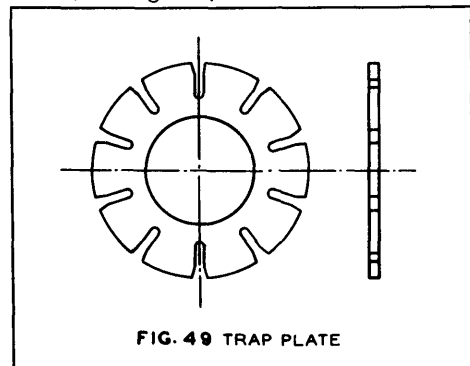

FIG. 49 TRAP PLATE

and 0.20" thick, with a central hole 2-1/8" in diameter. Radially about the plate are 10 equally spaced slots, each 0.164" wide and approximately 0.62" deep. Into these slots the trap wires are fitted, remaining there by reason of their tension.

c. Assembly.— Before the shell assembly is screwed into the body the trap assembly is slipped, trap-ring end first, into the threaded end of the rocket body until the trap plate comes to rest on the internal bulge of the body. Screwing the shell assembly into the body forces the trap plate against the bulge and holds the trap assembly in place. The trap wire heads extending above the surface of the trap plate fit into the annular groove in the base of the shell.

## 71 FIN ASSEMBLY

a. General.— The fin assembly for the M8 rocket is a unique arrangement that opens and guides the rocket in flight only after the rocket has cleared the launcher. The fins of the assembly are held in place by a component that is expelled by the blast of the escaping gas. The fins continue to be held in place by the walls of the launcher, and, after clearing the bore, snap to their outstretched position.

b. Components.— The fin assembly consists of a fin collar, six fins, a fin retaining ring, and a fin retainer.

(1) Fin collar.— This collar, 0.094" thick and made of cadmium- or zinc-plated steel, fits into the notched

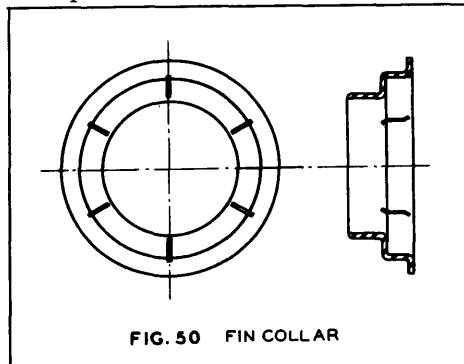

FIG. 50 FIN COLLAR

outer edge of the nozzle. The section of the collar that fits over the nozzle notch is 2.630" in diameter and 0.706" deep. The collar then widens abruptly to a diameter of 3.500". Above the ledge thus formed are collar walls 0.562" high. A rim, 4.25" in diameter, extends outward from the top of these walls. Six equally spaced slots, 0.085" wide, are cut from the ledge and wall in the upper section of the collar. Into these six slots the holed ends of the six fins are fitted. When the fins are in their retained position, they rest against the external portion of the collar wall that fits over the nozzle notch. In their flight position, they are forced back against the rim of the collar.

(2) Fins.— There are six fins in the fin assembly, all identical, all made of zinc- or cadmium-plated steel, and all having the shape illustrated in figure 51. The fin is 4-1/8" long and 0.078"

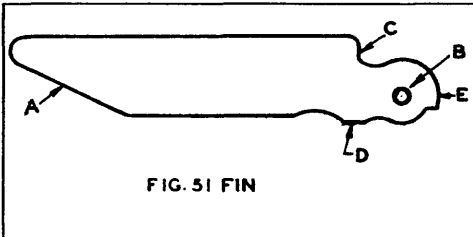

FIG. 51 FIN

thick and has a maximum width of 13/16". When the fin is in the retained position, the sloped end A rests against the outer wall of the nozzle, the flat surface D rests on the lower outer wall of the fin collar, and the fin retaining ring passes through the hole B. In the flight position, the fin has rotated 90° and the notch C fits against the upper rim of the collar. The end E of each fin is fitted through a slot in the fin collar and is held in place by the fin retaining ring.

(3) Fin retaining ring.— The fin retaining ring is a length of 0.135" steel wire bent into a circle 3-1/2" in diameter. The ring is not completely closed, a 1/2" arc remaining open. The ring is run through the hole in each fin

after the fins have been fitted into the fin collar slots. The ring is then welded in six places to the internal ridge of the fin collar.

(4) Fin retainer.— This component is a thin cadmium- or zinc-plated steel washer having a maximum radius of 1-11/16". The central hole of the washer is 2-1/4" in diameter. The fin retainer has the shape illustrated in figure 52. There are six points A on

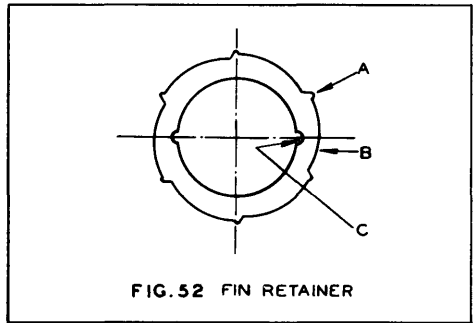

FIG. 52 FIN RETAINER

the perimeter of the retainer. Between each two points is a cam surface B. The fin retainer is inserted in the rear end of the fin collar, with the fins in their retained position. The points are placed next to the edges of the fins, and the retainer is rotated by engaging the notch C. This rotation cams the upper ends of the fins outward, locking them into position. They remain in this position until the retainer is expelled by the blast of the propellant gases and the rocket clears the bore of the projector.

## 72 IGNITER ASSEMBLY

a. General.— The igniter assembly consists of an open fiber tube fitted into a plastic base. The base houses a primer for percussion ignition of the igniter and a ring that provides electrical contact for electrical ignition of the igniter. Either method of ignition can be used. The igniter fits into the open end of the nozzle, where it is secured with cement. When the igniter is initiated, it ignites the propellant, the gases of the latter blowing the igniter from the nozzle.

b. Components.— The igniter assembly consists of the tube, closing cup, squib assembly, primer, primer-holder assembly, cup, contact-ring assembly, and igniter charge.

(1) Tube.— The tube is a cartridge-paper cylinder, 3.54" long and 1.25" in diameter. Stenciled lengthwise in black letters and figures on the tube (keeping 7/8" at one end unlettered) are the name and use of the assembly.

(2) Closing cup.— This component is a glazed paperboard cup 9/16" deep and approximately 1.16" in diameter. The diameter is controlled by the necessity for a snug fit between the closing cup and tube.

(3) Squib assembly.— The squib is an electrical arrangement for igniting the charge and has two terminals attached to the lead wires.

(4) Primer.— The primer is a No. 28 cal..50 primer (see vol. 1).

(5) Primer-holder assembly. The primer holder is a steel cup with a wide rim. It is 0.24" deep and 0.3" in diameter. The rim is 0.8" in diameter. Equally spaced about the undersurface of the rim are welded three studs, normal to the rim. The studs are each 0.19" long and 0.09" thick.

(6) Cup.— The plastic cup seats all the other components of the igniter assembly, and the rim of the cup is cemented to the nozzle. The cup is shaped as illustrated in figure 53. The central hole seats the primer holder assembly; the shallow annular groove seats the contact ring. The sleeve is slotted at one point to permit the terminal of one lead wire to be engaged in one of the contact-ring studs. The rim of the cup is chamfered to allow a close fit in the nozzle. In the base of the cup are six holes, each 0.006" in diameter and spaced as shown in figure 53. The studs fit through these holes.

(7) Contact-ring assembly.— The contact ring is made of steel and is 2.128" in diameter with a central hole 1.3" in diameter. To one face of the ring are welded three studs similar to those welded to the undersurface of the primer holder. These studs are placed so that they will fit into the outer set of holes in the cup.

(8) Igniter charge.— The igniter charge consists of 648 grains of grade A-1 black powder.

c. Assembly.— The primer-holder assembly is fitted into the central cup hole so that the studs slip through the inner set of holes in the cup. The

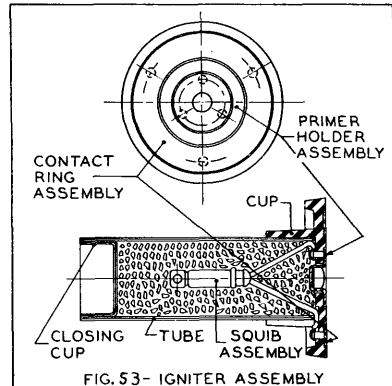

contact-ring assembly is fitted into the annular groove of the cup so that the studs slip through the outer set of holes in the cup. One terminal is engaged on one of the contact-ring studs; the second terminal of the squib assembly is engaged on one of the primer-holder studs. All studs are then riveted so that all parts are up tight. The squib is held upright by the stiffness of the lead wires. The tube is slipped into the sleeve of the cup and secured with cement. The opening between cup and tube, where the terminal and lead wires exit, is securely sealed with cement. The igniter charge is poured into the tube, and the closing cup, its outer wall coated with cement, is pressed into place against the charge. The No. 28 primer is seated, and the annular

groove between primer and primer holder is sealed with red N.R.C. compound.

### **73 PROPELLANT**

a. The propellant for the M8 rocket consists of 30 sticks of ballistite which is a double-base propellant powder. Each stick is 5" long and 7/8" in diameter and has an axial hole 1/4" in diameter. Three sticks are on each trap wire, and there is sufficient clearance between stick and wire to allow the burning of the inner stick wall simultaneously with the burning of the outer wall. The three sticks which run onto each trap wire do not occupy all the length of the wire. Motion is prevented by an adhesive strip, the propelling-charge holder, 1" x 30", that is bound about the wires of the trap assembly with one edge against the sticks.

b. Two igniter-bag assemblies are bound on two opposite columns of propellant. The bags assist the ignition of the propellant by catching the flame of the igniter and igniting themselves. This ignites the upper propellant sticks which otherwise might fail to ignite immediately. The igniter-bag assembly consists of an igniter-bag charge of 333 grains of grade A-1 black powder inclosed in a cotton bag sewn together from a 7-1/2" x 1-1/8" cloth. The ends of the bag are closed by 10" lengths of tying cord. This cord is also used to tie the bags to the propellant.

c. When the rocket is fired in a temperature range of 20° to 90° F., a full propellant charge is used. When the rocket is fired in a temperature range of 50° to 130° F., three sticks of propellant must be removed to avoid a dangerously excessive propellant pressure. This temperature overlap makes possible firings at the same range with either a full or a reduced charge. This is advantageous in instances when rockets are prepared for firing then are subjected to a change in temperature

before being fired. To remove the required amount of propellant, the shell assembly is unscrewed from the body. The body is then set upright on a sturdy, level, surface. Because of the presence of the black-powder igniter bags, the removal of the trap assembly must be undertaken with care. When the trap assembly has been removed, three equidistant trap wires are unsprung from the trap plate after the propelling-charge holder has been unwound. (Do not remove sticks from those wires that hold the igniter-bag assemblies.) Replace trap wires and reassemble the round.

### **74 EXPLOSIVE CHARGE**

a. The bursting charge for the M8 rocket is approximately 4.3 lb. of cast TNT. The charge is poured into the shell assembly, completely filling the burster tube. In the casting operation a fuze well is formed in the shell charge. This well is 2.88" in diameter and 4.38" deep.

b. To protect the bursting charge in the burster tube from the high temperatures generated by the propellant gases, an insulator tube is inserted and fire clay poured into the burster tube. The insulator tube, made of chipboard, is 15-3/16" long and 1.49" in diameter. The wall thickness is 0.08". After the inner and outer surfaces have been coated with acidproof black paint, the insulator tube is slipped into the burster tube, where it seats on the burster-tube bottom. The end of the insulator tube, extending above the burster tube, is pressed flat against the shell body. The fire clay is pressed into the burster-tube bottom to a depth of 1.28" under a pressure of 250 lb./sq.in.

### **75 PAINTING AND MARKING**

a. Following the loading of the explosive into the shell assembly, the lot number, loader's initials or symbol, and the year and month of loading of the shell assembly are stenciled in 1/4" letters and figures on the shell. This

lettering appears circumferentially, 5" below the nose of the shell.

b. Following assembly of shell and body, the nomenclature of the round and the lot number of the shell and body are stenciled on the body. They are stenciled in 1/2" letters and figures, and the letters and figures of the two lot numbers, etc., are 1/4" high. All of this stenciling appears circumferentially on the motor in such a position that the lower line of characters is 12" from the nose of the shell. The nomenclature reads as follows:

"ROCKET, H.E.,

4.5-INCH, M8"

c. All letters and figures are stenciled with yellow paint on the olive-drab lacquer enamel that covers all external surfaces of the rocket.

## 76 PACKING

a. General.— The complete round (except fuze), with nose plug, is packed in an individual fiber container. Three fiber containers (three rounds) are bolted together into a bundle. It is this bundle that personnel will see in the field, and they should be familiar with its appearance, weight, and dimensions.

b. Container, fiber, 4.5", M97. This is the individual fiber container in which the rocket is packed. It follows the general design for fiber containers. It has an inner and outer tube and a cover tube. It is painted black and is reinforced at the ends with steel end plates. However, it has no nose support, since the rockets contained are unfuzed. The container is 32-1/16" long and 5-5/16" in diameter and weighs 39.5 lb. when loaded. The end plates have a center bulge and are embossed semicircularly with the nomenclature of the container in 1/4" letters and figures. After the rocket is packed in the container, the loader's initials and the lot number are stenciled on the end plate with white marking ink.

c. Sealing strip.— A 2" x 38" strip of yellow adhesive tape is wrapped about the joint between cover and tube, sealing the joint and identifying the contents of the container as high explosive.

d. Bundle.— Three containers are placed, cover end up, in the lower clover-leaf end plate, and the bolt is run through the end plate and engaged in the upper end plate, where it is secured, assembling the bundle. The complete bundle is 33" long, 10" high, and 135 lb. in weight. The shipping and identification plates have stamped on them the information illustrated in figure 54.

e. Box.— For overseas shipment two rockets in M97 containers are packed in a wooden packing box. The box is 36" x 13-5/8" x 13-5/8" and weighs, complete with contents, 90 lb.

## 77 SAFETY PRECAUTIONS

Due care must be exercised in handling these rockets, because of their high-explosive content. It is important that the rocket be protected against the direct rays of the sun and that it never be stored at temperatures above the maximum at which it can be fired. When the rocket is fuzed, further care must be taken with its handling; with the safety pin removed, the fuze must be handled as though armed.

## 78 BALLISTICS

a. Range.— The maximum range of the M8 rocket assembled with the M4 fuze is 4,500 yd.

b. Muzzle velocity.— 900 ft/sec.

c. Dispersion.— Fifty percent of a given number of rounds fired at maximum range will fall within a rectangle whose dimensions are 65 yd. x 130 yd.

d. Pressure.— The motor pressure, at 90° F., is 3000 lb./sq.in. with the basic charge.

e. Miscellaneous.— To the M8 rocket body may be assembled a variety of heads, containing various chemical agents.

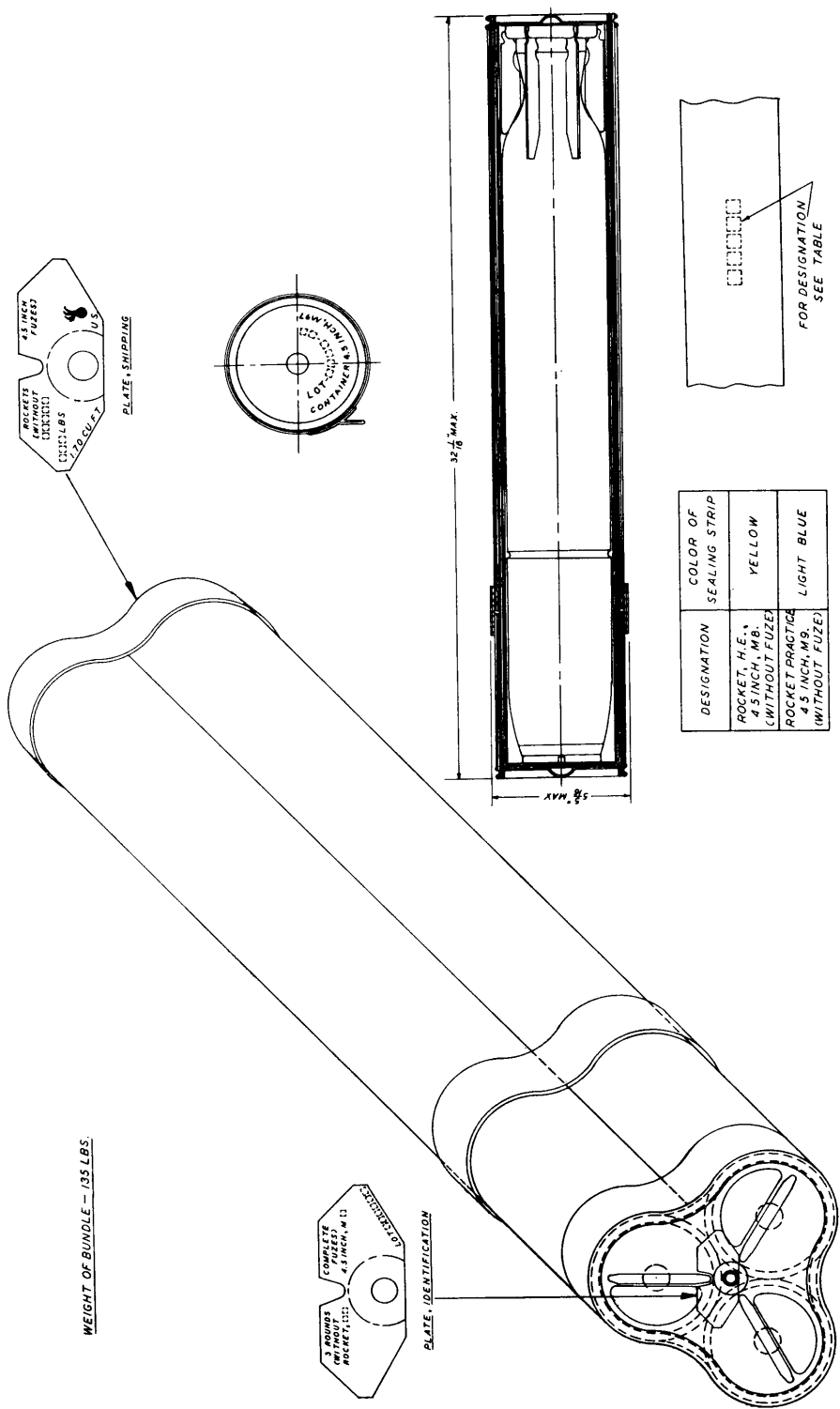

DESIGNATION	COLOR OF SEALING STRIP
ROCKET, H.E., 4.5 INCH, M8, (WITHOUT FUZE)	YELLOW
ROCKET PRACTICE 4.5 INCH, M9, (WITHOUT FUZE)	LIGHT BLUE

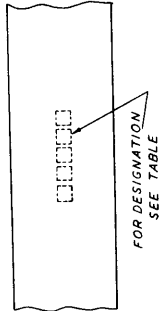

FIGURE 54. - PACKING OF THE M8 AND M9 ROCKETS

## SECTION II

## ROCKET, PRACTICE, 4.5", M9

## 79 GENERAL

a. Use.— The rocket, practice, 4.5", M9, is a companion round to the M8 high-explosive rocket. It has the same weight as the M8, is assembled with similar components, has the same ballistics, and lacks only the explosive charge and live fuze to be identical. Since it is similar in weight and has the same trajectory as the M8, it is used to give rocket crews training in handling and firing without the danger or expense incidental to the use of the M8 H.E. round. In addition, at short ranges, if the M9 is fired with the M4 fuze, the functioning of the fuze provides a suitable smoke puff for ranging purposes. At extreme ranges, the auxiliary booster may be assembled with the M4 fuze to provide a visible smoke puff. As an alternative, a bag of black powder placed below the M4 fuze will also produce a satisfactory smoke puff. The M9 rocket, then, is valuable both for drill purposes and for simulating fire.

b. The launcher.— The M9 practice rocket is fired from the same types of launchers as are employed to fire the M8 high-explosive rocket.

## 80 DESCRIPTION OF COMPONENTS

The M9 rocket is identical to the M8 H.E. rocket with the exception of a high-explosive charge and a live fuze. Substituted for these two components is an inert shell filler and a dummy fuze. Both of these components are described in the following subparagraphs.

a. Fuze, rocket, dummy, M6.

The M6 fuze is a solid gray-iron casting having the same general external appearance and the same weight as the M4 fuze (assembled with the M8 rocket). A hollow space is formed in the bottom of the fuze when material is removed to adjust the weight of the fuze. The external and internal surfaces of the fuze are coated with blue lacquer enamel, except the threads, which are lightly coated with shell grease. Stamped circumferentially about the fuze, 1/4" above the shoulder and in 1/8" letters and figures, is the nomenclature of the fuze, "FUZE, ROCKET, DUMMY, M6." The fuze is packed separately, but information concerning packing is not available.

b. Inert filler.— Approximately 4.5 lb. of a mixture of 60 percent plaster of paris and 40 percent zinc stearate is poured into the shell assembly. A fuze well is formed in the same manner as the fuze well in the M8 rocket and has the same dimensions.

## 81 PAINTING AND MARKING

a. Painting.— All external surfaces of the M9 rocket shell, except threads, are coated with light-blue lacquer enamel. Threads are lightly coated with shell grease. The body is coated with olive-drab lacquer enamel.

b. Marking.— In the same position as on the M8 appears the nomenclature of the round:

"ROCKET, PRACTICE,

4.5-INCH, M9"



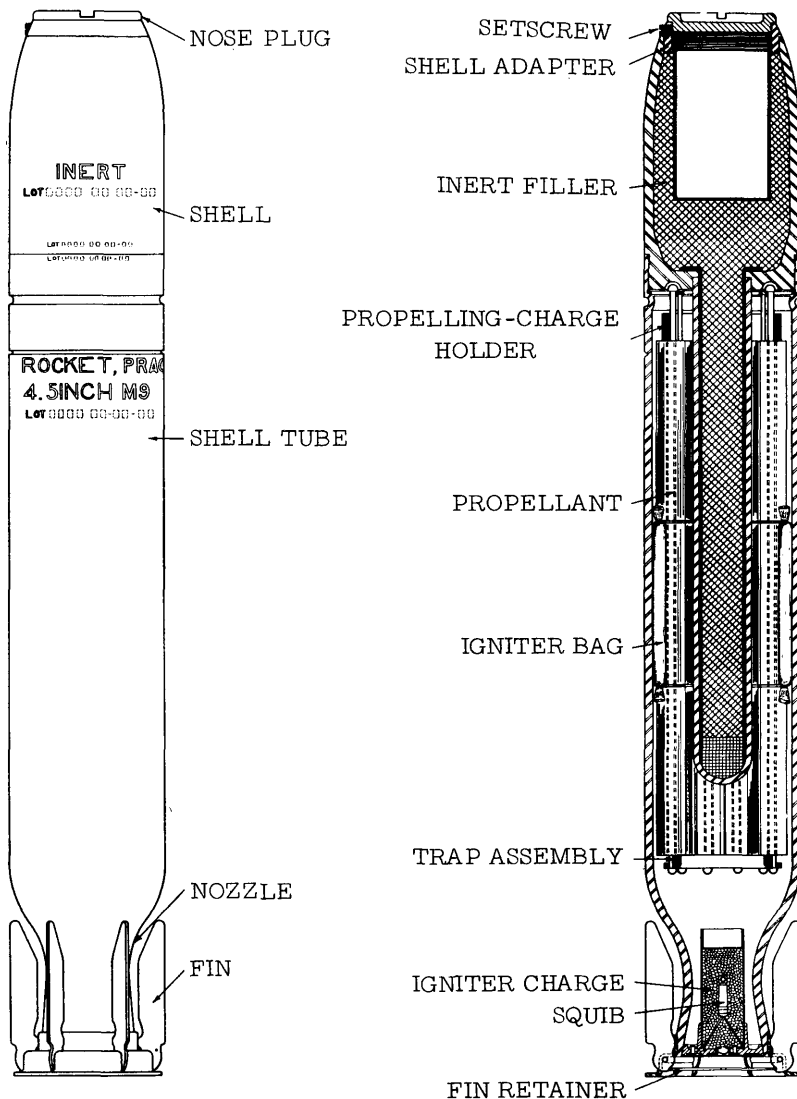

FIGURE 55. - ROCKET, PRACTICE, 4.5", M9

Below the nomenclature is the lot number of the round. All lettering is in white, the nomenclature in 1/2" letters and figures, the lot number, loader's initials or symbol, and the month and year of loading in 1/4" letters and figures. On the shell, 5" below the fuze opening, is stenciled in 1/2" white letters, the word "INERT," and immediately below this word, in

1/4" letters, is stenciled the lot number of the shell.

**82 PACKING**

Except for the sealing strip (which is light blue instead of yellow) and the appropriate change in nomenclature, the M8 and M9 rockets are packed identically. As with the M8 rocket, the M9 is shipped unfuzed and with a nose plug inserted.

## SECTION III

### 4.5" ROCKET DEVELOPMENT

#### 83 GENERAL

Although the principles of operation of the various component parts of the 4.5" rockets have been retained throughout the course of their development, minor changes in the design of some of the components have been made from time to time with a view to improving their functioning and the functioning of the complete assembly. A brief history of the development of these rockets is given below:

a. Production was begun in February 1943 on the design of shell (head) and body (motor) designated as the M8 and M9. During the course of manufacture and the ballistic acceptance tests of the metal parts, several weaknesses in design and materials were revealed. Many metal parts from different manufacturers failed in the ballistic test when all other specifications had been met. It was decided in the latter part of June 1943 to discontinue mass production and to place the item in the development stage.

b. All production contracts were canceled, and a contract for limited procurement was placed with the Revere Copper and Brass Co. for a lot of 390,000, which would complete the limited procurement of 550,000 originally authorized.

c. The design of the body (motor) was changed in July 1943 to provide for an increase in strength, particularly at the threaded end. An effort was made to use the existing shell (head), which had been manufactured for the M8 and M9, by machining new base threads. The round composed of the strengthened motor and the modified head was designated as the M8A1.

d. Tests on the M8A1 indicated that the base of the head was weak and, because of the large deflection under pressure, would not allow full advantage to be taken of the strength of the new motor. A new head was designed to overcome this difficulty. The round composed of this new head and the motor from the M8A1 was designated as the M8A2. The M8A1 round is now in production but will be superseded by the M8A2 as soon as the new head is in quantity production. The total procurement of the M8, M8A1, and M8A2 will be covered by the authorization mentioned in b.

e. The round composed of the M8A2 head and a high-strength motor is designated as the T22 rocket; the same head and motor with the head inert-loaded for the practice round is designated as the T46 rocket. This round is capable of withstanding working pressures considerably in excess of the working pressures of the previously mentioned rounds, and it provides for an increased powder charge and an increased factor of safety. The characteristics of the round are as follows:

Designation:

H.E. -----	T22
Practice -----	T46

Length, w/M4A2 fuze or

dummy fuze ----- 32"

Weight, each type ----- 38-3/4 lb.

High-explosive charge,

w/M4A2 fuze ----- 4.3 lb.

Propellant ----- 4.75 lb.

Velocity ----- 865 ft./sec.

Temperature range --- -20° to 125° F.

Maximum range (approx.) -- 4,200 yd.

## 4.5" ROCKET

Range, yd.	Standard charge (4.6 lb.) for normal temperature		Low charge (4.2 lb.) for high temperature	
	At 70° F.		At 100° F.	
	Elevation, mils	Area of impact, yd.	Elevation, mils	Area of impact, yd.
500	39		46	125 x 200
750	58		69	
1,000	80		94	
1,200	98		116	
1,400	116		140	
1,600	136		167	
1,800	157		193	
2,000	180		222	
2,200	204		253	
2,400	228		287	
2,600	256	250 x 400	325	
2,800	286		369	
3,000	318			
3,200	356			
3,400	365			
3,600				
3,800				
4,000	550			

FIGURE 56. - FIRING TABLE FOR THE M8 AND M9 ROCKETS

### 84 FIRING TABLE

The firing table shown in figure 56 is derived from data computed by firing the rockets from a fixed proving-ground launcher. For this reason the table may not be completely accurate for rockets fired from mobile mounts (see section V). In any event, the data compiled in the firing table is reasonably accurate and will serve its purpose until superseded. Firing tables for all launchers will be made available when the launchers are issued.

### 85 TEMPERATURE RANGES

The 4.5" rockets, M8 and M9, may be fired within temperature ranges of 20° to 120° F. The full charge may be fired within a temperature range of 20° to 90° F., and the reduced charge may be fired in a temperature range of 50° to 120° F. Figure 57 shows the re-

lation between the full and reduced charges for the low and high temperature ranges. A temperature of 20° F. for the full charge gives a pressure

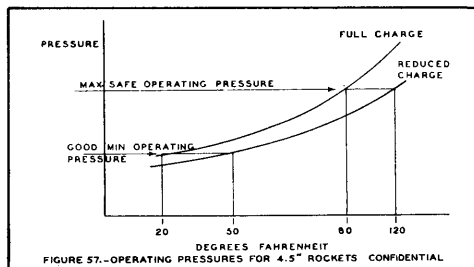

which corresponds to that obtained by the reduced charge at 50° F. This is a good minimum operating pressure. In addition to a minimum operating pressure, there is a safe maximum. This maximum pressure is produced by the reduced charge at 120° F. Thus, the reduced charge is necessary between

the temperatures of 90° and 120° F. in order to remain within the safe operating pressure. Below 50° F. the reduced charge will give pressures below the minimum operating value. Between 50° and 90° F., either charge will work satisfactorily. However, the full charge

will give a greater range than the reduced charge as indicated by the firing table given in figure 56. The overlap in temperature range gives a versatility in charges that is valuable tactically and provides a wide margin of safety in relation to operating pressures.

## SECTION IV

### ROCKET, FRAGMENTATION, 4.5", T29

#### 86 GENERAL

The T29 rocket (see fig. 58) consists of a 20-lb. fragmentation bomb, M40, assembled to the M8 4.5" rocket

motor. The assembly is made possible by a special adapter. The M111A2 bomb fuze is used with the T29 at the present time.

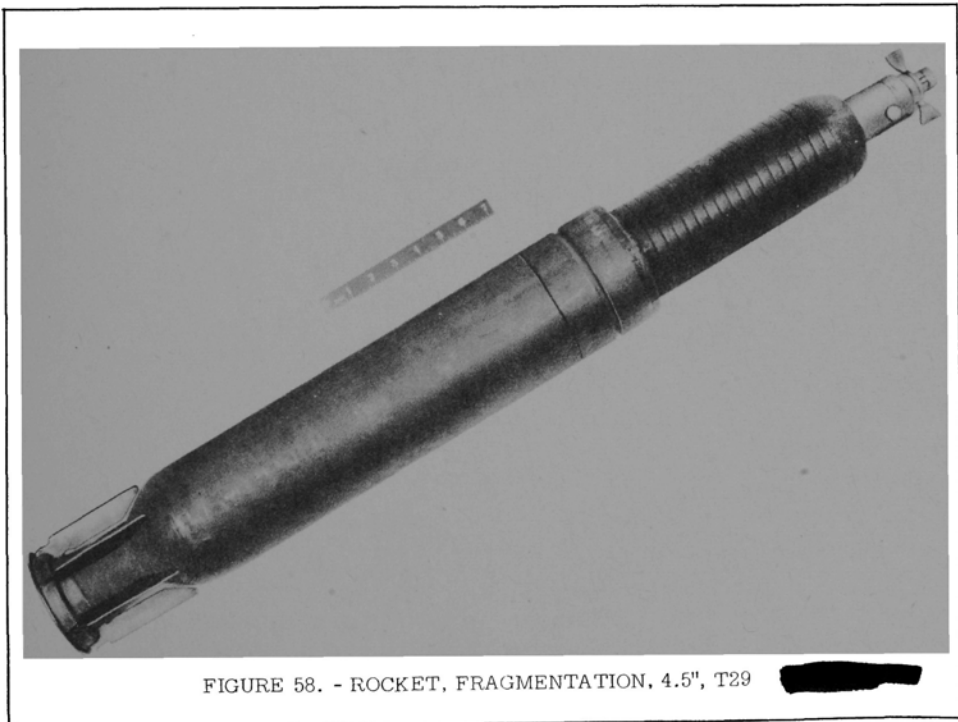

FIGURE 58. - ROCKET, FRAGMENTATION, 4.5", T29

# NOTES



## SECTION V

## 4.5" ROCKET FUZE DEVELOPMENT

**87 GENERAL**

The M4 P.D. rocket fuze assembled with the M8 rocket has undergone change since its standardization. Two successive major changes resulted in the M4A1 and the M4A2 fuzes. These changes and the modified fuzes are discussed in the following paragraphs.

**88 FUZE, P.D., M4A1**

a. The principal changes in the M4 fuze (see fig. 37) to produce the M4A1 fuze are as follows:

(1) A different delay time has been provided. Approximately 40 percent of the present production of M4A1 fuzes retain the .1-sec. delay found in the M4 fuze. Such fuzes are for ground use only. The remaining production quantities of the M4A1 fuze have a .015-sec. delay. This delay was requested by the Army Air Forces, and fuzes having this delay are for air use only. The short-delay charge consists of approximately .136 grain of Army black powder, grade A-5, compressed at a pressure of 60,000 lb./sq.in. The .1-sec. delay charge consists of 1.23 grains of a similar powder pressed under a similar pressure. The dimensions of the delay-element housing depend on the type of delay charge used. When the delay charge is inserted in the small central cavity, the long narrow hole below the compression chamber is 1.520" long; when the short-delay charge is inserted, the hole is .355" long. The difference in length of this hole is obtained by increasing the length of the compression chamber. The different delay times will be included as part of the nomenclature of the fuze and will appear stamped on the fuze. Requests for the fuze should specify the delay time required.

(2) The walls of the fuze have been made thinner so as to reduce the total weight of the fuze.

(3) With the use of the two-zone propellant in the modified M8 rocket, it was found necessary to reduce the spring tension so that a lower acceleration would arm the fuze. The M4 fuze required 160 G. to arm (in later production models this requirement was reduced to 100 G.); the M4A1 requires 100 G. to arm.

b. Upon completion of the present production program for the M4A1 fuze, it is contemplated that the fuze will be declared limited standard. Production of the M4A2 will begin on a large scale, and issues of the M4A1 will be made until stocks are exhausted.

**89 FUZE, P.D., M4A2**

The M4A2 rocket fuze (see fig. 60) differs from the M4 and M4A1 in the following respects:

a. The body has been redesigned to seat a new type of setting pin. In the M4 and M4A1 fuzes when the setting pin was not rotated completely through 180°, the flash holes in the setting pin were not aligned with the body flash hole and the delay and instantaneous flash holes; the setting pin presented a solid metal surface to the flame from either the superquick or delay elements, and the fuze would not function completely. When this condition existed, the rocket became a dud. To obviate this difficulty, the arrangement illustrated in figure 60 was devised. An oblique hole, 5/32" in diameter, is drilled from the upper rim of the delay-armpin hole to the body flash hole. Into this

hole, at a 25° angle, is fitted the delay element. The flash from the delay element is thus certain to pass unobstructed through the body flash hole and set off the slider detonator no matter whether the setting pin is set correctly or not.

b. The new setting pin is 1.33" long and has a single diagonal flash hole passing through the unslotted end. This flash hole is .218" in diameter and is set at angle of 28°.

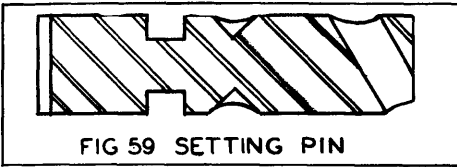

c. The slider for the M4A2 fuze is made of aluminum, affecting a considerable reduction in weight. At the same time, the locking pin has been strengthened (see fig. 60). The combination of these two changes has done much to prevent malfunctions of the fuze during ricochet. In the M4 and M4A1 fuzes, the heavy slider occasionally sheared the weaker locking pin and slid back into the unarmed position. Such a malfunction is unlikely to occur now.

d. Another change is the use of a lead-brass forged body as a third alternative. This is in addition to the malleable-iron and gray-iron castings previously specified.



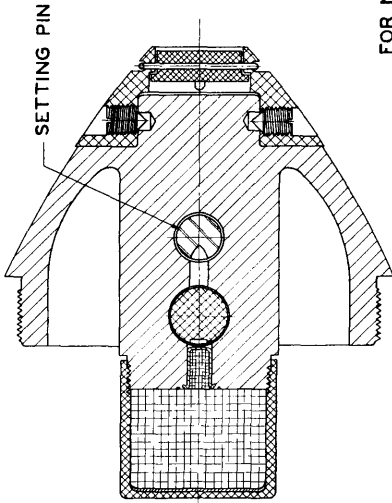
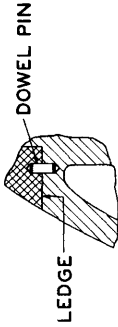
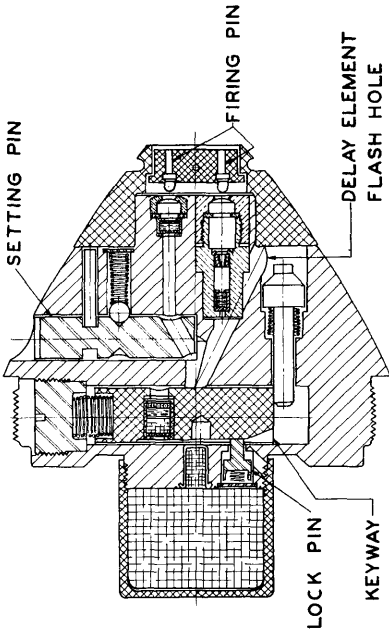
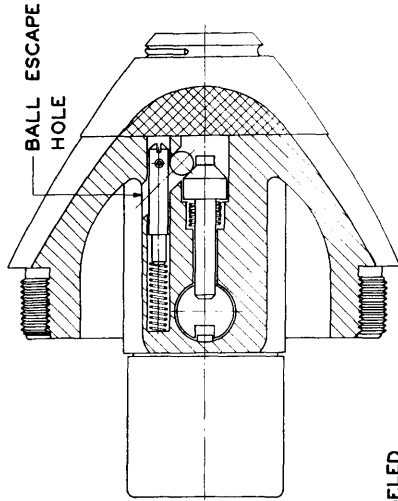
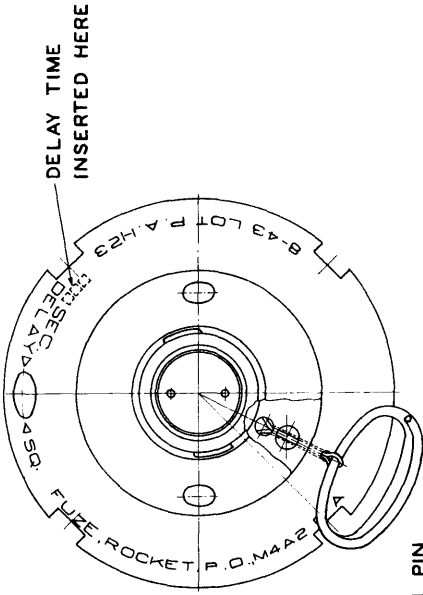

FOR NOMENCLATURE NOT LABELED  
REFER TO FIG. 37

FIGURE 60. - FUZE, P.D., M4A2

SECTION VI

4.5' ROCKET LAUNCHERS

90 GENERAL

a. Launchers for rockets, 4.5" and larger, are of three general classifications.

(1) Air-to-ground or air-to-air launchers are mounted on aircraft and are used to launch rockets at ground targets or at other aircraft.

(2) Ground-to-ground launchers are mounted on vehicles or emplaced on the ground and are used to launch rockets at ground targets.

(3) Antiaircraft launchers are mounted on vehicles or emplaced on the ground and are used to launch rockets at aircraft. They are not used by the United States Army.

b. There are three types of ground-to-ground launchers.

91 LAUNCHER, ROCKET, MULTIPLE ARTILLERY, 4.5', T27 AND T27E1

a. Description.- The T27 launcher (see figs. 61 and 62), designed to provide a light and highly mobile weapon of great fire power for ground-to-ground use, is an eight-tube launcher. It may be mounted on a 1-1/2-ton truck or assembled for ground fire at a selected position. This weapon is in the development stage. A second pilot, which will be designated T27E1, is being designed for breakdown into two-man loads not exceeding 120 lb. each.

b. Principal characteristics.

No. of tubes ----- 8

Elevation ----- -5° to +45°

Traversal ----- Provided by turning truck, or by shifting trail in ground fire.

Firing mechanism-Electric, permitting single-round or ripple fire.

Blast protection for crew ----- None

Sighting equipment ----- For indirect fire only.

Weight -----

c. Ripple fire.- Ripple fire refers to the setting of the firing mechanism that permits the rockets to be launched one after another at short intervals.

92 LAUNCHER, ROCKET, MULTIPLE ARTILLERY, 4.5', T34

a. Description.- This ground-to-ground launcher (see fig. 63), now under development, will be mounted on the turret of an M4 medium tank. It is of the expendable type, composed of 60 opaque plastic tubes which may be jettisoned at will. The rockets are fired electrically, either singly or in ripple fire. Elevation is from -5° to +30° by means of the elevating mechanism of the gun in the turret. Traversal is accomplished by movement of the turret. All 4.5" ground-to-ground rockets may be used in this launcher. The launcher weighs approximately 1,800 lb.

b. Principal characteristics.

No. of tubes ----- 60

Elevation ----- -5° to +30°

Traversal ----- Provided by rotating turret.

Firing mechanism-Electric, permitting single-round or ripple fire.

T36  
LAUNCHER

~~Blast protection~~ ----- Tank itself.

Sighting equipment ---Tank equipment.

Weight (approx.) ----- 1,800 lb.

**93 LAUNCHER, ROCKET, MULTIPLE  
ARTILLERY, 4.5", T36**

a. Description.-- This is a ground-to-ground launcher with eight light steel tubes. It can be fired from the ground or installed on a 1/4-ton 4 x 4 truck. Firing is electrical, in single rounds or in ripple fire. Elevation is from -5° to +35°. When mounted in the 1/4-ton truck, the launcher is traversed by movement of the vehicle. When the launcher is used as a ground weapon, it can be traversed through 20°. This launcher is under development.

b. Principal characteristics.

No. of tubes ----- 8

Elevation ----- -5° to +45°

Traverse:

Truck-mounted - Provided by turning truck.

Ground-emplaced ----- 20°

Firing mechanism- Electric, permitting single-round or ripple fire.

Blast protection -----

Sighting equipment -----

Weight -----

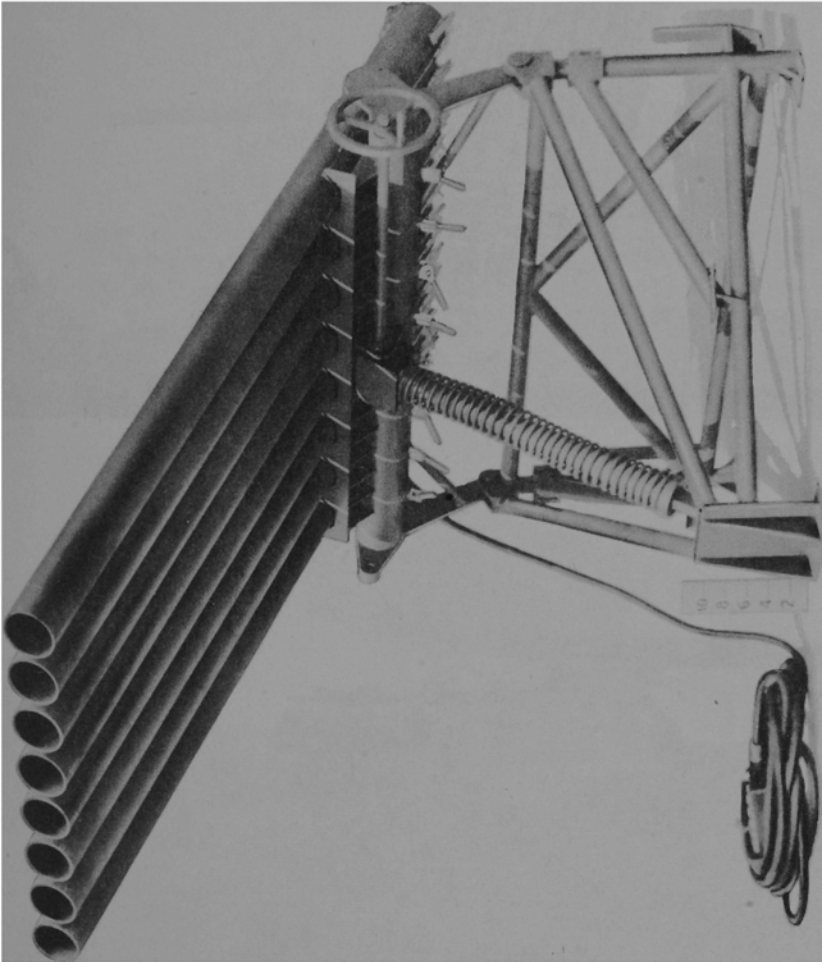

FIGURE 61. - T27 LAUNCHER, LEFT FRONT

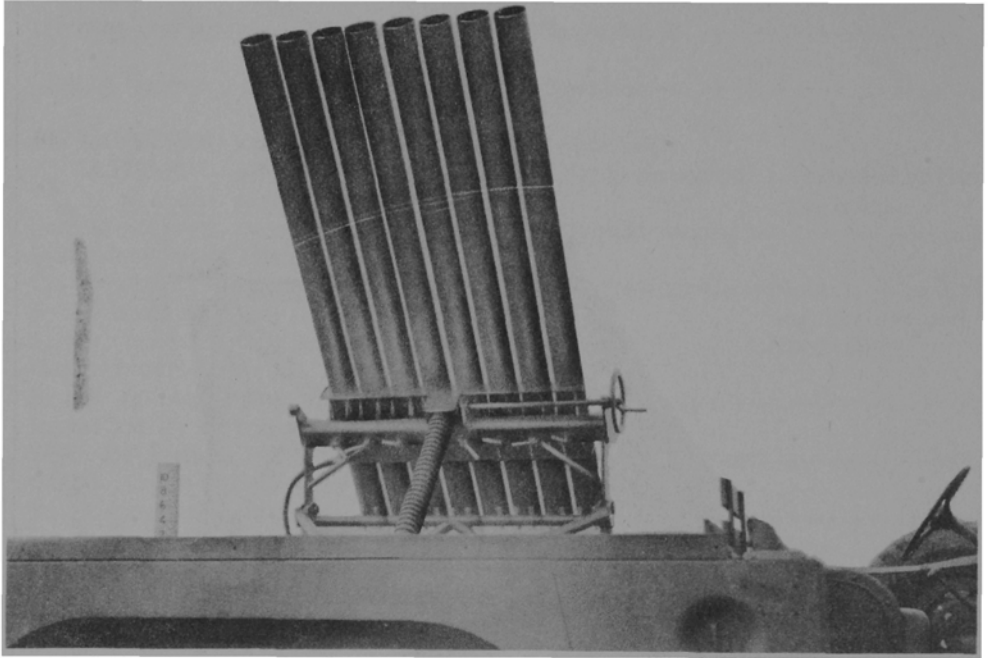

FIGURE 62. - T27 LAUNCHER MOUNTED ON 1-1/2-TON 6 X 6 PERSONNEL,  
CARRIER. TOP: FRONT, 45° ELEVATION. BOTTOM: THREE-QUARTER  
LEFT FRONT, -5° DEPRESSION

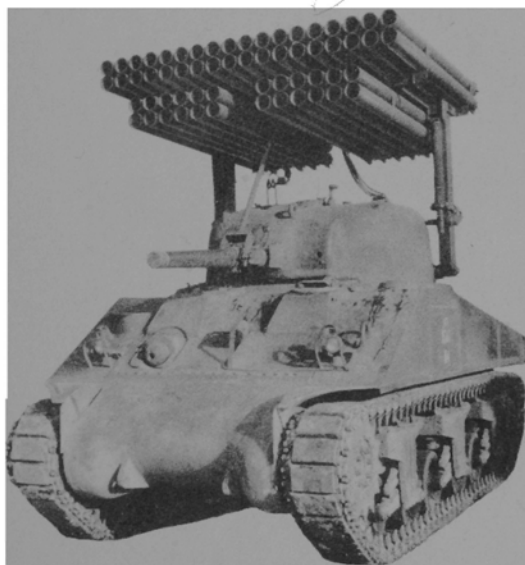
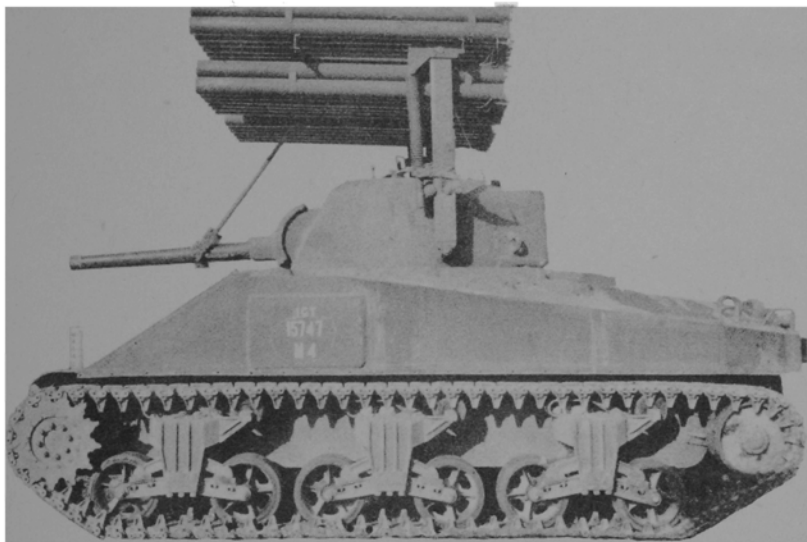

FIGURE 63. - T34 LAUNCHER ON MEDIUM TANK, M4-TYPE [REDACTED]

**NOTES**





CHAPTER 5 - 7.2" ROCKETS AND LAUNCHERS

SECTION I

ROCKET, H.E., 7.2", T14

94 ROCKET H.E., 7.2", T14

This rocket was designed to carry a powerful demolition charge. It is propelled by a fast-burning double base powder in extruded stick form.

The muzzle velocity is approximately 920 ft./sec., and the maximum range is approximately 6,000 yd. The Fuze, T1, and Fuze, Mk. 137 (Navy), are used with this rocket.

SECTION II

ROCKET, CHEMICAL, 7.2", T15

95 ROCKET, CHEMICAL, 7.2", T15

The T15 rocket is similar to the T14 rocket except for substitution of a chemical-loaded head in place of the

H.E. head used with the T14. The T15 weighs approximately 70 lb. The minimum range for this projectile is 500 yd. The T1 and Mk. 137 (Navy) fuzes are used.

SECTION III

ROCKET, H.E., AT, 7.2", T16

96 ROCKET, H.E., AT, 7.2", T17

This rocket is the same as the

T14 rocket except that it has a high-explosive antitank head.

SECTION IV

ROCKET, PRACTICE, 7.2", T17

97 ROCKET, PRACTICE, 7.2", T17

This is the T14 rocket with an

inert head substituted for the H.E. head on the T14.



# NOTES

## SECTION V

### ROCKET, CHEMICAL, 7.2", T21

#### 98 REASON FOR DEVELOPMENT

Military requirements exist for a method of projecting a large-capacity chemical shell from a light, mobile, and portable mount or gun. The T21 rocket, capable of carrying a heavy chemical charge, is the first of the 7.2" series of rockets to approach standardization. The T24 7.2" H.E. rocket has been virtually dropped from development; the modified Navy rocket, T37, is now serving as an interim type.

#### 99 GENERAL

a. Appearance.— See figure 64 and 65.

##### b. General data.—

Length, over-all (w/o fuze) ---- 45.4"  
Length, over-all (w/fuze) ----- 47.127"  
Length of head ----- 17-3/8"  
Length of motor, including  
tail vanes ----- 29.91"  
Diameter of motor ----- 3.25"  
Diameter of head ----- 7.2"  
Weight of head (w/charge) -- 29.46 lb.  
Chemical charge ----- 20.00 lb.  
Weight of motor  
(w/propellant) ----- 20.54 lb.  
Propellant (approx.) ----- 5.74 lb.  
Total weight of rocket ----- 50.00 lb.  
Fuze ----- Mk. 147  
Muzzle velocity ----- 600 ft./sec.  
Range (approx.) ----- 3,500 yd.

c. Use.— The T21 rocket carries a 20-lb. charge of FS smoke. It is used for laying down heavy smoke screens in tactical situations. Fired from a multiple launcher, the rockets will cover a large area as a result of normal dispersion.

d. Components.— The T21 chemical rocket consists of a chemical head, a motor, and a tail assembly. The Mk. 147 fuze is assembled with

the rocket. The head, motor, tail assembly, and fuze will be discussed in the following paragraphs.

#### 100 HEAD

The head consists of the container, adapter, burster tube, burster charge, chemical charge, shipping plug, and connector. These components are described in the following paragraphs.

a. Container.— The container is a bulb-shaped steel tube, open at both ends.

b. Adapter.— The adapter fits inside the flange on the forward end of the container and is brazed thereto. The wide, forward end of the adapter is internally threaded to seat the fuze.

c. Burster tube.— The burster tube is made of steel, fits inside the adapter, and extends downward into the container. The flange on the upper rim of the tube rests on the internal flange of the adapter. The tube and the adapter are held together by a press fit and sealed with white lead paste. The rear end of the tube is closed.

d. Burster charge.— The only information available concerning the burster charge is that it weighs 0.35 lb.

e. Chemical charge.— The chemical charge is 20 lb. of FS smoke.

f. Shipping plug.— The only information available concerning this component is that it is screwed into the adapter after the chemical charge is loaded into the container and is removed only to fit the fuze.

g. Connector.— The connector is a cylindrical steel plug which fits inside the rear end of the container and

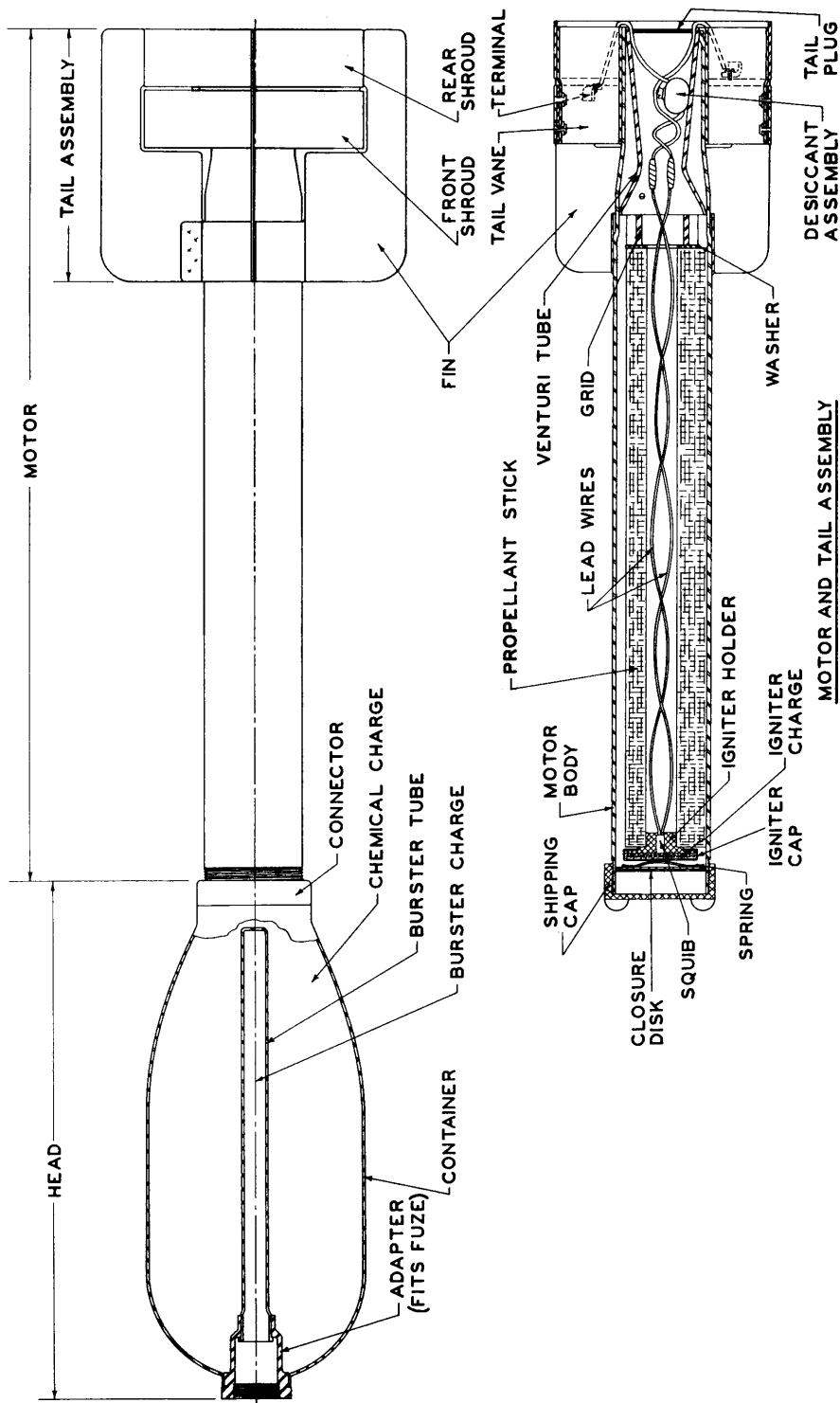

FIGURE 64. - ROCKET, CHEMICAL, 7.2", T21

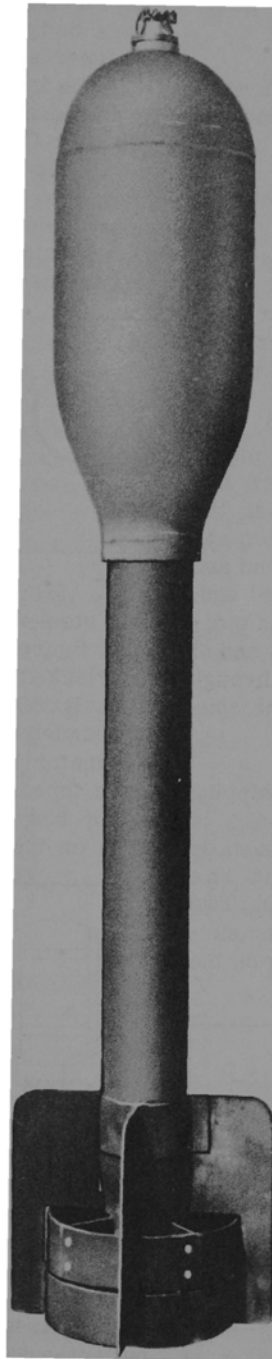

FIGURE 65. - ROCKET, CHEMICAL, 7.2", T21

## T21 ROCKET

is brazed thereto. The rear portion of the connector is threaded internally to seat the forward end of the motor body.

### 101 MOTOR

a. Appearance.— Figure 64 gives a cross section of the motor and its components.

b. Components.— The motor consists of a motor body, shipping cap, venturi tube, grid, and the propellant assembly. In the following subparagraphs the first four of these components will be described. The propellant assembly will be discussed in a separate paragraph.

(1) Motor body.— The motor body is a steel tube .11" thick and 28.935" long. It is tapered near the rear end. This taper commences approximately 7" from the rear end and ceases approximately 4" from that end. The rear portion of the body has a diameter of 2.755". The forward end of the tube is externally threaded through 1" of its length and fits inside the connector of the head.

(2) Shipping cap.— The shipping cap, made of drab-colored plastic, is shaped as shown in figure 66. The walls are internally threaded to fit the threaded end of the motor body. Two winglike projections on the upper surface of the cap assist in screwing on the cap.

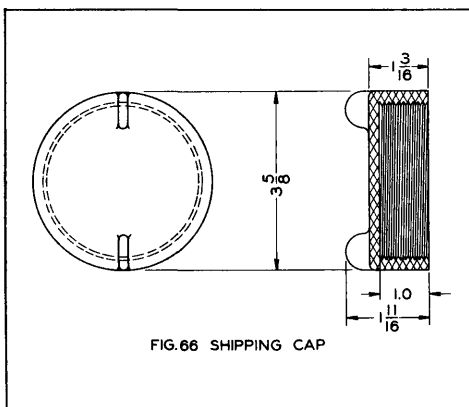

(3) Venturi tube.— The venturi tube is shown in figure 67. It is slipped down through the large, open end of the motor body, and the end B is welded to the inner edge of the motor-body rim. The tube is steel and has the shape and dimensions illustrated in figure 67. The hole C is .125" in diameter and allows gas to escape into the space between tube and motor body. Gas in this cavity tends to equalize the pressure on both sides of the venturi tube and prevent its distortion.

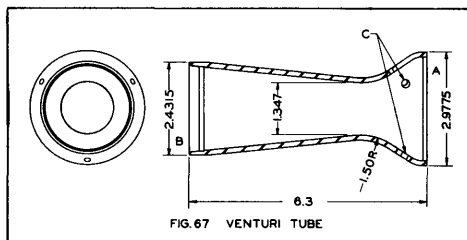

(4) Grid.— The grid consists of four steel pieces, each notched as shown in A, figure 68. These four pieces are interlocked to form the assembly shown in B, figure 68. Each end of each piece is rounded to fit the internal surface of the motor body. The grid is dropped down through the large opening in the motor body and comes to rest cross-wise on the upper rim of the venturi.

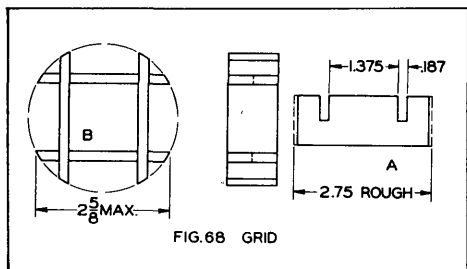

### 102 PROPELLANT ASSEMBLY

This assembly is a part of the motor assembly, but for sake of simplicity of presentation it is described in this separate paragraph. The propellant assembly consists of the propellant-powder assembly, closure disk, spring, igniter assembly, desiccant assembly, and tail plug. These compo-

nents are described in subparagraphs a through f below; in subparagraph g, the assembly and functioning of the propellant are discussed.

a. Propellant-powder assembly.

This assembly consists of four sticks of propellant powder and four propellant-powder washers. Each of the four washers is cemented to one end of the four sticks. The propellant is ignited at its forward end rather than at its rear end as was the case in the previously discussed rockets.

(1) Propellant powder.— A stick of propellant powder is 20.5" long and has a 1" axial hole. The view in figure 69 shows the three longitudinal ridges on the surface of the stick. There are eight sets of three holes each in each stick. Figure 69 shows the relative position of one set of holes. These holes make the propellant stick burn more evenly.

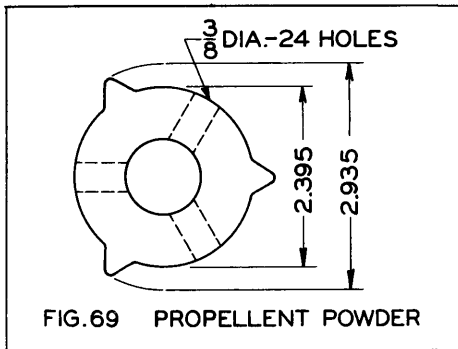
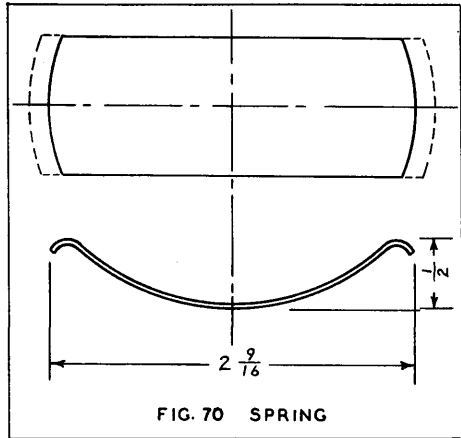

**FIG. 69 PROPELLANT POWDER**

(2) Propellant-powder washer. The washer is made of celluloid 1/8" thick. The external diameter is 2-15/32", and the internal diameter is 1-3/64".

b. Closure disk.— The closure disk is of black, hard fiber 3.03" in diameter and 1/8" thick.

c. Spring.— The spring is made of annealed steel and has the shape and dimensions shown in figure 70. The spring is welded to the face of the igniter cap (see fig. 64).

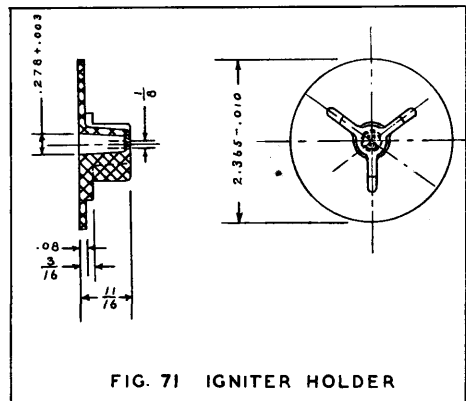

**FIG. 70 SPRING**

d. Igniter assembly.— The igniter assembly consists of an igniter cap, igniter holder, electric squib, and igniter charge. These igniter components will be described in the following subparagraphs.

(1) Igniter cap.— The igniter cap is 2.375" in diameter and 3/8" deep. It is made of steel .0179" thick.

(2) Igniter holder.— The igniter holder is made of clear plastic and has the shape and dimensions illustrated in figure 71. The electric squib is slipped into the axial hole of the igniter holder. After the igniter charge is poured into the igniter cap, the holder is cemented to the cap (see fig. 64.)



**FIG. 71 IGNITER HOLDER**

(3) Electric squib.— The squib is a commercial electric igniter with



two plastic-coated lead wires, each 24" long. The free ends of the lead wires are stripped for a distance of 1". To each stripped end, 12" of insulated lead wire is bound with friction tape. The free ends and the taped ends of each of these second lengths of wire are stripped for 3/4". One wire is attached to the terminal on the front shroud of the tail assembly, and the other is attached to the rear-shroud terminal.

(4) Igniter charge.— The igniter charge is black powder.

e. Desiccant assembly.— The desiccant assembly consists of three 5" squares of cheesecloth bound into a bag. The bag contains 30 to 35 grains of silica gel. This assembly absorbs moisture and prevents the moisture content of the propellant from becoming too high.

f. Tail plug.— The tail plug is black, hard fiber, 1/8" thick and 2.25" in diameter. Opposite each other on the rim of the plug are two small notches.

g. Assembly and functioning.

(1) Assembly.— The four propellant sticks with washers attached are inserted in the threaded end of the motor body, washer ends first, and rest on the grid. The igniter assembly is then inserted in the same end; the wires are drawn through the venturi tube. The projection on the igniter holder spaces the propellant sticks. The closure disk is fitted into the motor body, pressed down upon the spring, and cemented in place. The tension of the spring holds the igniter firmly against the propellant sticks, holding the latter in place. The desiccant assembly is placed in the venturi tube. The tail plug is inserted in the rear of the venturi tube with one igniter lead wire in each notch. The tail plug is cemented in place.

(2) Functioning.— When electric current is turned on, the squib explodes

and sets off the igniter charge. The flame of the igniter charge starts the inside and outside of the upper half of each propellant stick burning. The rapid burning of the sticks results in a high gas pressure that provides the motive power for the rocket.

103 TAIL ASSEMBLY

The tail assembly serves to stabilize the rocket in flight and as a contact point for the electric current that explodes the igniter. The tail assembly consists of two tail vanes, a front and rear shroud, and four fins. The components are described as follows:

a. Tail vanes.— Each vane is made of steel and is shaped roughly like a W. The curved middle portion A (see fig. 72) is welded to the rear outer surface of the motor body. The feet of the vanes, labeled B, support the front and rear shrouds. The rear shroud is welded to end B", and the front shroud is riveted to end B' through the holes C.

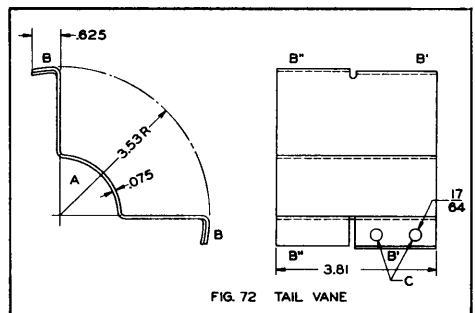

FIG. 72 TAIL VANE

b. Front shroud.— The front shroud is a steel ring 7.20" in diameter and 1.94" high. Equally spaced about the ring are four pairs of holes. The front shroud is slipped over the feet of the vanes, and the holes in the shroud and in the feet are aligned. Shroud and vanes are fastened by means of insulated rivets. A terminal for one of the igniter lead wires is attached to the inner surface of the shroud.

c. Rear shroud.— The rear shroud is identical to the front shroud

except that it has no holes and is welded at three points to each vane foot. The rear shroud is assembled with a .12" gap between it and the front shroud. A terminal for the other igniter lead wire is attached to the inner surface of the shroud.

**d. Fin.**— The steel fins are welded to the outside of the motor body just forward of the taper. Area A is welded to the motor body, and end B is welded to blade C of an adjacent fin (see fig. 73). End D extends rearward along the motor body, and the edge E is welded to the outer surface of the rear shroud

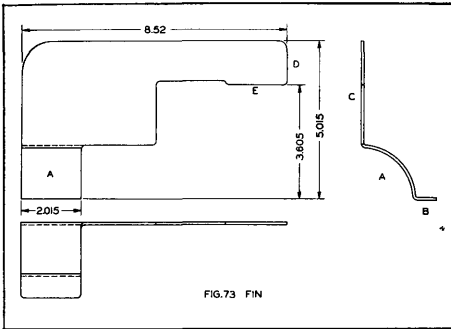

**104 FUZE, MK. 147 (NAVY)**

**a. General.**— The Army procures this fuze from the Navy. It is 2.414" long and 1.750" in greatest diameter (see fig. 74). The threads just below the shoulder engage those in the adapter of the T21 rocket. Into the bottom of the fuze is screwed an adapter that seats the burster. This burster ruptures the case and scatters the chemical contents of the rocket. The fuze is made of cadmium-plated steel and weighs approximately 1/2 lb. without the burster.

**b. Action.**— (1) The fuze is shipped with the components in the position shown in figure 74. After the fuze is screwed into the rocket, the following steps are taken prior to firing:

(a) The shipping-guard tape is removed. This tape is wrapped in a clockwise direction over the shipping

guard and body in such a manner as to extend over and completely cover the body shoulder.

(b) The shipping guard is removed. This is a brass cup with a rounded bottom that fits over the propeller assembly and is held in place on the body shoulder by the shipping-guard tape. The removal of the shipping guard exposes the propeller assembly and the upper half of the body.

(c) The safety wire is removed. On the safety wire is a white tag, 3" x 1". In black letters appears the following information:

REMOVE SAFETY WIRE  
over

(obverse)

REPLACE SAFETY WIRE  
IF ROUND IS UNFIRED  
over

(reverse)

The underlined words are in red. The removal of the safety wire permits movement of the set-back pellet when sufficient acceleration is gained.

(2) When the rocket is fired the set-back pellet moves to the rear against the tension of the set-back-pellet spring. The propeller locking pin, which is staked to the pellet and extends through a hole in the body, moves to the rear with the pellet. This rearward movement of pellet and pin frees the propeller assembly and permits it to rotate.

(3) The propeller assembly begins to spin. After 2.1 turns it has moved outward far enough so that the propeller lock pin on returning to its

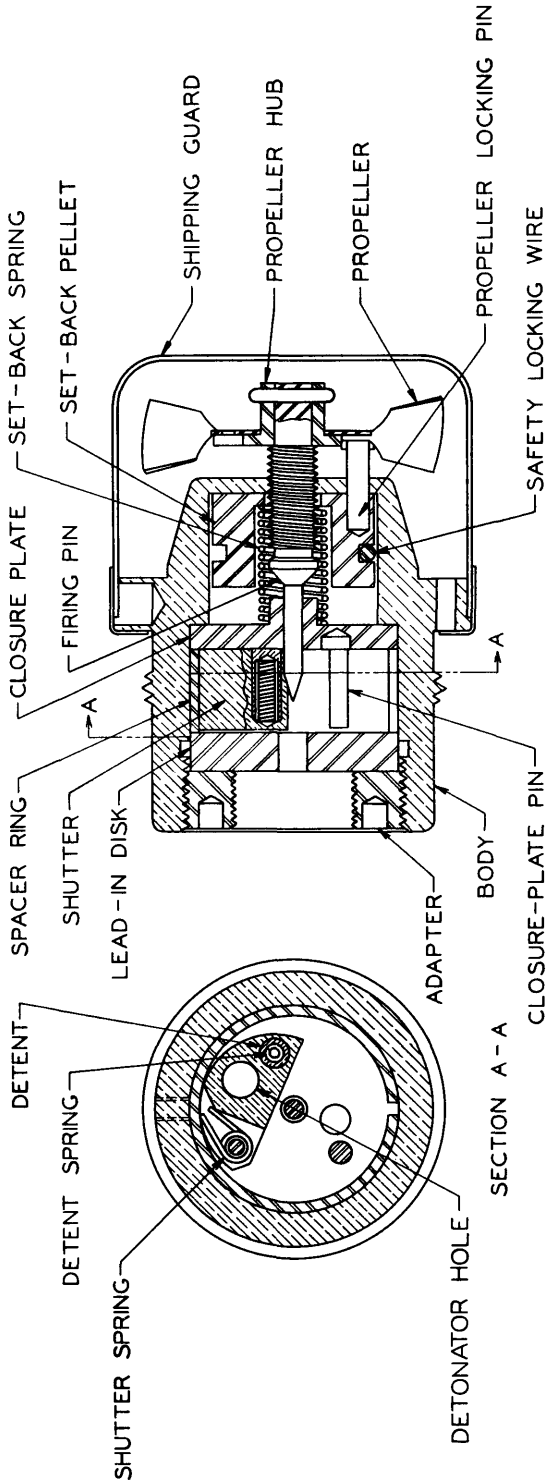

FIGURE 74. - FUZE, MK. 147 (NAVY) FOR T21 CHEMICAL ROCKET

forward position, cannot act as a positive lock. The fuze is not yet armed. The propeller assembly continues to rotate, and is unscrewed from the body. The assembly then rotates freely, for it is free of the body threads, which are riding in the groove next to the shoulder of the pin. The point of the firing pin has withdrawn into the central hole of the closure plate, freeing the shutter. The shutter can now move.

(4) The shutter, cocked by the "mouse-trap" shutter spring, rotates clockwise until it is stopped by the closure-plate pin. In this position, the detonator assembly, housed in the central shutter hole, is in line with the firing pin and the lead-cup charge. The shutter is locked in this position by a spring-actuated detent that moves into a recess in the closure plate. The fuze is now armed.

(5) On impact, the propeller assembly is driven rearward and the firing-pin threads shear the body threads. The firing pin drives into the detonator assembly, causing it to explode. This explosion is carried through the tetryl lead and the tetryl burster charge. The action of the fuze is complete.

c. Explosive components.

(1) Detonator assembly.— The components of the detonator are an upper charge of .052 gm. of lead-azide priming mixture, an intermediate charge of .110 gm. of lead azide, and a lower charge of .070 gm. of tetryl. The upper end of the detonator is identified by a green disk; the lower end by a red disk.

(2) Lead-cup charge.— The lead cup is cemented into place in the central

hole of the lead-in disk and contains .075 gm. of tetryl. The lead cup is made of aluminum and is .182" in diameter at the rim and .190" deep.

d. Packing.— No information is available at present.

e. Marking.— No information is available at present.

f. Safety features.— (1) The safety locking wire prevents movement of the set-back pellet until the wire is removed.

(2) The set-back-pellet spring will compress completely only under a pellet pressure caused by an acceleration of 40 gravities.

(3) The propeller must rotate 2.1 turns before arming can commence.

(4) The firing pin must withdraw completely before the shutter can snap over.

## 105 PAINTING AND MARKING

a. Head.— The head is painted gray. About the nose of the head is painted a narrow yellow band, and stenciled on the head in yellow is the nomenclature of the rocket.

b. Motor and tail assembly. All external surfaces of motor and tail assembly (except contact points in the latter) are painted olive drab with nomenclature stenciled in yellow.

c. Note.— Detailed information on a and b above is not available.

## 106 PACKING

No information is available.

SECTION VI

ROCKET, H.E., 7.2", T24

107 REASON FOR DEVELOPMENT

See paragraph 98 of the preceding section.

108 GENERAL

The T24 rocket is identical to the T21 chemical rocket with the following exceptions:

a. The head has been slightly

redesigned, since the T24 carries a 21.60 lb. charge of high explosive.

b. The fins in the tail assembly of the T21 rocket are not assembled with the T24 rocket.

c. The head of the T24 rocket is painted olive drab with yellow lettering.

SECTION VII

ROCKET, H.E., 7.2", T37

109 REASON FOR DEVELOPMENT

Military requirements indicated a need for a rocket capable of carrying a heavy charge of high explosive. This heavy charge was to be used for breaching concrete emplacements, and the effect was to be achieved by blast.

110 GENERAL

a. Appearance. - See figure 75. The T37 is of modified Navy design serving as an interim type.

b. Data. -

Length (approx.) -----	36"
Length of container -----	20"
Length of motor -----	16"
Diameter of fin and container --	7.2"
Diameter of motor -----	3.25"
Weight (approx.) -----	60 lb.
Weight of charge -----	
Weight of propellant -----	
Velocity (approx.) -----	170 ft./sec.
Range -----	

c. Components. - Nearly all the components of this rocket are obtained from the Navy. The T37 is patterned after a point-detonating Navy rocket of simple design. The T37 rocket has been redesigned to provide for a base-detonating fuze. The head is made of thin steel to give the maximum blast effect from the charge.

d. Propellant. - The propellant is a Navy double-base solventless powder. It is a single unperforated, cruciform stick. The outer edges of the stick are inhibited in manufacturing, and only the inner edges are permitted to burn.

111 FUZE, B.D., MK. 146

This fuze is obtained from the Navy and is illustrated in cross section in figure 76. It is pressure operated and is located in the rear surface of the head. The rear surface of the fuze extends into the motor and is sub-

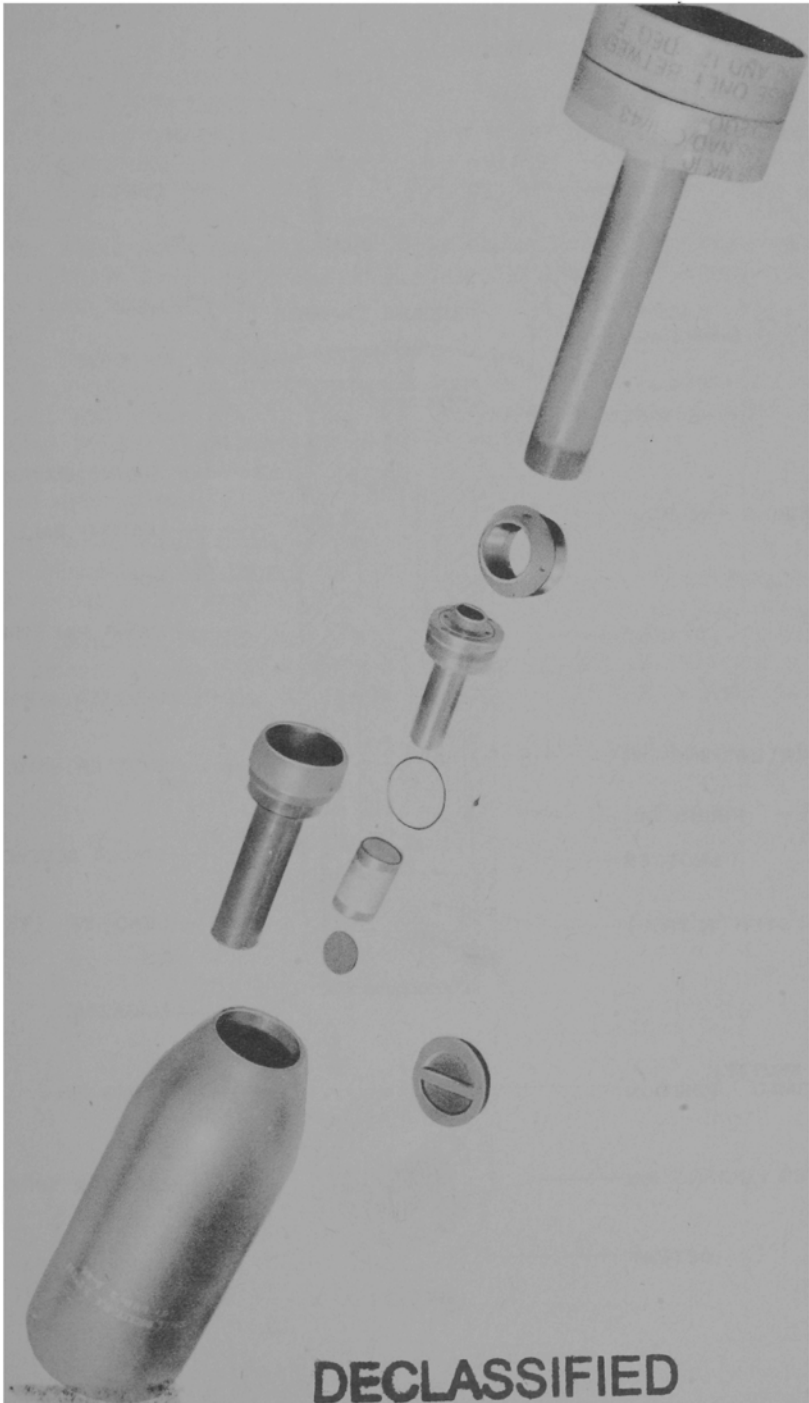

FIGURE 75. - ROCKET, H.E., 7.2" DISASSEMBLED

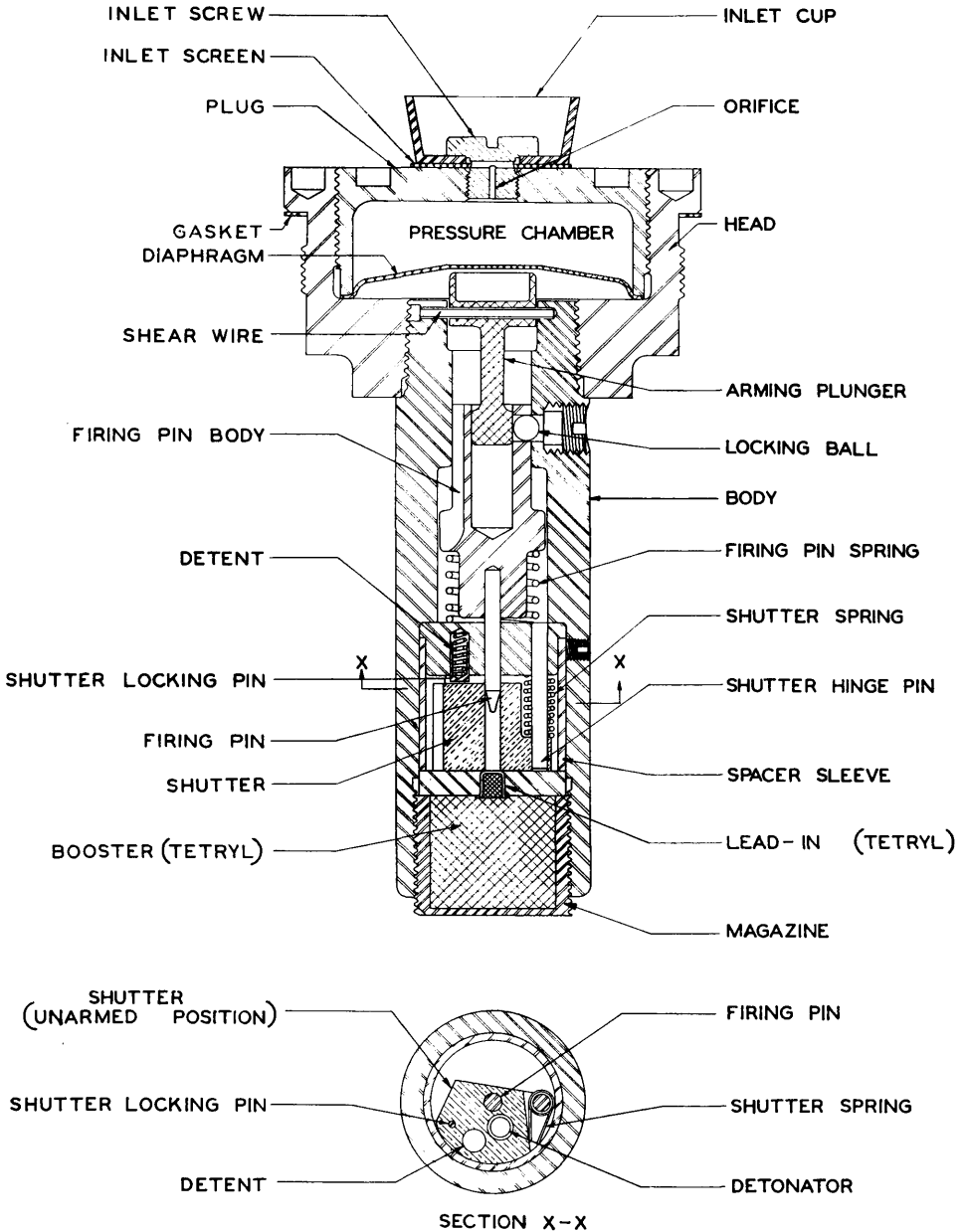

FIGURE 76. - FUZE, B.D., MK. 146

jected to the pressure of the propellant gas. The action of the fuze is described as follows:

a. Gas from the burning propellant seeps through the inlet screen, through the transverse hole in the inlet screw, and through the inlet-screw orifice.

b. When sufficient gas pressure is built up in the pressure chamber, the diaphragm is depressed.

c. Under the pressure of the diaphragm, the arming plunger is driven downward. Sufficient pressure must be exerted by the diaphragm on the arming plunger to cause the latter to shear the shear wire.

d. When the arming plunger moves downward, the locking ball moves into the recess in the arming plunger.

e. With the locking ball in the arming-plunger recess, the firing-pin body, under tension of the firing-pin

spring, is forced upward, withdrawing the firing pin from its position in the shutter. When in the shutter, the firing pin prevents rotation of the shutter.

f. The shutter, no longer restrained by the firing pin, is forced in a clockwise direction by the shutter spring, rotating on the shutter hinge pin. The shutter rotates until halted by the shutter locking pin and is locked in this position by the spring-actuated detent.

g. In this position of the shutter, the shutter detonator is in line with the firing pin above and the lead-in below.

h. On impact of the rocket, the firing pin continues forward by inertia, and drives into the detonator. The detonator is exploded, and this explosion travels through the lead-in, into the booster. The booster explodes, setting off the rocket charge. The function of the fuze is completed.



# NOTES







**NOTES**

# DECLASSIFIED

8"  
ROCKETS

## CHAPTER 6—8" ROCKETS



### 113 GENERAL

The 8" rocket consists of a 100-lb. bomb assembled by means of an adapter to an M8, 4.5" motor. The fin assembly of the bomb replaces the M8 tail assembly. A standard bomb fuze, slightly modified so that it will arm at the slow rocket velocity, will be used.

NOTES

DECLASSIFIED

CHAPTER 7—10" ROCKETS

SECTION I

ROCKET, H.E., 10", T10

114 GENERAL

The rocket, H.E., 10", T10, is a ground-to-ground projectile which can be used for demolition. When used for demolition purposes, the head is filled with TNT. Chemical may be substituted when it is desired to lay down gas. The rocket has fixed fins and is fired electrically.

Range (45° elevation) -----	2,200 yd.
Weight of head (w/filler) ----	117 lb.
Filler (TNT) -----	77 lb.
Head -----	40 lb.
Fuze (bomb, nose) -----	M110
Motor:	
Length -----	23-1/2"
Diameter -----	10"
Propellant (double-base powder) -----	108 sticks
Length, each stick -----	5"
Outside diameter -----	7/8"
Inside diameter -----	1/4"
Burning time -----	.2 sec.
Internal pressure --	2,800 lb./sq. in.

115 PRINCIPAL CHARACTERISTICS

Weight, total -----	210 lb.
Length, over-all -----	53"
Muzzle velocity -----	440 ft./sec.

SECTION II

ROCKET, H.E., 10", T10E1 (HIGH VELOCITY)

116 GENERAL

This rocket differs from the T10 in the following specifications.

Total weight -----	190 lb.
Muzzle velocity -----	1,050 ft./sec.
Maximum range -----	5,000 yd.

Weight of head (w/filler) -----	68 lb.
Filler (TNT) -----	40 lb.
Head -----	28 lb.
Fuze -----	M4
Propellant (double-base powder) -----	162 sticks

SECTION III

ROCKET, H.E., AT, 10", T10E2

117 GENERAL

Rocket T10E2, differs from the T10 only in its weight (180 lb.) and the use of an H.E. AT head employing the

hollow-charge principle. The head, without filler, weighs 40 lb. The weight of the TNT filler is 35 lb.





# NOTES



**DECLASSIFIED**

**ROCKETS AND LAUNCHERS, ALL TYPES • OS 9-69**

**DECLASSIFIED**