

ENGINEERING PROBLEMS
ILLUSTRATING MATHEMATICS

*The quality of the materials used in the manufacture
of this book is governed by continued postwar shortages.*

Engineering Problems Illustrating Mathematics

*A Project of the Mathematics Division of the Society
for the Promotion of Engineering Education*

JOHN W. CELL

Chairman of Committee

*Associate Professor of Mathematics in the College
of Engineering, North Carolina State College*

FIRST EDITION
FIFTH IMPRESSION

McGRAW-HILL BOOK COMPANY, INC.

NEW YORK AND LONDON

1943

ENGINEERING PROBLEMS ILLUSTRATING MATHEMATICS

COPYRIGHT, 1943, BY THE

EDITORIAL COMMITTEE

J. W. CELL, W. C. BRENKE,
G. E. MOORE, C. C. TORRANCE

PRINTED IN THE UNITED STATES OF AMERICA

*All rights reserved. This book, or
parts thereof, may not be reproduced
in any form without permission of
the Editorial Committee.*

CONTENTS

	PAGE
FOREWORD: A PROJECT OF THE MATHEMATICS DIVISION OF THE SOCIETY FOR THE PROMOTION OF ENGINEERING EDUCATION.	v
PREFACE.	ix
INTRODUCTION BY ROBERT E. DOHERTY.	xi

PART I

COLLEGE ALGEBRA

RADICALS AND EXPONENTS.	1
QUADRATIC EQUATIONS	2
COMPLEX NUMBERS.	5
LOGARITHMS	5
SIMULTANEOUS EQUATIONS.	7
VARIATION.	8
BINOMIAL THEOREM.	9
PROGRESSIONS	10
THEORY OF EQUATIONS	12
DETERMINANTS AND SIMULTANEOUS LINEAR EQUATIONS	15

PART II

TRIGONOMETRY

FUNDAMENTAL IDENTITIES.	22
RIGHT TRIANGLES	23
OBLIQUE TRIANGLES.	25
MULTIPLE ANGLE IDENTITIES	27
GRAPHS OF THE TRIGONOMETRIC FUNCTIONS. LINE VALUES.	28
TRIGONOMETRIC EQUATIONS	31
COMPLEX NUMBERS. DE MOIVRE'S THEOREM	33

PART III

ANALYTIC GEOMETRY

ELEMENTARY FORMULAS.	37
STRAIGHT LINES	38
CURVE SKETCHING	43
GRAPHS OF THE CURVES: $y = ax^n$	46
CIRCLES.	49
PARABOLAS.	51
ELLIPSES	54

	PAGE
HYPERBOLAS.	55
ROTATION OF AXES	57
GRAPHS OF SINE WAVES.	58
EXPONENTIAL AND LOGARITHMIC GRAPHS	61
HYPERBOLIC FUNCTIONS.	63
POLAR COORDINATES	64
PARAMETRIC EQUATIONS.	66
EMPIRICAL CURVES	71
ELEMENTARY FORMULAS IN SOLID ANALYTIC GEOMETRY.	75
SURFACES IN SOLID ANALYTIC GEOMETRY	79

PART IV

DIFFERENTIAL CALCULUS

USES AND INTERPRETATIONS OF DERIVATIVES.	83
TANGENT AND NORMAL	86
CURVE SKETCHING. MAXIMUM, MINIMUM, AND FLEX POINTS	90
MAXIMUM AND MINIMUM PROBLEMS.	93
VELOCITY AND ACCELERATION. RECTILINEAR MOTION	100
VELOCITY AND ACCELERATION. CURVILINEAR MOTION	102
DIFFERENTIALS.	105
CURVATURE	106
INDETERMINATE FORMS	107
RELATED RATES	110
PARTIAL DIFFERENTIATION.	110

PART V

INTEGRAL CALCULUS

CONSTANT OF INTEGRATION	114
EVALUATION OF DEFINITE INTEGRALS.	122
DEFINITE INTEGRALS. SIMPSON'S RULE AND TRAPEZOIDAL RULE.	125
AREAS. AVERAGE ORDINATE.	127
LENGTH OF ARC. AREAS OF SURFACES OF REVOLUTION	131
VOLUMES	133
FIRST AND SECOND MOMENTS.	135
TOTAL FORCE	140
WORK.	141
OTHER APPLICATIONS OF INTEGRAL CALCULUS	143
INFINITE SERIES	149
HYPERBOLIC FUNCTIONS.	153
INDEX.	157
ANSWERS	161

PREFACE

The problems in this collection are designed to give to the freshman and sophomore engineering student some understanding of the uses of mathematics in junior and senior engineering courses, and hence of the necessity of a thorough foundation in mathematics. These problems should help to answer the eternal question, "Why study this topic?"

The early training of an engineering student should contain an appreciation of how engineering problems are translated into mathematics problems. The Report on the Aims and Scope of Engineering Curricula (in *The Journal of Engineering Education*, vol. 30, March, 1940, pp. 563-564) states that

"The scientific-technological studies should be directed toward:

"1. Mastery of the fundamental scientific principles and a command of basic knowledge underlying the branch of engineering which the student is pursuing. This implies:

"*a.* grasp of the meaning of physical and mathematical laws, and knowledge of how they are evolved and of the limitations in their use;

"*b.* knowledge of materials, machines, and structures.

"2. Thorough understanding of the engineering method and elementary competence in its application. This requires:

"*a.* comprehension of the interacting elements in situations which are to be analyzed;

"*b.* ability to think straight in the application of fundamental principles to new problems; . . ."

Another quotation from an address by Dr. Marston Morse (President of the American Mathematical Society and Chairman of the War Preparedness Committee), which he delivered to the National Council of Teachers of Mathematics (December, 1940), will further emphasize the purposes of this collection:

"Teachers of mathematics should present to their pupils technological and industrial applications whenever possible. This can and should be done without abandoning the concept of mathematics as a general tool."

Most of these problems are suited to direct assignment to the superior student, and many of them can be assigned even to an average student.

Some problems, marked with asterisks, would more properly be used in outline form in the classroom or for bulletin board display.

Some engineering terminology is necessary in stating engineering problems. The Committee has tried to keep the use of unfamiliar terms to a minimum and has resorted at times to somewhat crude translations into nontechnical language. However, many engineering freshmen have some technical vocabulary derived from a high-school physics course or from some hobby.

Two groups of important topics in mathematics receive little or no attention in these problems. One group consists of those topics, such as variation in college algebra and mensuration in trigonometry, for which most mathematics texts contain sufficient application problems. The other group consists of essentially mathematical concepts that form the groundwork for subsequent material of application.

These remarks by no means imply that mathematics courses should be solely utilitarian. It is important, furthermore, that these problems be used as supplementary material and for their avowed purposes. The necessary drill problems should continue to be of the traditional variety. This collection will be *misused* if there is any attempt to teach junior or senior engineering concepts in the freshman or sophomore mathematics classroom.

JOHN W. CELL.

NORTH CAROLINA STATE COLLEGE,
May, 1943.

ENGINEERING PROBLEMS ILLUSTRATING MATHEMATICS

PART I

COLLEGE ALGEBRA

RADICALS AND EXPONENTS

1. If $\frac{p_2}{p_1} = \left(\frac{2}{k+1}\right)^{k/(k-1)}$, show that $\left[\left(\frac{p_2}{p_1}\right)^{2/k} - \left(\frac{p_2}{p_1}\right)^{(k+1)/k}\right]^{1/2}$ reduces to $\left(\frac{2}{k+1}\right)^{1/(k-1)} \sqrt{\frac{k-1}{k+1}}$. This simplification arises in a derivation for the theory of flow in a nozzle in thermodynamics.

2. The gas in an engine expands from a pressure p_1 and volume v_1 to a pressure p_2 and volume v_2 according to the equation $\frac{p_2}{p_1} = \left(\frac{v_1}{v_2}\right)^n$. (Boyle's law is the special case of this equation when $n = 1$.) Solve for v_1 in terms of v_2 , p_1 , p_2 , and n .

3. The study of a vacuum tube involves the following equations: $I = kE^{3/2}$, $P = EI$, $G = I/E$, and $R = E/I$, where I is current in amperes, E is voltage in volts, R is resistance in ohms, P is power in watts, and G is the conductance; k is a constant. Determine formulas for each of the quantities E , I , P , G , and R , respectively, in terms of each of the other quantities. (There will be 20 such equations in all.)

4. Simplify the following expressions:

$$(a) \quad \frac{2}{3a^2} \left[a(ax+b)^{1/2} + (ax-2b) \left(\frac{1}{2}\right) (ax+b)^{-1/2}(a) \right].$$

$$(b) \quad \frac{2}{\sqrt{b}} \frac{1}{1 + \frac{ax-b}{b}} \left(\frac{1}{2}\right) \left(\frac{ax-b}{b}\right)^{-1/2} \left(\frac{a}{b}\right).$$

Note to Teachers: Additional problems of this character may be obtained by differentiating the answers in any standard table of integrals. Similar problems may be obtained for use in trigonometric simplification.

QUADRATIC EQUATIONS

5. The design of a square timber column of yellow pine, of length 20 ft., to support a load of 30,000 lb., is accomplished by the use of an "approximate straight-line column formula":

$$\frac{P}{a} = 1,000 - 6 \left(\frac{L}{r} \right).$$

In this problem $P = 30,000$ lb., $a = w^2$ (where w is the width of the

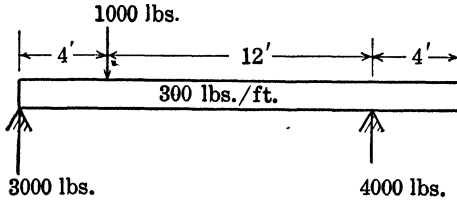

FIG. 1.

square column in inches), $L =$ length of column $= (20)(12)$ in., and $r = w/\sqrt{12}$ (a property of the shape of the cross section). Substitute these quantities in the given equation and solve for w correct to the nearest second decimal.

6. Figure 1 shows a beam that supports its own weight of 300 lb. per ft. and a concentrated load of 1,000 lb. at a point x ft. from the left end where there is no compression or tension (push or pull) in the beam. x must be larger than 4 and less than 16 and is a root of the equation

$$3,000x - 1,000(x - 4) - 150x^2 = 0.$$

Find x .

7. Figure 2 shows a right circular cylinder of height H and radius r , mounted on a smooth hemisphere of radius r . The combined body will not tip if the height H is less than the positive value of H which satisfies the following equation:

$$(r) \left(\frac{2\pi r^3}{3} + \pi r^2 H \right) = \left(\frac{2\pi r^3}{3} \right) \left(\frac{5r}{8} \right) + (\pi r^2 H) \left(r + \frac{H}{2} \right).$$

Determine this critical value for H .

8. A study of the flow of a gas through a nozzle requires the solution of the equation

$$\frac{2}{k} [r^{(2/k)-1}] - \left(\frac{k+1}{k} \right) (r^{1/k}) = 0$$

COMPLEX NUMBERS

17. In electrical engineering it is customary to use the complex numbers E , I , and Z to designate, respectively, the voltage, current, and impedance. If $E = IZ$, find the third quantity (in simplified form) when given,

- (a) $E = 100 + j40$ volts, $I = 4 + j3$ amp.; ($j = \sqrt{-1}$).
 (b) $I = 2 + j3$ amp., $Z = 30 - j12$ ohms.
 (c) $E = 120$ volts, $Z = 20 - j20$ ohms.

18. Two loads $Z_1 = 3 + j4$ ohms and $Z_2 = 8 - j6$ ohms are connected in parallel. Determine an equivalent single load Z from the relation $1/Z = 1/Z_1 + 1/Z_2$.

19. If $Y = 1/Z = G - jB$ and if $Z = R + jX$, determine relations for the real quantities G and B in terms of the real quantities R and X . G and B are called, respectively, the conductance and the susceptance in the electric circuit.

20. A study of damped forced vibrations requires the solution for x of the equation

$$-mw^2x + jwcx + kx = P.$$

m , w , c , k , and P are real constants and $j = \sqrt{-1}$. Show that

$$x = \frac{P(-mw^2 + k - jwc)}{(-mw^2 + k)^2 + w^2c^2}.$$

Also show that the numerical value of this complex number solution is given by

$$|x| = \frac{P}{[(-mw^2 + k)^2 + w^2c^2]^{1/2}}.$$

LOGARITHMS

21. A gas expands from a temperature $T_1 = 60^\circ + 460^\circ = 520^\circ$ (T_1 is in degrees absolute on the Fahrenheit scale) and pressure $p_1 = 89.7$ lb. per sq. in. until the pressure is $p_2 = 39.7$ lb. per sq. in. If the relation between temperature and pressure is

$$\frac{T_2}{T_1} = \left(\frac{p_2}{p_1}\right)^{(n-1)/n},$$

where $n = 1.40$, determine T_2 by aid of a four-place logarithm table.

22. Given that $\Delta s = wc_v \log_e (T_2/T_1)$ (an equation that you will study in thermodynamics), compute Δs if $w = 4$, $c_v = 0.1373$, $T_2 = 940$, and $T_1 = 500$.

23. The work done in compressing a gas at constant temperature from a pressure p_0 lb. per sq. ft. and volume v_0 cu. ft. to a pressure

p_1 lb. per sq. ft. and volume v_1 cu. ft. is given by

$$W = p_0 v_0 \log_e \left(\frac{v_1}{v_0} \right) \text{ ft.-lb.}$$

Determine W if $p_0 = 20$ lb. per sq. in., $p_1 = 35$ lb. per sq. in., and $v_0 = 3$ cu. ft. v_1 can be determined from the relation $p_1 v_1 = p_0 v_0$.

24. The average molecular weight M of a petroleum fraction may be approximately determined from its atmospheric boiling point, $t^\circ\text{C}$., from the equation

$$\log_{10} M = 2.51 \log_{10} (t + 393) - 4.7523.$$

a. Restate this equation in exponential form; *i.e.*, solve for t in terms of M .

b. Compute M , correct to the nearest integer, for $t = 160^\circ\text{C}$.

25. It has long been customary to state the brightness of stars in *magnitudes*, where $M = -2.5 \log_{10} (I/I_1)$ is the magnitude of a star whose light intensity is I , where I_1 is the light intensity of a star of the first magnitude. Note that the less brilliant the star the higher is its magnitude.

Determine the ratio of the light intensities I/I_1 for a star of the fourth magnitude ($M = 4$).

26. Show that the equation $\ln i = -\frac{t}{RC} + \ln \frac{E}{R}$, where $\ln x = \log_e x$, can be written in the exponential form $i = \frac{E}{R} e^{-t/RC}$. This problem is typical of many derivations in electrical engineering. In the resulting equation i is the current in amperes in a series circuit t sec. after the switch is closed, E is the voltage of the battery in the circuit, R is the resistance in ohms, and C is the capacitance of the condenser in farads.

27. A boat is brought to rest by means of a rope, which is wound three times around a capstan. The boat exerts a pull on the rope of 2,000 lb. Determine the pull on the other end of the rope (F measured in pounds) if

$$2,000 = Fe^{(3)(2\pi)(0.25)}$$

The equation used in this problem is $T = Fe^{\mu\alpha}$ where α is the angle in radians subtended by the contact between the rope and post and μ is the coefficient of friction between the rope and the post.

28. The pressure P in pounds per square inch required to force water through a pipe L ft. long and d in. in diameter at a speed of v ft. per sec. is given by

$$P = 0.00161 \frac{v^2 L}{d}.$$

a. Solve for v in terms of P , L , and d .

b. Determine P correct to the nearest three significant figures if $v = 8$ ft. per sec., $L = 2$ miles, and $d = 6$ in.

SIMULTANEOUS EQUATIONS

29. The study of the expansion of a gas in an engine utilizes the equations $p_1V_1^n = p_2V_2^n$, $p_1V_1/T_1 = p_2V_2/T_2$, where n is a positive constant, p is pressure, V is volume, and T is absolute temperature. Use these two given equations to obtain the following equations:

$$(a) \quad \frac{T_1}{T_2} = \left(\frac{V_2}{V_1}\right)^{n-1} = \left(\frac{V_1}{V_2}\right)^{1-n}.$$

$$(b) \quad \frac{T_1}{T_2} = \left(\frac{p_1}{p_2}\right)^{(n-1)/n}.$$

30. In electrical engineering occur the two simultaneous equations

$$\frac{SK}{K^2 - 1} = R, \quad S\left(\frac{K^2 + 1}{K^2 - 1}\right) = D. \quad (K \text{ cannot be } \pm 1)$$

Eliminate S and solve for K in terms of D and R . Also show that the two answers for K are reciprocals.

31. Euler's column formula (from strength of materials) is $\frac{P}{a} = \frac{\pi^2 E}{(l/r)^2}$.

The Gordon-Rankine formula is $\frac{P}{a} = \frac{s}{1 + \varphi(l/r)^2}$. Determine an expression for φ in terms of l/r so that the value of P/a will be the same from the two equations.

32. A beam (see Fig. 5) weighs w lb. per ft. and has five supports which are L ft. apart. To determine how much of the load each support

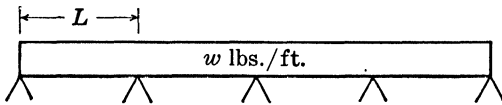

FIG. 5.

bears, it is necessary to solve the following set of equations for the M 's. Determine the M 's.

$$M_1 + 4M_2 + M_3 = -\frac{wL^2}{2},$$

$$M_2 + 4M_3 + M_4 = -\frac{wL^2}{2},$$

$$M_3 + 4M_4 + M_5 = -\frac{wL^2}{2},$$

$$M_1 = 0 \quad \text{and} \quad M_5 = 0.$$

33. A waste mixed acid left over from nitrating is composed of 60.12 per cent H_2SO_4 , 20.23 per cent HNO_3 , and 19.65 per cent H_2O . It is

required to make a mixture of 1,000 lb. containing 60 per cent H_2SO_4 , 22.5 per cent HNO_3 , and 17.5 per cent H_2O . A 97.5 per cent H_2SO_4 (containing 2.5 per cent H_2O) and a 90.5 per cent HNO_3 (containing 9.5 per cent H_2O) are available. How many pounds of each of these two acids and of the waste acid must be used to make up the required mixture if no additional water is to be used? *Solution:* Let W , S , and N denote, respectively, the number of pounds of waste, sulphuric acid, and nitric acid to be used.

$$\begin{array}{rcl} \text{Then} & 1.0000W + 1.0000S + 1.0000N & = 1,000. \\ & 0.6012W + 0.9750S & = 600. \quad (\text{Sulphuric acid}) \\ & 0.2023W & + 0.9050N = 225. \quad (\text{Nitric acid}) \end{array}$$

34. The alternating currents in the circuit shown in Fig. 6 may be found by solving the circuit equations

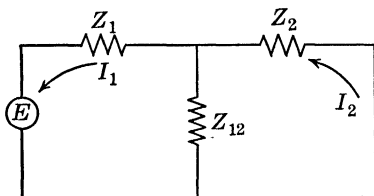

FIG. 6.

$$\begin{array}{l} (Z_1 + Z_{12})I_1 - Z_{12}I_2 = E, \\ -Z_{12}I_1 + (Z_2 + Z_{12})I_2 = 0, \end{array}$$

where E is the impressed voltage, I_1 and I_2 are the currents flowing in the two meshes, and the Z 's are impedances. Obtain literal expressions for the currents and evaluate numerically if $E = 100$ volts,

$Z_1 = 1 + j2$ ohms, $Z_2 = 11 + j2$ ohms, $Z_{12} = 1 + j10$ ohms, where $j = \sqrt{-1}$.

35. A particle moves along a straight line such that its speed v is given in numerical value by

$$v = \omega(r^2 - x^2)^{1/2},$$

where ω is in radians per second, r in feet is the maximum distance the particle moves from a certain center point, and v in feet per second is the speed at a distance x in. from the center point. (x is numerically less than r .) If $v = 90$ in. per sec. when $x = 4$ in., and $v = 80$ in. per sec. when $x = 6$ in., determine the positive values for ω and r . This problem occurs in the study of harmonic motion.

VARIATION

36. The quantity Q of water that will flow each second over a particular type of weir varies directly as the product of the breadth B of the weir and the three-halves power of the head H . If $Q = 160$ cu. ft. per sec. when $B = 6$ ft. and $H = 4$ ft., determine the formula. Then determine Q when $H = 9$ ft. and $Q = 5$ ft.

37. The lift L of the wings of an airplane varies directly as the product of the area A of the wings and the square of the speed V of the plane. If

the wing area is $A = 100$ sq. ft. and the lift is $L = 1,480$ lb. when the speed is $V = 65$ miles per hour, find the formula (use A in feet, L in pounds, and V in miles per hour). If the airplane is exactly doubled in all linear dimensions, what will happen to the weight, to the wing area, and to the lift?

BINOMIAL THEOREM

38. A derivation in fluid mechanics for the quantity of flow of water through a vertical rectangular orifice requires the expansion by the binomial theorem of the two binomial quantities in the following equation and simplification to obtain the second equation. Perform the intermediate steps.

$$\begin{aligned} q &= \frac{2cb}{3} (2g)^{1/2} \left[\left(h + \frac{d}{2} \right)^{3/2} - \left(h - \frac{d}{2} \right)^{3/2} \right] \\ &= (bcd)(2gh)^{1/2} \left(1 - \frac{d^2}{96h^2} - \frac{d^4}{2,048h^4} - \dots \right). \end{aligned}$$

39. The following thermodynamical equation occurs in the study of flow of a gas out of a nozzle:

$$V_{s2} = 223.7 \left\{ cT_1 \left[1 - \left(\frac{p_2}{p_1} \right)^{(k-1)/k} \right] \right\}^{1/2}.$$

a. Evaluate $(p_2/p_1)^{(k-1)/k}$ by the binomial theorem if

$$(1) \left(\frac{p_2}{p_1} \right) = 0.940 \quad \text{and} \quad k = 1.25.$$

$$(2) \left(\frac{p_2}{p_1} \right) = 0.980 \quad \text{and} \quad k = 1.40.$$

b. Write $(p_2/p_1)^{(k-1)/k}$ in the form

$$\left(1 - \frac{p_1 - p_2}{p_1} \right)^{(k-1)/k}$$

and expand to three terms by aid of the binomial theorem. Then simplify $1 - (p_2/p_1)^{(k-1)/k}$ to

$$\frac{k-1}{k} \left[\frac{p_1 - p_2}{p_1} + \frac{1}{2k} \left(\frac{p_1 - p_2}{p_1} \right)^2 + \dots \right].$$

40. In 1879 the American engineers Fteley and Stearns proposed the formula

$$Q = 3.31BH^{3/2} \left(1 + \frac{3h}{2H} \right)^{3/2} + 0.007B$$

for the quantity of water that would flow each second over a certain type of weir. Expand the binomial to two terms and simplify the equation. Then determine $K = Q/(BH^{3/2})$.

41. A study of a certain type of meter in fluid mechanics starts with the equation

$$V_1 = \left\{ 2g \frac{k}{k-1} \frac{p_1}{w_1} \left[\left(\frac{p_2}{p_1} \right)^{(k-1)/k} - 1 \right] \right\}^{1/2}.$$

Show that this equation may be written successively in the following forms:

$$\begin{aligned} \frac{p_2}{p_1} &= \left[\frac{w_1(k-1)}{p_1 k} \frac{V_1^2}{2g} + 1 \right]^{k/(k-1)}, \\ \frac{p_2}{p_1} - 1 &= \left[1 + \frac{w_1(k-1)}{p_1 k} \frac{V_1^2}{2g} \right]^{k/(k-1)} - 1, \\ p_2 - p_1 &= p_1 \left\{ \left[1 + \frac{w_1(k-1)}{p_1 k} \frac{V_1^2}{2g} \right]^{k/(k-1)} - 1 \right\}, \\ &= \frac{w_1 V_1^2}{2g} \left(1 + \frac{w_1}{2p_1 k} \frac{V_1^2}{2g} + \dots \right). \end{aligned}$$

42. (Taken from a text in ceramics.) If b is small, show that an approximate formula for $a = (100)[1 - \sqrt[3]{1 - (b/100)}]$ is $a = b/3$.

43. (Taken from a text on principles of flight of airplanes.) Expand the square root in $Q_g = W[1 - \sqrt{1 - (Q/W)}]$ to three terms and simplify. W is the maximum gross weight of plane and fuel, Q is the maximum fuel load, and Q_g is the permissible quantity of fuel that may be consumed on the outward flight toward an objective.

44. Engineering courses, such as thermodynamics or fluid mechanics, frequently require the computation of such quantities as $(1.045)^{1.41}$; $(0.976)^{1.28}$; $(0.917)^{0.938}$; and $(0.994)^{-1.26}$. Although these can be computed directly by aid of a log log slide rule, the use of the binomial theorem is just as rapid. Moreover, the accuracy by use of the slide rule is limited, whereas that by use of the binomial theorem is not. Compute the values of each of the preceding quantities, each correct to the nearest third decimal.

PROGRESSIONS

45. An automobile makes a trip of K miles from A to B with an average speed of S_1 miles per hour. It makes the return trip with an average speed of S_2 miles per hour. Show that the average speed for the total distance (*i.e.*, that speed which, when multiplied by the total elapsed time, gives the total distance traveled) is the harmonic mean of S_1 and S_2 .

46. A plane travels one-half of a given distance d in miles at a speed of S_1 miles per hour, and the remaining half distance at a speed of S_2 miles per hour. Show that the average speed for the entire distance is the harmonic mean of S_1 and S_2 . Half of this average speed is called the "radius of action per hour" of the plane; *i.e.*, it is the outbound distance that a plane can travel and return from in 1 hr. The "radius of action"

of a plane would be the "radius of action per hour" multiplied by the number of hours in flight.

47. Find the "radius of action" (see Prob. 46) of a plane for a 4-hr. flight when the outgoing ground speed is 80 miles per hour and the incoming speed is 120 miles per hour. Also find the critical time of turning.

48. A plane encounters a changing wind in flying a round trip. On the first half of the outbound flight the head wind is such that the ground speed is only 75 miles per hour, and on the second half it is 100 miles per hour. For the first half of the return flight the speed is 125 miles per

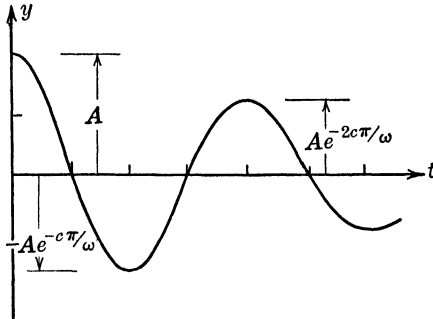

FIG. 7.

hour; for the last half of the return flight the tail wind enables the pilot to make 150 miles per hour.

a. Find the average speed \bar{v} for the entire flight.

b. Compare the total distance traveled in 4 hr. under the conditions stated in the problem with the distance it would travel if the plane traveled for 1 hr. at each of the speeds 75, 100, 125, 150 miles per hour.

49. The current flowing in an electric circuit has the following properties: When time $t = 0$, the current $i = 4$ amp.; when $t = 0.1$ sec., $i = 4e^{-0.2}$ amp.; when $t = 0.2$ sec., $i = 4e^{-0.4}$ amp.; etc. The values of the currents at intervals of 0.1 sec. form a geometric progression.

a. What is the expression for i when $t = 1$ sec.? When $t = 3$ sec.?

b. Determine a general expression for current as a function of time.

50. A ball rolls down an incline 5.47 ft. the first second, 16.41 ft. the second second, and in each succeeding second 10.94 ft. more than in the preceding second. Determine the distance it rolls in the tenth second and the total distance it rolls during the first 10 sec. How far does it roll during the first t sec.?

51. A damped free vibration is shown in Fig. 7 (where displacement is plotted as a function of time). Such a vibration could be a weight vibrating on the end of a spring. The numerical values of the maximum displacements are A , $Ae^{-c\pi/\omega}$, $Ae^{-2c\pi/\omega}$,

a. Show that these values form a geometric progression.

b. Show that the logarithms to the base e of these numbers form an arithmetic progression.

The numerical value of the common difference is called the "logarithmic decrement." This term appears quite frequently in connection with vibration problems. What is its value in this problem?

52. Gravel for a highway is to be hauled from a gravel pit 200 yd. from the highway and at a point opposite one end of a strip to be graveled. Each truck hauling gravel travels this 200 yd. plus the distance already graveled. If one load of gravel suffices for each yard of highway, determine the number of miles traveled by the highway trucks in graveing 2 miles of highway. How much distance for x miles of highway?

THEORY OF EQUATIONS

53. If a solid sphere of radius R and made of material with a specific gravity s ($s < 1$) is placed in water, it will float. The depth (h in.) of the part of the sphere under water is such that the weight of the solid sphere is equal to the weight of the water displaced. Given, from solid geometry, that the volume of a spherical segment of height h is

$$V = \frac{\pi h^2}{3} (3R - h),$$

show that h is a solution of the equation $\frac{\pi h^2}{3} (3R - h) = \frac{4\pi R^3 s}{3}$.

If $R = 4$ in. and $s = 0.70$, compute the value of h correct to the nearest 0.01 in.

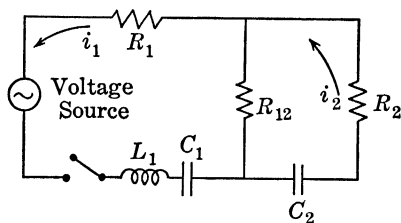

FIG. 8.

54. The two-mesh electric circuit shown in Fig. 8 has the following data:

$$\begin{aligned} R_1 &= 10 \text{ ohms,} & R_{12} &= 5 \text{ ohms,} & R_2 &= 3 \text{ ohms,} \\ L_1 &= 0.01 \text{ henry,} & C_1 &= 0.000,001 \text{ farad,} \\ C_2 &= 0.000,000,5 \text{ farad.} \end{aligned}$$

To determine the currents after the switch is closed it is necessary to solve the following algebraic equation:

$$L_1(R_2 + R_{12})w^3 + \left(R_1R_2 + R_1R_{12} + R_2R_{12} + \frac{L_1}{C_2} \right) w^2 + \left(\frac{R_2}{C_1} + \frac{R_{12}}{C_1} + \frac{R_1}{C_2} + \frac{R_{12}}{C_2} \right) w + \frac{1}{C_1C_2} = 0,$$

which, for the given data, becomes

$$0.08w^3 + 20,095w^2 + 38,000,000w + 2,000,000,000 = 0.$$

Show that this equation has one real root $w = \alpha$ and find it correct to the nearest three significant figures. Then divide by $w - \alpha$ and neglect the remainder. Use the resulting quadratic to determine the two complex roots.

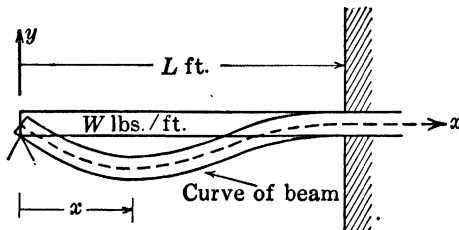

FIG. 9.

55. Figure 9 shows a beam that is built in at one end and simply supported at the other end. To determine the horizontal distance to the lowest point on the curve, it is necessary to solve the equation $8x^3 - 9Lx^2 + L^3 = 0$. The figure shows that the desired value of x is approximately $0.4L$. Determine this value of x , correct to the nearest three significant figures. Notice that the equation has one rational root.

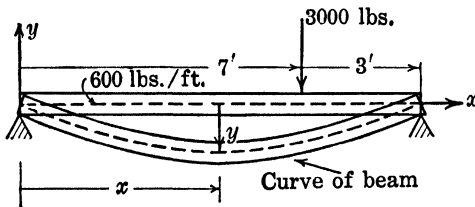

FIG. 10.

56. To find the maximum deflection y for the beam shown in Fig. 10 it is necessary first to solve the equation

$$-100x^3 + 1,950x^2 - 38,650 = 0$$

for its root between $x = 0$ and $x = 7$. Find this root correct to the nearest three significant figures.

57. The formula $d^5 = Ad + B$ is used to find the diameter d in. of a pipe that will discharge a given quantity of water per second. A and B are known constants. If $A = 15.5$ and $B = 400$, compute the value of d correct to three significant figures by the following method:

To obtain a first estimate for the value of d , neglect the term Ad and solve $d^5 = 400$ for d . Substitute this value in $Ad + B$ and then determine a second estimate for d from d^5 equated to this computed value. Continue this process until the value for d does not change in the third significant figure.

This is a method of practical approximation that is especially suited to the use of a slide rule. This method frequently can be used on a cubic equation if one first transforms the equation (by a proper reduction in the size of the roots) so that the quadratic term is missing.

58. The amount of water (q cu. ft. per sec.) that flows over a trapezoidal spillway is given by

$$q = \frac{2}{15} \sqrt{2g} (5b + 4z)(H^{3/2}),$$

where $g = 32.2$ ft. per sec. per sec., b is the width of the bottom of the trapezoid, and the width at the top is $b + 2z$. The depth of the water is H ft.

If $z = H/4$, $b = 6$ ft., $q = 400$ cu. ft. per sec., determine the proper value of H correct to the nearest three significant figures. For a "cut-and-try" method, show that the equation can be written in the form $H^{3/2} = 93.46/(30 + H)$.

59. The equation $q = 0.622 \sqrt{2g} (b - 0.2h)(h^{3/2})$ is used to determine the quantity of water (q cu. ft. per sec.) that flows each second over a rectangular weir of width b ft. when the head (height of water source above that flowing over the weir) is h ft. If $q = 24.4$ cu. ft. per sec. and $b = 3.00$ ft., compute the value of h correct to three significant figures. You may use either the methods explained in your text on college algebra or the following cut-and-try method. For a first approximation, solve for h in $q = (0.622)(2g)^{1/2}(b)(h^{3/2})$. Substitute this value for h in the expression $b - 0.2h$ and again solve for h . Continue this sequence of steps until the computed value for h does not change in the third significant figure.

60. A hollow iron sphere has an external radius of 2 ft. What wall thickness should the sphere have so that the sphere will just float in water? Iron weighs approximately 7.8 times as much as water. *Suggestion:* The weight of a solid sphere of iron of radius 2 ft. less the weight of a solid sphere of radius $2 - t$ ft. = weight of a solid sphere of water of radius 2 ft.

61. A design problem in chemical engineering led to the following question: A right circular cone has an altitude of 10 in. and radius of base 6 in. It is required to inscribe a right circular cylinder whose

volume will be one-third the volume of the cone. What are the dimensions of the cylinder?

62. (Taken from a text on vibrations.) Determine the exact values of the roots of the equation

$$4F^3 - 10F^2 + 6F - 1 = 0.$$

63. The following equations are solved in a text on vibration problems in engineering. Obtain all the solutions, each correct to the nearest three significant figures:

(a) $x^3 - 407x^2 + 34,492x - 296,230 = 0.$

(b) $p^6 - 6\beta p^4 + 10\beta^2 p^2 - 4\beta^3 = 0.$

(c) $p^4 - 106,000p^2 + 2,060,000,000 = 0.$

(d) $10^{-21}\omega^6 - 3.76(10^{-14})\omega^4 + 1.93(10^{-7})\omega^2 - 0.175 = 0.$

Remarks: Two of the preceding problems suggest cut-and-try methods for the determination of irrational roots. In many engineering problems an accuracy of three significant figures is quite sufficient, and the required roots can be obtained rapidly by aid of a slide rule. Certain types of problems lead to algebraic equations that can be solved rapidly by special methods. For example:

If the quartic equation with four complex roots

$$a_0w^4 + a_1w^3 + a_2w^2 + a_3w + a_4 = 0$$

arises from an electric-circuit problem in which the resistances are small or from a vibration problem in which damping is small, then one can neglect the terms of odd degree and determine satisfactory estimates for the imaginary parts of the complex roots. The real parts may then be determined by relations between the coefficients and roots.

It is worth noting that, although the Horner method itself does not appear very much in engineering literature, many of the ideas which the student learns in the chapter on the theory of equations do appear in other circumstances.

The standard method for computing complex roots is Graeffe's root-squaring method, which is explained in advanced mathematics and engineering texts.

DETERMINANTS AND SIMULTANEOUS LINEAR EQUATIONS

64. In an analysis of a class *A* radio amplifier a derivation of a so-called "load line" requires that the three equations

$$i_b = I_b - i_p, \quad e_b = E_b + e_p, \quad e_p = i_p R_L$$

be combined to obtain the equation

$$e_b = E_b + R_L(I_b - i_b).$$

Perform the required algebra to obtain this last equation.

65. By applying Ohm's and Kirchhoff's laws to the three-mesh electric circuit, which contains resistances (in ohms) as shown in Fig. 11, the following set of equations is obtained:

$$\begin{aligned} 4I_1 - 2I_2 - I_3 &= E_1, \\ -2I_1 + 14I_2 - 3I_3 &= E_2, \\ -I_1 - 3I_2 + 6I_3 &= E_3. \end{aligned} \quad \left(\begin{array}{l} R_1 = 1 \text{ ohm}, R_2 = 9 \text{ ohms} \\ R_3 = 2 \text{ ohms}, R_{12} = 2 \text{ ohms} \\ R_{13} = 1 \text{ ohm}, R_{23} = 3 \text{ ohms} \end{array} \right)$$

a. Determine the currents I_1, I_2, I_3 (in amperes) flowing in each mesh of the circuit if $E_1 = 10$ volts, $E_2 = 5$ volts, and $E_3 = 2$ volts.

b. Compute I_1 if $E_1 = E_3 = 0$ and $E_2 = E$. Also compute I_2 if $E_2 = E_3 = 0$ and $E_1 = E$. Show that the results are the same in both cases.

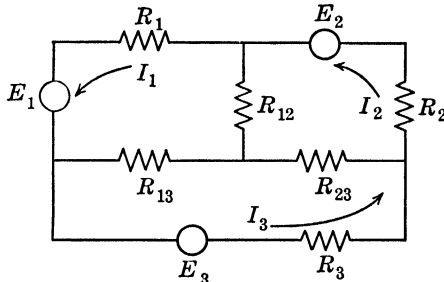

FIG. 11.

c. Solve the three equations simultaneously for the I 's in terms of the E 's.

Remarks: The literal equations for the given network are as follows:

$$\begin{aligned} (R_1 + R_{12} + R_{13})I_1 - R_{12}I_2 - R_{13}I_3 &= E_1, \\ -R_{12}I_1 + (R_2 + R_{12} + R_{23})I_2 - R_{23}I_3 &= E_2, \\ -R_{13}I_1 - R_{23}I_2 + (R_3 + R_{13} + R_{23})I_3 &= E_3. \end{aligned}$$

The answer to question *c* can be interpreted as saying that the same currents I_1, I_2, I_3 would flow in a three-mesh electric circuit as shown in Fig. 11 with the following data: $R_{12} = R_{13} = R_{23} = 0$, $R_1 = R_2 = R_3 = 1$ ohm, $E_1' = 0.3E_1 + 0.06E_2 + 0.08E_3$ volts, $E_2' = 0.06E_1 + 0.092E_2 + 0.056E_3$, $E_3' = 0.08E_1 + 0.056E_2 + 0.208E_3$.

66. In a five-mesh electric circuit similar to the one in the preceding problem, it is shown in electrical engineering courses that the currents I_1, I_2, I_3, I_4 , and I_5 satisfy equations of the following form:

$$\begin{aligned} a_1I_1 + a_2I_2 + a_3I_3 + a_4I_4 + a_5I_5 &= E_1, \\ a_2I_1 + b_2I_2 + b_3I_3 + b_4I_4 + b_5I_5 &= E_2, \\ a_3I_1 + b_3I_2 + c_3I_3 + c_4I_4 + c_5I_5 &= E_3, \\ a_4I_1 + b_4I_2 + c_4I_3 + d_4I_4 + d_5I_5 &= E_4, \\ a_5I_1 + b_5I_2 + c_5I_3 + d_5I_4 + e_5I_5 &= E_5. \end{aligned}$$

a. Indicate the solution for I_1 and for I_3 by the use of fifth-order determinants. Do not expand.

b. By the theory of determinants, show that the solution for I_1 when $E_3 = E$ and all the other E 's are zero is the same as the solution for I_3 when $E_1 = E$ and all the other E 's are zero.

c. Show that the solution for I_1 in terms of the E 's can be obtained as follows: Let I_{11} denote the value of I_1 when $E_1 = 1$ volt and all the other E 's are zero. Let I_{12} denote the value of I_1 when $E_2 = 1$ volt and all the other E 's are zero. Let I_{13}, I_{14}, I_{15} have similar definitions. Then the required solution for I_1 in terms of the E 's is given by

$$I_1 = E_1 I_{11} + E_2 I_{12} + E_3 I_{13} + E_4 I_{14} + E_5 I_{15}$$

Remark: This problem suggests two theorems about electric circuits, which will be proved in senior courses in electrical engineering.

67. The Wheatstone bridge shown in Fig. 12 is a circuit for measuring a resistance R_4 in terms of three known resistances $R_1, R_2,$ and R_3 . G is a galvanometer of resistance R_g . E is the impressed battery voltage. The currents satisfy the equations:

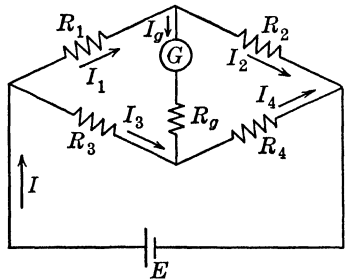

FIG. 12.

$$\begin{aligned} I_1 - I_g - I_2 &= 0, & I_3 + I_g - I_4 &= 0, & I - I_3 - I_1 &= 0, \\ R_1 I_1 + R_2 I_2 - R_3 I_3 - R_4 I_4 &= 0, \\ R_1 I_1 + R_g I_g - R_3 I_3 &= 0, & R_1 I_1 + R_2 I_2 &= E. \end{aligned}$$

a. Show that if $R_1 R_4 = R_2 R_3$ then $I_g = 0$.

b. Obtain an expression for I_g if $E = 10$ volts, $R_1 = 100$ ohms, $R_2 = 1,000$ ohms, $R_3 = 201$ ohms, $R_4 = 2,000$ ohms, and $R_g = 1,000$ ohms.

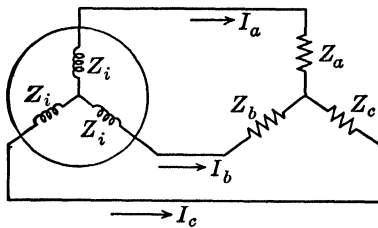

FIG. 13.

68. The current supplied by a "three-phase alternator" to an "unbalanced load" may be obtained by solving the simultaneous equations:

$$\begin{aligned} (Z_i + Z_a)I_a - (Z_i + Z_b)I_b &= E_{ba}, \\ (Z_i + Z_b)I_b - (Z_i + Z_c)I_c &= E_{cb}, \\ I_a + I_b + I_c &= 0, \end{aligned}$$

in which Z_i is the internal impedance of the alternator; $Z_a, Z_b,$ and Z_c are the load impedances; and E_{ab} and E_{cb} are the generated voltages between two pairs of terminals, as shown in Fig. 13.

Solve for the currents I_a, I_b, I_c first in literal form and then in numerical form for the following data: $Z_i = 1 + j10$ ohms, $Z_a = 20 + j15$ ohms, $Z_b = 40 + j30$ ohms, $Z_c = 60 + j0$ ohms, $E_{ba} = 866 + j500$ volts, $E_{cb} = -j1,000$ volts, and $j = \sqrt{-1}$.

69. A beam weighs 1,000 lb. per ft. and has six supports as shown in Fig. 14. To determine how much of the load each support bears, it is

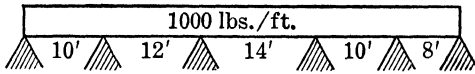

FIG. 14.

necessary to solve the following set of equations for the M 's. Give the final results correct to the nearest three significant figures.

$$\begin{aligned} 11M_2 + 3M_3 &= -170,500, \\ 6M_2 + 26M_3 + 7M_4 &= -559,000, \\ 7M_3 + 24M_4 + 5M_5 &= -468,000, \\ 5M_4 + 16M_5 &= -189,000. \end{aligned}$$

70. A ladder leans against a wall as shown in Fig. 15. There is some friction between the ladder and the floor and between the ladder and the wall. A problem in mechanics would be to determine the value of the force P that would cause the ladder to be on the verge of moving up the wall.

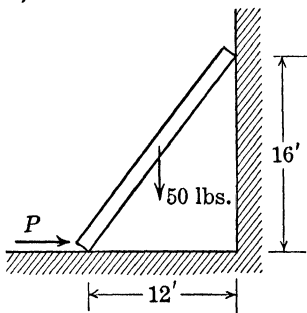

FIG. 15.

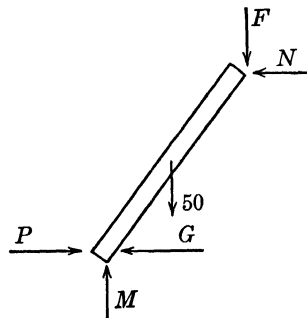

FIG. 16.

From Fig. 16, one learns in mechanics how to write down the following simultaneous equations. Solve them for P .

$$\begin{aligned} P - G - N &= 0, & M - 50 - F &= 0, & -12F + 16N - 300 &= 0, \\ & & 4F &= N, & 2G &= M. \end{aligned}$$

71. Three 1-oz. balls are strung on a string of length 4 ft. and tied as indicated in Fig. 17. The string is pulled taut and tied to stationary vertical boards. The string is then pulled vertically upward a short

distance and released so that the three balls will oscillate in a vertical direction. Let y_1 be the vertical distance from the horizontal to the first ball, y_2 for the second ball, and y_3 for the third ball (Fig. 18). By methods of mechanics one can obtain the following three equations, which are valid at a particular time after the balls are released:

$$\begin{aligned} (3 - 4F)y_1 + 2y_2 + y_3 &= 0, & y_1 + 2(1 - F)y_2 + y_3 &= 0, \\ y_1 + 2y_2 + (3 - 4F)y_3 &= 0, \end{aligned}$$

where F depends on the weight of the balls, their distances apart, how tight the string was originally stretched, etc. For most values of F , these equations will have only the simultaneous solution:

$$y_1 = y_2 = y_3 = 0,$$

which means that after a short time the balls would come to rest. But

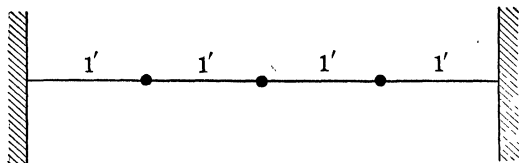

FIG. 17.

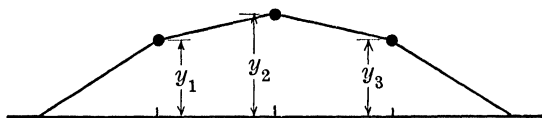

FIG. 18.

for three special values for F , these equations have other solutions than the preceding one.

Determine these three values for F and then find the solutions y_1 , y_2 , y_3 for each of these values for F and on the assumption that $y_1 = 1$ unit. Then plot the string and balls for each of these three solutions.

Remark: Actually, the vertical displacements vary with time according to the form $y = y_k \sin \omega t$.

***72.** Suppose that a body falls in a vacuum from an original height s_0 ft. and with an initial speed of v_0 ft. per sec. The distance (s ft.) that the body will fall during the first t sec. will then conceivably depend on t , s_0 , v_0 , the acceleration due to gravity g ft. per sec. per sec., and the weight of the body W lb. Expressed mathematically, we can say that s is some function of these quantities; *i.e.*,

$$s = F(t, v_0, s_0, g, W).$$

Now suppose that this function can be expressed as the sum of terms each of which is a product of powers of the separate variables. Then each term will be of the form:

$$(t)^a(v_0)^b(s_0)^c(g)^d(W)^e.$$

Since the left-hand member of the original equation, s , has the dimension of feet, each of the terms on the right-hand side must have the dimension of feet. Thus, substituting the dimensions for each factor, we obtain

$$(T)^a \left(\frac{L}{T}\right)^b (L)^c \left(\frac{L}{T^2}\right)^d (W)^e \equiv L,$$

where $W \equiv$ force, $L \equiv$ length, and $T \equiv$ time.

For this to be an identity we must have

$$b + c + d = 1, \quad a - b - 2d = 0, \quad e = 0.$$

Problem: Solve the first two equations for a and d in terms of b and c . Then show that the following sets of five numbers are solutions of the preceding three equations:

a	b	c	d	e
2	0	0	1	0
1	1	0	0	0
0	0	1	0	0

Notice that $e = 0$ means that the distance is independent of the weight of the body.

The conclusion that one could then make is that every term in the expansion of the given function is a combination of the three terms t^2g , tv_0 , and s_0 , each of which has the dimension of feet. The simplest combination of these would be to try $s = A(t^2g) + B(tv_0) + C(s_0)$. There is no justifiable reason for this, save as a trial. If you took this formula to the laboratory to see if it could be true and, if so, determined the values for A , B , and C , you would obtain $s = (gt^2/2) + v_0t + s_0$.

73. Determine x , y , and z in terms of n so that the following will be an identity:

$$\frac{W}{LT^2} \equiv (L)^x \left(\frac{W}{L^3}\right)^y \left(\frac{W}{LT}\right)^z \left(\frac{L}{T}\right)^n.$$

This problem arises in fluid mechanics, in much the same manner as Prob. 72, as a result of a study of pipe friction.

74. The theoretical analysis of a damped vibration absorber on a machine requires the simultaneous solution of the following pair of equations ($j = \sqrt{-1}$):

$$\begin{aligned} (-M\omega^2 + K + k + j\omega c)x_1 - (k + j\omega c)x_2 &= P, \\ -(k + j\omega c)x_1 + (-m\omega^2 + k + j\omega c)x_2 &= 0. \end{aligned}$$

Indicate the solutions for x_1 and x_2 by means of determinants. Notice that the solutions are both in complex-number form. Determine the absolute value for the complex number solution for x_1 . Thus, if $x_1 = a + jb$, you are to determine the value of $(a^2 + b^2)^{1/2}$.

Remarks: Determinants are used in engineering in the following ways:

1. An important aid in proofs of theorems.
2. A method of obtaining "formulas" for the simultaneous solutions. These formulas are convenient if the coefficients are complex numbers.
3. A convenient method for manipulating operational expressions such as are met in the solution of simultaneous linear differential equations and in problems such as number 74.

75. An algebraic equation is said to be "stable" if its real roots are all negative and its complex roots all have negative real parts. It can be shown that the quartic equation

$$a_0x^4 + a_1x^3 + a_2x^2 + a_3x + a_4 = 0, \quad a_0 \text{ positive,}$$

is stable if the values of each of the following determinants are positive:

$$\begin{array}{cccc} |a_1|, & \begin{vmatrix} a_1 & a_0 \\ a_3 & a_2 \end{vmatrix}, & \begin{vmatrix} a_1 & a_0 & 0 \\ a_3 & a_2 & a_1 \\ 0 & a_4 & a_3 \end{vmatrix}, & \begin{vmatrix} a_1 & a_0 & 0 & 0 \\ a_3 & a_2 & a_1 & a_0 \\ 0 & a_4 & a_3 & a_2 \\ 0 & 0 & 0 & a_4 \end{vmatrix}. \end{array}$$

a. Test for stability in the following equation taken from a text on vibrations: $x^4 + 8x^3 + 10x^2 + 5x + 7 = 0$.

b. Test for stability: $x^4 + 4x^3 + 6x^2 + 5x + 2 = 0$. Then show that there are two rational roots, determine all four roots, and verify the definition of stability from the roots themselves.

PART II

TRIGONOMETRY

FUNDAMENTAL IDENTITIES

76. In the magazine *Electrical Engineering* (vol. 52, 1933, p. 724) is given a short cut for finding the value of $\sqrt{a^2 + b^2}$. The method is as follows: Assume that $a > b$. Rewrite the given expression in the form $a\sqrt{1 + (b/a)^2}$. Determine the acute angle θ if $\tan \theta = b/a$. The value of the given expression can be found by dividing a by $\cos \theta$ or by multiplying a by $\sec \theta$. Prove that this is a correct method.

77. Let two wattmeter readings for a particular electric circuit be w_1 and w_2 . Then the so-called "power factor" for the problem can be determined from these wattmeter readings by aid of the equation

$$\tan \theta = \frac{\sqrt{3}(w_2 - w_1)}{w_2 + w_1} = \frac{\sqrt{3}d}{s}.$$

Show that $\cos \theta = 1/[1 + 3(d/s)^2]^{1/2}$.

78. The follower on a cam at a time t sec. has for its abscissa

$$x = 5 \sin 2\pi\omega t \text{ in.}$$

and for its ordinate $y = 4 \cos 2\pi\omega t$ in. The quantity ω is a constant. Show that $x^2/25 + y^2/16$ always has the value +1, irrespective of the time.

79. It is necessary to make a table of values of the function

$$\frac{x}{(16 - 9x^2)^{1/2}}$$

for $x = 0, 0.1, 0.2, \dots, 1.3$. Show that this computation may be accomplished readily by replacing $3x$ by $4 \sin \theta$ and then simplifying the given expression to $\frac{1}{3} \tan \theta$. Make up the table of required values correct to four decimals.

RIGHT TRIANGLES

80. A weight of 50 lb. is suspended at the free end of a horizontal bar, which is pivoted at the left end and is held in position by a cord that makes an angle of 20° with the horizontal (Fig. 19). Determine the tension in the cord (T lb.) and the tension in the bar (P lb.) from the triangle of forces (Fig. 20).

81. Three forces of 60, 90, and 100 lb. act at angles 45° , 150° , and 210° , respectively, with the horizontal (Fig. 21).

a. Determine the x and y components of each force.

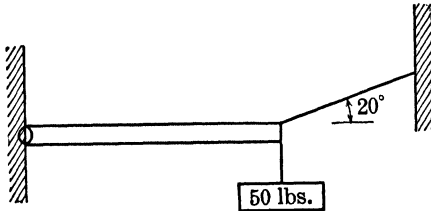

FIG. 19.

b. Determine the sum of all three x components and the sum of all three y components.

c. Determine the resultant of these total x and y components. Give the result both in magnitude and direction.

82. Three forces of 61.2, 93.8, and 106 lb. act, respectively, at angles 51.2° , 145.1° , and 281.3° with the horizontal.

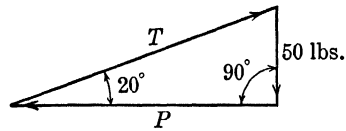

FIG. 20.

a. Determine the horizontal and vertical components of each force, each correct to slide-rule accuracy.

b. Determine the sum of the horizontal components and the sum of the vertical components.

c. Determine the resultant (in magnitude and direction) of the total horizontal and total vertical components.

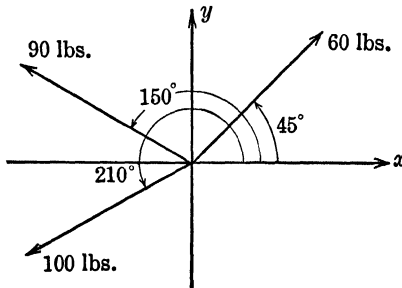

FIG. 21.

83. Because of "centrifugal force" a man on a bicycle going around a curve will tend to lean at an angle θ , which depends on his weight, his speed, and the radius of the circular curve around which he is moving. If the combined weight of the man and bicycle is 200 lb. and if he is going around a curve of 60 ft. radius at a speed of 15 ft. per sec., then

the centrifugal force is 23.3 lb. Use Fig. 22 to determine the angle θ at which he should lean.

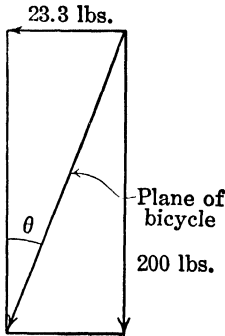

FIG. 22.

84. An airplane weighs 9,000 lb. and is climbing at an angle of 5.00° . Compute the components of the weight of the airplane in the line of flight and perpendicular to this line. Give results to three significant figures.

85. Two balls hang by cords as shown in Fig. 23. The length of each cord is 2 meters and the weight of each ball is 0.5 gram. A charge of $5(10^{-6})$ coulombs is placed on each ball. A question asked in a course in electrical engineering fundamentals was to determine the angle θ between the cords, assuming that the cords are straight. The solution of the problem shows that

the angle θ must be such that

$$\tan \frac{\theta}{2} = 11.5d^{-2}.$$

Start with this equation and show, by aid of Fig. 23, that d must be a solution of the equation

$$4d^6 + 529d^2 = 2,116.$$

Then solve this equation correct to the nearest two significant figures.

86. Two poles are 42 ft. apart. One is 30 ft. tall and the other is 24 ft. tall. A 48-ft. cable is fastened to the top of each pole and the cable supports a weight of 400 lb., which hangs from it by a trolley. When the trolley comes to rest, the figure is as shown in Fig. 24 (assuming that the two pieces of the cable are straight).

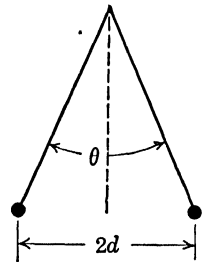

FIG. 23.

The sum of the x components (in Fig. 25) must be zero and the algebraic sum of the y components must also be zero.

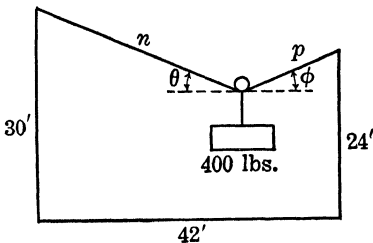

FIG. 24.

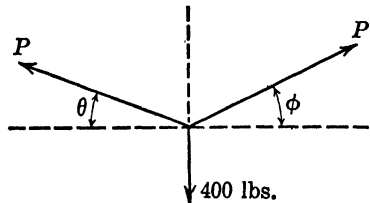

FIG. 25.

Hence,
and

$$P \cos \theta = P \cos \varphi,$$

$$P \sin \theta + P \sin \varphi = 400.$$

From the geometry of Fig. 24: $n + p = 48$,

$$n \cos \theta + p \cos \varphi = 42,$$

$$n \sin \theta - p \sin \varphi = 30 - 24 = 6.$$

Verify these five equations and solve them simultaneously for the acute angles θ and φ , the lengths n and p ft., and the tension in the cable P lb.

87. A cord whose length is $2L$ ft. is fastened at A and B (Fig. 26) in the same horizontal line; the two points A and B are $2a$ ft. apart. A

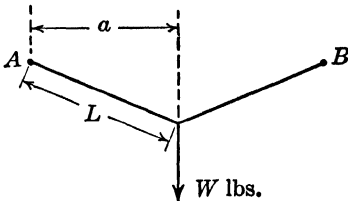

FIG. 26.

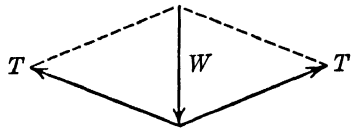

FIG. 27.

smooth ring on the cord is attached to a weight of W lb. (see Fig. 27). Show that the tension in the cord ($a < L$) is

$$T \text{ lb.} = \frac{WL}{2(L^2 - a^2)^{1/2}}.$$

88. A condenser having "capacitive reactance" of 10 ohms, a resistance of 12 ohms, and an air coil with an "inductive reactance" of 16 ohms are all connected in series. Determine the "impedance" (Z ohms) and the power factor ($\cos \theta$) for the circuit. Also determine the angle θ correct to the nearest minute (see Fig. 28).

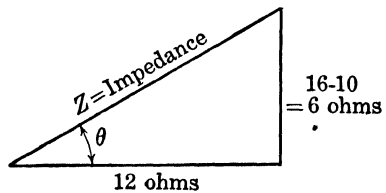

FIG. 28.

If this series circuit is connected to a 60-cycle, $E = 100$ volt, a.c. source, and the current $I = 100/Z$ (amperes), calculate I and

$$P = EI \cos \theta \text{ watts,}$$

each correct to the nearest three significant figures.

OBLIQUE TRIANGLES

Note: Trigonometry texts abound in good examples of the use of oblique triangles in engineering. The following few problems are thought to be somewhat different and are included for that reason.

89. An airplane flies from point A on a track due east (90° track). The wind is 30 miles per hour from 240° track and the air speed of the airplane is 105 miles per hour.

a. In Fig. 29, find the angle θ .

b. Find the heading of the airplane (the angle measured from the north which the forward axis of the airplane makes with that direction) by adding θ to 90° in this particular problem.

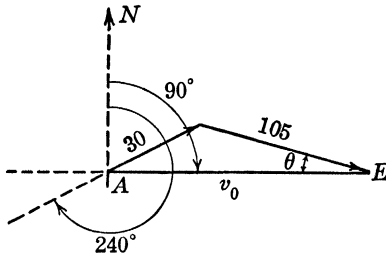

FIG. 29.

c. Determine the ground speed of the airplane v_0 . The ground speed is the vector sum of the speed of the airplane relative to the air plus the speed of the wind relative to the ground.

90. What are the answers to the three questions in Prob. 89 if the airplane flies due west?

91. In Prob. 89, a second airplane leaves point P located 90 miles southeast (bearing of 225° track) from A at the same time as the airplane at A and has an air speed of 150 miles per hour. The wind conditions remain the same as in Prob. 89.

a. If θ is the angle between the air-speed vector of airplane P and the horizontal and if t is the time required for airplane P to intercept airplane A show that

$$\begin{aligned} 150t \cos \theta + 30t \cos 30^\circ &= 90 \cos 45^\circ + 130t, \\ 150t \sin \theta + 30t \sin 30^\circ &= 90 \sin 45^\circ. \end{aligned}$$

Solve for t and θ , and finally for the direction of the track of airplane P .

92. In Fig. 30 w represents a constant wind speed making an angle θ with the track of an airplane along which the ground speeds S_1 and S_2 (outbound and incoming speeds) are attained by an airplane of constant air speed v .

a. Show, from the figure, that

$$\begin{aligned} S_1 &= w \cos \theta + v \cos \varphi, \\ S_2 &= v \cos \varphi - w \cos \theta, \\ w \sin \theta &= v \sin \varphi. \end{aligned}$$

b. Show that the product $S_1 S_2$ is a constant (note that w and v are assumed to be constant).

c. Show that

$$\frac{S_1 S_2}{S_1 + S_2} = \frac{v^2 - w^2}{2 \sqrt{v^2 - w^2 \sin^2 \theta}}.$$

d. Show that for a wind of any given speed the "radius of action" (see Prob. 46)

$$R = \frac{S_1 S_2}{S_1 + S_2}$$

is least for a head-tail wind ($\theta = 0^\circ$) and greatest for a wind at right angles to the track ($\theta = 90^\circ$).

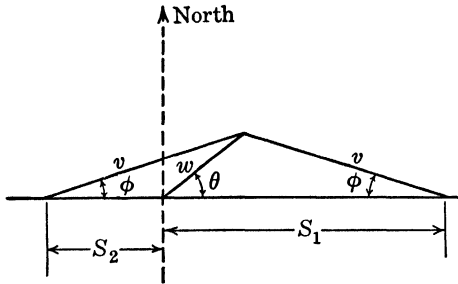

FIG. 30.

MULTIPLE ANGLE IDENTITIES

93. A sphere weighing W lb. rests between two smooth planes, as shown in Fig. 31. Figure 32 shows the weight of the sphere and the forces that the two planes exert upon the sphere. Since the algebraic

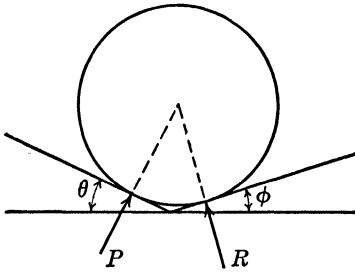

FIG. 31.

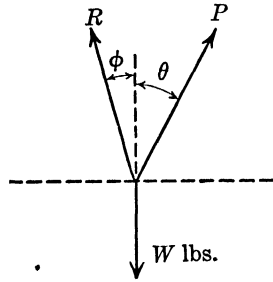

FIG. 32.

sum of the horizontal components of the forces must be zero and the algebraic sum of the vertical forces must likewise be zero, we obtain

$$\begin{aligned} R \sin \varphi - P \sin \theta &= 0, \\ R \cos \varphi + P \cos \theta &= W. \end{aligned}$$

Solve these two equations simultaneously for R and P in terms of W , θ , and φ and show that your results can be put in the form

$$P = \frac{W \sin \varphi}{\sin (\theta + \varphi)}, \quad R = \frac{W \sin \theta}{\sin (\theta + \varphi)}.$$

94. The period of vibration of a pendulum is given by the approximate formula

$$T = 2\pi \left(\frac{L}{g}\right)^{\frac{1}{2}} \left(1 + \frac{1}{4} \sin^2 \frac{\theta}{2} - \frac{9}{64} \sin^4 \frac{\theta}{2}\right)$$

which is much more accurate than the one customarily given in an elementary course in physics, namely, $T = 2\pi(L/g)^{\frac{1}{2}}$. L is the length of the pendulum and $g = 32.2$ ft. per sec. per sec. θ is the angle that the pendulum makes with the vertical at the instant it is released.

a. Evaluate the part in parentheses for $\theta = 2^\circ, 30^\circ, 60^\circ$.

b. Show that the quantity in parentheses can be written in the following form: $1 + \frac{3}{8} \sin^2 \frac{\theta}{2} - \frac{9}{64} \sin^4 \frac{\theta}{2}$.

95. The voltage in an electric circuit is

$$e = 40 \sin 120\pi t + 5 \sin 360\pi t \text{ volts.}$$

The current is

$$i = 4 \sin 120\pi t + 2 \sin 360\pi t \text{ amp.}$$

Determine an expression for the power $p = e \cdot i$ watts and leave your final result in a form free of powers and products of trigonometric functions.

96. Two voltages:

$$e_1 = 40 \sin \left(120\pi t + \frac{\pi}{3}\right) \text{ volts,}$$

$$e_2 = 60 \sin \left(120\pi t - \frac{\pi}{4}\right) \text{ volts,}$$

are simultaneously impressed in series on an electric circuit. Combine these into a single voltage by performing the operation $e = e_1 + e_2$. Give your final result in the form $E \sin (120\pi t + \theta)$.

97. If the voltage in an electric circuit is

$$e = E_m \sin \alpha$$

and the current is

$$i = I_m \sin (\alpha + \theta),$$

show that the power, $p = e \cdot i$ watts, can be expressed in the form

$$p = \left(\frac{E_m I_m}{2}\right) [\cos \theta - \cos (2\alpha + \theta)].$$

Remark: This derivation is to be found in every text on a.c. circuits.

98. The value of the voltage e in volts due to "amplitude modulation" is given by

$$e = 100(1 + 0.7 \cos 4,000t - 0.3 \cos 8,000t) \sin 4,000,000t$$

where t is in seconds. Show that this can be rewritten in a form free

of products of trigonometric functions, *i.e.*, as the sum of simple sine functions. Then determine the amplitude, period, and frequency for each of the resulting terms.

*99. Figure 33 shows a connecting rod, crank-arm mechanism from an engine.

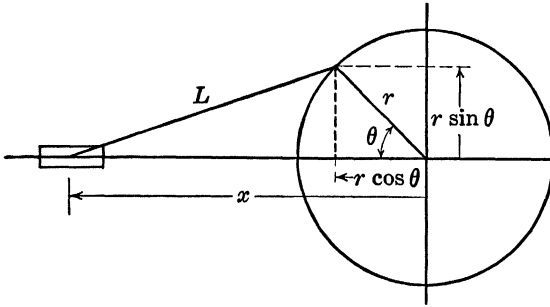

FIG. 33.

a. Show that

$$\begin{aligned} x &= r \cos \theta + (L^2 - r^2 \sin^2 \theta)^{\frac{1}{2}} \\ &= r \cos \theta + L \left(1 - \frac{r^2}{L^2} \sin^2 \theta \right)^{\frac{1}{2}}. \end{aligned}$$

b. Expand the binomial to four terms by aid of the binomial theorem and obtain

$$x = r \cos \theta + L - \frac{r^2 \sin^2 \theta}{2L} - \frac{r^4 \sin^4 \theta}{8L^3} - \frac{r^6 \sin^6 \theta}{16L^5} - \dots$$

c. Transform this expression so that there are no powers of trigonometric functions present and show that the result is

$$\begin{aligned} x &= \left(L - \frac{r^2}{4L} - \frac{3r^4}{64L^3} - \frac{5r^6}{256L^5} - \dots \right) + r \cos \theta \\ &\quad + \cos 2\theta \left(\frac{r^2}{4L} + \frac{r^4}{16L^3} + \frac{13r^6}{512L^5} + \dots \right) \\ &\quad - \cos 4\theta \left(\frac{r^4}{64L^3} + \frac{3r^6}{256L^5} + \dots \right) + \dots \end{aligned}$$

d. Simplify the preceding expression if $L/r = 5$.

e. What would this last result be if you used only the first two terms of the binomial expansion?

Remark: The result in (e) is commonly used in engineering problems, since the coefficients of the higher harmonics are small ($L/r \geq 5$). However, there are times when it is necessary to know something about the higher harmonics, and you obtained some of them in this problem.

GRAPHS OF THE TRIGONOMETRIC FUNCTIONS. LINE VALUES¹

100. If a voltage is described as having a sinusoidal wave form, a maximum value of 140 volts, and an angular velocity of 377 radians per second (60 cycles per second), and if it is agreed to determine time from a point of zero voltage where the slope of the tangent line to the curve is positive, the mathematical equation for the alternating voltage as a function of time is

$$e = 140 \sin 377t \text{ volts.}$$

Compute the voltages at $t = 0.001$ sec. and $t = 0.002$ sec. Sketch the voltage wave for several cycles.

101. A voltage in an electric circuit is $e = 140 \sin 377t$ volts and the current is $i = 7.07 \sin 377t$ amp. If the power is

$$p = e \cdot i = 500(1 - \cos 754t),$$

sketch on the same graph the voltage wave, current wave, and power wave.

102. At a certain instant the voltage in an electric circuit is represented by the vector e volts as shown in Fig. 34. At that same instant

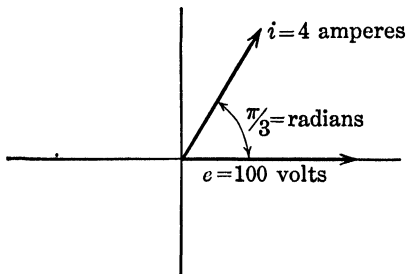

FIG. 34.

the current i amp. is likewise shown as a vector. Let both vectors rotate together in a counterclockwise direction at 60 cycles per second or 120π radians per second. Sketch a graph showing time as abscissa and the vertical projections of these two vectors as ordinates. Show the graph for several cycles. Notice on your resulting graph that the current always *leads* the voltage by 60° or $\pi/3$ radian. Also show that the equations of the two curves are $e = 100 \sin 120\pi t$, $i = 4 \sin (120\pi t + 60^\circ)$.

103. The piston of an engine transmits a force of $F = 100 \sin 30\pi t$ lb. Plot a graph of force as a function of time.

104. The approximate tide curve for Cape Cod Bay is

$$h = h_m \sin \left(\frac{2\pi t}{T} \right)$$

¹ For other problems on graphs of the trigonometric functions, see Part III.

where $h_m = 6$ ft. and $T = 44,715$ sec. Plot h as a function of time t sec.

TRIGONOMETRIC EQUATIONS

105. The relation between the size of feed (radius b), the space between the rolls ($2a$), the radius of the rolls (r), and the angle of "nip" (N°) is

$$\cos\left(\frac{N}{2}\right) = \frac{r+a}{r+b}$$

a. Derive this equation from Fig. 35.

b. What is the relation for N in terms of r, a, b ? For r in terms of N, a, b ?

106. Figure 36 shows four circles that possess the indicated tangency properties. The radii of three circles are known: $\overline{OC} = 5$ in., $\overline{AB} = 3$ in., and $\overline{ED} = 2$ in. Determine the coordinates of the center P and the radius r of the circle BCD , this fourth circle being tangent to each of the three given circles.

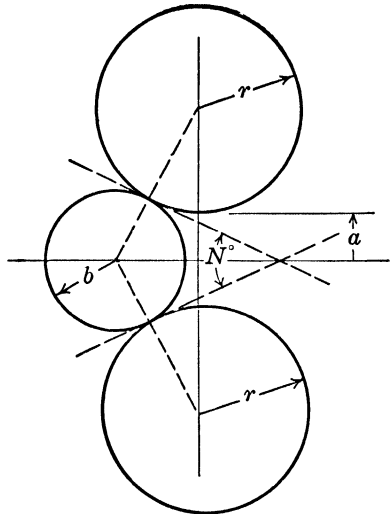

FIG. 35.

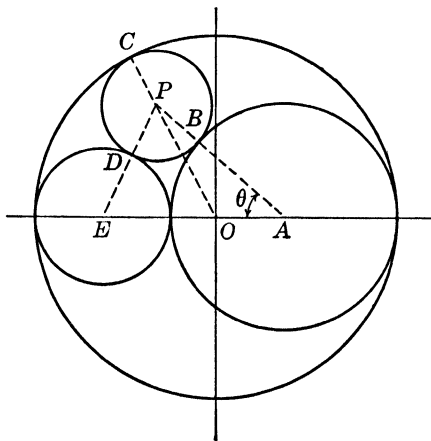

FIG. 36.

Suggestion: Angle θ is common to the two triangles OAP and OEP , and the dimensions of the sides for both of these triangles can be determined in terms of r .

107. When a block of weight W lb. is pulled up an inclined plane by a horizontally directed force (P lb.), the angle θ which the plane makes with the horizontal will make the efficiency a maximum if

$$\sin 2(\theta + \varphi) = \sin 2\theta.$$

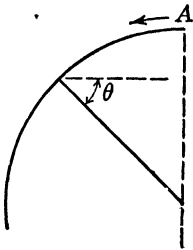

FIG. 37.

Mechanical efficiency is defined as the ratio of the useful work performed to the total energy expended (see Fig. 38).

$\tan \varphi$ is a measure of the friction between the block and the plane. Solve for the smallest acute angle θ if $\tan \varphi = 0.347$ (the proper value if the block is made of cast iron and the plane of steel).

108. A ski jumper starts down a hill from the point marked A (Fig. 37). The cross section of the hill is a circle of radius R . It can be shown, by methods of physics and mechanics, that the radius to the point at which he will leave the surface of the hill (neglecting friction, which is small) will make an angle θ with the horizontal where

$$\sin \theta = 2(1 - \sin \theta).$$

Determine this angle.

109. A body weighing W lb. rests on a rough plane inclined at an angle θ with the horizontal (Fig. 38). To determine the force P lb. that will just cause the body to begin to slide up the hill, one applies methods of mechanics to obtain the following equations:

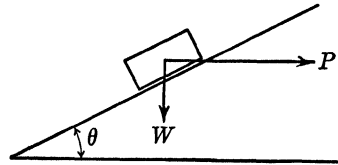

FIG. 38.

$$P \cos \theta - W \sin \theta = F, \quad N - W \cos \theta = P \sin \theta, \quad F = N \tan \varphi,$$

where $\tan \varphi$ is a measure of the friction between the body and the plane and F is the frictional force. Solve these three equations simultaneously for P and obtain $P = W \tan (\theta + \varphi)$.

110. The equation

$$\frac{\tan \alpha_2}{\tan \alpha_1} = \frac{u_1}{u_2}$$

is used in electrical engineering to determine the change in direction when magnetic lines pass from one medium to another. A special case yields

$$\tan \alpha_{\text{air}} = 1,000 \tan \alpha_{\text{iron}}.$$

Compute α_{air} in degrees correct to the nearest minute when $\alpha_{\text{iron}} = 0^\circ, 0.1^\circ, 1^\circ, 15^\circ, 30^\circ, 60^\circ$.

111. Snell's law from physics is

$$\frac{\sin \varphi_1}{\sin \varphi_2} = \frac{n_2}{n_1}$$

where n_1 and n_2 are the indices of refraction for two mediums through which light is passing, ϕ_1 and ϕ_2 are the corresponding angles. Tabulate the values for ϕ_{water} , correct to the nearest minute, corresponding to the following values for ϕ_{air}

$$1.33 \sin \phi_{\text{water}} = 1.000,292 \sin \phi_{\text{air}},$$

$$\phi_{\text{air}} = 0^\circ, 1^\circ, 10^\circ, 30^\circ, 45^\circ, 60^\circ, 90^\circ.$$

COMPLEX NUMBERS
DEMOIVRE'S THEOREM

112. At a certain instant the voltage in an electric circuit may be represented by a vector as shown in Fig.

40 and may be represented algebraically in each of the following forms: Trigonometric form:

$$\dot{E} = 100(\cos 45^\circ + j \sin 45^\circ), \quad j = \sqrt{-1},$$

Polar form:

$$\dot{E} = 100 \angle 45^\circ,$$

Exponential form:

$$\dot{E} = 100e^{j\pi/4}, \quad e \approx 2.718,$$

Rectangular form:

$$\dot{E} = 70.7 + j 70.7.$$

At the same instant the vector representing the current (\dot{I} amp.) is as shown in the figure.

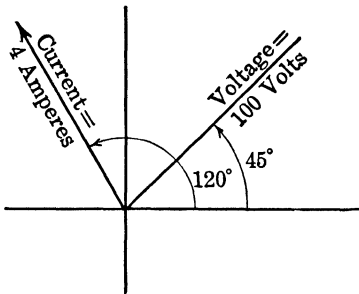

FIG. 40.

113. Suppose the voltage in an electric circuit is $e = E \sin \omega t$ volts and the current is $i = I \sin (\omega t + \theta)$ amp.

a. Show that these two quantities can be written as the imaginary parts (or vertical projections) of the following vectors:

$$\dot{E} = E(\cos \omega t + j \sin \omega t),$$

$$\dot{I} = I[\cos (\omega t + \theta) + j \sin (\omega t + \theta)].$$

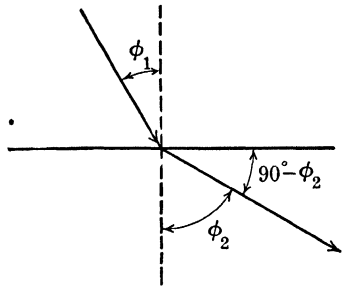

FIG. 39.

a. Represent the current \dot{I} in each of the above forms.

b. If the instantaneous power is the product of the imaginary parts of the voltage and current vectors, find its value.

c. If the average power is the product of the lengths of the voltage and current vectors multiplied by the cosine of the angle between these two vectors, find its value.

b. Represent these two vectors on a neat sketch. (Take ωt to be about 30° or $\pi/6$ radians and θ to be about $\pi/4$ radians.)

c. Give the values of these vector quantities in each of the other possible forms for complex quantities.

d. If the voltage and current are written in the forms

$$\dot{E} = E_1 + jE_2, \quad \dot{I} = I_1 + jI_2,$$

the "average power" in the electric circuit is given by

$$P = E_1I_1 + E_2I_2.$$

What does this become if one uses the trigonometric forms for the two quantities?

Remark: Electrical engineering analysis of a.c. circuits may be made by aid of sine waves, line values, or complex quantities. The sine-wave method utilizes the graph of the vertical or horizontal projections of these complex quantities (vectors) in terms of time, whereas the complex quantities show the circuit situation at a particular time, this time being represented as the angle for the voltage vector. Normally, the analysis uses the angle for the voltage vector as some integral multiple of 2π .

For a reasonable understanding at the junior level in electrical engineering, the student must have at his command an understanding of line values, sine waves, and complex-quantity manipulation.

114. An electric circuit has in series a resistance R ohms, an inductance L henrys, a capacitance C farads, and a voltage $e = E \sin \omega t$ volts. The "impedance" function for this circuit is

$$\dot{Z} = \sqrt{R^2 + \left(\omega L - \frac{1}{\omega C}\right)^2} \angle \tan^{-1} \frac{\left(\omega L - \frac{1}{\omega C}\right)}{R}.$$

a. Compute \dot{Z} and write your result in three other forms if

(1) $R = 10$ ohms, $L = 0$, $1/C = 0$, $\omega = 120\pi$ radians per second.

(2) $R = 30$ ohms, $L = 0.1$ henry, $1/C = 0$, $\omega = 120\pi$ radians per second.

(3) $R = 0$, $L = 0.0425$ henry, $1/C = 0$, $\omega = 120\pi$ radians per second, $\omega L = 16.0$. (Take 90° for the angle.)

(4) $R = 0$, $L = 0$, $C = 0.000,001,06$ farad, $\omega = 120\pi$ radians per second, $1/\omega C = 2,500$. (Take $\theta = -90^\circ$.)

b. If $\dot{E} = \dot{I} \cdot \dot{Z}$ and $\dot{E} = 100 + j0$, determine \dot{I} for each of the problems in (a).

115. If $V_a = 10 \angle 30^\circ$, $V_b = 30 \angle -60^\circ$, and $V_c = 15 \angle 145^\circ$, and if

$$\begin{aligned} V_{a1} &= \left(\frac{1}{3}\right)(V_a + aV_b + a^2V_c), \\ V_{b1} &= a^2V_{a1}, \quad V_{c1} = aV_{a1}, \end{aligned}$$

where $a = 1 \angle 120^\circ$, determine the values of V_{a1} , V_{b1} , V_{c1} .

116. If
$$V_{a1} + V_{a2} + V_{a0} = V_a,$$

$$a^2 V_{a1} + a V_{a2} + V_{a0} = V_b,$$
and
$$a V_{a1} + a^2 V_{a2} + V_{a0} = V_c,$$

where $a = 1 / \sqrt{120^\circ}$, solve for V_{a0} , V_{a2} , and V_{a1} each in terms of V_a , V_b , and V_c . Notice that $1 + a + a^2 = 0$.

117. Solve simultaneously the following three equations:

$$\begin{aligned} (19.4 / \sqrt{68^\circ}) I_1 - (9.70 / \sqrt{68^\circ}) I_2 &= 0, \\ -(9.70 / \sqrt{68^\circ}) I_1 + (19.4 / \sqrt{68^\circ}) I_2 - (3.04 / \sqrt{80.5^\circ}) I_3 &= 0, \\ -(3.04 / \sqrt{80.5^\circ}) I_2 + (8.08 / \sqrt{60^\circ}) I_3 &= 4,000 / \sqrt{-60^\circ}, \end{aligned}$$

which arise from an analysis of a three-mesh electric network. The results for I_1 , I_2 , I_3 are the currents flowing in the three branches.

118. The following mathematical manipulations are to be found in textbooks on a.c. circuits:

a. Perform the following indicated operations:

- (1) $(5 + j7) + (3 - j2) - (4 - j3)$.
- (2) $(5.00 + j8.66)(7.07 - j7.07)$.
- (3) $(3 - j4)(10 / \sqrt{90^\circ})(\cos 30^\circ + j \sin 30^\circ)(4\epsilon^{j\pi/2})$.
- (4) $(60 + j80)^{1/2}$ (give that root which has the smaller positive angle).
- (5) $\log_\epsilon (10 / \sqrt{60^\circ})$ (give the angle in radian measure).
- (6) The value of $\epsilon^{j\omega t}$ if $t = 0.002$ sec. and $\omega = 377$ radians per second.
- (7) $(4 / \sqrt{60^\circ})^3 / (2 / \sqrt{-30^\circ})^2$.

b. Find the rectangular, trigonometric, polar, and exponential expressions for a vector whose magnitude is 10 units and whose position is

- (1) 60° ahead of the reference (positive horizontal) axis.
- (2) 120° behind the reference axis.
- (3) 90° ahead of the reference axis.
- (4) On the reference axis.
- (5) 180° ahead of the reference axis.

c. Determine the values of R and θ if

$$(120 + j0) + 4R / \sqrt{-60^\circ} = 225 / \sqrt{-\theta^\circ}.$$

d. Plot $A\epsilon^{j\omega t}$ and $A\epsilon^{-j\omega t}$ in vector form if $\omega = 100\pi$ radians per second when

- (1) $t = 0.0025$ sec.
- (2) $t = 0.005$ sec.
- (3) $t = 0.00666$ sec.

e. Plot the vertical projection of $A\epsilon^{j\omega t}$ as a function of ωt for one complete cycle.

f. Plot $(A\epsilon^{j\omega t} + A\epsilon^{-j\omega t})/2$ as a function of ωt for one complete cycle.

119. Determine the "attenuation" α and the "phase shift" β for a certain type of electric filter if

$$(a) \quad \alpha + j\beta = 2 \log_e [\sqrt{(0.03155 / \underline{180^\circ})} + \sqrt{1 + (0.03155 / \underline{180^\circ})}].$$

Note: Use the smallest positive angles for the square roots.

$$(b) \quad \alpha + j\beta = 2 \log_e (A + B),$$

$$\text{where} \quad A = \sqrt{\frac{Z_1}{4Z_2}}, \quad B = \sqrt{\frac{Z_1}{4Z_2} + 1},$$

$$Z_1 = 29.6 / \underline{86.1^\circ}, \quad \text{and} \quad Z_2 = 10.61 / \underline{-90^\circ}.$$

Remarks: The preceding problems are all stated in terms of electric networks. However, much the same sort of problem could be stated for problems in mechanical vibrations.

PART III
ANALYTIC GEOMETRY
ELEMENTARY FORMULAS

120. Figure 41 shows a bridge truss. List the coordinates of $A, B,$ etc. Then find the slopes and inclinations of the members DE and EF .

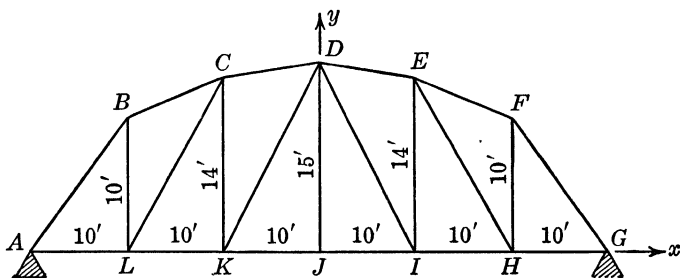

FIG. 41.

121. A weight of 3 lb. is placed at $A(1,2)$ and one of 5 lb. at $B(7,4)$. Determine the coordinates of the centroid of the system (that point which could be used as the fulcrum for a lever with ends at A and B) by finding the coordinates of a point P on AB such that $AP/PB = \frac{5}{3}$.

122. The modulus of elasticity, much used in strength of materials, is defined by $E = s/\epsilon$, where s is the unit stress (load per unit area) and ϵ is the unit strain (stretch per original unit length). A rod of steel stretches $\epsilon = 0.0005$ in. per in. when subjected to a stress of $s = 15,000$ lb. per sq. in. Determine E . Also determine the slope of the straight line joining the origin to the point with coordinates $(0.0005, 15,000)$.

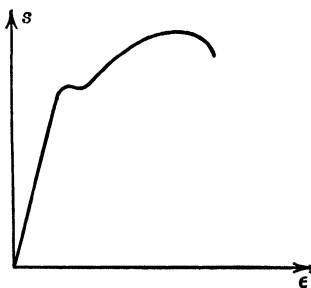

FIG. 42.

Remark: The stress-strain graph for steel is shown in Fig. 42. The modulus of elasticity, by definition, is the slope of the straight part of the graph. Hooke's law, which will be studied in physics, states that stress is proportional to strain, another definition for E .

123. The graph of centigrade temperature as a function of Fahrenheit temperature is a straight line. The student knows that 0°C . corresponds to 32°F . and 100°C . to 212°F . Sketch the graph relating centigrade (vertical) to Fahrenheit and determine the slope of the resulting straight line. State the meaning of the slope value in good English as it relates to the temperatures.

Note on Locus Derivations: There are no illustrative engineering applications of this topic in these problems. However, the following observations are important. The solution of a locus derivation problem involves the following steps:

First Step: Sketch a figure and label the given data.

Second Step: Select a *general* point on the locus, preferably one that seems graphically to satisfy the statement of the problem.

Third Step: Make a geometric statement that must hold for this general point on the basis of the statement of the problem.

Fourth Step: Translate this geometric statement to algebraic form with the aid of the coordinates of the general point.

Fifth Step: Simplify.

Sixth Step: Check.

Compare these steps with the four steps that constitute the *engineering method* for the solution of problems:

First Step: Sketch figures, such as free-body diagrams; label all relevant points, lines, etc.

Second Step: Determine what fundamental engineering principle applies (Newton's laws of motion, Ohm's law, basic theorems from plane geometry, etc.); apply and obtain a mathematical problem.

Third Step: Solve the mathematical problem.

Fourth Step: Discuss the engineering implications of the mathematical results, the limitations that were originally imposed, and their consequences.

Sometimes it is necessary to make more stringent assumptions at the second step. This may lead to a more difficult mathematical problem to solve in the third step. Such a situation arises when the results obtained in the fourth step are insufficiently accurate.

A committee of the Society for the Promotion of Engineering Education, in a report on the Aims and Scope of Engineering Curricula (*The Journal of Engineering Education*, March, 1940, p. 563), states that an engineering education should be directed, among other things, to a thorough understanding of this engineering method and elementary competence in its application.

Perhaps the student will see, by a comparison of the locus derivation process and the steps in the engineering method, that he is beginning in his freshman year to develop this required understanding and competence.

STRAIGHT LINES

124. Figure 43 shows a straight-line speed-time diagram. The times required for the three different motions are denoted by t_1 , t_2 , t_3 and the total time by T . The corresponding numerical values of the accelera-

tions shown in the accompanying legend are a_1, a_2, a_3 , and these are the numerical values of the slopes of the three straight lines.

a. Determine the coordinates of the points P, Q , and R .

b. Determine the total area enclosed by the polygon $OPQRO$, where O is the origin.

c. Since $T = t_1 + t_2 + t_3$ and $a_1t_1 - a_2t_2 - a_3t_3 = 0$ (why?), eliminate t_2 and t_3 between these two equations and the equation for A (the area) and simplify.

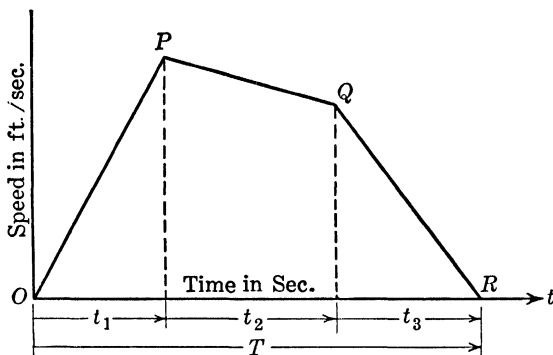

FIG. 43.—Slope $OP = a_1$, slope $PQ = -a_2$, slope $QR = -a_3$.

125. The natural length of a spring is 8 in. and a force F of 40 lb. is required for each inch it is increased in length. Show that the equation $F = 40(L - 8)$ lb. states these facts. Sketch the graph of the equation. Then determine the area between this straight line, the L axis, and $L = 9$ in. to $L = 12$ in., and give the proper units for the result.

126. A train (weight 200 tons without locomotive) starts to move with a constant acceleration. If the resistance to motion due to friction and air resistance is always 0.005 times the weight of the train, the pull in the drawbar between the locomotive and train is given by

$$F = F_1 + Ma \text{ lb.}$$

where $F_1 = (0.005)(200)(2,000) = 2,000$ lb. = resistance due to friction and air resistance, $M = (200)(2,000)/32.2 = 12,400$ slugs = "mass" of train, and a is the acceleration.

Note: Slug = $\frac{\text{lb.}}{\text{ft. per sec. per sec.}}$

Sketch for acceleration a from 0 to 10 ft. per sec. per sec. What is the force in the drawbar when the acceleration is zero and what geometrical significance does this value have?

127. Suppose i_b and e_b are the variables in the fourth equation in Prob. 64. What geometrical significance can you assign to the constants E_b, I_b , and R_L ?

128. The horizontal beam shown in Fig. 44 weighs 100 lb. per ft. of length and supports a pile of sand distributed as shown.

a. Obtain an equation for the weight of the beam itself for the first x ft. from the left support.

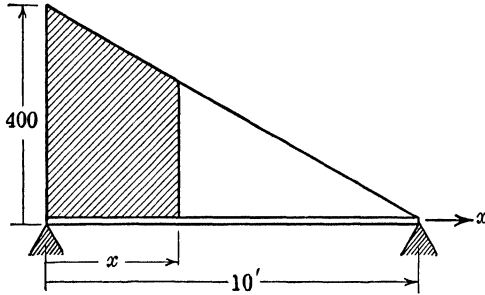

FIG. 44.

b. What is the equation of the straight line that forms the top of the sand (the ordinate is 400 lb. per ft. when $x = 0$ and is zero when $x = 10$ ft.)?

c. What is the area of the trapezoid, shown in the figure, whose base is x ft., and hence what is the weight of the sand above the first x ft. of the beam?

d. What is the equation for the total weight of beam and sand for the first x ft.?

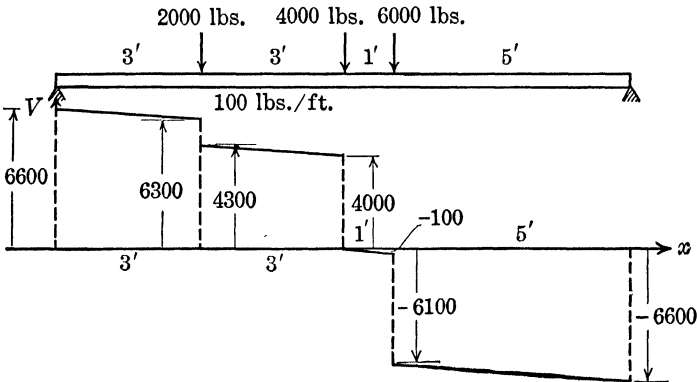

FIG. 45.

129. A beam is 12 ft. long as shown in Fig. 45. It supports three concentrated loads as shown. In strength of materials one learns what the term "shear" means.

a. In this problem you are to write the equations for the four shear lines (straight lines shown in the lower part of Fig. 45).

b. Also determine the total area bounded by these shear lines and the x axis (the area is positive if above the x axis and negative if below).

c. Determine the area between the first shear line and the x axis from $x = 0$ to $x = X$, where X is between 0 and 3; between 3 and 6; between 6 and 7; between 7 and 12.

130. Let R denote the electrical resistance in ohms of a copper wire 1 mm. in diameter and 1 meter long at a temperature of $T^\circ\text{C}$. If $R = 0.0203$ ohm when $T = 0^\circ$ and $R = 0.0286$ ohm when $T = 100^\circ\text{C}$., and if the relationship between R and T is linear, obtain the equation for R in terms of T and state your resulting equation in good English.

131. Sketch a number of graphs for $E = IR$ (Ohm's law in electrical engineering) using I as the independent variable and E as the dependent variable. Show graphs for $R = 0, 1, 2, 3,$ and 4 ohms. Notice that this equation has physical meaning only for positive values of E and I .

132. The actual over-all fuel consumption of alcohol-gasoline compared to unit volume of ordinary gasoline as found by road tests gives practically a straight line when plotted on the basis of calorific values of alcohol and gasoline. If R is consumption, and A is added alcohol: $R = 1.00 + 0.0060A$. Sketch and give the physical meanings for the slope and R intercept.

133. Dühring's rule gives an empirical relationship between the absolute boiling points of two substances at two different pressures. If T_A and T_B are the boiling points of two materials (A and B) at one pressure and $T_{A'}$ and $T_{B'}$ at a second pressure, then

$$T_A - T_{A'} = k(T_B - T_{B'}),$$

where k is a constant depending on the two materials. Discuss the graphical significance of this rule.

134. The pressure on a certain piston is related to the volume between the piston and cylinder head by the equation

$$p = 900V + 3,000 \text{ lb. per sq. ft.}$$

The work done in compressing the volume from 1 to 0.5 cu. ft. is equal to the area between the given curve, the V axis, from $V = 0.5$ to $V = 1$. Determine this area.

135. The specific heat of mercury c at a temperature of $T^\circ\text{C}$. is given by $c = 0.03346 - 0.000,009,2T$ calories per degree centigrade (at constant pressure). Sketch and determine the area between the straight line, the horizontal T axis, and $T = 0^\circ$ to $T = 50^\circ$. This area is equivalent to the heat required to raise the temperature of 1 gram of mercury from 0 to 50°C .

136. A cylinder is 12 ft. long and 10 in. in diameter and is lying on its curved side. One end is kept at a temperature of 10°C ., and the other

end at 100°C . If the curved part is perfectly heat-insulated and if the temperature at any point inside the cylinder is a linear function of its distance from one end, determine the equation for temperature in terms of the distance from the 10° end.

137. For an ideal gas the volume is a linear function of the temperature for a given constant gas pressure. If the equation is $v = v_0(1 + \alpha T)$, where v_0 is the volume at 0° abs. and $\alpha = \frac{1}{273}$, sketch the graph for v/v_0 in terms of T .

138. Figure 46 shows the graph for a water cycle. H is the heat quantity in calories per unit mass and T is temperature in degrees centigrade.

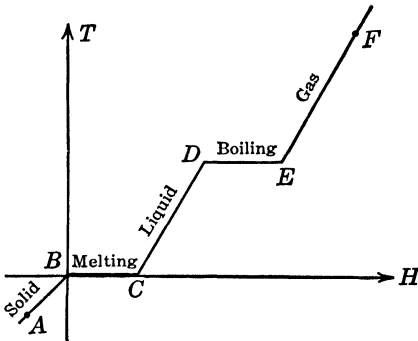

FIG. 46.

Point	H	T
A	- 20	- 20
B	0	0
C	+ 70	0
D	170	+100
E	529	100
F	625	300

a. Determine the equation of each of the straight-line segments.

b. Determine the area between the "liquid" line, the T axis, from $T = 0$ to $T = 100$.

139. The vertical load (s lb. per sq. ft.) at a distance of x ft. from the left edge of the base of the dam shown in Fig. 47 (the load is caused by the weight of the concrete and by water pressure) is given by

$$s = 1,650 + 70.9(x - 10).$$

Identify and sketch.

Remark: It might happen, though it does not occur in this problem, that s would be negative for certain values of x within the base of the dam. This would mean, physically, that the water was tending to overturn the dam and that in this interval the dam was tending to pull its earth support upward.

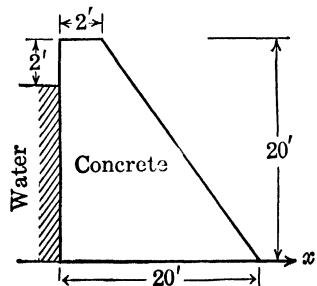

FIG. 47.

Determine the total load on the bottom of the dam by multiplying the area under the straight line from $x = 0$ to $x = 20$ by the length of the dam, which is 40 ft.

CURVE SKETCHING

140. An insulation wall is made up of a thickness of one material with a thermal conductivity k_1 and an equal thickness of a second material of thermal conductivity k_2 . The thermal conductivity of the total thickness k is then given by

$$\frac{1}{k} = \frac{1}{k_1} + \frac{1}{k_2}.$$

a. Sketch the graph using k/k_2 for the dependent variable and k/k_1 for the independent variable.

b. Sketch the graph using k_2/k for the dependent variable and k_1/k for the independent variable.

The conductivity k of a material is the amount of heat in British thermal units that will flow in 1 hr. through a layer of the material 1 sq. ft. in area when the temperature difference between the surfaces of the layer is 1°F . per in. of thickness.

141. If x is the number of cubic meters of oxygen used to burn completely a given amount of carbon and if y is the number of cubic meters of hydrogen required for the reaction, then

$$x + 0.5y = 0.353,$$

$$\text{and} \quad \left(\frac{1}{x}\right) - 1 = 10.662 \left(\frac{1}{y} - 1\right).$$

Plot the graphs and solve these two equations simultaneously.

142. If t is the thickness of a thick cast-iron cylinder, r is the interior radius, p is the allowable unit pressure, and s is the allowable unit stress, then

$$t = r \left(\frac{s}{2p + s} - 1 \right), \quad (\text{for the external pressure})$$

$$t = r \left(\frac{s + p}{s - p} - 1 \right), \quad (\text{for the internal pressure})$$

Sketch a graph of each equation using s/p as the independent variable and t/r as the dependent variable.

Remark: The variables in this problem, as suggested for the graph, are dimensionless variables. It is common engineering practice to discuss equations in terms of dimensionless-variable combinations.

143. A formula used in the design of beams that have been reinforced with steel is

$$p = \frac{1}{2(f_s/f_c)(1 + f_s/nf_c)},$$

where p is the percentage of reinforcement area with respect to the total cross-sectional area, f_s is the tensile unit stress for steel, f_c is the compressive unit stress for concrete, and n is the ratio of the modulus of elasticity for steel to that for concrete = $E_{\text{steel}}/E_{\text{concrete}} = 12$ approximately. Sketch a graph of p as a function of f_s/f_c .

144. A weight of W lb. hangs on a spring that stretches k ft. when a 1-lb. weight is attached. An oscillatory force $P \sin \omega t$ lb. is applied to the weight. At any time after the oscillatory force is applied, the deflection (y ft.) of the weight is given approximately by

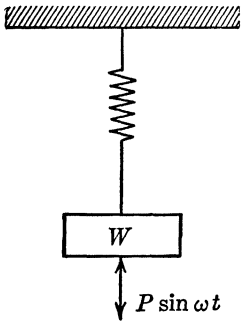

FIG. 48.

$$\frac{y}{a} = \frac{1}{1 - (\omega/\omega_n)^2} \sin \omega t,$$

where $a = P/k$ and $\omega_n^2 = kg/W$ ($g = 32.2$ ft. per sec. per sec.).

The maximum value (amplitude) of this motion is given by

$$\frac{y}{a} = \frac{1}{1 - (\omega/\omega_n)^2}.$$

a. Sketch a graph for this maximum value.

Use the dimensionless variable y/a as the dependent variable and ω/ω_n as the independent variable.

b. "Resonance" occurs for all positive values of ω/ω_n that would cause division by zero (which is never allowed). What are these values? To what in geometrical terms does resonance correspond?

Remark: ω_n is the natural frequency of the weight-spring system (without the oscillatory force). Resonance occurs when the frequency of the force is equal to the natural frequency of the system.

145. In Prob. 144 let the support oscillate according to the equation $Y = a_0 \sin \omega t$ ft. and omit the oscillatory force. Then the maximum value for the deflection (y ft.) of the weight is given by

$$\frac{y}{a_0} = \frac{(\omega/\omega_n)^2}{1 - (\omega/\omega_n)^2}.$$

Notice that a_0 is the amplitude of motion of the top of the spring and y is the relative motion between the weight and the top of the spring.

Sketch with the same variables as before and give the "resonance" values.

146. A simply supported beam (Fig. 49) is 12 ft. long and supports a concentrated load of P lb. at a distance of 8 ft. from the left end. The equation of the curve that the beam would assume is given as follows:

For x from 0 to 8:

$$\frac{y}{k} = \frac{x^3}{18} - \frac{64x}{9},$$

and for x from 8 to 12:

$$\frac{y}{k} = \frac{x^3}{18} - \frac{64x}{9} - \frac{(x-8)^3}{6}.$$

k is a large positive constant.

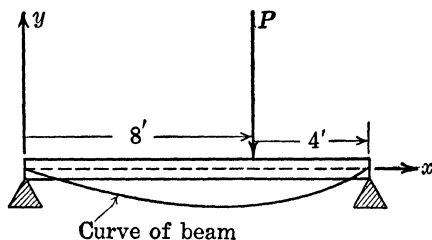

FIG. 49.

Sketch the graph for y/k in terms of x for the entire beam span. Use the method of addition of ordinates to sketch the right-hand portion.

147. The formula for the Brinell number, used in a hardness test for metals, is

$$B = \left(\frac{600}{\pi d^2} \right) (10 + \sqrt{100 - d^2}),$$

where d is the diameter or width (in millimeters) of the impression which a ball makes on the test specimen when dropped through a specified distance.

Plot a graph of B as a function of d with special emphasis on the interval from $d = 1$ to $d = 10$ mm. Verify the following data:

d	2.40	3.00	4.00	5.00
B	653	415	229	143

148. An approximate equation for the relation between steam decomposition and producer gas is

$$Y = \frac{0.99\varphi}{1 - \varphi} + 0.267(k - 1)\varphi^{1.319},$$

where φ is the ratio of the amount of water vapor to the amount of injected steam, k is the ratio of the amounts of nitrogen to liberated hydrogen, and Y is a function of these two quantities.

Sketch a series of curves by the method of addition of ordinates for Y in terms of φ for $k = 2, 4, 6, 8,$ and 10 . Let φ vary from 0 to 1.

149. Sketch a graph of

$$\frac{L}{r} = 0.14 - 0.08 \left(1 - \frac{z}{r}\right)^2 - 0.06 \left(1 - \frac{z}{r}\right)^4$$

for z/r from 0 to 1. This equation occurs in fluid mechanics.

150. Sketch $K = \frac{1.312(10^{14})}{(T + 0.382t)^4}$ for $t = 212^\circ$. K is the heat-transfer coefficient, t is the preheat temperature, and T is the retort temperature. This problem occurs in chemical engineering.

Change the axes on your sketch so that the result will be a graph for $t = 735^\circ$ (instead of for 212° as first used).

151. In a certain engine, the relationship between the pressure and the volume of gas, *i.e.*, in the space between the piston and cylinder head, is given by the equation

$$p = 144 \left(v^2 + \frac{8}{v}\right) \text{ lb. per sq. ft.,}$$

where v is volume in cubic feet. Sketch a graph of p as a function of v and estimate the value of the smallest positive pressure that can occur.

152. An empirical equation for train resistance R in lb. per ton of train weight for different speeds S in miles per hour is

$$R = 3.5 + 0.0055S^2 + \frac{16}{(S + 1)^2}.$$

Sketch a graph for S from 0 to 60 miles per hour. What would be a good empirical equation for speeds from 40 to 60 miles per hour?

GRAPHS OF THE CURVES: $y = ax^n$

153. Under certain conditions the plate current in a two-element vacuum tube is given by

$$I = K \cdot E^{3/2} \text{ amp.}$$

where E is the plate voltage, I is the plate current, and K is a positive constant that depends on the geometry of the tube.

a. What is the general shape of this curve of I as a function of E , irrespective of the value of K ?

b. Sketch for $K = 1$, for $K = 2$, and for $K = 3$.

154. The length of life L of a gas-filled Mazda lamp operated on voltage V volts is related to the life L_0 operated at the rated voltage V_0 by the equation

$$\frac{L}{L_0} = \left(\frac{V}{V_0}\right)^{-13.1}.$$

Sketch L/L_0 as a function of V/V_0 . Also sketch the following equations which are for lumen output Q , power output P , and lumens per watt K :

$$\frac{Q}{Q_0} = \left(\frac{V}{V_0}\right)^{3.38}, \quad \frac{P}{P_0} = \left(\frac{V}{V_0}\right)^{1.54}, \quad \frac{K}{K_0} = \left(\frac{V}{V_0}\right)^{1.84}.$$

155. A study of the formation of producer gas as made in chemical engineering leads to the equation

$$(b - a)v = x - x^{b/a},$$

where x is the proportion of residual water and v is the corresponding amount of carbon dioxide (CO_2). The constants b and a are numerical values that depend on the process.

If $a = 3.17$ and $b = 4.18$, sketch a graph for v in terms of x as x changes from 0 to 1. Then estimate from your graph the value of x that makes v a maximum.

156. The quantity of water (q cu. ft. per sec.) that flows over a particular type of spillway is given by

$$q = 3.08BH^{3/2},$$

where B is the width of the spillway in feet and H is the vertical distance from the top of the water in the spillway to the water level some distance before the water reaches the spillway passage.

Sketch a graph for q/B as a function of H .

157. A gas in an engine at a certain instant has a volume of 1 cu. ft. and is at a pressure of 14,400 lb. per sq. ft. The gas expands according to the law $pv = C_1$ until $v = 2$ cu. ft. and $p = 7,200$ lb. per sq. ft. It then expands according to the law $pv^{1.4} = C_2$ until $v = 6$ cu. ft. and $p = 1,550$ lb. per sq. ft. It then contracts according to the law $pv = C_3$ until $v = 3$ cu. ft. and $p = 3,100$ lb. per sq. ft. It then contracts according to the law $pv^{1.4} = C_4$ until $v = 1$ cu. ft. and $p = 14,400$ lb. per sq. ft.

Plot this "Carnot" gas cycle carefully on graph paper. Use v as the independent variable.

158. The equation $pv^n = C$, where n and C are positive constants, gives the relation of pressure to volume of a gas. Sketch p as a function of v for $n = 0, 0.5, 1, 1.25, 1.40, 1.60$, and 2.

159. The following three equations give the volume, speed, and cross-sectional area in a certain nozzle, each in terms of the pressure p :

$$\begin{aligned} V &= 0.962 \left(\frac{200}{p}\right)^{1/1.4} \text{ cu. ft. per lb.,} \\ v &= 2,500 \left[1 - \left(\frac{p}{200}\right)^{0.4/1.4}\right]^{1/2} \text{ ft. per sec.,} \\ A &= \frac{5V}{v} \text{ sq. ft.} \end{aligned}$$

Sketch these three graphs on the same axes. Use a range for p from 0 to 200.

160. A canal lock has vertical sides and a rectangular horizontal cross section of area M . The water discharges through an outlet of area A . The time (t sec.) required for the water level to fall from h_2 to h_1 ft. is approximately

$$t = \frac{M}{2A} (h_2^{1/2} - h_1^{1/2}).$$

a. If $h_2 = h_1 + y$ ft., show that

$$y = \frac{4A^2 t^2}{M^2} + \frac{4At(h_1^{1/2})}{M}.$$

b. If $A = 4\pi$ sq. ft., $M = 30,000$ sq. ft., and $t = 20$ min. = 1,200 sec., show that $y = 101 + 20.1 \sqrt{h_1}$, approximately, and sketch a graph of y as a function of h_1 .

161. A loud-speaker horn is to have a fixed length and fixed radii at the throat and mouth. Its outline is to be such that the radius y

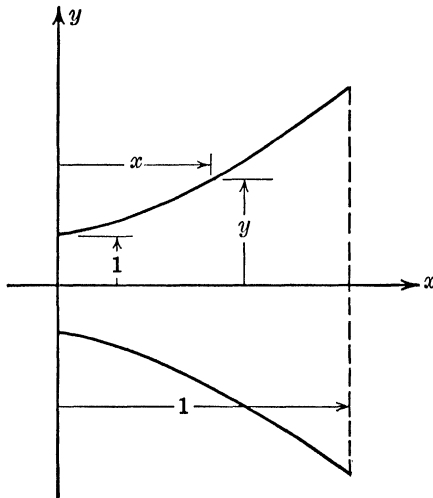

FIG. 50.

(see Fig. 50) is a power function of the distance along the axis, measured from some point to be determined. For convenience, take the origin at the center of the throat, the length as one unit, and the throat radius as one unit (of course to a different scale). Let the mouth radius be y_1 .

Obtain the equation for the top section of the horn by starting with the equation

$$y = k(x + a)^n.$$

Determine the values of the constants k and a so that the curve will go through $(0,1)$ and $(1,y_1)$ and show that the result is

$$y = [x(y_1^{1/n} - 1) + 1]^n.$$

If $y_1 = 10$ (vertical units), compute y when $x = 0.5$ for $n = 2, 10,$ and 100 .

Sketch the horn outlines on the same graph assuming that $y_1 = 10$ for the particular values of n : 1, 2, 3, and 5.

CIRCLES

162. Figure 51 is known as "Mohr's circle diagram" for stresses and is used in the course in strength of materials. Obtain the equation of

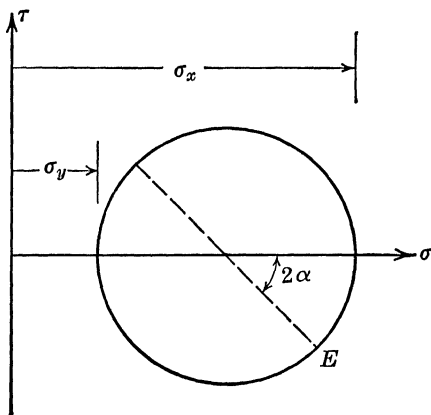

FIG. 51.

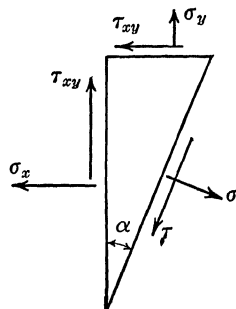

FIG. 52.

the circle in variables (σ, τ) and the coordinates of the point E , all in terms of the constants σ_x , σ_y , and α . The coordinates of point E are the values of the stresses σ and τ on the small triangular block shown in Fig. 52.

Remark: If one studies the stresses in a small triangular section of a beam (as shown in Fig. 52), the stresses on a plane making an angle α as shown $\left(\tan 2\alpha = \frac{2\tau_{xy}}{\sigma_x - \sigma_y} \right)$ are given by $\sigma = \frac{\sigma_x + \sigma_y}{2} + \frac{\sigma_x - \sigma_y}{2} \cos 2\alpha$,

$$\tau = \left(\frac{1}{2}\right)(\sin 2\alpha)(\sigma_y - \sigma_x).$$

163. Determine the equation relating I_1 and I_2 (in terms of E/R) in the triangle shown in Fig. 53. Discuss your result.

Remark: Texts on alternating currents use circle diagrams to study the real and imaginary parts of the vector current. The present example is for a series circuit consisting of a resistance and inductance.

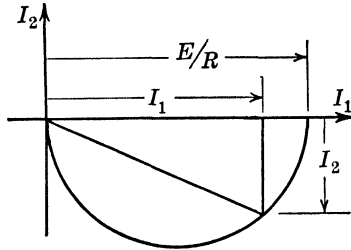

FIG. 53.

164. *a.* Show that the equations

$$\varphi = \frac{q}{4\pi} \ln [(x + a)^2 + y^2] - \frac{q}{4\pi} \ln [(x - a)^2 + y^2],$$

$$\eta = \frac{q}{2\pi} \tan^{-1} \left(\frac{y}{x + a} \right) - \frac{q}{2\pi} \tan^{-1} \left(\frac{y}{x - a} \right),$$

can be rewritten in the following forms:

$$(x + a)^2 + y^2 = e^{4\pi\varphi/q} [(x - a)^2 + y^2],$$

$$\tan \frac{2\pi\eta}{q} = -\frac{2ay}{x^2 + y^2 - a^2},$$

and that these two equations can be written in turn in the forms [where $b = e^{4\pi\varphi/q}$ and $c = \cot (2\pi\eta/q)$]

$$\begin{aligned} x^2(1 - b) + 2ax(1 + b) + y^2(1 - b) &= a^2(b - 1), \\ x^2 + y^2 + 2ayc &= a^2. \end{aligned}$$

b. Identify these two curves, assuming that a , b , and c are constants.

c. Let $a = 1$ unit (=1 in.). Sketch the first curve for $b = 3, 1.5, 1.2, 1.1, 1, 0.9, 0.8,$ and 0.6 . Sketch the second curve for $c = 2, 1, 0.5, 0,$ $-0.5,$ and -1 .

Remark: Your resulting graph has the following properties: Suppose that at the point $(-a, 0)$ in your sheet of paper you allow water to flow out in all directions (the sheet of paper to be horizontal and of unlimited length and width). Suppose that there is a small drain pipe placed at $(a, 0)$. Then the second set of curves you drew were the "path lines" for the flow. The first set of curves has a physical significance that will not be described here.

This same type of problem occurs in the study of the flow of heat, electricity, and moisture, in the study of a drying process, etc.

165. Use a sheet of graph paper and draw to a large scale the circle with center at $(0.2, 0.5)$ and radius 1.3. Let the coordinates of any point on this circle be designated by (x, y) and write $z = x + iy$, as you may have done either in college algebra or in trigonometry in connection with complex numbers. Read from your graph the approximate coordinates of a number of points on the circle and write each pair

in the z form. Compute $w = z + (1/z)$ for each such value of z . Plot the values of $w = u + iv$ on a new sheet of rectangular graph paper with v as the vertical scale and u as the horizontal. If you are careful and use enough points on the original circle, your resulting graph on the u, v axes will be a possible airfoil.

PARABOLAS

166. A beam AB of length L ft. and weight W lb. is hinged at B and held in a horizontal position at A (see Fig. 54). When released at A the beam begins to rotate about B . At the instant it is vertical, the end B is released and the entire beam falls. The equation of the path traced by the center of the beam after B is released, referred to the indicated axes, is $4y^2 = 6Lx - 3L^2$. Identify and sketch using y/L as a function of x/L (dimensionless variables).

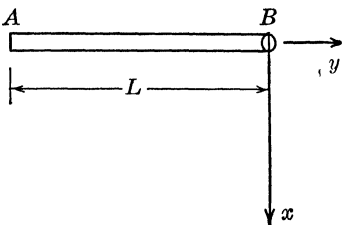

FIG. 54.

167. Figure 55 shows a beam which is built in at both ends. The “bending moment” (to be defined when you take strength of materials) for this beam is given by $M = wLx/2 - wL^2/12 - wx^2/2$, where x ft. is measured from the left-hand wall.

Identify and sketch a graph of $Y = M/wL^2$ as a function of $X = x/L$ (dimensionless variables). Then determine the coordinates of the highest point and the X and Y intercepts. Give the equivalent values for M and x for each of these points.

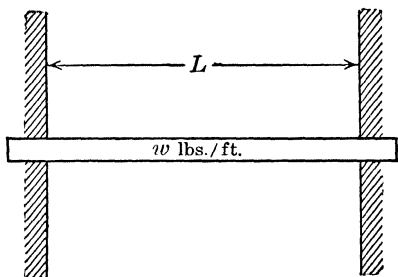

FIG. 55.

Remark: All these points have physical significance. The larger of the numerical values of the Y intercept and the Y value of the vertex determines the point in the beam where the stress is largest. The X intercepts determine those points in the beam where the tension or compression (pull or push) is zero.

168. A simply supported beam (Fig. 56) is 12 ft. long, is made of yellow pine, and is rectangular in cross section, being 6 in. wide and 10 in. deep. The equation of the “curve of the beam” is given as follows:

For x from 0 to 3 ft.:

$$y = 0.000,349x^3 - 0.028,27x \text{ ft.},$$

For x from 3 to 9 ft.:

$$y = 0.003,142x^2 - 0.037,70x + 0.009,42,$$

For x from 9 to 12 ft.:

$$y = 0.000,349(12 - x)^3 - 0.028,27(12 - x).$$

a. Identify the curve of the middle portion of the beam and determine its lowest point.

b. Plot a graph of the "curve of the beam" for the span of the beam, *i.e.*, for x from 0 to 12 ft.

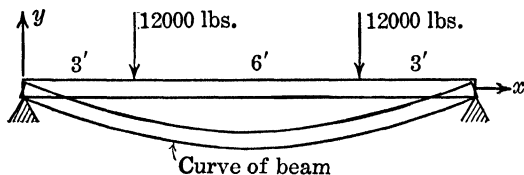

FIG. 56.

169. A weight is thrown directly downward from the top of a high building with an initial speed of 48 ft. per sec. Its distance below the top of the building (neglecting air resistance) t sec. after being thrown is $s = 16t^2 + 48t$ ft.

a. Identify and sketch the graph of this locus.

b. Determine the time when the weight hits the ground if the building is 640 ft. high.

170. A cable supporting a suspension bridge hangs in the form of a parabola. The tops of the supporting towers are 35 ft. above the floor of the bridge and the lowest point of the cable is 5 ft. above the bridge. The distance between the supporting towers is 60 ft. Determine the length of a suspending cable (a vertical cable from the bridge to the parabolic cable) 10 ft. from one of the supporting towers.

171. A bullet is fired upward at an angle θ with the horizontal and with an initial velocity of V ft. per sec. (see Fig. 57).

The equation of the path of the bullet referred to axes as shown (neglecting air resistance, etc.) is given by

$$x = Vt \cos \theta,$$

$$y = -\frac{gt^2}{2} + Vt \sin \theta,$$

where $g = 32.2$ ft. per sec. per sec., approximately.

a. Solve the first equation for t in terms of x , V , and θ and substitute for t in the second equation. Simplify and obtain

$$y = -\left(\frac{gx^2}{2V^2}\right) \sec^2 \theta + x \tan \theta.$$

b. Show that the equation of the directrix of this parabola is

$$y = \frac{V^2}{2g}.$$

Remark: This result is independent of the angle θ . Hence the directrix is the same irrespective of the angle of fire. This y value for the directrix is the distance the bullet would rise if fired vertically.

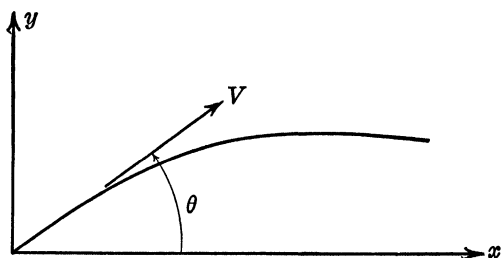

FIG. 57.

172. An empirical equation for the resistance of a locomotive and tender to motion on a straight level track is

$$L = 6.0 + 0.0035(S - 10)^2,$$

where L is resistance in pounds per ton of weight and S is speed in miles per hour.

a. Sketch L for values of S from 0 to 50 miles per hour.

b. What is the smallest resistance and at what speed does it occur?

173. Figure 58 shows a cable suspended from a trestle. If the curve of the cable is a parabola, determine the lengths of AC , CD , and BD , each in terms of L and p .

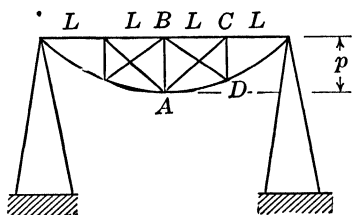

FIG. 58.

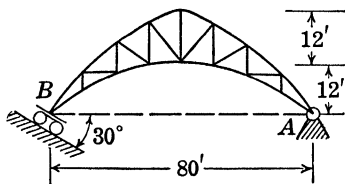

FIG. 59.

174. Figure 59 shows an arched truss 80 ft. long, hinged at A and on rollers at B . The rollers roll on a plate that makes an angle of 30° with the horizontal. The vertical stringers are 10 ft. apart.

Determine the sum of the lengths of the vertical and inclined stringers, correct to three significant figures, assuming that both the top and bottom of the arch are arcs of parabolas. One method of obtaining this

result is to plot the figure carefully to a large scale and measure the lengths of the separate stringers.

***175.** A gun at A fires a projectile which pierces a captive balloon at B and then hits the ground at C . The plane of the ground is horizontal. Let D be the projection of B on this plane. The distance $AD = 2,000$ ft., $DC = 1,000$ ft., the angle of elevation of the balloon from A is $\text{arc tan } \frac{3}{8}$. A first approximation for the curve which the projectile follows is a parabola.

a. Determine the equation of the path of the projectile, referred to axes through A .

b. What is the maximum height that the projectile reaches? That is, what is the ordinate to the vertex?

c. What are the values of the slope and inclination of the chord through A and the point on the parabola whose abscissa is $x = 1$ ft. and hence what is an estimate of the angle at which the projectile was fired?

176. At what speed must an open, vertical, cylindrical vessel, 4 ft. in diameter and 6 ft. deep and filled with water, be rotated about its axis so that the effect of rotation will be to uncover a circular area on the bottom of the vessel 2 ft. in diameter? The cross section of the inner surface of the rotating water will be an arc of a parabola. The equation of this parabola, referred to axes through its vertex (the y axis will be along the axis of the cylinder and the vertex will be below the bottom of the vessel) is $y = \omega^2 x^2 / 2g$, where ω radians per second is the angular speed of the vessel and g is approximately 32 ft. per sec. per sec.

177. If y is the concentration of acetic acid in ether and x is the concentration of acetic acid in benzene, it has been found that $y^2 = kx$ where k is an empirical constant. Sketch a schematic graph.

178. With reference to the $i_b - e_c$ equation described in Prob. 228, determine the coordinates of the vertex and sketch the curve.

ELLIPSES

179. In a course on strength of materials one makes use of the "ellipse of stress" whose equation is $(x^2/s_2^2) + (y^2/s_1^2) = 1$, where s_2 and s_1 are constants. Sketch the graph if $s_2 = 6,360$ lb. per sq. in. and $s_1 = 2,640$ lb. per sq. in.

180. Engineering mechanical drawing courses sometimes include a method of constructing a rough ellipse. A rhombus is constructed and lines are drawn from the "wide" angles to the mid-points of the opposite sides. The intersections of these lines by pairs on the line joining the "small" rhombus angles are the centers for two circular arcs. The vertexes at the wide angles are the centers for two other circular arcs and the four arcs make a crude ellipse.

a. Construct such an ellipse using vertexes at $(0, -b)$, $(-k, 0)$, $(0, b)$, and $(k, 0)$ and $b = 3$, $k = 6$.

b. Determine the value of a (the semimajor axis) for this special case.

c. What is the error in y in this special case when $x = 4$? The percentage of error?

d. Determine a formula for a in terms of b and k .

181. An airplane strut is 6 ft. long and is tapered uniformly from the middle toward both ends. Every section of the strut is an ellipse. The axes at the middle are $2a = 1$ in. and $2b = 0.75$ in. and at both ends $2a = 0.75$ in. and $2b = 0.5$ in. a and b are each linear functions of the distance x from the center.

a. Determine the relations for a and b in terms of x (inches).

b. Determine the cross-sectional area as a function of x in. and sketch its graph.

182. An arch has a cross section, as shown in Fig. 60, with the curve a semiellipse.

a. Determine the lengths of the ordinates to the arch measured from the ground at every 2 ft. distance from the point A .

b. If the arch is 10 ft. thick, determine the number of cubic yards of concrete necessary in its construction.

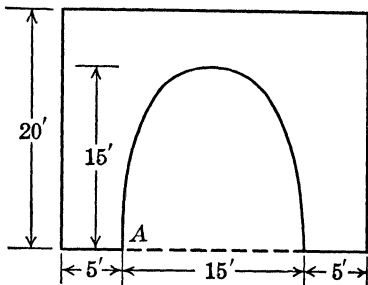

FIG. 60.

HYPERBOLAS

183. Sketch a graph of X as a function of the positive values of f if $X = 2\pi fL - 1/(2\pi fC)$ for the following sets of values for L and C . Determine algebraically and from your graph the value of f that makes X zero.

a. $L = 0.00025$ henry, $C = 10^{-10}$ farad (data for a radio circuit).

b. $L = 1$ henry, $C = 7(10^{-6})$ farad (data for a power circuit).

Remark: This equation gives the net "reactance" X in an a.c. circuit containing inductance L and capacitance C (as well as resistance R) in series with a sinusoidal voltage of frequency f .

184. Use is made in radio theory of the "gain" obtained by the use of a three-element vacuum tube. The formula for this gain is

$$\text{Gain} = \frac{\mu R_L}{R_p + R_L}$$

where R_p is the plate resistance and R_L is the load resistance.

a. Sketch a graph of gain/μ as a function of R_p/R_L and identify the curve.

b. Sketch a graph of gain/μ as a function of R_L/R_p and identify the curve.

185. An indicator card, which shows how the pressure varies with the volume in an engine cylinder, has the theoretical shape shown in

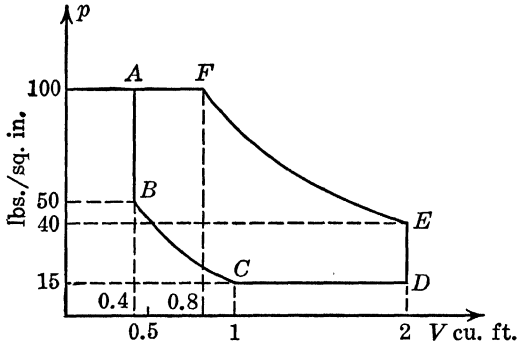

FIG. 61.

Fig. 61. Determine the equation of each part of the graph assuming that the curves BC and FE are arcs of hyperbolas ($pV = \text{constant}$).

a. Use p in pounds per square inch and V in cubic feet.

b. Use p in pounds per square foot and V in cubic feet.

186. The following equations give the "kinematic viscosity" (K.V.) = y in terms of S in "Saybolt seconds":

$$y = 0.002,168 - \frac{1.88}{S} \text{ for } S \text{ from } 0 \text{ to } 100,$$

$$y = 0.002,205 - \frac{1.35}{S} \text{ for } S \text{ larger than } 100.$$

Sketch $y = \text{K.V.}$, as a function of S for S from 0 to 200.

187. In the study of strength of materials one has the formula

$$S_t = \left(\frac{s_t}{2}\right) + \left(\frac{1}{2}\right)(s_t^2 + 4s_s^2)^{1/2},$$

which gives the maximum tensile unit stress S_t when a bar is subjected to combined tensile and twisting loading, as suggested by Fig. 62. In this formula s_t is the tensile unit stress due to the axial load (P lb.) and s_s is the shearing unit stress due to the twisting load.

a. Assuming that $s_s = 400$ lb. per sq. in., identify and sketch the graph of S_t as a function of s_t . Use the positive value of the square root.

b. Determine the relation approached between S_t and s_t as s_t increases without limit through positive values and give the geometrical significance of this result.

c. Determine the relation approached between S_t and s_t as s_t increases without limit numerically but through negative values. Give the geometrical significance.

d. In this same problem, the minimum tensile unit stress (or maximum compressive unit stress) is given by

$$S_c = \left(\frac{s_t}{2}\right) - \left(\frac{1}{2}\right)(s_t^2 + 4s_s^2)^{1/2},$$

and the maximum shearing unit stress is given by

$$S_s = \frac{1}{2}(s_t^2 + 4s_s^2)^{1/2}.$$

Sketch these two curves on the same graph with your first curve (for the same value assigned to s_s).

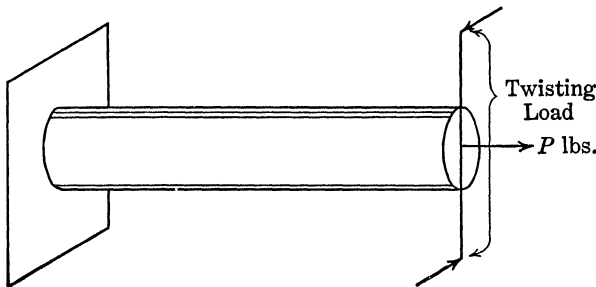

FIG. 62.

188. A listening post B is 4 miles east and 3 miles south of a listening post at A . The explosion of a gun is heard at B 10 sec. before it is heard at A , and the explosion sound comes from an easterly direction. Since sound travels at about 1,086 ft. per sec., the gun is about 10,860 ft. closer to B than to A .

a. By graphical methods construct the asymptotes for the hyperbola defined by the given data and sketch in the curve on which the gun must approximately lie.

b. Choose the x axis through the two listening posts and the y axis as the perpendicular bisector of the line segment AB and determine the equation of the hyperbola.

ROTATION OF AXES

189. The foundation bolts for a certain machine are to be placed at the points A, B, C, \dots, L , as indicated in Fig. 63. Determine the

distances from the two walls, marked as the x and y axes, to each bolt center.

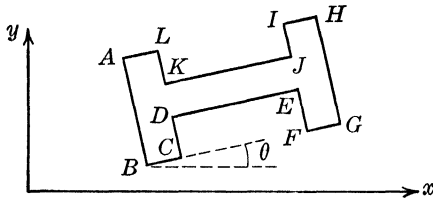

FIG. 63.

Data: $A_x = 3$ ft., $A_y = 5$ ft.,

$$AB = BII = 4 \text{ ft.},$$

$$AH = 7 \text{ ft.}, \quad \theta = 30^\circ,$$

$$BC = CD = KL = EF = EG = AL = 1 \text{ ft.}$$

190. Figure 64 represents an airplane climbing upward. Let L be the lift force, D the drag force, N the force perpendicular to the direction of climb, T the force in the direction of climb, and α the angle of climb. Show that

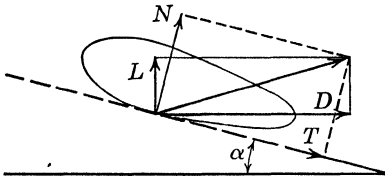

FIG. 64.

$$N = L \cos \alpha + D \sin \alpha,$$

$$T = -L \sin \alpha + D \cos \alpha,$$

and also determine a similar set of formulas for L and D in terms of N , T , and α .

GRAPHS OF SINE WAVES

191. Given the equation $y = Y_m \cos(\omega t + \alpha)$, t in seconds.

a. Sketch the graph if $Y_m = 3$, $\omega = 2$ radians per second, and $\alpha = \pi/6$ radians. Label the maximum value Y_m , the angular frequency ω , the period $p = 2\pi/\omega$, and the phase angle α (label it as the abscissa from $\omega t = -\alpha$ to $\omega t = 0$). Sketch a second graph using ωt as the independent variable and label the above quantities.

- b. Show that the equation may be written in the form

$$y = Y_m \sin\left(\omega t + \alpha + \frac{\pi}{2}\right).$$

c. If the axes are translated in your second sketch so that the equation is $y' = Y_m \cos(\omega t')$, what are the equations of translation?

192. If the total current in a conductor is the sum of the two components: $i_1 = I_1 \cos \omega t$ amp., $i_2 = I_2 \cos(\omega t - \theta)$, where I_1 and I_2 are both positive constants, show that the sum $i = i_1 + i_2$ can be

written as a cosine wave in the same form as that for i_2 , determine its amplitude, period, and phase with respect to i_1 , and sketch all three curves (schematically) on the same graph. Use ωt as the independent variable.

193. In a three-phase system, three outgoing currents in three different wires are, respectively

$$\begin{aligned}i_1 &= I \cos 2\pi ft \text{ amp.}, \\i_2 &= I \cos \left(2\pi ft - \frac{2\pi}{3} \right) \text{ amp.}, \\i_3 &= I \cos \left(2\pi ft - \frac{4\pi}{3} \right) \text{ amp.},\end{aligned}$$

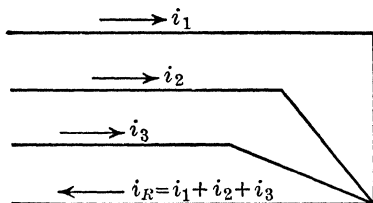

FIG. 65.

and all three have a common return wire which carries the current

$$i_R = i_1 + i_2 + i_3 \quad (f \text{ is frequency and } \omega = 2\pi f).$$

Evaluate i_R in the form of the given currents and sketch all four waves on the same graph. Use a common abscissa variable $2\pi ft$.

194. In a problem similar to the preceding, suppose that i_R is known to be zero and that $i_1 = I \cos 2\pi ft$, $i_2 = I \cos (2\pi ft - 5\pi/6)$. Use the equation $i_R = i_1 + i_2 + i_3 = 0$ to express i_3 as a sinusoidal function of time in the same form as the functions for i_1 and i_2 . Sketch all three curves on the same graph and give the amplitude, frequency, and phase angle for the graph of i_3 . Use $x = 2\pi ft$ as the independent variable.

195. The mechanism shown in Fig. 66 is a piston at the end of a connecting rod. The crank arm OA is 10 in. long and revolves at $\omega = 120$ revolutions per minute $= 4\pi$ radians per second.

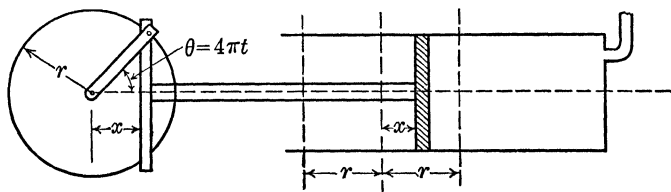

FIG. 66.

a. Show that the displacement of the piston from the position it would occupy when the crank arm is vertical is given by

$$x = 10 \cos 4\pi t \text{ in.} = \frac{5}{6} \cos 4\pi t \text{ ft.}$$

b. By methods of calculus it can be shown that the speed and acceleration of the piston at any time t sec. are given by

$$\begin{aligned}v &= \text{speed} = -(4\pi)\left(\frac{5}{6}\right) \sin 4\pi t \text{ ft. per sec.}, \\a &= \text{acceleration} = -(16\pi^2)\left(\frac{5}{6}\right) \cos 4\pi t \text{ ft. per sec. per sec.}\end{aligned}$$

Sketch on the same graph the graphs of x , v , and a , each as a function of time t sec.

c. The force that the crank arm transmits to the piston is always given by force = (mass)(acceleration). If the moving mechanism weighs 100 lb., it can be shown by methods of physics that the mass is $10\frac{1}{2}$ and hence that the force is

$$F = \left(\frac{100}{32}\right) \left(-40 \frac{\pi^2}{3}\right) \cos 4\pi t \text{ lb.}$$

Sketch a graph of F as a function of t .

196. A streetcar oscillates harmonically in a vertical direction on its springs. The amplitude of motion is 1 in., the frequency is 2 cycles per second, the loaded cab weighs 20,000 lb., and the truck and wheels weigh 2,000 lb. The force acting on the rails at any time t sec. can be shown by methods of mechanics and calculus to be approximately

$$\begin{aligned} F &= 22,000 + \left(\frac{1}{12}\right) (16\pi^2) \left(\frac{20,000}{32.2}\right) \sin 4\pi t \\ &= 22,000 + 8,170 \sin 4\pi t \text{ lb.} \end{aligned}$$

Sketch a graph of F as a function of the time. What is the maximum force acting on the rails? The minimum force?

197. The terminal voltage of an a.c. generator and the current supplied are, respectively,

$$\begin{aligned} e &= 100 \sin 120\pi t \text{ volts,} \\ i &= 5 \sin \left(120\pi t + \frac{\pi}{3}\right) \text{ amp.} \end{aligned}$$

Sketch e and i on the same graph as functions of the common abscissa $\theta = 120\pi t$, but with different meanings for their ordinates. Also sketch on the same graph the product $p = e \cdot i$, which is the instantaneous electrical power delivered by the alternator. You can simplify your work to obtain the last graph by first expressing

$$p = e \cdot i = 500(\sin 120\pi t) \sin \left(120\pi t + \frac{\pi}{3}\right) = 125 - 250 \cos \left(240\pi t + \frac{\pi}{3}\right).$$

198. The impressed voltage in an electric circuit is given by

$$e = 100 \sin (120\pi t) + 20 \sin \left(360\pi t - \frac{\pi}{4}\right) \text{ volts.}$$

Sketch e as a function of $\theta = 120\pi t$ radians; t is in seconds.

199. The equation of an amplitude-modulated voltage in radio is given by

$$e \text{ volts} = 100(1 + 0.7 \cos 4,000t - 0.3 \cos 8,000t) \sin 4,000,000t,$$

where t is in seconds.

a. Sketch the boundary curves for one cycle; *i.e.*, sketch

$$e = \pm 100(1 + 0.7 \cos 4,000t - 0.3 \cos 8,000t).$$

b. From your graph estimate the peak value of the given voltage.

EXPONENTIAL AND LOGARITHMIC GRAPHS

200. The current flowing in a series circuit (with inductance L henrys, resistance R ohms, and a voltage E volts) is given by

$$I = \left(\frac{E}{R}\right)(1 - e^{-Rt/L}) \text{ amp.}$$

and the power going into the magnetic field is given by

$$P = \left(\frac{E^2}{R}\right)(e^{-Rt/L} - e^{-2Rt/L}).$$

a. If $R = 10$ ohms, $L = 0.0001$ henry, and $E = 15$ volts, sketch graphs of P and I as functions of the time t .

b. Sketch graphs of RI/E and RP/E^2 as functions of Rt/L . These are dimensionless variables.

201. In the circuit of Prob. 200, the power going into the resistance is given by

$$P_R = I^2R$$

and the energy stored in the inductance is given by

$$P_L = \frac{LI^2}{2}.$$

Using the formula for I in Prob. 200 and these formulas, sketch graphs of $P_R R/E^2$ and $P_L R^2/LE^2$ as functions of Rt/L .

202. A problem in engineering required the simultaneous solution of the two equations:

$$\begin{aligned} 35 &= E_m(1 - e^{-\eta}), \\ 64 &= E_m(1 - e^{-4\eta}). \end{aligned}$$

What method would you devise for solving these two equations simultaneously, if the accuracy required is two significant figures? What is the common solution to that accuracy?

203. The following is taken from an article in *Chemical Engineering* on gasoline cracking. Sketch graphs of x and y as functions of the time t if

$$x = 100(1 - e^{-kt}) \quad \text{and} \quad y = 100e^{-kt}$$

where $k = 0.01076$.

204. The "magnetic flux" (in maxwells per centimeter of length) between two parallel wires of a transmission line is given by

$$\varphi = 0.4I \log_e \frac{D - r}{r},$$

where I is the current in amperes, D is the distance in centimeters between the centers of the two wires, and r is the radius of the wires in centimeters.

Sketch a graph of φ/I as a function of r/D . What happens graphically and what happens physically when $r/D = \frac{1}{2}$?

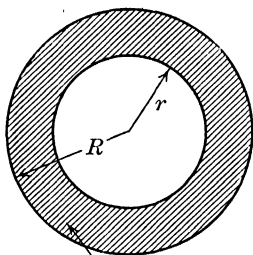

Insulation

FIG. 67.

205. In a cylindrical cable in which the inner conductor has a radius r and the outer conductor has a radius R (see Fig. 67) the maximum electric intensity in the insulation (there is some loss of current through the insulation) is given by

$$E_m = \frac{V}{r \log_e (R/r)}$$

and occurs at the surface of the inner conductor. (Electrical breakdown occurs when the voltage V between the conductors is large enough to make E_m greater than a particular value which depends on the kind of insulation.) If $y = E_m R/V$ and $x = r/R$, show that

$$y = -\frac{1}{x \log_e x}.$$

a. Sketch a graph of RE_m/V as a function of r/R for $0 < r/R < 1$.

b. Estimate from your graph the value of the ratio r/R that gives the smallest value for E_m , assuming that V and R are constants.

c. Sketch a graph of E_m as a function of V if $R = 2r = 0.6$ cm.

206. An equation for "belt friction" is

$$T_1 = T_2 e^{\mu\alpha},$$

where μ is the coefficient of friction, α is the angle of contact, and T_2 and T_1 are the "pulling" forces on the two ends of the belt (see Fig. 68).

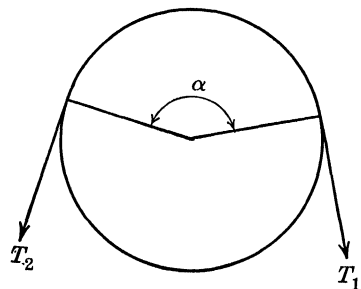

FIG. 68.

a. Sketch a graph of T_1/T_2 as a function of α , if $\mu = 0.4$. Show the graph for α from 0 to 4π .

b. Compute T_1 if $T_2 = 1,300$ lb., $\mu = 0.3$, and $\alpha = 3\pi/4$ radians.

207. A weight hangs at the end of a spring and vibrates so that its deflection, y ft., from a certain position is always given by

$$y = e^{-0.02t}(0.4 \sin 100t + 0.3 \cos 100t) \text{ ft.}$$

t is in seconds.

- a. Sketch a graph of y as a function of t from $t = 0$ to $t = 0.1$ sec.
- b. Show that the equation can be rewritten in the form

$$y = Ae^{-0.02t} \sin (100t + \theta),$$

and compute the values for A and θ .

- c. Determine the time t sec. after which y is always less than 0.005 ft. (Answer this question by solving for t in $0.5e^{-0.02t} = 0.005$.)

208. If a gas expands in a cylinder according to Boyle's law ($pV = \text{constant}$ for a constant temperature), the work the gas does is given by

$$W = (p_1V_1) \log_e \left(\frac{V_2}{V_1} \right),$$

where p_1 is the initial pressure, V_1 is the initial volume, and V_2 is the final volume.

- a. Sketch a graph of W as a function of V_2 if $p_1 = 600$ lb. per sq. ft., and $V_1 = 0.4$ cu. ft.
- b. Sketch a graph of W/p_1V_1 as a function of V_2/V_1 .
- c. Compute W if $p_1 = 600$ lb. per sq. ft., $V_1 = 0.4$ cu. ft., and $V_2 = 0.85$ cu. ft.

HYPERBOLIC FUNCTIONS

209. A cable of length L ft. is suspended between two points which are in the same horizontal plane and which are a ft. apart. Given that the length of the cable is $L = 2c \sinh (a/2c)$ and the sag is

$$f + c = c \cosh \left(\frac{a}{2c} \right).$$

If $L = 100$ ft. and $a = 80$ ft., these equations become

$$100 = 2c \sinh \left(\frac{40}{c} \right), \quad f + c = c \cosh \left(\frac{40}{c} \right).$$

Solve the first equation graphically for c by plotting graphs of $y = 5x/4$ and $y = \sinh x$, where $x = 40/c$. Substitute this value for c in the second equation and determine f .

210. The following equations give the voltage E_s and the current I_s required at the sending end of a cable to yield a voltage E_r and current I_r at the receiving end:

$$E_s = E_r \cosh (L \sqrt{rg}) + I_r \sqrt{\left(\frac{r}{g}\right)} \sinh (L \sqrt{rg}),$$

$$I_s = I_r \cosh (L \sqrt{rg}) + E_r \sqrt{\left(\frac{g}{r}\right)} \sinh (L \sqrt{rg}),$$

where L is the length of the line in miles and r and g are constants for the line.

If $r = 20$ ohms per mile, $g = 0.000,02$ mho per mile, $E_r = 100$ volts, and $I_r = 0.2$ amp., show that these equations become

$$E_s = 100 \cosh 0.02L + 200 \sinh 0.02L,$$

$$I_s = 0.2 \cosh 0.02L + 0.1 \sinh 0.02L.$$

a. Compute E_s and I_s , each correct to three significant figures, when $L = 10$ miles and when $L = 100$ miles.

b. Sketch graphs of E_s and I_s as functions of L for L from 0 to 150 miles.

211. Given that $\sinh (a + jb) = \sinh a \cos b + j \cosh a \sin b$,

$$\cosh (a + jb) = \cosh a \cos b + j \sinh a \sin b,$$

compute the values of

$$(a) \quad \sinh (0.785 + j2.87),$$

$$(b) \quad \cosh (0.785 + j2.87).$$

This type of problem occurs in senior electrical engineering courses in both power and communications.

212. A weight rests upon a rough horizontal table at a point, on an assumed set of axes, whose coordinates are $(0, h)$. A string of length h is attached to the weight and the other end is held at the origin. The free end of the string is then pulled along the positive x axis and the weight follows along a curved path whose equation is

$$x = h \operatorname{sech}^{-1} \left(\frac{y}{h} \right) - \sqrt{h^2 - y^2}.$$

Show that this equation can be written in dimensionless-variable form, $X = x/h$ and $Y = y/h$, as

$$X = \operatorname{sech}^{-1} Y - \sqrt{1 - Y^2}.$$

Sketch this last equation by the addition of abscissas. The curve is called a "tractrix."

POLAR COORDINATES

213. Secure either a picture or an actual chart from a recording pyrometer and study it. The radius represents temperature, and the angle is marked in units of time.

214. A block weighing 10 lb. rests on a horizontal surface for which the coefficient of friction is 0.3. A force P , inclined at an angle θ with the horizontal (Fig. 69), acts on this block and is just enough to cause motion of the block to impend. The value of P is given by the equation

$$\frac{3}{P} = \cos \theta - 0.3 \sin \theta.$$

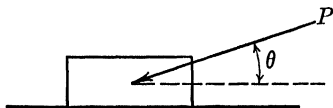

FIG. 69.

a. Sketch a graph in rectangular coordinates of $1/P$ as a function of θ .

b. Sketch a graph in polar coordinates of $1/P$ (radius vector) as a function of θ .

c. Is there any value of θ (acute) for which P is infinite, and hence $1/P$ zero? If so, locate on each sketch.

215. A cam is to be built with a cross section defined by

$$\rho = 4 + 2 \cos \theta \text{ in.}$$

Sketch the cross section of the cam and also the "layout" curve, *i.e.*, the curve whose rectangular coordinate equation is

$$y = 4 + 2 \sin x.$$

216. Antenna radiation patterns, such as can be found in modern radio textbooks, may be plotted from equations such as the following:

$$F(\theta) = \frac{\cos \left(\frac{\pi}{2} \cos \theta \right)}{\sin \theta},$$

$$F(\theta) = \frac{\sin (\pi \cos \theta)}{\sin \theta},$$

$$F(\theta) = \frac{\sin (2\pi \cos \theta)}{\sin \theta}.$$

a. Plot each of these graphs on polar coordinate graph paper.

b. Plot each of these on rectangular coordinate graph paper using θ as abscissa and $F(\theta)$ as ordinate. Plot for $0 < \theta < 2\pi$.

217. Assignment for a mechanical engineering student: Secure from your engineering library a copy of a textbook on machine design. Look over the discussion on cams and layouts and take the textbook to class to show the diagrams to the other members of the class.

218. a. Sketch the polar coordinate graph for $\rho = e^{-0.04\theta}$ for the range from $\theta = 0$ to $\theta = 25$.

b. Let OP be a vector with O at the pole and P some point on the curve drawn in part (a). Show that the horizontal component of OP is

$$x = e^{-0.04\theta} \cos \theta.$$

c. Now suppose that OP rotates about O with an angular speed of 2π radians per second so that $\theta = 2\pi t$ radians. The preceding equation becomes

$$x = e^{-0.251t} \cos 2\pi t.$$

Sketch the rectangular coordinate graph of x as a function of t as t increases from 0 to 8 sec.

Remark: This concept of a rotating vector is used in texts on vibrations to discuss damped free vibrations. If the vibration were undamped, the point P would move along a circle instead of along the spiral drawn for part (a). This problem may also be interpreted in terms of a transient alternating current.

PARAMETRIC EQUATIONS

219. A particle moves in a counterclockwise direction around a circle of radius 10 in., starting at the right end of the horizontal diameter. At the end of t sec. the particle has moved through $s = 4t^2$ in. Determine the parametric equations for x and y in terms of t (the abscissa and the ordinate measured from the center of the circle).

220. A railway easement curve (used to join a straight track to a uniform or circular track) has the following parametric equations when designed for a speed of 33 miles per hour. Plot, taking u at intervals of 0.1 from 0 to 1.

$$x = 600 \left(u - \frac{u^5}{10} \right) \text{ ft.},$$

$$y = 200 \left(u^3 - \frac{u^7}{14} \right) \text{ ft.}$$

221. A point on the rim of a wheel of radius 2 ft. moves in such a way that its coordinates (referred to axes through the center of the wheel) are always given by $x = 2 \cos 3t$ ft., $y = 2 \sin 3t$ ft. The velocity at any time t sec. in the x direction is given by $v_x = -6 \sin 3t$ ft. per sec. and in the y direction by $v_y = 6 \cos 3t$ ft. per sec.

Plot the curve in polar coordinates (r, θ) which is given in parametric form by $r^2 = v_x^2 + v_y^2 = (-6 \sin 3t)^2 + (6 \cos 3t)^2$ and $\tan \theta = v_y/v_x$. Label the points on your graph which correspond to $t = \pi/6, \pi/3, \pi/2$, and $2\pi/3$ sec. ($t = 0$ corresponds to $\theta = \pi/2, r = 6$).

Remark: In mechanics the polar coordinate curve plotted in this problem is called the "hodograph" for the given motion. It will be defined in that course.

222. A point moves around a curve whose parametric equations are $y = 16 - t^4$ ft., $x = t^2$ ft., where t is in seconds. $v_x = 2t$ ft. per sec. and $v_y = -4t^3$ ft. per sec. (See Prob. 221 for the meaning of v_x and v_y .)

a. Sketch the graph of the given motion curve. Locate those points which correspond to $t = 0$, $t = 0.5$, and $t = 1$ sec.

b. Sketch the curve in polar coordinates whose polar parametric equations are $r^2 = v_x^2 + v_y^2$, $\tan \theta = v_y/v_x$. Locate the points on this second curve that correspond to $t = 0$, 0.5 , and 1 sec.

Note: When $t = 0.1$, $r = 0.2$ and $\theta = -1^\circ 9'$.

c. At the point that corresponds to $t = 1$ sec. in the second graph, draw the tangent line by aid of a straightedge and compute its slope.

223. Figure 70 shows a crank arm OB of radius r , which rotates counterclockwise with a constant angular speed of ω radians per second.

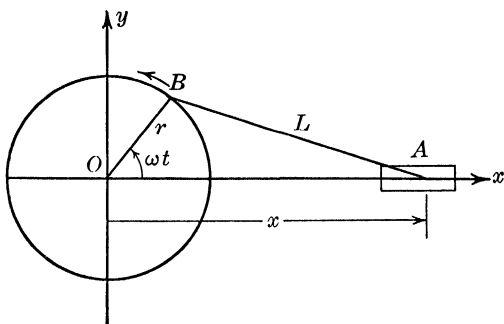

FIG. 70.

A connecting rod BA has a length of L ft. and the end A moves up and down the x axis. Assume that $r/L = 1/5$.

a. Determine the parametric coordinates for the point B as a function of the time t sec., measured from the time B was at the right-hand end of the horizontal diameter of the circle.

b. Show that the abscissa for the point A is always given by

$$x = r \cos \omega t + (L^2 - r^2 \sin^2 \omega t)^{1/2} \text{ ft.}$$

c. Let $z = \cos \omega t$. Show that the result in part (b) can then be written as

$$x = rz + \sqrt{L^2 - r^2 + r^2 z^2} = 0.2Lz + L \sqrt{0.96 + 0.04z^2}.$$

Sketch x/L as a function of z . (Observe that z can vary only between -1 and $+1$ and also that the sign in front of the square root is to be positive.)

d. What are the parametric equations for the curve which the mid-point of the connecting rod traverses? Eliminate the parameter and sketch this curve by the method of addition of abscissas.

224. Observing a point on a vibrating pedestal of a rotating machine through a microscope reveals that such a point usually describes an

elliptic curve as illustrated in Fig. 71. This ellipse may be considered as caused by simultaneous harmonic motions in the horizontal and vertical directions (Lissajous figure). The vertical and horizontal motions have a certain phase displacement α with respect to time.

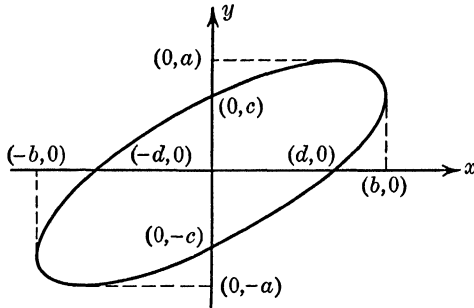

FIG. 71.

a. Determine A , B , and α so that the parametric equations for the ellipse are

$$x = A \cos \omega t, \quad y = B \cos (\omega t - \alpha).$$

b. Determine a condition on the given dimensions (a, b, c , and d) so that this type of motion will be possible.

225. Graph the following Lissajous figures (see Prob. 224):

- (a) $x = \sin 2\pi t, \quad y = 2 \cos \pi t;$
 (b) $x = a \sin 3\pi t, \quad y = b \sin 2\pi t;$
 (c) $x = 6 \sin 2\pi t, \quad y = 8 \sin \left(2\pi t - \frac{\pi}{3} \right).$

226. A cylindrical water tank is to be kept full of water. At a distance of 9 ft. below the top of the tank is a small circular opening. The water is allowed to start flowing out of this hole. It is known, from fluid mechanics, that the path of the water is a parabola (to a good approximation) with its vertex at the hole.

If the origin is taken at the hole, x measured in feet outward from the hole, and y measured in feet downward from the hole, the parametric equations for the water path are

$$y = \frac{gt^2}{2}, \quad x = vt,$$

where g is approximately 32.2 ft. per sec. per sec. and v is the speed of the water as it leaves the hole.

a. Eliminate t and sketch the curve.

b. If $x = 8$ ft., $y = 2$ ft., is a point on the water path, determine the initial speed (v in feet per second).

227. The crank OP in Fig. 72 is 10 in. long and rotates around O in the plane XOY with a constant angular speed of ω radians per second. $AP = PB = 10$ in., and A and B are free to slide along the x and y axes, respectively. The point M is midway between A and P . Determine the parametric equations for the curves traced by the points P and M . Sketch the curves and identify them.

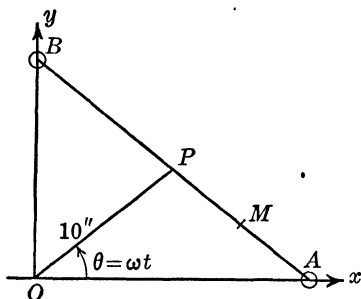

FIG. 72.

228. The plate current i_b in milliamperes in a three-element vacuum tube is given in terms of the grid voltage e_c in volts (for an assumed resistance load in the plate circuit) by

$$i_b = 8 + 0.4e_c + 0.005e_c^2.$$

A sinusoidal voltage, $e_c = -20 + 20 \sin \theta$ where $\theta = 1,000\pi t$, is impressed in the grid circuit.

a. Show that the equation for i_b in terms of θ is

$$i_b = 3 + 4 \sin \theta - \cos 2\theta,$$

and sketch i_b as a function of θ on rectangular-coordinate graph paper.

b. Usually the i_b - e_c relationship is available in graphical and not

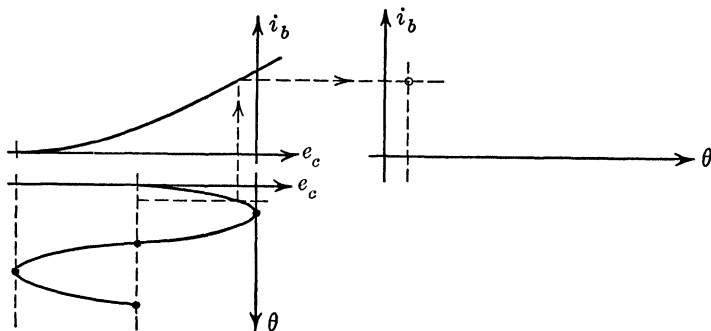

FIG. 73.

algebraic form. Hence a graphical method should be used to obtain the required graph. The graphical method is described below and the student is asked to perform the indicated graphical steps and to obtain approximately the same graph as he obtained in (a).

First plot i_b in terms of e_c . Then plot the graph of e_c in terms of θ and divide the interval from $\theta = 0$ to $\theta = 2\pi$ into any convenient number of equal parts, say 12. Construct axes for the graph of i_b in terms of θ , and lay off these 12 division points on the θ scale. Find the i_b

point that corresponds to each e_c point graphically, as suggested in Fig. 73. Then sketch the required graph.

Note: The i_b-e_c graph is zero for e_c to the left of the e_c intercept (vertex in this case). The instructor can vary this problem by changing the impressed voltage. If $e_c = -30 + 20 \sin \theta$, the result will be a "blocked" wave. If $e_c = -40 + 10 \sin \theta$, another "blocked" wave will result.

229. A conchiodograph consists of a rod AB , one end of which moves in the slot DE (the x axis) and the other end passes through a pivoted guide at N . The distance between the slot DE and the pivot at N is a . M_1 and M_2 are points on the rod such that $AM_1 = a$ and $AM_2 = a/2$. Determine the parametric equations for the curves which M_1 and M_2 describe and eliminate the parameter in each case (see Fig. 74).

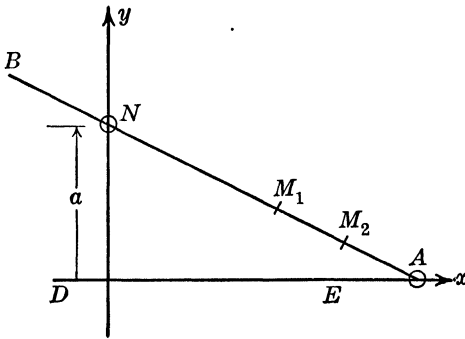

FIG. 74.

***230.** The magnetic field quantities B and H are related (in iron-core transformers or inductances) by a curve of the form shown in Fig. 75. This figure is called a hysteresis loop. The branch or part abc gives the values when B increases; branch cda when B decreases,

a . If B , caused by an alternating voltage (in a transformer, for example), is given (in gauss) as a function of time by

$$B = 10,000 \cos 120\pi t,$$

plot the curve for H as a function of time. (The magnetizing current is proportional to H .) This plot is to be obtained in the following way: Let $\theta = 120\pi t$. When $\theta = 0$, $B = 10,000$ and the point on the hysteresis loop is at c . Plot $H = 1.92$ when $\theta = 0$. Now as θ increases from 0 to π , B decreases from 10,000 to $-10,000$ and the point is moving along the branch cda . Compute a number of values for B for assigned values of θ , read the corresponding values of H from the loop graph, and plot these in terms of the assigned values for θ . The values for H as θ changes from π to 2π are to be read from the loop branch abc (since B is now increasing).

b. Sometimes it is convenient to approximate the graph of H as a function of time by an equation of the form

$$H = H_m \cos(\omega t + \varphi).$$

Since B in terms of t is given to be of the form $B = B_m \cos \omega t$, eliminate

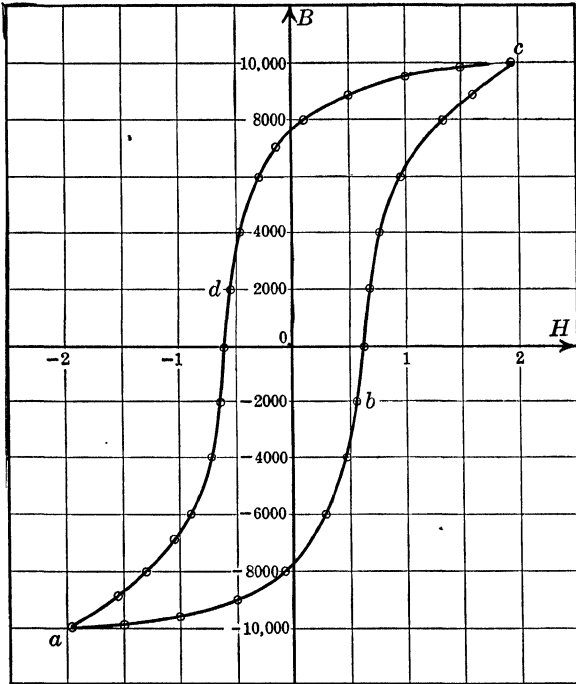

FIG. 75.

the parameter t and show that the hysteresis loop for this hypothesis is an inclined ellipse. Notice that B_m , H_m , ω , and φ are constants.

EMPIRICAL CURVES

231. The data given below were taken on a compressive test of a concrete cylinder with diameter 6 in. and height 12 in. s is unit stress in pounds per square inch (total load divided by the area) and ϵ is the unit strain in inches per inch (total amount compressed divided by original height). Let $K = 10,000\epsilon$.

K	0	1.10	3.58	5.00	6.25	8.10	10.60	15.00
s	101	430	1,250	1,700	2,030	2,460	2,840	3,090

Use the method of averages to determine a , b , and c if

$$s = a + bK + cK^2$$

and then transform the equation to one in terms of s and ϵ . Estimate the highest point on the curve.

232. A portion of the stress-strain curve showing the results of a tension test of a mild steel bar is given by the following data. s is unit stress in pounds per square inch and ϵ is the unit strain in inches per inch. Let $S = 0.001s$.

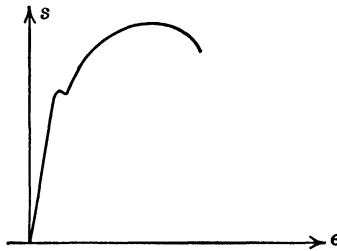

FIG. 76.

S	0	7.5	14.1	19.8	25.0	31.1	35.0	37.2	37.5
ϵ	0	0.002	0.004	0.006	0.008	0.010	0.012	0.014	0.016

a. Determine, by the method of averages, the value for b if $S = b\epsilon$. Then transform the equation to $s = 1,000b\epsilon$. The value of $1,000b$ has very important physical significance. It is the slope of the straight-line part of the graph and is the modulus of elasticity of the material (denoted by E in engineering notation).

b. Determine, by the method of averages, the values of a , b , and c if $S = a + b\epsilon + c\epsilon^2$ and then transform the equation by aid of $S = 0.001s$. Estimate the largest value for s .

233. The following data were obtained from a filter-press experiment in a chemical engineering laboratory. V is volume in liters that has been filtered at the end of θ sec.

V	0.5	1.0	1.5	2.0	2.5	3.0	3.5	4.0	4.5
θ	6.3	14.0	24.2	37.0	51.7	69.0	88.8	110.0	134.0

a. Determine empirically the values of a , b , and c so that θ will be represented as a quadratic function of V ; *i.e.*, $\theta = aV^2 + bV + c$.

b. Transform your resulting equation to the form

$$(V + V_c)^2 = k(\theta + 0_c).$$

V_c is a "mythical" volume that is due to the filter cake and the effect of the filter cloth.

234. The following data give i_b in terms of e_c for a vacuum tube as described in Prob. 228.

e_c	-20	-16	-12	-8	-4	0
i_b	0.1	0.7	1.4	2.2	3.1	4.2

a. Form a difference table and show that i_b can be expressed to a good approximation as a quadratic function of e_c .

b. Determine a , b , and c if $i_b = ae_c^2 + be_c + c$.

235. The following data give the discharge Q in cubic feet per second over a rectangular weir for a given head H in feet.

H	0.166	0.509	0.989	1.152	1.792	3.970
Q	0.93	5.58	13.85	17.52	34.05	107.60

The formula for Q is known to be $Q = CLH^n$, where C and n are constants and L is the length of the weir in feet and is 4.26 ft. for these data. Determine C and n by the method of selected points. C is called the "mean value" of the coefficient of discharge.

236. The electron emission current from a hot filament is found experimentally to vary with temperature as given in the following table. T is absolute temperature in degrees Kelvin, i is the emission

T	1400	1600	1800	2000	2200	2400	2600	2800
i	$6.61(10^{-9})$	$9.51(10^{-7})$	$4.55(10^{-5})$	0.001,003	0.01328	0.1160	0.7160	3.53

current density in amperes per square centimeter. The following equations were found theoretically:

$$i = a \sqrt{T} e^{-b/2T}, \quad i = AT^2 e^{-c/T},$$

the first being the older.

a. Determine the constants for each equation to fit the given data.

b. Compute the residuals and compare the fitting by the two curves.

237. Froelich's equation, $B = aH/(b + H)$, is sometimes used as an analytical representation of the magnetization curve for ferromagnetic materials. Determine a and b so that this equation will fit the data in the following table. Plot a graph using the given data; using the derived equation; compare. In most practical cases the agreement is not close over the whole range of the curve.

H	0	1.0	2.0	3.0	4.0	5.0	6.0	8.0	10.0	15.0	20.0	30.0
B	0	5.00	9.00	10.30	11.32	11.80	12.15	12.69	13.08	13.72	14.18	14.75

238. Assignment for any engineering student: Ask your engineering adviser to suggest a textbook in your chosen field of engineering in which use is made of curve fitting or of graphs on special coordinate paper.

Remark: Use is made in engineering of log log and semilogarithm paper not only for curve-fitting purposes but also to show the graph of a function where one or both variables have large ranges. For example, about 75 per cent of chemical engineering data are plotted on log log paper.

239. For very smooth pipes the following formula relates the Reynolds number R to the frictional factor f for the pipe. (These terms will be defined when you take fluid mechanics.)

$$\log_{10} R = \frac{1}{2\sqrt{f}} - \frac{1}{2} \log_{10} f + 0.40.$$

Texts on fluid mechanics show the graph of this equation on log log paper for a range 0.010 to 0.050 for f and 5,000 to 5,000,000 for R .

a. Plot the graph on log log paper for this range, or plot $\log_{10} R$ as a function of $\log_{10} f$ on ordinary paper.

b. Show that the following method will yield the graph for the given equation. Let $x = \log_{10} f$ and $y = \log_{10} R$. Then the given equation may be written in the form

$$y = \left(\frac{1}{2}\right) (10^{-x/2}) - \frac{x}{2} + 0.40.$$

Use a sheet of log log paper *but* plot y as a function of x (by the method of addition of ordinates) using uniform scales on both x and y axes. This will entail some care that use is not made of the logarithm rulings.

240. Plot on ordinary graph paper and on log log paper the two following equations. Show a range of 0 to 1,000,000 volts for V on the first graph and from 1 to 1,000,000 for V on the second graph.

$$v = 597,000 \sqrt{V},$$

$$v = 300,000,000 \sqrt{1 - \frac{1}{(1 + 0.000,001,95V)^2}}$$

where V is the voltage in volts in an "electron gun" and v is the speed of the particle in meters per second.

Note: The former equation is arrived at from Newtonian theory and provides an excellent approximation for voltages below 10,000 volts. The latter equation comes from modern physics.

ELEMENTARY FORMULAS IN SOLID ANALYTIC GEOMETRY

241. A force of 80 lb. acts along a line directed from (10,0,8) toward (5,3,0).

a. Sketch a figure and show the two points and the given force.

b. Determine the direction cosines and the direction angles for the line of action of this force and label these direction angles on your figure.

c. Determine the components of this force in the x , y , and z directions by multiplying the force 80 lb. by each of the direction cosines in turn.

242. A force of 18 lb. acts from the origin toward (2,1,2). A force of 12 lb. acts from the origin toward (4,4,2).

a. Sketch a figure, show these two forces as vectors properly directed and scaled, and construct their resultant by constructing the parallelogram that has these two given vectors as sides. Draw the diagonal of this parallelogram, which starts at the origin. This diagonal represents the resultant of the two given forces.

b. Determine the x , y , and z components of each force.

c. Determine the sum of the x components of both forces, the sum of the y components, and the sum of the z components. Then determine the vector (in magnitude and direction, *i.e.*, direction numbers or cosines) that has these sums as its x , y , and z components.

d. Determine the acute angle between the given forces, correct to the nearest tenth of a degree.

243. (Similar to Prob. 242.) The following four forces are each directed towards the origin from the point given with each force:

$$F_1 = 100 \text{ lb., } (2,2,1); \quad F_2 = 150 \text{ lb., } (3,2,-2); \\ F_3 = 50 \text{ lb., } (-4,-3,-3); \quad F_4 = 200 \text{ lb., } (0,0,4).$$

a. Sketch a figure and show all four forces.

b. Determine the sums of the x , y , and z components for all four forces. Then determine the resultant (that force which has these sums for its x , y , and z components). Give the magnitude correct to the nearest three significant figures and the direction angles each correct to the nearest tenth of a degree.

244. A horizontal bar ABC supports a load of 1,000 lb. as indicated in Fig. 77. The bar is supported by a ball-and-socket joint at B and by two cables CD and AE . If axes are chosen as shown, the coordinates of D are (14, -6, 12) and of E are (-9, -10, -10). The unit is 1 ft.

The problem in mechanics would be to determine the tensions in the two cables and the reaction at B . You are to study and complete the following solution and notice the use of methods of analytic geometry.

Solution: Let the force or reaction at B have components B_x, B_y, B_z (each assumed to be positive). Assume the tension in CD to be T lb. and that in AE to be P lb. The $x, y,$ and z components of these tensions

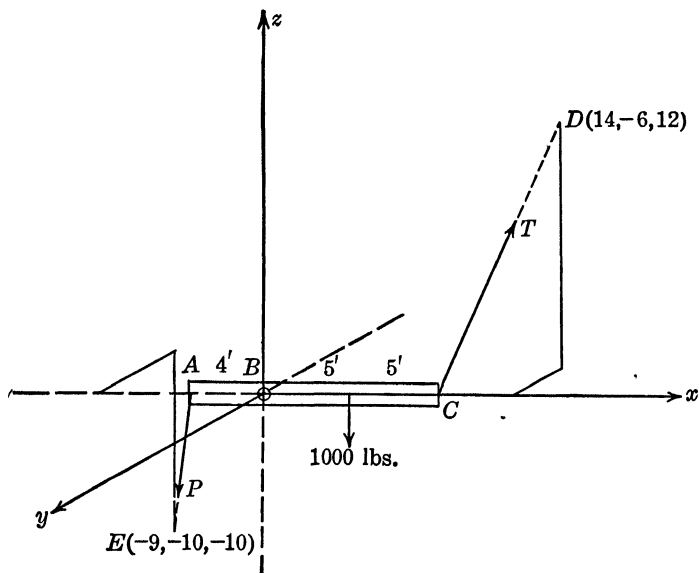

FIG. 77.

are determined by multiplying the tension by each of the direction cosines of the line segment. Thus the components are found to be

$$\frac{2T}{7}, -\frac{3T}{7}, \frac{6T}{7}; -\frac{P}{3}, -\frac{2P}{3}, -\frac{2P}{3}.$$

The sum of the forces in the x direction must be zero and also the sum of the forces in the y and z directions. Hence

$$\Sigma F_x = 0:$$

$$\frac{2T}{7} - \frac{P}{3} + B_x = 0,$$

$$\Sigma F_y = 0:$$

$$-\frac{3T}{7} - \frac{2P}{3} + B_y = 0$$

$$\Sigma F_z = 0:$$

$$\frac{6T}{7} - \frac{2P}{3} + B_z - 1,000 = 0.$$

The sum of the "moments (turning effects) with respect to each axis" must be zero. (The moment of a force is the product of that force and the perpendicular distance from the axis to the line of action of that force.) This yields

$$\Sigma M_x = 0:$$

$$0 = 0,$$

$$\Sigma M_y = 0:$$

$$5,000 - \frac{60T}{7} - \frac{8P}{3} = 0,$$

$$\Sigma M_z = 0:$$

$$\frac{8P}{3} - \frac{30T}{7} = 0.$$

Solve these two sets of equations simultaneously.

245. The following data give the dimensions in inches of half an airplane landing gear. Compute the lengths and direction cosines for each member and sketch the half gear.

Point	Coordinates		
	x	y	z
<i>A</i>	10	0	0
<i>B</i>	-30	-20	30
<i>C</i>	-6	10	30
<i>D</i>	-6	-40	30
<i>E</i>	-5	0	0
<i>O</i>	0	0	0

The members are *AO*, *BE*, *CO*, *DO*, and *EO*.

246. A street corner is at the base of a hill from both the north and the east direction. The grade of the street north is 20 per cent and that for the east direction is 10 per cent. A water main having the same grades as the streets is to turn the corner. Determine the angle required for the elbow at the turn.

247. Two tunnels start from a common point *A* in a vertical shaft. Tunnel *AB* bears N.60°W., falls 10 per cent and is 300 ft. long. Tunnel *AC* bears S.30°W., falls 12 per cent and is 200 ft. long. The ends of the tunnels are to be connected by a ventilating shaft.

a. Sketch a figure with origin at *A* and determine the x , y , and z coordinates for *B* and *C*.

b. Determine the following quantities for the ventilating shaft:

- (1) The true length, correct to three significant figures.
- (2) Its bearing, correct to the nearest minute, with reference to *B*.

- (3) Its percentage of grade, correct to the nearest tenth of 1 per cent.
 (4) The angle it makes with the horizontal, correct to the nearest tenth of a degree.

248. A vertical mast AB is guyed by three guy wires to anchors at C , D , and E . The distance is 150 ft. up to the point B where the three wires are fastened.

Point C is 60 ft. east, 40 ft. north, and 10 ft. above A ,
 Point D is 80 ft. west, 20 ft. north, and 10 ft. below A ,
 Point E is 10 ft. east, 70 ft. south, and 15 ft. above A .

Determine (assuming the guy wires to be straight):

- The length of each guy wire, correct to three significant figures.
- The angle each guy wire makes with the horizontal.
- The angle each guy wire makes with the east direction and with the north direction.

249. Points A , B , and C are points of outcrop of a vein of ore. A is 450 ft. north and 300 ft. west of B and has an elevation of 2,500 ft.; C is 100 ft. north and 250 ft. east of B and has an elevation of 2,200 ft.; and the elevation of B is 2,700 ft. Point D , not on the vein, is 400 ft. north and 150 ft. east of B and has an elevation of 2,600 ft.

It is desired to drive the shortest possible tunnel from D to the vein. Determine the following:

- The coordinates of A , B , C , D referred to x , y , z axes chosen in a convenient manner. (One such choice would be to take z upward, x positive in the east direction, and y positive in the north direction.)
- The equation of the plane ABC .
- The perpendicular distance from D to that plane and the direction cosines and angles for that perpendicular.

250. Two mining shafts AB and CD are determined by $A(0,0,0)$, $B(800,600,-800)$, $C(100,900,-600)$, $D(700,100,-100)$.

- Sketch a figure and show the two shafts.
- Show that a set of parametric equations for the shaft AB are $x = 800t$, $y = 600t$, $z = -800t$; for CD the equations are $x = 100 + 600s$, $y = 900 - 800s$, $z = -600 + 500s$.
- Determine the length of the tunnel joining the point on the shaft AB that corresponds to $t = t$ to the point on CD that corresponds to $s = s$. Also determine expressions for the direction numbers for this line segment.
- If the tunnel in (c) is level, show that $8t = 6 - 5s$ and hence that the length of the tunnel can be reduced to

$$L = 25 \sqrt{2,225s^2 - 2,372s + 724}.$$

- Identify and sketch a graph of L as a function of s . What value of s gives the smallest positive value for L ? What are the coordinates of the ends of the tunnel for this value of s ?

SURFACES IN SOLID ANALYTIC GEOMETRY

251. Plot a careful graph for the gas law: $pv = kT$, where p is pressure, v is volume, T is absolute temperature, and k is a constant. Use 1 in. equal to one unit on the v axis (positive to the right), $\frac{3}{4}$ in. equal to one unit on the v axis (positive perpendicular to your sheet of graph paper), and 1 in. equal to $1/k$ units on the T axis (positive upward). Give a careful discussion about the traces in the coordinate planes and in planes parallel to the coordinate planes and answer the following questions:

- What traces on the graph correspond to Boyle's law?
- Charles's law has two different parts. What are these and to what traces do they correspond?
- Show that the trace of this surface in the plane $p = v$ is a parabola.
- If axes in the p - v plane are rotated through an angle of 45° about the T axis so that the new variables x, y are given by

$$p = \frac{x - y}{\sqrt{2}}, \quad v = \frac{x + y}{\sqrt{2}},$$

show that the equation becomes $x^2 - y^2 = 2kT$ or, if $z = 2kT$, $x^2 - y^2 = z$. Identify this quadric surface.

252. Sketch the surface $E = Ir$ (Ohm's law in electrical engineering). Will your same graph do for the equation $P = EI$ (another equation from electrical engineering)?

253. Will your graph for Prob. 252 do for the graph of the important beam equation $s = M(c/I)$ or for the important equation for torsion $s = T(c/J)$, if c is a constant? Both these equations will be derived when you study strength of materials.

Remark: The three preceding problems indicate how widely diverse engineering problems or theory may have a common mathematical discussion.

254. When water flows turbulently through a rough pipe, the speed at any distance from the center of the pipe (of radius R) is given closely by the following rule: Let the speed at the center (the maximum value) be V_m . Then the speed at a distance r from the center of the pipe is the ordinate to a surface of revolution: The bottom part of the surface is a cylinder of radius R and height $V_m/2$. The top part is half an ellipsoid of revolution whose semiaxes are $R, V_m/2$, and R .

- Show that the speed at a distance r from the center is given by

$$V = \frac{V_m}{2} \left(1 + \sqrt{1 - \frac{r^2}{R^2}} \right).$$

- Sketch the surface.
- Sketch a graph of V/V_m as a function of r/R and explain the relation of this plane graph to the surface.

255. Refer to prob. 446 and sketch the surface described in the first paragraph of that problem. Assume $2b = 1.50$ in. and $2a = 0.75$ in.

256. Airy's stress function for the torsion (twisting) in a bar with an elliptical cross section (semimajor and semiminor axes a and b , respectively) is

$$\varphi = \left(\frac{M}{\pi ab} \right) \left(1 - \frac{x^2}{a^2} - \frac{y^2}{b^2} \right),$$

where M is a positive constant.

a. Determine the value of φ for points on the boundary of the ellipse.

b. Sketch a graph of the surface. Show only that portion for which φ is positive.

257. A grain elevator has a rectangular hopper 12 by 20 in. and a circular feed pipe with diameter 16 in. The axis of the pipe and the hopper coincide, but the end of the pipe is 30 in. above the hopper. Sketch the setup and show a connecting pipe that is circular on one end and rectangular on the other.

Suppose the circular end is in the plane $z = 30$, the rectangular end in the xy plane, and the common axis is the z axis. Suppose the rectangular end in the xy plane has its vertices at $(10,6,0)$, $(10,-6,0)$, $(-10,-6,0)$, and $(-10,6,0)$. Show that a portion of the connecting pipe could have for its equations in parametric form the following:

$$\begin{aligned} x &= 10 + t(8 \cos \theta - 10), \\ y &= 10 \tan \theta + t(8 \sin \theta - 10 \tan \theta), \\ z &= 30t, \end{aligned}$$

where t can vary from 0 to 1 and θ from $-\tan^{-1}(3/5)$ to $+\tan^{-1}(3/5)$. Discuss the section when $t = 0$, when $t = 0.5$, and when $t = 1$. Would this be a reasonable way to design the connecting pipe? Should the connecting pipe be a "ruled surface"?

258. An equation used in strength of materials is

$$\frac{X^2}{\sigma_x^2} + \frac{Y^2}{\sigma_y^2} + \frac{Z^2}{\sigma_z^2} = 1.$$

where the quantities in the three denominators are constants. Would the name *ellipsoid of stress* be a reasonable name, assuming that the equation has something to do with stress? Sketch the surface.

259. Let O be the North Pole of the earth (assumed a sphere with radius R). Let A be any point on the surface of the earth and let the line OA intersect the plane of the equator at point P . Assume the origin at the center of the earth and the z axis through the North Pole. Show that the coordinates of the point P are $x_P = x_A R / (R - z_A)$, $y_P = y_A R / (R - z_A)$, and $z_P = 0$, where (x_A, y_A, z_A) are the coordinates of point A .

Note: The method of "projection" indicated in this problem is the basis for a Mercator map of the earth.

260. In Prob. 259, suppose that the point O is at the center of the earth and, instead of using the equatorial plane, that we use a plane tangent to the earth at the North Pole (it could be tangent at any point on the earth for the purposes of the projection). If the line OA intersects this tangent plane at the point P , show that the coordinates of the point P are

$$\bullet \quad x_P = \frac{x_A R}{z_A}, \quad y_P = \frac{y_A R}{z_A}, \quad z_P = R.$$

Note: This problem forms the basis for a gnomonic type of map of the earth.

***261.** For a map of the earth, as indicated in Prob. 260, show that every great circle on the earth projects into a straight line on the tangent plane or gnomonic map.

Note: The converse of the statement of this problem is also true. This property makes the use of gnomonic maps of great importance in charting courses.

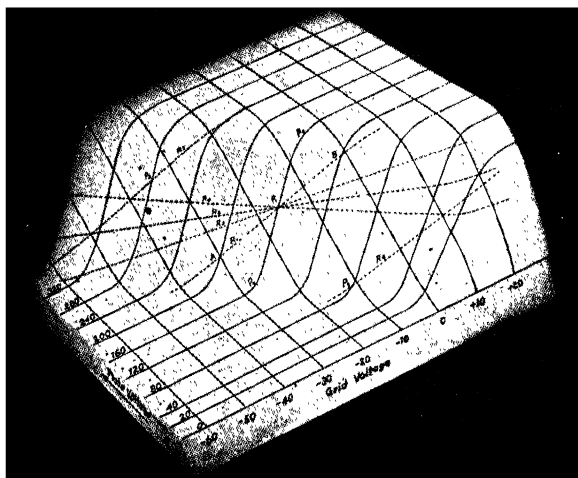

FIG. 78.

262. Figure 79 shows a "contour map" of a surface, such as is shown in Fig. 78. The surface represents grid voltage e_c and plate voltage e_b plotted in the horizontal plane and plate current i_b along the vertical axis.

a. Plot a second contour map showing the contours for various values of e_b .

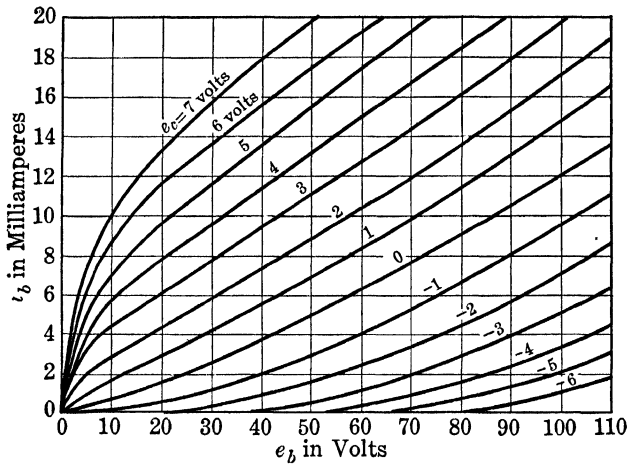

FIG. 79.

b. Plot a third contour map showing the contours for various values of i_b .

PART IV
DIFFERENTIAL CALCULUS

USES AND INTERPRETATIONS OF DERIVATIVES

263. If specific heat is defined to be dQ/dt , where Q is the quantity of heat necessary to raise the temperature of 1 gram of a substance from 0 to $t^\circ\text{C}$. and if for ethyl alcohol

$$Q = 0.5068t + 0.001,43t^2 + 0.000,001,8t^3$$

(valid for the range from 0 to 60°C .), determine the specific heats of ethyl alcohol at $t = 10^\circ\text{C}$., 20° , 30° , 40° , and 50° .

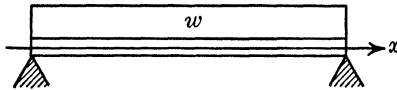

FIG. 80.

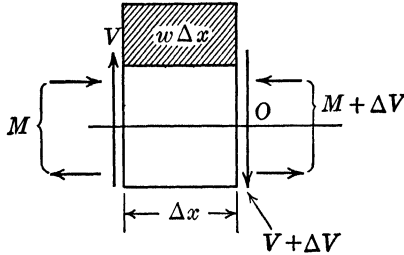

FIG. 81.

***264.** A section of a beam is shown in Fig. 81. The beam (Fig. 80) is loaded with a uniform load of w lb. per ft. and with some concentrated loads whose magnitudes and positions are not shown. (The quantities M and V will be defined in strength of materials.) If one equates to zero the "first moment" of all the forces with respect to the point O , one obtains

$$M + V \Delta x - (w \Delta x) \left(\frac{\Delta x}{2} \right) + (M + \Delta M) = 0.$$

Simplify, divide by Δx , and obtain

$$\frac{\Delta M}{\Delta x} = V - \frac{w \Delta x}{2} . .$$

Let Δx approach zero and obtain

$$\lim_{\Delta x \rightarrow 0} \frac{\Delta M}{\Delta x} = \frac{dM}{dx} = V.$$

Remark: In the language of strength of materials, this equation states that, "The rate of change of bending moment M with respect to the distance (measured from some point on the beam) is equal to the vertical shear V ." Or, "The derivative of bending moment with respect to x is equal to the shear."

Notice that this derivation, while containing the language and notation of the course in strength of materials, is the important delta process of differential calculus.

265. If $V = dM/dx$ and if

$$M = \frac{2Px}{7} \text{ for } 0 < x < 10 \quad (P \text{ is a positive constant}),$$

$$M = 10P - \frac{5Px}{7} \text{ for } 10 < x < 14,$$

- Sketch a graph of M/P as a function of x for x from 0 to 14.
- Determine V for $0 < x < 10$ and for $10 < x < 14$. Then sketch the graph for V/P as a function of x for x from 0 to 14.
- Does the graph of V as a function of x have a discontinuity in the range $0 < x < 14$?

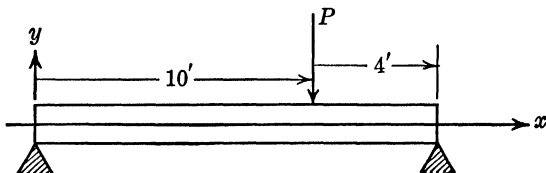

FIG. 82.

Remark: The beam and loading for this problem are shown in Fig. 82.

The mathematical analysis of such beams gives a shear graph (V as a function of x) with discontinuities at each point where there was a concentrated load. The mathematical analysis of such problems assumes that the concentrated load is applied *at a point* (which is physically impossible). However, the results from this analysis are accurate enough for most purposes.

266. In a resistance of r ohms the current i amp. is given in terms of the voltage (e volts) by the equation (Ohm's law) $i = e/r$. In a condenser (C farads) the relation (on discharge) is

$$i = -C \left(\frac{de}{dt} \right).$$

If $e = E_0 \epsilon^{-t/Cr}$, determine equations for i in terms of t for the case of a resistance and for the case of a condenser (C , r , and E are constants). (ϵ is the letter used in electrical engineering for 2.71828 . . .)

Sketch graphs of e as a function of t/Cr , i as a function of t/Cr for both the resistance and condenser cases.

267. "Power" is defined as the rate of doing work with respect to time. If W denotes work, t time, and P power, give the mathematically equivalent definition for power.

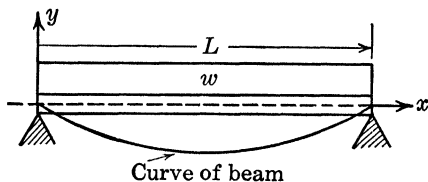

FIG. 83.

268. The beam in Fig. 83 supports a uniform load of w in pounds per foot of beam. If axes are chosen as indicated, the equation of the "curve of the beam" is

$$EIy = \frac{wLx^3}{12} - \frac{wx^4}{24} - \frac{wL^3x}{24},$$

where E , I , w , and L are positive constants.

In strength of materials it will be proved that the "bending moment" is given by $M = EI(d^2y/dx^2)$, the "shear" by $V = dM/dx$, and the load by $EI(d^4y/dx^4)$. Determine M , V , and $EI(d^4y/dx^4)$ for this beam and sketch these three curves (these variables as functions of x) on the same graph.

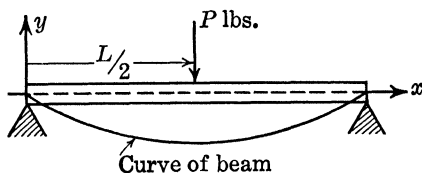

FIG. 84.

269. The beam in Fig. 84 has a concentrated load at mid-span. The "curve of the beam" is given by

$$EIy = \frac{Px^3}{12} - \frac{PL^2x}{16} \quad \text{for } 0 < x < \frac{L}{2},$$

$$EIy = \frac{P(L-x)^3}{12} - \frac{PL^2(L-x)}{16} \quad \text{for } \frac{L}{2} < x < L.$$

Determine $M = EI(d^2y/dx^2)$ and $V = dM/dx = EI(d^3y/dx^3)$ for the entire range from $x = 0$ to $x = L$ and sketch M and V as functions

of x on the same graph. For what value of x is the graph of V as a function of x discontinuous?

270. The "kinetic energy" acquired by a body falling from an infinite distance to a distance r from the center of the earth is given by $W = k/r$, where k is a constant. Determine the force $F = -D_r W$.

271. "Power" is defined as the rate of doing work, i.e.,

$$P = D_t W = \frac{dW}{dt}.$$

If the work being done by a force is $W = 3t^2 + 4t + 6$ (t in seconds and W in foot-pounds), find the power at $t = 2$ sec.

TANGENT AND NORMAL

272. A parabolic arch is 10 ft. high and 20 ft. wide, as shown in Fig. 85. A brace AB is inserted as shown in the figure. Find its length.

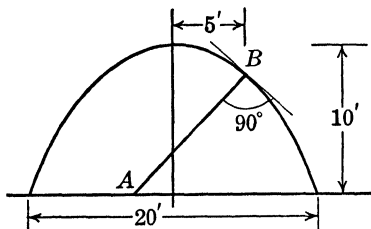

FIG. 85.

273. Euler's column formula from strength of materials is

$$\frac{P}{A} = \frac{\pi^2 E}{(L/r)^2}$$

where P is the total load, A is the cross-sectional area of the column, E is a property of the material from

which the column is made (the modulus of elasticity), L is the length of the column, and r depends on the shape of the cross section.

a. Sketch a graph of P/A as a function of L/r . E is a positive quantity.

b. Determine the equation of the tangent to this curve at the point where $L/r = (3\pi^2 E/p)^{1/2}$, $P/A = p/3$.

Remark: p is the load required to crush the column. Your resulting straight-line equation is known as "the straight-line column formula."

274. Write Euler's column formula (see Prob. 273) in the form $y = a/x^2$, where $y = P/A$ and $x = L/r$, a being a constant. In this same notation, another column formula is of the form $y = b - mx^2$, where b and m are constants. Determine the relation between a , b , and m so that the graphs of these two formulas are tangent, and find the coordinates of the point of tangency.

Note: In the practical design of columns, the second formula is used for values of x from 0 to the point of tangency; the first formula is used for all larger values of x .

275. A catenary is the curve that a cable assumes when hanging between two supports. If the two supports are of equal height and

are at $x = -a$ and $x = +a$, the equation for the curve is

$$y = c + k \cosh \left(\frac{x}{a} \right) = c + \left(\frac{k}{2} \right) (e^{x/a} + e^{-x/a}).$$

Determine an expression for the angle that the cable makes with the vertical support at $x = +a$.

276. Using the data of Prob. 228,

a. Determine the value of $di_b/d\theta = 2$ radians.

b. Determine the equation of the tangent line to the $i_b - e_c$ graph at $e_c = -20$.

277. Using the data of Prob. 146, show that the two equations have the same first derivative value at $x = 8$ ft. and also the same ordinate. Then write the equation of the common tangent line.

278. In constructing a certain type of cam for accelerating a lift, it is necessary to find two parabolas that have a common tangent at points on two given abscissas. Find a and b so that the tangent to $x^2 = ay$ at $x = 2$ shall coincide with the tangent to

$$(x - 10)^2 = b(y - 8.5) \text{ at } x = 9.$$

279. Devise a graphical solution for the common tangent line in Prob. 278 based on the following theorem for parabolas. Also prove the theorem.

THEOREM: The tangent at the vertex of a parabola bisects the segment of any other tangent which is included by the principal axes and the point of tangency.

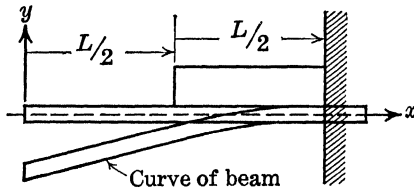

FIG. 86.

280. A cantilever beam of length L ft. bears a uniform load of w lb. per ft. for the length $L/2$ ft. next to the wall as shown in Fig. 86. The equation for this part of the "curve of the beam" is

$$EIy = -\frac{wx^4}{24} + \frac{wLx^3}{12} - \frac{wL^2x^2}{16} + \frac{wL^3x}{24} - \frac{wL^4}{48};$$

i.e., this equation is valid for x between $L/2$ and L . If the weight of the beam itself is neglected, the part of the beam to the left of this load will be straight and will be along the tangent to the preceding curve at the point whose abscissa is $x = L/2$.

Determine the maximum deflection; *i.e.*, find the largest numerical value of y in the entire range (which is clearly the ordinate at $x = 0$).

281. A rock is tied to the end of a string of length 3 ft. and is whirled in a clockwise direction, and the free end of the string is held steady at a certain point. If the origin is taken at the point where the free end is held and if the string breaks when the string makes an angle of $+135^\circ$ with the horizontal (right-hand direction is positive), determine the equation of the path that the rock will take for a short time (neglecting the effect of gravity).

282. In mechanics, the ellipse whose equation is

$$\frac{x^2}{R_y^2} + \frac{y^2}{R_x^2} = 1$$

is called the ellipse of inertia of a plane lamina referred to axes through the origin. R_x and R_y are known as the principal radii of gyration with respect to the x and y axes. Find the equations of the tangents to this ellipse which are parallel to the line $y = mx$. Express the square of the distance between one of these tangents and the line $y = mx$ in terms of m , R_x , and R_y . (This perpendicular distance is the radius of gyration for the axis or line whose equation is $y = mx$.)

283. The point (x_0, y_0) is in the plane of the ellipse described in Prob. 282. Two tangents are drawn to the ellipse and their points of tangency are connected by a straight line. Show that the equation of this line is

$$\frac{xx_0}{R_y^2} + \frac{yy_0}{R_x^2} = 1.$$

Note: The line $xx_0/R_y^2 + yy_0/R_x^2 = -1$ has an interesting association in the study of a vertical column bearing an axial load which is eccentrically placed, *i.e.*, is placed at (x_0, y_0) . It is known as the line of "zero stress" or the line of "stress reversal." The areas of the column sections on opposite sides of this line are, respectively, in tension and compression.

284. If the current flowing in an electric circuit is given by

$$i = Ie^{-at},$$

where I and a are positive constants, determine the length of the subtangent to this curve at the time $t = 0$.

Remark: This result is of importance in electrical engineering. It is called the "time constant" T of the electric circuit and has the following properties:

1. It is the length of the subtangent at $t = 0$.
2. It is the time required for the ordinate (current) to change from an arbitrary value A to the value A/e (a decrease of about 60 per cent). In an interval equal to $3T$ the ordinate decreases from A to A/e^3 , *i.e.*, to about

5 per cent of the value at *A*. Five time constants of time would reduce the current to about 0.67 per cent of the value at the beginning of that time interval. Since this last result is often negligible as compared to the starting value by ordinary standards of engineering accuracy, the following statement is apparent: "The duration of the current, if of exponential form, is five time constants."

3. The time constant is the time it would take *i* to reduce to zero if *i* decreased at a constant rate equal to the rate at which *i* is decreasing when *t* = 0.

4. The area of the rectangle whose base is the time constant and whose altitude is along the *i* axis from *i* = 0 to *i* = 1 is equal to the area under the curve *i* = *Ie^{-at}* in the first quadrant.

Prove that properties 2 and 3 are true. Property 4 can be established after you have studied integral calculus.

*285. A rhumb line on a polar gnomonic chart (see Prob. 260) has the equation

$$\rho = ke^{-c\phi},$$

where *c* is a constant specifying the course traveled, *k* is a constant related to the scale of the map, and ϕ is a meridian of longitude. Show that this rhumb line makes equal angles with the radial lines on the map given by $\phi = \text{constant}$.

286. When benzene vapor is dissolved from flue gas by oil, it is found that

$$y = \frac{Hx}{P - (H - p)x},$$

where *x* is the concentration of the benzene in the liquid and *y* is the concentration of the benzene in the flue gas. *P* is the total force and *H* is Henry's constant in Henry's gas law.

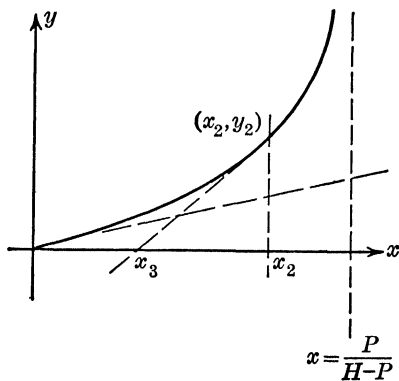

FIG. 87.

a. Sketch a graph for *y* in terms of *x*, assuming that

- (1) *H* is larger than *P*,
- (2) *H* is smaller than *P*.

b. Use your curve for *H* > *P* and determine the slope (*dy/dx*) at *x* = 0, and then the equation of the tangent line at this point. What is the ordinate to this line at *x* = *x*₂?

c. Determine the equation of the tangent to the curve for *H* > *P* at (*x*₂, *y*₂) as determined in (b). What is the *x* intercept, *x*₃, for this second tangent line?

Remark: The tangent line as described in (b) is called the "operating line" in chemical engineering terminology.

*287. In designing rolled products it is necessary that the rolled contours be very accurately constructed. For the U section shown in Fig. 88 determine the x and y coordinates of the center (each to the nearest 0.001 in.) of the 1-in. end miller.

Arc AB is circular with radius 10 in. Arc BC is made by the miller with diameter 1 in., and straight line CD makes an angle of 10° with the horizontal.

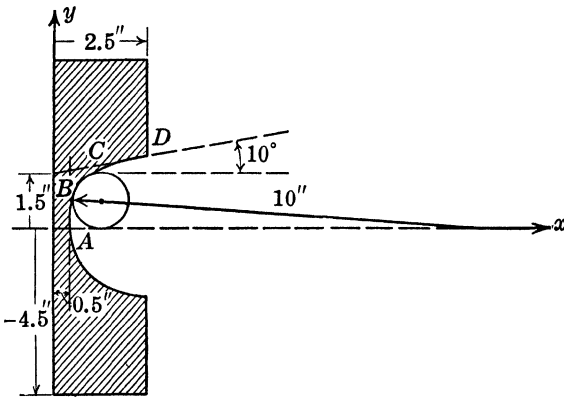

FIG. 88.

CURVE SKETCHING. MAXIMUM, MINIMUM, AND FLEX POINTS

288. A simply supported beam of length 12 ft. weighs 100 lb. per ft. and is loaded with concentrated loads of 2,000 lb. at 3 ft. from the left support, 4,000 lb. at 6 ft., and 6,000 lb. at 7 ft., as shown in Fig. 89.

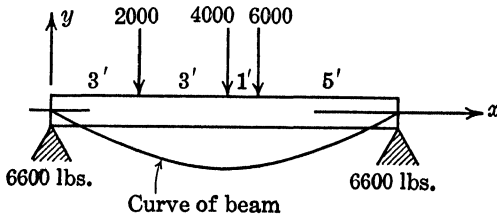

FIG. 89.

The "bending moment" M (to be defined in strength of materials) is given by the following equations:

For $0 < x < 3$:

$$M = 6,600x - 50x^2,$$

for $3 < x < 6$:

$$M = 4,600x + 6,000 - 50x^2,$$

for $6 < x < 7$:

$$M = 600x + 30,000 - 50x^2.$$

for $7 < x < 12$:

$$M = -5,400x + 72,000 - 50x^2.$$

a. Sketch a graph of dM/dx as a function of x for $0 < x < 12$. (This is called the "shear" diagram.)

b. Sketch on the same graph a graph of M as a function of x .

c. If, for the equation of the "curve of the beam," $M = EI(d^2y/dx^2)$, determine the abscissas of the points of inflection. E and I are positive constants.

d. For what values of x is M a maximum or minimum? The requirement in this engineering problem is to determine the *largest* values of M , not merely those for which dM/dx is zero but also those at the end of an interval.

Remark: The answers to (c) and (d) are important in design. The stress at any point in a beam, whether tension or compression, is given by $s = Mc/I$, where c is the distance of the point in question from the "neutral" or centroidal axis and I depends on the shape of the cross section of the beam.

It should be clear that s will be zero at every point along a vertical section through a flex point of the "curve of the beam" and that s will be largest or smallest depending on the behavior of M , and hence of d^2y/dx^2 . E and I are constants.

289. The beam in Fig. 90 supports a uniform load of w lb. per ft. The equation of the "curve of the beam" is

$$EIy = \frac{wLx^3}{12} - \frac{wL^2x^2}{24} - \frac{wx^4}{24},$$

where E and I are positive constants that depend upon the material from which the beam is made and upon its cross section.

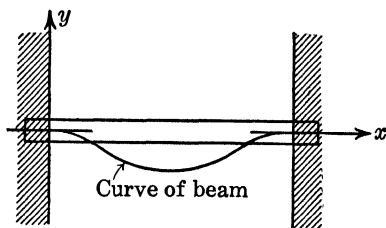

FIG. 90.

a. What is the largest numerical value of $M = EI(d^2y/dx^2)$ and where does it occur?

b. For what values of x does $M = (EI)(d^2y/dx^2)$ equal zero? These are the sections in the beam where the tension or compression is zero.

c. Sketch graphs of EIy/w as a function of x , $(EI/w)(dy/dx)$ as a function of x , M/w as a function of x , and $(1/w)(dM/dx)$ as a function of x . Use a common abscissa but different vertical scales.

290. The electric field intensity on the axis of a uniformly charged ring is found to be $E = Qx / (x^2 + a^2)^{3/2}$, where Q is the total charge on the ring. Also, a and Q are constants (see Fig. 91).

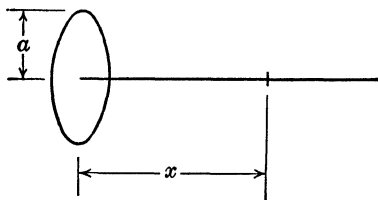

FIG. 91.

- a. Sketch E as a function of x .
 b. At what value of x is E a maximum?
 c. What is the value of x which makes d^2E/dx^2 zero?

Remark: There is need for an understanding of how to sketch the first derivative curve, in general form, directly from the graph of the original equation. Also there is need in engineering for the ability to compute dy/dx by graphical means. These abilities can be developed by problems such as the following two problems.

291. The current i amp. for a condenser of C farads is given in terms of the impressed voltage e volts by the equation

$$i = C \left(\frac{de}{dt} \right).$$

If e is an alternating voltage having the wave form shown in Fig. 92, sketch the wave form for i . C is a positive constant.

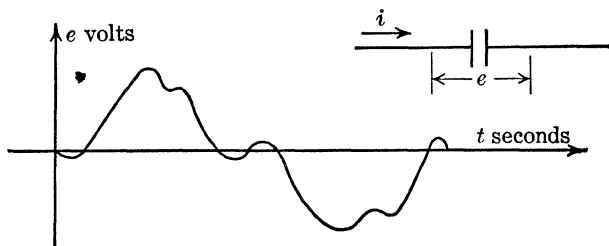

FIG. 92.

292. In the following table

t	0	10	20	30	40	50	60	70
s	0	156	608	1,308	2,180	3,132	4,076	4,942

s is the distance in feet traversed by a body in t sec. (the body moves along a straight line). Plot the graph carefully, draw the tangent lines (to the best of your ability) at each of the given time values, compute the slopes of these tangent lines (ds/dt), and finally plot ds/dt as a func-

tion of t . Use the same abscissas that you used for your original graph but choose the vertical scale so that the resulting graph will be of a reasonable size.

293. An airfoil is to be designed so that it is symmetrical with respect to the x axis, with its nose at the origin, and with its tail toward the right. The equation

$$y = a_0 \sqrt{x} + a_1x + a_2x^2 + a_3x^3 + a_4x^4$$

is to fit the top half of the foil curve and to satisfy the following conditions:

1. The maximum ordinate $y = 0.1$ is to occur at $x = 0.3$ (two conditions implied).

2. The ordinate at the trailing edge $x = 1$ is to be $y = 0.002$.

3. The trailing edge angle is to be such that at $x = 1$, $dy/dx = -0.234$.

4. The ordinate at $x = 0.1$ is to be $y = 0.078$.

Determine the required values for the a 's. Then plot the curve.

294. An airfoil is to be plotted with a "camber" or skewed foil. The mean line of the foil is given by

$$y = \frac{m}{p^2} (2px - x^2) \quad \text{for } x \leq p,$$

$$y = \frac{m}{(1-p)^2} (1 - 2p + 2px - x^2) \quad \text{for } x \geq p.$$

a. Show that the curve is smooth at $x = p$; *i.e.*, that the two equations have a common ordinate and a common tangent line at $x = p$.

b. Plot this curve from $x = 0$ to $x = 1$ on the assumption that $p = 0.3$ and $m = 0.06$.

c. Now plot the airfoil itself according to the following directions: Locate any point on the mean line curve, for example, at $x = 0.1$ and $y = 0.033$. Draw a perpendicular to the mean line curve at this point. Now compute y for $x = 0.1$ from the result for Prob. 293 and measure this distance in both directions along the perpendicular line. Repeat at every tenth for x from 0 to 1 and obtain the required airfoil graph.

MAXIMUM AND MINIMUM PROBLEMS

295. The total annual cost of a pipe line may be expressed as $C = Ad^2 + B/d^5$, where d is the diameter of the pipe, and A and B are positive and are substantially constants for a given range of diameter values. Determine the diameter for minimum cost.

296. (Taken from a physics text.) Given that

$$D = \sin^{-1}(u \sin r) + \sin^{-1}[u \sin(A - r)] - A,$$

where u and A are constants. Show that D is a minimum when $2r = A$.

297. It is shown in hydraulics that the quantity q of water (q cu. ft. per sec.) that flows over a certain type of spillway is given by

$$q = BD \sqrt{2g(H - D)},$$

where B is the width of the spillway, D is the depth of the water flowing over the spillway, g is the gravity constant, and H is the head of water.

Assuming that B and H are constants, determine the value of D that makes q a maximum.

298. Solve Prob. 92*d* by aid of calculus.

299. The equation $e = \tan \lambda \left(\frac{\cos \phi - f \tan \lambda}{\cos \phi \tan \lambda + f} \right)$ gives the efficiency e for a worm drive which has a lead angle λ , a pressure angle ϕ , and friction f .

a. Show that the given equation can be rewritten in the form

$$\frac{2f}{1 - e} = \cos \phi \sin 2\lambda + f + f \cos 2\lambda.$$

b. Show that the value of λ that makes the efficiency e a maximum is given by $\tan 2\lambda = \cos \phi / f$.

Note: The result in part (*a*) will facilitate the solution to part (*b*).

300. Let c = cost of one Mazda lamp plus installation charge in cents, b = cost of power for the lamp in cents per kilowatt-hour, V = actual operating voltage, V_0 = rated voltage for lamp, P_0 = watts input at voltage V_0 , F_0 = luminous output in lumens at voltage V_0 . The cost per lumen for 1,000 hr. (assuming 1,000 hr. of life on the rated voltage of the lamp) is

$$y = \left(\frac{c}{F_0} \right) \left(\frac{V}{V_0} \right)^{B_3 - B_2} + \left(\frac{bP_0}{F_0} \right) \left(\frac{V}{V_0} \right)^{B_3 - B_2},$$

where the B 's are constants that are determined experimentally.

a. Determine the value of $x = V/V_0$ that makes y a minimum.

b. For Mazda-C lamps from 60 to 150 watts: $B_2 = 3.613$; $B_3 = 1.523$; $B_5 = 13.50$. If $b = 6$ cents per kilowatt-hour, $P_0 = 100$ watts, and $c = 20$ cents, determine x_{\min} and hence determine the best value for the rated voltage V_0 if the operating voltage V is 120 volts.

301. An electric battery whose internal electromotive force is E_0 volts and whose internal resistance is r ohms has the terminal voltage $E = E_0 - Ir$ volts, the output power $P = E_0 I - I^2 r$, and the efficiency $\eta = P/(E_0 I)$ as functions of the current I amp. Sketch the graphs of E , P , and η each in terms of I in the range from open circuit ($I = 0$) to short circuit ($E = 0$). Determine by inspection the largest and smallest values of E , P , and η that occur at the end points of this range and whether any occur at intermediate points. Then differentiate to

determine the latter. Tabulate all such values together with the values of I at which they occur. (Notice that the "maximums" for E and I actually occur, while the "maximum" for η does not, since it arises as an indeterminate form.)

302. The power output of an electric generator is $E \cdot I$, where E is the constant terminal voltage and I the current. The power loss in the generator is the sum of a constant component P_0 and a variable component (due to heating loss) I^2R , R being the internal resistance of the generator. The efficiency of the generator may be written

$$\eta = \frac{\text{output}}{\text{input}} = \frac{\text{output}}{\text{output} + \text{losses}} = \frac{EI}{EI + P_0 + I^2R}$$

Determine the maximum value for the efficiency as the current I varies and express the result in terms of E , R , and P_0 . Also give the relation between the fixed and variable losses (P_0 and I^2R) when the efficiency is a maximum.

303. The relation between magnetic force F and air-gap separation s in an electromagnet is shown in Fig. 94. The magnetic force corresponding to an initial separation s_0 is counterbalanced by a constant applied force F_0 . If the armature A moves toward the core, work of an amount F_0s_0 is done on the load. (The excess of F over F_0 , when $s < s_0$, is not utilized.) It is desired to determine s_0 to obtain the greatest useful work.

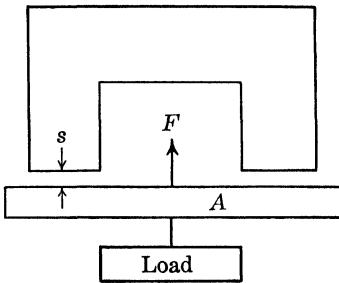

FIG. 93.

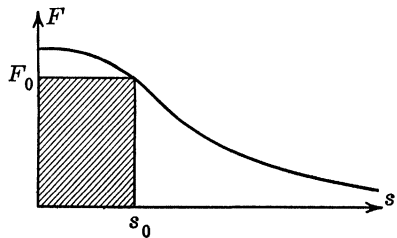

FIG. 94.

Solution: We have that $F \cdot s$ (the shaded area in Fig. 94) is to be a maximum (F is shown as a function of s in the graph). Hence (after differentiating), $0 = s(dF/ds) + F$, or

$$s = -\frac{F}{dF/ds}$$

Hence, show that the maximum value for F is located at a point whose abscissa is equal in length to the subtangent.

304. In a cylindrical cable (Fig. 95) in which the inner conductor has a radius r and the outer conductor has a radius R , the maximum

electric intensity in the insulation is

$$E_m = \frac{V}{r \log_e (R/r)}$$

and occurs at the surface of the inner conductor. Determine the value of r/R that makes $(E_m R/V)$ a maximum or minimum.

Remark: Electric breakdown occurs when the voltage V between conductors is large enough to make E_m larger than a particular value which depends on the kind of insulation.

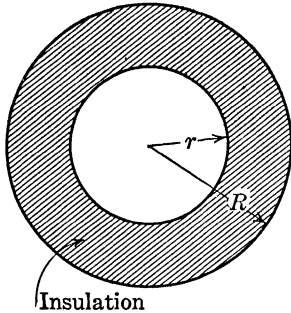

FIG. 95.

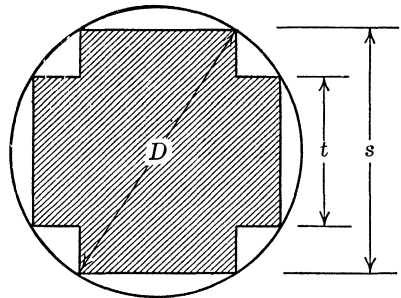

FIG. 96.

305. A solenoid has a fixed internal diameter of D in. and has a laminated core of the form shown in Fig. 96. Determine the dimensions s and t of the core so that the cross-sectional area of the core will be a maximum.

306. A source of light is to be placed directly over the center of a circular table of diameter 20 ft. The intensity of illumination at any point on the circumference of the table varies directly as the cosine of the angle between the vertical and the light ray, and inversely as the square of the distance of the point from the light. How high should the light be placed above the table to obtain the maximum intensity at the edge of the table?

307. One of the factors considered in choosing the size of wire for a transmission circuit is cost. The larger the cross-sectional area, the greater will be the first cost and hence also the annual charges for interest, taxes, and depreciation. At the same time the larger the cross-sectional area, the lower will be the cost of lost power since the heating losses will be lower. For bare wire the investment is directly proportional to the area, and the lost power is inversely proportional to the area; hence the total part of the line cost depending on wire size can be written as

$$C = k_1 a + \frac{k_2}{a},$$

where a is the area and k_1 and k_2 are positive constants.

Show that the area of the wire which makes C a minimum is that for which the two terms are equal, *i.e.*, that for which $k_1a = k_2/a$. Illustrate by sketching the two components and their sum, all on the same axes.

Remark: The basic law as stated in this problem is known as Kelvin's law.

308. Determine the value of $x = p_2/p_1$ that will make the expression $y = (p_2p_1)^{2/k} - (p_2/p_1)^{(k+1)/k}$, $k > 1$, a maximum and thus determine p_2 in terms of p_1 when y is a maximum.

Remark: This problem occurs in thermodynamics in the study of flow in a nozzle.

What is the value of the coefficient of p_1 in your result if $k = 1.4$?

309. A block that weighs 100 lb. rests on a horizontal surface for which the coefficient of friction is μ . A force of P lb. acts on the block as shown in Fig. 97, the action line of the force making an acute angle θ with the horizontal. The force just necessary to start this block in motion can be shown, by methods of physics and mechanics, to be

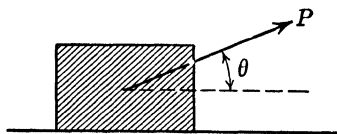

FIG. 97.

$$P = \frac{100\mu}{\cos \theta + \mu \sin \theta}$$

If $\mu = 0.2$, determine the largest and smallest values for P . Can you give a physical interpretation for each of your results?

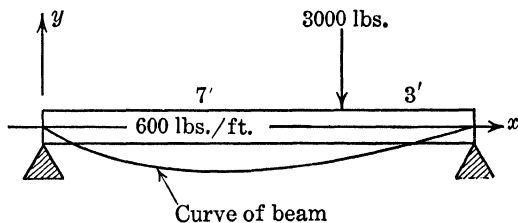

FIG. 98.

310. A beam is loaded with a concentrated load as shown in Fig. 98. The equation of the "curve of the beam" is given as follows:

For x from 0 to 7 ft.:

$$EIy = -25x^4 + 650x^3 - 38,650x,$$

For x from 7 to 10 ft.:

$$EIy = -25x^4 + 150x^3 + 10,500x^2 - 112,150x + 171,500,$$

where E and I are positive constants.

a. Determine the value of x that makes y a minimum, *i.e.*, makes the deflection a maximum.

b. Sketch on the same graph:

(1) y as a function of x from 0 to 10 ft.

(2) dy/dx as a function of x .

(3) M as a function of x if $M = EI(d^2y/dx^2)$.

(4) dM/dx as a function of x .

311. A beam $2L$ ft. long weighs w lb. per ft. and is supported at both ends and at the middle as shown in Fig. 99. The ordinate to the

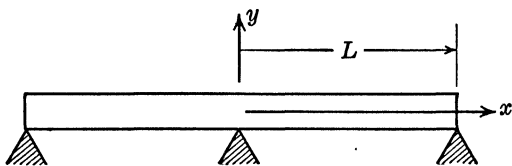

FIG. 99.

“curve of the beam” at x ft. to the right of the center support is given by

$$EIy = -\frac{wx^2}{48}(L-x)(3L-2x),$$

where E , I , and w are positive constants. The “curve of the beam” to the left of the support is the reflection of the given curve in the y axis through the middle support.

a. Determine the minimum value of y (maximum deflection of the beam).

b. Sketch the entire curve of the beam.

312. A weight of 100 lb. is to be raised by means of a lever which is uniform in cross section and which weighs 2 lb. per ft. of length. The force is to be applied at one end, the fulcrum is to be at the other end, and the weight of 100 lb. is to be at a distance of 1 ft. from the fulcrum. How long should the lever be to make the applied force smallest?

313. Let d denote the diameter of the wire from which a coil spring is made and let D denote the mean diameter of the coil. When the spring is compressed by an axial load P , the material in the spring experiences its greatest stress S at those points on the wire surface nearest the center line of the coil. S is given by the formula:

$$S = \frac{8PD}{\pi d^3} \left[\frac{\frac{4D}{d} - 1}{4 \left(\frac{D}{d} - 1 \right)} + \frac{0.615d}{D} \right]$$

For any given value of D , what value of d makes S the smallest?

***314.** The "moments of inertia" of an area A with respect to axes u and v inclined at an angle θ with the x and y axes are, respectively:

$$\begin{aligned} I_u &= I_x \cos^2 \theta + I_y \sin^2 \theta - P_{xy} \sin 2\theta, \\ I_v &= I_x \sin^2 \theta + I_y \cos^2 \theta + P_{xy} \sin 2\theta, \end{aligned}$$

and the "product of inertia of area" with respect to the u and v axes is given by

$$P_{uv} = \frac{1}{2}(I_x - I_y) \sin 2\theta + P_{xy} \cos 2\theta.$$

If I_x , I_y , and P_{xy} are constants,

a. Determine the angle θ that makes one of I_u , I_v a maximum and the other a minimum. Show test and compute the values of I_u and I_v . What is the value for P_{uv} for this critical angle θ ?

b. Determine the angle θ that makes P_{uv} a maximum or minimum and show that the value of $\tan 2\theta$ for such angles is the negative reciprocal of the values found in (a). What relation follows between the angles found in (a) and the angles that make P_{uv} a maximum or minimum?

315. The density s of water is given with sufficient accuracy by the equation $s = s_0(1 + at + bt^2 + ct^3)$, where s_0 is the density at 0°C . and t is temperature in degrees centigrade. If $a = 6.95(10^{-5})$, $b = -9.85(10^{-6})$, and $c = 15(10^{-7})$, estimate the temperature at which water has a maximum density.

316. The study of the formation of producer gas in chemical engineering leads to the equation

$$(b - a)v = x - x^{b/a},$$

where b and a are constants that depend on the process. x is the proportion of residual water remaining undecomposed and v is the corresponding value for the amount of CO_2 .

a. Determine a relation for the maximum value for v (amount of CO_2), assuming that b is larger than a .

b. If $a = 3.17$ and $b = 4.18$, determine the maximum value for v correct to slide-rule accuracy.

317. In a study of solid carbon reactivity it is found theoretically that the amount A of CO_2 present is given in terms of the time t (in seconds) by the equation

$$A = \frac{0.20k_1}{k_1 - k_2} (e^{-k_2 t} - e^{-k_1 t}),$$

where k_1 and k_2 are constants. Determine the maximum value for A and the time at which it occurs.

318. The total cost of manufacturing a certain article is fixed by:

1. The fixed organization cost which is \$90 per day.
2. The unit production cost of each article which is \$0.09.

3. The cost of repairs, maintenance, etc., which is $x^2/10,000$ per day (in dollars) as estimated by past records. x is the number of articles produced per day.

a. Show that the total cost for each article in dollars is

$$U = \frac{90}{x} + 0.09 + \frac{x}{10,000}.$$

b. Determine the number of articles to be produced each day to make the unit cost least.

VELOCITY AND ACCELERATION. RECTILINEAR MOTION

319. Figure 100 shows a crank arm OA , which revolves at the constant rate of ω radians per second and has a length of r ft. The connecting

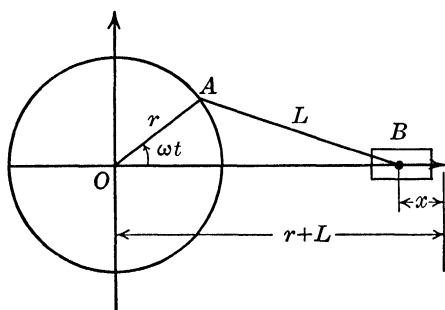

FIG. 100.

rod AB has a length of L ft. B is a piston which moves along the horizontal axis.

a. Show that $x = r(1 - \cos \omega t) + L - (L^2 - r^2 \sin^2 \omega t)^{1/2}$.

b. Expand the binomial to two terms by aid of the binomial theorem and obtain the approximate expression for x :

$$x = r(1 - \cos \omega t) + \left(\frac{r^2}{4L}\right) (1 - \cos 2\omega t).$$

c. Determine dx/dt and d^2x/dt^2 , using both the original and the approximate expressions for x .

d. Tabulate the values for dx/dt and d^2x/dt^2 from both results in (c) when $\omega t = 0, \pi/4, \pi/2, \pi,$ and $3\pi/2$. Assume that $r = 1$ ft., $L = 5$ ft., and $\omega = \frac{1}{2}$ radian per second.

e. When is the acceleration of the piston a maximum and hence what is the maximum inertia force which the piston can transmit? (The maximum inertia force is given by $F = ma$, where m is the mass of the piston and a is the maximum acceleration.) Use the approximate expression for d^2x/dt^2 to answer this question.

320. The mechanism shown in Fig. 101 is an air compressor. The displacement of the piston from its position when the crank arm AB is vertical is given by $x = r \cos \omega t$, where r is the length of the crank arm and the crank arm is rotating at ω radians per second.

a. If $r = 0.8$ ft. and $\omega = 4\pi$ radians per second, sketch the space-time, velocity-time, and acceleration-time graphs and label the amplitude and period of each.

b. If the weight of the piston and connecting rod is 100 lb., what is the force transmitted to the piston when $\omega t = \pi/6$? (Use force = mass \times acceleration; the mass = $10\frac{1}{32}$, approximately.)

c. What is the maximum inertia force which the piston can transmit to the crank arm and connecting rod?

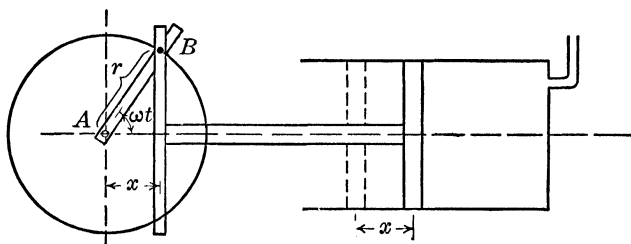

FIG. 101.

321. A 1-lb. weight is suspended from a spring fixed at the upper end and the spring stretches 0.375 in. The weight is pulled 0.1 ft. farther downward and then released with an initial velocity downward of 1.59 ft. per sec. Resistance to motion is always $\frac{1}{160}$ of the speed in feet per second. The displacement of the weight downward from its position of equilibrium is then given approximately by

$$y = e^{-0.1t}(0.1 \cos 32t + 0.05 \sin 32t).$$

a. Find the time t sec. at which the speed is largest and give the corresponding displacement.

b. Sketch a graph of the displacement as a function of time.

c. Let $t = t_1$ be a value of t that makes y a relative maximum. Let $t = t_2$ be the value of t that makes y a relative minimum and such that there are no other maximum or minimum values between t_1 and t_2 . Also suppose that t_2 is larger than t_1 . Determine an expression for y_2/y_1 , where y_2 corresponds to t_2 and y_1 to t_1 .

322. A streetcar oscillates harmonically in a vertical direction on its springs. The amplitude of motion is 1 in., its frequency is 2 cycles per second, the loaded cab weighs 20,000 lb., and the truck and wheels weigh 2,000 lb. Determine the force acting on the rails. Sketch.

Solution: Let y denote the displacement of the cab from its equilibrium position. Then

$$y = \frac{1}{2} \sin 4\pi t \text{ ft.},$$

$$\frac{d^2y}{dt^2} = - \left(\frac{4\pi^2}{3} \right) \sin 4\pi t \text{ ft. per sec. per sec.}$$

The force acting on the rails at any time t is the sum of the total weight of cab, truck, and wheels and the force required to produce the acceleration (which can be obtained by aid of Newton's second law of motion). Thus,

$$F = 22,000 - \left(\frac{20,000}{32.2} \right) \left(\frac{4\pi^2}{3} \right) \sin 4\pi t$$

$$= 22,000 - 8,180 \sin 4\pi t \text{ lb.}$$

VELOCITY AND ACCELERATION. CURVILINEAR MOTION

323. Determine the velocity and acceleration, in magnitude and direction, of the middle point of the connecting rod AB in Prob. 319 at the time $t = \frac{3}{4}$ sec. Use the data in Prob. 319*d*.

324. A point P moves along the parabola $y^2 = 36x$ according to the parametric equations $x = 4t^2$, $y = 12t$, where x and y are in feet and t is in seconds. Let the projections of P on the x and y axes be A and B , respectively.

a. Determine the velocities of A and B when $t = 2$ sec.

b. If, at the instant $t = 2$ sec., A is given (in addition to the motion due to P) a velocity equal in magnitude but opposite in direction to that of B , what will be the resultant velocity of A ? In mechanics this resultant velocity is called the "velocity of A relative to that of B ."

325. A weight moves around the curve

$$x = 5 \cos 10\pi t - \cos 50\pi t,$$

$$y = 5 \sin 10\pi t - \sin 50\pi t,$$

where x and y are in feet and t is in seconds.

a. Sketch the curve and determine the period of motion.

b. Determine the speed at any time t .

c. Determine the magnitude of the acceleration at any time t .

d. When is the magnitude of the acceleration a maximum or minimum and at what positions on the curve do these values occur?

***326.** The gear C has a diameter $2\overline{OF}$ of 16 in. and is fixed. \overline{OE} rotates about O at the rate of 12 r.p.m. Gear G is in mesh with gear C and has a diameter of 4 in. The connecting rod \overline{PB} , 50 in. long, is pivoted to gear G and P and causes piston B to move along the x axis.

a. Determine the parametric coordinates for P at any time t , assuming that P is at H at time $t = 0$.

- b. Determine \overline{OB} as a function of the time t .
 c. What is the velocity in magnitude of point P at time $t = 0$?
 d. What is the acceleration in magnitude and direction of point P at time $t = 0$?
 e. What are the values of the velocity and acceleration of B at time $t = 0$?

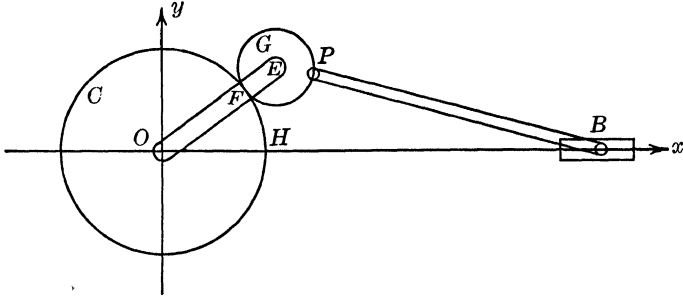

FIG. 102.

327. Same as Prob. 325 but for the curve

$$x = 3 \cos 10\pi t + \cos 30\pi t, \quad y = 3 \sin 10\pi t - \sin 30\pi t.$$

***328.** A wheel 4 ft. in diameter rolls without slipping on a horizontal straight track. The velocity of the center is constant and is 6 ft. per sec. directed toward the right. Write the parametric equations of motion, in terms of the time t sec., for a particular point on the rim of the wheel, measuring the horizontal distance or abscissa from a point at which this rim point would be on the ground. Then find the velocity and acceleration of this rim point at any time after it passes this reference point on the ground. Also determine the maximum numerical values of the velocity and acceleration.

***329.** A ladder is 8 ft. long and rests against a wall as shown in Fig. 103. It starts slipping in such a way that $d\theta/dt = -2$ radians per second and $d^2\theta/dt^2 = -3$ radians per second per second.

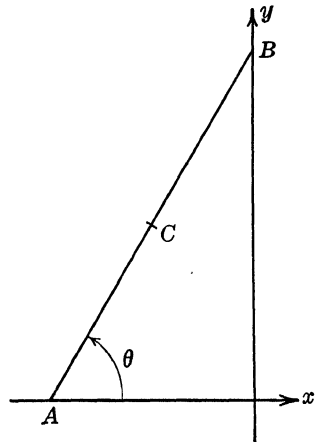

FIG. 103.

Determine the velocity and acceleration in magnitude and direction of the center of the ladder at the instant the ladder starts slipping (the

ladder makes an angle of 60° at the instant it starts slipping). Work this problem by two methods:

a. By aid of the parametric equations for the path of the mid-point.

b. By the use of a_t and a_n to obtain the acceleration, where a_t is the tangential component of the acceleration and a_n is the normal component.

***330.** A link mechanism is shown in Fig. 104. The member AD is fixed in a horizontal position. $AD = 1$ ft., $AB = DC = 2$ ft., $BC = 3.828$ ft. The members are free to turn at the pins A , B , C , and D . If member DC is rotating about D with a constant angular speed of 4 radians per second, find the velocities and accelerations of points C and B and the angular speed and acceleration of member AB , all at the instant that the member BC is parallel to the fixed

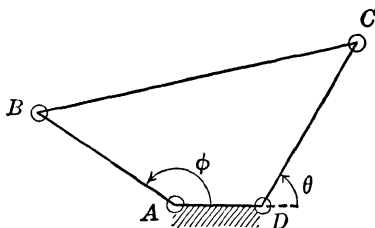

Fig. 104.

member AD , i.e., when $\theta = \pi/4$ and $\phi = 3\pi/4$.

***331.** Show that the most general equation of rectilinear motion which has constant acceleration is

$$s = a + bt + ct^2.$$

Identify the graph of s as a function of the time t and sketch the graph, if $a = 2$, $b = 1$, and $c = 1$.

Let (t_1, s_1) and (t_2, s_2) be two points on this space-time curve. Determine the average rate of change of s with respect to t as t increases from t_1 to t_2 and show, on your graph, the geometrical equivalent of this result.

Determine the average of the instantaneous rates of change of s with respect to t at t_1 and t_2 . Show that your result is the same as previously obtained.

What geometric property of the motion curve makes this true? Show, by means of an example, that the equivalence is not true in general if s is a polynomial in t of degree higher than two.

332. The Le Duc equation for the velocity v ft. per sec. of a projectile at a distance of x ft. in the bore of the gun is

$$v = \frac{ax}{b+x} = \frac{dx}{dt},$$

where a and b are empirical constants. Determine the distance x ft. where the total force imparting velocity to the projectile is a maximum. (Use force = mass \times acceleration.)

***333.** A circular disk in a horizontal position slides freely down a vertical wire. At the same time it rotates uniformly about its center at ω radians per second. Determine the magnitudes of the velocity and acceleration of a point of the disk r units from the center at the time t sec. Assume that the disk starts from rest.

334. A particle moves with simple harmonic motion in a groove in a horizontal bar and the bar falls freely. Find the magnitudes of the velocity and acceleration of the particle at the end of t sec. if the particle starts from the center of its path at the same time that the bar starts to fall. Assume that the particle makes a complete vibration in the groove in b sec. and that the amplitude of vibration is r .

335. At the instant a dive bomber releases a bomb the airplane makes an angle of 60° with the horizontal, the bomber is traveling at 500 miles per hour, and the airplane is approximately 2,000 ft. above the ground. Determine a first approximation for the parametric equations of motion of the bomb (neglect air resistance, wind, spiral motion of the projective, etc.). Also determine the point of impact on the earth, with respect to the position where the bomb was released.

DIFFERENTIALS

336. Bernoulli's equation from fluid mechanics may be written

$$p + \frac{\rho v^2}{2} = H,$$

where p is pressure, ρ is the constant density of the fluid, v is velocity, and H is a constant. Obtain an approximate formula for the change in pressure Δp due to a small change in velocity Δv .

337. The equation of the LL-3 scale on a 10-in. log log slide rule is

$$y \text{ in.} = 10 \log_{10} (\log_e x),$$

where the numbers that appear on the scale are values of x , and y is measured from the left-hand side of the rule. Use differentials to determine the approximate distance in inches (Δy) between the numbers marked $x = 3$ and $x = 3.2$.

Note: The true length is 25 cm.

338. van der Waals' equation for real gases is

$$\left(p + \frac{a}{v^2}\right)(v - b) = nRT,$$

where a , b , n , R are constants, p is pressure, v is volume, T temperature.

a. Determine an equation for dv if T is a constant.

b. Determine an equation for dv if p is constant.

339. A sphere is to be fired (baked) out of a certain kind of clay that has a linear shrinkage of 4 per cent. Determine the approximate

radius of the sphere before firing (baking) if the final radius is to be 6 in. Determine the approximate change in volume.

340. The heat Q required to raise the temperature T of a certain liquid 1°K . (one degree on the Kelvin or absolute centigrade scale) is given by $Q = a + bT + cT^2$. Determine an expression for the amount of heat necessary to heat the material from $T = 300.0^\circ\text{K}$. to $T = 300.1^\circ\text{K}$.

341. Determine the approximate change in $\tan \theta$ if θ increases from $45^\circ 10'$ to $45^\circ 11'$. Then check with your tables.

342. If $y = \sin x$ and x is to increase by 1 min., determine the value of x that makes the largest change in y . Then refer to your tables and check.

343. The force acting on a projectile from a gun after firing is $F = 4/(t + 0.05)^4$ lb. and is valid so long as the projectile is in the bore of the gun. The projectile weighs 5 lb. Use Newton's second law of motion ($F = ma$ where $m = \frac{5}{32}$ in this case and a is the acceleration) to find an approximate value for the speed 0.01 sec. after firing.

CURVATURE

344. The following statement is from "Resistance of Materials," by Seely: "The error made in approximating

$$R = \frac{(1 + (dy/dx)^2)^{3/2}}{d^2y/dx^2}$$

by $R = 1/(d^2y/dx^2)$ is never more than about 4 parts in 1,000 since the tangent of the angle to the elastic curve (the curve which a loaded beam assumes) is probably never larger than one part in twenty."

Assuming that the tangent to the elastic curve never has a slope (*i.e.*, dy/dx) numerically larger than 0.05, what is the largest percentage error possible in the value obtained for R by the preceding approximate formula?

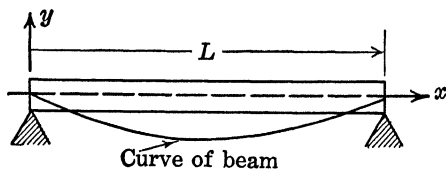

FIG. 105.

345. Figure 105 shows a simply supported beam loaded with a uniform load of w lb. per ft. The equation of the "elastic curve" (the curve of the beam) is

$$EIy = \frac{wLx^3}{12} - \frac{wx^4}{24} - \frac{wL^3x}{24},$$

where L is the length of the beam, I is a property of the cross section, and E is a property of the material from which the beam is made. E , I , and w are positive constants.

Determine the radius of curvature at $x = L/2$. Assume that $L = 12$ ft., $E = 288,000,000$ lb. per sq. ft., $w = 400$ lb. per ft., and $I = 0.008$ ft.⁴.

346. Determine the curvature and radius of curvature at $u = 0$, at $u = 0.5$, and at $u = 1$ to the railway easement curve which is given by the following parametric equations:

$$x = 600 \left(u - \frac{u^5}{10} \right) \text{ ft.},$$

$$y = 200 \left(u^3 - \frac{u^7}{14} \right) \text{ ft.}$$

347. Use the answer for Prob. 293 and determine the radius of curvature at $x = 0$, the leading edge of the airfoil.

INDETERMINATE FORMS

348. Figure 106 shows a flat plate in the form of an isosceles trapezoid. When this plate is subjected to an axial tensile load (pull) of P lb., the elongation of the plate is given by

$$\Delta = \frac{PL}{tE(c-a)} \log_e \frac{c}{a}$$

where E is a constant and depends on the material of the plate.

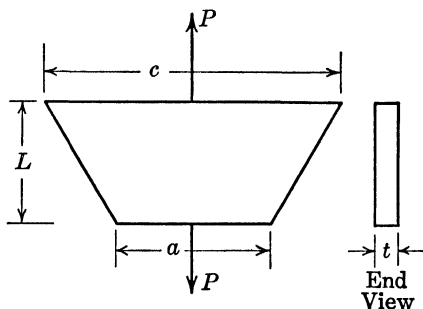

FIG. 106.

The formula for the elongation of a flat plate with a rectangular cross section is $\Delta = PL/AE$, where $A = a \cdot t =$ area with width a and thickness t .

Evaluate $\lim_{c \rightarrow a} \Delta$ in the first formula and obtain the second formula.

Remark: It is common engineering practice to check new formulas with formulas for simpler situations that are already known. This process of

checking often involves, as in the present problem, the evaluation of indeterminate forms.

349. A weight W lb. hangs by a spring whose spring constant is k lb. per ft. A harmonic force $F = P \sin \omega t$ lb. is applied to the weight. Let $p^2 = kg/W$, where $g = 32.2$ lb. per sec. per sec. and $q = Pg/W$. At the time t sec. the displacement of the weight from its equilibrium position is given by

$$y = \frac{q}{p^2 - \omega^2} (\sin \omega t - \sin pt) \text{ ft.}$$

This equation is valid provided that $p \neq \omega$.

Determine the limiting value of the displacement as p approaches the value ω (resonance case).

350. The current flowing in a series circuit, consisting of a resistance of R ohms and an inductance of L henrys connected to a battery of E volts, is given by

$$i = \left(\frac{E}{R} \right) (1 - e^{-Rt/L}).$$

Determine the limiting value for i as R approaches zero and thus obtain the equation for the current, i amp., that would flow in a purely inductive circuit.

351. Determine the limiting values for each of the antenna radiation patterns in Prob. 216 as θ approaches zero.

352. A "fluid foil" for a section of an airplane wing is given in parametric form as follows:

$$\begin{aligned} x_p &= x_s = (\sin \theta) \left[\frac{2}{\pi} (A - B) + B \right] + (\tan \theta) \left(1 - \frac{2}{\pi} \theta \right) (1 - A), \\ y_s &= (\cos \theta) \left[\frac{2}{\pi} (A - B) + B \right] - A \left(1 - \frac{2}{\pi} \theta \right), \\ y_p &= (\cos \theta) \left[\frac{2}{\pi} (A - B) - B \right] - (A - 2B) \left(1 - \frac{2}{\pi} \theta \right), \end{aligned}$$

where A and B are constants. x_s and y_s are parametric coordinates for the "suction" face of the wing section, and x_p and y_p for the "pressure" face.

Show that the two sets of parametric equations define the same result when $\theta = 0$ and when $\theta = 90^\circ = \pi/2$ and determine the results in terms of A and B .

353. In Prob. 398 the bar of equal strength is approximated by a bar having a large number of constant-section segments each of equal thickness. It is shown in elasticity that the area at the n th section is

$$A_n = \frac{P}{\sigma} \frac{1}{\left(1 - \frac{L\gamma}{m\sigma}\right)^n},$$

where m is the total number of segments and L is their combined length. Let $x = Ln/m$ and find the limiting value for A_n as n increases without limit. Note that m also increases without limit and that x/L is a constant for the limiting operation process.

354. The deflection of a clamped circular plate of radius a supporting a load P at its center is

$$w = \frac{P}{8\pi N} \left[r^2 \ln \frac{r}{a} + \frac{1}{2} (a^2 - r^2) \right],$$

where r is the radial or polar coordinate distance and N is the so-called "rigidity constant" for the plate.

a. Evaluate the deflection w , the slope dw/dr , and the "bending moment" $M = -N \left[\frac{d^2w}{dr^2} + \frac{1}{r} \frac{dw}{dr} \right]$ at the origin, *i.e.*, at $r = 0$.

b. Sketch the graph of the deflection as a function of r and find an inflection point.

c. Evaluate the bending moment M at $r = a$. This last result leads to the interesting fact that the bending moment at the edge of the plate is independent of the size of the plate.

Note: The deflection equation has another interpretation: w is also the deflection at the center of the plate caused by a load P at a distance r from the center.

355. The equation $W = \frac{p_2 V_2 - p_1 V_1}{1 - n}$ gives the work done by a gas as it expands from pressure p_1 and volume V_1 to pressure p_2 and volume V_2 . The constant n is used in the equation

$$p_1 V_1^n = p_2 V_2^n$$

and the given equation for work is valid if $n \neq 1$.

a. Show that the equation for work may be written in the form

$$W = p_1 V_1 \frac{(V_1/V_2)^{n-1} - 1}{1 - n}.$$

b. Use this last equation to determine $\lim_{n \rightarrow 1} W$ and thus obtain the formula that should be used when $p_1 V_1 = p_2 V_2$.

356. Use the data of the preceding problem and the equation

$$\frac{T_1}{T_2} = \left(\frac{V_2}{V_1} \right)^{n-1}$$

to determine

$$\lim_{n \rightarrow 1} \frac{wR(T_2 - T_1)}{1 - n},$$

and simplify your result by aid of the equation $pV = wRT$.

357. In Prob. 161 about the loud-speaker horn, start with the equation

$$y = [x(y_1^{1/n} - 1) + 1]^n,$$

notice that $y_1 > 1$, and determine the limit of y as n increases without limit through positive values and through negative values. Then sketch the horn outline for your resulting curve or curves.

RELATED RATES

358. If the quantity of wood in a tree is approximately proportional to the cube of the diameter at its base and if the diameter increases approximately 0.8 in. per year, what is the approximate rate of change in the volume? Give your result in terms of the constant of variation and the radius of the tree.

359. A given quantity of gas is expanding according to the adiabatic law: $pV^{1.4} = k = \text{constant}$. If the volume is 10 cu. in. when the pressure is 20 lb. per sq. in. and if the pressure is increased at the constant rate of 0.5 lb. per sq. in. per sec., what is the rate of change of the volume when the volume is 5 cu. in.?

360. The relation between altitude above sea level (h ft.) and the pressure (p lb. per sq. ft.) at a certain place on the earth and at a certain time of year is given by

$$p = 2,140e^{-0.000,035h}.$$

If an airplane is climbing at this particular spot on the earth and at the stated time at the rate of 200 miles per hour, what is the rate of change of the pressure due to change in altitude when the airplane is 3 miles up?

361. A boat is pulled in by means of a rope wound around a windlass on the dock which is 20 ft. above the deck of the boat. If the windlass is pulling the boat in at 10 ft. per sec., determine, when there is 100 ft. of rope out:

- The speed of the boat.
- The acceleration of the boat.

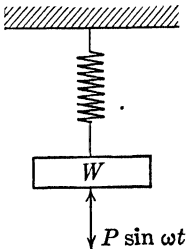

FIG. 107.

PARTIAL DIFFERENTIATION

362. Airy's stress function for the torsion (twisting) of a bar with an elliptical cross section with semimajor and semiminor axes a and b , respectively, is

$$\varphi = -\left(\frac{M}{\pi ab}\right)\left(\frac{x^2}{a^2} + \frac{y^2}{b^2} - 1\right),$$

where M is the "torque" or the amount of twist that is applied at the end of the bar.

a. Determine the value of φ for points (x, y) on the boundary of the ellipse.

b. Sketch a graph of the surface φ as a function of x and y . Show only that portion of the surface for points inside or on the boundary of the given ellipse.

c. Evaluate
$$\tau_{xz} = \frac{\delta\varphi}{\delta y}, \quad \tau_{yz} = -\frac{\delta\varphi}{\delta x}$$

and give their geometrical significance. These two quantities are measures of the "shearing stress" in the bar at any point of a cross section.

363. Given the function $F = (y - mx)(y + nx)(x - a)$, which is Airy's stress function for a beam with a triangular cross section.

a. Sketch a graph of the surface, F as a function of x and y . Assume that m , n , and a are all positive constants. Show only the portion of the surface whose projection on the xy plane is the triangle.

b. Evaluate
$$\sigma_x = \frac{\delta^2 F}{\delta y^2}, \quad \sigma_y = \frac{\delta^2 F}{\delta x^2}, \quad \tau_{xy} = -\frac{\delta^2 F}{\delta x \delta y},$$

which are measures of the tensile stress in the x and y directions and the shearing stress.

c. What are expressions for the curvature at a point on the surface in the x direction and in the y direction? What is the approximate relation between these results and those from (b)?

364. "Flow around a cylinder" may be characterized by the equation $\varphi = ax/(x^2 + y^2)$.

a. Determine the velocity components $v_x = \delta\varphi/\delta x$ and $v_y = \delta\varphi/\delta y$ and give the magnitude of the velocity that has these for components.

b. Determine the velocity in magnitude and direction at several points on the circle $x^2 + y^2 = 4$. Assume that $a = 1$.

Remark: This type of analysis sometimes appears in undergraduate texts on fluid mechanics.

365. The "stream function" and "velocity function" for a uniform translating flow past a circular cylinder are, respectively,

$$\begin{aligned}\psi &= -uy \left(1 - \frac{a^2}{x^2 + y^2}\right), \\ \varphi &= -ux \left(1 + \frac{a^2}{x^2 + y^2}\right).\end{aligned}$$

Show that $\frac{\delta\varphi}{\delta x} = \frac{\delta\psi}{\delta y}$ ($= v_x$), $\frac{\delta\varphi}{\delta y} = -\frac{\delta\psi}{\delta x}$ ($= v_y$), and give the expressions thus twice obtained for v_x and v_y , the velocity components.

366. Given the function

$$\psi = x^2 + xy - y^2 + x - y.$$

Show that $\frac{\delta^2\psi}{\delta x^2} + \frac{\delta^2\psi}{\delta y^2} = 0$. (Taken from a text in aeronautics.)

***367.** In thermodynamics, c_p is the specific heat at constant pressure and c_v is the specific heat at constant volume. For oxygen,

$$\begin{aligned} c_p &= 0.1904 + 0.000,056,5T - 0.000,000,009,81T^2, \\ c_v &= 0.1284 + 0.000,056,5T - 0.000,000,009,81T^2, \end{aligned}$$

where T is absolute temperature on the Fahrenheit scale and c_p and c_v are in B.t.u. per pound per degree Fahrenheit.

If $c_p = \left(\frac{\delta Q}{\delta V}\right)_P$ and $c_v = \left(\frac{\delta Q}{\delta P}\right)_V$, sketch the figures and compute the approximate change in Q .

a. If T increases from 400 to 402° at constant pressure.

b. If T increases from 400 to 402° at constant volume.

368. A rectangular box has a metal plate as its top. This plate has a hole in it of an elliptical shape with major and minor axes $2a$ and $2b$, respectively. A soap film is stretched across the hole and the pressure in the box is increased so that the soap film bulges upward. The ordinates to the soap film are given by

$$\varphi = k \left(1 - \frac{x^2}{a^2} - \frac{y^2}{b^2}\right),$$

provided that the pressure is not too large. k is a positive constant which depends on the values of a and b and the pressure.

a. Sketch a graph of this surface (soap film).

b. Determine the slope to this surface in

(1) The $\varphi - x$ plane at $x = a$.

(2) The $\varphi - y$ plane at $y = b$.

369. The equation for a perfect gas is $pV = kT$, where p is pressure, V is volume, T is temperature on an absolute basis, and k is a positive constant.

a. Determine $\delta T/\delta p$, $\delta T/\delta V$, and $\delta P/\delta V$.

b. Give an expression for the total differential dT , first in general terms by aid of partial derivatives and then in terms of p , V , k , dV , and dp .

***370.** The total heat Q in thermodynamics is a function of the temperature T , the pressure P , and the volume V . How many different

first partial derivatives are there of Q with respect to any one of these three variables? In answering this question, be careful to notice that $P \cdot V = RT$ where R is a positive constant. Then verify the following different equations for dQ , in which each equation involves two of these first partial derivatives:

$$dQ = \left(\frac{\delta Q}{\delta T}\right)_V dT + \left(\frac{\delta Q}{\delta V}\right)_T dV,$$

$$dQ = \left(\frac{\delta Q}{\delta T}\right)_P dT + \left(\frac{\delta Q}{\delta P}\right)_T dP,$$

$$dQ = \left(\frac{\delta Q}{\delta P}\right)_V dP + \left(\frac{\delta Q}{\delta V}\right)_P dV,$$

where the letter subscript denotes the quantity that is held constant. Thus, $(\delta Q/\delta T)_V$ indicates the first partial derivative of Q with respect to T with constant volume and the pressure was first eliminated by $PV = RT$.

***371.** Use the data in the preceding problem and express each of $(\delta Q/\delta V)_T$, $(\delta Q/\delta P)_T$, $(\delta Q/\delta P)_V$, and $(\delta Q/\delta V)_P$ in terms of P , V , R , $c_p = (\delta Q/\delta T)_P$, and $c_v = (\delta Q/\delta T)_V$. Notice, for example, that $(\delta Q/\delta P)_V = (\delta Q/\delta T)_V(\delta T/\delta P)_V$. Also, since

$$\frac{\delta Q}{\delta V} = \left(\frac{\delta Q}{\delta P}\right) \left(\frac{\delta P}{\delta V}\right) + \left(\frac{\delta Q}{\delta T}\right) \left(\frac{\delta T}{\delta V}\right),$$

it follows that $(\delta Q/\delta V)_T = (\delta Q/\delta P)_T(-RT/V^2) + (\delta Q/\delta T)_P(P/R)$.

372. Use the "contour graph" in Prob. 262 and determine approximate values for each of the following:

- (a) δi_b :- the plane $e_c = -1$ and at $e_b = 60$ volts.
- (b) the plane $e_b = 50$ and at $e_c = 0$.

PART V
INTEGRAL CALCULUS

CONSTANT OF INTEGRATION

373. The ram of a pile driver hits a pile and travels with it. The pile is driven 4 in. and moves that distance in 0.05 sec. Assuming the deceleration of the driver to be constant, determine the speed of the ram at the instant of impact.

374. The motorman of a streetcar increases the power of the motors by gradually cutting out resistance. The tractive effort on the rails increases steadily at the rate of 24 lb. per sec., the car weighs 16,100 lb., and the frictional resistance to motion is always 400 lb. Determine the distance (s ft.) that the car moves as a function of the time (t sec.) since the motorman started to increase the power, if the speed of the car at that instant was 10 ft. per sec.

Solution: By aid of Newton's second law of motion:

Total horizontal force = (mass)(acceleration in horizontal direction).
Hence

$$24t - 400 = \left(\frac{16,100}{32.2}\right) \left(\frac{d^2s}{dt^2}\right).$$

375. A ship, while being launched, slipped down the skids with a constant acceleration. If the ship slid the first foot in 10 sec. and if the skids were 400 ft. long, determine the time it took for the launching.

376. An automobile is moving along a straight road at 60 miles per hour when the driver decides to stop the car. If the brakes can slow the car down with a constant deceleration and if it takes 75 ft. to stop the car, what was the deceleration and how long did it take to stop the car?

377. The braking resistance of a streetcar is 200 lb. for each 1,000 lb. of weight. If a streetcar weighs 15,000 lb. and is traveling at 24 miles per hour, determine the time required to stop the car and the distance it will travel (in a horizontal direction). Use Newton's second law of motion to start the solution of the problem.

378. A 4-in. marine gun fires its shell weighing 38 lb. with a muzzle velocity $v_0 = 2,300$ ft. per sec. Actual trajectories of the shell are shown in Fig. 108.

1. For a gun elevation of 45° .
2. For a gun elevation of 75° .

- a. Determine the equations of the two theoretical trajectories neglecting air resistance, etc.
- b. Determine the theoretical altitude and range in both cases.
- c. What is the approximate error made in altitude and in range for both cases?

379. During an interval of 4 sec. after the current is shut off, the angular velocity ω of a certain electric motor is given with sufficient accuracy for engineering purposes by the equation

$$\omega = 200 - 20t + 0.5t^2$$

radians per second, where t is the time in seconds since the current is turned off.

- a. What is the angular acceleration at $t = 3$ sec.?
- b. How many revolutions does the motor make during the 4-sec. interval?
- c. Does the angular acceleration increase or decrease during this interval? Why?

380. A circuit (Fig. 109) consists of an inductance $L = 0.2$ henry connected to a generator with an electromotive force $e = 100 \sin \omega t$ volts ($\omega = 60$ cycles per second = 120π radians per second). The switch is to be closed at the time $t = 0$; hence when $t = 0$, the current $i = 0$ amp.

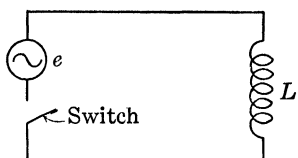

FIG. 109.

Given that $L(di/dt) = e = 100 \sin \omega t$, determine a formula for i in terms of the time t sec. Sketch the graph of i as a function of t for t from 0 to $\frac{1}{2}0$ sec.

Also determine the current flowing in the circuit when $t = \frac{1}{180}$ sec.

381. When a condenser (C farads) is charged from a battery (E volts) through an inductance (L henrys) and resistance (R ohms), the current is given by

$$i = \frac{E}{L \sqrt{\frac{1}{LC} - \frac{R^2}{4L^2}}} e^{-(Rt/2L)} \sin \left(t \sqrt{\frac{1}{LC} - \frac{R^2}{4L^2}} \right),$$

which, by the introduction of new symbols, may be written

$$i = \left(\frac{E}{Lg} \right) e^{-\alpha t} \sin gt.$$

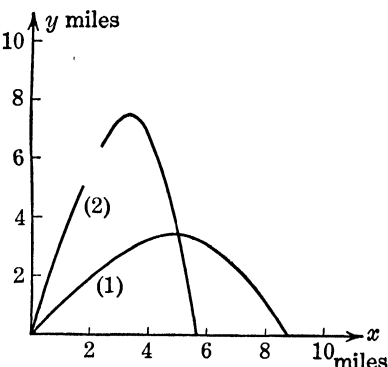

FIG. 108.

Integrate the expression for condenser voltage

$$e_c = \left(\frac{1}{C}\right) \int i dt$$

and obtain $e_c = -(Eg_0/g)e^{-\alpha t} \cos(gt - \eta) + k$. You are to obtain explicit expressions for g_0 and η .

Also determine k if $e_c = 0$ when $t = 0$.

382. A ship whose weight is 100 tons is traveling at the speed of 40 ft. per sec. when the power is cut off. The acceleration at any time t sec. later is given by

$$a = -\frac{1,600}{(t + 50)^2} \text{ ft. per sec. per sec.,}$$

and this is valid for about 5 min. Determine the velocity and distance traveled (assuming that the ship moves along a straight path) as functions of the time t sec. What are their values at the time $t = 4 \text{ min.}$?

383. A bomber is traveling horizontally at a height of h ft. with a speed of 300 miles per hour = 440 ft. per sec. Neglecting air resistance, etc., determine how far ahead of a target the bomb should be released if (a) $h = 10,000$ ft.; (b) $h = 20,000$ ft.; (c) $h = 30,000$ ft. Also compute for each case the angle that the bomb makes with the vertical on impact with a horizontal target. What is the theoretical speed of the bomb for each of these three cases just before impact?

The following table gives the *observed* striking speeds and angles of impact:

Altitude, feet	Striking speed, miles per hour	Angle of impact with vertical
2,000	540	50°
4,000	620	40°
6,000	690	34°
8,000	750	30°
10,000	790	26°
12,000	830	24°
15,000	870	21°
20,000	940	17°

384. Given that power = rate of change of work = dw/dt , that $w = mv^2/2$, and that $v = dx/dt$ = velocity. Derive the equation of motion of a body which is accelerated with a constant or uniform expenditure of power. Assume that $v = v_0$ and $x = 0$ when $t = 0$. m is the constant mass of the body and x is the rectilinear displacement.

Solution: Since $dw/dt = P = \text{power} = \text{constant}$, $w = Pt + c_1$.
When $t = 0$, $v = v_0$, and hence $c_1 = mv_0^2/2$.

Hence
$$Pt + \frac{mv_0^2}{2} = w = \frac{mv^2}{2},$$

or
$$v = \frac{dx}{dt} = \left(\frac{2Pt}{m} + v_0^2\right)^{1/2}.$$

Then
$$x = \left(\frac{m}{3P}\right) \left(\frac{2Pt}{m} + v_0^2\right)^{3/2} + c_2.$$

Since $x = 0$ when $t = 0$, determine $c_2 = -(m/3P)(v_0^3)$ and hence

$$x = \left(\frac{m}{3P}\right) \left(\frac{2Pt}{m} + v_0^2\right)^{3/2} - \left(\frac{m}{3P}\right) (v_0^3).$$

Now sketch a graph of x as a function of t . You will find it convenient for this purpose to sketch $3Px/mv_0^3$ as a function of $2Pt/mv_0^2$.

385. Given the equation $(mv)(dv/dx) = -mkx$, where m is a constant mass and k is a constant of variation. Integrate this equation and transpose all variable terms to the left-hand side. If kinetic energy (energy due to motion) is $mv^2/2$ and if potential energy (energy due to position) is $mkx^2/2$, what does your resulting equation state?

386. A beam of length L ft. is simply supported and is loaded with a concentrated load of P lb. at a point located $2L/3$ ft. from the left

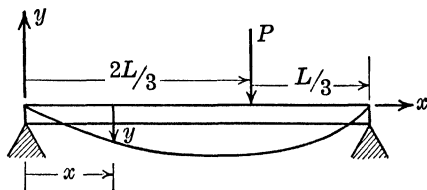

FIG. 110.

support. If axes are chosen as indicated in Fig. 110, the following equations hold:

For $0 < x < 2L/3$:

$$\frac{d^2y}{dx^2} = \left(\frac{P}{EI}\right) \left(\frac{x}{3}\right),$$

For $2L/3 < x < L$:

$$\frac{d^2y}{dx^2} = \left(\frac{P}{EI}\right) \left(\frac{2}{3}\right) (L - x),$$

where E and I are positive constants.

Determine the equation for the "curve of the beam," *i.e.*, for y as a function of x . Notice that at $x = 0$, $y = 0$; at $x = L$, $y = 0$; and at $x = 2L/3$ the curve is continuous and smooth, *i.e.*, the ordinates obtained from the two equations are the same and the slopes are likewise equal.

387. A simply supported beam is loaded with a load w in lb. per ft. that varies directly as the distance from the left support as indicated in Fig. 111. Given, from strength of materials, that

$$(EI) \left(\frac{d^4 y}{dx^4} \right) = -w = -100x,$$

where $E = 200,000,000$ lb. per sq. ft., $I = 0.00800$ ft.⁴, and y is the ordinate to the curve of the beam at abscissa x ft. from the left support

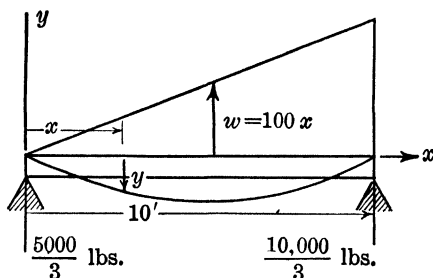

FIG. 111.

Given that $(d^3 y/dx^3)(EI) = 5,000/3$ when $x = 0$, $d^2 y/dx^2 = 0$ when $x = 0$, and $y = 0$ when $x = 0$ and when $x = L$. Determine the equation for y as a function of x , i.e., "the curve of the beam." Also determine the maximum deflection of the beam from a horizontal position.

388. Two weights of 7 lb. and 9 lb. hang on the ends of a string that passes over a smooth pulley. The smaller weight moves upward for 5 sec. at which instant the string breaks. How far will it continue to move upward after the string breaks? Use $g = 32$ ft. per sec. per sec. Notice that the velocity and acceleration of the smaller weight are always *numerically* equal but opposite in direction to those for the larger weight. Notice also that the total force acting on the smaller weight at any instant is equal to 7 lb. downward combined with the constant tension T lb. in the string.

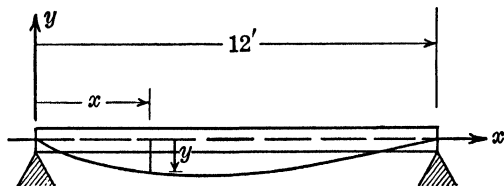

FIG. 112.

389. A wooden beam is 12 ft. long, 4 in. wide, and 8 in. deep, and is loaded with a uniform load of 400 lb. per ft. as shown in Fig. 112.

From strength of materials one can obtain the following equation:

$$\frac{d^2y}{dx^2} = 0.00204x - 0.000,170x^2,$$

where x and y are in feet.

Determine the equation for y in terms of x and also determine the minimum value of y , *i.e.*, the largest deflection of the beam.

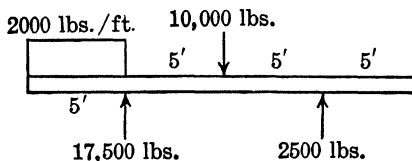

FIG. 113.

390. Figure 113 shows a beam supported at points 5 ft. from each end. The beam carries a uniformly distributed load of 2,000 lb. per ft. for the first 5 ft. and a concentrated load of 10,000 lb. at the mid-span.

Figure 114 shows a graph of the "shear" V as a function of x . The first integral of "shear" is "bending moment" M and, in this problem, the bending moment is zero when $x = 0$.

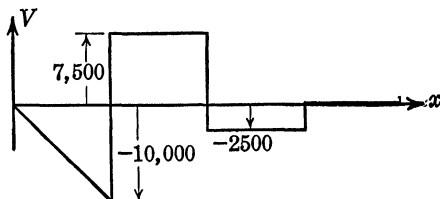

FIG. 114.

Sketch a graph of the bending moment M as a function of x without obtaining any equations. Make use of the following facts:

1. The derivative of the curve you are to sketch is the given "shear" curve.
2. The first integral of a horizontal line is an inclined straight line. The first integral of an inclined straight line is an arc of a parabola with axis vertical, and the position of the vertex of the parabola is determined by the abscissa where the straight line crosses the x axis.
3. The first integral represents the area between the "shear" curve and the x axis, from $x = 0$ to $x = x$.

391. Figure 115 shows the speed of a train t min. after it left the starting point.

a. Sketch the graph of distance as a function of time (t min.) without writing any equations. Make use of facts such as those stated in Prob. 390.

b. Obtain the equations for the distance from the starting point as a function of the time t min.

392. The velocity of a trimolecular reaction (discussed in physical chemistry) is given by

$$\frac{dx}{dt} = k(a - x)(b - x)(c - x),$$

where a , b , c , and k are constants. If $x = x_0$ when $t = 0$, determine an equation for t as a function of x .

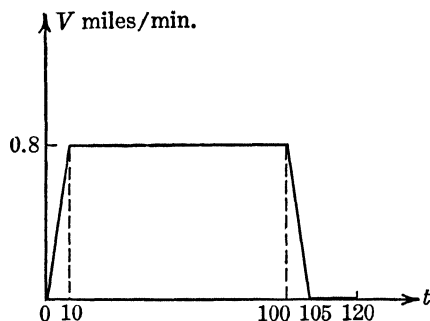

FIG. 115.

393. The speed of “inversion” of cane sugar is given by

$$\frac{dx}{dt} = 0.00154(10.023 - x),$$

where t is time in seconds and x is the amount in grams of the new type of sugar present at time t .

If $x = 0$ when $t = 0$, obtain an equation for x as a function of t and for t as a function of x . Sketch the graph for t as a function of x for t from 0 to 30 min. = 1,800 sec.

394. The decomposition of such materials as radioactive substances obeys the following law: The rate of decomposition at any moment is proportional to the quantity present at that moment. If one starts with an amount q and if at time $t = T$ the amount is $q/2$, obtain an expression for this special time, known as the period of half life.

395. Use the law stated in Prob. 394. If one-fourth of the material has decomposed in 2 hr., what is the value of the constant of proportionality and what is the period of half life?

396. A study of a corrosion-time relationship for iron requires the integration of $dy/dt = p/y$ where y is the thickness of the layer of corrosion at time t and p is a constant. Integrate if the material is clean at time $t = 0$.

397. Kick's law for the work done in reducing the size of a given amount of material (crushing rock, for example) assumes that the energy required for subdivision of a definite amount of material to be the same for the same fractional reduction in average size of the individual particles. Thus, if 10 hp.-hr. ($=E$) is required to crush a given amount of a certain material from 1 to $\frac{1}{2}$ in., average diameter, the energy required to reduce it from $\frac{1}{2}$ to $\frac{1}{4}$ in. or from $\frac{1}{4}$ to $\frac{1}{8}$ in. would be the same. Then $E = b \log (L_1/L_2)$ where L_1 is the initial and L_2 is the final average linear dimension and b is a positive constant to be determined experimentally. (It also depends on the base used for the logarithm.)

If $dE/dL = -C/L^n$,

a. Derive Kick's law. Use $n = 1$.

b. Derive Rittinger's law if $n = 2$: $E = C(L_1 - L_2)/L_1L_2$.

c. A general law. Assume that $n \neq 1$.

d. Determine the limiting value of the equation for E in (c) as n approaches the value one (an indeterminate form) and again derive Kick's law.

398. A bar of variable cross section is suspended from the upper end and supports a load P at its lower end (see Fig. 116). The total force on any section is the load P and the weight of the bar below this section. The most favorable condition exists when each section is equally stressed. This result follows from integrating

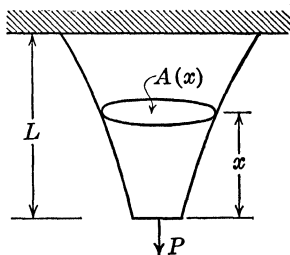

FIG. 116.

$$\frac{dA}{dx} = \frac{A\gamma}{\sigma},$$

where A is the area of the section of the bar at a distance x from the lower end, γ is the weight per unit volume of the bar, and σ is a constant allowable stress.

a. Find A if the area at $x = 0$ is $A = P/\sigma$.

b. Find the area at the fixed end $x = L = 12$ ft., if $P = 36,000$ lb., $\sigma = 16,000$ lb. per sq. in., and $\gamma = 450$ lb. per cu. ft.

399. A sled is being pulled along level ice by a rope, which is inclined at an angle of 11° with the horizontal. The force pulling the sled varies thus with the time: $F = 24t - 0.9t^2$ (F in pounds and t in seconds). The change in "momentum" of the sled is defined to be the product of the force component in the direction of motion multiplied by the time interval during which this constant force acts. Find the change in momentum of the sled during the interval from $t = 1$ sec. to $t = 5$ sec.

EVALUATION OF DEFINITE INTEGRALS

400. Evaluate the following definite integrals that were found in textbooks in chemical engineering and in technical journals for chemical engineering:

(a) $\int_0^1 y_n dw$ if $y_n = e^{ELw}(y_{n0} - Y_{n-1}) + Y_{n-1}$ and E, L, y_{n0} , and Y_{n-1} are constants.

(b) $A = 232 + \int_{176}^t (0.000,374t + 0.251) dt$.

(c) $V = \pi \int_0^y x^2 dy$ if $x dy = 2k dx$, where k is a constant and $x = a$ when $y = 0$.

(d) $\int_{w_0}^w \frac{dw}{gw^{2/3} + w^{5/3}}$.

(e) If $h(x) = 2.995e^{-14.627x} + 2.18e^{-82.22x} + 1.006e^{-212x}$, obtain an equation for $\theta(x)$ if

$$1 - \theta(x) = 4 \int_0^x h(x) dx.$$

(f) Evaluate $\int_0^{c_0} \frac{dc}{(62.6 - c)^2(C_e - c)}$, C_e is a constant.

401. An electric circuit contains in series an inductance of $L = 0.5$ henry and a resistance of $r = 20$ ohms. At the time $t = 0$ the current $i = 0.6$ amp. Given, from electrical engineering, that $L(di/dt) + ri = 0$ (for this problem), show that the current i at the time $t = 0.01$ sec. is given by the definite integral

$$\int_{0.6}^i \frac{di}{i} = -40 \int_0^{0.01} dt, \text{ and evaluate } i.$$

Also solve this problem by the constant of integration method.

402. In a circuit containing resistance and inductance in series, the power supplied to the magnetic field of the inductance is given by

$$P = \left(\frac{E^2}{R}\right) (e^{-Rt/L} - e^{-2Rt/L}).$$

Show that the total energy stored in the magnetic field, a quantity defined by $W = \int_0^\infty P dt$, has the value $W = LI^2/2$ where $I = E/R$.

403. If a battery of E volts and zero internal resistance is connected to a long uncharged submarine cable of capacitance C farads and resistance R ohms (each per mile), the battery current t sec. later is given by

$$i = E \left(\frac{C}{\pi Rt}\right)^{1/2} \text{ amp.}$$

a. Sketch a graph of i as a function of t . To show the general shape of this curve, sketch i/E as a function of $\pi Rt/C$.

b. Are the current i and the power $P = Ei$ undefined (momentarily infinite) when the battery is first connected?

c. Determine the charge $Q = \int_0^T i dt$ and the energy $W = \int_0^T P dt$ taken from the battery up to the time T sec. Are these ever undefined (infinite)? Sketch each as a function of T .

Remark: A mathematically "infinite" current is not physically possible, since no circuit can actually have zero resistance. However, the resistance can be so small that the momentary current is enormous compared with the normal current in the circuit and may be called "physically" infinite.

404. The potential energy (P.E.) stored in a beam is given by

$$\text{P.E.} = \frac{EI}{2} \int_0^L \left(\frac{d^2y}{dx^2}\right)^2 dx,$$

where E , I , and L are constants.

Determine the potential energy stored in a cantilever beam, which has for its equation

$$y = y_0 \left(1 - \cos \frac{\pi x}{2L}\right).$$

405. The force ejecting a projectile from a gun changes with the time after firing according to the equation

$$F = \frac{4.35}{(0.05 + t)^4} \text{ lb.} \quad (t \text{ in seconds}).$$

The total "momentum" given the projectile (momentum is defined as mass times velocity) during the 0.04 sec. required for the projectile to pass through the bore of the gun is obtained by evaluating the definite integral

$$\int_{t_1}^{t_2} F dt = \int_0^{0.04} \frac{4.35 dt}{(0.05 + t)^4}.$$

Evaluate this definite integral.

406. On a Mercator map of the earth, the distance on the map of a parallel of latitude from the equator is given by

$$S = \int_0^L R \sec \phi d\phi,$$

where S is in units corresponding to the unit on the map which represents 1 min. of longitude on the equator. Evaluate this integral for

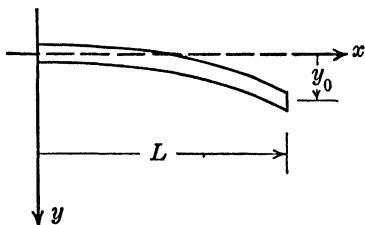

FIG. 117.

latitude $L = 60^\circ$ and $R = 10,800/\pi$ units. What is the corresponding distance on the earth itself?

407. The potential energy stored in a rod because of a torque (twist) which has been applied to one end (the other end of the rod being fixed) and which twisted the bar through an angle of 30° is given by

$$\text{P.E.} = \int_0^{30\pi/180} \left(\frac{200\varphi}{\pi} \right) d\varphi. \quad \text{Evaluate.}$$

408. Evaluate correctly to the nearest third decimal the following definite integral which appeared in a mechanics text:

$$\frac{1}{\pi} \int_0^\infty \frac{\alpha}{\alpha^3 + 1} d\alpha.$$

409. The two following empirical formulas were found for the "specific heat" at constant pressure for hydrogen:

$$c_p = 3.45 - 0.000,055,1T + 0.000,000,073,6T^2,$$

$$c_p = 2.86 + 0.000,028,7T + \frac{10}{\sqrt{T}}.$$

Compute $\int_{1,000}^{1,500} c_p dT$ for the two approximate formulas and thus determine the total heat required to raise the temperature of 1 lb. of hydrogen from 540 to 1040°F . (T = absolute temperature = degrees Fahrenheit plus 460 .)

410. Evaluate the following definite integrals that appeared in a text on aeronautics:

$$(a) \quad \int_{r_0}^r \left(\frac{R}{r^2} \right) \left(\frac{G^2}{4\pi^2 r^2} \right) dr,$$

where R , G , and r_0 are constants.

$$(b) \quad T = \left(\frac{R_8 V^2}{2} \right) \int_{-s/2}^{s/2} \sqrt{1 - \left(\frac{2x}{3} \right)^2} dx.$$

411. The general theory of arch dams (for example, dams built between the walls of a canyon) requires the solution of the equation

$$\int_{-t/2+c}^{t/2+c} \frac{h dh}{r_n + h} = 0$$

for r_n in terms of t and c . Show that $r_n = \frac{t}{\ln R - \ln(R-t)}$, where $R = t/2 + c + r_n$. When numerical values of R and t are given, this equation can be solved by approximate methods for r_n .

DEFINITE INTEGRALS. SIMPSON'S RULE AND TRAPEZOID RULE

412. In calculating the capacity of absorption towers in chemical engineering it is necessary to evaluate certain definite integrals by approximate methods. Evaluate the following definite integrals by use of Simpson's rule and the trapezoid rule using the given data (x_i is an empirical function of x , y_i is an empirical function of y):

$$\int_2^{12} \frac{dx}{x_i - x}, \quad \int_{0.010}^{0.026} \frac{dy}{y - y_i}, \quad \int_{0.010}^{0.026} \frac{(1 + y)(1 + y_i)}{y - y_i} dy.$$

x	x_i	$\frac{1}{x_i - x}$	y	y_i	$\frac{1}{y - y_i}$
2	5.10	0.322	0.010	0.0008	108
3	5.55	0.392	0.012	0.0040	125
4	6.13	0.469	0.014	0.0082	172
5	6.70	0.587	0.016	0.0122	263
6	7.40	0.715	0.018	0.0156	416
7	8.15	0.869	0.020	0.0183	588
8	9.05	0.952	0.022	0.0203	588
9	10.10	0.909	0.024	0.0220	500
10	11.40	0.715	0.026	0.0233	370
11	13.25	0.444			
12	16.00	0.250			

413. The length of an "indicator card" is 3.6 in. The widths of the diagram at intervals 0.3 in. apart are 0; 0.40; 0.52; 0.63; 0.72; 0.93; 0.99; 1.00; 1.00; 1.00; 1.00; 0.97; 0. Determine the area of the "indicator card" by Simpson's rule and the trapezoid rule and divide by the length of the card to obtain the "mean effective pressure." Work this problem using 6 subdivisions and 12 subdivisions and compare your results.

414. a. The table of data gives the "specific heat" s of water at temperature $\theta^\circ\text{C}$. Evaluate the definite integral $\int_0^{12} s d\theta$ and thus determine the total heat required to raise the temperature of 1 gram of water from 0 to 12°C .

θ	0	2	4	6	8	10	12
s	1.00664	1.00543	1.00435	1.00331	1.00233	1.00149	1.00078

b. Now evaluate the same definite integral assuming (the common assumption) that $s = 1$ calorie per degree centigrade for the given range.

c. How do your two results compare with the result obtained by assuming that $s = a + b\theta$, where the values of a and b are to be determined by the method of averages?

Remark: In engineering it frequently happens that one has the data and not the function required for the integration and hence that the use of Simpson's rule or the trapezoid rule is indicated (or the use of a planimeter).

415. Evaluate by an approximate method (you may evaluate the denominator by an exact method):

$$\frac{\int_0^{\pi/2} \sin \theta f(\theta) d\theta}{\int_0^{\pi/2} \sin \theta \cos \theta d\theta},$$

if

θ	0°	10°	20°	30°	40°	50°	60°	70°	80°	90°
$f(\theta)$	1.00	0.97	0.91	0.80	0.65	0.47	0.30	0.13	0.01	0.00

This problem occurs in a text on illumination.

416. Estimate the number of cubic yards of crushed rock necessary to make a roadbed of the dimensions shown in Fig. 118. The road

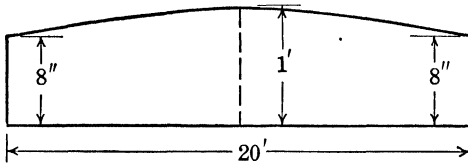

FIG. 118.

is to be 1 mile long. Assume that any other material added merely fills up the voids. Also assume that the crown of the pavement is an arc of a parabola.

417. The data for a "magnetization curve" (for an iron core inductance) are as follows in c.g.s. units:

H	0	8	10	15	20	30	40	60	80
B	0	13.0	14.0	15.4	16.3	17.2	17.8	18.5	18.8

where H is the number of gilberts per centimeter (a measure of the field intensity) and B is the number of kilolines per square centimeter (a measure of the flux intensity).

a. Plot a graph of B as a function of H .

b. Evaluate $w = (\frac{1}{4}\pi) \int_0^{18.8} H dB$,

(1) By use of the trapezoidal rule for each interval.

(2) By aid of Simpson's rule and about 10 subdivisions. Take the necessary data from your graph.

c. Plot $1/B$ as a function of $1/H$. The points will approximate a straight line. Hence $1/B = a + b/H$, approximately. Determine a and b by the method of averages and then substitute for H in terms of B in the definite integral and evaluate.

Remark: The value of this definite integral gives the energy stored in the magnetic field. The results by either method (a) or (b) are probably just as accurate as those by method (c) and are much more rapidly calculated.

418. In traveling by automobile a passenger checked the speedometer mileage by reading the rate of speed in miles per hour every 10 min. The readings were

Time	12:00	12:10	12:20	12:30	12:40	12:50	1:00
Speed	40	30	25	15	22	24	19

Estimate the distance traveled by the car in the 1 hr. Assume that the given ordinates belong to a continuous curve.

AREAS. AVERAGE ORDINATE

419. The voltage and current in an electric circuit are, respectively, given by

$$e = 160 \sin \omega t \text{ volts,} \quad i = 2 \sin \left(\omega t - \frac{\pi}{6} \right) \text{ amp.}$$

a. Determine the "average power," defined as

$$\left(\frac{1}{T} \right) \int_0^T ei dt,$$

where T is the period of both the voltage and current (T is to be determined).

b. Sketch the voltage and current waves from $t = 0$ to $t = 2\pi/\omega$. Sketch on the same graph the curve for "instantaneous power," defined by $p = e \cdot i$. Then show the graphical meaning of the preceding definite integral.

420. The voltage in an electric circuit is given by

$$e = E \sin \omega t \text{ volts,}$$

where E and ω are constants. You may assume, if you wish, that $\omega = 60$ cycles per second $= 120\pi$ radians per second.

a. Determine the average voltage for the interval of time from $t = 0$ to $t = \pi/\omega$. Also determine the average voltage from $t = 0$ to $t = 2\pi/\omega$.

b. Find the root-mean-square value of the voltage; *i.e.*, find the square root of the average value of the ordinate to the curve $y = E^2 \sin^2 \omega t$ from $t = 0$ to $t = 2\pi/\omega$.

c. Use your result from (b) to determine to three significant figures the value of E so that the root-mean-square value will be 120 volts.

d. Sketch graphs of $e = E \sin \omega t$ and $y = E^2 \sin^2 \omega t$, each for a complete period, and indicate the average ordinate for each curve for the complete period.

421. An alternating voltage is given by

$$e = 100 \sin 100\pi t + 50 \sin 300\pi t + 10 \sin 500 \pi t \text{ volts.}$$

a. Sketch a graph of the voltage wave for one complete period.

b. Determine the average value of the voltage from

(1) $t = 0$ to $t = 0.01$ sec.

(2) $t = 0$ to $t = 0.02$ sec.

c. Determine the root-mean-square value of the voltage over a complete period.

***422.** An alternating current is given by (k is an odd number)

$$i = I_1 \sin \omega t + I_3 \sin 3\omega t + \dots + I_k \sin k\omega t \text{ amp.}$$

Determine formulas for

a. The average value of the current from $t = 0$ to $t = \pi/\omega$ sec.

b. The root-mean-square value of the current from $t = 0$ to $t = 2\pi/\omega$ sec.

***423.** The voltage in the circuit discussed in Prob. 422 is given by

$$e = E_1 \sin \omega t + E_3 \sin 3\omega t + \dots + E_k \sin k\omega t \text{ volts.}$$

Determine the "average power" defined by

$$P = \left(\frac{1}{T}\right) \int_0^T ei \, dt,$$

where $T = 2\pi/\omega$.

Remark: Texts on alternating currents derive comparable formulas but use equations for the voltage and current that involve both sine and cosine terms.

424. The instantaneous rate of heat production of a current i amp. flowing in a constant resistance r ohms is i^2r watts. Determine the average rate of heat production over a cycle (one complete period) for the following periodic curves. Thus, determine the average ordinate to the curve $y = i^2r$ for a complete period.

- a. $i = I \sin 2\pi ft$, I is a constant.
- b. $i = I_1 \sin 2\pi ft + I_3 \sin 6\pi ft$, I_1 and I_3 are constants.
- c. $i = I_1 \sin \omega t + I_3 \sin (3\omega t - \theta)$, I_1 , I_3 , and θ are constants.

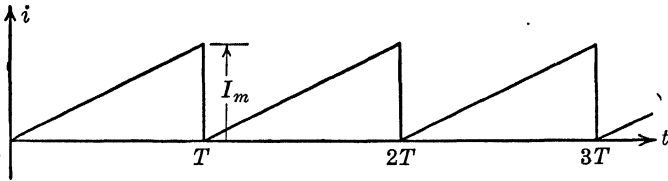

FIG. 119.

Portions of rectified sine waves (output of a controlled rectifier)

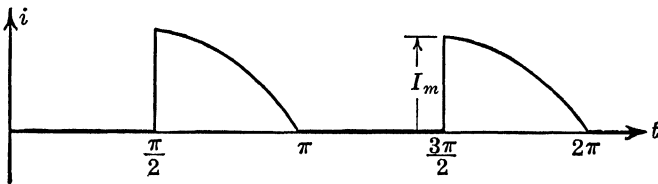

FIG. 120.

Remark: This heat production is the basis of the definition of the effective (root-mean-square) value of a periodically varying current. That is, $(I_{\text{effective}})^2(r)$ is the average rate of heat production over one cycle (one complete period).

425. A ball is thrown directly upward with an initial speed of 80 ft. per sec. If the y axis is positive upward measured from the ground and if the ball is thrown at time $t = 0$, show that $y = 80t - gt^2/2$ ft. ($g = 32$ ft. per sec. per sec., approximately).

a. Find the average value of the speed with respect to the time from $t = 0$ sec. to the time at which the ball is at its highest point.

b. Find the average distance with respect to the time for the same time interval as before.

426. Figure 121 shows a cantilever beam of length L ft. loaded with a concentrated load of P lb. at the free end. The equation of the "curve of the beam" with respect to the indicated axes is

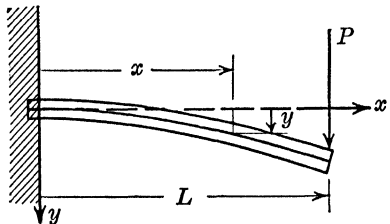

FIG. 121.

$$EIy = \left(\frac{P}{6}\right) (3Lx^2 - x^3),$$

where E and I are constants.

Figure 122 shows a similar cantilever beam of the same length and cross section but loaded with a uniform load of w lb. per ft. The equation of the curve of the beam in this case is

$$EIy = \left(\frac{w}{24}\right) (6L^2x^2 - 4Lx^3 + x^4),$$

where E and I are the same constants as before.

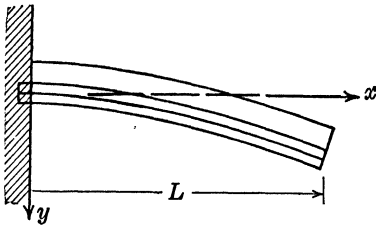

FIG. 122.

Suppose that the total load is the same in both cases so that $P = wL$ lb. Show that the *average ordinate* to the first curve for the span L ft. is equal to the largest ordinate (the ordinate at $x = L$) to the second curve. Hence show that for any cantilever beam the *mean deflection* produced by a vertical load applied at the free end is equal to the deflection

at the free end caused by the same load distributed uniformly over the length of the beam.

427. The velocity of flow of water out of a small circular hole on the side and at the bottom of a barrel is given by

$$v = c \sqrt{2gh},$$

where c is an empirical constant and h is the distance from the center of the hole to the top of the water.

Determine the "average head" h_{av} with respect to time and the "average velocity" v_{av} with respect to time as the head decreases from h_1 to h_2 . Assume that the cross-sectional area of the hole is A sq. ft. (A is small) and that the water is in a circular barrel of radius r ft.

Remark: The two terms h_{av} and v_{av} occur in chemical engineering and in fluid mechanics.

428. Use the data of the preceding problem to determine a formula for the time required to empty the circular tank if the water was originally at a height of h ft.

429. Taken from thermodynamics: If $c = \alpha + \beta T + \gamma T^2 =$ specific heat (α , β , and γ are constants), determine c_{mean} as temperature T increases from T_1 to T_2 .

430. In the equation for the flux density at any point in a torus: $B_x = 2NIu/x$ (u , N , and I are constants), why is it not accurate to find an average flux density by finding the flux density at $x = r_1$ and at $x = r_2$ and taking the mean?

What type of relation would have to hold between B_x and x for this procedure to be correct? Obtain a formula for the average flux density between $x = r_1$ and $x = r_2$.

431. If the particles in a ceramic clay are assumed spherical with diameters ranging from d to D , determine the mean volume and the diameter d_{av} that corresponds to this mean volume.

Use the results of this problem to determine d_{av} for a ceramic clay in which the diameters vary from 0.015 to 0.058 mm.

Remark: Notice that d_{av} is the value of the diameter that corresponds to the mean volume. The mean diameter would be a quite different value.

432. If the pressure and volume of a gas are related by the equation $pv^n = k$, where k and n are constants, determine expressions for the average value of pressure with respect to volume if $n = 1$ and if $n \neq 1$. (n is a positive quantity.) Assume that the volume increases from v_1 to v_2 .

What is the mean value of the pressure if $pv^{1.37} = 550$ and v increases from $v = 4$ to $v = 22$ cu. in. (p is in pounds per square inch)?

LENGTH OF ARC. AREAS OF SURFACES OF REVOLUTION

433. In engineering it is common practice to approximate the length of arc integral: $s = \int_{x_1}^{x_2} \sqrt{1 + (dy/dx)^2} dx$ by the integral

$$s_{\text{approx}} = \int_{x_1}^{x_2} [1 + (\frac{1}{2})(dy/dx)^2] dx$$

for curves whose slopes are small for the interval in question.

a. Expand the integrand in the first integral by the binomial theorem to three terms and write the resulting approximation for s . What must be true of $(dy/dx)^2$ for $x_1 \leq x \leq x_2$ to ensure that this series will converge?

b. Determine the percentage of error made by the use of the second integral for the length of the curve $y = x^2/100$ for x from 0 to 2 and for x from 0 to 50.

434. A piece of steel of length 10π in. is 5 in. wide and 0.1 in. thick. It is initially fastened in a horizontal position by clamping its ends and there is no initial stress in the steel. It is then deformed into a half sine wave with amplitude 1 in. (the ends remaining fixed). (A change in temperature could be the cause of the deformation.)

a. Determine the increase in the length of the steel strip by aid of the approximate length of arc formula

$$s = \int_{x_1}^{x_2} \left[1 + \frac{1}{2} \left(\frac{dy}{dx} \right)^2 \right] dx.$$

b. Determine the force that would be required to increase the length in a horizontal direction by the amount determined in (a). Use Hooke's law: $s/\epsilon = E = 30,000,000$ lb. per sq. in., where s is pull per square inch of cross-sectional area, E is Hooke's law constant or the modulus of elasticity, and ϵ is the *stretch per inch* of original length of the steel strip.

435. A steel spring is 1 in. wide, $\frac{1}{16}$ in. thick, and 10π in. long. It is fastened in a horizontal position and is then deformed into (a) a half sine wave with amplitude 1 in., (b) an arc of a parabola with ordinate at its vertex of 1 in., (c) an isosceles triangle with altitude 1 in. Determine the approximate increase in length for each case.

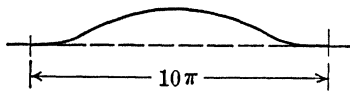

FIG. 123.

Remark: These are all approximations to the correct shape that the steel spring would assume. The shape that the spring would actually take would depend on the manner in which the loading was applied.

Figure 123 shows the more probable shape of the deformed spring.

436. A straight steel rail 100 ft. long increases in length by 0.2 ft. because of an increase in temperature. If the ends of the rail are fixed so that this increase in length must be taken care of by the bending of the rail, determine the maximum deflection of the rail from its straight position if the curved part takes the form of (a) an arc of a circle, (b) an arc of a parabola, (c) a half sine wave, (d) an isosceles triangle, (e) the curve $y = ax^2(x - 100)^2$ from $x = 0$ to $x = 100$.

Remark: The results of this problem give a good reason for leaving spaces between rails or sections of payment.

437. A corrugated piece of steel is 4 ft. wide and 10 ft. long. A section through the corrugation has the form of a sine wave with amplitude 0.2 in. and period 2 in. The steel is 0.05 in. thick. Determine the weight of the piece of steel if this steel weighs 477 lb. per cu. ft. What would be the weight of a flat piece of steel with the same length, width, and thickness?

438. An arched truss AB is 60 ft. long, weighs 20,000 lb., and is hinged at A . At B it rests on rollers as indicated in Fig. 124. The two curved parts ACB and ADB are parabolic with vertex at C and D , respectively. Determine the lengths of the curved parts of the truss, each correct to the nearest three significant figures. Why would it be *wrong* to use the *approximate length of arc formula* given in Prob. 434a?

***439.** Determine the elongation due to its own weight of a tapered vertical wire of length L ft., which is suspended from its top. At a distance y ft. from the top the change in length per unit length is $k(L - y)$ where k is a constant for the wire. It is assumed that the

change in length, although important in itself, can be neglected in comparison with L .

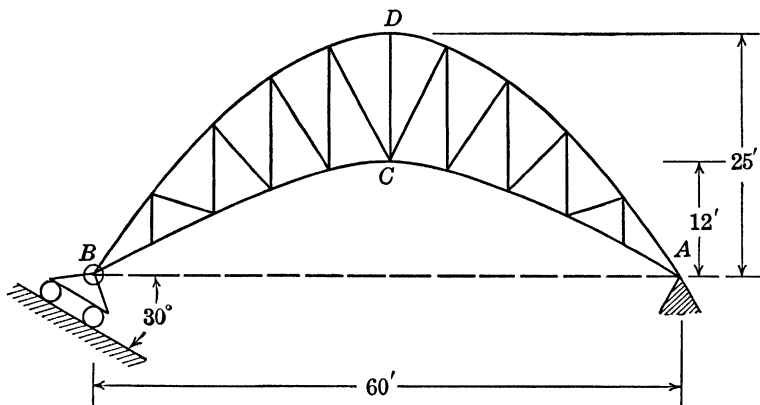

FIG. 124.

440. If a flexible cable is suspended from two points as shown in Fig. 125 and carries a load that is distributed uniformly in a horizontal direction, the curve assumed by the cable is a parabola. If the span is a and the sag f , show that the length of the cable is given by

$$L = 2 \int_0^{a/2} \sqrt{1 + \left(\frac{64f^2x^2}{a^4}\right)} dx.$$

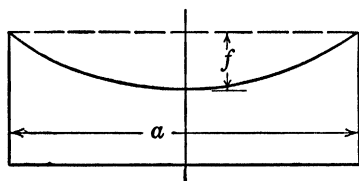

FIG. 125.

Also determine the length of a parabolic cable with span of 100 ft. and sag of 4 ft. Integrate by exact methods.

441. Work the numerical part of the preceding problem by expanding the integrand by the binomial theorem to three terms and integrating. What percentage of error is made if three terms are used; if just the first two terms are used?

442. The shape of an automobile headlight reflector is determined by a parabola revolved about its axis. If the reflector is 6 in. wide at the front end and is 6 in. deep, determine the area of the reflecting surface correct to the nearest third significant figure.

VOLUMES

443. A hemispherical bowl of diameter 6 ft. and full of water is rotated about its vertical axis at 30 r.p.m. The surface of the water assumes the shape of a paraboloid of revolution, and the equation of a cross section through the center and referred to axes through the vertex

of the parabola is $y = \omega^2 x^2 / 2g$, where ω is the angular speed in radians per second and g is approximately 32 ft. per sec. per sec. Determine the amount of water that overflows.

444. A right circular tank of diameter 4 ft. and height 5 ft. revolves about its geometrical axis at 10 r.p.m. If the tank was originally full of water, how much will spill out by the time the speed reaches the stated amount? Use the equation from Prob. 443.

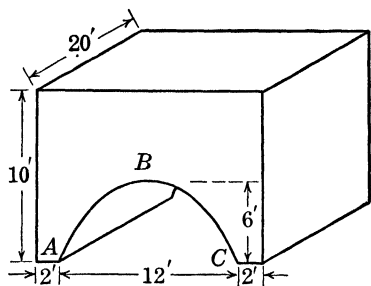

FIG. 126.

445. A concrete culvert is shown in Fig. 126. If the curve ABC is an arc of a parabola, find the number of cubic yards of concrete necessary for the culvert. Ignore shrinkage.

***446.** In chemical engineering use is made of "English saddles" in absorption towers. Several of these saddles were available, and it was desired to determine their total surface areas. Each of these saddles

seemed to have a common thickness (approximately) so that the total surface area could be approximated by doubling the "top" surface area.

In order to determine the surface area it was found that, at least to a good first approximation, these saddles were of the form

$$2az = x^2 - y^2.$$

The first step in the solution of the problem was to determine the surface area on the surface $2az = x^2 - y^2$, which is bounded by the four planes $x = b$, $x = -b$, $y = b$, and $y = -b$.

a. Show that the total (doubled) surface area is given by

$$S = \left(\frac{8}{a}\right) \int_0^b \int_0^b \sqrt{a^2 + x^2 + y^2} dy dx.$$

b. Sketch the volume represented by the preceding double integral, and then show that, in cylindrical coordinates, this volume is

$$\begin{aligned} S &= \left(\frac{16}{a}\right) \int_0^{\pi/4} \int_0^{b \sec \theta} \sqrt{a^2 + \rho^2} \rho d\rho d\theta \\ &= \left(\frac{16a^2}{3}\right) \int_0^{\pi/4} [(1 + c^2 \sec^2 \theta)^{3/2} - 1] d\theta, \end{aligned}$$

where $c = b/a$.

c. Assume that $c = 2$ and compute the approximate value of the preceding definite integral by the use of Simpson's rule. Use

$\Delta \theta = 7.5^\circ = \pi/24$ radians. Then tabulate the values of S for $2b = 0.25, 0.50, 1.00,$ and 1.50 in.

FIRST AND SECOND MOMENTS

447. A triangular corner whose area is 25 sq. in. is cut from a square 10 in. on a side. What are the dimensions of the triangle if the centroid of the remaining area is 4 in. from one side of the square?

448. a. Determine, in terms of R and r , the coordinates of the centroid of the area in the first quadrant as shown in Fig. 127.

b. Let r approach zero and obtain the coordinates of the centroid of a quarter circular area.

c. Let r approach R . What is the significance of your result?

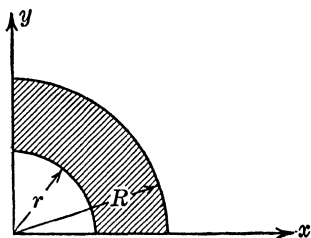

FIG. 127.

449. Determine the coordinates of the centroid of the two areas in Figs. 128 and 129.

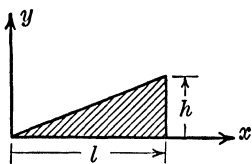

FIG. 128.

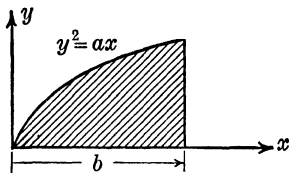

FIG. 129.

***450.** A simply supported beam has a length of L ft. and supports a load of w lb. per ft. as shown in the upper part of Fig. 130. The "equation of the curve of the beam" is

$$EIy = \frac{wLx^3}{12} - \frac{wx^4}{24} - \frac{wL^3x}{24},$$

where E and I are constants. From this equation one obtains

$$EI \left(\frac{d^2y}{dx^2} \right) = \frac{wLx}{2} - \frac{wx^2}{2}.$$

Let the left-hand member of this last equation be M and obtain

$$\frac{M}{EI} = \left(\frac{1}{EI} \right) \left(\frac{wLx}{2} - \frac{wx^2}{4} \right).$$

The graph of M/EI as a function of x is shown in the lower part of Fig. 130.

a. Show that the difference in slopes at any two points on the curve of the beam is equal numerically to the area under the curve in the M/EI diagram between the two points.

b. Show that the distance of any point A on the curve of the beam, measured normal or perpendicular to the original position of the beam, from a tangent drawn to the curve of the beam at any other point B ,

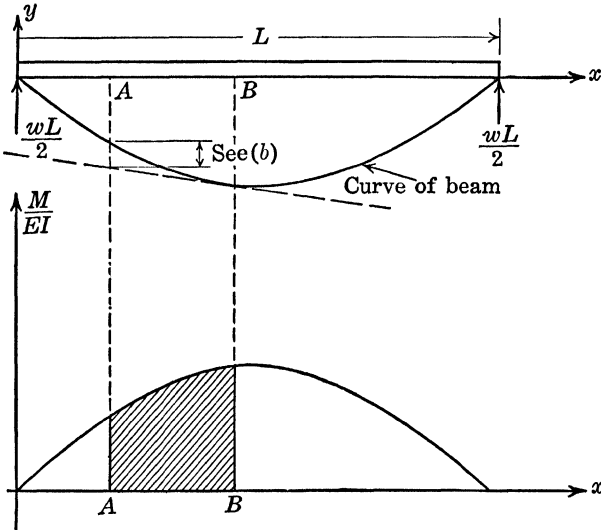

FIG. 130.

is equal numerically to the moment of the area under the M/EI curve between the two points and with respect to an ordinate through A .

Remark: The two statements in this problem form the basis in strength of materials for the *moment-area* or *slope-deflection* method of solving beams. So long as the loading on a beam is a combination of uniform and concentrated loading, the M/EI diagram will be made up of inclined straight lines and arcs of parabolas. The student can memorize the areas and centroids of such areas and so can use the two principles of this problem to determine the maximum deflection.

The basic method for solution of beam problems is the double-integration method.

c. If the point A is at $x = 0$ and the point B is at $x = L/2$ (the middle of the beam), determine the slope of the tangent to the curve of the beam at the origin and the deflection of the beam at the middle of the beam by aid of the statements in (a) and (b) and verify from the given equation for the curve of the beam.

451. *a.* What are the coordinates of the centroid of the area shown in Fig. 131? What are the radii of gyration of this area with respect to the x and y axes?

b. What would be a reasonable definition for the "third moment" of this same area with respect to the x axis? What would be the analogue of "radius of gyration" for third moment? Answer the same questions for the " n th moment." In particular show that the quantity which, when raised to the n th power and multiplied by the area of the rectangle to give the " n th moment" with respect to the x axis,

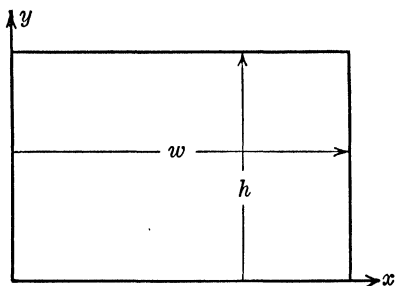

FIG. 131.

is $h/\sqrt[n]{n+1}$.

452. The "product of inertia" of an elementary area dA with respect to the x and y axes is defined by

$$dP = xy \, dA = xy \, dx \, dy.$$

Determine the "product of inertia" of the area in Prob. 451 with respect to the x and y axes.

*453. A particle moves along a straight line so that its acceleration is given by $d^2x/dt^2 = f(t)$, where $f(t)$ is a continuous function of t . When $t = 0$, $x = x_0$ and $dx/dt = v_0$. Show that the following equation gives the value of x at any time T :

$$x = x_0 + v_0 \cdot T + \int_0^T (T - t)f(t) \, dt.$$

Also show that the following equation gives the velocity at time T :

$$v = v_0 + \int_0^T f(t) \, dt.$$

Now show that the integral in the second equation is the area between the curve $y = f(t)$, the t axis, from $t = 0$ to $t = T$. Then show that the integral in the first equation gives the first moment of this area with respect to the line $t = T$.

454. Use the two formulas in Prob. 453 to determine at time $t = T$ the displacement of a particle if the acceleration is given as follows:

- (a) $\frac{d^2x}{dt^2} = +4$ ft. per sec. per sec.; when $t = 0$, $x = 0$, and $v = 0$.
- (b) $\frac{d^2x}{dt^2} = 4t$ ft. per sec. per sec.; when $t = 0$, $x = 0$, and $v = 0$.

$$(c) \frac{d^2x}{dt^2} = 1 + \frac{t}{2} \text{ ft. per sec. per sec.}; \quad \text{when } t = 0, x = 0, \text{ and } v = 0.$$

$$(d) \frac{d^2x}{dt^2} = 20t - t^2 \text{ ft. per sec. per sec.}; \quad \text{when } t = 0, x = 0, \text{ and } v = 0.$$

455. The kinetic energy of a rigid body rotating about an axis is given by $\text{K.E.} = J\omega^2/2$, where ω is the angular velocity in radians per second and J is the moment of inertia of the mass of the body with respect to the axis of rotation.

a. A homogeneous solid disk of radius R ft. and thickness L ft. weighs k lb. per cu. ft. and rotates about its geometrical axis with a constant angular speed of ω radians per second. Determine the kinetic energy.

b. A flanged wheel rotates with a constant angular speed of ω radians per second about its geometrical axis. The weights of the spokes and hub may be neglected and the total weight of the flange is the same as the weight of the solid disk wheel in (*a*). The width of the flange (in a direction perpendicular to the geometrical axis) is quite small. Determine the radius of the flange so that the kinetic energy will be the same as was obtained in (*a*) and give the significance of your result.

456. Given that the kinetic energy of a rigid body rotating about an axis is $\text{K.E.} = J\omega^2/2$, where ω is the angular speed in radians per second and J is the moment of inertia of the mass of the body with respect to the axis of rotation.

An elliptical disk with thickness $h = 0.2$ ft. and with an outline as given by the equation $9x^2 + 25y^2 = 2.25$ (x and y in feet) is homogeneous and weighs 100 lb. per cu. ft.

a. Show that the mass of the disk is $(\pi abh)(100)/32.2 = 0.293$ slug.

b. Determine the kinetic energy of the disk if it rotates about its geometrical axis with a constant angular speed of 20 radians per second.

c. What would be the result in (*a*) if the disk were circular with radius 0.4 ft.?

d. What would be the result in (*b*) if the elliptical disk revolved about an axis through one focus?

457. If a right circular disk revolves about its geometrical axis, then $T = J\alpha$, where J is the moment of inertia of the mass of the disk with respect to the axis of rotation, α is the angular acceleration, and T is the moment of the external force.

Figure 132 shows a homogeneous disk with radius 0.6 ft., thickness 0.2 ft., and weight 50 lb. per cu. ft. A weight of 50 lb. is hanging

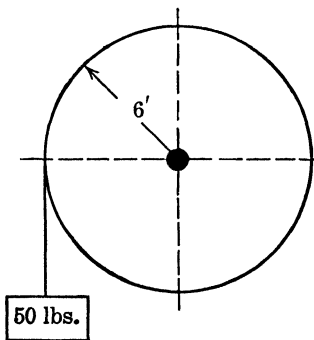

FIG. 132.

from a cord that passes around the disk as shown. At a particular instant the weight is allowed to fall. Determine the angular acceleration of the disk at the instant the weight starts falling. Neglect any axle effect and friction.

Solution: Substitute in $T = J\alpha$ and obtain

$$(0.6)(50) = (\alpha) \left[\frac{\pi(0.6)^4(0.2)(500)}{(2)(32.2)} \right].$$

458. Figure 134 shows a vertical section of a beam together with a side view (Fig. 133) of the beam from which this section was taken. Suppose that the unit stress (push) on the top fibers of the beam is s and on the fibers in the element dA is s_y . The graph shows the manner in which the unit stress s_y varies and from this graph it is seen that $s_y = sy/c$.

The total stress on the element dA is $s_y \cdot dA$ and the moment of this

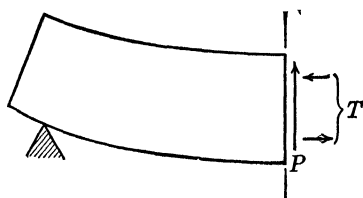
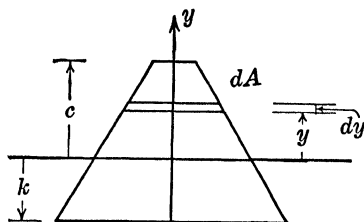

FIG. 133.

FIG. 134.

stress with respect to the x axis will be

$$dM = s_y \cdot y dA = \left(\frac{s}{c} \right) (y^2 dA).$$

Hence

$$M = \left(\frac{s}{c} \right) \int_k^c y^2 dA.$$

The integral is the second moment of the area of the cross section with respect to the x axis and hence $M = sI_x/c$.

Remark: This is a rough outline of a derivation to be found in texts on strength of materials. It illustrates how integrals for second moments or moments of inertia arise. Because of the frequency with which integrals for first and second moments arise in engineering derivations, it is convenient to use special names for them and to learn quick methods for their evaluation.

***459.** The following theorems are established in engineering courses and suggest how first and second moments will arise. Prove these theorems:

a. The total fluid force (sometimes miscalled the total fluid pressure) on one side of a vertical submerged area is equal to the weight of a cubic unit of the fluid multiplied by the area multiplied by the depth from the fluid level to the centroid of the area.

b. The total work done in pumping fluid from a horizontal pipe into a tank of any shape is equal to the weight of a cubic unit of the fluid multiplied by the volume of pumped fluid multiplied by the distance from the horizontal pipe to the centroid of the fluid in its final position.

460. Restate the two theorems of Pappus in *moment* language instead of in centroid language. These theorems are probably stated in your calculus text.

461. Figure 135 shows an airfoil approximation by aid of elliptical and parabolic arcs. If the parabolic arcs have their vertices on the

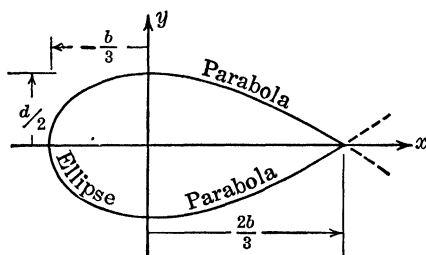

FIG. 135.

y axis, determine the moment of inertia of the enclosed area with respect to the x axis.

TOTAL FORCE

462. Determine the total gas force on the inside wall of a spherical shell if the pressure is 20 lb. per sq. in. and the inner radius of the shell is 2 ft.

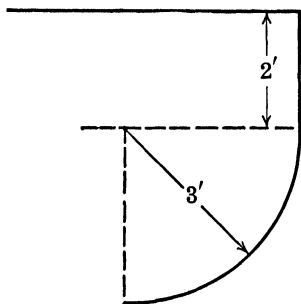

FIG. 136.

463. A sphere of diameter 5 ft. is immersed in water so that the water level is 2 ft. above the top of the sphere. Determine the total external force on the sphere. Start with the force on a zone of the sphere.

464. The vertical cross section of one side of a vessel filled with water is shown in Fig. 136. The length perpendicular to the plane of the figure is 4 ft.

a. Determine the total horizontal force on the side of the vessel shown. Show that this horizontal component is

the same as the total horizontal force on the side of a rectangular area of height 5 ft., width 4 ft., and top side at the water level.

b. Determine the total vertical component of the force.

c. Determine the total force in magnitude and direction.

WORK

465. A weight of 100 lb. is attached to a rope which weighs 2 lb. per ft. If 60 ft. of rope hang from the top of a building (with the weight at the end of the rope) and if the weight is raised a distance of 40 ft., determine the work done.

466. A derrick lifts a shovel of sand through a vertical distance of 30 ft. The sand in the shovel weighs originally 400 lb. and leaks out at a rate directly proportional to the square root of the distance traversed. If 320 lb. of sand reaches the top, find the work done.

467. A bead of weight w lb. slides without friction on the arc of a circle, which lies in a vertical plane. The radius of the arc is R ft. Starting with the expression for the work done by gravity as the bead moves from A to B (see Fig. 137),

$$W = \int_A^B w \cos \theta \, ds,$$

where ds is an element of length of the circular wire, and θ is the angle which the tangent to this arc makes with the vertical, show that W is equal to the product of the weight w and the vertical distance between the points A and B .

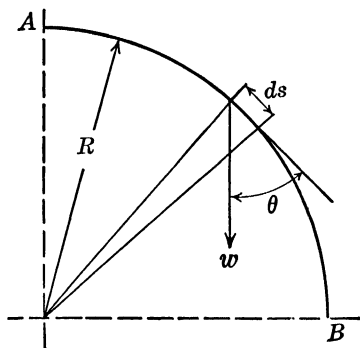

FIG. 137.

What would be your result if the points A and B were joined by a straight line? By an arc of a parabola with vertex at A ?

468. During a certain process in an engine, the pressure p lb. per sq. ft. changes with the volume (V cu. ft.) according to the law,

$$p = \left(\frac{3V^2}{5} + \frac{10}{V} \right) \quad (144).$$

Determine the work done by evaluating $W = \int_{V_1}^{V_2} p \, dV$ if the volume changes from $V_1 = 1$ cu. ft. to $V_2 = 3$ cu. ft.

469. If the pressure (p lb. per sq. ft.) changes with the volume (V cu. ft.) during a certain process in an engine according to the law $pV^n = C$, where C and n are constants, show that the work:

$$W = \int_{V_1}^{V_2} p \, dV$$

is given by the two following equations:

(a) $n \neq 1$:

$$W = \frac{p_2 V_2 - p_1 V_1}{1 - n},$$

(b) $n = 1$:

$$W = p_1 V_1 \ln \left(\frac{V_2}{V_1} \right).$$

Remark: The proofs of these two results are to be found in texts on thermodynamics and the resulting equations are fundamental in that study.

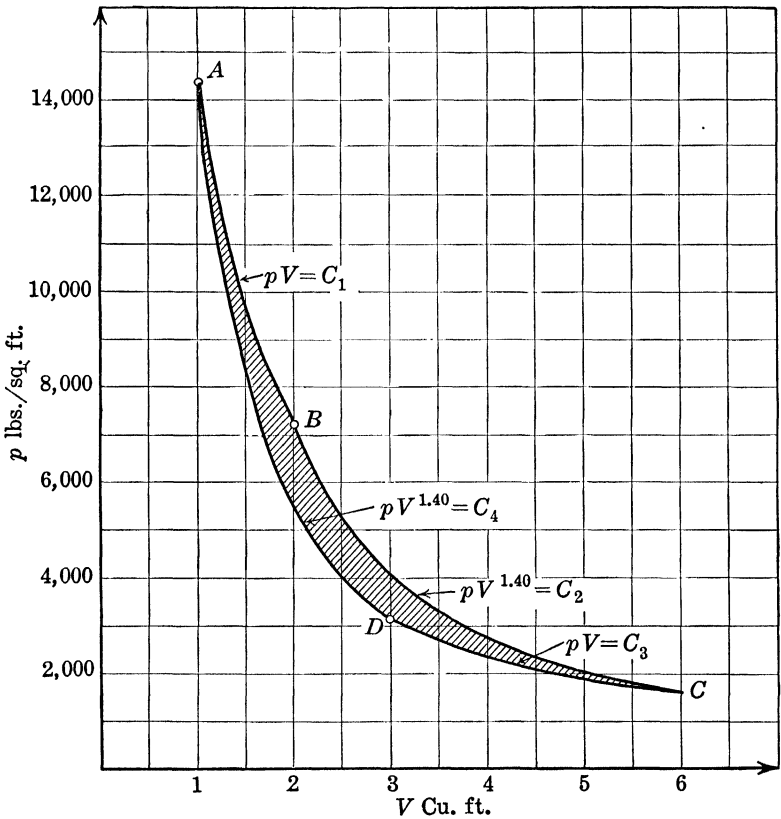

FIG. 138.

Data:

A. $V = 1$ cu. ft., $p = 14,400$ lb. per cu. ft., $C_1 = 14,400$.

B. $V = 2$ cu. ft., $p = 7,200$ lb. per cu. ft., $C_2 = 19,000$.

C. $V = 6$ cu. ft., $p = 1,545$ lb. per cu. ft., $C_3 = 9,270$.

D. $V = 3$ cu. ft., $p = 3,090$ lb. per cu. ft., $C_4 = 14,400$.

470. Figure 138 shows the relation between pressure and volume in a cylinder, as the piston completes a full cycle. Determine the net work done by finding the shaded area.

OTHER APPLICATIONS OF INTEGRAL CALCULUS

Remarks: The engineering student may be quite surprised at the few illustrative problems from engineering showing the uses of areas, volumes, surfaces of revolution, polar coordinate areas, etc. Aside from mathematical development, there are two important engineering reasons for studying these topics in calculus:

1. The use of these topics appears in centroids, moments of inertia, fluid force, work, etc.

2. The student is being taught the art of setting up definite integrals. The basic principle involved in each case is obtained from plane or solid geometry (area of rectangle or triangle, volume of disk or washer or thin shell, lateral surface area of a frustrum of a right circular cone, etc.). In junior or senior engineering courses the student will need to set up definite integrals for specific problems in which the fundamental principle will be more likely to be taken from physics or chemistry. These uses will be illustrated in the problems of this section.

It is of extreme importance that the engineering student learn to set up definite integrals directly from the figure by aid of some fundamental principle and not by memorizing definite-integral formulas.

471. Every text on fluid mechanics derives formulas for the amount of water that flows over various types of spillways and through various types of orifices. The basic principle used for that purpose is that

$$dq = c \sqrt{2gz} dA,$$

where q is the quantity of water in cubic feet per second, c is an empirical constant, and z is measured in feet from the water level to the elementary section dA . Verify the equations for q in the following orifice problems:

a. Rectangular orifice (Fig. 139):

$$q = \left(\frac{2c}{3}\right) \sqrt{2g} BH^{3/2}$$

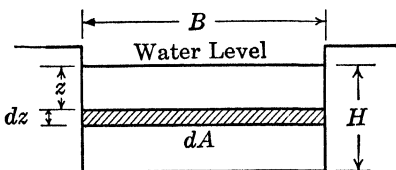

FIG. 139.

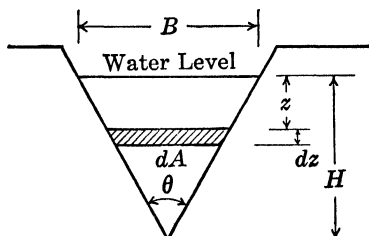

FIG. 140.

b. Triangular (isosceles) orifice (Fig. 140):

$$q = \left(\frac{8c}{15}\right) H^{3/2} \sqrt{2g} \tan\left(\frac{\theta}{2}\right).$$

c. Rectangular orifice (Fig. 141):

$$\begin{aligned} q &= \left(\frac{2cb}{3}\right) \sqrt{2g} (h_2^{3/2} - h_1^{3/2}) \\ &= (cbd) \sqrt{2g} \left(1 - \frac{d^2}{96h^3} - \frac{d^4}{2,048h^4} - \dots\right). \end{aligned}$$

where $h = \frac{h_1 + h_2}{2}$ and $d = h_2 - h_1$.

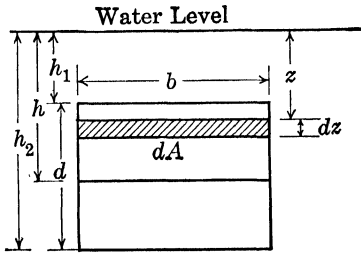

FIG. 141.

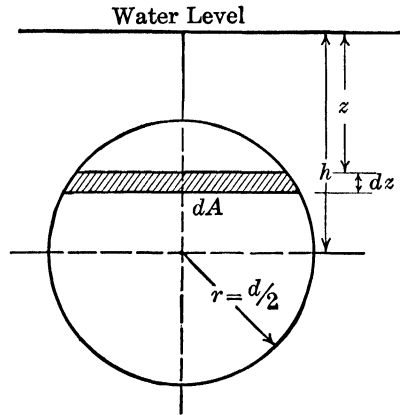

FIG. 142.

d. Circular orifice (Fig. 142):

$$q = (cA) \sqrt{2gh} \left(1 - \frac{d^2}{128h^2} - \frac{d^4}{16,384h^4} - \dots\right),$$

where $A =$ area of circle.

472. In mechanics one learns that the differential expression for the "frictional moment" dM_f is $dM_f = \mu\rho dN$, where dN is the normal pressure on the element dA (shown as a ring with radius ρ) and μ is the constant coefficient of friction.

A collar bearing is shown in Figs. 143 and 144 with radii r_1 and r_2 . The load W lb. is to be distributed over the area between the two circles of radii r_2 and r_1 and hence the pressure per unit area is

$$p = \frac{W}{\pi(r_2^2 - r_1^2)}.$$

Then the normal pressure on the ring element is $dN = p dA$. The

frictional moment will be given by

$$dM_f = (\mu\rho)(p)(2\pi\rho d\rho).$$

Integrate this from $\rho = r_1$ to $\rho = r_2$. Also determine the limiting values obtained by letting r_1 approach zero and by letting r_1 approach the value r_2 .

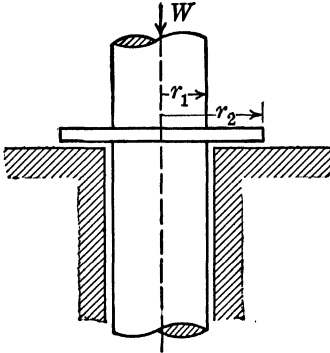

FIG. 143.

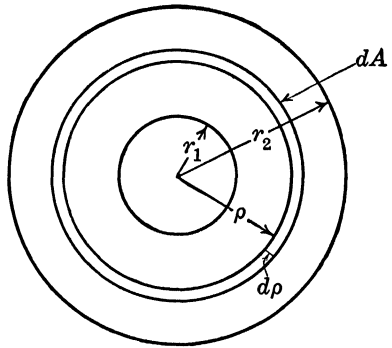

FIG. 144.

473. In thermodynamics the differential change in “entropy” is given by $dS = (cM/T) dT$, where M is the weight of the substance, c is its specific heat, and T is absolute temperature.

Determine the change in “entropy” for $M = 1$ (mol) of CO_2 in being heated at constant pressure from 40 to 340°F . ($T_1 = 40 + 460 = 500^\circ$ and $T_2 = 800^\circ$) if the specific heat for CO_2 at constant pressure is given by the empirical formula:

$$c = 7.15 + 0.0039T - 0.000,000,60T^2.$$

Also sketch or plot a graph showing an *area* that is equivalent in magnitude to the required result.

474. The temperature on the outside of a pipe (inner radius r and outer radius R) is T_o and on the inside is T_i (see Fig. 145). The application of Fourier’s heat law leads to

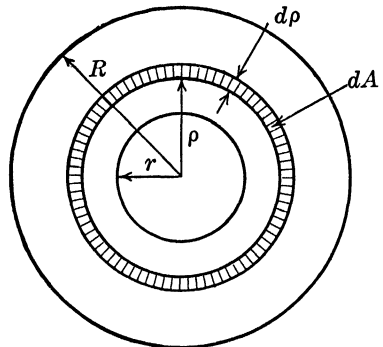

FIG. 145.

$$Q = -2\pi k\rho \left(\frac{dT}{d\rho} \right),$$

where k is a constant (the thermal conductivity), T is the temperature

on the elementary area dA , and Q is the amount of heat transferred per unit of time and is a constant.

Write this equation in the form $Q \int_r^R \frac{d\rho}{\rho} = -2\pi k \int_{T_i}^{T_0} dT$ and derive a formula for Q in terms of k , R , r , T_i , and T_0 .

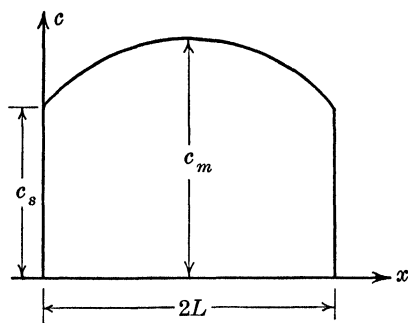

FIG. 146.

475. When drying conditions in a slab are such that the water diffuses to the surface before evaporating and when certain other conditions are assumed to be fulfilled, the moisture distribution curve in a cross section will be a parabola as shown in Fig. 146.

a. If c is the concentration at a distance x from one face, c_m the concentration at the middle, and c_s is the concentration at either face, and assuming that the thickness of the cross section is $2L$, show that

$$\frac{c_m - c}{c_m - c_s} = \frac{(x - L)^2}{L^2}$$

b. Evaluate $-dc/dx$ at $x = 0$ and $c = c_s$.

c. Since the "average concentration"

$$c_{av} = \frac{1}{L} \int_0^L c \, dx = \frac{1}{2L} \int_0^{2L} c \, dx,$$

show that $c_{av} = c_s + (2/3)(c_m - c_s)$,

(1) By integration.

(2) Directly from the figure by aid of Simpson's rule.

476. The current i_L amp. for an inductance coil of "self inductance"

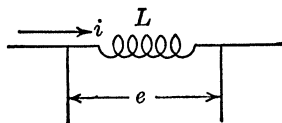

FIG. 147.

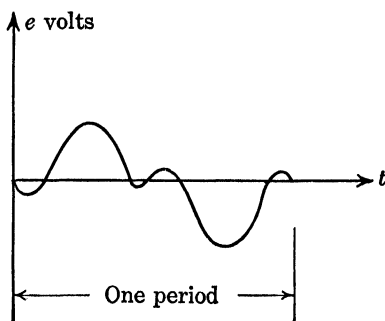

FIG. 148.

inductance" L henrys and negligible resistance is given in terms of the impressed voltage e volts by the equation $e = L(di_L/dt)$. If the wave form for the voltage e is that shown in Fig. 148, sketch the wave form for i_L .

Start the graph for i_L at any convenient height (assume $L = 1$ for the purpose of the sketch) and, after the graph has been completed, draw a horizontal axis midway through it, so that the resulting graph will represent a purely alternating current, *i.e.*, a current whose average value over a complete period is zero.

477. The magnetic field strength H on the axis of a circular conductor carrying a current I (Fig. 149) is

$$H = \frac{2\pi I a^2}{(a^2 + x^2)^{3/2}},$$

where a is the radius of the ring that carries the current and x is the distance of the point on the axis from the plane of the ring.

If the mechanical work done in moving a unit pole a distance dx along the axis of this conductor is $dW = H dx$, determine the work done in moving a unit pole from $x] = -\infty$ to $x = +\infty$.

478. Water is flowing along a horizontal circular pipe of radius a , and the speed of the water at a distance r from the center line of the pipe is $v = f(r)$, the units being feet and seconds. Set up an integral for the number of cubic feet of water discharged per second from the pipe.

Note: The number of cubic feet discharged per second by a stream flowing at any *given* speed is equal to the product of this speed and the cross-sectional area of the stream *flowing at this speed*.

479. a. Use the formula given in Prob. 254 and your result in Prob. 478 to determine the quantity of water discharged per second from that pipe.

b. What would the result in (a) become if the water had uniform speed?

480. From a theorem in elasticity it is known that the deflection expression in Prob. 354 gives not only the deflection at a distance r from the central point load on a circular clamped plate but also the deflection at the center for a load P at a distance r from the center of the plate.

Suppose that, instead of a concentrated load P at a distance r from the center, the load is uniformly distributed over a ring area element of width dr , inside radius r , and center at the origin. Then the deflection at the center is given by

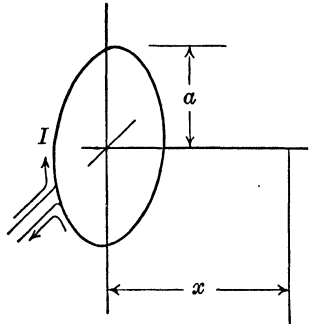

FIG. 149.

$$dw = \frac{2\pi br dr}{8\pi N} \left[r^2 \ln \frac{r}{a} + \frac{1}{2} (a^2 - r^2) \right],$$

where b is the load per unit area on the ring element.

Determine the deflection at the center due to a uniform load of b per unit of area on a circle with center at the center of the plate and radius c . What is the deflection if $c = a$?

481. In Prob. 480 suppose that the load P is uniformly distributed over a small circle of radius c whose center is at a distance c from the center of the plate. Evaluate the following integral, which gives the deflection at the center of the plate:

$$w = \frac{P}{4\pi^2 c^2 N} \int_0^{\pi/2} \int_0^{2c \cos \theta} \left[r^2 \ln \frac{r}{a} + \frac{1}{2} (a^2 - r^2) \right] r dr d\theta.$$

***482.** Figure 150 shows a top and side view of a 1-ft. section of a gravity dam. The dam will be supposed to be homogeneous and to

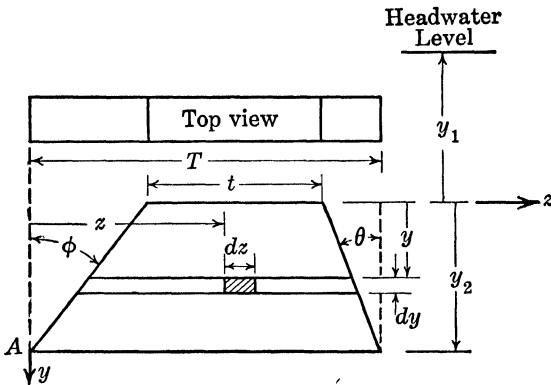

FIG. 150.

weigh w lb. per cu. ft. Show that

$$\begin{aligned} W_1 &= \text{total weight of dam} \\ &= \int_0^{y_2} \int_{y_2 \tan \phi - y \tan \phi}^{y_2 \tan \phi + t + y \tan \phi} w dz dy. \end{aligned}$$

The moment of this weight with respect to a line through the point A (perpendicular to the plane of this section) is

$$M_1 = \int_0^{y_2} \int_{Y_1}^{Y_2} wz dz dy,$$

where Y_2 and Y_1 are the limits previously used.

The water force acting horizontally in a downstream direction on the upstream (right-hand) face is

$$H = \int_0^{y_2} \bar{w}(y - y_1) dy$$

where \bar{w} is the weight of 1 cu. ft. of water. The moment of this horizontal force with respect to a line through A perpendicular to the side section is

$$M_2 = \int_0^{y_2} \bar{w}(y - y_1)(y_2 - y) dy.$$

The water force acting vertically on the upstream face is

$$W_2 = \int_0^{y_2} \bar{w}(y - y_1) \tan \theta dy$$

and the moment of this force with respect to the same perpendicular line through A is

$$M_2' = \int_0^{y_2} \bar{w}(y - y_1)(\tan \theta)(y_2 \tan \varphi + t + y \tan \theta) dy.$$

The student should study the figure and the relation to these definite integrals.

Show that these integrals evaluate to the following results:

$$W_1 = \frac{wy_2(T + t)}{2}; \quad H = \bar{w}y_2\left(\frac{y_2}{2} - y_1\right);$$

$$M_2 = \left(\frac{\bar{w}y_2^2}{2}\right)\left(\frac{y_2}{3} - y_1\right), \text{ etc.}$$

INFINITE SERIES

483. Problem 440 concerns a parabolic cable whose length was found to be

$$L = 2 \int_0^{a/2} \sqrt{1 + \left(\frac{64f^2x^2}{a^4}\right)} dx.$$

a. Expand the integrand by the binomial theorem and integrate.

b. Observe that the resulting series for L is an alternating series. What is an error term if the first two terms are used to compute L ?

c. Show that the series converges if $|f/a| < \frac{1}{4}$.

Remark: Although this question of convergence can be answered by testing for the interval of convergence of the series in (a), a simpler method is to notice that the series for the integrand will converge if $64f^2x^2/a^4 < 1$. The largest value that x^2 can have is $a^2/4$ and hence the integrand series will converge for all values of x in the interval from 0 to $a/2$ if

$$\left(\frac{64f^2}{a^4}\right)\left(\frac{a^2}{4}\right) = \frac{16f^2}{a^2} < 1.$$

The theorem about the interval of convergence on integration of a power series is needed to complete the solution.

484. Expand the integrand of the length of arc formula:

$$L = \int_{x_1}^{x_2} \sqrt{1 + \left(\frac{dy}{dx}\right)^2} dx$$

by the binomial theorem. Show that the resulting series is an alternating series. Assuming that $|dy/dx| < 1$ for the required values of x , determine an error formula for the error made by using only the first two terms of the series. Does the requirement that $|dy/dx| < 1$ for $x_1 \leq x \leq x_2$ ensure that the series will converge?

485. The two following definite integrals arise in fluid mechanics derivations. Expand the integrands into power series and show that the given series are correct.

$$\begin{aligned} (a) \quad Q &= 2 \int_{-r}^r \sqrt{2g(E-z)} \sqrt{r^2-z^2} dz \\ &= \pi r^2 (2gE)^{1/2} \left(1 - \frac{r^2}{32E^2} - \frac{5r^4}{1,024E^4} - \cdots \right). \end{aligned}$$

$$\begin{aligned} (b) \quad Q &= B \int_{-z_0/2}^{z_0/2} \sqrt{2g(E-z)} dz \\ &= Bz_0 \sqrt{2gE} \left(1 - \frac{z_0^2}{96E^2} - \cdots \right). \end{aligned}$$

486. In a series circuit containing resistance R ohms, inductance L henrys, and a d.c. voltage E volts, the current i amp. is given in terms of the time t sec. by

$$i = \left(\frac{E}{R}\right) (1 - e^{-Rt/L}).$$

Show that

$$i = \left(\frac{Et}{L}\right) \left(1 - \frac{Rt}{2L} + \frac{R^2 t^2}{6L^2} - \cdots \right).$$

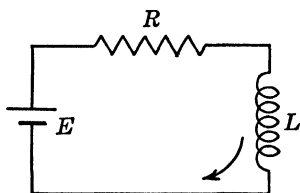

FIG. 151.

For what values of Rt/L does this series converge? What is an error formula if the first two terms are used? If the first three terms are used?

Let $x = Rt/L$ and $y = Ri/E$. Plot a graph of y as a function of x : (a) using the exact equation and (b) using the first three terms of the series.

487. The time t sec. required for a certain pendulum of length L ft. to swing from its lowest point through an angle θ is given by

$$t = \sqrt{\frac{L}{g}} \int_0^\varphi \frac{dz}{\sqrt{1 - \sin^2(A/2) \sin^2 z}}.$$

where $g = 32.2$ ft. per sec. per sec, A is the greatest angle reached in the swing, and $\sin \varphi = \frac{\sin (\theta/2)}{\sin (A/2)}$. If $L = 2$ ft., $A = 60^\circ$, find t for $\theta = 30^\circ$.

488. The chance, in throwing 100 coins, of throwing exactly 50 heads and 50 tails is given by $\frac{100!}{(50!)^2(2^{100})}$. The value of this quantity is very closely given by

$$P = \frac{2}{\sqrt{2\pi}} \int_0^{0.1} e^{-x^2/2} dx.$$

Evaluate P , correct to three significant figures.

Remark: Books on mathematics of statistics will explain how this definite integral was obtained.

489. Show that the area bounded by the curve $y = x^n$ and the x axis, from $x = x_1$ to $x = x_2$ (both x_1 and x_2 are positive), is

$$A = \frac{x_2^{n+1} - x_1^{n+1}}{n + 1}, \quad \text{if } n \neq -1,$$

$$A = \ln \left(\frac{x_2}{x_1} \right), \quad \text{if } n = -1.$$

If n is close to -1 in value, the computation of the area by the first equation is likely to be inaccurate if ordinary tables are used.

Obtain a series for calculating the value of A when n is close to -1 .

$$\begin{aligned} \text{Solution: } A &= (x_1^{n+1}) \frac{(x_2/x_1)^{n+1} - 1}{n + 1} \\ &= (x_1^{n+1}) \left(\ln \frac{x_2}{x_1} \right) \left(1 + \frac{n + 1}{2!} \ln \frac{x_2}{x_1} + \dots \right), \end{aligned}$$

since $(x_2/x_1)^{n+1} = e^{(n+1)\ln(x_2/x_1)}$ and $e^z = 1 + z + z^2/2! + \dots$.

Use this series result and also the original formula to calculate the value of A if $x_1 = 2$, $x_2 = 5$, and $n = -0.99$.

490. The rate p_r at which a black body radiates heat is found by integrating

$$p_r = \int_0^\infty \frac{c_1 dx}{x^5(e^{c_2/Tx} - 1)},$$

where c_2 and c_1 are positive constants and T is absolute temperature and is constant for this problem. Make the substitution

$$z = \frac{c_2}{Tx}$$

and obtain

$$p_r = \left(\frac{c_1 T^4}{c_2^4} \right) \int_0^\infty \frac{z^3 e^z dz}{1 - e^z}.$$

Expand $e^z/(1 - e^z) = e^z + e^{2z} + e^{3z} + \dots$, substitute in the integrand, and obtain

$$p_r = \left(\frac{c_1 T^4}{c_2^4} \right) \int_0^{-\infty} z^3 (e^z + e^{2z} + e^{3z} + \dots) dz.$$

Evaluate the integral by integrating term by term and obtain

$$p_r = \left(\frac{6c_1 T^4}{c_2^4} \right) \left(1 + \frac{1}{2^4} + \frac{1}{3^4} + \frac{1}{4^4} + \dots \right).$$

Remark: There are a number of steps in this mathematical procedure that would require justification.

491. In the derivations for curved beams in strength of materials it is necessary to evaluate the two integrals:

$$m = \left(\frac{1}{h} \right) \int_{-h/2}^{h/2} \frac{y dy}{R - y},$$

$$M = 2 \int_{-h/2}^{h/2} \frac{(h^2/4 - y^2)^{1/2}}{R - y} dy.$$

Evaluate both integrals by expanding the integrand into series. Also evaluate the first integral by an exact method.

492. If $KPy = x/(1 - x)$ (Dalton's law), show that

$$KPy = x + x^2 + x^3 + \dots$$

If x is small, show that $KPy = x$, approximately (Raoult's law in gas theory).

493. In railway surveying it is customary to use a formula for the difference in length between the arc ABC and the chord ADC (see Fig. 152). Show that this difference is given exactly by

$$q = r\theta - 2r \sin \frac{\theta}{2}$$

and that this can be reduced to $r\theta^3/24$, which is too large by a number less than $r\theta^5/1,920$.

494. A belt connects, without crossing itself, two pulleys of diameters D and d . The distance between centers is C .

a. Show that the length of the belt (assumed taut) is

$$L = \left(\theta + \frac{\pi}{2} \right) (D) + \left(\frac{\pi}{2} - \theta \right) (d) + 2C \cos \theta,$$

where θ is the angle between the straight section of the belt and the line joining the centers of the two pulleys.

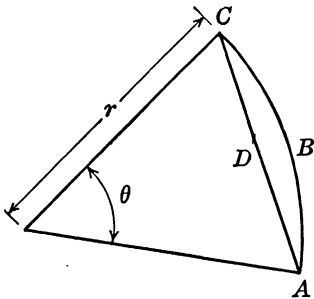

FIG. 152.

b. Expand the preceding formula for L and neglect terms in θ of degree higher than two. What is a formula for the maximum possible error.

495. Gay-Lussac's law in the theory of gases states that the increase in the volume of a gas at any temperature $T^\circ\text{C.}$ for a rise of 1° temperature is a constant fraction of its volume at 0°C. ; *i.e.*,

$$V = V_0(1 + \alpha T).$$

Dalton's law states that the increase in the volume of a gas at any temperature for a rise of 1°C. is a constant fraction of its volume at that temperature; *i.e.*, $V = V_0 e^{\alpha T}$.

Show that if second and higher powers of T are negligible, for ordinary gas calculations, then these two gas laws are equivalent.

496. The electrical engineering derivation of the theory of the electrical breakdown of gases requires the evaluation of the following definite integral:

$$E = \int_a^b \left(\frac{e^{\alpha x}}{x^2} \right) dx,$$

where a and b are both positive constants. Obtain a formula for E by expanding the integrand into a series and integrating term by term.

497. Two ships have masts whose tops are each 100 ft. above the water. How far is one masthead visible from the other?

498. If a straight tunnel were to be bored from Chicago to Detroit (about 300 miles apart) how much distance would be saved? What would be the greatest depth?

499. The process of running a level introduces an error due to the curvature of the earth. What is the correction per mile?

500. A certain road has a 5 per cent grade. What is the actual length of the road along the incline correct to the nearest 0.01 ft. in 100 ft. of horizontal distance? Devise and use an approximate formula to answer this question and prove your accuracy.

501. Assume that the earth is a perfect sphere with radius of 4,000 miles. A band is passed around the earth at the equator so that the band is everywhere 1 yd. away from the earth.

a. What is the difference in lengths of the band and the circumference at the equator?

b. How tall a pole would be required to pull the band taut?

c. What angle (in *b*) at the center of the earth does the straight part of the band subtend?

HYPERBOLIC FUNCTIONS

502. (Taken from the magazine *Industrial and Engineering Chemistry*.) Given that $dy/dx = 2k(x^2 - 4k^2)^{-1/2}$, show that

$$x = 2k \cosh \left(C + \frac{y}{2k} \right),$$

where C is the constant of integration.

503. A charged condenser (C farads) is connected at time $t = 0$ to an inductance L henrys in series with a large resistance R ohms. The current that flows is given by

$$i = \frac{Q\epsilon^{-\alpha t}}{CLk} \sinh kt,$$

where Q is the initial charge on the condenser, $\alpha = R/2L$, and $k = \sqrt{(R/2L)^2 - (1/LC)}$ where k is a real quantity. ($\epsilon = 2.718$, approximately.)

a. Determine the voltage across the inductance e_L if $e = L(di/dt)$.
b. Determine the total charge passing through the inductance q_L if

$$q_L = \int_0^{\infty} i dt.$$

c. Find the voltage across the condenser at any time t if

$$e_C = \frac{1}{C} \left(Q - \int_0^t i dt \right).$$

d. Sketch graphs of e_L , e_C , and the voltage across the resistance ($e_R = Ri$), each as a function of time and show that the last is equal to the sum of the first two.

e. What does the expression for i become if the quantity under the radical for k is negative, i.e., if $k = jp$ (where $j = \sqrt{-1}$)?

504. In studying the rate of formation of carbon monoxide in gas producers, Clement and Haskins (1909) obtained the equation

$$\frac{dx}{dt} = \frac{a}{b} (b^2 - x^2)$$

with the initial condition that the amount of CO at time $t = 0$ is $x = 0$. Show that $x = b \tanh at$.

505. The vector voltage E_s at the sending end of a transmission line is related to the voltage E_r and the current I_r at the receiving end by the equation

$$E_s = E_r \cosh \theta + I_r Z_0 \sinh \theta,$$

where θ depends on the length of the line and Z_0 is the "characteristic line impedance."

Evaluate E_s if $E_r = 127,000 + j0$ volts, $I_r = 200 + j0$ amp., $Z_0 = 398 - j35$, and $\theta = 0.017 + j0.200$.

Remark: All these quantities are given in the form $a + jb$ where $j = \sqrt{-1}$. The values of $\sinh \theta$ and $\cosh \theta$ must be determined in this same form. For this purpose the student may find it necessary as a supplementary problem to verify the following identities:

$$\begin{aligned} \sinh(x + jy) &= \sinh x \cos y + j \cosh x \sin y, \\ \cosh(x + jy) &= \cosh x \cos y + j \sinh x \sin y. \end{aligned}$$

506. The "propagation constant" Γ of an electric wave filter is given by $\cosh \Gamma = (Z_1 + 2Z_2)/(2Z_2)$.

Z_1 and Z_2 are the series and shunt impedances of one section of the filter. The quantity Γ is complex and may be written $\Gamma = +\alpha + j\varphi$.

a. If $Z_1 = j80$ and $Z_2 = j20$, evaluate Γ (show that φ must be zero).

b. If $Z_1 = -j10$ and $Z_2 = j20$, show that α must be zero and evaluate Γ .

c. If $Z_1 = -j50$ and $Z_2 = j10$, show that φ must be $\pm n\pi$ and evaluate Γ .

507. The two following equations give the voltage E_s and the current I_s at the sending end of a particular cable to yield a voltage of 100 volts and current of 2 amp. at a distance of L miles from the sending end.

$$\begin{aligned} E_s &= 100 \cosh 0.02L + 2,000 \sinh 0.02L \text{ volts,} \\ I_s &= 2 \cosh 0.02L + 0.1 \sinh 0.02L \text{ amp.} \end{aligned}$$

a. Sketch graphs of E_s and I_s as functions of L for L from 0 to 200 miles.

b. Expand by Taylor's series in powers of $L - 200$. Stop with the term $(L - 200)^2$.

c. Write $E_s = 1,050e^{0.02L} + f(L)$, $I_s = 1.05e^{0.02L} + g(L)$ and obtain series expansions for $f(L)$ and $g(L)$ through the term in $(L - 200)^2$.

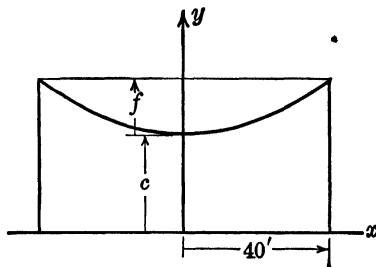

FIG. 153.

508. A catenary cable, $y = c \cosh(x/c)$, has a length of 100 ft. and a span of 80 ft. (see Fig. 153). Determine the sag f .

Solution: First show that $100 = 2 \int_0^{40} \sqrt{1 + \sinh^2 \frac{x}{c}} dx$

$$= 2c \sinh \left(\frac{40}{c} \right).$$

The curve goes through $x = 40$, $y = f + c$ and hence

$$f + c = c \cosh \left(\frac{40}{c} \right).$$

Solve the first equation for c , substitute this value in the second equation, and compute f .

509. A catenary cable, such as shown in Fig. 153, has for its equation: $y = 4,500 \cosh (x/4,500) - 4,420$, x and y in feet, y measured from the ground.

a. What angle does the cable make with either tower if the supporting towers are 800 ft. apart?

b. Determine the length of the cable between the towers, 800 ft. apart.

c. Determine the height of the supporting towers.

d. Determine the sag f .

e. Obtain a parabolic approximation for the cable equation that will be approximately correct for the span ($x = -400$ to $x = +400$ ft.).

f. Now try to answer question (*b*) by aid of your approximate formula from (*e*). You may use either exact integration or Simpson's rule.

Remarks: When a cable or chain hangs from two supports of the same height, the curve assumed by the cable is an arc of a catenary. For certain types of computations it is convenient to approximate the catenary by a parabolic curve. Problem 509 illustrates one type of computation in which the hyperbolic form is much simpler.

510. A tangent line is drawn through the origin with positive slope and tangent to the curve $y = \cosh x$. Determine the inclination of this tangent line:

a. By a graphical method.

b. By some numerical approximation method.

511. One peculiarity of the catenary cable, $y = c \cosh (x/c)$, is that the total stress (pull) at any point (x,y) is equal to $T = wy$, where w is the weight of the cable per foot. Sketch a graph showing the total stress as a function of x if the cable weighs 4 lb. per ft. The equation of the cable is

$$y = 400 \cosh \left(\frac{x}{400} \right)$$

(y is not measured from the ground), and the supports are 600 ft. apart.

Remark: A different manner of stating the equation $T = wy$ would be to say that if at any point (x,y) on the cable, the wire (assumed perfectly flexible) were passed over a frictionless pin and the length of wire allowed to hang downward were just sufficient to reach the x axis, then the cable would not shift its position when released.

INDEX

(Numbers refer to problems)

To avoid the duplication of long lists of numbers, cross references have been cited for many equivalent names and overlapping topics.

A

- Acceleration (*see* Motion)
- Acoustics, 161, 188, 357
- Aerodynamics (*see* Aeronautics;
Fluid flow)
- Aeronautics, airfoils, 165, 293, 294,
347, 352, 461
 - force analysis, 37, 84, 190
 - general, 43, 84, 360, 366, 410
 - motion, 89-92, 298
 - radius of action, 46-48, 92
- Amplifiers (*see* Vacuum tubes)
- Arc length, 433-441, 494
(*See also* Cables)
- Area, 442, 446
- Astronomy, 25

B

- Ballistics, 171, 175, 188, 332, 335,
343, 378, 383, 405
- Beams, 6, 32, 55, 56, 69, 129, 143,
146, 167, 168, 264, 265, 268, 269,
277, 280, 288, 289, 310, 311, 344,
345, 386, 387, 389, 390, 404, 426,
450, 458, 491
- Belts and ropes, 27, 206, 494
- Bernoulli's equation, 10, 336
- Bridges, 120, 173, 174, 182, 272, 438,
445

C

- Cables, catenary, 209, 275, 508-511
parabolic, 12, 170, 173, 440, 441,
483

- Cams, 78, 215, 278
- Carnot cycles, 157, 470
- Center of gravity and moment of
inertia, 121, 314, 447-461
- Ceramics, 42, 339, 431
- Chemical engineering (*see* Chemical
reactions; Fluid flow; Thermo-
dynamics; and similar specific
topics)
 - miscellaneous, 233, 397, 400, 412,
446, 502
- Chemical reactions, 14, 15, 33, 141,
148, 155, 177, 203, 286, 316,
317, 392-396, 475, 504
- Civil engineering (*see* Bridges; High-
ways; Hydraulics; Railroads;
and similar specific topics)
- Columns, 5, 31, 273, 274
- Cost analysis, 295, 300, 307, 318
- Cranks, 99, 103, 195, 223, 227, 319,
320
- Curvature, 344-347

D

- Dimensional analysis, 36, 37, 72, 73
- Dynamics, energy, 270, 385, 407,
455, 456
 - friction and resistance, 27, 107,
109, 126, 152, 172, 206, 214,
309, 472
 - momentum, 399, 405
 - power, 267, 271, 384
 - stability, 7, 75

Dynamics, work, 107, 459, 465-467
 (See also Thermodynamics, Work)
 (See also Aeronautics; Ballistics; Kinematics; Motion; Vibrations)

E

Efficiency, 107, 299, 302
 Elasticity (see Stress-strain analysis)
 Electric circuits, a.c. circuits, general, 11, 34, 77, 95, 97, 163, 183, 419, 423, 424
 impedance, 17-19, 88, 506
 rotating vectors, 102, 112-119
 transmission lines, 210, 211, 307, 505, 507
 wave form, 96, 98, 100-102, 192-194, 197-199, 216, 291, 351, 420-422, 476
 d.c. circuits, 131, 252, 301, 302
 general theory, 266, 291, 380, 381, 401, 476
 (See also Vacuum tubes)
 Kirehnhoff's laws, 34, 54, 65-68
 transients, 26, 49, 200, 201, 284, 350, 403, 486, 503
 Electrical engineering (see Electric circuits; Electromagnetism; Illumination; Vacuum tubes; similar specific topics)
 miscellaneous, 30, 76
 Electromagnetism, electrostatics, 85, 205, 290, 304
 general, 130, 164, 236, 240, 496
 magnetism, 110, 204, 230, 237, 303, 305, 402, 417, 430, 477
 Ellipses, 179-182, 224, 258, 282, 283, 362, 461
 Energy, 270, 385, 402, 404, 407, 455, 456
 Engineering method (see note after 123)
 Entropy, 473

F

Fluid flow, general, 10, 44, 149, 164, 165, 186, 336, 352, 364, 365, 485

Fluid flow, nozzles, 1, 8, 39, 159, 308
 orifices, 13, 38, 41, 160, 427, 428, 471
 pipes, 28, 57, 73, 239, 254, 478, 479
 weirs, 36, 40, 58, 59, 156, 235, 297, 471
 Fluid force, 459, 462-464
 Fluid mechanics (see Fluid flow; Hydraulics)
 Force analysis, 70, 80-84, 86, 87, 93, 107, 109, 190, 214, 241-244, 309, 312
 Friction, 27, 107, 109, 206, 214, 309, 472

G

Gas flow (see Fluid flow)
 Gas laws (see Thermodynamics)
 Geometry, plane, 106, 279
 solid, 7, 9, 53, 60, 61, 358, 497-501
 (See also Maps; specific topics)

H

Harmonic motion (see Electric circuits; Vibrations)
 Heat (see Thermodynamics)
 Highways, 52, 416
 Hydraulics, fluid force, 459, 462-464
 general, 28, 41, 139, 246, 411, 482
 (See also Fluid flow)
 Hydrodynamics (see Fluid flow)
 Hyperbolas, 183-188, 250

I

Illumination, 154, 300, 306, 415
 (See also Optics)
 Impedance, 17-19, 88, 506
 Indicator cards, 157, 185, 413, 470

K

Kinematics, 78, 99, 195, 223, 227, 229, 319, 320, 323, 326, 329, 330
 Kirchhoff's laws (see Electric circuits)

L

Light, 111, 306
 (See also Illumination)

Lissajous figures, 224, 225
 Locus, equation of (*see note after 123*)

M

Machine design, 105, 189, 287, 299, 313
 Magnetism (*see Electromagnetism*)
 Maps, 259-261, 285, 406
 Mechanical engineering (*see Dynamics; Fluid flow; Force analysis; Stress-strain analysis; Thermodynamics; similar specific topics*)
 miscellaneous, 132
 Mechanics (*see Beams; Columns; Dynamics; Force analysis; Plates; Stress-strain analysis*)
 Meteorology, 360
 Mining, 247, 249, 250
 Modulus of elasticity (*see Stress-strain analysis*)
 Moment of inertia (*see Center of gravity*)
 Momentum, 399, 405
 Motion, 35, 45-48, 50, 72, 78, 89-92, 109, 124, 126, 166, 169, 171, 175, 176, 212, 219, 221, 222, 226, 281, 292, 298, 324-328, 331-335, 343, 361, 373-379, 382-384, 388, 391, 418, 425, 453, 454, 457, 487
 (*See also Kinematics; Vibrations*)

N

Nozzles, 1, 8, 39, 159, 308

O

Ohm's law, 131, 252
 Optics, 111, 306
 (*See also Illumination*)
 Orifices, 13, 38, 41, 160, 427, 428, 471

P

Parabolas, 12, 166-178, 272, 278, 279, 440, 441, 461, 475
 Pendulum, 94, 487
 Physical chemistry, 24, 133, 315

Pipes, 57, 73, 239, 254, 478, 479
 Pistons (*see Cranks*)
 Plates, 354, 480, 481
 Power, electrical, 3, 77, 95, 97, 101, 197, 201, 302, 402, 419, 423, 424
 mechanical, 267, 271, 384

R

Radiation, 216, 351, 490
 Radio (*see Electric circuits; Vacuum tubes*)
 Railroads, curves, 220, 346, 493
 train resistance, 126, 152, 172
 Reflectors, 442
 Resistance, 130
 electrical (*see Electric circuits*)
 mechanical, 126, 152, 172
 Reynolds number, 239
 Ropes and belts, 27, 206, 494
 Rotating vectors, 102, 112-119

S

Simple harmonic motion (*see Electric circuits; Vibrations*)
 Slide rule, 44, 337
 Snell's law, 111
 Sound, 161, 188, 357
 Specific gravity, 9, 53, 60
 Specific heat, 135, 263, 340, 367, 409, 414, 429
 Spillways (*see Weirs*)
 Stability, 7, 75
 Strength of materials (*see Beams; Columns; Plates; Stress-strain analysis*)
 Stress-strain analysis, materials, 122, 147, 231, 232
 miscellaneous, 125, 142, 162, 179, 187, 253, 256, 258, 313, 348, 353, 362, 363, 398, 407, 439
 (*See also Beams; Columns; Plates*)
 Structural design, 181, 245, 248, 257

T

Temperature of explosion, 14, 15
 Thermodynamics, entropy, 473

Thermodynamics, fluid flow, 1, 8, 10,
 39, 44, 159, 308
 gas laws, 2, 21, 22, 29, 44, 137, 138,
 151, 157, 158, 185, 251, 338,
 356, 359, 360, 369-371, 432,
 492, 495
 heat conduction, 136, 140, 150,
 164, 474
 radiation, 490
 specific heat, 135, 263, 340, 367,
 409, 414, 429
 temperature scales, 123
 work, 23, 134, 208, 355, 413, 468-
 470

Tides, 104

Tunnels, 247, 249, 250

V

Vacuum tubes, 3, 64, 127, 153, 178,
 184, 228, 234, 262, 276

Vectors (*see* Force analysis; Rotating
 vectors)

Velocity (*see* Motion)

Vibrations, general, 16, 20, 51, 62,
 63, 71, 74, 75, 94, 207, 218, 224,
 225, 321

simple harmonic motion, 35, 103,
 104, 125, 144, 145, 191, 195,
 196, 322, 349

(*See also* Electric circuits)

Volume, 61, 358, 443-445

W

Weirs, 36, 40, 58, 59, 156, 235, 297,
 471

Work, mechanical, 107, 459, 465-
 467, 477

thermodynamical, 23, 134, 208,
 355, 413, 468-470

ANSWERS

- 2.** $v_1 = v_2(p_2/p_1)^{1/n}$. **4a.** $x/\sqrt{ax+b}$; $b. 1/x\sqrt{ax-b}$.
5. $w = 8.51$ in. **6.** 15.1 ft. **7.** $h = 0.707r$.
8. $r = \left(\frac{2}{k+1}\right)^{k/(k-1)}$. **9.** $z = h - h[1 - (w/W)]^{1/2}$.
10. $u_A^2 - u_B^2 = 2g(p_B V_B - p_A V_A - w)$.
11a. $m = -5 \pm j100$; $b. m = -\frac{R}{2L} \pm j\sqrt{\frac{1}{LC} - \frac{R^2}{4L^2}}$
12a. 12.19 ft.; $b.$ 12.24 ft.
13a. $y = \frac{4A^2 t^2}{M^2} + \frac{4At\sqrt{h_1}}{M}$; $b. y = 1.01 + 2.01\sqrt{h_1}$ ft.
14. $t = 3350^\circ\text{C.}$, $T = 3350 + 273 = 3623^\circ\text{abs.}$
15. $t = 2180^\circ\text{C.}$ **16.** $f = 1/(1+u)$.
17a. $20.8 - j5.6$; **18.** $Z = 4 + j2$ ohms.
b. $96 + j66$; **19.** $G = R/(R^2 + X^2)$, $B = X/(R^2 + X^2)$.
c. $3 + j3$. **21.** $T = 412^\circ$.
22. $\Delta s = 0.3972$. **23.** $v_1 = 1.71$ cu. ft., $W = -4,840$ ft.-lb.
24. $t = 78.2M^{0.398} - 393$, $M = 141^\circ$.
25. About 1 to 40. **26.** $F = 18.0$ lb.
28a. $v = 24.9\sqrt{Pd}$; $b.$ 181 lb. per sq. in.
30. $RK^2 - DK + R = 0$. **31.** $\varphi = \frac{s}{\pi^2 E} - \left(\frac{l}{r}\right)^{-2}$.
32. $M_1 = M_3 = 0$, $M_3 = -wL^2/14$, **33.** $W = 850.8$ lb., $S = 90.8$ lb.,
 $M_2 = M_4 = -3wL^2/28$. $N = 58.4$ lb.
34. $L_1 = 6.82 - j9.06$ amp., $I_2 = 6.51 - j1.60$ amp.
35. $r = 10.5$ in., $\omega = 9.22$ radians per second.
36. $Q = 450$ cu. ft. per sec.
37. $L = 0.0035AV^2$. **39a.** 0.9877; 0.9943.
40. $K = 3.31 + \frac{7.45h}{H} + \frac{0.007}{H^{3/2}}$ **43.** $Q_0 = \frac{Q}{2} + \frac{Q^2}{8W} + \dots$
44. 1.064; 0.957; 0.922; 1.008. **46.** $\bar{S} = 2S_1 S_2 / (S_1 + S_2)$.
47. 192 miles; 2 hr. 24 min. **48a.** 105 miles per hour;
49. $i = 4e^{-2t}$ amp. $b.$ 420 miles and 450 miles.
50. Distance during t sec. = $5.47t^2$ ft.
51. Logarithmic decrement = $c\pi/\omega$.
52. 7,840 miles; $1,760x^2 + 399x$. **53.** $h = -3.41$ in.
54. $-249,000$; $-749 + j10,050$. **55.** $x = 0.422L$.
56. $x = 5.20$ ft. **57.** $d = 3.40$ in.

58. 2.04 ft. 59. $h = 1.48$ ft.
 60. $t = 0.089$ in. 61. $r = 2.69$ in., $h = 5.51$ in.
 62. $F = \frac{1}{2}, (2 \pm \sqrt{2})/2$.
 63a. $x = 9.664; 104.8; 292.6$; b. $p^2 = 2\beta, (2 \pm \sqrt{2})\beta$;
 c. $p^2 = 25,600; 80,400$; d. $\omega = \pm 1,080; \pm 2,180; \pm 5,630$.
 65a. $I_1 = 3.46$ amp., $I_2 = 1.17$ amp., $I_3 = 1.50$ amp.;
 c. $I_1 = 0.3E_1 + 0.06E_2 + 0.08E_3, I_2 = 0.06E_1 + 0.092E_2 + 0.056E_3,$
 $I_3 = 0.08E_1 + 0.056E_2 + 0.208E_3$.
 67b. $I_g = 0.000,003,24$ amp.
 68. $I_a = 12.9 + j10$ amp., $I_b = 6.6 + j8.2$ amp., $I_c = 3.9 + j10.8$ amp.
 69. $M_2 = -11,300$ lb.; $M_3 = -15,200$ lb.;
 $M_4 = -13,500$ lb.; $M_5 = -7,600$ lb.
 70. $P = 51$ lb.
 71. $F_1 = 1.707, y_1 = 1, y_2 = 1.414, y_3 = 1$;
 $F_2 = 0.500, y_1 = 1, y_2 = 0, y_3 = -1$;
 $F_3 = 0.293, y_1 = 1, y_2 = -1.414, y_3 = 1$.
 73. $x = n - 2, y = n - 1, z = 2 - n$.
 75b. Roots are $-1, -2, (-1 \pm i\sqrt{3})/2$. 80. $P = 137$ lb., $T = 146$ lb.
 81. Resultant = 127.7 lb., $\theta = 162^\circ 58'$.
 82. Resultant = 18.1 lb., $\theta = 189^\circ$. 83. $6^\circ 39'$.
 84. $8,960$ lb., 785 lb. 85. $d = 1.9$ meters.
 86. $\theta = \varphi = \cos^{-1}(\frac{7}{8}) = 28^\circ 57'$; $m = 30.2$ ft.; $p = 17.8$ ft.; $P = 413$ lb.
 88. $Z = 13.42$ ohms; $\theta = 26^\circ 34'$; $I = 7.45$ amp.; $P = 667$ watts.
 89a. $\theta = 8^\circ 12'$; 90a. $\theta = 8^\circ 12'$;
 b. $98^\circ 12'$ track; b. $261^\circ 48'$ track;
 c. 130 miles per hour. c. 78 miles per hour.
 91. $t = 1$ hr. 29 min.; $\theta = 10.9^\circ$; heading = 76.6° track.
 94a. $1.000,076; 1.0161; 1.054$.
 95. $p = 85 - 30 \cos 240\pi t - 50 \cos 480\pi t - 5 \cos 720\pi t$.
 96. $e = 62.8 \sin (120\pi t - 0.124)$.
 98. $e = 100 \sin 4,000,000t + 35 \sin 4,004,000t + 35 \sin 3,996,000t$
 $- 15 \sin 4,008,000t - 15 \sin 3,992,000t$.
 99d. $x = 0.98992L + 0.2L \cos \theta + 0.010102L \cos 2\theta - 0.000,025,8L \cos 4\theta$;
 e. $x = \left(L - \frac{r^2}{4L}\right) + r \cos \theta + \frac{r^2 \cos 2\theta}{4L}$,
 $= 0.99L + 0.2L \cos \theta + 0.01L \cos 2\theta$.
 100. 51.5 volts, 95.8 volts.
 105b. $N = 2 \cos^{-1} \frac{r+a}{r+b}$; $r = \frac{b \cos (N/2) - a}{1 - \cos (N/2)}$. 106. $r = 30/19$ in.
 107. $\theta = 35^\circ 26'$. 108. $\theta = 41^\circ 49'$.
 110. $0^\circ; 60^\circ 15'; 89^\circ 21'; 89^\circ 47'; 89^\circ 54'; 89^\circ 58'$.
 111. $0^\circ; 0^\circ 45'; 7^\circ 30'; 22^\circ 5'; 32^\circ 8'; 40^\circ 39'; 48^\circ 46'$.
 112b. 245 watts; c. 103.5 watts. 113d. $P = EI \cos \theta$.
 114a. (1) $10 + j0$; (2) $48.2 / 51^\circ 29' = 30.0 + j37.6 = 48.2e^{i0.898}$;
 (3) $0 + j16$; (4) $0 - j2,500$;
 b. (2) $\dot{I} = 2.08 / -51^\circ 29'$, etc.

115. $V_{a1} = 12.4 + j12.4$; $V_{b1} = +16.9 - j4.55$; $V_{c1} = -4.55 + j16.9$.

116. $V_{a0} = (\frac{1}{3})(V_a + V_b + V_c)$; $V_{a1} = (\frac{1}{3})(V_a + aV_b + a^2V_c)$;
 $V_{a2} = (\frac{1}{3})(V_a + a^2V_b + aV_c)$.

117. $I_1 = 55.0 / -105^\circ$; $I_2 = 110 / -105^\circ$; $I_3 = 530 / -117^\circ$.

118a. (1) $4 + j8$; (2) $96.6 + j25.9$; (3) $200 / 156.9^\circ$; (4) $10 / 26^\circ 34'$;

(5) $2.303 + j1.047$; (6) $0.729 + j0.685$; (7) $-8 + j13.9$;

b. (1) $10 / 60^\circ$; c. $R = 34.9$, $\theta = 32.5^\circ$.

119a. $\alpha = 0$, $\beta = 0.357$ radian; b. $\alpha + j\beta = 0.020 + j1.98$.

120. Member	Slope	Inclination
DE	-0.1	174°17'
EF	-0.4	158°12'

121. (4.75, 3.25).

122. 30,000,000 lb. per sq. in.

123. Slope = $\frac{5}{6}$.

124a. $P(t_1, a_1t_1)$, $Q(t_1 + t_2, a_1t_1 - a_2t_2)$, $R(T, 0)$;

b. $2A = a_1t_1T + a_1t_1t_2 + a_2t_1t_2 - a_2t_2T$;

c. $(a_1 + a_2)(a_1 + a_3)t_1^2 - 2a_3Tt_1(a_1 + a_2) + 2A(a_3 - a_2) + a_2a_3T^2 = 0$.

125. 300 in.-lb.

126. 2,000 lb. = F intercept.

128a. $W_{\text{beam}} = 100x$; b. $F = 400 - 40x$; c. $W_{\text{sand}} = 400x - 20x^2$;

d. $W_{\text{total}} = 500x - 20x^2$.

129a. $x = 0$ to $x = 3$: $V = 6,600 - 100x$;

$x = 3$ to $x = 6$: $V = 4,600 - 100x$;

$x = 6$ to $x = 7$: $V = 600 - 100x$;

$x = 7$ to $x = 12$: $V = -5,400 - 100x$;

b. 0;

c. $x = 0$ to $x = 3$: $A = 6,600 - 50x^2$;

$x = 3$ to $x = 6$: $A = 6,000 + 4,600x - 50x^2$;

$x = 6$ to $x = 7$: $A = 30,000 + 600x - 50x^2$;

$x = 7$ to $x = 12$: $A = 72,000 - 5,400x - 50x^2$.

130. $R = 0.0203 + 0.000,083T$. The resistance of this wire is always equal to its resistance at zero temperature plus 0.000,083 times the temperature in degrees centigrade.

132. $R = 1.00$ is the consumption when no alcohol is added; the slope, 0.0060, is the rate at which the consumption increases per unit of added alcohol.

134. $W = 1,840$ ft.-lb.

135. 1.66 calories.

136. $T = 10 + 7.5x$.

138a. EF : $T = 2.083H - 1,002$; CD : $T = H - 70$; b. 12,000.

139. 660 tons.

141. (0.085, 0.496).

152. $R \approx 3.5 + 0.0055S^2$.

155. $x = 0.42$.

161. 4.33; 3.40; 2.93.

163. $RI_1^2 - EI_1 + RI_2^2 = 0$.

167. X intercepts: $x = \frac{3 \pm \sqrt{3}}{6}L$; Y intercept: $M = -\frac{wL^2}{12}$;

vertex: $x = L/2$, $M = wL^2/24$.

168a. $y = -0.104$ ft.

169b. $t = 5$ sec.

170. 18.3 ft.

172. $L = 6.0$ lb. per ton, $S = 10$ miles per hour.

173. $AC = (p^2 + L^2)^{1/2}$; $CD = 3p/4$; $BD = (\frac{1}{4})(9p^2 + 16L^2)^{1/2}$.

174. 136 ft.

175a. $y = 9x/8 - 3x^2/8,000$, x, y in feet; $b. 844$ ft.; $c. \theta = 47.4^\circ$.

176. 11.3 radians per second.

178. Vertex at $(-40, 0)$.

180b. $a = 4.39$; $c.$ Error = 0.08, or a 6 per cent error;

$$d. a = \frac{k}{3} + 2b - \frac{\sqrt{k^2 + 9b^2}}{3} \text{ if } b > 0.193k.$$

181b. $A = (\pi/82,944)(144 - x)(108 - x)$.

182a. 10.8 ft.; 13.3 ft.; 14.7 ft.; $b. 54.3$ cu. yd.

183a. $f = 1,010,000$; $b. f = 20.2$.

185.	Curve	(a)	(b)
	AB	$V = 0.4$	$V = 0.4$
	BC	$pV = 15$	$pV = 2,160$
	CD	$p = 15$	$p = 2,160$
	DE	$V = 2$	$V = 2$
	EF	$pV = 80$	$pV = 11,520$
	AF	$p = 100$	$p = 14,400$

187b. An asymptote: $S_t = s_t$; $c.$ an asymptote: $S_t = 0$.

188b. $(x^2/1.06) - (y^2/5.19) = 1$.

189. Coordinates may be obtained from $x = 3 + 0.866x' - 0.5y'$; $y = 5 + 0.5x' + 0.866y'$, where x' is along AH and y' along BA .

190. $L = N \cos \alpha - T \sin \alpha$; $D = N \sin \alpha + T \cos \alpha$.

191c. $y' = y$, $\omega' = \omega + \alpha$.

192. $i = I \cos(\omega t - \theta)$, where $I^2 = I_1^2 + I_2^2 + 2I_1I_2 \cos \theta$ and $\tan \theta = I_2 \sin \theta / (I_1 + I_2 \cos \theta)$.

193. $i_R = 0$.

194. $i_3 = 0.518I \cos(2\pi ft - 4.45)$.

196. 30,170 lb., 13,830 lb.

199b. $e_{\max} = 150$ volts.

202. Plot $1/E_m$ in terms of η ; $\eta \approx 0.74$; $E_m \approx 68$.

204. $\phi = 0$ and the wires touch.

205b. $r = 0.37R$, $RE_m = 2.72V$.

206b. $T_1 = 2,640$ lb.

207b. $A = 0.5$, $\theta = 0.643$ radian; $c. t = 230$ sec.

208c. $W = 181$ ft.-lb.

209. $c = 33.8$; $f = 26.6$.

210a.	L	E_s volts	I_s amp.
	10	142	0.224
	100	1,006	1.115

211a. $-0.835 + j0.355$;

$b. -1.27 + j0.233$.

214c. $\theta = 73.3^\circ$. For any angle θ between 73.3 and 90° the block will not move.

219. $x = 10 \cos 0.4t^2$; $y = 10 \sin 0.4t^2$.

222c. Slope = -6 .

- 223d. $x = \pm \sqrt{r^2 - 4y^2} + \frac{1}{2} \sqrt{L^2 - 4y^2}$.
- 224a. $x = b \cos \omega t$, $y = a \cos (\omega t - \alpha)$; $b \cdot \sin \alpha = c/a = d/b$.
- 226b. 22.7 ft. per sec.
227. P : $x = 10 \cos \omega t$, $y = 10 \sin \omega t$;
 M : $x = 15 \cos \omega t$, $y = 5 \sin \omega t$.
229. $M_1: x^2y^2 = (a - y)^2(a^2 - y^2)$; $M_2: 4x^2y^2 = (a - y)^2(a^2 - 4y^2)$.
231. $s = 35 + 3,960,000\epsilon - 1,255,000,000\epsilon^2$;
 $s_{\max} = 3,150$ lb. per sq. in. when $\epsilon = 0.00158$ in. per in.
- 232a. $s = 2,880,000\epsilon$; $b. s = -100 + 4,000,000\epsilon - 94,900,000\epsilon^2$;
 $s_{\max} = 42,000$ lb. per sq. in. when $\epsilon = 0.021$ in. per in.
- 233a. $\theta = 4.59V^2 + 9.02V + 0.50$.
234. $i_b = 4.18 + 0.274e_c + 0.00351e_c^2$. 235. $C = 3.31$, $n = 1.52$.
236. $i = 26,500,000 \sqrt{T}e^{-55,500/T}$; $i = 81.4T^2e^{-53,000/T}$.
237. $a = 15.5$, $b = 1.75$.
- 241b. $\alpha = 119^\circ 40'$, $\beta = 72^\circ 22'$, $\gamma = 143^\circ 55'$;
 c. $F_x = -40.4$ lb., $F_y = 24.4$ lb., $F_z = -64.7$ lb.
- 242c. 29.2 lb., $\alpha = 54.3^\circ$, $\beta = 65.9^\circ$, $\gamma = 62.2^\circ$; $d. 27.3^\circ$.
- 243b. $R = 193$ lb., $\alpha = 42.8^\circ$, $\beta = 53.9^\circ$, $\gamma = 110.4^\circ$.
244. $T = 389$ lb., $P = 625$ lb., $B_x = 97.2$ lb., $B_y = 583$ lb., $B_z = 1,083$ lb.,
 $B = 1,230$ lb. at $\alpha = 85.5^\circ$, $\beta = 62.3^\circ$, $\gamma = 28.5^\circ$.

245.	Member	Length	Direction cosines
	<i>AO</i>	10	1; 0; 0
	<i>BE</i>	43.9	-0.570; -0.455; +0.683
	<i>CO</i>	32.2	-0.186; +0.311; +0.932
	<i>DO</i>	50.4	-0.119; -0.795; +0.596
	<i>EO</i>	5	1; 0; 0.

246. $88^\circ 53'$.

247b. (1) 359 ft.; (2) $N.26^\circ 37'W.$; (3) 1.7 per cent; (4) 1.0° .

248.	Wire	Length, ft.	Direction angles
	<i>CB</i>	157	112.3° ; 104.7° ; 27.3°
	<i>DB</i>	180	63.6° ; 96.4° ; 27.3°
	<i>EB</i>	152	93.8° ; 62.7° ; 27.6°

x is positive in east direction, y in north, and z upward.

249b. $82x + 80y + 57z = 28,500$; $c. 302$ ft.; 50.1° , 51.3° , 62.9° .

250e. E on AB : (333, 250, -333); F on CD : (420, 474, -333).

263. When $t = 20^\circ C.$, $dQ/dt = 0.5662$.

266. $i = (E_0/r)\epsilon^{-t/Cr}$ in both cases.

267. $P = dW/dt$.

268. $V = wL/2 - wx$.

269. For $0 < x < L/2$: $V = P/2$; $L/2 < x < L$: $V = -P/2$;
discontinuous at $x = L/2$.

270. $F = k/r^2$. 271. $P = 16$ ft.-lb. per sec. 272. 10.6 ft.

273b. $P/A = p - (2Lp/3\pi r)(p/3E)^{1/2}$. 274. $b^2 = 4am$.

275. $\cot^{-1}\left(\frac{k \sinh 1}{a}\right)$. 276a. -3.18 ;
b. $i_b = 0.2e_c + 9$.

277. $27y = 704kx - 6,400k$.

278. $a = 4$, $b = -2$, and $y = x - 1$ is the common tangent.

279. Join points (1,0) and (9.5,8.5) to obtain the common tangent line.

280. $y = -\frac{7wL^4}{384EI}$. 281. $y = x + 3\sqrt{2}$ ft.

286b. $Y = (H/P)x$; c. $x = (H - P)x_2^2/P$.

287. $x = 1.068$ in., $y = 1.141$ in.

288c. $x = 0$ and $x = 12$; d. $x = 6$, $M = 31,800$ lb.-ft.

289a. At the wall $M = -wL^2/12$. Notice that though $dM/dx = 0$ at $x = L/2$, the corresponding value of M is numerically less than the value for M at the wall. b. $x = 0.211L$ and $x = 0.789L$.

290b. $x = \pm 0.707a$; c. $x = 0$, $\pm 1.225a$.

292.	t	0	10	20	30	40	50	60	70
	ds/dt	0	31	59	80	93	96	92	81

293. $y = 0.29690\sqrt{x} - 0.12600x - 0.35160x^2 + 0.28430x^3 - 0.10150x^4$.

295. $d = (5B/2A)^{1/2}$. 297. $D = 2H/3$.

300a. $\frac{V}{V_0} = \left(\frac{bP_0 B_3 - B_2}{c B_2 - B_5}\right)^{1/(B_5 - B_3)}$; b. 103 volts.

302. $\eta = \frac{E}{E + 2\sqrt{P_0 R}}$ when $P_0 = I^2 R$. 304. $R = cr$, $E_m = Vc/R$.

305. $s = 0.851D$, $t = 0.528D$. 306. 3.54 ft.

308. $p_2 = p_1 \left(\frac{2}{k+1}\right)^{k/(k-1)}$; 0.528.

309. $P_{\max} = 100$ lb. when $\theta = 90^\circ$; $P_{\min} = 19.6$ lb. when $\theta = 11.3^\circ$.

310a. $x = 5.16$ ft.

311. $x = 0.577L$, $y = -0.005$, $42wL^4/EI$.

312. 10 ft.

313. $3d = D$.

314a. $\tan 2\theta = 2P_{xy}/(I_y - I_x)$;

b. the angles differ by an odd multiple of 45° .

315. $t = 3.9^\circ\text{C}$.

316b. $x = 0.417$, $v = 0.100$.

317. $A_{\max} = \frac{0.20}{1-a} [a^{-a/(a-1)} - a^{-1/(a-1)}]$, where $a = k_2/k_1$.

318. 949 articles per day.

319d.	t	$\frac{dx}{dt}$ exact	$\frac{dx}{dt}$ approx.	$\frac{d^2x}{dt^2}$ exact	$\frac{d^2x}{dt^2}$ approx.
	0	0	0	0.30	0.30
	$\pi/4$	0.40406	0.40355	0.27730	0.27678
	$\pi/2$	0.5	0.5	-0.0510	-0.0500
	π	0	0	-0.20	-0.20

e. Maximum force = $0.30m$.

320b. -340 lb.; c. 400 lb.

321a. $t = 0.063$ sec.; $V = -3.56$ ft. per sec.; $y = 0.0683$ ft.;

c. $y_2/y_1 = -0.9908$.

323. $|V| = 0.307$ ft. per sec. at 130.7° .

$|a| = 0.254$ ft. per sec. per sec. at 190.4° .

324a. $V_A = 16$ ft. per sec., $V_B = 12$ ft. per sec.;

b. $|V_{A/B}| = 20$ ft. per sec. at -36.9° .

325a. 5 r.p.s.; b. $|V| = 100\pi |\sin 20\pi t|$ ft. per sec.;

c. $|a| = 500\pi^2 \sqrt{26 - 10 \cos 40\pi t}$ ft. per sec. per sec.;

d. $t = n/40$ where n is any positive or negative integer.

326a. $x = 10 \cos \theta - 2 \cos 5\theta$; $y = 10 \sin \theta - 2 \sin 5\theta$, where $\theta = 0.4\pi t$;

b. $x^2 - 40 \cos 1.6\pi t - 20x \cos 0.4\pi t + 4x \cos 2\pi t = 2,396$; c. $V = 0$;

d. $a = 63.2$ in. per sec. per sec. at 0° ;

e. $V = 0$, $a = 63.2$ in. per sec. per sec.

327a. 5 r.p.s.; b. $|V| = 60\pi |\sin 20\pi t|$ ft. per sec.; c. $|a| = 3\omega^2 \sqrt{10 + 6 \cos 4\theta}$ ft. per sec. per sec.

328. $|V_{\max}| = 12$ ft. per sec.; $|a_{\max}| = 9$ ft. per sec. per sec.

329a. $|V| = 8$ ft. per sec. at 210° ;

$|a| = 20$ ft. per sec. per sec. at $263^\circ 8'$;

$a_x = 4 \cos \theta (d\theta/dt)^2 + 4 \sin \theta (d^2\theta/dt^2)$;

$a_y = -4 \sin \theta (d\theta/dt)^2 + 4 \cos \theta (d^2\theta/dt^2)$;

b. $|V| = 4 \frac{d\theta}{dt}$, $a_t = \frac{d|V|}{dt} = -12$ ft. per sec. per sec.;

$a_n = 16$ ft. per sec. per sec.

330. $\omega_A = 4$ radians per second, $\alpha_A = 8.36$ radians per second per second.

$|V_C| = 8$ ft. per second at 135° ;

$|a_C| = 32$ ft. per second per second at 225° ;

$|V_B| = 8$ ft. per second at 225° ;

$|a_B| = 36$ ft. per second per second at -72.6° .

332. $x = b/2$ ft.

333. $|V| = (r^2\omega^2 + g^2t^2)^{1/2}$; $|a| = (r^2\omega^4 + g^2)^{1/2}$.

334. $|V| = \left(\frac{4\pi^2 r^2}{b^2} \cos^2 \frac{2\pi t}{b} + g^2 t^2 \right)^{1/2}$; $|a| = \left(\frac{16\pi^4 r^2}{b^4} \sin^2 \frac{2\pi t}{b} + g^2 \right)^{1/2}$.

335. $x = 250t$, $y = \frac{1}{2}gt^2 + 250t\sqrt{3}$ with axes through the bomber and y axis positive downward; when $t = 4$ sec., $x = 1,000$ ft., and $y = 2,000$ ft.

336. $\Delta p = -\rho v \overline{\Delta v}$.

337. $\Delta y = 0.264$ in.

- 338a. $dv = \frac{bv^3 - v^4}{pv^3 - av + ab} dp$; b. $dv = \left(\frac{nR}{p}\right) dT$.
339. 6.25 in., 113 cu. in. 340. $dQ = 0.1b + 60c$.
341. $dy = 0.000,59$. 343. 2,560 ft. per sec.
344. Relative error = $1 - [1 + (dy/dx)^2]^{-3/2}$; largest percentage error is 0.375 per cent.
345. When $x = L/2$, $R = 320$ ft. 346. Not defined; 600 ft., 254 ft.
347. $R = a_0^2/2 = 0.0441$. 349. $Y = -(qt/2\omega) \cos \omega t$.
350. $\lim_{R \rightarrow 0} (i) = Et/L$. 351. Limit in each case is zero.
352. $\theta = 0$: $x = 0$, $y = (B - A)(1 - 2/\pi)$;
 $\theta = \pi/2$: $y = 0$, $x = B(1 - 2/\pi) + 2/\pi$.
353. $A = (P/\sigma)e^{\gamma z/\sigma}$.
354. At $r = 0$: $w = Pa^2/16\pi N$, $dw/dr = 0$, M does not exist;
 at $r = a$: $M = -P/4\pi$.
- 355b. $W = p_1v_1 \ln (v_2/v_1)$, when $p_1v_1 = p_2v_2$.
356. $p_1v_1 \ln (v_2/v_1)$. 357. $y = (y_1)^x$.
358. $dV/dt = 2.4kD^2$. 359. $dV/dt = -0.034$ cu. in. per sec.
360. $dp/dt = -1.26$ lb. per sq. ft. per sec.
- 361a. 10.2 ft. per sec.; b. -0.041 ft. per sec. per sec.
- 362a. Zero; c. $\tau_{xz} = -\frac{2My}{\pi ab^3}$, $\tau_{yz} = \frac{2Mx}{\pi a^3b}$.
- 363b. $\sigma_x = 2(x - a)$, $\sigma_y = 2mna + 2ny - 2my - 6mnx$,
 $\tau_{xy} = 2mx - 2nx - 2y - ma$;
 c. $\sigma_x \approx$ curvature in y direction, $\sigma_y \approx$ curvature in x direction.
- 364a. $a/r^2 = a/(x^2 + y^2)$; b. $V_x = (2 - x^2)/8$, $V_y = -xy/8$.
365. $v_x = -u + \frac{ua^2(x^2 - y^2)}{(x^2 + y^2)^2}$; $v_y = \frac{2ua^2xy}{(x^2 + y^2)^2}$.
- 367a. 0.4228 B.t.u. per lb.; b. 0.2988 B.t.u. per lb.
- 368b. (1) $-2k/a$; (2) $-2k/b$. 369b. $dT = (1/k)(V dp + p dV)$.
370. Six different first partial derivatives.
371. $(\delta Q/\delta V)_T = (P/R)(c_p - c_v)$; $(\delta Q/\delta P)_T = (V/R)(c_v - c_p)$;
 $(\delta Q/\delta P)_V = (V/R)c_v$, $(\delta Q/\delta V)_P = (P/R)c_p$.
373. 13.3 ft. per sec. 374. $s = 0.008t^3 - 0.4t^2 + 10t$.
375. 200 sec. 376. 51.6 ft. per sec.; 1.71 sec. 377. 5.47 sec.; 96.2 ft.
- 378c. (1) $\Delta x = 22$ miles, $\Delta y = 5$ miles; (2) $\Delta x = 10$ miles, $\Delta y = 7$ miles.
- 379a. $\alpha = -17$ radians per sec. per sec.;
 b. 104 revolutions; c. α increasing.
380. $i = 1.326(1 - \cos 120\pi t)$, $i = 1.99$ amp.
381. $g_0 = 1/\sqrt{LC}$, $\eta = \sin^{-1} [(R/2)\sqrt{C/L}]$; $k = (Eg_0/g) \cos \eta$.
382. $v_{240} = 13.5$ ft. per sec.; $s_{240} = 4,730$ ft.

383.	h ft.	x ft.	Angle	Impact speed, miles per hour
	10,000	11,000	28.8°	625
	20,000	15,500	21.1°	833
	30,000	19,000	17.5°	995

385. The total energy is constant.

386. For $0 < x < \frac{2L}{3}$: $EIy = \frac{Px}{162}(9x^2 - 8L^2)$,

$$\frac{2L}{3} < x < L: EIy = \frac{Px}{162}(9x^2 - 8L^2) - \frac{P}{6}\left(x - \frac{2L}{3}\right)^3.$$

387. $18EIy = 5,000x^3 - 15x^5 - 350,000x$; $y_{\min} = -0.49$ in.

388. 6.25 ft.

389. $y = 0.000,34x^3 - 0.000,014,2x^4 - 0.024,5x$ ft.;

when $x = 6$ ft., $y = -0.092$ ft.

391b. $0 < t < 10$: $s = 0.04t^2$ miles; $10 < t < 100$: $s = 0.8t - 4$;

$100 < t < 105$: $s = 16.8t - 0.08t^2 - 804$; $105 < t < 120$: $s = 78$.

392. $kt = \ln \left(\frac{a - x_0}{a - x} \right)^A \left(\frac{b - x_0}{b - x} \right)^B \left(\frac{c - x_0}{c - x} \right)^C$,

$$\text{where } A = \frac{1}{(b-a)(c-a)}, B = \frac{1}{(a-b)(c-b)},$$

$$\text{and } C = \frac{1}{(a-c)(b-c)}.$$

393. $x = 10.0(1 - e^{-0.00154t})$.

394. $T = (\ln 2)/k$.

395. $k = 0.002,397$ if t is in minutes; $T = 289$ min.

396. $y^2 = 2pt$.

397c. $E = \frac{C}{n-1} \left(\frac{1}{L_2^{n-1}} - \frac{1}{L_1^{n-1}} \right)$.

398a. $A(x) = (P/\sigma) e^{\gamma x/\sigma}$; b. $A(12) = 2.30$ sq. in.

399. 246 lb.-sec.

400a. $\frac{y_{n0} - Y_{n-1}}{EL} (e^{EL} - 1) + Y_{n-1}$;

b. $A = 182 + 0.251t + 0.000,187t^2$; c. $V = \pi k a^2 e^{v/k} - \pi k a^2$;

d. $\left(\frac{k}{g} \right) \left[\frac{1}{2} \ln \frac{(k+t)^2}{k^2 - kt + t^2} + \sqrt{3} \tan^{-1} \frac{2t-k}{k\sqrt{3}} \right]_{t_0}^t$,

where $t^3 = w$ and $k^3 = g$;

e. $\theta(x) = 0.819e^{-14.627x} + 0.106e^{-82.22x} + 0.0190e^{-212x} + 0.0559$;

f. $\frac{(61.6 - C_e)(63.6 - C_e)}{(62.6 - C_e)^2} \ln \frac{62.6}{62.6 - c_0} + \frac{1}{(62.6 - C_e)^2} \ln \frac{C_e}{C_e - c_0}$

$$+ \frac{c_0}{62.6(62.6 - C_e)(62.6 - c_0)}$$

401. $i = 0.402$ amp.

403c. $Q = 2E(CT/\pi R)^{1/2}$, $W = EQ$.

404. P.E. = $EI\pi^4 y_0^2/64L^3$,

405. 9,610 lb.-sec.

406. 4,528 units, 3,600 units.

407. 8.73 ft.-lb.

408. 0.385.

409. 1,750 calories; 1,590 calories.

410a. $(RG^2/12\pi^2)(1/r_0^3 - 1/r^3)$;

$$b. \left(\frac{R_s V^2}{12}\right) \left(s \sqrt{9 - s^2} + 9 \sin^{-1} \frac{s}{3}\right).$$

412. Results by Simpson's rule: 6.359; 5.816; 6.045.

413. Simpson's rule: 6 subdivisions: 0.749; 12 subdivisions: 0.783.

414a. $H_T = 12.04124$, $H_S = 12.04113$; b. $H = 12.000,00$;

$$c. s = 1.006,389 - 0.000,486\theta, H = 12.041,71.$$

415. 0.722

416. 3,480 cu. yd.

417b. $w_T = 15.5$; $w_S = 15.0$; $B = H/(0.0508H + 0.208)$; $w = 13.9$.

418. 24 miles.

419a. 277 watts.

420a. $2\pi/E$, 0; b. $0.707E$; c. 170 volts.

421b. (1) 75.5 volts; (2) 0; c. 79.4 volts.

422a. $(2/\pi)(I_1 + I_3/3 + I_5/5 + \dots + I_k/k)$;

$$b. 0.707(I_1^2 + I_3^2 + \dots + I_k^2)^{1/2}.$$

423. $P = 0.5(E_1 I_1 + E_3 I_3 + \dots + E_k I_k)$.424a. $0.5I^2 r$; b. $0.5(I_1^2 + I_3^2)r$; c. $0.5(I_1^2 + I_3^2)r$;

$$d. rI_m^2/2T$$
; e. $rI_m^2/4$.

425a. 40 ft. per sec.; b. 66.2 ft.

427. $h_{av} = (\frac{1}{3})(h_2 + h_1 + \sqrt{h_2 h_1})$; $v_{av} = (v_2 + v_1)/2$.428. $T = (\pi r^2/Ac)(2h/g)^{1/2}$.429. $\zeta_{mean} = \alpha + (\beta/2)(T_2 + T_1) + (\gamma/3)(T_2^2 + T_2 T_1 + T_1^2)$.430. $B_{x,av} = \frac{2NIu}{r_2 - r_1} \ln \left(\frac{r_2}{r_1}\right)$.431. $V_{mean} = (\pi/6)d_{av}^3 = (\pi/24)(D + d)(D^2 + d^2)$; $d_{av} = 0.0403$ mm.432. $n = 1$: $p_{av} = \frac{k}{v_2 - v_1} \ln \left(\frac{v_2}{v_1}\right)$;

$$n \neq 1: p_{av} = \frac{k}{(v_2 - v_1)(n - 1)} (v_1^{1-n} - v_2^{1-n}).$$

433b. 0.014 per cent; 1.62 per cent.

434a. 0.0785 in.; b. $s = 75,000$ lb. per sq. in. and $F = (s)(\text{area}) = 37,500$ lb.

435(a) 0.0785 in.; (b) 0.0851 in.; (c) 0.0634 in.

436. (a) 2.74 ft.; (b) 2.74 ft.; (c) 2.82 ft.; (d) 3.16 ft.; (e) 2.80 ft.

437. 87.0 lb.; 79.5 lb.

438. $s_{ADB} = 81.4$ ft., $s_{ACB} = 65.9$ ft.439. $kL^2/2$.

440. 100.425 ft.

441. $100 + 0.4267 - 0.0016$.

442. 81.5 sq. in.

443. 20 cu. ft.

444. 0.43 cu. ft.

445. 83.0 cu. yd.

446. $S = 59.7a^2 = 14.9b^2$.

447. 6 by 8.33 in.

448a. $\frac{4\sqrt{2}}{3\pi} \frac{R^3 - r^3}{R^2 - r^2}$; b. $\frac{4\sqrt{2}}{3\pi} R$; c. $\frac{2\sqrt{2}}{\pi} R$.449. Fig. 128: $(2l/3, h/3)$; Fig. 129: $(3b/5, 3\sqrt{ab}/5)$.451a. $(w/2, h/2)$, $R_{x,2} = h\sqrt{3}$, $R_{y,2} = w\sqrt{3}$;

$$b. R_{x,3} = h/\sqrt[3]{4}, R_{y,3} = w/\sqrt[3]{4}.$$

452. $P = w^2 h^2/4$.

454a. $2T^2$; b. $2T^3/3$; c. $T^2/2 + T^3/12$; d. $10T^3/3 - T^4/12$.

455a. $\pi kLR^4\omega^2/4g$ ft.-lb.;

b. $r = 0.707R$ = radius of gyration with respect to the geometrical axis of the disk.

456a. 0.293 slug; b. 4.98 ft.-lb.; c. 5.00 ft.-lb.; d. 5.78 ft.-lb.

457. 47.5 radians per second per second. 461. $bd^3/24$, approximately.

462. 145,000 lb.

463. 22,100 lb.

464a. 3,120 lb.; b. 3,260 lb.; c. 4,520 lb. at 46.3° with horizontal.

465. 7,200 ft.-lb.

466. 10,400 ft.-lb.

468. 2,330 ft.-lb.

470. 3,550 ft.-lb.

472. $M_f = \frac{2\mu W}{3} \frac{r_2^3 - r_1^3}{r_2^2 - r_1^2} - \frac{2\mu W r_2}{3}$, $\mu W r_2$. 473. 4.41 B.t.u.

474. $Q = \frac{2\pi k(T_0 - T_1)}{\ln(r/R)}$.

477. $W = 4\pi I$.

478. $q = 2\pi \int_0^a r f(r) dr$.

479a. $q = \frac{5\pi}{6} V_m a^2$; b. $q = \pi V_m a^2$.

480. $w = \frac{b}{64N} \left(4c^4 \ln \frac{c}{a} + 4a^2 c^2 - 3c^4 \right)$.

481. $w = \frac{P}{32\pi N} \left(6c^2 \ln \frac{c}{a} + 2a^2 - c^2 \right)$.

483a. $L = a \left(1 + \frac{8f^2}{3a^2} - \frac{32f^4}{5a^4} + \dots \right)$; b. $32f^4/a^3$.

484. Error term is $(1/8) \int_{x_1}^{x_2} (dy/dx)^4 dx$.

486. Error term is $(ER^2 t^3/6L^3)$.

487. $t = 0.136$ sec.

488. $P = 0.0797$.

489. 0.92690.

491. $m = (1/3)(h/2R)^2 + (1/5)(h/2R)^4 + (1/7)(h/2R)^6 + \dots$;

$M = \frac{h^2}{R} \left\{ 1 + \frac{h^2}{12} \left(\frac{1}{R^2} - \frac{1}{h^2} \right) + \frac{h^4}{80} \left(\frac{1}{R^4} - \frac{2}{R^2 h^2} - \frac{2}{h^4} \right) + \dots \right\}$.

494. $L = (\pi/2)(D + d) + 2C + \theta(D - d) - C\theta^2$; error term is $+ C\theta^4/12$.

496. $E = \frac{1}{a} - \frac{1}{b} + \alpha \ln \left(\frac{b}{a} \right) + \sum_{n=2}^{\infty} \frac{\alpha^n (b^{n-1} - a^{n-1})}{(n-1)(n!)}$.

497. 24.5 miles.

498. 380 ft.

499. 8.7 in. per mile.

500. $H = 100 + 50g^2$, where $g = 0.05$.

501a. 6π ft.; b. 1,280 ft.; c. 0.0220 radian.

503a. $e_L = (Q/Ck)e^{-\alpha t} (k \cosh kt - \alpha \sinh kt)$; b. $q_L = Q$;

c. $e_C = (Q/Ck)e^{-\alpha t} (\alpha \sinh kt + k \cosh kt)$; e. $i = (Q/CLp)e^{-\alpha t} \sin pt$.

505. $E_s = 127,000 + j16,100$ volts.

506a. $\Gamma = \pm 1.76$;

b. $\Gamma = j(\pm 0.723 + 2n\pi)$, where n is a positive or negative integer;

c. $\Gamma = \pm 0.962 + jn\pi$.

- 507b. $E_s = 57,311 + 1,147(L - 200) + 11.5(L - 200)^2 + \dots$;
 $I_s = 57.35 + 1.15(L - 200) + 0.0115(L - 200)^2 + \dots$;
c. $f(L) = -17 + 0.42(L - 200) - 0.0115(L - 200)^2 + \dots$;
 $g(L) = -0.0175 - 0.0012(L - 200) + 0.000,004(L - 200)^2 + \dots$.
508. $c = 33.8$, $f = 26.5$.
- 509a. $84^\circ 55'$; b. 801.1 ft.; c. 98 ft.; d. 18 ft.;
e. $y = 80 + x^2/9,000$, error less than 0.02 ft.
510. $\theta = 56^\circ 28'$.