

ELEMENTARY ELECTRO-TECHNICAL SERIES

ELECTRIC ARC LIGHTING

BY

EDWIN J. HOUSTON, PH. D.

AND

A. E. KENNELLY, Sc. D.

SECOND EDITION, ENLARGED

12966

NEW YORK
ELECTRICAL WORLD AND ENGINEER



COPYRIGHT, 1902, BY

ELECTRICAL WORLD AND ENGINEER.

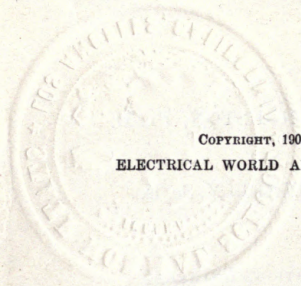

TK
4311
H81

PREFACE.

THIS little volume, like the others in the *Electro-Technical Series*, is written in language such as will enable the general public readily to understand the leading principles underlying the art of electric arc lighting, without any special training in electro-technics.

The rapid growth of out-door illumination by means of the arc light has rendered it a matter of necessity that the public should be able to possess a more extended knowledge of the principles underlying the production of the voltaic arc than can be obtained from the daily newspapers.

It is with the view of placing this knowledge in an accessible form, that the authors present this little book to the general reader.

A brief account is given of the early history of arc lighting, of the manufacture of arc-light carbons, and the mechanisms both for single and double-carbon lamps. Especial attention has been devoted to the physics of the carbon voltaic arc, the results of the most recent researches in this important branch of electric science having been carefully considered.

Not only has the detailed structure of the lamp mechanism been treated of, but also the various accessories connected with the commercial installation of the lamps in circuit have been fully considered.

The difficult subject of the amount of light emitted by the arc lamp, and the most satisfactory methods of estimating

the same have been considered on account of the importance they possess in the commercial sale of light.

The authors trust that this little book will prove of benefit to the general public.

PREFACE TO THE SECOND EDITION.

IN preparing the second edition of this little volume, the authors have added four chapters which cover the main developments of the last five years in this branch of electro-technics. It is believed that this will practically bring the work up to date.

CONTENTS.

CHAPTER	PAGE
I. EARLY HISTORY OF ARC LIGHTING, .	1
II. THE VOLTAIC ARC,	16
III. ELEMENTARY ELECTRICAL PRIN- CIPLES,	37
IV. ARC LAMP MECHANISMS, . . .	56
V. SERIES-CONNECTED ALL-NIGHT LAMPS,	117
VI. CONSTANT-POTENTIAL LAMPS, . .	137
VII. APPURTENANCES AND MECHANICAL DETAILS OF ARC LAMPS, . . .	163
VIII. ALTERNATING-CURRENT ARC LAMPS,	209
IX. LIGHT AND ILLUMINATION, . .	237
X. PROJECTOR ARC LAMPS,	268
XI. ARC LIGHT CARBONS,	307
XII. DYNAMOS,	323

CHAPTER	PAGE
XIII. ENCLOSED ARC LAMPS,	356
XIV. SERIES ALTERNATING ARC-LIGHT- ING FROM CONSTANT-CURRENT TRANSFORMERS,	375
XV. MULTI-CIRCUIT ARC-LIGHT GENER- ATORS,	393
XVI. PHOTOGRAPHY BY THE ARC-LIGHT,	397
INDEX,	407

ELECTRIC ARC LIGHTING.

CHAPTER I.

EARLY HISTORY OF ARC LIGHTING.

12966

UNFORTUNATELY for our planet, so far as its illumination at night is concerned, it has but a single moon, and this, on an average, is with us, on our hemisphere, but half of the nights throughout the year, so that half of our nights are necessarily devoid of moonlight. During full moon, when the sky is clear, the amount of light our earth receives from the moon is sufficient for all ordinary purposes of outdoor lighting, although, as we shall hereafter see, its

4
9-0-6
c

light is only about the 1-500,000th part of full sunlight.

Were we as favored as some of our sister planets as regards the number of moons, the problem of artificial outdoor lighting, during clear weather, would never have arisen. Had we, for example, the five moons of Jupiter, and did each of these afford as much light as our own moon, the intervals of no moonlight in fine weather would only occur about once a year. But even under these favorable circumstances, we would be dependent for our outdoor lighting on fair weather, so that the problem of outdoor lighting would still present itself.

Until the introduction of gas there were practically no means devised for outdoor lighting over extended areas, such,

for example, as the streets of a large city. It is true that candles and oil lamps afforded a meagre lighting in mediæval times, but the necessity for the night watchman to carry a lantern with him in his rounds always existed.

In recent times, the electric arc lamp has almost completely supplanted gas for the outdoor illumination in our large cities. The reason for this is to be found in its great power; *i. e.*, the large quantity of light which a single lamp is capable of producing as compared with a single gas burner, even when of large dimensions.

Artificial illumination by means of arc lamps is by no means an invention of the last decade. The brilliant light emitted by the carbon voltaic arc was known shortly after the invention by Volta of the

voltaic pile in 1796. The credit of this discovery has been erroneously assigned to Sir Humphrey Davy, and its date fixed by some at 1813. Before this date; *i. e.*, in 1809, Davy, by means of a powerful voltaic pile, first exhibited, on an extended scale, at the Royal Institution in London, the splendors of the voltaic arc; but, as he himself acknowledged, the credit of its discovery did not lie with him. Indeed, a little reflection will show that this must necessarily have been the case, since large voltaic batteries were employed before this date, and the mere opening of the circuit of one of these batteries must necessarily have been attended by the production of an arc. The intense brilliancy of the voltaic arc must have convinced many of those who first saw it, that in this agency the world possessed an admirable means for artificial illumination, and it is

not surprising, therefore, that many and various devices were produced, at an early date, for its employment.

* As is well known, when carbon electrodes, placed in a circuit carrying a powerful electric current, are slightly separated, a carbon voltaic arc is formed between them. During the maintenance of this arc the carbons are gradually consumed so that the space which separates them gradually increases, and a necessity thus arises for occasionally bringing the carbons nearer together. The early *arc-light regulators* employed for this purpose effected this regulation by hand; that is, when the operator deemed that the distance was excessive, he approached one of the carbons towards the other by some suitable hand adjustment. Subsequently, *automatic arc-light regulators* were introduced. These

early attempts at practical arc lighting were continued for many years after the first demonstration of the possibility of the carbon arc light, but it gradually became evident, that in the only source of electricity the world then possessed; namely, the voltaic battery, arc lighting was impracticable, except on an experimental scale, owing to the expense.

The invention by Bunsen about the year 1840 of his modification of Grove's voltaic cell marks another era in the history of arc lighting. Bunsen's type of voltaic cell employed two fluids, or was a *double-fluid cell*, and was a marked improvement on the voltaic cells previously existing, since it was not only able to furnish powerful currents, but could also furnish them steadily, a respect in which earlier voltaic cells had signally failed.

Two distinct improvements in the lamp mechanism characterize this era in the history of arc lighting; namely, improvements in the character of the carbon electrodes employed, and improvements in the nature of the regulating devices. Bunsen employed for the negative element of his voltaic cell, rods or plates of artificial carbon, which he formed from pastes made of mixtures of carbonaceous powders with some carbonizable liquid and subsequently carbonized the mixture, while out of contact with the air. Inventors were not slow to recognize the applicability of this invention to the production of the carbon rods or pencils required for arc lamps, and many improvements were made on Bunsen's process, as we shall describe in the chapter on arc-light carbons. But the improvements made during this epoch in the regulators were not of less importance

than those in the nature of the arc-light carbons, and many forms of lamp mechanisms appeared, capable of automatically maintaining a fairly steady light for several consecutive hours. Some of the pioneer inventors in arc-lamp mechanisms belonging to this period, are, Wright, Staite, Le Molt, Foucault, Serrin and Harrison, whose inventions were recorded between 1845 and 1857.

Times, however, were not yet ripe for the commercial introduction of arc lighting. Although the Bunsen battery was a great improvement over other forms of batteries, yet it was not capable of producing electric current with sufficient readiness and cheapness. It was troublesome to manage, and expensive to maintain. In the face of these difficulties all improvements in the lamp and its mechanism proved futile, and another period of inaction supervened.

The essential requirement for the production of a practical arc lamp was a cheap and effective generator. Like other great inventions, this was the product of several independent workers.

The germ of the invention had its birth in Faraday's discovery of a means for producing electricity by the aid of magnetism. Many early forms of *magneto-electric generators* were invented. Van Malderen's modification of Nollet's generator, which was employed as early as 1863 for the illumination of the light houses at Havre and Odessa, was, perhaps, the best fairly commercial machine then produced. Even this machine did not fully meet the requirements of every-day practice, and it was not until the invention by Gramme of what may, perhaps, be regarded as the first thoroughly commercial form of mag-

neto-generator, that the next marked era in electric arc lighting began. The world was thus given a means for the ready, reliable and cheap production of electric current, from a generator driven by a steam engine, or other source of mechanical power, and there again began a revival of arc lighting invention. This third period or epoch, has extended uninterruptedly to the present day, receiving, however, a great stimulus about 1876, when Jablochhoff produced his simple and then fairly efficient form of arc-light candle.

The necessity for more or less elaborate feeding mechanism in arc lamps, for the purpose of maintaining approximately constant the distance between the electrodes, despite their consumption in use, formed in the opinion of some, an insuperable obstacle to the extensive commercial

use of the arc light. As we well know actual practice has shown this fear to be groundless. In Jablochkoff's simple form of arc lamp, the carbons were maintained at a constant distance apart by a device which dispensed with regulating mechanism. * Jablochkoff's arc lamp or *candle*, as it was generally called, was based on the method of maintaining the carbons at a constant distance apart by placing them parallel to each other, and insulating them from each other by a block of kaolin, or some other non-conducting material. As the arc was formed, this material was volatilized and the arc was maintained between the carbons. It was believed that this simple device solved the much desired problem of a cheap and reliable regulating mechanism for the arc lamp.

When Jablochhoff's candle was put to the test of actual commercial use, it failed in a number of respects. At first the system employed continuous currents. Under these circumstances it is evident that, since the rate of consumption of the positive carbon is practically twice that of the negative, although at the start, when the arc was formed at their extremities, the two carbons would be in the same horizontal plane, yet, after burning for some time, the positive carbon would have been consumed to a distance much lower down than the negative carbon, thus leaving a greater separation between the two carbons than the thickness of the separating material and thus finally resulting in the extinguishment of the arc.

Fig. 1, shows a form of *Jablochhoff candle*. It consists of two carbons *A* and

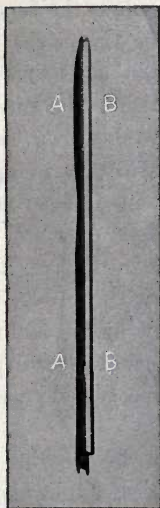

FIG. 1.—JABLOCHKOFF CANDLE.

B, cemented together by a mass of kaolin, which not only insulates them from each other but separates them the required dis-

tance. Inasmuch as the separated carbons cannot, as in the case of the ordinary lamp mechanism, be brought together and afterward separated for the purpose of establishing the arc between them, a device called an *igniter* was employed. This consisted of a mass of carbonaceous material which bridged over and separated the arc. After extinction of the candle, it would, of course, be impossible to relight it without a new bridge, and for this reason a number of candles were placed on the same lamp support inside a common globe.

With a view to avoiding some of the above difficulties, Jablochhoff employed alternating currents for his candles, thus ensuring a uniform consumption. Although this greatly improved the operation of the apparatus, and this method of illumination was employed commercially, yet on account

of its expense and for other reasons, it was soon replaced by improved devices.

Since the inventions of this epoch practically embrace the balance of the subject of arc lighting, they will be considered in detail throughout the book.

CHAPTER II.

THE VOLTAIC ARC.

As already mentioned, some doubt exists as to when the voltaic arc was first observed, but it would seem that this phenomenon must have been noticed coincidentally with the use of the first powerful voltaic battery.

When wires or other conductors connected with a powerful voltaic battery, or other electric source, are brought together and then slowly separated, the electric current does not immediately cease to flow; that is to say, provided the wires are not separated too widely, the circuit is not

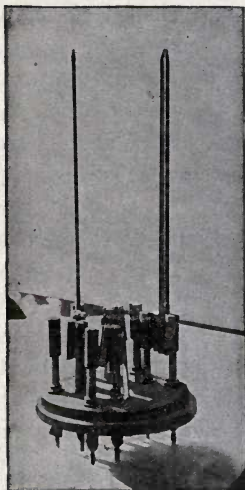

FIG. 2.—JABLOCHKOFF CANDLE HOLDER.

broken, but the space between them is traversed by a cloud of highly heated metallic vapor which carries the current. This incandescent cloud of vapor assumes

a bow or arc shaped form, which has received the name of the *electric* or *voltaiic arc*, after Volta, the inventor of the pile or battery, by the use of which the arc was first obtained. Such an arc, when formed between metallic substances, is called a *metallic arc*. The color of the light of metallic arcs varies with the metals forming the wires. In the case of copper the light is of a greenish hue. Nearly all metallic arcs possess a characteristic flaming. When the arc is produced between two carbon wires or rods, the *carbon arc* is formed, the color of which has a dazzling whiteness approaching that of sunlight.

It is assumed, for convenience, that in the electric circuit the current flows in a definite direction; namely, from the positive pole of the source through the circuit to the negative pole. When the circuit is

interrupted and an arc is formed at the gap, the current is assumed to flow from the positive carbon rod or electrode, across the intervening space, and to enter the negative rod or electrode, on its way to the negative pole of the source.

If, for example, the two carbon electrodes shown in Fig. 3, are connected with

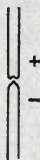

FIG. 3.—CARBON ELECTRODES.

the terminals of a sufficiently powerful electric source, and, after being brought into contact, are gradually separated to a distance of about $1/8$ th of an inch, the direction of the current being such that

the electric stream leaves the upper electrode, passes through the arc and enters the lower electrode, then the upper electrode will be the positive, and the lower, the negative, electrode. The positive electrode is generally indicated, as shown in the figure, by a + sign, and the negative electrode by a - sign.

The carbon voltaic arc is too brilliant to be observed directly by the eye, but if it be examined through smoked or densely colored glass, the following characteristics may be observed :

In the space or gap between the opposed carbons an arc or bow-shaped bluish flame appears, much less brilliant than the ends of the carbon electrodes. If the arc has been maintained for a little while, the ends of the carbons will be observed, as shown in Fig. 4, to differ markedly in



FIG. 4.—CARBON VOLTAIC ARC.

shape, the end of the positive electrode being hollowed out in a small *crater* or cup-shaped form; while the opposed surface of the negative electrode will be seen to have

a minute projection or *nipple* formed on that part of its surface directly opposite the crater. It will be evident too, that while the ends of the carbon electrodes are brighter than the mass of the arc proper; *i. e.*, of the arc-shaped flame between them, that they are by no means of equal brilliancy, the positive carbon being much brighter than the negative. Moreover, it will be seen that all parts of the end of the positive carbon are by no means equally bright, but that most of the light issues from the crater. Since the light giving power of a heated body increases rapidly with its temperature, a mere inspection of the arc will show that the crater in the positive carbon is the hottest part of the arc.

When the current is powerful, a duller incandescence can be observed, accom-

panied by a bluish, lambent flame, over the ends of the carbon electrodes, for distances varying from $1/2$ to $3/4$ ths of an inch. This flame is of similar origin to that which may be observed over the surface of a hard coal fire when insufficiently supplied with air, and is due to the burning of the carbon vapor in the oxygen of the surrounding air. It is well known, that carbon may undergo chemically two distinct forms of oxidation; namely, first, incomplete oxidation, producing what is called carbon monoxide, characterized by the blue flame of the coal fire already referred to, and second, a more complete oxidation producing what is called carbon dioxide or carbonic acid. It is believed that in the interior of the arc no oxidation of carbon vapor occurs, not only because the vapor fills this interior space, and, therefore, displaces the air, but also be-

cause the temperature of the disengaged vapor is so high that it is above that at which carbon monoxide can exist without *dissociation*, or separation into carbon and oxygen. Even a casual inspection of the ends of the electrodes will show that, with the current strength ordinarily employed, the incandescence extends to a comparatively short distance from the tips. This is the region in which the burning or oxidation of the carbon is most marked, and after the arc has been maintained for a while under the double influence of volatilization and oxidation, the ends of the electrodes assume a more or less irregular shape as represented in Fig. 4.

Confining our attention to the conical shaped ends of the carbons, minute globules of molten matter will be seen scattered here and there over their sur-

faces. These globules are probably molten drops of various mineral impurities in the carbon, and the more nearly pure the carbons, the fewer they will be. It will soon become evident, on continuing an examination of the arc, that the crater does not maintain its position, but shifts, at irregular intervals, from point to point on the surface of the positive electrode. The cause of this shifting is to be found in the fact that as the carbon is consumed by volatilization and oxidation, the edge of the crater becomes unequally worn at different parts, and the arc tends to be established at the point where the distance is the least, thus temporarily determining the new position of the crater. So, too, should slight impurities or irregularities in the quality of the positive carbon exist, they will determine a different rate of volatilization, the portions which volatilize

most readily at any given time, tending to become the centre of the crater.

This shifting of the position of the crater, and consequently of the arc, is objectionable from the fact that it leads to an *unsteadiness* or *flickering* of the light and a consequent variation in the distribution of the light over the surrounding space. When, therefore, the flickering is frequent and marked, the effectiveness of the illumination suffers. Various expedients have been adopted in order to reduce this shifting of the arc to a minimum. Among the most important of these are the reduction of the diameter of the carbon, so as to afford a smaller area over which the arc can shift, and providing the centres of the electrodes with a softer carbon, so as to insure the greatest liberation of carbon vapor from the central por-

tions and the consequent formation of the arc at these parts. Such carbons are called *cored carbons*.

If a vessel of water is placed on a fire, or other source of heat, and heated under circumstances in which its vapor is permitted readily to escape into the air, the temperature of the water can never, at ordinary atmospheric pressures at the level of the sea, be raised above that of its boiling point; namely, 212° F. or 100° C. Under these conditions the temperature of the boiling point of water is the temperature of its volatilization. This is a general law for the volatilization of all substances; namely, if the vapor which is formed during volatilization is free to escape, the temperature of the liquid will remain constant during its ebullition or volatilization. An increase in the tempera-

ture of the source, has the effect only of accelerating the volatilization and increasing the rate of the formation of vapor. In the same way it is believed that the temperature of the positive carbon or crater in the arc lamp is thus limited to the temperature of the boiling or volatilization of carbon under atmospheric pressures. An increase in the *current strength*; *i. e.*, in the quantity of electricity which passes per second through the arc, is observed to have no effect upon the temperature of the arc, but only to increase the amount of carbon volatilized, and, consequently, to be followed by an increase in the area of the crater. The temperature of boiling carbon and consequently the temperature of the positive crater has been estimated at $3,500^{\circ}$ C. This temperature is the highest we have yet been able to produce artificially, and, in accordance with preceding

principles, we have no apparent means of increasing it unless we can obtain conditions under which the boiling point of carbon is increased. It would seem by analogy that an increase of pressure should increase this temperature of volatilization, but so far as actual experiments go, such an increase has not been obtained.

The following are the melting points of some of the more refractory metals according to recent measurements:

Iridium,	1,950° C.
Platinum,	1,775°
Iron,	1,600°
Palladium,	1,500°
Nickel,	1,450°
Cast Steel,	1,370°
Pig Iron,	1,075°
Copper,	1,054°
Gold,	1,045°
Silver,	954°
Aluminum,	600°

The temperature at which bodies begin to become luminous is about 500° C.

It is evident that since the temperature of boiling carbon is so much higher than any of the above melting points, the use of any of these substances for arc light electrodes is not likely to be attended with favorable results, for it is well known that the luminous intensity of a source increases rapidly with its temperature.

The temperature of the arc proper; *i. e.*, the stream of carbon vapor emerging from the crater, is probably nearly as great as that of the crater itself, at least within the vicinity of the positive electrode. Near the negative electrode, the temperature falls, the temperature of the negative electrode being less than that of the positive electrode.

It is well known that when the vapor which is formed from a boiling liquid is cooled below a certain temperature, it condenses or again passes into the liquid or even into the solid state. This is also true in the case of the voltaic arc; for, while the temperature of the negative carbon is very high, yet it is below the condensation point of carbon vapor; that is to say, the carbon electrode, although white hot, is, nevertheless, sufficiently cool to chill the carbon vapor, which deposits or condenses on the negative electrode in the form of the hillock or nipple already referred to. Only some of the carbon vapor is condensed on the negative electrode; the greater part, approximately three fourths, is diffused outwards from the heated surfaces until at its outer edge it becomes oxidized by combination with the oxygen of the air, forming a blue flame which hangs

like a mantle around the outer surface of the arc.

It is not generally known that the characteristic bow or arc shape of the mass of carbon vapor in the voltaic arc is a phenomenon of a magnetic character. An electric current is never established without the simultaneous formation of a magnetic field, and when a movable conductor is brought in a magnetic field, the effect of the field on the conductor is to cause a motion of the conductor in a direction dependent upon the polarity of the field. Since the carbon vapor of the arc is readily movable, its arc or bow shape is the effect produced by the magnetic field of which it is the cause. The characteristic or bow shape of the arc is, therefore, fixed and determined under the conditions by which it is produced.

The voltaic arc furnishes the most intense source of artificial heat known, even the most refractory substances being softened and all the metals melted when brought within its influence. Platinum placed within it melts like wax in the flame of a candle. The high temperature of the voltaic arc has been employed in the arts for the production of various forms of *electric furnaces* and *electric crucibles*, in which not only fusions are accomplished, but also various metallurgical processes are successfully carried on. The heat of the voltaic arc is also employed to obtain readily welding temperatures for welding various metallic substances.

The artificial carbon electrodes employed in arc lighting are exceedingly hard and will not leave a mark when rubbed on paper. After they have been employed

for a short time in the establishment of an arc between them, it will be found that the extremities of both carbons, but particularly the nipple on the negative carbon, has been converted into a variety of soft carbon called *graphite*, the material employed in lead pencils. This experiment can be tried with specimens of carbon taken from any arc lamp, when it will be found that the tip of the negative carbon will serve for quite a little time in place of a lead pencil.

The voltaic carbon arc, which we have thus far described, has been obtained by the use of the *continuous electric current*, that is, an electric current which continually flows in the same direction. Voltaic arcs may also be formed by *alternating currents*; or currents which flow alternately in opposite directions. When alternating

currents are employed, the characteristic crater and nipple do not form, since each carbon is alternately positive and negative.

During the establishment of the carbon voltaic arc, the electrodes are consumed or gradually waste away. This waste is due to the gradual burning or oxidation in the air, as well as to the volatilization of the positive carbon. Since the positive carbon is consumed both by burning and by volatilization, its rate of consumption is necessarily greater than that of the negative carbon, it being consumed approximately about twice as rapidly.

The formation of the carbon voltaic arc may take place almost noiselessly or it may be accompanied by various sounds. When the carbons are nearly pure, are continuously separated at the proper distance for

steady burning, and are supplied with a uniform current strength, the maintenance of the arc is unattended by sensible noise. If, however, these conditions are not complied with, various hissing sounds are developed. A characteristic hissing is apt to occur when the distance between the carbons is too small; it also occurs when the current strength is too great.

CHAPTER III.

ELEMENTARY ELECTRICAL PRINCIPLES.

BEFORE proceeding to a description of the detailed apparatus employed in arc lamps, it will be necessary to consider some of the elementary electric principles involved in their operation. An electric current can never be established through conducting substances unless a continuous path or *circuit* is provided, by which it may pass out from or leave the electric source and return thereto after having passed through the circuit, and such translating devices as may be placed therein. All electric sources, therefore, possess two points called *poles*, from one of which, the *positive* pole,

the current emerges, and at the other of which, the *negative* pole, it re-enters. *Electric sources*, such, for example, as voltaic batteries, dynamo-electric machines or thermo-electric piles, are sometimes spoken of as producing electricity. What they really produce is a variety of force, called *electromotive force*, generally abbreviated E. M. F., which possesses the power of setting electricity in motion. In other words, an electric source is a device whereby mechanical, chemical or thermal force may be transformed into electromotive force.

The action of an electromotive force on a circuit bears an analogy to the action of pressure on a liquid mass. If, for example, a pipe filled with water be bent into a circuit, that is, connected so as to form an endless path, the water it contains

cannot be set in motion, unless pressure be brought to bear upon some part of its mass. As soon as this is done, motion, *i. e.*, a *water current*, will take place in the liquid, the direction of which is always from the position of greatest, to the position of least pressure. Such a force tending to cause water to flow in the circuit of a pipe might be called a *watermotive force*. Similarly, in an electrically conducting circuit, it is the E. M. F. which causes the electricity to flow. In this sense the E. M. F. may, by analogy, be regarded as a pressure, the electric current being assumed to flow through the circuit from the point of greatest to the point of least pressure. It must be remembered, however, that such ideas are only useful as analogies, since we do not in reality, as yet, know exactly what electricity or electromotive force may be.

In the case of a *hydraulic circuit*, as in Fig. 5, consisting of a closed pipe *ABC*, and means, such as a pump *P*, for producing watermotive force, the *quantity of liquid*

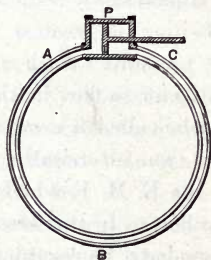

FIG. 5.—HYDRAULIC CIRCUIT.

which can flow per second past any cross-section of the pipe, under a given watermotive force; that is, the current of water which passes, will depend on the area of cross-section of the pipe, the length of the pipe, and the nature of the material of

which it is made. In other words, the pipe offers a certain resistance to the flow of water through it under the impulse of the watermotive force developed by the pump.

Similarly in an electric circuit, consisting of a closed path and means, such as an electric source, for producing electromotive force, the *quantity of electricity* which can flow per second under a given E. M. F. through any part of the circuit, will depend upon the area of cross-section of the conductor, or wire, the length of the wire, and on the nature of the materials of which it is made. In other words, a conducting circuit offers a certain resistance to the passage of electricity through it, just as a conducting pipe does to the passage of water through it. The *electric resistance* of a conductor is measured in *units of elec-*

tric resistance called *ohms*, the ohm being, approximately, the resistance offered by a mile of No. 3 A. W. G. (American Wire Gauge) wire, nearly a quarter of an inch in diameter. The resistance of the wire or circuit increases directly with its length; thus, two miles of No. 3 wire would offer two ohms resistance, and 100 miles, 100 ohms resistance. The resistance of a wire or circuit diminishes with the cross-section of the wire; *i. e.*, increases inversely as the cross-sectional area. Thus, if we double the cross-section of the wire, we halve its resistance in the same length. For example, a mile of wire having twice the area of No. 3 wire, would have a resistance of half an ohm per mile. Thus, No. 0, A. W. G. wire, the size of ordinary trolley wire, has about twice the cross-section of No. 3 wire, and, consequently, offers a resistance of about half an ohm per mile.

The resistance of a wire depends not only upon its area of cross-section, but also upon the nature of the material composing it. For example, a No. 3 A. W. G. iron wire, one mile long, would have a resistance of $6\frac{1}{2}$ ohms; or a resistance about $6\frac{1}{2}$ times as great as that of the same length and size of copper wire. In order, therefore, to compare the resistances of wires of different materials having the same dimensions, it is necessary to consider what is called their *resistivities*; *i. e.*, the resistance in a wire of unit length and area of cross-section. Thus the resistivity of pure copper, at the temperature of melting ice, is generally taken to be 1.594 millionths of an ohm; that is to say, a wire of this pure copper, one centimetre long and one square centimetre in cross-sectional area, would offer a resistance of 1.594 *microhms*, or millionths of an ohm, and a

mile of such wire (160,933 centimetres) having the same cross-section, of one square centimetre, would have a resistance of $\frac{160,933 \times 1.594}{1,000,000} = 0.2565$ ohm.

The resistance of a wire or circuit is a very important quantity and constantly enters into electrical determinations. As examples of a few resistances of well-known apparatus we may take the following:

The ordinary Bell telephone has a resistance of about 75 ohms.

An ordinary 16-candle-power incandescent lamp has a resistance of about 250 ohms, when hot.

The resistance of a mile of ordinary iron telegraph wire is about 13 ohms.

Electromotive forces are measured in *units of electromotive force* called *volts*.

All electric sources produce electromotive forces, and it is these E. M. Fs., acting on a conducting circuit, which cause electricity to flow through the circuit. A well-known electric source, called the *blue-stone voltaic cell*, produces an E. M. F. of approximately one volt. When it is desired to obtain a higher E. M. F. from blue-stone cells, it is necessary to connect a number of separate cells in series, so as to permit them to act as a single source. Such a combination is called a *voltaic battery*. A *dynamo-electric machine* is another source employed for producing E. M. Fs., the value of which depends, in any given machine, among other things, upon the rate of rotation of the armature. Dynamo-electric machines for the proper operation of incandescent lamps, produce E. M. Fs. of about 120 volts; those for operating arc lamps, may produce E. M. Fs. varying from 50 to 10,000 volts, according

to the number of lamps placed in the same circuit, each ordinary arc lamp requiring, approximately, 50 volts to maintain it. *Railway generators*, required to operate railway systems, are designed to supply an E. M. F. of about 500 volts, between the trolley and the track wire.

The most important consideration respecting an electric circuit, is the *quantity of electricity per second*, or the *current*, which passes through it; or, in other words, the rate at which electricity is caused to flow through the circuit. The quantity of electricity which flows through any circuit is measured in *units of electric current* called *amperes*. In the case of the electric circuit, as in the case of the hydraulic circuit, the rate of the flow is conveniently measured as the quantity per second; thus we may speak of a gallon per second. So

in the electric circuit, the rate of flow or current is conveniently referred to a certain quantity per second. The *unit of electric quantity* is the *coulomb*, and is such a quantity as will produce, when passing in one second, a unit current or rate of flow, or, one ampere. Or, in other words, if one coulomb of electricity passes through an electric circuit in a second of time, it will produce a rate of flow which can be correctly expressed as one ampere. An ordinary 16-candle-power incandescent lamp requires, usually, a current of about half an ampere to maintain it. A 2,000 candle-power arc lamp of the ordinary outdoor type requires nearly 10 amperes. A street car motor when in operation, requires on an average about $12\frac{1}{2}$ amperes. A telegraphic relay requires about $\frac{1}{100}$ th of an ampere, or about 10 milliamperes.

In order to determine the value of the current which will pass in any given circuit under given conditions of E. M. F. and resistance, reference is had to a law, called *Ohm's law*, after the name of its discoverer. Ohm's law may be briefly stated as follows :

The current strength in any circuit is equal to the E. M. F. acting on that circuit, divided by the resistance of the circuit; or, briefly, the current which will flow in amperes, is equal to the E. M. F. expressed in volts, divided by the resistance expressed in ohms.

Suppose, for example, that an E. M. F. of 100 volts, acts on a circuit, the resistance of which is 50 ohms; then the current strength which will flow through the circuit under these conditions will be

$100 \div 50 = 2$ amperes, and this current will be maintained so long as the E. M. F. and resistance bear this ratio to each other.

When an electric current passes through a circuit, certain characteristic effects are produced in various apparatus, such as lamps or motors, placed in the circuit. In producing these effects, energy is expended or work is done, which energy is derived from the electric current, which in its turn derives it from the electric source. For example, when an electric motor is observed to raise a number of passengers in an elevator, the work which it has to do in order to lift them against gravitational force, is derived from the electric circuit which supplies the motor, and the circuit in its turn receives this power from the generator supplying the E. M. F., while the generator receives the same from the

engine, which drives it. The *amount of work* done in raising the elevator may be measured by the number of pounds weight in the loaded elevator, and the distance in feet through which the elevator is raised. For example, if the elevator with three passengers weighs 2,000 pounds, and if the distance through which it was lifted by the motor was 200 feet, the work done by the motor in raising the elevator would be $200 \times 2,000 = 400,000$ foot-pounds. A unit frequently employed for the *unit of work*, is called the *foot-pound*, and is the amount of work done in lifting one pound, through a vertical distance of one foot, against the earth's gravitational pull. The foot-pound is not, however, the unit of work that is generally employed in electrical measurements. For several reasons it is more convenient to employ a unit of work called the *joule*, which is, approximately, 0.738

foot-pound. One one-foot pound is, therefore, greater than a joule, being approximately 1.355 joules. Consequently, the amount of work expended by the motor on the elevator, in the case just alluded to, might be expressed as $400,000 \times 1.355 = 542,000$ joules.

When an E. M. F. acts upon a current in a circuit it always expends energy, on the current, or does work on it. In other words, an E. M. F. cannot drive a current through a circuit without the expenditure of energy, or without doing work.

In ordinary mechanical work, the amount of energy expended may be expressed, as we have seen, by the foot-pound, as being equal to a number of pounds raised through a certain number of feet. So in electric work, the amount of energy expended may

be expressed by the *volt-coulomb*, that is, by a certain number of coulombs passing through a circuit under a pressure of a certain number of volts. For example, if a circuit has acting in it an E. M. F. of 120 volts, and 100 coulombs of electricity pass through the circuit, either in a second, an hour, or a day, the total amount of work expended in this flow will be $120 \times 100 = 12,000$ volt-coulombs. The electrical units have been so chosen that a volt-coulomb is equal to the joule; so that in the preceding case the work done would be 12,000 joules $= 12,000 \times 0.738 = 8,856$ foot-pounds.

The *rate-of-doing-work* or of expending energy is called *activity*. The *unit of activity* generally employed in ordinary mechanical applications is the *foot-pound-per-second*, or, in larger units, the *horse-power*, which is 550 foot-pounds per second.

Thus, if the elevator previously mentioned was lifted through a total distance of 200 feet, in 40 seconds, the average rate of doing work in this time would have been

$$\frac{400,000}{40} = 10,000 \text{ foot-pounds-per-second.}$$

It is evident that, no matter how long the motor took to raise the elevator, the total amount of work done would be the same, whether the elevator were lifted in one second or in one minute, but the rate at which the work was done would vary very greatly, since, in the former case, the energy would have to be expended sixty times more rapidly than in the latter.

The *electrical unit of activity* is the *joule-per-second*, or the *volt-coulomb-per-second*. Since a coulomb-per-second is, as already stated, equal to one ampere, the electrical unit of activity is the *volt-ampere*; or, as

it is more frequently called, the *watt*. If then, we multiply the number of volts, which are acting on a circuit, by the number of amperes passing through it, the product will be the number of watts, representing the activity, or the rate-of-working in the circuit. For example, an ordinary outdoor arc lamp usually requires an E. M. F. of about 45 volts to be maintained at its terminals, and a current strength flowing through the lamp of 10 amperes. Under this pressure of 45 volts, the activity, or rate-of-doing-work, in the lamp is usually about $45 \times 10 = 450$ volt-amperes = 450 watts, and since 746 watts are equal to one horse-power, the average rate of working in an ordinary arc lamp is about $\frac{450}{746}$ ths horse-power; or, approximately, $\frac{3}{5}$ ths horse-power. Similarly, an ordinary incandescent lamp, operated from a 110-volt

circuit, usually requires a current of about half an ampere. The activity in such a lamp is, therefore, $110 \times 1/2 = 55$ watts, or about 55/746ths horse-power, or about 1/13th horse-power.

CHAPTER IV.

ARC LAMP MECHANISMS.

SINCE, during the establishment of the voltaic arc, the carbons are consumed at unequal rates, and the maintenance of the arc depends upon their preserving a proper distance from each other, it is evident that some form of mechanism is necessary, which shall automatically maintain this distance between them under all circumstances. In the early history of the arc, such mechanisms were controlled by hand, but it is needless to say that hand regulators have now been entirely replaced by *automatic regulators*.

There are two distinct classes of mechanism employed in arc lamps; namely, those which maintain constant the distance between the electrodes, but do not keep the position of the arc fixed, and those which not only keep the distance between the carbons fixed, but which also maintain fixed the position of the arc. In the first class of mechanisms but one carbon, usually the upper or positive carbon, is fed or moved; in the other class, both carbons are moved, and in this case, since the positive is consumed more rapidly than the negative, the relative motions of the two carbons must be different. To the first class of mechanism belongs the ordinary type of arc lamps employed for street lighting. To the second class belong various *projectors*, *search lights* or other apparatus employing reflectors or lenses. Here it is necessary that the arc

shall be maintained at the focus of the reflector or lens.

In any form of arc lamp, three conditions must be complied with, by the feeding mechanism, in order to insure continuous operation :

(1) It must bring the carbons initially into contact.

(2) It must then separate the carbons to a suitable distance and maintain this distance.

(3) It must cause or permit the carbons to approach when consumption has rendered their separating distance too great.

The carbon electrodes of arc lamps are placed in the lamp in various positions. Lamps have been employed in which the carbons are inclined, or placed horizontally or vertically as shown in Fig. 6, at *A*, *B*,

and *C*. The vertical position, however, is now almost invariably adopted, since it not only places the positive crater in the most effective position for throwing light downwards, but it also permits the approach of the positive towards the negative carbon

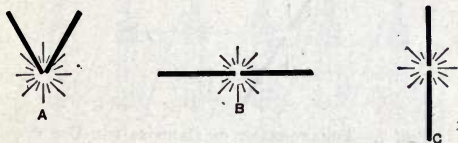

FIG. 6.—ARRANGEMENT OF ARC LIGHT CARBONS.

to be effected by the influence of gravity. As we shall see, however, in many forms of projectors, where it is desired that the most powerful beams shall be projected in a nearly horizontal direction, the carbons are inclined in the same straight line from the vertical as shown in Fig. 7.

Before proceeding to a description of the different forms of arc-lamp mechanisms, it will be necessary to describe in detail the various methods by which the lamps are connected with their generators.



FIG. 7.—ARRANGEMENT OF CARBONS FOR USE IN A PROJECTOR.

Although many forms of circuits for this purpose are in use, yet they can all be arranged in two classes; namely, the

- (1) *Series circuit.*
- (2) *Parallel circuit.*

In the series circuit of arc lamps, the current passes through each lamp in suc-

cession. A series connection of arc lamps is shown in Fig. 8, where six arc lamps are connected to the line in series. Here as will be seen, the current entering at the left hand or positive terminal of the lamp, passes through the lamp mechanism,

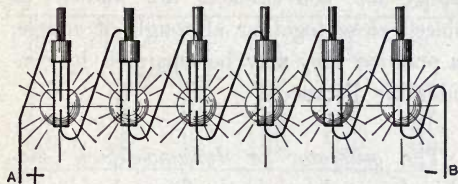

FIG. 8.—SERIES CONNECTION OF ARC LAMPS.

issues from the upper carbon, which is here the positive carbon, and leaves the lamp after having passed through the negative carbon, at its negative terminal. The negative carbon of the first lamp, is thus connected to the positive terminal of the second lamp, and its negative terminal

to the positive terminal of the third, and so on throughout the series. In other words, the current entering at the positive end of the line passes through each lamp in succession, leaving each lamp at its negative terminal. In the drawing, the lamps, for convenience, are shown as placed close together, although, of course, in practice, they may be separated by considerable distances.

The *generator* or *dynamo-electric machine* is not shown in the figure, but it will be understood that the two wires, *A* and *B*, are connected to the terminals of the dynamo which generates the current, so that the electric current leaving the dynamo and entering the circuit at the point *A*, passes successively through each of the lamps shown, again entering the dynamo at, say, the point *B*.

In the *parallel* or *multiple connection* of arc lamps, as shown in Fig. 9, all the positive terminals of the separate lamps are connected to a single *positive lead* or conductor, and all the negative terminals, to a single *negative lead* or conductor. Here it

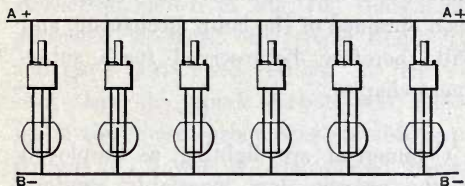

FIG. 9.—PARALLEL OR MULTIPLE CONNECTION OF ARC LAMPS.

will be seen that all the six lamps shown have the current entering at their positive terminals and passing out at their negative terminals. The current, as before, leaves the machine, enters the positive lead near the point marked *A*, and returns to the

machine after having passed through all the lamps in the circuit, at the point marked *B*.

The properties and peculiarities of the series and multiple circuit, will be better understood when a fuller knowledge has been obtained of the lamp mechanism, and will, therefore, be reserved for a subsequent chapter.

Commercial arc lighting, as employed at the present day, invariably employs considerably more than a single lamp in a dynamo circuit. In the early history of the arc, where but a single lamp was employed in connection with a single circuit, a much simpler form of feeding mechanism was compatible with fairly satisfactory uniformity in the intensity of the light furnished, and some of the earlier forms of

arc lamp mechanism consisted essentially of a single electromagnet placed in the main circuit.

One of such simple forms of early single-light lamps was the arc lamp of Archereau, shown in Fig. 10. This lamp possessed the merit of extreme simplicity and gave fairly good results. It will be seen that the upper carbon was fixed, while the lower carbon was suitably supported on a rod of iron placed inside a helix or coil of insulated wire called a *solenoid*, being balanced therein by a counterpoise or weight passing over a pulley, as shown. When no current was passing through the lamp, the weight raised the carbon and its supporting rod, and brought the end of the lower carbon into contact with the upper carbon. As soon as the current passed through the

circuit, the attraction of the solenoid on its iron core caused the solenoid to be

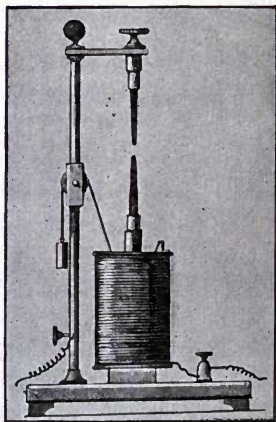

FIG. 10.—ARCHEREAU'S REGULATOR.

sucked into the core, with a consequent separation of the lower movable carbon from the upper carbon and the formation

of an arc between the two. When, during the maintenance of the arc, the carbons were gradually consumed and the distance between their free ends thus increased, the smaller current strength passing through the circuit, on account of the increase in its resistance, caused the solenoid to attract its core less powerfully, and permitted the weight to move the lower carbon toward the upper carbon. On the other hand, when this distance became too small, the increased current strength passing through the solenoid again caused the separation of the lower carbon from the upper. This lamp, despite its simplicity, gave fairly good results.

Other early forms of arc lamps were operated on a somewhat similar principle, and consisted of devices whereby an electromagnet, placed in the main circuit,

caused the separation of the carbons, which were always in contact when the current was not passing through the lamp. Most of these forms fed the upper carbon, the mechanism being such that the weakening of the current, consequent upon the formation of too long an arc, permitted the upper carbon to descend by gravity towards the lower carbon, while the strengthening of the current, following a decreased distance between the carbons, again insured a lifting of the upper carbon.

Lamps of a description somewhat similar to the preceding are still in use on multiple circuits, and some of these will be subsequently shown. A little consideration will show that a lamp with a single electromagnetic feeding device is not suitable for use in series-connected circuits, especially when, as is usually the case, a very great

number of lamps are placed in the same circuit.

Series-connected arc light circuits invariably employ two electromagnets, in the feeding and controlling mechanisms, principally for the reason that such a system permits the feeding of each lamp to depend entirely on its own requirements, and prevents it from being affected by every other lamp in the circuit. Suppose, for example, that one of the carbons of a single lamp should temporarily stick, or be unable to move towards the other carbon, thereby unduly increasing the size of its arc. This increase in the resistance of the circuit, will, of course, diminish the current strength in all the other lamps, and they will, in consequence, all regulate so as to feed their carbons too close, in an endeavor to restore the current strength. If, then,

the temporarily arrested lamp feeds suddenly, the current in the circuit will be much too strong, and there will be a rapid regulation in all the lamps, tending to separate the carbons. In this way, the lamps become unstable in their adjustments, and rapidly oscillate, or see-saw, pulling alternately long and short arcs, at the same time causing a marked travelling of the arc around the carbon, and a consequent flickering of the light. It is evidently necessary, therefore, to adopt some other expedient.

The great discovery, which rendered series arc lighting a possibility, was made as early as 1855, by Lacassagne and Thiers, who introduced into the arc lamp mechanism, an electric device known as a *derived circuit* or *shunt*. If more than a single path is open to an electric circuit,

when, for example, as in Fig. 11, a circuit branches through the two paths ACB and ADB , the proportion in which the current will divide through these two circuits will depend upon their relative conducting powers, and will be, therefore, inversely as

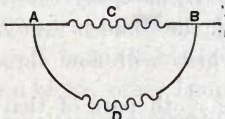

FIG. 11.—DERIVED OR SHUNT CIRCUIT.

their relative resistances. If the circuit ACB , originally existed alone, and the additional circuit ADB , were provided by connecting the conductor D , at the points A and D , then the latter would be called a derived or shunt circuit, and this portion of the conductor would be said to be placed "*in shunt*" with the conductor ACB .

If, in the case shown in Fig. 11, the resistance of the two circuits be equal, then half of the current would pass through each branch, or the current would divide equally, the current strength being the same in each branch. If, however, the branch ADB , have, say 100 times the resistance of the branch ACB , then the amount which will flow through ADB , will be the $\frac{1}{100}$ th part of that which will flow through ACB ; or, in other words, the greater the resistance of the path ADB , relative to the resistance of the path ACB , the smaller will be the proportion of the current which passes through it. If, in Fig. 11, the resistance ABD , is fixed in amount, and ACD , is variable, then these variations will automatically vary the current strength in ADB , as well as in ACB .

We have already pointed out the fact that series-connected arc lamps cannot be made to operate with the steadiness required for commercial purposes, when their mechanism contains but a single electromagnet, since, under these circumstances, the operation of the feeding mechanism is not only dependent on the requirements of the lamp itself, but is liable to be affected by the action of any other lamp in the circuit. A single faulty lamp thus possesses the power of producing unsteadiness in all the other lamps in the circuit. It is evident, therefore, that for commercial purposes, a successful lamp mechanism must be able to effect the regulation independently of the other lamps in the circuit. To give the arc lamp this power, a shunt or derived circuit is required. Since its introduction into the art by Lacassagne and Thiers, many modifications of the principle

have been made, but all the series arc lamps of to-day employ essentially this principle. It is, therefore, important to

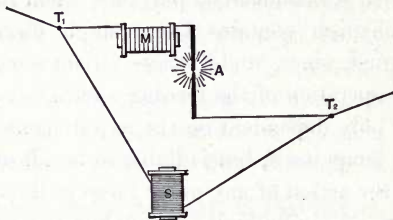

FIG. 12.—DIAGRAM OF SHUNTS AND SERIES MAGNETS.

- describe in detail the general plan of operation of such arc-lamp mechanism.

Fig. 12 represents, diagrammatically, the essential relations of a *shunt magnet* as utilized in an arc lamp mechanism. Here *A*, represents the voltaic arc established between the carbons, *M*, a magnet placed

in the direct circuit of the arc, and S , a shunt magnet, of fine wire and having a high resistance, placed in the derived or shunt circuit around the arc as shown. In accordance with the principles already explained in connection with shunt circuits and Fig. 11, it is evident, since the resistance of the magnet S , is large, that practically all the current passing through the lamp will traverse the arc.

The pressure existing between the main terminals T_1 and T_2 , expressed in volts, will depend upon two circumstances; namely,

- (1) The *counter E. M. F. of the arc* (*C. E. M. F.*); *i. e.*, an E. M. F. opposed or acting in the opposite direction to that which causes the current to pass through the arc.
- (2) The *drop of pressure or apparent C. E. M. F.*, due to the combined resistance of the carbons; the resistance of the arc

itself between carbons, and the resistance of the coils of the magnet M .

When a current is passed through a resistance under the action of an E. M. F., then in accordance with Ohm's law, the pressure at the terminals of the resistance, in volts, will be the product of the resistance in ohms and the current strength in amperes. If a pressure of 10 volts be maintained at the terminals of a resistance of 5 ohms, the current strength passing through the resistance will, by Ohm's law, be, $10 \text{ volts} \div 5 \text{ ohms} = 2 \text{ amperes}$; or, we may regard the product of $5 \text{ ohms} \times 2 \text{ amperes} = 10 \text{ volts}$, as being the *drop of pressure*, which necessarily attends the passage of the current through the resistance.

Of the resistance in the main arc circuit; namely, the carbons, direct magnet,

and arc proper, the values of the two former, assuming a fixed temperature and length of carbons, are fixed, while the resistance of the arc itself varies with its length, and area of cross-section, the longer the arc and the smaller the area of cross-section, the greater its resistance. The resistance of the arc carbons may be about $\frac{3}{10}$ ths of an ohm, so that a current of 10 amperes, passing through the carbons, would produce a drop of $10 \times \frac{3}{10}$ ths or 3 volts; *i. e.*, 3 volts would have to be maintained on these carbons in order to keep the current of 10 amperes flowing through them. Similarly, the resistance of the direct magnet M , may be about $\frac{1}{10}$ th of an ohm, and the drop in this resistance will be 1 volt; for, 10 am-

peres \times 1/10th ohm = 1 volt. The resistance of the arc is, roughly, 5 ohms per inch, so that an arc of 1/8th inch in length, a very common length, has a resistance of about 5/8th ohm, and the drop in this resistance, at a current of 10 amperes, will be $10 \times 5/8 = 6 \frac{1}{4}$ volts. The total drop due to resistance with a quarter inch arc will, therefore, be

$$\begin{array}{rcl}
 10 \text{ amperes} \times \frac{3}{10} \text{ ohm in the carbons} & = & 3 \text{ volts.} \\
 10 \text{ amperes} \times \frac{1}{10} \text{ ohm in magnet} & = & 1 \text{ volt.} \\
 10 \text{ amperes} \times \frac{5}{8} \text{ ohm in arc} & = & 6 \frac{1}{4} \text{ volts.} \\
 10 & \times & \underline{1.025 \text{ ohms}} \\
 & & = 10 \frac{1}{4} \text{ volts.}
 \end{array}$$

Consequently, if there were no Counter E. M. F. present in the arc, a pressure of $10 \frac{1}{4}$ volts, maintained at the terminals of the mechanism, would be sufficient to produce a current of 10 amperes. In point of fact, however, this is far from

being the case. A total E. M. F. of, approximately, 45 volts is required to maintain the arc. Here the additional 35 volts ($34 \frac{3}{4}$) is required to overcome the C. E. M. F. of the arc at the positive crater.

The resistance of a carbon voltaic arc, that is to say, the resistance of the column of carbon vapor between the two carbon electrodes, like that of all ordinary matter, follows Ohm's law; that is it varies directly with the length and inversely with the area of cross-section. Consequently, if we could maintain the area of the vapor column constant, as the length of the arc increased, the resistance of the column would vary directly with its length. This, however, is seldom the case; for, as the length of the arc increases, the tendency is for the vapor to

spread laterally in all directions, thus increasing its cross-sectional area, and, it may sometimes happen, that the increase in the resistance caused by an increase in the length of the arc, may be more than compensated by the decrease in its resistance caused by the attendant increase in the area of the cross-section.

If the distance separating the two carbon electrodes remains constant, the cross-sectional area of the column of carbon vapor will depend upon the current strength through the arc; for, if the current strength be increased, the increased volatilization must necessarily produce an increased area of cross-section, with a consequent decrease in the resistance of the arc. Whether the drop in the arc will be greater or less on the increase of current, will depend upon whether the decrease in

the resistance due to the widening of the vapor column has been sufficient to compensate for the greater current strength. Thus, if the resistance of the arc, at a given length, was 1 ohm, and the current strength through the arc 10 amperes, then the drop in the arc would be $10 \times 1 = 10$ volts. If now, with the same length of arc, the current were doubled; *i. e.*, increased to 20 amperes, the resistance of the arc would be less, owing to the greater area of cross-section of the carbon vapor. If the resistance were reduced to $1/2$ ohm, the drop in the resistance would be $20 \times 1/2$ or 10 volts as before, making the total pressure at the terminals of the lamp the same as before the current was increased, on the generally recognized assumption that the C. E. M. F. at the surface of the crater is constant.

A very short arc has comparatively little room to spread, owing to the edges of the crater, and, consequently, such an arc cannot greatly decrease its resistance by lateral spreading. On the contrary, a long arc has abundant room for lateral spreading, and its resistance is capable of being markedly diminished by an increase in current strength. In view of the preceding principles we arrive at the two following laws:

(1) If the current strength passing through a carbon arc be maintained constant, the pressure at the terminals of the arc is always increased by increasing the distance between the carbons; or, in other words, the apparent resistance of the arc, will always be increased by an increase in its length, although said increase may not be exactly proportional to the length, owing to the tendency to lateral spreading.

(2) If the distance between the carbons be maintained constant, and the current through the arc be increased, then the apparent resistance of the arc may either increase or diminish. It will usually increase when the arc is very short, that is to say, when there is very little room for lateral spreading, and it will usually decrease when the arc is sufficiently long to afford ample room for laterally spreading. Between these two conditions there will be a certain length of arc, at which the lateral spreading will diminish the resistance as fast as the current increases; or, in other words, when the pressure at the terminals of the lamp will be constant for a wide range of current at all current strengths.

From the preceding, it will appear that the C. E. M. F. of the arc constitutes a

much greater part of the total E. M. F. maintained at its terminals, than that required to overcome the mere *ohmic resistance*, that is, resistance due to the character of the carbon vapor forming the arc, its length and areas of cross-section. The origin of this C. E. M. F. in the arc is now generally ascribed to the volatilization of the carbon in the positive crater, and, since this volatilization is able to occur, as we have seen, only at a fixed temperature, it is evident that the value of the C. E. M. F. will not greatly vary with changes in the dimensions of the arc.

If we take the C. E. M. F. of the arc as being 35 volts (its range being generally accepted between 35 and 40 volts), and add this to the total drop of say 10 volts, the total C. E. M. F. at the main terminals will be 45 volts, and the E. M. F. which

has to be maintained at the terminals to overcome this total C. E. M. F. will similarly be 45 volts. If now, the resistance of the shunt magnet S , be 450 ohms, the current strength which will pass through it will, by Ohm's law, be $45 \div 450 = \frac{1}{10}$ ampere. Should the arc through volatilization and oxidation, be now lengthened, to say $1/2$ inch, the resistance will be increased from $5/8$ th ohm to, roughly, $2\ 1/2$ ohms, and the drop of pressure due to this will be increased, assuming the same 10 amperes of current strength, from $5/8$ th \times 10, or $6\ 1/4$ volts, to $2\ 1/2 \times 10$ or 25 volts. This will represent an increase of nearly 19 volts of drop, being the total pressure at the terminals of the lamp from 45 to about 64 volts, on the assumption that 10 amperes is steadily maintained through the circuit. The current strength,

which will now pass through the shunt magnet, will be $\frac{64}{450} = \frac{1}{7}$ th ampere, approximately, instead of $\frac{1}{10}$ th, an increase of about forty per cent. The undue lengthening of the arc has thus increased the strength of the shunt magnet to about forty per cent.

All arc lamps containing derived-circuit feeding mechanisms necessarily employ, either actually or effectively, at least two electromagnets, one in the main circuit, called the *main-circuit magnet*, and the other in the derived circuit around the arc, and called the *shunt magnet*. From what has been said concerning shunt circuits, in connection with Fig. 12, it is evident, that when during the operation of the lamp, the resistance of the arc proper increases,

the strength of current which flows through the shunt magnet increases. The mechanism employed in connection with the shunt magnets is of such a nature that the shunt magnet opposes, or tends to oppose, the action produced by the direct magnet. For example, if, as is the case in most arc lamp mechanisms, the function of the direct-circuit magnet is to effect the separation of the carbons, and thus to establish the arc between them, the function of the shunt magnet is to cause their approach, whenever the distance between the carbons is increased beyond a certain predetermined limit.

In nearly all arc lamp mechanisms, the positive carbon is connected to a cylindrical vertical metallic rod called the *lamp rod*. This rod is so connected with the armature of the direct magnet, or with its

core, that on the attraction of the armature or core, a *gripping device* takes hold of the lamp rod and raises it, thus effecting the separation of the carbons, and establishing the arc. At the same time, the armature, or core of the shunt magnet, is in such connection with the gripping device, that, on the attraction of its armature or core, the gripping device is caused to loosen its hold on the lamp rod thus permitting the lamp rod to fall and causing the carbons to approach. It is evident, therefore, that as the carbons gradually burn away and the lamp gradually pulls a long arc, the current strength passing through the shunt magnet increases, until at last it becomes sufficiently strong to release the clutch or gripping mechanism and thus permit the carbons to fall. Since the feeding of a derived circuit lamp is thus clearly dependent on the

pressure at its terminals, and not on the pressure at the terminals of any of the other lamps in the series-connected circuit, it is evident that the feeding of each lamp is

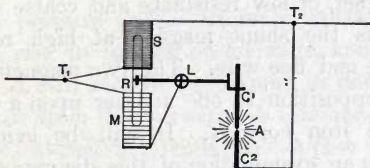

FIG. 13.—DIAGRAM OF EARLY SIEMEN'S REGULATOR.

entirely independent of all the other lamps in the circuit.

One of the early forms of the *derived-circuit lamp*, or, as it is frequently called, the *differential lamp*, owing to the differential action of the two magnets, is shown in the Siemens' regulator, in Fig. 13. Here the lower carbon C_2 is fixed,

and the upper carbon C_1 , is so supported at the end of the lever L , so as to be movable under the action of the two magnets S and M . M , is the main-circuit magnet, of low resistance and coarse wire. S , is the shunt magnet, of high resistance and fine wire. The two magnets act in opposition to one another upon a common iron core R . It will be evident, from an examination of this diagrammatic figure, that on the passage of the current through the magnet M , with the carbon rods initially in contact, the shunt magnet S , will be nearly short-circuited, nearly all the current passing through the magnet M , which will attract its core R , downward, practically unopposed by S . The downward motion of the core R , acting on the rod L , pivoted as shown, raises the upper carbon C_1 , whereupon the arc is established between the two car-

bons. This at once introduces an increased resistance into the circuit of M , due to the ohmic resistance of the arc, as well as the C. E. M. F. of the arc proper. The pressure at the terminals will, therefore, rise to say 45 or 50 volts, and the coil S , will receive its current, in derived circuit from this pressure, so that its magnetic attraction tends to oppose the action of the magnet M . The core R , under the joint action of both these magnets, will come to rest in a position which will enable the proper length of the arc to be obtained. Matters will remain in this condition until, by the consumption of the carbons, the arc becomes unduly lengthened whereby, as we have seen, the pressure at the terminals will be unduly increased. This will strengthen the shunt magnet S , while it will not strengthen the direct magnet M . Under

these new conditions, the core R , will be lifted, causing the lever L , to depress the upper carbon C_1 , and to release it by gravitation through the action of a clutch arranged for that purpose.

The details of the mechanism of the Siemen's differential lamp are shown in Fig. 14. RR , is the main magnet, TT , the shunt magnet. The lamp rod z , is furnished with a long ratchet by which its descent is controlled under the action of the core SS , and the escapement wheel r .

A particular form of modern arc lamp mechanism is illustrated in Fig. 15, where the metal cover is slipped down to reveal the interior. Here the terminals, T, T , are provided for the reception of the wires supplying the lamp, the main-circuit magnet M , is wound with coarse wire, and

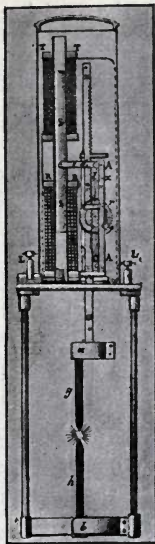

FIG. 14.—SIEMEN'S ARC LAMP.

the shunt magnet S , with fine wire. These magnets, by their attractive influ-

ence, determine the position of the armature AA , pivoted at V . When the action of the main magnet preponderates, the armature moves upward; when the shunt magnet preponderates, the armature moves downward. The lower, or negative carbon, not shown in the figure, is clamped in its holder or socket at the lower end of the lamp. The positive carbon C , is attached to the lower extremity of a vertical guide-rod, armed with a rack. This guide-rod is supported by the armature AA , through the intermediary of a pinion wheel. Consequently, when the armature A , is raised by the action of the main magnet, when the current first passes through the lamp, it raises both the upper carbons and the pinion wheel, thus establishing the arc. The weight of the carbon and its rod, tend to make the rack on the rod

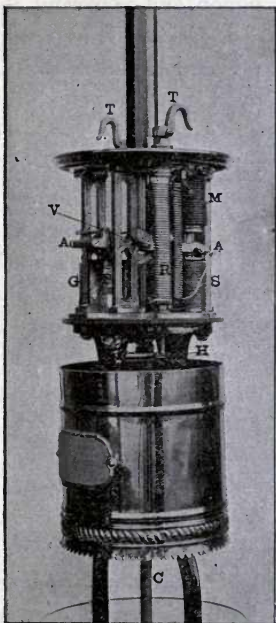

FIG. 15.—FORM OF ARC LAMP MECHANISM.

drive the pinion and so permit the upper carbon to descend. This tendency is, however, prevented when the armature is lifted by a pawl engaging with the wheel work. As soon as the arc becomes unduly lengthened, the attraction of the shunt magnet becoming thereby greater than that of the main magnet M , the armature AA , descends slightly, and effects the disengagement of the pawl, thus releasing the wheel work and permitting the upper carbon to slowly descend toward the lower carbon, until such length of arc is obtained as will permit the action of the two magnets to balance each other, and the pawl to re-engage. A spiral spring G , attached to the end of the armature, opposes the action of the shunt magnet, and, therefore, enables a certain range of mechanical adjustment to be made after

the windings have been placed on the electromagnets; for, by tightening this spring, the arc must be longer and the current through the shunt magnet *S*, stronger, before its attraction will cause the armature to descend and release the wheel work. The contact springs *P*, carry the current into the upper carbon by pressing against the lamp rod. Below the mechanism chamber, and external to it, is the handle *H*, of a small switch, intended for short-circuiting the lamp. *R*, is a coil of German silver wire, wound on asbestos, and serving as a resistance, the function of which will be presently described.

A diagram of the connections of this lamp are indicated in Fig. 16. The terminals are marked at *T, T*, the right-hand terminal being positive. The current, therefore, enters at the right-hand terminal, and,

under normal conditions, passes to the metal framework of the lamp mechanism,

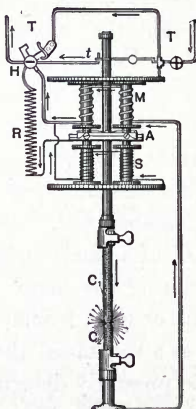

FIG. 16.—DIAGRAMMATIC CONNECTION OF LAMP SHOWN IN FIG. 15.

from which it passes through the spring clip, not shown in this case, to the lamp rod. From the lamp rod it enters into the

upper or positive carbon C_1 , and passes through the arc, and into the lower or negative carbon C_2 . It then proceeds through the windings of the main-circuit magnet M , and finally reaches the negative terminal on the left-hand side. The shunt magnet S , is connected between the framework of the mechanism and the negative terminal. It is, therefore, evidently in shunt across the terminals T, T . The handle H , is not shown in this diagram, but the switch which it controls, is represented as being attached to the negative terminal in such a manner, that when operated by hand it enters the spring clip indicated, and directly short circuits the lamp. Another switch t , is also provided for effecting the same purpose, but in this case it is only operated by the lamp rod, when the carbons have been nearly consumed, thus protecting the lamp rod and

carbon holder from the dangerous proximity of the arc.

If by any cause, the lamp rod should be held up, and fail to feed, so that the carbons cannot approach, and the arc is finally extinguished, then the only circuit remaining for the current through the lamp would be through the high-resistance shunt-winding, and this would not only greatly increase the resistance of the entire series system, thus interfering with the proper operation of the other lamps, but would soon result in the destruction, by overheating, of this winding. In order to prevent this occurrence, it is arranged that a powerful attraction exerted by any excessive current through the shunt magnet S , exerted upon the armature A , will cause the end of the resistance coil R , connected with the armature, to be brought

into contact with the metal framework of the lamp, thereby establishing a shunt circuit, of low resistance, directly across the terminals. The drop of pressure produced in this resistance R , will be sufficient to leave some excitation in the shunt magnet S , and retain the armature in this position. It will also be sufficient to enable the main circuit magnet M , to be called into action should the lamp rod again be permitted to descend, thus restoring the lamp to its proper action.

Fig. 17, represents another form of arc lamp mechanism. Here the same letters refer to similar parts of Fig. 15. It will be observed, however, that in this case, the rack-and-pinion motion is replaced by a clutch, mounted on the armature lever, so that, when the armature A , is attracted to the main-circuit magnet M , the clutch

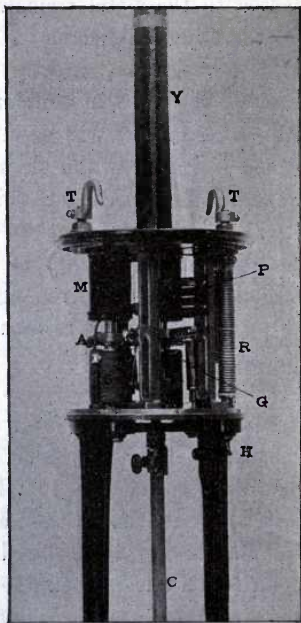

FIG. 17.—FORM OF ARC LAMP MECHANISM.

grips the lamp rod and raises it, thus establishing the arc; while on the attraction of the armature by the shunt magnet S , the grip or clutch is released, thus permitting the positive carbon to fall by gravity toward the negative carbon, until the proper length of arc is reached.

Another form of arc lamp mechanism in common use, is shown in Fig. 18. Here the terminals T, T , are connected with the interior parts. The magnets M, M , are of the *differential type*, and contain both coarse and fine wire windings on the same spools. The coarse wire, as before, being in the main circuit, and the fine wire, in the shunt or derived circuit. These coils are so wound or connected, that the effect of the current in one, is opposed to that of the current in the other, thus obtaining the electrical equivalent to the mechanical

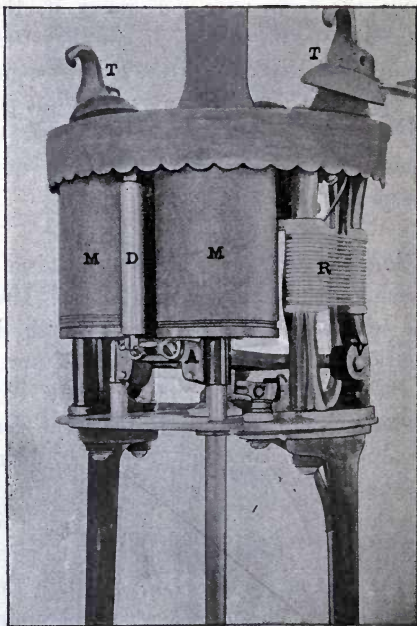

FIG. 18.—FORM OF ARC LAMP MECHANISM.

differential principle. D , is a *dash-pot*, or *damping cylinder*, containing air, provided to check the too sudden movements of the armature A , with which it is connected. The armature is pivoted at V . R , is a resistance, and G , a special form of cut-out. This form of lamp employs a *clutch*, or gripping device, whereby the motion of the armature of the main-circuit magnet, causes the clutch to grip or hold on to the carbon and thus effects the raising of the lamp rod and the establishment of the arc.

The form of clutching or clamping device employed in the above lamp is shown in Fig. 19. The left-hand side of the figure shows the clutch at grip, and the right-hand side of the figure, the clutch released. A , is the lamp rod, D and C , parts of the clutch, and E , a stop engaging with the plate G . The armature lever F ,

engages with the extremity of the piece, called the clutch lever, which is pivoted at *d*. When the armature *F*, as shown on the left-hand side of the figure, descends, it carries with it the clutch and lamp rod

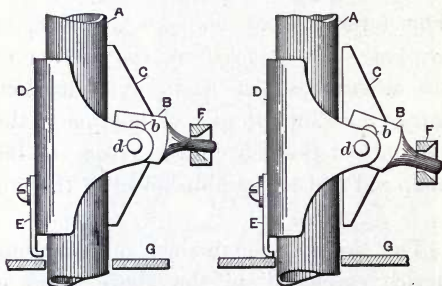

FIG. 19.—CLUTCH IN A SERIES ARC LAMP.

until the stop *E*, strikes the plate *G*, when the movement of the clutch is arrested, and the clutch lever *B*, is obliged to continue in its motion alone. By so doing it

disengages the saddle C , from the surface of the lamp rod, and permits the weight of the latter to draw it downward.

The connections of the preceding lamp mechanism are represented in Fig. 20. The positive and negative main-terminals are marked P and N , respectively. The double winding of the magnets is indicated in this figure by the full and dotted lines. At N , a small hand switch is indicated for completely short-circuiting the lamp. A special cut-out mechanism is provided at J , for cutting the magnets and carbons out of circuit under ordinary circumstances before the current is supplied to the lamp. K , is a temporary cut-out electromagnet brought into action on the failure of the lamp properly to feed. j and V , are special resistances. j , acts as a shunt to the main-circuit magnet, and is

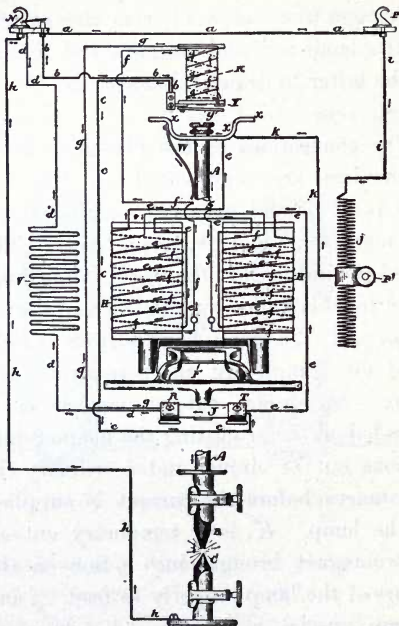

FIG. 20.—CONNECTIONS OF MECHANISM IN A SERIES ARC LAMP.

intended to be regulated by the thumb-screw p . In order to regulate the action of this magnet, a resistance, V , is in-

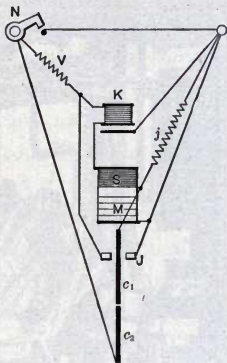

FIG. 21.—DIAGRAM OF CIRCUIT CONNECTIONS OF LAMP SHOWN IN FIG. 18.

serted for purposes of retaining a drop of pressure in the lamp mechanism, when the cut-out is used, of sufficient amount to

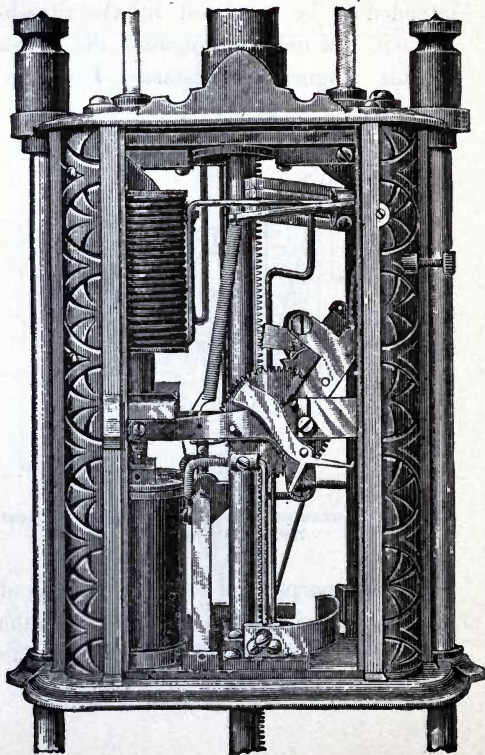

FIG. 23.—INTERIOR MECHANISM OF A SERIES ARC LAMP.

bring the lamp into operation as soon as it is ready to operate.

Fig. 21, gives a simplified diagram of the connections in this case. When no current passes through the lamp, the terminals of the cut-out J , are bridged across by a gravitation switch. As soon as current passes through the lamp it traverses this short circuit J , and the resistance V . The drop of pressure in the resistance V , will however, be sufficient to allow a current to pass through the main circuit coils M , and the carbons $c_1 c_2$, provided that these latter are in contact. The excitation of the coil M , will cause the cut-out J , to be broken, and the upper carbon to be lifted, thus establishing the arc. If the pressure across the arc becomes excessive, the shunt winding S , neutralizes the main winding M , sufficiently far to permit the clutch to

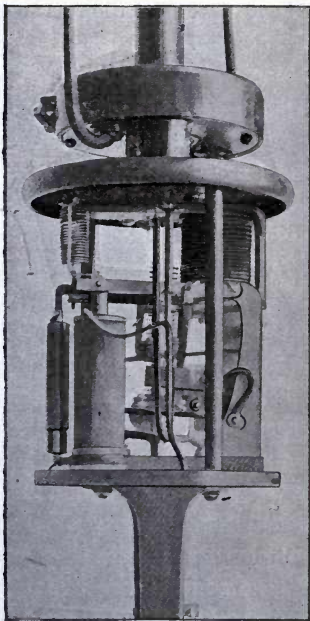

FIG. 23.—INTERIOR MECHANISM OF ARC LAMP.

relax and the carbon to feed. If the current through S , becomes excessive the cut-out magnet K , short circuits the lamp.

An exceedingly great number of arc lamp mechanisms have been devised, many of which are in extended use. Though all of these forms differ in minor details and in the arrangement of interior circuits, yet practically all lamps suitable for series connection in arc-light circuits are designed on essentially the same general principle; that is to say, an electromagnet in the main circuit operates on mechanism which effects the separation of the carbons, while another electromagnet, placed in the shunt circuit, effects an approach of the carbons. Moreover, all of these lamps are provided with some form of automatic cut-out device, which prevents the failure of any one lamp to

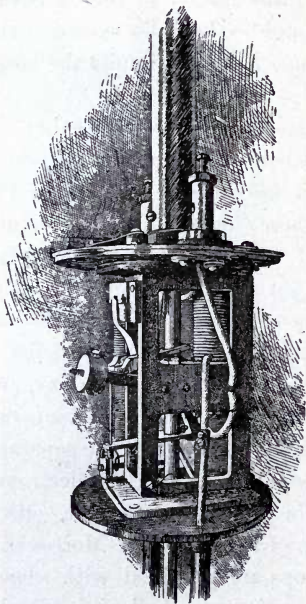

FIG. 24.—MECHANISM OF ARC LAMP.

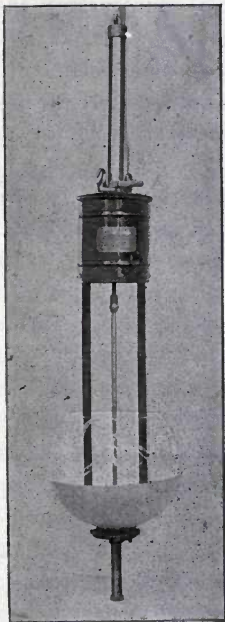

FIG. 25.—SINGLE CARBON ARC LAMP.

operate, from extinguishing the entire circuit. In addition a hand switch is employed for convenience in cutting out the lamp when not required for use, as well as for safety in re-carboning the lamp.

A few other forms of lamp mechanisms are illustrated in figures 22, 23, 24 and 25.

CHAPTER V.

SERIES-CONNECTED ALL-NIGHT LAMPS.

DURING the continuance of the arc, on account both of the volatilization and combustion of the carbon with the oxygen of the air, a wasting or consumption of the electrodes takes place. In the case of the positive carbon this wasting is due both to volatilization and to oxidation; the negative carbon having, as we have seen, a lower temperature, only wastes through oxidation. Moreover, the rate of consumption of the negative carbon is prolonged by the fact that it receives a deposition of cooled carbon vapor from the positive crater. The positive carbon, therefore,

consumes or wastes away more rapidly than the negative carbon. This rate of consumption will necessarily vary with the character of the carbons, with their size and with the strength of current employed, but with the carbons ordinarily employed, the consumption of a 1/2" positive rod, in a 2,000 candle-power lamp, takes place at a rate somewhat greater than one inch per hour. The rate of consumption of the negative carbon is about half as much, or about 1/2" per hour.

Since, during the winter nights in high latitudes, the hours of darkness greatly exceed the life of the 12" \times 1/2" carbon, which is approximately nine hours, a necessity arises for re-carboning the lamp, during its use. In order to avoid this necessity, and produce what is called an *all-night arc lamp*, various devices have

been employed. An early method of obtaining this result was that devised by De Mersanne. It might be supposed that the problem of producing an all-night lamp could readily be solved by increasing the length of the carbons, but a little reflection will show, that since the positive carbon in nearly all forms of lamp mechanisms is connected to the lamp rod, whose length, in order to permit of continuous feeding, is approximately the same as the positive carbon, too great an increase in the length of the positive carbon would make the lamp unwieldy and would limit its use to rooms with high ceilings. Moreover, the necessity existing in all arc lamp mechanisms in which the carbons are vertical, of obtaining truly straight carbons free from curvature, would be greatly increased with the increase in length.

De Mersanne in endeavoring to solve the problem of all-night lamps, devised a mechanism in which this objection arising from the excessive length of the carbons is avoided. In his regulator, the carbons were placed horizontally, both in the same horizontal line. By employing carbons a metre or more in length, he was able to obtain a duration of light exceeding that of the longest night in winter. The De Mersanne regulator can scarcely be regarded as having possessed commercial merit, since the expense of the carbons and their liability to fracture, were greater than in the ordinary lamp. Moreover such lamps necessarily produced an irregular distribution of light, from the fact that the positive crater, being horizontal, threw more light in one direction than in another.

It might be supposed that the problem of all-night lighting would find a ready solution in increasing the diameter of the carbons, and many inventors have produced lights of this type. From what has been said concerning the liability of the arc to travel, where carbons of fairly large diameter are employed, and the consequent unsteadiness of the light so produced, it is evident that such forms of all-night lamp are objectionable from the flickering of the light they produce. An early form of large carbon, all-night lamp devised by Wallace, is represented in Fig. 26. Here the carbon electrodes are formed of plates instead of rods, the arc being formed at some point between them. In this form of lamp, like the arc lamp mechanisms already described, when no current is passing, the carbons are in contact. On the passage of the current the

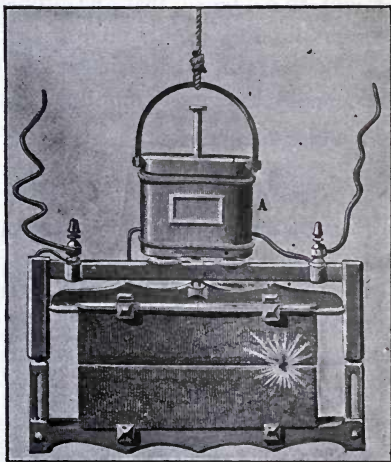

FIG. 26.—THE WALLACE ALL-NIGHT LAMP.

carbon plates are separated, and the arc is established at the nearest points between their opposed surfaces. In practice, however, the light produced by this form of

lamp proved so unsteady from the tendency of the arc to travel, that it never attained extensive use.

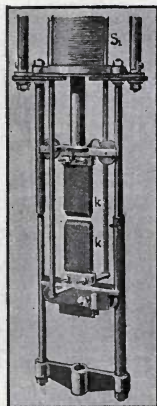

FIG. 27.—PILSEN LAMP.

A similar type of lamp is shown in Fig. 27, named the Pilsen lamp. It is practically identical with the Wallace lamp, ex-

cept that the plates are narrower. Like the Wallace lamp this never gave a satisfactory steady light.

Notwithstanding the unsatisfactory service of the above type of lamp, many inventors have endeavored to solve the problem of all-night lighting in a similar manner, by the employment of carbons of fairly considerable diameter. In some forms of such lamps, both carbons are made large; in others, only one, generally the positive carbon is increased in dimensions. Probably the most practical form of lamp of this general type was one employed at a very early era in arc lighting (1845), by an English inventor, named Wright. This lamp more nearly solved the problem in that, although large masses of electrodes were employed, yet the position of the arc was maintained fairly constant and the

consumption rendered fairly uniform. In Wright's all-night lamp, one or both of the carbons had the form of a disc, the

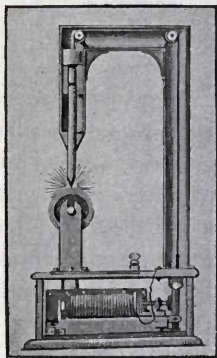

FIG. 28.—HARRISON'S LAMP.

arc being established either between two discs, rotating in planes at right angles to each other, or, as in a modified form of Wright's lamp invented by Harrison in

1857. Harrison's regulator is shown in Fig. 28. Here the arc is established between a vertical carbon rod, and a disc revolving beneath it. The operating mechanism is placed in the lower part of the lamp.

An evidence of the tendency at a later date to attempt to obtain an all-night lamp by increasing the size of the carbons, is seen in the form of lamp represented in Fig. 29. Here elliptical carbons are employed, both of which are made of fairly large area of cross-section.

Another endeavor in the same direction is shown in Fig. 30. Here the upper carbon is of markedly large dimensions, and, in order to render the consumption of its surface more nearly uniform, the upper carbon in being fed is given a lateral

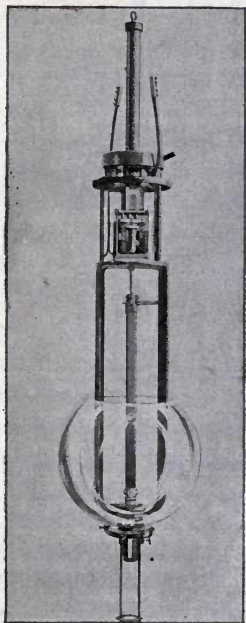

FIG. 29.—ALL-NIGHT ELLIPTICAL CARBON LAMP.



FIG. 30.—RECIPROCATING CARBON ALL-NIGHT LAMP.

slow reciprocating motion, so as to bring fresh portions of its surface into action. This lateral motion is obtained with the aid of a rack shown on the right hand side of the frame.

Perhaps, the best solution for all-night series arc lamps has been found in what are called *double-carbon lamps*, or *twin-carbon lamps*. This type of lamp, as the name indicates, consists essentially of a lamp provided with a mechanism which controls a double set of positive and negative carbons, of the same size as those used in ordinary lamps. The mechanism is such that on the passage of the current through the lamp only one pair of carbons is so separated that the arc can be formed between them, the other pair being separated too far to permit the arc to be maintained between them. In most forms of double-carbon lamps, the same feeding mechanism is employed for each set of carbons, the arrangement being such that it brings one pair of carbons into action, and when this pair is consumed the second pair automatically receives the current. The means by

which one of the earliest forms of these lamps effected this result is shown in Fig. 31. In this form, the clamp or lifting device is represented as a ring-clutch or

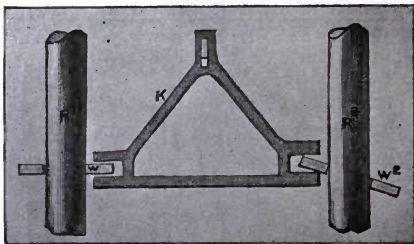

FIG. 31.—BRUSH WASHER OR RING CLAMP.

clutch-washer. It is evident that when such a ring is maintained in a horizontal position, the lamp rod can slip through it, but when tilted, it grips the lamp rod at diagonally opposite corners.

In order to ensure the formation of the arc between one pair of carbons only, the

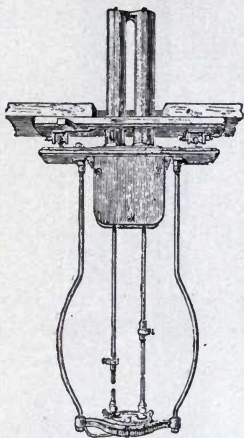

FIG. 32.—BRUSH DOUBLE LAMP.

lifting device *K*, that acts on the washer-clutch by the jaws which embrace them, has one pair of jaws wider than the other

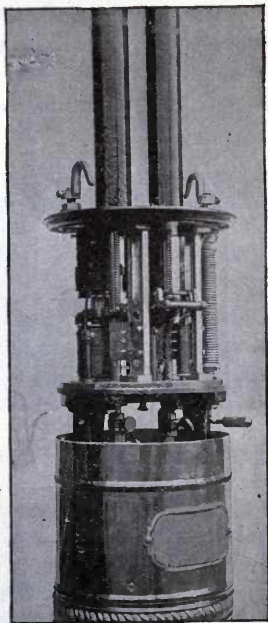

FIG. 33.—MECHANISM OF A SERIES DOUBLE-CARBON
ARC LAMP.

pair, so that when the frame is lifted, the washer connected with the wider jaws takes a grip before the other, and, consequently, lifts its carbon higher than the other. In this case the arc is permanently established across the shorter distance, and the subsequent feeding of the lamp mechanism affects this pair of carbons alone, and not the other pair, because though these are raised and lowered with the first, yet the distance between them is too great for the arc to be established. When, however, the consumption of the carbons has reached the point when they can no longer come into contact, and the frame drops, the arc is established between the other pair of carbons and continues there until they are consumed. The appearance presented by this form of double lamp is shown in Fig. 32. An inspection of this will show that the same

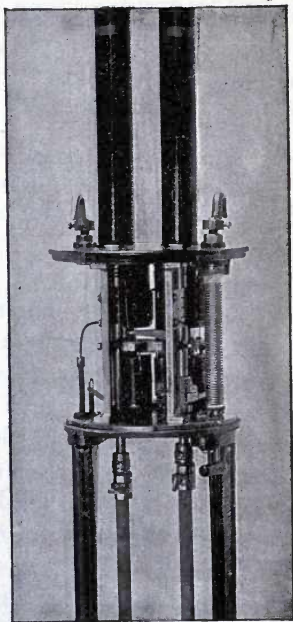

FIG. 34.—MECHANISM OF A SERIES DOUBLE-CARBON
ARC LAMP.

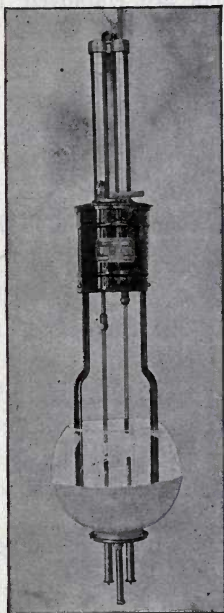

FIG. 35.—FORM OF DOUBLE-CARBON ARC LAMP.

electromagnets are employed to operate both pairs of carbons.

Fig. 33 represents the mechanism of another form of double-carbon lamp, provided with gear feed. Here the apparatus is essentially the same as that already described in connection with Fig. 15, a simple device being provided, whereby, when one pair of carbons is consumed, the current is automatically sent to the other.

Fig. 34 represents the clutch feed mechanism in a double-carbon arc lamp. Here the mechanism is of the same type as that shown in Fig. 17.

Fig. 35 represents still another form of double-carbon arc lamp.

CHAPTER VI.

CONSTANT-POTENTIAL LAMPS.

ARC lamps, as we have already seen, may be connected either in series or in parallel. If we assume that each lamp takes a current of 10 amperes, when supplied with a constant pressure of 45 volts at its terminals, then the activity developed in the lamp will be 450 watts. If now, 100 of these lamps have to be lighted together, it is possible to connect them either in series or in parallel. If they are connected in series, the current strength in the circuit must everywhere be 10 amperes, but the pressure at the dynamo terminals, if we

neglect the drop of pressure in the line wires, will be $100 \times 45 = 4,500$ volts. On the other hand, if we connect the lamps in parallel, each lamp will take 10 amperes, and the total current supplied by the dynamo will, therefore, be $10 \times 100 = 1,000$ amperes, at a pressure, neglecting drop in the line wires, of 45 volts. It is evident, therefore, that a series circuit is essentially a high-tension but low-current circuit, and that a multiple or parallel circuit is essentially a low-tension but high-current circuit; but, neglecting the drop of pressure, or power expended, in the line wires, the amount of energy delivered to the circuit will, in each case, be the same. Thus, the series circuit would take from the dynamo $4,500$ volts \times 10 amperes = 45,000 watts = 45 KW. The multiple circuit would take 45 volts \times 1,000 amperes = 45,000 watts = 45 KW.

When, however, we come to study the effects of adopting one or other of these two systems of distribution upon the nature and amount of line wire employed, we are met with a very marked contrast. In the case of the series circuit, it is evident that the line wire has to carry a current of but 10 amperes, and, consequently, its dimensions will always be comparatively small. The size of wire commonly adopted for arc lighting in such circuits, is No. 6 B. & S. (Brown & Sharpe) or A. W. G. (American Wire Gauge). This wire has a diameter of 0.162", and a resistance per mile of a little more than 2 ohms.

Suppose now that these 100 arc lamps have to be distributed uniformly around a circle of 10 miles circumference, as shown in Fig. 36, adjacent lamps being, therefore, 528 feet apart. On the series system

the length of No. 6 wire required would be 10 miles, offering a total resistance, of say 20 ohms. The total drop of pressure in

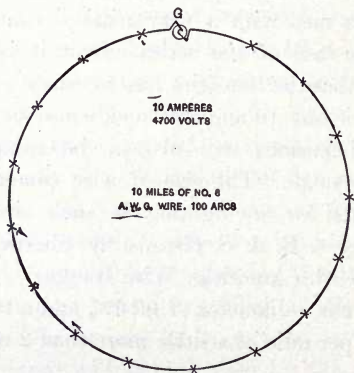

FIG. 36.—SERIES ARC LIGHT DISTRIBUTION.

the wire, would, therefore, be 10 amperes \times 20 = 200 volts, making the pressure at the dynamo terminals 4,700 volts, repre-

senting a total activity of 47 KW, or 2 KW, expended uselessly in the line wire.

If, however, 100 arc lamps be supplied in parallel, from two wires carried around the circle from a single point of supply, as shown in Fig. 37, then, in order to have 2 KW, expended in the wires as before, or in other words, to maintain the same economy in distribution, it would be necessary to employ two wires, each having, approximately, 2,500 times the weight and cross-section of the No. 6 wire in the preceding case, so that the total weight of copper will be increased about 5,000 times.

It is evident, therefore, that parallel distribution is far more expensive for conductors, at a given efficiency of transmission, than series distribution, and the amount of copper which has to be employed increases

inversely as the square of the pressure. Thus, if we raise the pressure 10 times at the dynamo brushes, we employ 100 times

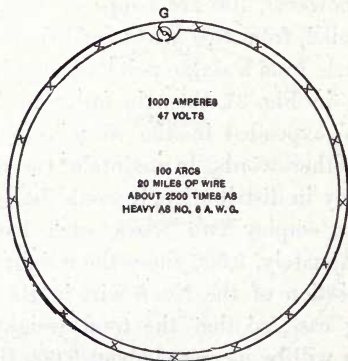

FIG. 37.—PARALLEL ARC LIGHT DISTRIBUTION.

less copper in the distributing system, other things remaining the same. In other words, in the series circuit, the economy increases with the number of

lamps connected in the circuit, while in the parallel circuit, the economy decreases with the number of lamps in the circuit. On the other hand, however, when the distance to which the lighting has to be extended is comparatively small, as frequently occurs, for example, in large buildings, or in streets of large cities, the difference between the economy of distribution by series and by parallel systems greatly diminishes.

Large cities are generally supplied with incandescent lighting by systems of underground mains. When these mains form part of a *low-pressure system*; *i. e.*, of a system employing a pressure not in excess of 250 volts, it will generally be found more convenient to light a certain number of arc lamps from such circuits, rather than install a special series circuit and system.

This convenience is evidenced by the fact that in a single city,—Brooklyn,—there are at the present time no less than 3,750

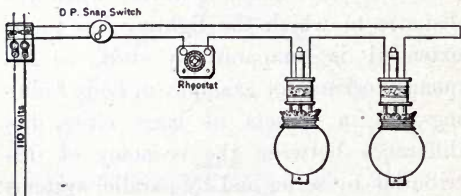

FIG. 38.—INCANDESCENT CIRCUIT, WITH SHORT LAMPS.

arc lamps operated in parallel from the low-tension system of 230 volts.

Since the pressure in the low-tension incandescent system is never less than 110 volts, in order to utilize such a system, to as great advantage as possible, in arc lighting, it is necessary to place two arc lamps in series across such mains. If only one

lamp requires to be installed, additional resistance is inserted with the single lamp. Fig. 38 represents two arc lamps, of the short, stumpy character, suitable for low ceilings, connected in series with a rheostat and controlled by a double-pole snap switch, from a safety block, connected with the 110-volt circuit.

Fig. 39, represents the same arrangement in the case of two lamps, in which case no additional resistance outside the lamps is required. Such lamps, however, usually insert a resistance in their interior, capable of maintaining a drop of say 10 volts, when in operation. Four arc lamps are sometimes joined in series across 250 volts pressure, and eight or nine across a 500-volt railway circuit.

Fig. 40, illustrates the connections of a

lamp of the same type as that shown in Figs. 15, 17, and 33, but arranged for low-tension circuits. The only essential differ-

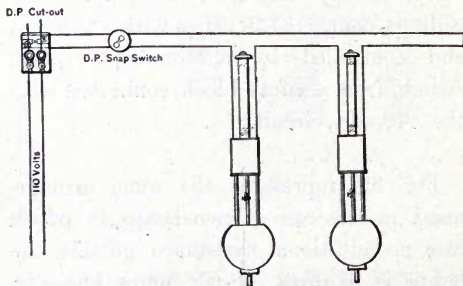

FIG. 39.—INCANDESCENT CIRCUIT WITH TWO ARC LAMPS.

ence between this arrangement and that of Fig. 15, lies in the fact that the hand switch represented at the negative terminal does not short circuit the lamp, but merely breaks its circuit, also that a safety fuse is placed between the lamp and the line,

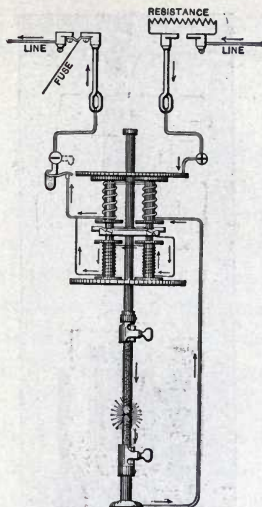

FIG. 40.—CONNECTIONS OF CONSTANT-POTENTIAL ARC LAMP.

on one side, and a fixed resistance, between the lamp and the line on the other side. The fuse is intended to cut the lamp out

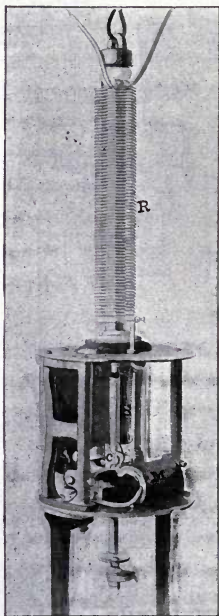

FIG. 41.—INTERIOR MECHANISM OF A FORM OF CONSTANT-POTENTIAL ARC LAMP.

of circuit, in the manner of an automatic switch, should the current become excessive.

Fig. 41, represents a form of arc lamp mechanism suitable for use on constant-potential circuits, and corresponding to the type of mechanism for series circuits represented in Fig. 18. In this form of lamp the carbons are not in contact when no current is passing through the apparatus. The main-circuit magnet is horizontal and is marked *M*. The shunt-circuit magnets are marked *S*, and the clutch *c*. A long resistance coil *R*, is designed to be covered by a suitable tube, not shown in the figure.

Fig. 42, is a diagram showing the connections of the preceding lamp mechanism. On the completion of the circuit

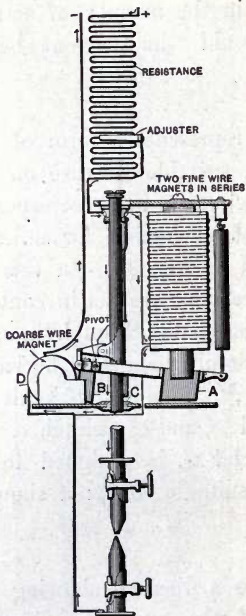

FIG. 42.—CONNECTIONS OF ARC LAMP MECHANISM SHOWN IN FIG. 39.

through the upper resistance, the current passes through the fine wire vertical coils alone, since the carbons are not in contact; the armature *A*, is raised and the clutch is thereby depressed, carrying with it the lamp rod and upper carbon until contact is made beneath, with the lower carbon. The current then immediately passes through the carbons, and the main-circuit magnet, which, being more powerful than the shunt magnet, opposes and overcomes its pull, by raising the armature *B*, thus lifting the upper carbon to the proper distance and establishing an arc. The position of the armature lever is determined by the relative powers of the opposing main and shunt magnets. As soon as the arc becomes too long, the main magnet weakens, while the shunt magnet strengthens, thus depressing the lamp rod and clutch, until the clutch stop strikes the

plate *C*. When this happens, the clutch releases slightly and enables the lamp rod to make a small descent, shortening the arc.

Another form of gear-feed, constant-potential, arc-lamp mechanism, is shown in Fig. 43, where *MM*, are the main circuit magnets and *SS*, the shunt magnets. The lamp rod is rectangular in cross-section and is provided with rack teeth on one face. The pinion mounted on an arbor carrying the wheel *W*, engages with this rack. The wheel *W*, also engages with a pinion on a second arbor carrying a second or trawl wheel with fine teeth cut in its periphery. Before the current passes through the lamps the carbons are in contact. As soon as the current passes through the main-circuit magnets, which are hollow spools, the cores *A A*, which constitute the armature,

the lever frame $k k'$ by the jaw J . The frame $K K'$, is pivoted at V , and on the

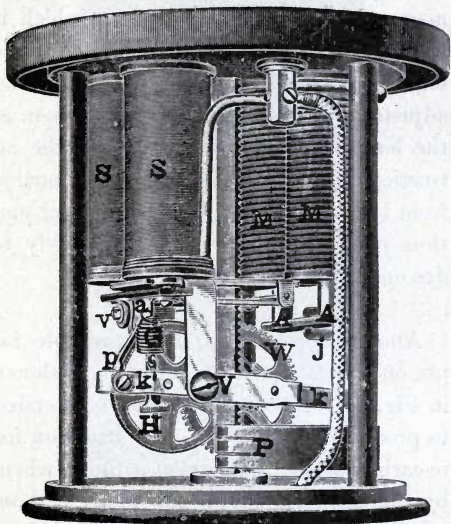

FIG. 43.—INTERIOR MECHANISM OF A FORM OF CONSTANT-POTENTIAL ARC LAMP.

elevation of the end K , the pinion forces up the lamp rod thus separating the carbons and establishing the arc. The shunt magnets attract the armature a , which is held in position by the spring G . The tension of this spring is capable of being adjusted by the screw head H . As soon as the length of the arc is excessive, the attraction of this armature releases the pawl p , from the periphery of the trawl wheel, and thus permits the upper carbon slowly to descend.

Another form of arc lamp, suitable for use on constant-potential circuits, is shown in Fig. 44. This form of lamp is intended to produce light without any attention for re-carboning for 50 hours at a time; when, by merely pushing up the lower carbon, it will furnish light for another period of 50 hours. Although half inch carbons are



FIG. 44.—FORM OF ARC LAMP FOR CONSTANT-POTENTIAL CIRCUITS.

used, and although the length of the positive carbon is only 12", yet by the method employed, the carbons last, as already stated, for at least 100 hours. The means whereby this increased duration is obtained are very simple. A semi-opalescent shade *D*, Fig. 45, surrounds the arc. This chamber is closed, but not air tight. As soon as the lamp is lighted, the air surrounding the arc is rapidly deprived of its oxygen, so that the residual atmosphere consists of carbon monoxide and nitrogen in a heated, and, therefore, rarefied condition. The outer chamber contains a store of these inert gases, which are practically prevented from escaping owing to the fact that the top of the outer globe is air-tight, so that the external air can only enter at the base of the external globe by diffusion. Consequently, the carbons are soon surrounded by an inert atmosphere which



FIG. 45.—ARC LAMP, WITH OUTSIDE GLOBE REMOVED.

greatly prolongs their life. The positive carbon consumes at the rate of about $1/20$ th inch an hour, and the negative carbon at the rate of about $1/50$ th inch. In fact almost the entire consumption is due to volatilization, in contradistinction to combustion.

Fig. 46 partly shows the mechanism in this form of lamp. A hollow spool or solenoid M , in an iron frame $F F'$, is provided with a soft iron armature core A , which holds, in its interior, the upper carbon. When no current passes through the lamp, the upper carbon falls by gravitation on to the lower, establishing a circuit through the lamp. When the current is allowed to pass through the lamp, the solenoid M is energized, and the armature A , is lifted, thus gripping the carbon and establishing the arc.



FIG. 46.—FORM OF ARC LAMP FOR CONSTANT-POTENTIAL CIRCUITS, SHELL AND OUTSIDE GLOBE REMOVED.

Fig. 47 is a section of the mechanism just described, *MM* is the magnetizing coil in the iron frame *b b b b b b*. The armature core *a a a a a a*, is provided at its upper extremity with a conical extension suitably conformed to a similar cone on the field-magnet frame. Within the armature is the upper or positive carbon *c c*, and its brass tube holder *t t*. At the lower extremity of the armature are ring clamps, *p, p*, which separate and release the carbon when the armature falls on to the tube *u u*, but which grip the carbon when the armature rises clear of this tube. In the lower cylinder *B*, are rings *r, r*, which do not interfere with the free movement of the carbon, but which maintain electrical connection with its surface, and supply it with the current. As soon as the armature lifts, under the action of the solenoid, the carbon *c c*, is gripped and raised to a distance

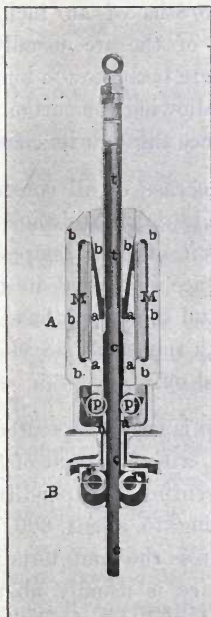

FIG. 47.—SECTION OF MECHANISM SHOWN IN FIGS. 44, 45 AND 46.

of about $\frac{3}{8}$ ths of an inch, this being the length of the arc usually employed. When the arc becomes too long, the armature falls, allowing the carbon to slip for a short distance through its clamps, *p*, *p*.

As in the case of all constant-potential lamps, an additional resistance is inserted in the circuit of each lamp. In Fig. 45, this resistance is placed in the crown of the lamp, and the switch handle *H*, in connection with the same, serves to turn the light on and off.

The lamp is usually operated from a 110-volt circuit, with a current of 5.5 amperes, thus representing an expenditure of activity amounting to about 600 watts. The pressure across the lamp terminals, beyond the resistance, is usually about 80 volts, representing a drop of about 30 volts in the additional resistance.

CHAPTER VII.

APPURTENANCES AND MECHANICAL DETAILS OF ARC LAMPS.

WE have heretofore described the electrical regulating mechanism of arc lamps, whereby the carbons are maintained at a constant distance apart, despite their consumption by combustion and volatilization. The mechanical details of construction of the arc lamp, together with poles, hoods, hangers and other appurtenances connected with their commercial use, will now claim our attention.

An arc lamp proper may be regarded as being composed essentially of the following parts; namely, of the feeding and

regulating mechanism which we have already described, the lamp, frame and cover, the carbon holders, the globe holder and the globe. Besides these, lamps are frequently provided with a hood for the double purpose of protecting them from the weather and also for throwing the light downwards. The separate lights are mounted on the tops of poles or suspended from cords or outriggers.

We have already pointed out the fact that the lamp rod which supports the positive carbon is, necessarily, of practically the same length as this carbon. The proper working of the lamp requires that the lamp rod be kept from dirt and oxidation. To ensure this, when the lamp is *re-carboned* or *trimmed*, this rod should be occasionally cleaned and is always protected from the weather by a prolongation

of the cover on the lamp mechanism. When crocus cloth is used, the rod should always be wiped with a piece of clean cotton waste, before the rod is pushed up into the lamp.

The feeding mechanism is usually supported on the upper part of the lamp frame. In the case of most lamps the frame is provided with two suspension hooks which are generally in electrical connection with the positive and negative terminals of the circuit, but insulated from the main body of the frame. The suspension hooks are generally furnished with binding post attachments, in order to ensure a more intimate contact with the circuit wires than could be secured by mere hanging.

One of the commonest forms of arc lamp suspension is that in which the weight of

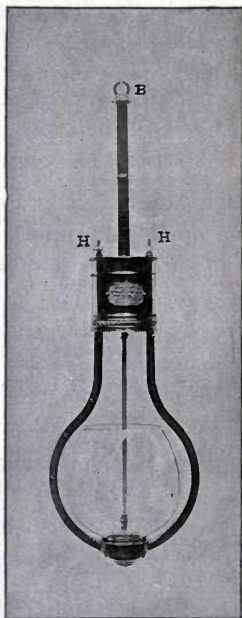

FIG. 48.—FORM OF ARC LAMP SUSPENSION.

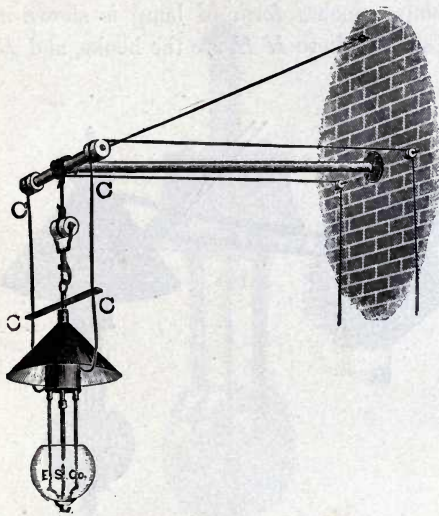

FIG. 49.—OUTRIGGER SUSPENSION.

the lamp is not permitted to be sustained by the hooks, but is borne by a line connected to an eye-piece, at the top of the

lamp. Such a form of lamp is shown in Fig. 48, where *H H*, are the hooks, and *B*,

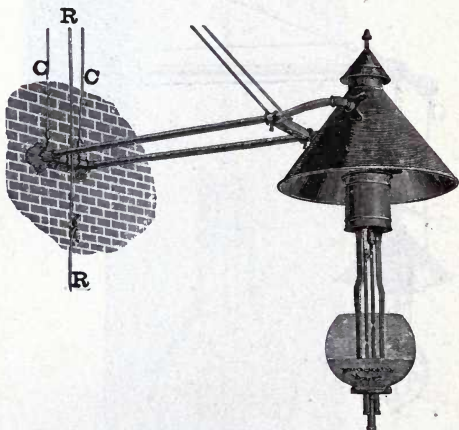

FIG. 50.—OUTRIGGER AND HOOD.

is the supporting eye-bolt. Fig. 49, shows a lamp suspended in this way from an



FIG. 51.—HOOD SUSPENSION.

outrigger attached to a wall. Here the conductors $C C, C C$, keep the lamp from spinning around the supporting rope. If, however, the lamp is suspended by its upper ring from a fixed hook this rotation becomes impossible.

Fig. 50, shows a different form of outrigger support, in which an iron frame is substituted for the rope. The lamp can be lowered by the rope $R R$ for trimming. The conductors $C C$, enter the hood by the frame.

Fig. 51, shows a form of lamp where the suspension hooks are attached to the hood.

Fig. 52, represents a form of suspension in which the lamp is held from a hanger board by two rods connected directly with the suspension hooks.

Fig. 53, represents a form of adjustable lamp hanger in which the lamp is sup-

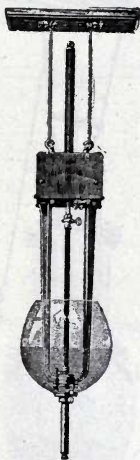

FIG. 52.—LAMP AND HANGER BOARD.

ported by rope attached to the suspension hooks. The form of attachment shown is

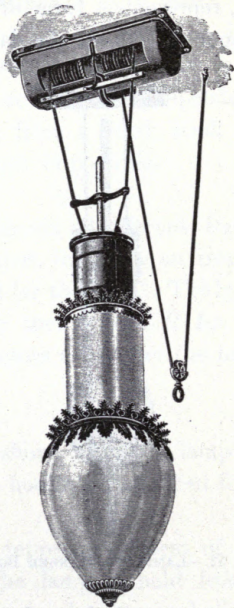

FIG. 53.—ADJUSTABLE LAMP HANGER, WITH AUTO-
MATIC SWITCH.

also provided with an automatic switch so arranged that when the lamp is lowered for purposes of trimming or re-carboning, it is automatically removed from the circuit,

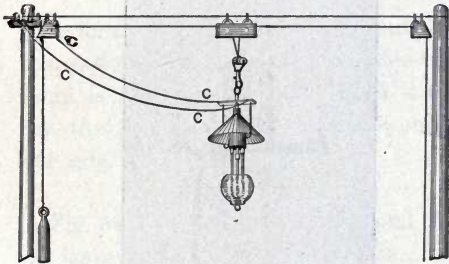

FIG. 54.—CROSS-WIRE SUSPENSION.

thus preventing the possibility of danger to the trimmer.

Fig. 54, shows a form of cross-wire suspension for arc-lamps. By means of a twin-pulley and cord, attached as shown, the lamp is raised and lowered at will. *CC*,

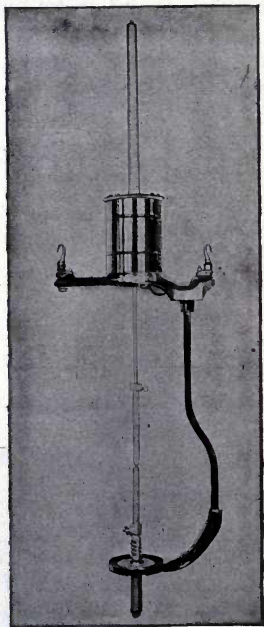

FIG. 55.—SIDE FRAME LAMP.

CC, are the conducting wires. An inspection of the figure will show that when the weight on the left is raised, the lamp is lowered.

A form of lamp suitable for cross-wire suspension, commonly called a side-frame lamp, is shown in Fig. 55. Such a lamp can throw a shadow of its frame only on one side.

Fig. 56, represents an ornamental form of lamp suitable for indoor use. This lamp is secured to the ceiling of a hall or room. The connecting wires are shown at the top.

The simplest method of hanging a lamp from a cross wire, is to support it from the wire, connecting the wire to the lamp terminals on each side. The span wire is then



FIG. 56.—INDOOR LAMP FOR CEILING SUSPENSION.

cut and the ends connected through an insulator, called a *circuit-loop break-insulator*. Several forms of these insulators are shown in Figs. 57 and 58. The circuit would

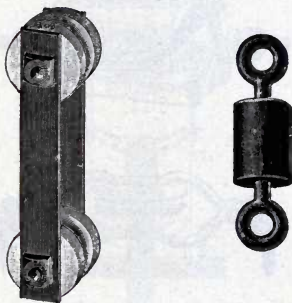

FIG. 57.—CIRCUIT-LOOP INSULATORS.

evidently be open entirely at the insulator if the lamp, connected as a shunt, did not permit the current to pass from one side to the other.

A very common form of support for arc lamps in street lighting is the pole support. Many forms of pole supports have been

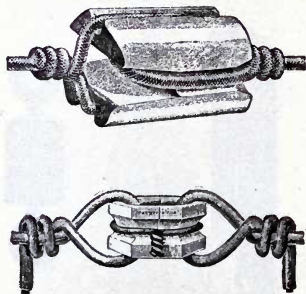

FIG. 58.—CIRCUIT-LOOP INSULATORS.

devised. One of the simplest forms of single-lamp pole support is shown in Fig. 59. A cross-arm bearing two insulators, *II*, carries the conducting wires *CC*, through the vertical frame supported on



FIG. 59.—POLE SUPPORT.

a cast-iron bracket, placed at the top of the poles. The hood and the lamp are supported on the top of this frame as shown.

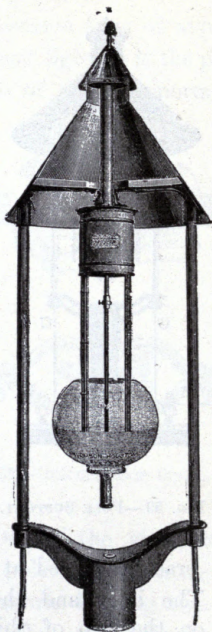

FIG. 60.—IRON POLE SUPPORT.

A similar form of pole support is shown in Fig. 60, where the hood is seen in section, and the lamp is supported from a device called a *hanger board*, placed inside the hood.

Pole lamps of the character represented in Figs. 59 and 60, being provided with no means for lowering, require the trimmer to climb the pole for re-carboning. The poles are, therefore, usually provided with fixed steps shown on the right hand side of Fig. 61, whereas the pole seen on the left hand side of the same figure has to be reached by means of a ladder. Other forms of ornamental, cast-iron poles, for use in cities, are shown in Fig. 62.

In order to avoid the necessity of climbing the pole or of carrying a ladder in trimming lamps, pole lamps are frequently

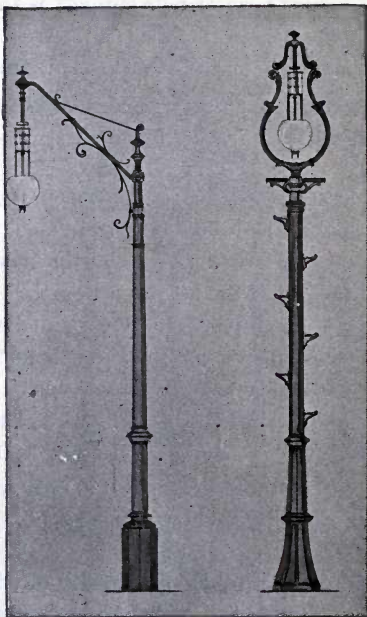

FIG. 61.—ORNAMENTAL POLES.

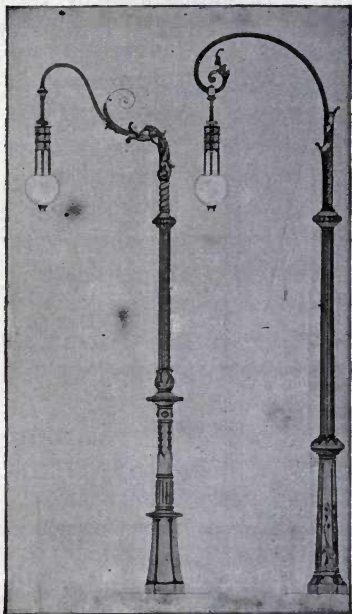

FIG. 62.—ORNAMENTAL POLES.

provided with means whereby the lamp may be lowered. In the device shown in

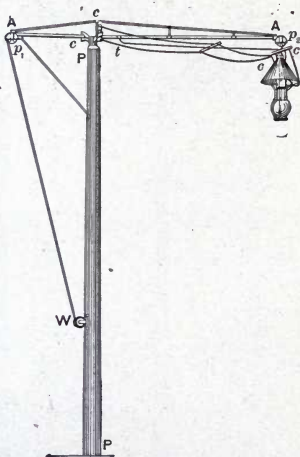

FIG. 63.—MAST-ARM SUPPORT. LAMP RAISED.

Fig. 63, a mast arm *A A*, is rigidly supported at the top of the pole *P P*. A flexible rope, wound on the wheel *W*,

passes through the pulleys $p_1 p_2$. An eye-bolt, on the top of the lamp hood, is

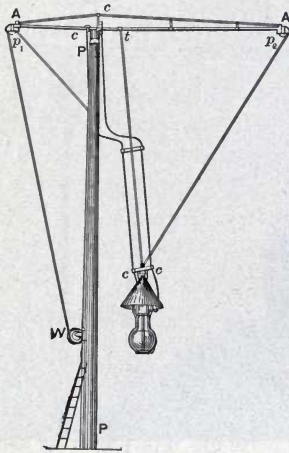

FIG. 64.—MAST-ARM SUPPORT. LAMP LOWERED.

fastened to the mast arm at the point t . The conductors c, c , reach the lamp as shown. When it is desired to lower the

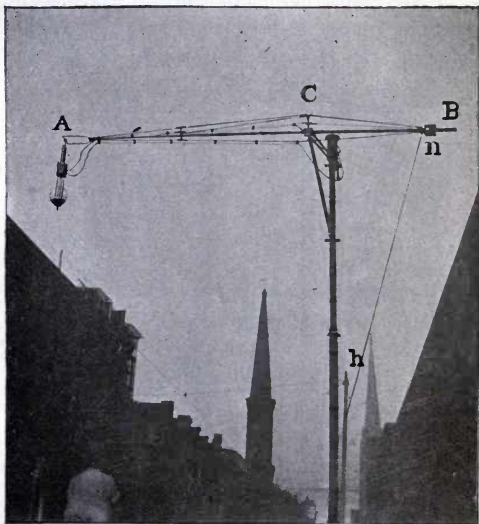

FIG. 65.—ARC LAMP MAST ARM.

lamp, as in Fig. 64, a wheel *W*, placed for safety at such a height above the ground as will require a ladder to reach it, is

turned, allowing the lamp to assume the position shown.

In Fig. 65, the mast arm $A B$, is movable about the horizontal axis C . The lamp end of the arm is slightly the heavier, although partly compensated by the counterpoise at B . The arm is supported in a horizontal position, however, by the chain $h n$, so that, when this chain is released, the lamp A , is lowered to within such a distance of the ground as enables it to be reached by the trimmer when mounted on a short ladder.

For the illumination of extended open areas such as parks and squares, arc-lamp towers are sometimes employed. One of these is represented in Fig. 66. It consists, as shown, of a light steel structure about 150 feet high, carrying a platform

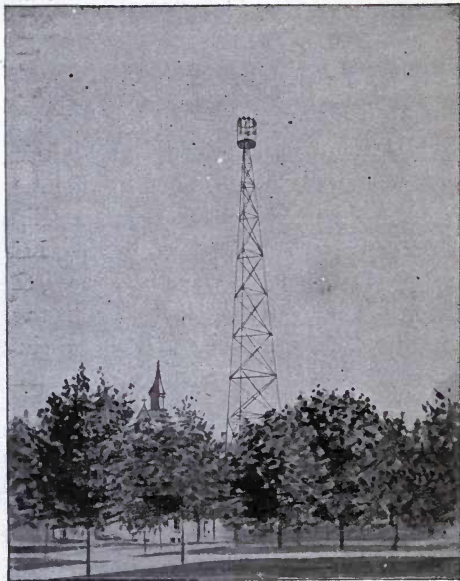

FIG. 66.—ELECTRIC ARC LIGHT TOWER.

at its summit, with hangers for a crown of six 2,000 candle-power arc lamps. The illumination effected by tower lighting more nearly resembles moonlight than that obtained from any other artificial source.

Suspended arc-lamps are generally employed in connection with devices called *lamp hangers*. A lamp hanger is a plate, or board, from which the lamp is suspended, and on which the electrical connections are placed, generally in plain view, so that the lamp can readily be either completely short-circuited, or completely removed from the circuit, as may be desired.

Fig. 67, shows two forms of stationary lamp hangers. *C, C*, are conducting clamps from which the lamp is supported by rods. A metallic strip *H, H*, furnished with a non-conducting handle, serves as a switch

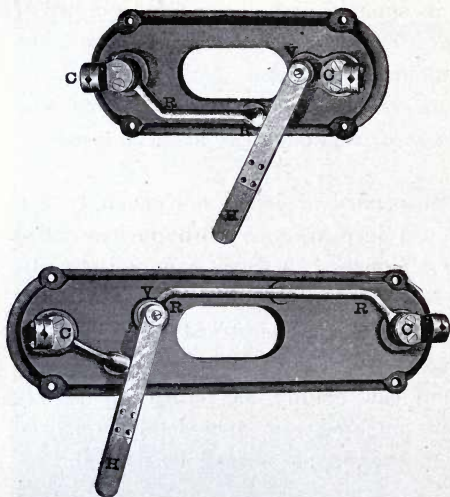

FIG. 67.—LAMP HANGERS.

for the purpose of short circuiting the lamp when in the position shown, through the rod *R, R*.

A circular form of short-circuit hanger and switch is represented in Fig. 68 suitable for conical lamp hoods.

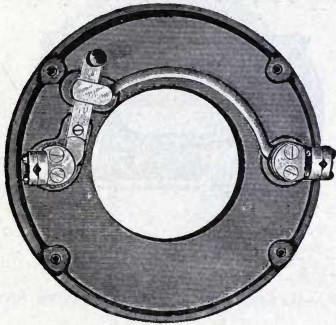

FIG. 68.—CIRCULAR LAMP HANGER.

Fig. 69, shows a form of *hanger board* provided with a switch, that, unlike the switches shown in Figs. 67 and 68, instead of merely short circuiting the lamp, also completely insulates it from the circuit, so

that there is no danger in handling the lamp so cut out. Two metallic strips S, S , furnished with insulating pieces at their extremities X, X , are connected by a strip

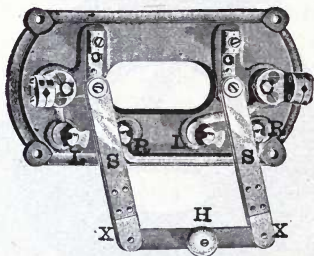

FIG. 69.—HANGER BOARD AND INSULATING SWITCH.

provided with a handle or knob H . When the handle is turned to the right and placed in the position shown, the circuit is completed between the binding posts c, c , through the metallic rod connecting the clips R, R . When, however, the switch is turned to the left, the circuit is closed

through the lamp and its conducting rods clamped in C, C , by the strips and the clips L, L .

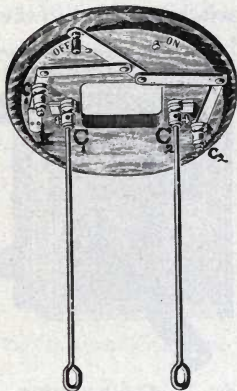

FIG. 70.—CIRCULAR INSULATING HANGER BOARD AND SWITCH.

Fig. 70, represents another form of circular insulating hanger board. With the switch in the position shown, the circuit is

closed directly through c_1 , the clip k , and a rod at the back of the board to c_2 , thus cutting the lamp out of circuit; while, when the switch is turned to the right, the

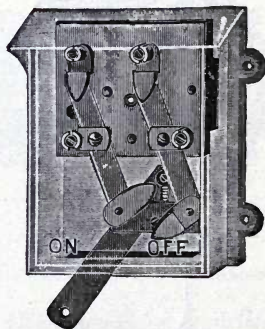

FIG. 71.—CUT-OUT SWITCH.

connections are made from c_1 to C_1 , through the lamp and from C_2 to c_2 .

Figs. 71, 72, and 73, show forms of cut-out switches which are not connected to a

hanger board, but are placed on some convenient support such as a wall or post. In all of these devices, the cutting out is effected by means of a lever or handle, the position of which, marked



FIG. 72.—CUT-OUT SWITCH.

“on,” or “off,” determines whether the circuit is completed through the lamp or through the short circuit.

Fig. 74, shows the exterior and 75, the interior view of an arc-lamp cut out,

arranged so as to be operated by an up and down motion of the hook *H*. In the figures, the hook is shown pushed up as far

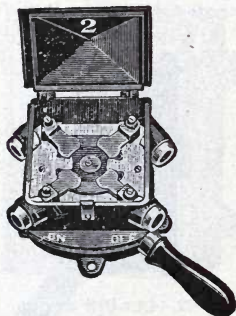

FIG. 73.—CUT-OUT SWITCH.

as it will go, corresponding to the position in which the current passes through the lamp, entering by the connections *a b c d*, and leaving by the connections *e f g h*, *a* and *h*, being the line wires, and *d* and *e*,

the leads to the lamps. On the pulling down of the lever, the lamp is cut out from the circuit. When the hook *H* is

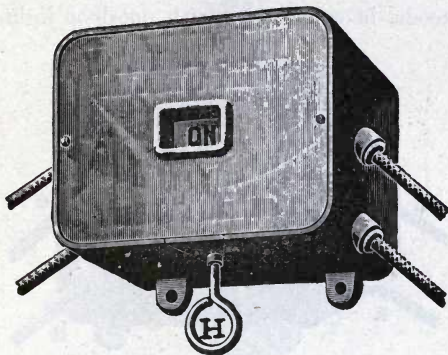

FIG. 74.—CUT-OUT SWITCH.

pulled down, the levers *b* and *g*, are forced together at their upper ends into clips in the centre of the box, thus short-circuiting the apparatus, and leaving the lamp by its

clips *c* and *f*, totally disconnected from the circuit.

We have already referred to the use of hoods, in connection with out-door light-

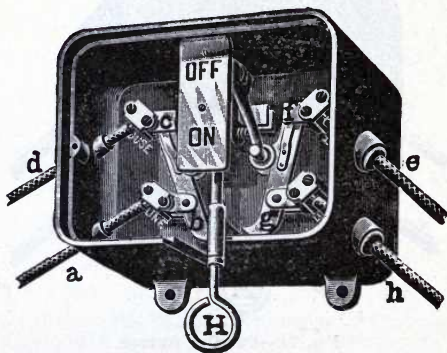

FIG. 75.—CUT-OUT SWITCH.

ing, for the double purposes of protecting the lamp and of throwing its light downwards. Some forms of *lamp hoods* are

shown in the accompanying figures 76 to 81, from which it will be seen that a variety of

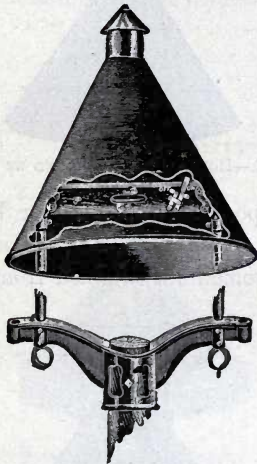

FIG. 76.—HANGER BOARD IN POSITION UNDER HOOD.

forms have been devised. In Fig. 76, a portion of the hood has been cut away to

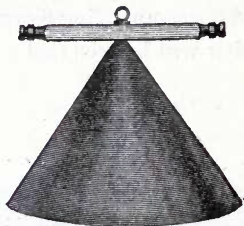

FIG. 77.—HOOD TO BE SUPPORTED BY A ROPE.

show a portion of the hanger board. It will be noticed that the support of the hood is sometimes obtained from ropes, as

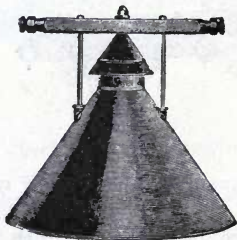

FIG. 78.—HOOD TO BE SUPPORTED BY A ROPE.

in Figs. 77, 78 and 79, while in other cases, the hood is supported on a pole, as in Figs. 76, 80 and 81. The connecting wires



FIG. 79.—HOOD TO BE SUPPORTED BY A ROPE.

dip underneath the hood on their way to the lamp terminals. Fig. 79, shows a switch handle *H*, projecting through the

hood. The hoods are usually made of japanned galvanized iron, so arranged as to aid in the reflection of light downwards.



FIG. 80.—HOOD SUPPORTED ON POLE.

It is necessary, in the operation of arc lamps, to protect the arc from currents of air which tend to increase its unsteadiness.

This is effected by covering the arc with a transparent globe. Such globes are made in a variety of forms, some of which



FIG. 81.—HOOD SUPPORTED ON POLE.

are shown in Fig. 82. An inspection of the figure will show that these are divisible into two sharply marked classes; namely,

those open at both ends, and those open at one end only.

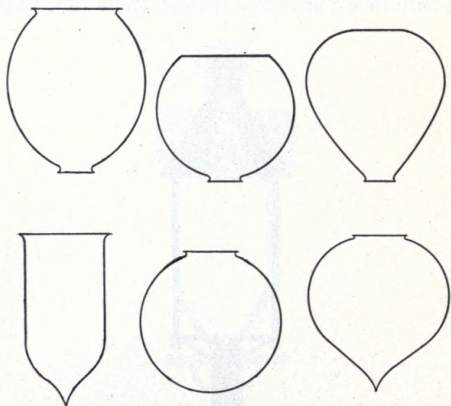

FIG. 82.—FORMS OF ARC LIGHT GLOBES.

Besides protecting the arc from the disturbing effect of the wind, a globe serves a more important purpose. By far the greater part of the light emitted from a

carbon arc comes from the positive crater, and, as this is quite limited in area, the source of illumination is almost a point. An uncovered light would, therefore, necessarily cause marked shadows. By employing a translucent material for the globe, such as porcelain, or opal glass, the entire surface of the globe becomes illuminated, and thus distributes the light more uniformly. Measurements show that globes absorb from forty to sixty per cent. of the light passing through them. In some globes, even a greater percentage is lost. Since a comparatively small quantity of dust on a globe will greatly add to the loss of light by absorption, it is desirable that the globes be frequently cleaned.

For the protection of the globes, and also to avoid accidents from falling glass, a netting of thin galvanized iron wire is

frequently placed over the globe as shown in Fig. 83. The globe may be placed either outside the frame or inside, as shown in Figs. 25 and 84. This is not entirely a matter of choice, since the shadows may



FIG. 83.—GALVANIZED IRON WIRE GLOBE NETTING.

be more marked with the frame on the outside than on the inside of the globe.

Globes are often partly transparent and partly translucent. This division of the globe is also sometimes effected in the vertical, instead of in the horizontal plane.

Where arc lamps are used in locations where they are surrounded by inflammable

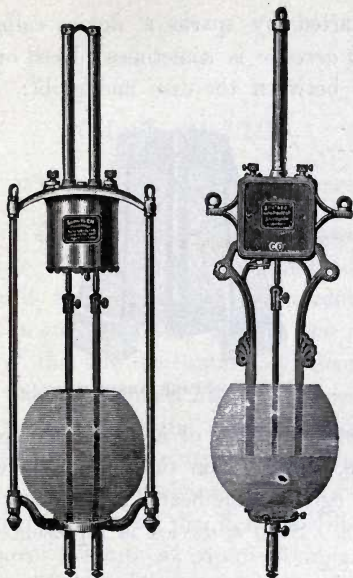

FIG. 84.—GLOBE INSIDE AND OUTSIDE OF LAMP FRAME.

material, as in the interior of highly decorated shop windows, where fires might

be started by sparks, a device called a *spark arrester* is sometimes placed on the lamp between the case and globe. This



FIG. 85.—SPARK ARRESTER.

consists essentially of a conical wire-gauze screen, supported on the globe, and which gives egress to the heated air, but stops all sparks. Such a device is represented in Fig. 85.

CHAPTER VIII.

ALTERNATING-CURRENT ARC LAMPS.

THE alternating-current arc possesses a number of characteristics which distinguish it from the continuous-current arc. Since in an alternating current the direction of the flow is continually changing, each carbon becomes alternately positive and negative. In the alternating-current arc, therefore, no positive crater and opposing negative nipple are formed, so that the distribution of the light is different. Moreover the rate of consumption of the carbons is, approximately, equal.

The influence of frequency is considerable upon alternating-current arcs. Below

a frequency of about 35 periods, or double reversals per second, the arc distinctly flickers, and produces an unpleasantly varying visual effect, owing to its rapid alternating production and extinction at each pulsation of current. Above a frequency of 70 cycles, or double reversals per second, alternating-current arcs develop a tendency to produce a distinct humming note, which, at higher frequencies, becomes disagreeable. A frequency of about 60 cycles, or 120 reversals per second, is generally regarded as the most suitable.

An alternating-current arc lamp does not require to be supplied with a pressure, as indicated by a voltmeter, as high as the 40 or 50 volts required in the continuous-current arc lamp; the pressure it requires is but from 30 to 35 volts. An alternating pressure, of say 35 volts, represents a

maximum pressure in each wave of about 50 volts. In other words, if we employ an alternating E. M. F. which rises to 50 volts at the peak of each wave, then during the rapid reversals of pressure which necessarily attend alternating currents, the effective E. M. F. will be about 35 volts, but will depend for its exact value upon the shape of the wave. Consequently, the E. M. F. required to maintain the alternating-current arc, is, in reality, the same as that in the continuous-current arc, but the voltmeter only represents the effective or mean and not the maximum pressure. The current strength required for an alternating-current arc may have a wide range of variation, just as in the case of the continuous-current arc, but a common value is 15 amperes, so that the activity of an arc, taking 15 amperes at a pressure of 30 volts, may be

450 watts; or that which corresponds nominally to a 2,000 candle-power continuous-current arc lamp, when supplied with 45 volts.

Like continuous-current arcs, alternating-current arcs require a lamp mechanism in order to maintain the carbons at a constant distance apart. The rate of consumption of the two carbons being, however, generally nearly equal, the character and design of the mechanism has to be considerably modified, especially when we remember that alternating currents instead of continuous currents pass through the lamp.

It is a well known fact that when an electric-current passes through a coil of insulated wire, it develops magnetic properties in the coil, the polarity of which depends upon the direction of the current. It might be supposed, that since in the

case of an alternating current, the polarity necessarily changes with each alternation, that an electromagnet, whose coils were traversed by alternating currents, would possess no definite polarity, or would exert no continued attraction on an armature or core of soft iron. Such, however, is not the case. An alternating-current electromagnet does exert an attraction on an armature or core, as in the case of a continuous-current magnet, although the amount of attractive force differs in many respects from that exerted under the same conditions by a continuous current. Consequently, electromagnets are capable of being employed in alternating-current lamp mechanisms for maintaining the arc.

A form of alternating-current arc-lamp mechanism is shown in Fig. 86. $T, T,$ are the terminals which are connected to the

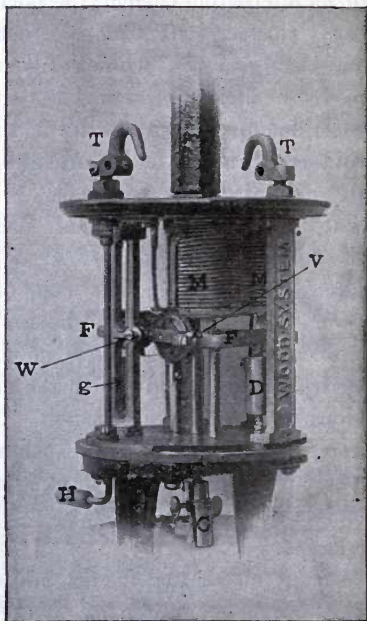

FIG. 86 —ALTERNATING-CURRENT LAMP MECHANISM.

magnet coils, M, M . The cores of these magnet coils are attached to the frame $F'F'$, pivoted on the line of the screw W , in such a manner that when the magnets are powerfully excited, the frame $F'F'$ is raised on the right-hand side by the armature cores, and the lamp rod with its carbon is also raised through a rack and pinion, thus establishing an arc. When the arc becomes too long, thereby weakening the attraction of the magnets M, M , the armature core permits the frame to be lowered, thereby releasing the wheel work by which the carbon is lowered through its own weight. D , is a *dash-pot* or *damping-vessel*, provided to check sudden oscillations; H , a switch handle for cutting out the lamp; C , is the upper carbon holder.

Fig. 87, represents diagrammatically the connections of the preceding lamp. T, T ,

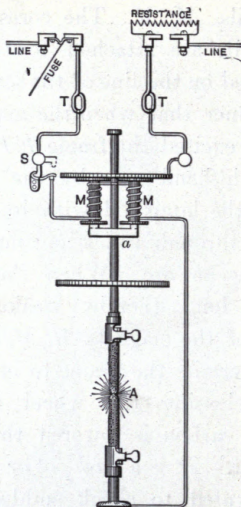

FIG. 87.—CONNECTIONS OF LAMP MECHANISM SHOWN IN FIG. 86.

are the terminals; *S*, the switch; *M*, *M*, the magnet coils; *a*, the armature. The arc is established at *A*. A resistance is in-

serted between the line and the lamp on one side, and a safety fuse on the other side, to protect the lamp from any accidental strong current. It will be observed that this mechanism employs no shunt winding. This is rendered unnecessary since these lamps are never connected in a series circuit. They are always connected to a source of practically constant pressure, like the constant-potential continuous-current arc lamps.

Unlike continuous-current lamps, alternating-current lamps are never directly connected with the mains of the generator supplying alternating currents, but always through the intervention of an apparatus called an *alternating-current transformer*; that is to say, the alternating-current generator, or *alternator*, supplies in its circuit devices which are called transformers, and

each of these transformers, in its local circuit, supplies alternating-current incandescent, or alternating-current arc lamps, or both. Each transformer is, therefore, provided with a *primary* and a *secondary circuit*. The primary circuit is connected directly with the generator, usually at a comparatively high pressure, 1,000 or 2,000 volts being very common. The secondary circuit is connected with the local arc or incandescent lamp circuit, usually at a pressure of about 100 volts. If only a single lamp has to be supplied, the secondary circuit is arranged to give about 33 volts only, while, if incandescent lamps have to be supplied, the secondary coil of the transformer has to generate a pressure of about 100 volts, so that some device, such as either a *resistance*, or a *choking coil*, must be introduced into the circuit of the arc lamps in order to keep this pres-

sure down to 30 volts. A single arc transformer is represented in Fig. 88. Here, the



FIG. 88.—ALTERNATING-CURRENT LAMP AND CIRCUIT CONNECTIONS.

transformer T , has its primary wires p, p , connected to the primary circuit at a pressure of, perhaps, 1,000 volts alternating, while the secondary wires s, s , are led

directly to the alternating-current arc lamp *A*.

Fig. 89, represents the introduction of a meter into the secondary circuit, for the

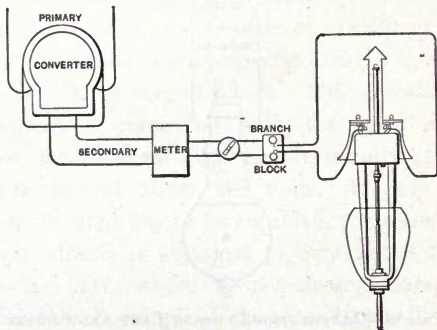

FIG. 89.—ALTERNATING-CURRENT ARC LAMP AND CIRCUIT CONNECTIONS.

purpose of determining the number of hours the lamp has been used and of basing the charge upon the same.

Fig. 90, represents the case in which secondary mains s, s , are supplied by the

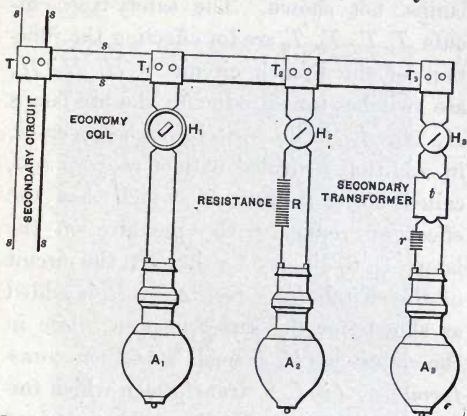

FIG. 90.—VARIOUS METHODS OF CONNECTING ALTERNATING-CURRENT ARC LAMPS.

secondary coil of a transformer with an alternating-current pressure of 50 or 100 volts, such as would be suitable for incandescent lamps. Each of these mains is

alternately positive and negative, and across them are connected incandescent lamps, not shown. The safety-fuse cut-outs T, T_1, T_2, T_3 are for effecting the junction of the branch circuits. H_1, H_2, H_3 , are switches for introducing the arc lamps A_1, A_2, A_3 . The switch H_1 however, is, in addition, provided with a *choking coil*, called an *economy coil*, which has the effect of reducing the pressure on the lamp A_1 , to about 33 volts. In the circuit of the switch H_2 , a resistance R , is added as shown, for the same purpose, while in the circuit of H_3 , a small *step-down transformer* t ; (*i. e.*, a transformer which furnishes a lower E. M. F. at its secondary terminals than is applied to its primary terminals), is employed, whose primary is operated at 50 or 100 volts pressure, and whose secondary supplies about 35 volts pressure. A small resistance r , is inserted in

the secondary circuit, to keep the pressure at the terminals of the lamp A_3 , at about 33 volts.

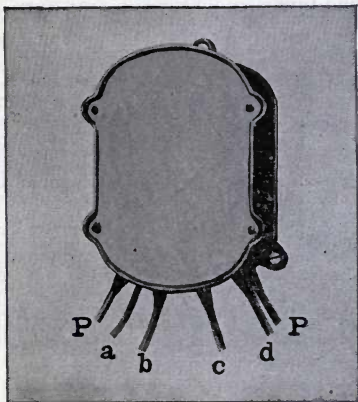

FIG. 91.—ECONOMY COIL FOR USE ON 100-VOLT CIRCUITS.

Of the three methods above described, the first is usually preferable, that is to say the economy coil is the simplest and

the least expensive as regards energy, since a resistance, such as R , consumes a considerable amount of energy in effecting the same purpose, while the transformer t , requires both a primary and a secondary coil.

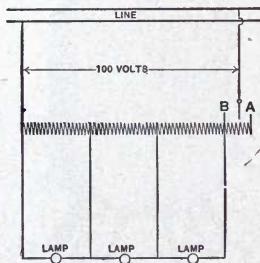

FIG. 92.—CONNECTIONS OF ECONOMY COIL.

The economy coil, which is in fact a *choking coil*, requires, as a rule, only a single circuit. A form of economy coil, suitable for use with one, two, or three arc lamps connected with 100-volt alternating mains,

is shown in Fig. 91. P, P , are the wires connected to the 100-volt mains. The lamps are inserted between a and b , be-

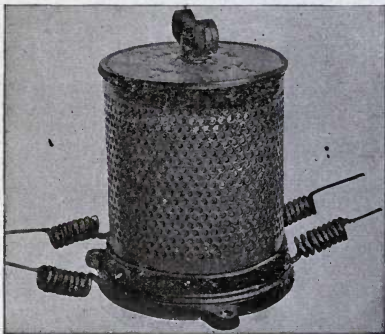

FIG. 93.—ECONOMY COIL AND SWITCH.

tween b and c , and between c and d . The connections of this coil are shown in Fig. 92.

Fig. 93, represents a form of economy coil intended for a single lamp when sup-

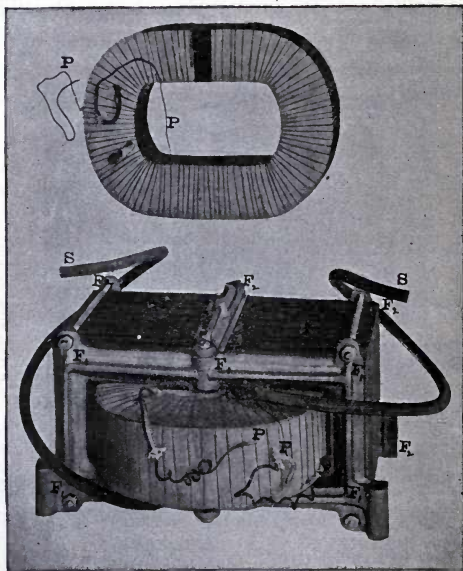

FIG. 94.—TRANSFORMER, DETAILS OF CONSTRUCTION.

plied from 100-volt mains. The switch handle is represented as placed on the cover.

Fig. 94, represents a form of transformer suitable for supplying a secondary arc-light circuit, from a high-pressure alternating-current primary circuit. Two cast iron frames $F_1 F_1 F_1$, and $F_2 F_2 F_2$ are tightly clamped together, and press between them a *laminated core*; *i. e.*, a number of sheets of soft iron I, I , all lying parallel to the frame. These sheets are so arranged as to pass over the ends, and also through the centre, of two coils of wire, carefully insulated from the frame and from each other. Their ends are marked P, P , and S, S , respectively. The primary coil P, P , is also shown separately in the upper part of the figure. It consists of many turns of fine wire, while the second-

ary circuit consists of comparatively few turns of coarse wire. When the wires P ,

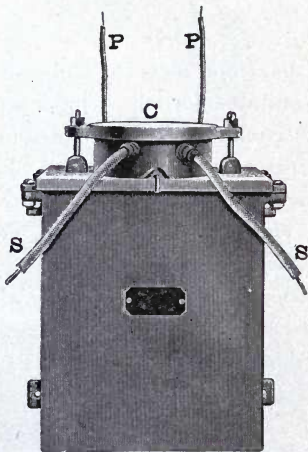

FIG. 95.—OIL INSULATED TRANSFORMER.

P , are connected to an alternating pressure, of say 1,000 volts, the secondary wires S , S , will deliver an alternating

pressure, of say 25 volts. The frequency remains the same in both circuits, but the current strength is much greater in the secondary, than in the primary circuit. Such transformers are frequently encased in an iron box or shell with or without an insulating oil. A form of shell, suitable for holding an *oil-insulated transformer*, is represented in Fig. 95. Here the wires *P, P*, pass through beneath the cover to the primary coil, and the wires *S, S*, similarly pass to the secondary coil. The cover *C*, is clamped in position by screws, on each side, in such a manner that, when oil has been filled-in, none can escape during shipment.

Fig. 96, represents a form of 15-ampere, 30-volt, alternating-current arc lamp, and Fig. 97, represents the same lamp with its globe removed and inverted for trimming



FIG. 96.—ALTERNATING-CURRENT CONSTANT-POTENTIAL
LAMP.

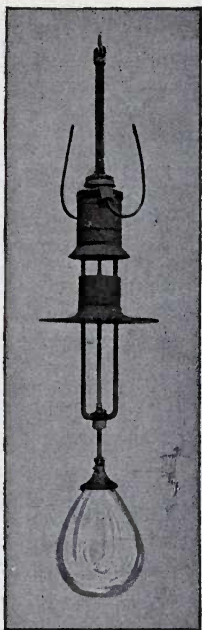

FIG. 97.—ALTERNATING-CURRENT CONSTANT-POTENTIAL LAMP WITH GLOBE INVERTED.

carbons. Other forms of alternating-current arc lamps are shown in Figs. 98, 99, and 100.

Since the use of transformers permits the use of high-pressure currents in the primary circuit, it is evident that alternating-current arc lamps, like continuous-current series arc lamps, can be economically used at great distances, since the wire in the primary circuit may be of small dimensions.

In some cases the primaries of the arc-light transformers are connected in the primary circuit in series, while in others they are connected in parallel; the former case is preferable for circuits employed exclusively for arc lamps; the latter case for circuits which are essentially incandescent circuits with occasional arc lights.

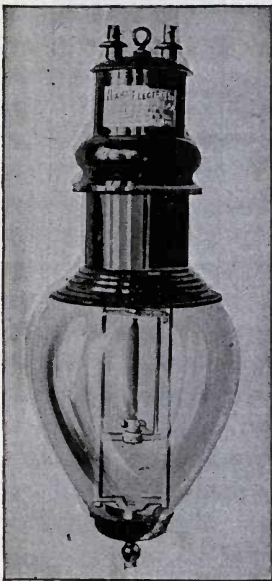

FIG. 98.—ALTERNATING-CURRENT ARC LAMP.

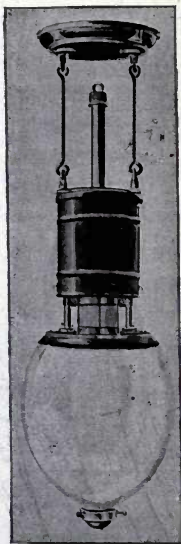

FIG. 99.—ALTERNATING-CURRENT ARC LAMP.

For long-distance, scattered arc lighting, a high-tension system is absolutely

necessary for the sake of economy in conductors. Such a system may be either a

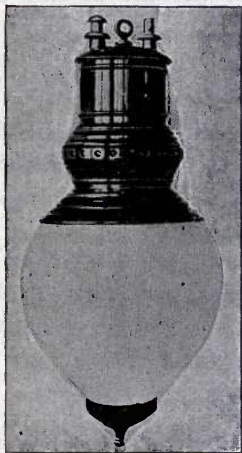

FIG 100 —ALTERNATING-CURRENT ARC LAMP.

series continuous-current system, or an alternating-current system. A series con-

tinuous-current system, has, however, the advantage of not requiring the interposition of a transformer at each arc lamp. The use of constant-potential lamps, either of the continuous or alternating-current type, is very convenient where a constant-potential system is already installed, for the purpose of incandescent lighting or for power transmission.

CHAPTER IX.

LIGHT AND ILLUMINATION.

HAVING obtained some insight into the general nature of the arc, and of the various mechanisms employed in its commercial use, it now remains to examine the nature of the light emitted, and the means employed for determining its intensity and illuminating power.

The word *light* is used in two distinct senses; namely, objectively, as the cause producing the sensation; and subjectively, as the physiological sensation produced in the mind through the intervention of the eye. Objectively, that is, as it exists outside of us, independently of the eye,

light consists of oscillatory motions, or to-and-fro vibrations in the universal ether. The glowing carbon in the voltaic arc, as well as the seething mass of carbon vapor in the arc proper, impart wave motions to the ether surrounding them, which wave motions are propagated in what are known physically as rays of light.

Without attempting to discuss at length the character and properties of the universal ether, it is sufficient to state that it is now generally believed by scientific men, that not only the otherwise empty space existing between the sun and the distant stars, but even that space which is apparently filled by gross matter, is pervaded by an extremely tenuous, but highly elastic medium called the ether. In gross matter the ether fills the space between its

ultimate particles; or as they are called the *atoms* and the *molecules*. When a candle is lighted, or an electric arc turned on, the light produced is transmitted to the observer and to surrounding bodies by means of a wave disturbance set up by the activity in the candle, or in the arc. If, for the purposes of discussion, we imagine the universal ether to be represented by a fluid, such as air, then light might be considered in its passage through such air as being due to oscillations of the air particles. These oscillations will take place in a direction at right angles to the direction in which the waves of light are moving, so that in any ray of light we have to imagine the ether particles as vibrating to-and-fro across the ray.

The rapidity with which the ether vibrations take place, or, as it is generally called,

the *frequency of vibration*, is in all cases enormously great, and varies between wide limits. The limits of these frequencies is not known, but physiologically only those frequencies lying between 390,000,000,000,000 and 760,000,000,000,000 per second, are appreciated by the eye as light. Frequencies above 760 trillions, consist of what is sometimes called *ultra-violet light*, and produce no effect on the eye. Similarly, frequencies below 390 trillions, are called *infra-red frequencies*, and likewise produce no effect on the eye; but all frequencies, whether able to excite the eye physiologically or not, are capable of affecting our senses in a greater or less degree as heat.

It may, at first sight, appear inconsistent to thus speak of the existence of what might be called *dark light*, but in the physical sense, in contradistinction to the phys-

iological sense, such an expression is perfectly proper. Besides affecting the eye physiologically in the sensation of light, and producing the phenomena of heat, the ether waves also possess the power of effecting chemical decomposition in many substances. This chemical power of light is known as its *actinic power*, and is utilized in photography. It is the actinic power of light which enables the growing plant to abstract, from the carbonic acid of the air, the carbon required for its woody fibre.

The frequency of vibration within the visible range determines the *color* of light; the lowest frequencies; *i. e.*, about 390 trillions per second, produce the reds, and the highest, or 760 trillions, the violets. Intermediate frequencies produce the oranges, the yellows, the greens and the blues.

In free space, light is propagated at a velocity which various measurements show to be, approximately, 186,000 miles per second. In free space, so far as known, this velocity is the same for all colors of light; *i. e.*, for light of all frequencies. When, however, light travels through the ether that fills the inter-atomic and inter-molecular spaces of transparent substances, such as glass, the velocity is not only reduced, but is reduced differently for different frequencies; high frequencies being generally reduced more than low frequencies. Consequently, when a *beam* of sunlight; *i. e.*, a collection of parallel rays, is allowed to fall on a prism, this difference of velocity in the different colored rays through the prism results in the decomposition of the light into colored rays, which, when projected on a screen, produce a rainbow-colored band called a *spectrum*. Evidently

all these colors exist in sunlight, and it is to their presence that the color of various bodies is due. When sunlight falls on differently colored objects, certain of the colors are absorbed, and the remainder being given off by the surfaces, produce through the agency of the eye a sensation which is called the color of the body. Clearly then it is impossible for a body to emit its true daylight colors when placed in any light, unless the light by which it is illumined contains the particular colors it gives off when illumined by sunlight, and moreover contains the same relative proportions of such colors, as does sunlight.

In the above connection it is, therefore, necessary to note that the function of any artificial light may be regarded from two distinct standpoints; namely, in the ability

of light to enable the form of bodies to be distinguished, and secondly in its ability to enable colors to be distinguished. For example, nearly all sources of artificial light contain certain proportions of practically all the colors of the spectrum, in other words, contain all frequencies of vibration within the physiological limits, but some of these colors or frequencies are present in such relatively small quantities as to be practically absent. Consequently, the light received from any of these sources, while competent to render the outlines of bodies visible, may not be able properly to give them their *sunlight* or *daylight color values*. For example, an artificial light deficient in the blues, while competent to distinguish both the outline and color of red and yellow objects, would only be able to distinguish the outlines, and not the true colors, of blue objects.

We have spoken of light as being, objectively, due to vibrations set up in the ether, but it may be remarked, in passing, that these vibrations are now generally believed to be of an electromagnetic nature in their mechanism, that is to say that the vibrational activity in the ether is both electric and magnetic.

Accompanying the light which is physiologically able to produce visual sensations, there is much non-visual light, or light which is only able to produce thermal or chemical effects. The value, therefore, of any artificial illuminant will necessarily depend upon the relation existing between the visually effective and the visually ineffective portions of illumination; for, since energy must be expended to produce light, more energy will be required according as the light is deficient in visually effective

rays. The ratio of the radiant energy, which is visually effective, to the total radiant energy emitted by any given source of light, is called its *luminous efficiency*. The following are the luminous efficiencies of certain sources according to Nichols :

LIST.

Arc lamp, 9 amperes at 45 volts.....	0.133
Incandescent electric lamp, 16 candle-power at 50 volts, and about 50 watts.....	0.05
Magnesium light.....	0.135
Drummond lime light, initial value.....	0.14
Steady value after 30 mins.....	0.086
Argand gas burner.....	0.012 to 0.024
Petroleum flame.....	0.02
Candle flame.....	0.015
Yellow-light Auer incandescent mantle, at 3 c. ft. per hour.....	0.019
At 5 1/2 c. ft. per hour.....	0.028

It will thus be seen that the luminous efficiency of the arc lamp is practically as high as that of any known artificial source, being about 13 1/3 per cent., while it is

nearly three times greater than that of the normal incandescent electric filament and about six times greater than that of oil or gas flames.

The presence of heat in an artificial illuminant not only has the effect of increasing the cost of producing the light, but it is also objectionable from the fact that it increases the temperature of the surrounding air in the case of interior illumination.

It has been found that the luminous efficiency of the light emitted by the firefly is practically one hundred per cent. or, in other words, that the firefly does not seem to emit any frequency of light vibration which is not within the limits of visibility. At the present time, in order to produce artificial light, we require to

raise the temperature of the luminous body to such a point that the rapidity or frequency of oscillation of its molecules shall enable them to emit light, as well as heat. But, unfortunately, this results in the production of much more dark heat than luminous heat. It remains, therefore, to discover some means for producing visible frequencies, unaccompanied by invisible frequencies.

Unfortunately we possess at the present time no unit either of physical or of physiological light. We do possess, however, various *standard sources* of light the intensity of whose light is taken as standard, or, as unity.

A few of such standards are as follows :

- (1) The *British Standard Sperm Candle*, burning at the rate of 2 grains per minute.

(2) The *Vernon-Harcourt Pentane Standard*, in which a gas flame of a given height, observed through an opening of definite size, consumes pentane, a variety of coal oil.

(3) The *Carcel Colza-Oil Lamp*, burning 42 grammes of pure colza oil per hour, at a flame height of 40 millimetres.

(4) The *Hefner-Alteneck Amyl-Acetate Lamp*, in which the flame stands at an elevation of 40 millimetres.

(5) The *Violle Standard Platinum Lamp*, in which the standard light is emitted from one square centimetre of platinum at the temperature of solidification.

(6) The *Reichsanstalt Standard*, or the light emitted from a square centimetre of platinum at a definite high temperature.

When we speak of a *unit of light* we mean that this unit light, concentrated

at a point, would produce unit illumination at unit distance from this point. For example, if we select a standard candle as our unit of intensity of light,

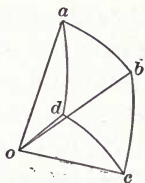

FIG. 101.—UNIT ILLUMINATION PRODUCED AT UNIT DISTANCE FROM UNIT LIGHT SOURCE.

and suppose the flame concentrated at a point, then at one metre distance from this point in any direction we should have *unit illumination*. In other words, the total quantity of light, considered as a stream or flux, will be unity over the spherical surface *a b c d*, Fig. 101, one

square metre in area, all portions of whose surface are one metre from the luminous source or point. If we call this *unit of flux of light* one *lumen*, then this square metre of surface will receive one lumen, and the whole sphere of one metre radius, enclosing the luminous source at its centre, will receive 12.566 lumens, because its surface will be 12.566 square metres, or 4×3.1416 . The total quantity of light emitted by the standard source will, therefore, be 12.566 lumens. This total quantity of light must be received by an enclosing surface of any shape, as for example, the walls of a room in which the light is placed, because otherwise light would have to be absorbed during the passage from the luminous source to the walls, so that the total quantity of light emitted by the source, independently of the receiving surface, is 12.566 lumens.

We shall in this book adopt two standard sources of light; namely, the *British standard candle*, because it is most familiar to English readers, and the standard French candle called the *bougie-decimale*, which is defined as being the $\frac{1}{20}$ th part of the Violle, or molten-platinum standard. The British candle is slightly in excess of the bougie decimale in intensity, one British standard candle being about 1.01 bougie-decimales. Some authorities, however, place this ratio as high as 1.3.

The *practical unit of illumination* is the illumination produced by one bougie-decimale, at a distance of one metre, so that if we hold the surface of a book perpendicular to the rays of light streaming from a bougie-decimale, in a room, under such circumstances that the book can

receive no light other than that coming directly from the candle, then the illumination on the page of the book will be one *bougie-metre*, or one *lux*. Sometimes a unit of illumination, called the *candle-foot* is employed, being the illumination produced by a British candle at a distance of a foot. It is evident that this illumination is about 10 times greater than the *lux*; or, in other words, that it would take, roughly, 10 *bougie-decimales*, all collected together in a single point, to produce at a metre the same degree of illumination as one British candle at a distance of a foot. The illumination required for comfortable reading of an ordinary newspaper, is, for the normal eye, about 20 *luxes*, while good illumination for reading is 30 *luxes* and upwards. Full sunlight is about 80,000 *luxes* and full moonlight is about $\frac{1}{8}$ th *lux*. The illumination in a street well lighted by arc

lamps is, perhaps, from 50 luxes near the ground at the foot of the arc lamp pole, to one lux near the ground midway between lamps.

It is evident that, if, in the case of any luminous source, such as a candle, all its light could be compressed into a single point, the illumination it would produce at a given distance would be the same in all directions. This is not the case, however, with all sources of artificial light, since the illumination which they give is not only different in different directions, but is sometimes of necessity entirely absent in certain directions. For example, a candle can give no light below a certain angle of depression, owing to the interception of its light by the opaque body of the candle. Similarly, in the arc lamp, since the positive crater is the principal source of light,

usually supplying eighty-five per cent. of the total number of lumens emitted, the light is necessarily stronger in certain directions than in others. Moreover, the area which is shaded by the negative electrode is necessarily devoid of illumination, and, in regions not directly in the axis of the carbon, the intensity of the light will greatly vary.

If, therefore, we take an arc lamp without a globe, and examine the illumination it produces we shall find that very little intensity of light is produced in regions above the horizontal plane passing through the arc. As we descend below this horizontal plane, the intensity rapidly diminishes, very little light being emitted at an angle below 75° of depression. This condition is represented in Fig. 102, where, at any angle measured above or below the

horizontal plane passing through the centre of the arc, the corresponding intensity of the light is marked off by the radius at this angle. In order to determine the

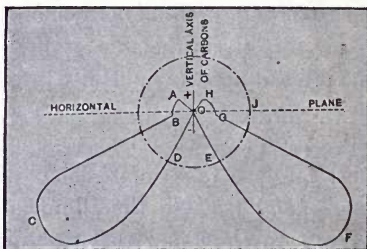

FIG. 102.—DIAGRAM INDICATING LUMINOUS INTENSITY OF A CONTINUOUS-CURRENT ARC LAMP.

mean spherical intensity, we have to measure the intensity in the sphere at all areas above and below the horizontal plane and take their average. If we express the result in bougie decimales, and multiply by

12.566, we obtain the total quantity of light given by the arc lamp in lumens.

It is found, from a number of actual experiments, that roughly the value of the mean spherical intensity is equal to the sum of half the horizontal intensity and one quarter of the maximum intensity.

Thus, if an arc lamp has an intensity of 300 British standard candles in the horizontal plane, and 2,000 British standard candles at the angle of maximum intensity, then the mean spherical candle power will be roughly $\frac{300}{2} + \frac{2,000}{4} = 650$ British standard candles = 658 bougie-decimales; and the total quantity of light emitted from the lamp will be $658 \times 12.566 = 8,267$ lumens.

The peculiarity in the distribution of light in an arc lamp, just referred to, is due

to the fact that the upper or positive carbon is the seat of the crater. In the alternating-current arc, since the carbons are

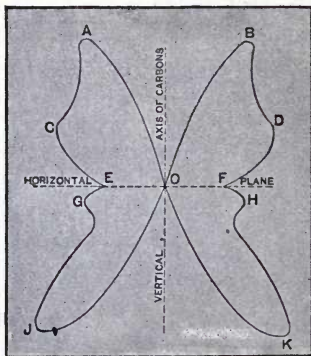

FIG. 103.—DISTRIBUTION OF LIGHT FROM AN ALTERNATING-CURRENT ARC.

alternately positive and negative, the distribution of light is markedly different, there being two maxima of intensity, one above and one below the horizontal plane.

This is shown in Fig. 103, where the luminous intensity is seen to reach a maximum about 50° both above and below the horizontal plane.

The *candle-power* or *intensity of light*, emitted by an arc lamp, owing to the unequal distribution of the light, is difficult to determine. A certain determination, taken in any particular direction, would give a candle-power which would depend not only on the intrinsic brightness of the arc, but also on the angle at which it was observed. The mean spherical candle-power is the best standard of reference to employ but requires considerable labor to obtain.

Arc lamps are commonly rated at 600, 1,200 and 2,000 candle-power. The ordinary lamps required for street lighting are

generally rated at from 1,200 to 2,000 candle-power. As a matter of fact, however, these figures are the maximum intensities which it is possible to obtain from the lamps at their angles of maximum intensity, with the best carbons, and in good condition of operation, so that a 2,000 candle-power arc lamp gives, probably, only about 600 mean spherical candle-power, or about 7,600 lumens. The 1,200 c. p. arc takes about $6 \frac{1}{2}$ amperes, and the 2,000 c. p. arc, about $9 \frac{1}{2}$ amperes.

The difficulty of determining the mean spherical candle-power of arc lamps has led many to abandon the use of candle-power as a standard of comparison, or means of rating, and to rate arc lamps by their electric activity. Thus a 10-ampere, 45-volt lamp, or 450-watt lamp, is, generally, assumed to give, under most favorable con-

ditions, 2,000 candle-power in its direction of maximum intensity. It is erroneous, however, to speak of a 450-watt lamp, as is frequently done, without specifying the voltage, since the light given by a 450-watt arc, when it consumes 12 amperes at 37.5 volts, is different from the light given by a 450-watt arc consuming 6 amperes at 75 volts.

The number of mean spherical candles obtained from an arc lamp per watt, is about $1\frac{1}{3}$ candles per watt, representing about 17 lumens per watt, assuming the absence of a globe, and a 450-watt, 45-volt arc.

The brightness of the crater is about 16,000 candles per square centimetre of surface, or, roughly, 100,000 candles per square inch.

The use of a globe over an arc lamp serves to distribute the light in a more

nearly uniform manner than would otherwise be possible, but the total quantity of light suffers marked diminution. Thus, if an arc lamp supplies 7,500 lumens without a globe, the superposition of a globe reduces the total quantity of light emitted to, perhaps, 3,750 lumens, or to a mean spherical candle-power of about 300 British candles.

In order to avoid the loss of light consequent upon its absorption by a globe, various forms of reflectors have been devised which will enable a more nearly uniform distribution of the light to be effected without the use of a globe. All such reflectors, however, add to the cost of the arc lamp in an appreciable degree. In the lighting of such areas as factories, where the main requirement is a fairly uniform distribution of the light, without

the consideration of artistic effect, the lamp shown in Fig. 104 may be employed.

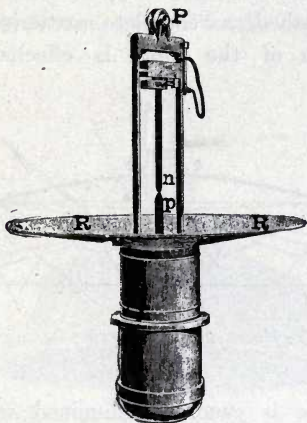

FIG. 104.—ARC LAMP FOR DIFFUSED LIGHTING.

Here the positive carbon p , is made the lower carbon and a simple reflector R , serves to throw the light of the lamp up-

wards or in the same direction as the light issuing from the positive crater. The walls and ceiling of the factory being whitewashed, a complete scattering and diffusion of the light is effected and

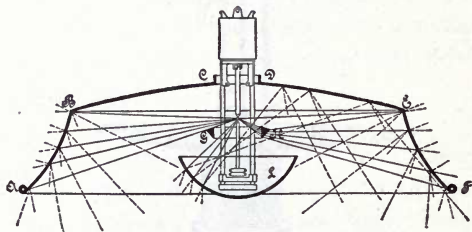

FIG. 105.—DIAGRAM OF CONTINUOUS-CURRENT ARC DIFFUSER.

the floor is generally illumined without pronounced shadows. This method was first employed in 1880 in lighting the gallery at the Paris Exhibition.

Fig. 105, represents another method of

diffusing the light from an arc lamp without the use of a globe. Here a large reflector *A B C D E F*, about 3 1/2 or 4 feet in diameter, is secured to the lamp frame

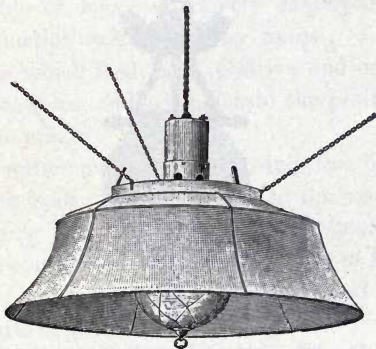

FIG. 106.—VIEW OF ARC DIFFUSER OF FIG. 105.

and painted white on its inner surface. An opalescent glass bowl *L*, is supported beneath the lamp and serves to diffuse the light which falls upon its surface. Fur-

ther diffusion is sometimes secured by the aid of a glass annular prism *G H*, which intercepts the most powerful beams of light and directs them into the diffuser.



FIG. 107.—FORM OF LIGHT-DIFFUSING GLOBE.

By these means the space beneath the diffuser receives a fairly uniform and powerful illumination. Fig. 106 gives a perspective view of the same device suspended

in position over the arc lamp. Special forms of diffuser are employed with alternating-current arc lamps.

Both the preceding methods are only capable of being effectively employed in conjunction with *focusing lamps*; *i. e.*, lamps which feed both positive and negative carbons, and so maintain the position of the arc.

Another method of diffusing the light which is also only applicable to the case of focusing lamps, but which is objectionable on account of its expense, is shown in Fig. 107. Here the diffusion is obtained by the use of prismatic rings of glass.

CHAPTER X.

PROJECTOR ARC LAMPS.

ALLUSION has already been made to the fact that in the continuous-current arc, the rate of consumption of the carbons is unequal, the positive carbon being consumed about twice as rapidly as the negative. All the mechanisms hitherto illustrated and described, feed but one of the carbons, generally the positive. Consequently, while the distance between the carbons remains constant, the position of the arc necessarily changes. For ordinary purposes this change in the position of the arc is not objectionable, but where the lamp is used in connection with some form

of reflector, or lens, a necessity exists for maintaining the source of light at the focus of the reflector or lens, and, consequently, a need for a *focusing lamp* arises.

In all focusing lamps both carbons are fed, the positive carbon being fed twice as rapidly as the negative. Various forms of mechanism have been devised for focusing lamps. A modern form of one of these mechanisms is shown in Fig. 108. Here the carbons are supported in holders, rigidly connected together through the medium of a common screw rod $S S S$. The lower or negative carbon N , is, however, supported in such a manner as to have a certain range of consumption under the control of the lever $L L$ pivoted at V . When no current passes through the lamp, the spring G , causes the lever $L L$, to raise the negative carbon N , until it is brought

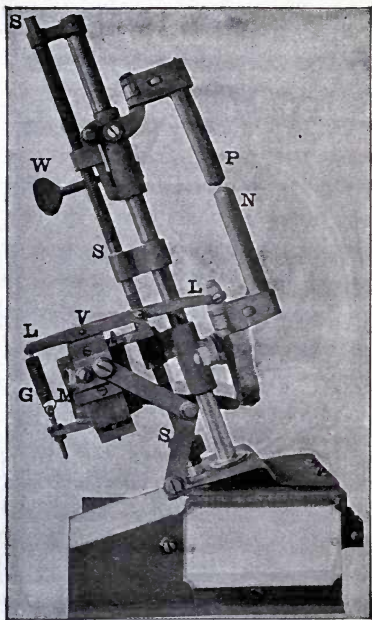

FIG. 108.—AUTOMATIC FOCUSING LAMP.

into contact with the positive carbon *P*. When, however, the current passes through the lamp, the magnet *M*, is actuated, its armature *A*, lowers the lever *LL*, and establishes the arc. A shunt magnet is placed in the base of the apparatus, and when the pressure becomes sufficiently great to allow it to attract its armature, a detent is withdrawn, permitting the screw shaft *SS*, to be driven in such a direction as to bring the two carbons together at the proper respective rates: The screw *W*, is intended for giving a slight rocking movement by hand in either direction to the positive carbon, so as to expose the proper portion of its surface to the action of the arc.

Practically all projector lamp mechanisms employed, operate on essentially the principle of the lamp above described.

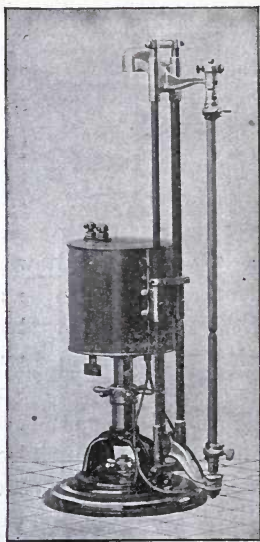

FIG. 109.—VERTICAL AUTOMATIC FOCUSING LAMP.

The driving mechanism, usually of clock work, brings the carbons together when

the arc becomes unduly long, and a series magnet separates the carbons on the first passage of the current. Fig. 109 shows a form of vertical carbon automatic focusing reflector. Here the working parts are concealed in a cylindrical case.

Focusing lamps are employed for a variety of purposes; namely,

Search lights and signaling.

Lighthouse illumination.

Stereopticon illumination.

Theatre illumination.

Scenic effects.

Photo-engraving.

Electric headlights.

Advertising.

A *search lamp* is simply a focusing lamp mounted in a cylindrical box and provided with a reflector and means for sending the beam, so obtained, in any desired direc-

tion. A reflector has to be employed in order to obtain a parallel beam. If an arc lamp gives 1,000 spherical bougies, and its light be considered as a mere point, the illumination produced by this amount of light, uniformly radiating in all directions, will be, at a distance of 100 meters,

$\frac{1,000}{100 \times 100} = 0.1$ lux. If now, by means of

a search-light reflector, sixty per cent. of this light be thrown in an approximately

parallel beam, then $12,566 \times \frac{60}{100}$ lumens

would be thrown into a parallel beam which would be lost by absorption only after traversing long distances of atmosphere.

Consequently, at a distance of 100 or 1,000 metres, the quantity of light would be 7,540 lumens. Practically no reflector can be made which will not itself absorb some light or which will render the

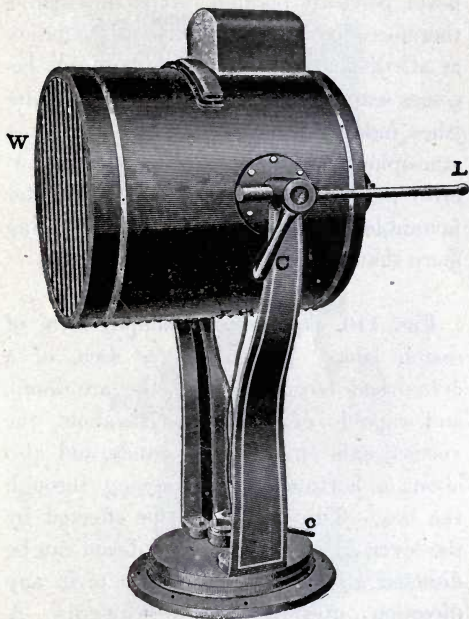

FIG. 110.—SIMPLE FORM OF SEARCH LAMP.

beam perfectly parallel. It is impossible, therefore, to obtain a uniform illumination at all distances. The light invariably becomes scattered and the illumination diminishes independently of absorption by the atmosphere, but the distance to which powerful lights can be visibly thrown, under favorable conditions, is very great, being more than 100 miles.

Fig. 110, represents a simple form of search lamp. It consists, as seen, of a cylindrical box containing the arc lamp, and capable of being moved about the vertical axis on which it stands, and also about a horizontal axis, passing through the box. This motion can be effected by the lever *L*. In this way the beam can be directed all around the horizon, or in any direction upwards or downwards. A clamp *C*, prevents motion about the hori-

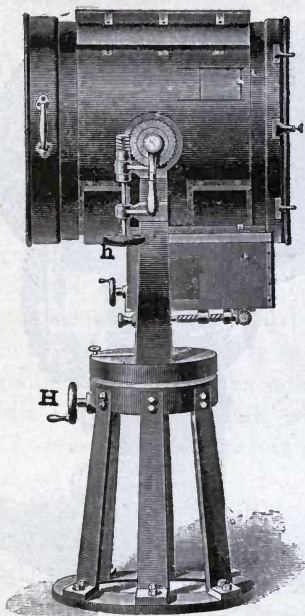

FIG. 111.—SEARCH LAMP WITH SLOW MOTION SCREW.

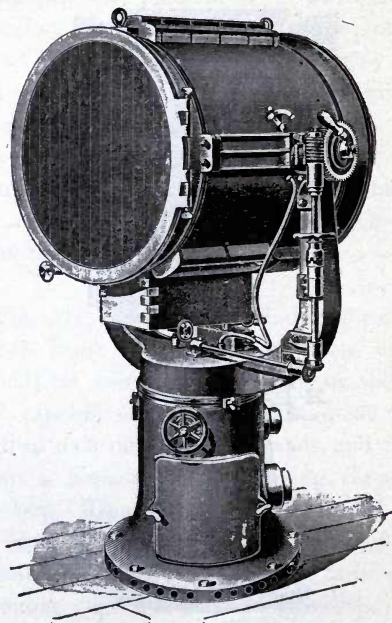

FIG. 112.—THIRTY-INCH PROJECTOR.

zontal axis when so desired, and another clamp *c*, prevents motion about the vertical axis. The window *W*, is provided with slats of thin glass in order to protect the arc from wind and weather.

When a projector exceeds a certain size, it is sometimes difficult to obtain the requisite accuracy of adjustment of the beam by hand, and slow motions, in both altitude and azimuth, are obtained by means of screws. Thus, in Fig. 111, the handle *H*, permits of a slow motion around the horizontal axis, or in azimuth, while the handle *h*, secures a slow motion in altitude.

Fig. 112, represents a still larger and more powerful projector of 30" diameter, where the slow motions in azimuth and altitude are arranged either for control at the side of the projector, or by gear, from

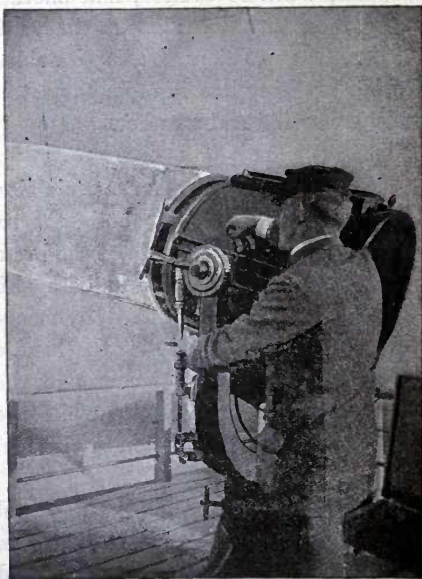

FIG. 113.—THIRTY-INCH PROJECTOR ON MOUNT WASHINGTON.



FIG. 114.—ILLUMINATION OF THE LIZZIE BOURNE
MONUMENT.

a distance. Fig. 113, shows this projector in operation. Some idea of the power of the projector shown in Figs. 112 and 113, in concentrating light at a distance, may be gathered from an inspection of Fig. 114, which shows the illumination produced at a distance of 1,200 feet, upon a monument, at night time.

Fig. 115 shows a form of *search-light projector* for use on vessels at sea, with gear control for projecting the beam from the pilot house. Fig. 116, represents the handles and part of the mechanism in the gear control for azimuth and altitude, while Fig. 117, represents the action of the mechanism. Another form of *pilot-house controlling gear* is shown in Fig. 118. In order to be able to utilize, for the operation of a search-light, the regular pressure of 110 or 80 volts, which may be employed

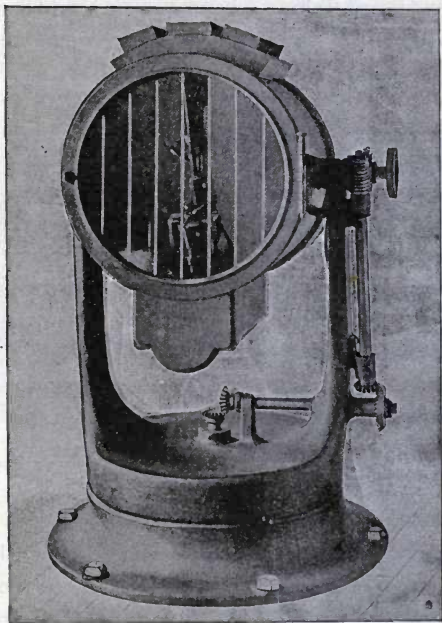

FIG. 115.—MARINE SEARCH-LIGHT PROJECTOR, WITH GEAR CONTROL.

on board ship, a *rheostat*, or regulable resistance, is inserted in the circuit of the arc lamp. The rheostat is arranged in

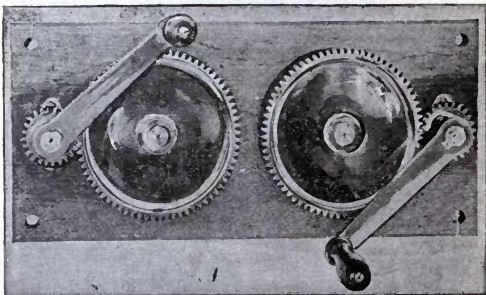

FIG. 116.—HANDLES FOR CONTROLLING BEAM OF PROJECTOR, LOCATED IN PILOT HOUSE.

such a manner that the turning of a handle enables resistance to be inserted in, or removed from, the circuit. Such a form of rheostat is shown in Fig. 119.



FIG. 117.—PILOT HOUSE OF YACHT "VARUNA" WITH SEARCH-LIGHT.

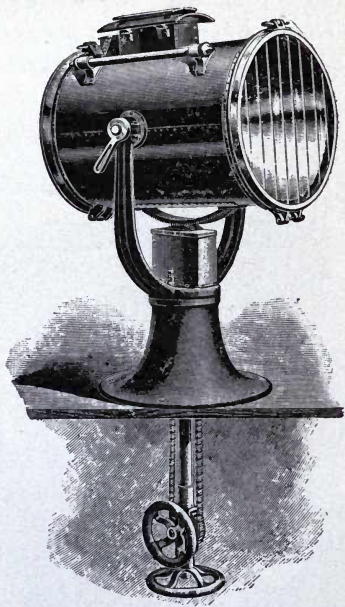

FIG. 118.—PILOT HOUSE CONTROLLING GEAR.

Perhaps the largest search-light projector ever constructed, was that exhibited at the Chicago Columbian Exhibition in

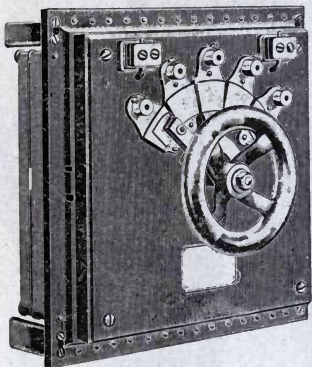

FIG. 119.—PROJECTOR RHEOSTAT.

1893. This projector is represented in Fig. 120. Its total weight is 6,000 pounds, and its reflector is five feet in diameter. It is operated by a current of

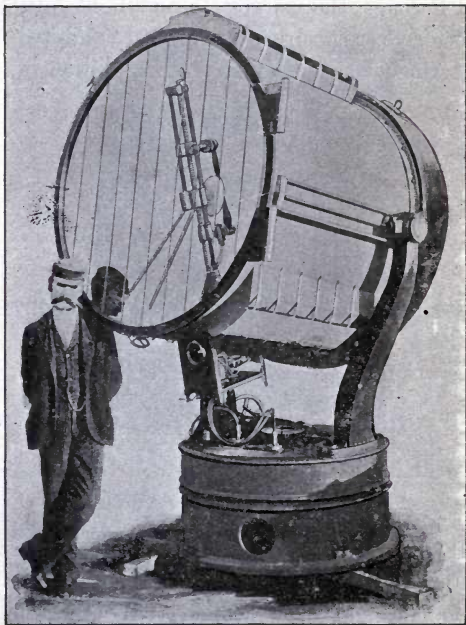

FIG. 120.—SIXTY-INCH PROJECTOR.

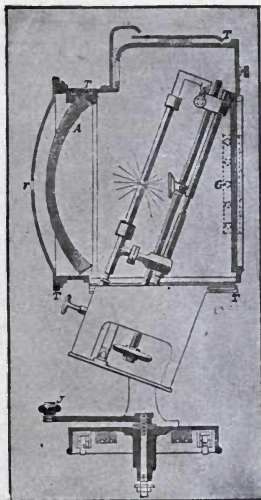

FIG. 121.—MANGIN'S PROJECTOR.

200 amperes, and, therefore, takes an activity of about 10 KW. or $13 \frac{1}{3}$ HP. Both carbons are cored; the upper carbon being $1 \frac{1}{2}$ " in diameter, and the lower car-

bon 1 1/4" in diameter. The dioptric reflector is a glass mirror of special form, called a *Mangin reflector*. It consists of a spherical mirror, whose inner and outer surfaces are of different radii. The outer surface is silvered, so that the rays coming from the lamp pass outward through the substance of the glass before being projected outward as parallel rays. Some idea of this form of projector can be obtained from an inspection of Fig. 121. It will be seen from this figure, and from Fig. 120, that the light is not allowed to pass directly from the arc into the beam, but is thrown from the arc, back to the Mangin reflector, partly with the aid of a small mirror placed in front of the arc, and then from the Mangin reflector outward.

The voltaic arc has long been employed for illumination from lighthouses. In

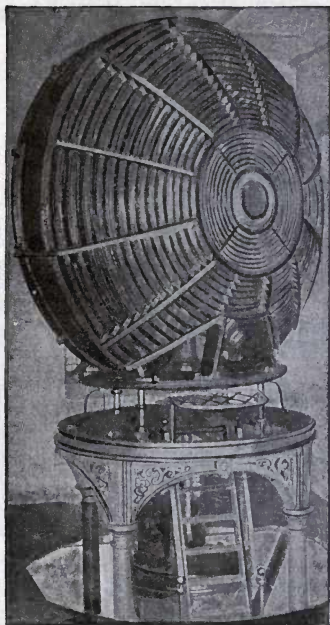

FIG. 122.—FIRE ISLAND LIGHTHOUSE LENS.

such cases the light is collected by a large lens and transmitted in a parallel beam.

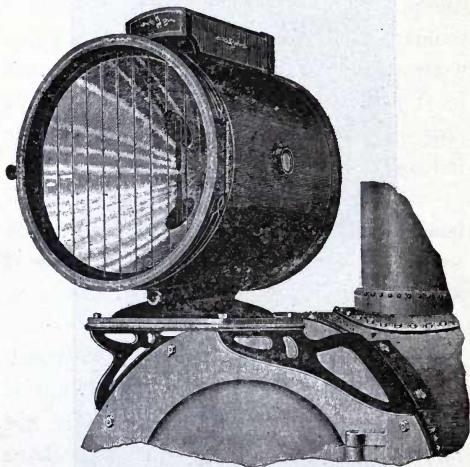

FIG. 123.—LOCOMOTIVE ARC HEADLIGHT.

The problem of *lighthouse illumination* differs markedly from that of the marine.

search-light, since, in the latter case, the object is to illumine a distant object, while that of the lighthouse is to mark the position of a certain point to vessels approaching in any direction.

Lighthouse illumination is of two distinct types; namely, the *fixed light* and the *flashing light*. In the illumination of the coasts or islands of a continent, it does not suffice to simply mark the position of the coast by a light. Means must be devised whereby one light can be readily distinguished from another. For this purpose various devices have been employed, such as colored lights, but the device most frequently employed is that of the *flashing light*. Flashing lights, as the name indicates, are lights visible to a distant ship during periodic intervals of time only, which vary with different lighthouses, so

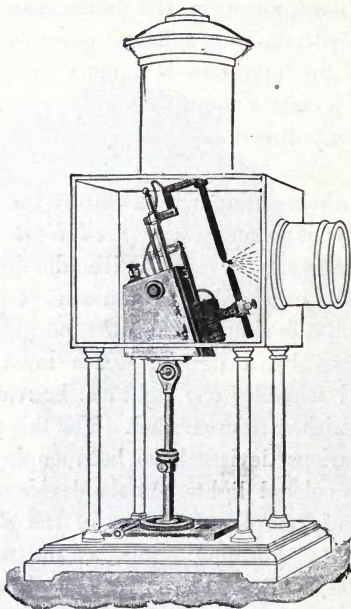

FIG. 124.—LANTERN PROJECTION ARC LAMP.

that it becomes possible for the ship to readily distinguish between a number of lights along a coast, comparatively near

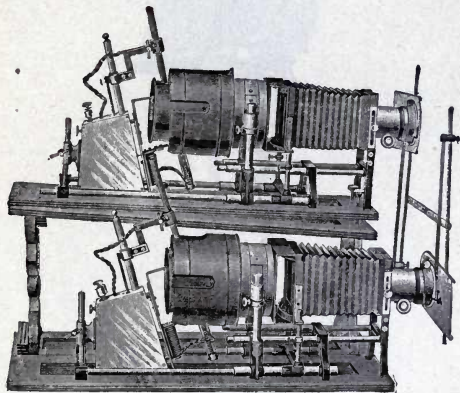

FIG. 125.—ELECTRIC STEREOPTICON.

together. Fig. 122, shows a form of *lighthouse lens* employed in the lighthouse on Fire Island, N. Y. This lens is nine feet



FIG. 126.—OPEN REFLECTOR STAGE LAMP.



FIG. 127.—STAGE LAMP.

in diameter and weighs half a ton. A focusing arc lamp is placed with its arc at the focus of the lens. The light after passing through the circular prisms emerges in a sensibly parallel beam. It is arranged to revolve once every five seconds, so that the light is of the flashing type. The arc used with this apparatus is about $\frac{1}{6}$ inch long, and the carbons are about one inch in diameter. The pressure is about 48 volts and the current about 100 amperes.

Arc-lamp projectors have been employed as *electric headlights* on locomotive engines. Fig. 123, shows a form of such attached immediately in front of the smoke stack.

A focusing arc lamp is employed to a great extent for the purposes of *lantern*

projection. A suitable form of focusing lamp is placed before the focusing lenses

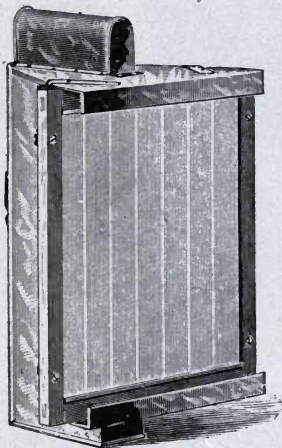

FIG. 128.—OLIVETTE BOX.

of the lantern, as shown in Fig. 124. A pair of such lamps, arranged for dissolving views, is shown in Fig. 125.

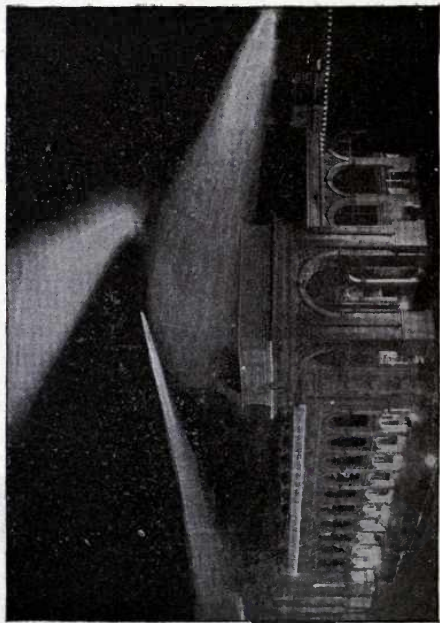

FIG. 129.—ILLUMINATION, WORLD'S COLUMBIAN EXHIBITION.

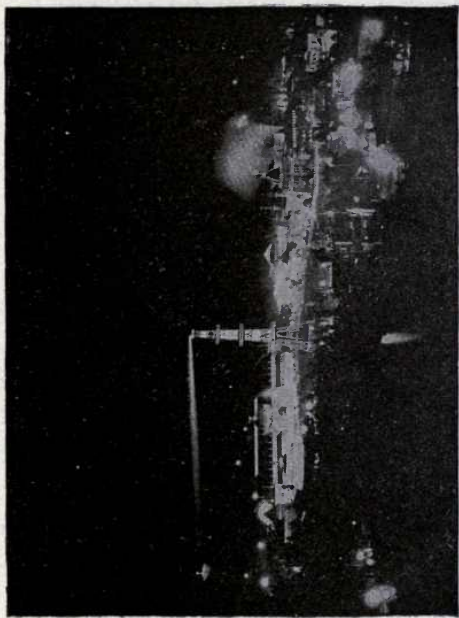

FIG. 130.—SEARCH-LIGHT EFFECTS, MID-WINTER FAIR, SAN FRANCISCO.

An electric arc lamp is frequently used in theatrical representations, and portable lamps are made to reflect the light in any required direction. Two forms of such lamps are shown in Figs. 126 and 127. The mechanism calls for no special consideration. Fig. 128, is an *olivette box*; namely, a box employed in front of the lamp for obtaining a uniform field of color over a large surface, such as a stage scene. A ground glass face ensures a thorough dispersion of the light and in front of this is placed a color frame to produce the requisite tint.

The search-light is frequently employed in order to produce striking scenic effects. Such effects were finely produced at the World's Columbian Exhibition, where the powerful search-light striking on the white "staff" covering the buildings

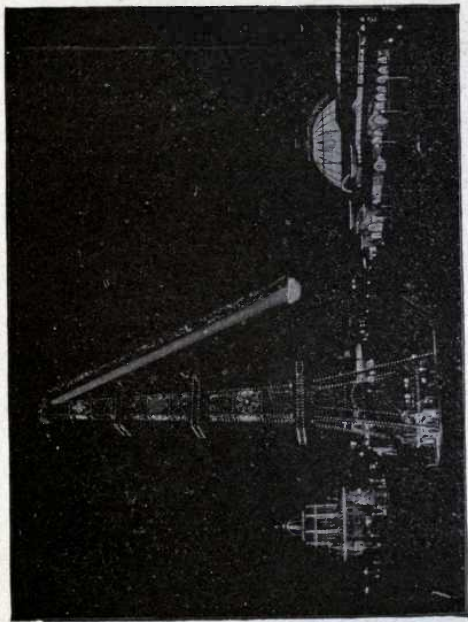

FIG. 131.—SEARCH-LIGHT EFFECTS, MID-WINTER FAIR, SAN FRANCISCO.

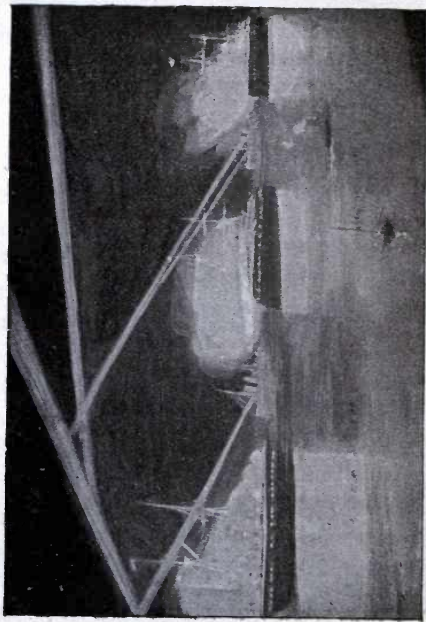

FIG. 133.—NAVAL REVIEW IN NEW YORK HARBOR.

illuminated them to great advantage. Fig. 129 represents the effect produced by the



FIG. 133.—PHOTO-ENGRAVING ARC LAMP.

arc lamps situated on the roof of the Manufacturers' Building at the World's

Fair. Figs. 130 and 131 show search-light effects produced at the San Francisco Mid-Winter Fair of 1895.

Fig. 132 shows the effect produced by search-lights in a naval review in New York harbor.

The preponderance of blue rays in the arc lamp, as well as its great candle-power, render it particularly useful for photographic purposes, thus making the operator independent of sunlight. Such lamps are frequently employed in *photo-engraving*. A form of lamp suitable for this purpose is shown in Fig. 133.

CHAPTER XI.

ARC LIGHT CARBONS.

FOR his early exhibitions of the voltaic arc, Davy employed rods or electrodes of willow charcoal. These gave an admirable light but possessed the disadvantage of too rapid consumption.

The first practical improvement in arc-light carbons was made by Foucault, who made use of the very hard carbon deposited on the inside of the retorts employed in the manufacture of illuminating gas, by the destructive distillation of coal. These deposits were cut and fashioned into the required shape by means of a saw.

They were a marked improvement, so far as duration was concerned, but possessed the disadvantage of not only being quite expensive, owing to the difficulty of working this extremely hard carbon, but especially from the fact that the carbon contained impurities and varied markedly in its hardness, thus giving rise to irregularities or flickerings of the light. Besides this, while such a source of carbon electrodes might have answered at the time of Foucault, yet, at the present day, when the daily consumption of carbon rods amounts to many hundreds of miles, this source of supply would be entirely inadequate, even were it satisfactory in other respects.

We have already referred to the discovery of the Grove voltaic cell, and its modification by Bunsen, as marking an era

in the history of electric lighting, not only on account of the more reliable source of electricity which his battery afforded, but also from the fact that the method he employed in the production of artificial carbons for the negative plates of his cells, disclosed a means whereby carbon rods could be manufactured for arc lights.

Inventors were not slow to avail themselves of the means thus pointed out, and many processes were devised for the production of artificial carbons. The method employed by Bunsen consisted substantially in making mixtures of finely divided carbonaceous materials with tar and glue, and subjecting the same to a *carbonizing* or baking process, while out of contact with air. Unfortunately, during this process the material employed to bind the mixture of carbonaceous materials together,

resulted in the production of a semi-porous mass of carbon. Bunsen increased the density of his carbons by soaking them in sugar solution and re-carbonizing. By repeating this process he obtained very dense, fairly uniform carbons.

Although many improvements have been made in the practical production of arc light carbons, yet the processes are essentially developments of this early method of Bunsen, and consist, substantially, like the Bunsen process, of thoroughly incorporating some carbonizable liquids with various mixtures of pure carbon, and passing the same, under hydraulic pressure through suitably shaped dies. The carbon rods so obtained, are then carefully dried and subjected to various processes of carbonization, generally as in the Bunsen process, and are subsequently

subjected to rebakings after immersion in syrup or other carbonaceous liquid. Before, however, proceeding to the fuller description of the modern process employed in the manufacture of arc light carbons, a brief history of early carbon manufacture may not prove uninteresting.

As early as 1846, Staite and Edwards, who were among the pioneer inventors in arc-lamp mechanism, took out a patent for the manufacture of arc light carbons, on essentially the same lines as employed by Bunsen in 1849. A Frenchman by the name of Le Molt, patented a substantially similar process for the manufacture of carbon electrodes, observing, however, great care in the prior purification of the carbons. In 1857, Lacassagne and Thiers, the inventors of the shunt-circuit arc lamp,

endeavored to employ gas-retort carbons, purified in various processes, by the removal of its silicon and other materials. Probably the most successful endeavor, in this direction, however, was that made by Jacquelain, who prepared pure artificial gas-retort carbons by distillation of purified tar.

In 1876, Carré took out a patent for the manufacture of carbons, which, however, did not differ markedly from the preceding. Carré employed a mixture of powdered coke, lamp-black, and a specially prepared syrup formed of cane sugar and gum. As before, the materials, mixed into paste and passed through a die under hydraulic pressure, were dried and subsequently carbonized. The pencils were then re-treated in sugar solution and then re-carbonized.

The prime essential of a good electric light carbon is purity of material. The effect of impurity on any carbon must necessarily be to lower the temperature of the arc, and thus very materially diminish the amount of light emitted; for, as we have seen, the temperature of the positive crater is that of the volatilization of the materials, and the presence of substances whose points of volatilization are much lower than that of carbon, must result in a considerable diminution of temperature and, consequently, in a decrease of the intensity of the light. The purity of the carbon being assured, the next most important point is the homogeneity of the material. Carbons vary very considerably in their compactness or hardness. Consequently, if the carbons are made from a mixture of various carbonaceous powders, unless all of these ingredients possess

nearly the same hardness, irregularities both in the consumption and temperature will cause unsteadiness of the light. Thoroughness of mixture, and uniformity as near as possible in the hardness of the different carbon ingredients must, therefore, be ensured.

The processes employed at the present day for the manufacture on a commercial scale, of arc light carbons, may be divided into two general processes; namely, *moulding* and *squirting*.

In the moulding process, as the name indicates, the carbonaceous material, in the form of a paste, is moulded in suitable forms by hydraulic pressure. Different carbonaceous materials are employed by the different makers, but refined petroleum coke, ordinary gas coke, and lamp-

black are among the commonest. A high degree of uniformity and purity is necessary, and whatever means are employed for mixing, it is essential that this mixing shall be thorough. The solid materials are thoroughly ground and mixed into a stiff paste. The moulded material is then thoroughly dried, the drying being gradually accomplished by passing the material through ovens at successively increasing temperatures. Finally, the carbons are *fired*, or subjected to a *carbonizing process*, while wholly out of contact with air, by prolonged exposure to intense heat. If properly prepared, the carbons should have, when struck, a metallic ring, indicative of great hardness. In some processes, as we have seen, the carbons are subjected to a rebaking, after dipping in saccharine solutions, for the purpose of increasing their *density*. In order to ensure the ready and

thorough penetration of the liquid into the interior of the carbons, they are sometimes treated with the saccharine liquid while in a vacuum.

We have already referred to the unsteadiness of the arc light, due to the *travelling of the arc*, and have alluded to the fact that this travelling may be decreased by the use of cored carbons. In *cored carbons*, as the name indicates, the core or central part of the carbon is formed of a different material from the main body of the carbon. These carbons are prepared by squirting the material through a proper die, so as to leave a cylindrical cavity at the centre of the carbons. This cavity is subsequently filled with a softer variety of carbon.

Electric light carbons are either *bare* or *coppered*. Coppered carbons are coated

with a thin adherent conducting layer of metallic copper, deposited electrolytically.



FIG. 134.—SOLID COPPERED CARBON ROD.

The carbon electrodes are immersed in a bath of copper sulphate, while connected with the negative terminals of an electric

source, and placed opposite plates of copper connected with the positive ter-



FIG. 135.—CORED CARBON ROD.

minal. The effect of the copper coating is to increase the life of the carbons, and to

ensure a more nearly uniform consumption with a reduced expenditure of energy in the resistance of the carbon rods. Moreover, the thin coating of copper largely

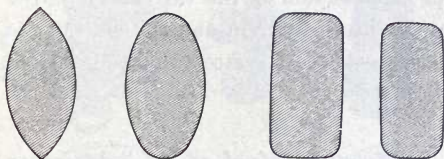

FIG. 136.—CROSS SECTIONS OF CARBONS.

prevents the disintegration of the carbons, except within the arc.

Carbons are of various shapes, although the cylindrical form is generally employed. They are of various diameters, from $1/4''$, up to an inch or more. The lengths are generally either one foot, or seven inches. A form of coppered cylindrical *solid carbon*, *i. e.*, a *coreless carbon* is shown in Fig. 134.

A longitudinal section through the axis of a cored carbon is shown in Fig. 135. Fig. 136, shows various cross-sections employed for special or *long-lived carbons*. The cross-section of the carbons employed varies with the current and voltage, but the commonest size for street lighting is $1/2''$ in diameter.

The *length of life* of an arc light carbon depends upon the current strength and upon the diameter of the carbon, as well as on its hardness and character. The usual duration of a pair of half inch carbons is about nine hours, and a pair of $7/16''$ about seven hours.

Various forms of *carbon holders* are employed both to attach the upper carbon to the lamp rod, as well as to hold the lower carbon in position. Frequently the lower

carbon is provided with an *ash pan*, a device for preventing it from dropping through the holder, and so possibly caus-

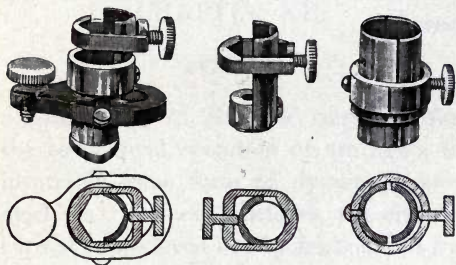

FIG. 137.—CARBON HOLDERS.

ing damage or fire. A few forms of carbon holders are shown in Fig. 137.

When a lamp maintains its arc at too short a distance, a disagreeable hissing noise is apt to be produced. If burnt at too long an arc, a flaming of the arc, often

accompanied by noise, is produced. The voltages required to bring about the hissing and flaming of an arc will vary considerably with the character of the carbons.

CHAPTER XII.

DYNAMOS.

THE source of E. M. F. employed for the commercial operation of arc lights is invariably some form of dynamo-electric machine. In these machines, the electric current is produced not by friction, but by the rotary movement, through *magnetic flux*, or magnetism, supplied by the field coils, or coils of wire secured to the armature. When a coil of wire passes one of the poles in the field frame, the E. M. F. makes one reversal; *i. e.*, an impulse of E. M. F. in one direction is produced, and the next pole it passes will develop in the wire an impulse of E. M. F. in the oppo-

site direction, so that, if, as is often the case, the field frame has two poles, or the machine is a *bipolar machine*, the coil will receive two impulses of E. M. F. during one revolution, one impulse, being say positive, and the next impulse, negative. The coils are arranged in such a manner that the E. M. Fs. which are induced in them by their rotation past the poles are united, and if the machine is provided with a commutator, the alternate impulses of E. M. F. are so timed in reference to the passage of the commutator beneath the brushes resting upon it, that the current in the external circuit does not alternate but remains uniform in direction. Such a machine is called a *continuous-current machine*.

Sometimes, however, no attempt is made to commute the direction of E. M. F., the ends of the coils being directly con-

nected with the external circuit. In this case, the E. M. F. and current generated will be alternating, not only in the armature, but also in the external circuit. It is generally easy to determine from a casual inspection of a dynamo, whether it has been designed to furnish continuous or alternating currents. In the former case it will always be provided with a commutator. In the latter case no commutator will be seen, although alternating-current generators; *i. e.*, *alternators*, are sometimes *self-exciting*, or are provided with a commutator, the function of which is to commute a small portion of the alternating current supplied by the machine, which commuted current is used to energize its field coils.

Fig. 138, represents a particular form of bi-polar continuous-current arc-light gen-

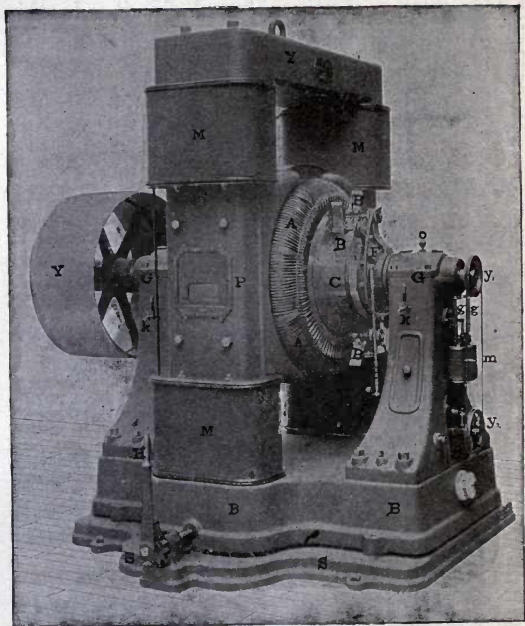

FIG. 138.—BIPOLAR CONTINUOUS-CURRENT GENERATOR.

erator, intended to produce a current of 9.6 amperes, at a maximum pressure of 6,250 volts, and, therefore, to deliver an output of $9.6 \times 6,250 = 60,000$ watts, or 60 KW approximately 80 HP when running at a speed of 500 revolutions per minute. Such a machine is intended to supply 125 arc lamps in series. The machine rests upon a cast iron base BB , which is capable of being advanced along the surface of the base frame SS , by means of a ratchet worked by the handle H , thus enabling the driving belt, not shown in the figure, but which rests over the driving pulley Y , to be tightened. The field frame $BMPMYM$, has four magnetizing coils M, M, M, M , and magnetizes two pole-pieces, one of which P , is seen in the figure. Between these two poles rests the armature AA , in two main journal bearings G, G . The commutator C , con-

sists of a number of insulated conducting segments, each symmetrically connected to some point of the armature winding. Commuted currents are carried off from the commutator by the brushes B, B , of which there are two pairs, one pair for each terminal. The position of these brushes relatively to the commutator, is adjusted automatically, by imparting a rotary movement, when necessary, to the brush holder frame F , through the rod R , under the influences of the regulator m , which is placed in the main circuit of the machine. When the current exceeds a certain strength, the regulator magnet m , attracts its armature more powerfully against the opposing forces of a spring, moving the brushes in one direction over the commutator, and when the current unduly weakens, the brushes are moved in the opposite direction. The power for

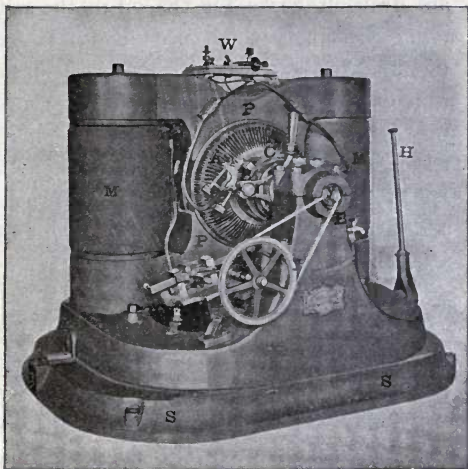

FIG. 139.—SERIES ARC DYNAMO.

moving the brush holder frame in obedience to the action of the regulator magnet, is obtained from the armature shaft, through the belt and the pulleys *y y*. *k k*,

are draw-off cocks for the oil in the self-oiling bearings, which are filled through the aperture *O*. When, during the rotation of the machine, the coils on the armature are moved forward through the magnetic flux produced by the field magnets, E. M. Fs. are generated in the former, and are carried to the arc light circuit after they have been commuted.

Fig. 139, represents another form of bipolar continuous-current arc-light generator. Here the pulley is not visible but the armature *A A*, revolves with its conductors and commutator *C*, in the magnetic flux produced between the poles *P, P*, under the excitation of the magnetizing coils *M, M*. Here the regulator *R*, actuated through the pulleys *y y*, adjusts the positions of the brushes *B*, of the commutator. The switch *W*, opens and closes a short cir-

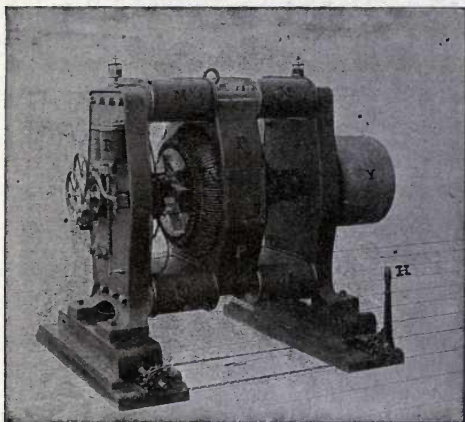

FIG. 140.—BIPOLAR GRAMME-RING ARC-LIGHT GENERATOR.

cuit around the field magnets. In order to tighten the belt, the handle *H*, is used.

Fig. 140, shows another form of bipolar Gramme-ring arc-light generator, intended

for the supply of eighty 2,000 candle-power arc lamps, and, therefore, capable of producing, at its terminals, a pressure of 4,000 volts at a speed of 875 revolutions per minute, and with a current of 9.6 amperes. This represents a maximum external activity of 38.4 KW or about 51.2 HP. Here the armature *A*, driven by the belt on the pulley *Y*, rotates between the poles *P, P*, which are produced by the magnetizing coils *M, M, M*. Two pairs of brushes, one of which only is seen in the figure, rest upon the commutator. A regulating magnet *R*, controls the position of these brushes so that the current strength in the circuit remains constant. Fig. 141, is a diagram representing the connections of this machine, and may be taken as typical of the connections of a series-connected continuous-current arc generator. By tracing the connections, it will be seen that

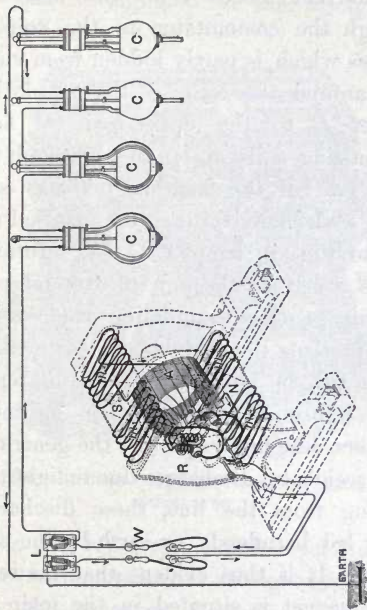

FIG. 141.—DIAGRAM OF CONNECTIONS IN GENERATOR SHOWN IN FIG. 140.

the current issues from the armature through the commutator to the pair of brushes which is partly hidden from view, then around the coils of the regulating magnet R , to the upper pair of field magnetizing coils $m_1 m_2$, then through the lower pair of the field magnetizing coils $m_3 m_4$, and finally through the external circuit to the arc lamps $C C C C$, returning to the armature through the second pair of brushes, thus completing the circuit.

W , represents the switchboard connections which will be alluded to later. L , represents lightning protectors, or lightning arresters, designed to protect the generator from accidental discharges due to lightning arriving from the line, these discharges being led harmlessly to earth by the wire shown. It is thus evident that the regulator magnet is situated in the main circuit, and through its action the strength of

the current supplied in the machine is maintained constant.

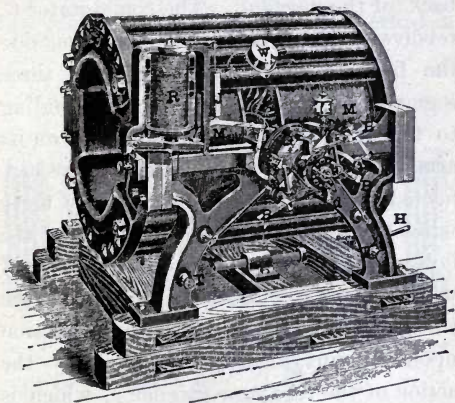

FIG. 142.—BIPOLAR CONTINUOUS-CURRENT ARC-LIGHT GENERATOR.

Fig. 142, represents another form of bipolar continuous-current arc-light generator. Here the armature *A*, part of which is just visible in the centre of the machine, is

rotated between the poles produced by the large magnet coils M, M , by a pulley at the back of the machine. The commutator C , revolves with this armature, but outside the bearing G , and contains only three segments on its commutator, corresponding to the three coils which are wound on its armature. These three segments are connected with the armature coils by three wires which pass through the centre of the hollow shaft. The brushes B, B, B , of which there are two pairs, rest upon the surface of this commutator, their position upon the surface being regulated by the action of the regulator magnet J , which is connected in the main circuit. T, T , are the main terminals of the machine. M , is a dash-pot filled with glycerine for preventing sudden movements of the regulator. W , is a field short-circuiting switch,

Fig. 143, represents in detail the various parts of the preceding generator. (1), is the armature, which is nearly spherical in

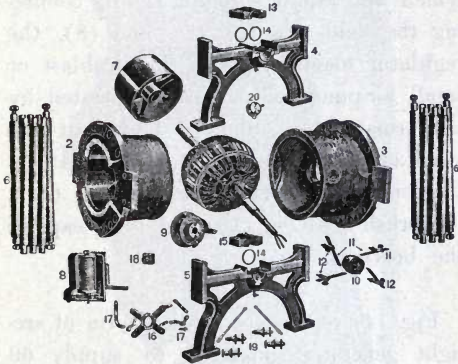

FIG. 143.—PARTS OF GENERATOR SHOWN IN FIG. 142.

shape, the coils being connected so as to form three windings, the ends of which appear at the end of the shaft. (2), is the left hand field coil and frame; (3), the

right hand field coil and frame; (4), is the pulley journal bearing; (5), the commutator journal bearing; (6), are the field rods which are bars of soft iron rigidly connecting the field magnet; (7), and (8), the regulator magnet; (9), is the air blast or small air-pump mechanically operated by the armature in order to blow out the spark at the commutator segments; (10), is the commutator; (11), the brushes; (12), the brush holders; (13) and (15), caps of the bearings.

Fig. 144 represents another form of arc-light generator intended to supply 60 lamps of 2,000 candle-power, and, therefore, capable of furnishing 3,000 volts at its terminals. The armature *A A*, is driven by a belt on the pulley *Y*, between the poles *P, P*, produced by the four magnetizing coils *M, M, M, M*. The three

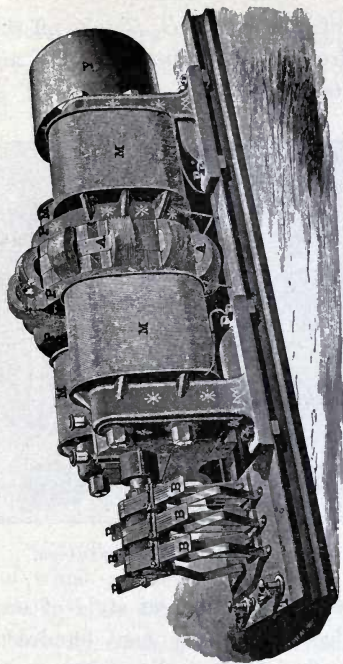

FIG. 144.—ARC-LIGHT GENERATOR.

pairs of brushes, *B, B, B*, take off the current from the commutator. *T, T*, are the main terminals.

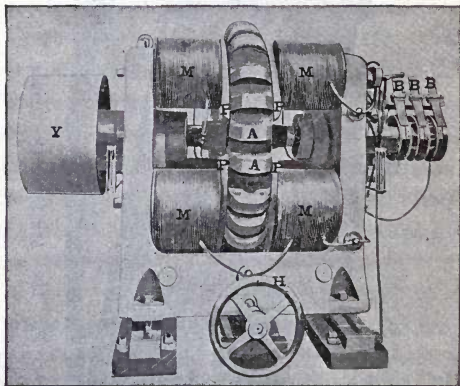

FIG. 145.—ARC-LIGHT GENERATOR.

A somewhat different style of machine intended to supply one hundred and twenty-five 2,000 candle-power arc lamps,

and, therefore, developing a maximum of about 6,250 volts at its terminals, is shown in Fig. 145. Here the armature $A A$, re-

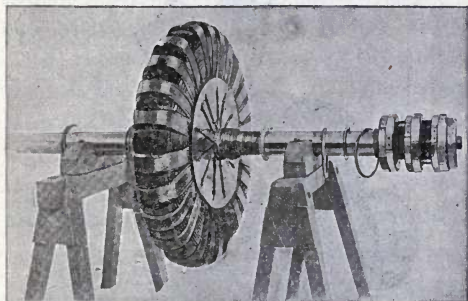

FIG. 146.—ARMATURE OF GENERATOR SHOWN IN FIG. 145.

volves between the four poles P, P , two only of which are seen. There are four magnetizing coils M, M , and three pairs of brushes B, B, B , as before. The general arrangement of the armature, its shaft

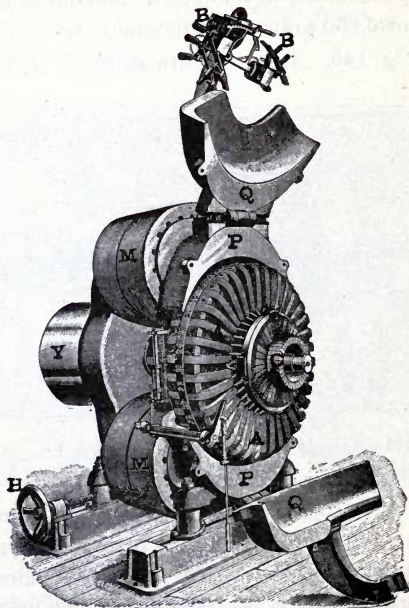

FIG. 147.—ARC-LIGHT GENERATOR.

and the commutator, can be best seen from an inspection of Fig. 146.

Fig. 147, shows another form of arc-light generator capable of supplying one hundred and twenty-five 2,000 candle-power lamps. *A, A*, is the armature driven by the pulley *Y*, between the poles *P, P*. The pole faces *Q, Q*, are unhinged, and thrown aside, ready to permit the armature to be inspected or withdrawn. *M, M*, are the magnetizing coils, and *B, B*, the brushes.

Fig. 148, shows a larger machine of this type with the pole faces in place. This machine is intended to supply two hundred 2,000 candle-power arc lamps in a single circuit, and, therefore, is capable of furnishing about 10,000 volts and 10 amperes at its terminals. Such a machine has a capacity of 100 KW, or about 134 HP, at 625 revolutions per minute.

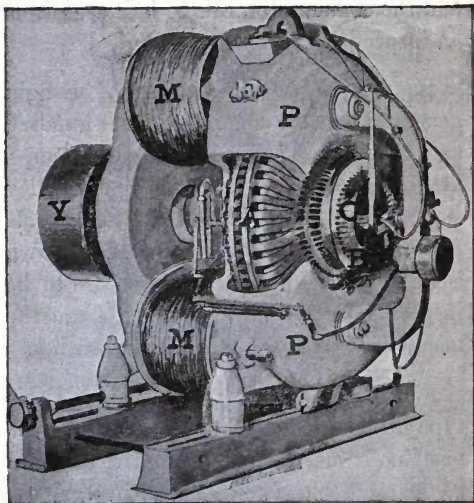

FIG. 148.—ARC-LIGHT GENERATOR.

The generators we have heretofore described in this chapter, have all been designed to furnish continuous currents.

It has already been mentioned that arc lamps can be satisfactorily operated by

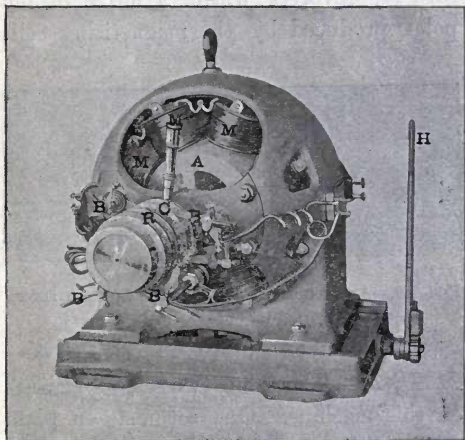

FIG. 149.—30 KILOWATT ALTERNATOR.

means of alternating currents. We will, therefore, describe a form of *alternating-current generator*, or *alternator*, employed

for this purpose. This is seen in Fig. 149. Its capacity is 30 KW. Here the armature *A*, revolves within a circle of ten poles produced by the magnetizing coils

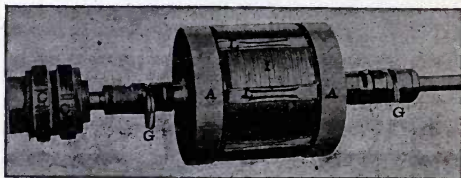

FIG. 150.—ARMATURE OF TYPE OF ALTERNATOR SHOWN IN FIG. 149.

M, M, M. There are two sets of brushes on this machine. One set rests on plain collector rings *R, R*, and carries off the alternating currents from the armature to the external circuit, while the others rest on a double commutator *C*, for the purpose of commuting a portion of these cur-

rents to be used in exciting the field magnets with a continuous current.

Fig. 150 shows the armature of such a machine in greater detail. A, A , is the armature frame, I, I , laminated iron discs or sheet stampings associated together on the shaft and forming the iron core. C, C , the double commutator. G, G , the oil rings for keeping the oil in the bearings in motion over the shaft.

Fig. 151, indicates the method by which the armature coils are set in position on such an armature. Here the iron core discs I, I , are seen rigidly attached to the shaft S, S, S . The coils L, L , are wound on suitable frames and then slipped into their position on the iron teeth I, I , by the aid of a handvise V , shown in position at the top of the armature.

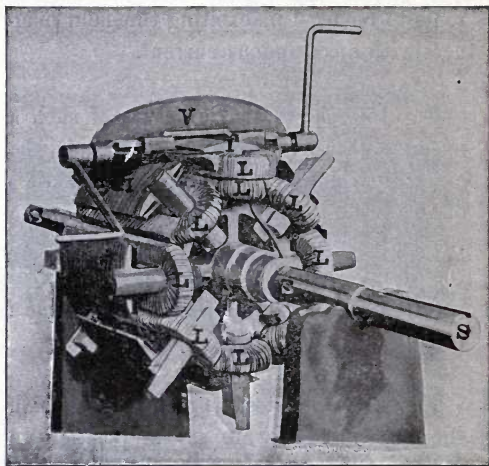

FIG. 151.—ARRANGEMENT OF ARMATURE COILS.

We have hitherto described belt-driven arc-light generators, that is, arc generators in which the power of the engine is communicated to the generator by means of a belt. In some cases, however, the belt

is omitted, and the generator shaft is coupled directly to the main shaft of the driving engine. Such a direct-coupled machine is represented in Fig. 152. Here the arc-light generator G , of 50 KW capacity, is coupled directly to the 90 HP compound engine through the coupling C . The common shaft of the engine and generator makes 460 revolutions per minute. Such a connection is economical of floor space and is finding favor in large central stations where large units of power are employed. It necessitates the use of comparatively high-speed engines and of comparatively low-speed generators.

The arc-light generators here described are either installed directly in the building to be lighted; or, as is more generally the case, in a central station. The latter arrangement possesses a marked ad-

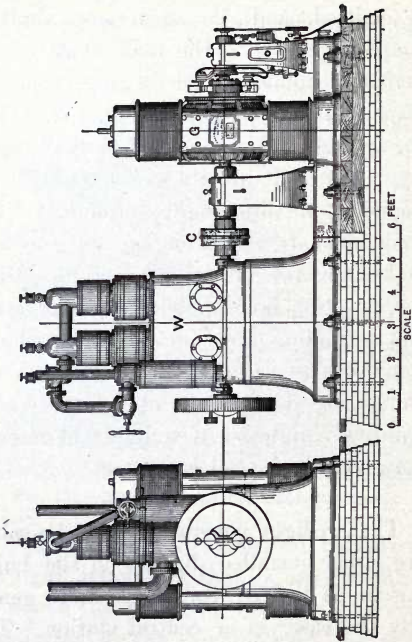

FIG. 152.—DIRECT COUPLED GENERATOR.

vantage over the former in economy of operation over a large district. In central station practice, where a number of dynamos are employed, the necessity frequently arises to transfer the current and load from one dynamo to another, or at times to connect two or more dynamos in series. This operation is performed through the agency of a *switchboard*. Such a switchboard will contain, besides devices for effecting the ready transfer of circuits, or for the coupling together of dynamos, various instruments for measuring the current on each circuit. Moreover, since arc light circuits extend over considerable areas, and danger would result from an accidental flash of lightning entering the station, lightning protectors are usually provided. Fig. 153, represents such a switchboard situated on the wall of a central station dynamo room.

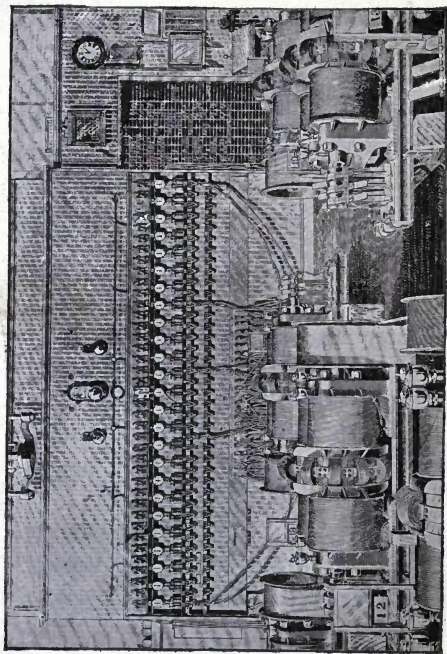

FIG. 153.—SWITCHBOARD FOR CENTRAL STATION.

Here carefully insulated conducting cords connect the various machines with

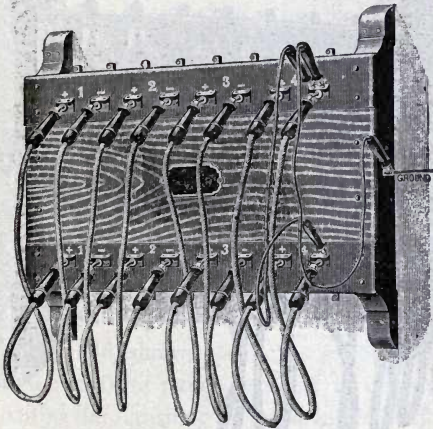

FIG. 154.—ARC SWITCHBOARD.

the different circuits, each circuit and each generator having their respective numbers. An ammeter is permanently placed in each

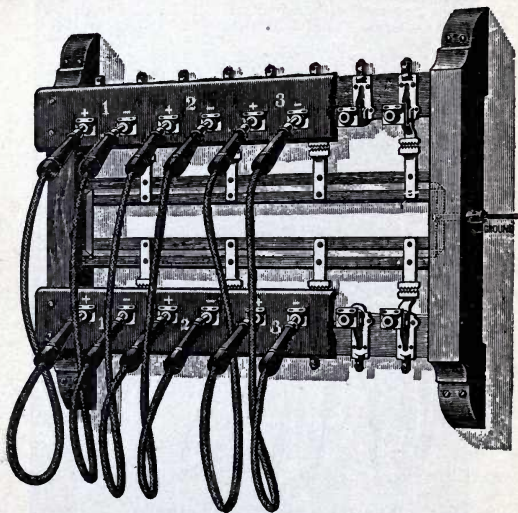

FIG. 155.—SWITCHBOARD WITH FACE REMOVED.

circuit to show the current strength passing in the same.

Fig. 154, shows another form of switch-board. Here the generators are brought to the lower row of terminals marked +1-, +2- etc., while the circuits are brought to the upper row, marked +1-, +2- etc. By suitably connecting the dynamos and their circuits, with pin plugs, the current delivered from the station can be controlled. The cut shows each dynamo at work upon its own circuit, although it is evident that any one dynamo could be applied to operate any other circuit.

Fig. 155 shows the same switchboard with the front panel removed in order to exhibit the lightning arresters in place with their lower jaws connected directly to the ground.

CHAPTER XIII.

ENCLOSED ARC-LAMPS.

WHEN a direct-current arc-lamp is operated in free air, as in the ordinary open arc-lamp, the principal consumption of carbon takes place at the positive electrode. Here the carbon is partly volatilized, and partly consumed by combination with oxygen in the surrounding air. With the exception of such portions as become disintegrated and drop from the arc, nearly all of the carbon eventually becomes consumed by combustion. If, however, the arc be placed in a closed chamber from which nearly all the air has been exhausted,—*i. e.*, in what is practically a

vacuum,—the arc can still be maintained between the carbons, but the consumption of carbon by combustion will have practically ceased. The volatilization of carbon will, of course, continue from the positive electrode, and a large portion of this volatilized carbon will be deposited upon the extremity of the negative electrode, while a smaller portion will be deposited as a thin layer upon the walls of the containing vessel. Under these conditions, the life of the carbons will be very greatly increased.

It is impracticable to operate arc-lamps *in vacuo*; but it is practicable to prevent oxygen from obtaining free access to the arc. This is accomplished by placing a small thin glass bulb, or inner globe, around the carbons, so that only a small free space is left

between the positive carbon and the edge of the inner globe. When the arc is first established within this globe, the oxygen of the air it contains is rapidly removed by combustion. The chamber, neglecting the vapor of carbon, and oxides of carbon, then contains nitrogen, an inert element. The contained gases are heated to a relatively high temperature by the arc within the globe, and the entrance of fresh oxygen, through the narrow annular aperture surrounding the positive carbon, is necessarily very slow. Under these conditions the consumption of carbon by combustion is greatly diminished, being mainly reduced to that by volatilization. Consequently, the consumption of positive carbon, instead of being roughly about an inch per hour, is reduced to about $1/14$ " per hour, while the consumption of the negative carbon, instead of being

about $1/2''$ per hour, is only about $1/40''$ per hour; or, about $1/3$ rd of the consumption of the positive carbon. These consumptions refer to a current strength of 5 amperes. A $1/2'' \times 12''$ positive carbon, at this rate, would last 168 hours, if it could be entirely consumed. In practice, the life of carbons, in ordinary enclosed arcs, is from 100 to 150 hours. The life-time depends in some degree upon the number of hours of consecutive operation, since at each intermission, and cooling of the lamp, some oxygen finds access to the inner globe.

Enclosed arc-lamps have now largely superseded open arc-lamps, mainly owing to the fact that the expense of recarboning is thereby reduced. The amount of light yielded by an enclosed arc-lamp is really less than the amount of light which would

be yielded by the same electric power in the open arc, by reason of the absorption of light within the walls of the inner globe. On the other hand, the light from the enclosed arc is much more uniformly distributed than the light of an open arc, since the inner globe diffuses the light. Enclosed arc-lamps are operated from both direct-current and alternating-current circuits, either in series or in parallel, the lamps being constructed and adjusted to meet these different conditions.

The interior mechanism of a Manhattan, direct-current, constant-potential enclosed arc-lamp is shown in Fig. 156. A resistance coil, wound on a porcelain grooved cylinder, is placed in series with the arc, to prevent overloading the lamp by a short circuit through the carbons,



FIG. 156.—MECHANISM OF A MANHATTAN DIRECT-CURRENT CONSTANT-POTENTIAL ENCLOSED ARC LAMP.

which are initially in contact. It also keeps the required pressure at the car-

bons when the normal current is flowing through the apparatus. An electromag-

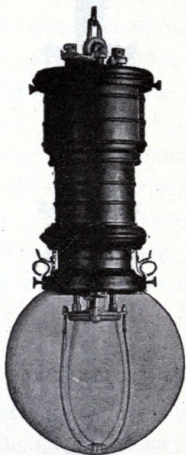

FIG. 157.—INDOOR LAMP WITH COVER AND GLOBE.

net, also in series with the arc, controls the feeding mechanism. The inner globe may be either of clear or opalescent

glass. A general view of the indoor lamp, with the glass cover and outer globe in

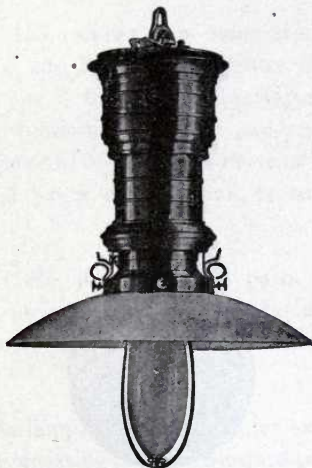

FIG. 158.—INDOOR LAMP WITH REFLECTOR.

place, is seen in Fig. 157. These lamps are constructed for 110-volt, direct-current circuits, and are intended to take either

4.5 amperes, or 3 amperes, with from 75 to 80 volts between the carbons. Both

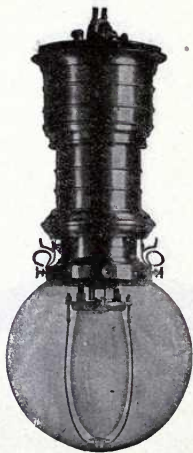

FIG. 159.—OUTDOOR LAMP.

electrodes are solid $1/2$ " carbons, the upper or positive, being 12 ", and the

lower or negative, 5" in length. The normal life of the carbons is 150 hours.

Fig. 158, shows the same lamp with reflector, and Fig. 159, illustrates the outdoor type. In the alternating-current, constant-potential, enclosed arc-lamp, the resistance coil of the direct-current lamp is replaced by a choking coil, or reactance coil.

Fig. 160, shows several parts of enclosed arc-lamp mechanism, including a resistance, a reactance coil, and a top plate.

These lamps are designed for operation from alternating-current, constant-potential mains, at from 100 to 120 volts pressure, with frequencies from 60 to 133 cycles per second, the arc voltage being automatically reduced to 70 volts with a

normal current of 6 amperes. At 105 volts terminal pressure, the power-factor is about 71.5 per cent. The carbons



FIG. 160.—DETAILS OF LAMP.

are $1\frac{1}{2}$ " in diameter, one being cored and the other solid, the upper carbon being 10" long and the lower 5". The normal life is from 80 to 100 hours. An outer globe not only protects the inner globe from the weather, but also aids in preventing the oxygen of the air from obtaining access to the arc. The outer globe is often omitted and replaced by a reflector. This lamp affords a very

efficient way of lighting interiors of stores and windows.

Particular attention has to be paid to the quality of the carbons employed with enclosed arc-lamps; otherwise, the inner globes will become rapidly blackened. Even with the best carbons, the inner globes require cleansing at intervals, and in some cases it is the custom to replace the inner globe by a clean one every time the lamp is recarboned.

The shielding of the arc from the movements of the outer air enables a much greater length of arc to be employed than would otherwise be practicable. The ordinary pressure at carbons employed in direct-current enclosed-arcs is from 80 to 85 volts, instead of about 45 volts in open arcs. Moreover, on 220-volt direct-current

circuits, enclosed arc-lamps are frequently operated with a potential difference between the carbons, of 150 volts, and a distance between the carbons of about $1\frac{1}{8}$ ". In some special cases arcs are carried with 200 volts between carbons. An approximate rule for finding the length, in hundredths of an inch, of direct-current enclosed-arcs for a given voltage between the carbons, is to subtract 45 from this voltage, so that a 145-volt arc would roughly have a length of 100 hundredths of an inch, or one inch. The length of an arc, either enclosed, or open, depends, however, not only upon the voltage between the carbons, but also upon the strength of current, and upon the quality of the carbons.

The 220-volt-circuit arc, with 150 volts between the carbons, is usually designed

to take a current of 2.5 to 3 amperes. At 2.5 amperes it consumes 550 watts at terminals, of which 375 are consumed in the arc. In many cases, however, two enclosed arc-lamps are operated in series from 220-volt mains, or five in series from 500-volt mains. In these cases an automatically operated cut-out is employed which, in case of accident to any lamp, substitutes in the series circuit a corresponding resistance of wire. These lamps ordinarily receive 5 amperes, and burn for 130 to 150 hours at one carboning.

The connections of a General Electric alternating-current, constant-potential, enclosed arc-lamp are seen in Fig. 161. *A* *C*, is the reactance coil, or choking coil, connected in series with the controlling magnets *m*, *m*, and the arc *a*. The reactance coil is tapped at six points marked

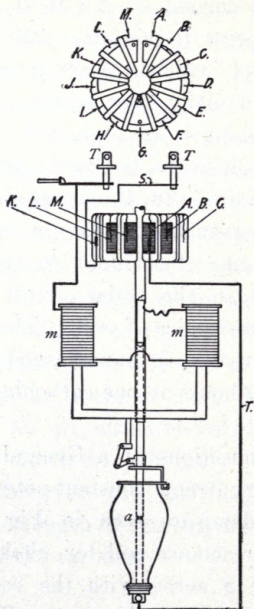

FIG. 161.—DIAGRAM FOR ADJUSTMENT OF ALTERNATING-CURRENT, CONSTANT-POTENTIAL ARC LAMP.

C , K , L , and M , for main voltages, increasing from 100 to 125 volts, while the lower carbon is connected either to the point A , or the point B , of the reactance coil, according as the frequency of the circuit is 60 or 125 cycles per second. T , T' , are the main terminals. Fig. 162, shows the connections of such lamps with the mains. p , p , are the primary mains, at either 1,040 or 2,080 volts pressure; T , is the step-down transformer; s , s , the secondary mains, to which incandescent or arc lamps may be individually connected. A double-pole switch and a double-pole fuse box are inserted between the mains and each enclosed arc-lamp.

Additional advantages incidental to the use of enclosed arc-lamps are reduced risk of fire from sparks, or incandescent portions of carbon, dropping from the arc-

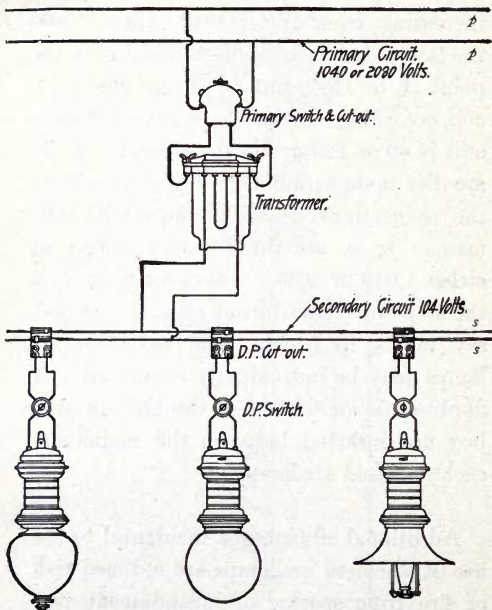

FIG. 162.—DIAGRAM OF CONNECTIONS.

lamp, greater steadiness of burning, so far as concerns the action of air currents, and the reduced brightness of the arc as a source of light, which by diffusion over a comparatively large surface of the outer globe, virtually divides the total emitted light over the enlarged surface of the outer globe, with a corresponding reduction of surface brightness. Consequently, the eye can rest without discomfort upon the outer globe, whereas it is pained by watching the naked arc in the ordinary open arc-lamp.

If we call the total quantity of light emitted in all directions from a point-source of a Hefner-Alteneck standard lamp, 12.566 Hefner-lumens, then the efficiency of constant-potential enclosed arc-lamps is usually about 4 Hefner-lumens per watt, at lamp terminals, with opalescent

outer globe; about 5 Hefner-lumens per watt with clear outer globe; and 6 Hefner-lumens per watt with no outer globe, the inner globes being slightly opalescent. Incandescent lamps at a consumption of 3 watts per candle have an efficiency of about 3.5 Hefner-lumens per watt, or not far below the efficiency of the doubly enclosed arc-lamp with opalescent globes, and with a steadying resistance coil in the circuit. On the other hand, the series open-arc-lamp may frequently have an efficiency of 17 Hefner-lumens per watt. In general, the efficiency of a direct-current enclosed arc is somewhat greater than that of an alternating-current enclosed arc of the same input, apparently owing to the difference between cyclic heating and steady heating of the carbon electrodes.

CHAPTER XIV.

SERIES ALTERNATING ARC-LIGHTING FROM CONSTANT-CURRENT TRANSFORMERS.

THE essential feature of the series arc-lighting system is necessarily the maintenance of a constant-current strength in the circuit; so that no matter how the number of lamps in the circuit may be varied, within the limits of the apparatus, the current and pressure at the terminals of any single lamp will remain constant. Consequently, in such a circuit the current is constant at all loads, or for all numbers of lamps operated; while the E. M. F. in the circuit varies proportionally to the number of lamps inserted in the circuit.

In Chapter XII., various dynamos have been described which are constructed in such a manner as to maintain approximately constant current under all variations of load, within the limits of their capacity. These dynamos supply either direct currents or alternating currents. It sometimes happens, however, that a large central station may be equipped with constant-potential alternating-current generators for its principal service. The introduction of series arc-lighting into the service of such a station necessitates either the introduction of a special class of constant-current generators, to supply the new demand, or some intermediate apparatus which shall transform from constant potential to constant current. Such an apparatus is furnished by the Thomson constant-current transformer.

The mechanism of one of these transformers is shown at Fig. 163.

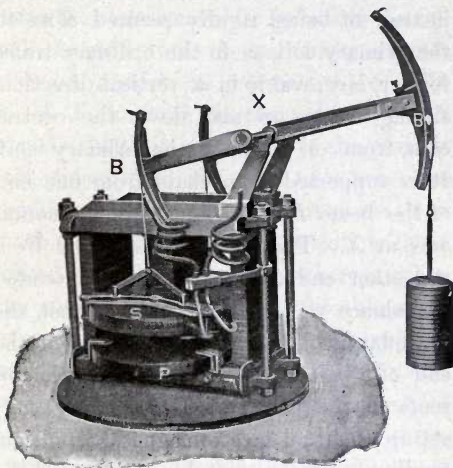

FIG. 163.—MECHANISM OF CONSTANT-CURRENT, ARC-LIGHTING TRANSFORMER.

The primary coil *P*, lies at the base, and receives the constant alternating primary

pressure, which is ordinarily either 1,100 or 2,200 volts. The secondary coil S , instead of being rigidly secured close to the primary coil, as in the ordinary transformer, is movable in a vertical direction, sliding freely up and down the central core, from or towards the primary coil. It is supported by a chain from one end of the beam BB , pivoted on a horizontal axis at X . The weights suspended from the other end of the beam are intended to balance the secondary coil, so that the secondary coil is supported freely at the end of a balance beam. The electric currents in the primary and secondary coils set up a mutual electromagnetic repulsion, tending to lift the secondary coil, or aid the gravitational pull of the weights. Consequently, if the induced secondary current is too strong, the electromagnetic force will raise the secondary coil. If, on the other

hand, the secondary current is too weak, the weight of the secondary coil will overcome the electromagnetic force, and the coil will descend until the secondary current strength regains its normal value. The E. M. F. induced in the secondary coil increases with its proximity to the primary coil, since, when the two coils are close together, nearly all the magnetic flux established by the primary coil will be linked with the secondary; whereas, when the secondary coil is lifted far above the primary, the magnetic leakage through the intervening air space will rob the secondary coil of a considerable amount of magnetic flux, and, therefore, of a correspondingly considerable amount of induced E. M. F. Under these conditions, the secondary coil, aided by the adjustment of the curves on the ends of the balance beam, always tends to assume such an

elevation and distance from the primary coil, that the current strength in the secondary coil shall be constantly that required for the operation of the arc-lamps in the series circuit. This current strength is usually 6.6 amperes.

The whole apparatus is placed inside the tank represented in Fig. 164, which is filled with oil, so that the secondary coil rises and falls in oil. This oil not only maintains good insulation, but also tends to damp out mechanical oscillations which might otherwise be set up. The walls of the tank are sometimes corrugated, so as to expose a greater convective surface for the liberation of the heat unavoidably wasted in the apparatus. A constant-current transformer of this type can be readily constructed to maintain a closer automatic adjustment to constant current under varying loads,

than can the ordinary constant-potential transformer maintain constant potential.



FIG. 164.—EXTERNAL VIEW OF CONSTANT-CURRENT ARC-LIGHTING TRANSFORMER.

These constant-current transformers are usually constructed in sizes of 25-light, 50-light, 75-light, and 100-light capacity,

about 80 volts being allowed on the average per lamp at the secondary terminals with 6.6 amperes, or about 528 volt-amperes in the secondary circuit per lamp, at a mean power-factor of, approximately, 0.8, or 422 watts per lamp. The current supplied on the primary side is practically constant at all loads. Since the primary pressure is also constant, the apparent power, or volt-amperes, supplied from the primary circuit, is also nearly constant, the real power varying with the load in the secondary circuit by the automatic adjustment of the phase-difference between the primary pressure and current; *i. e.*, the automatic adjustment of the primary power-factor.

In the larger sizes of these transformers, there are two fixed primary coils, one at the top and the other at the bottom of the

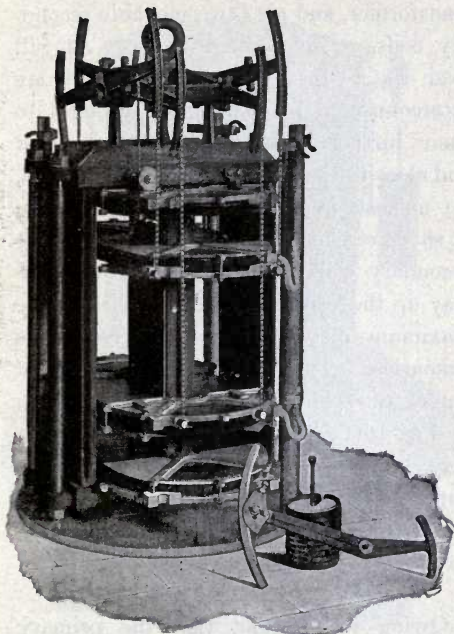

FIG. 165.—MECHANISM OF CONSTANT-CURRENT ARC-LIGHTING TRANSFORMER.

transformer, and also two movable secondary coils, as shown in Fig. 165. At full load the two secondary coils, which are interconnected by chains, are brought to their furthest distance from each other and close to their respective primary coils. At no load in the secondary circuit, *i. e.*, at short circuit in the secondary, the two secondary coils are brought together, half-way up the core, so as to be placed at the maximum distance from their respective primaries. The external appearance of one of these larger transformers is shown in Fig. 166. The two secondary circuits may be operated either in series, or in parallel, as desired. Fig. 167, shows the connections of one of these transformers, having two separate secondary circuits.

Owing to the fact that the primary power factor necessarily becomes about 33

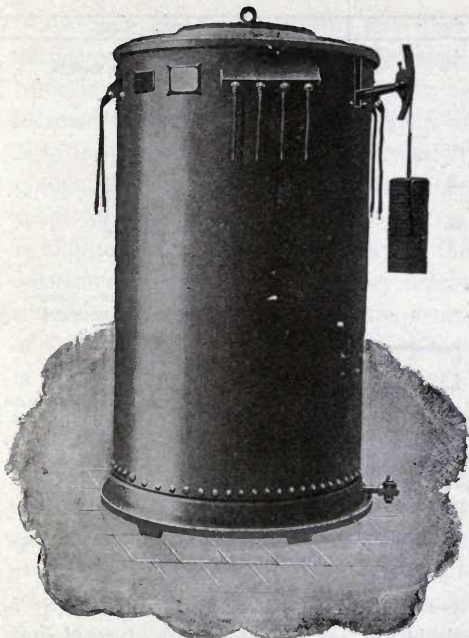

FIG. 166.—CONSTANT-CURRENT ARC-LIGHTING
TRANSFORMER COMPLETE.

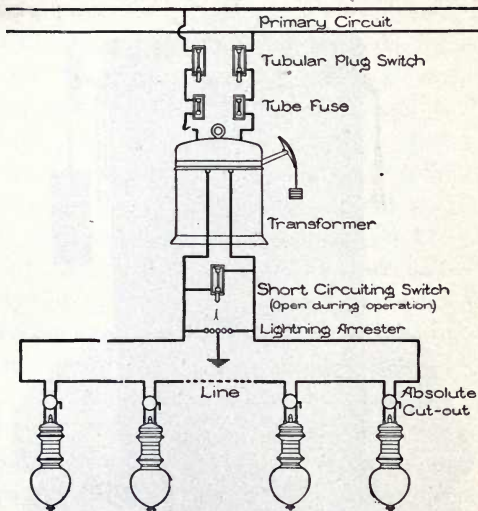

FIG. 167.—CONNECTIONS OF CONSTANT-CURRENT ARC-LIGHTING TRANSFORMER.

per cent. at 40 per cent. of full load, it is desirable to operate these transformers under nearly full load, when their power

factor may be 75 per cent., and their efficiency over 90 per cent. The apparatus is usually designed so as slightly to increase the secondary volts per lamp at light loads, owing to variations necessarily produced, under variations of load, in the shape of the alternating-current waves. In this manner the watts per lamp in the secondary circuit may be kept very nearly constant under all loads. The frequency of the currents supplied in such a system is usually 60 cycles per second.

The practical advantage of such transformers, when operating under satisfactory conditions of distribution, lies in the fact that the apparatus requires very little attention, and may be placed in a sub-station at a considerable distance from the main power-house. If a motor-dynamo were substituted for a constant-

current transformer under such conditions, it would usually be necessary to provide the services of an attendant in the sub-station.

The power-factor of an alternating-current arc-lamp, as measured at its terminals, is always less than unity, or 100 per cent., if only on account of the fact that the regulating magnet coils of the lamp, as well as the choking coil, in series with the arc, possess inductance, and bring about a lag in the current, or a wattless component of current. Moreover, even if we consider the power delivered to an alternating-current arc at the carbons, and thus eliminate the effect of inductance in the regulating coils, it is found that the power-factor is less than unity, or the watts in the arc at carbons are less than the volt-amperes. The power-factor of the

arc itself may, in fact, be as low as eighty per cent. under certain conditions. The arc has neither inductance nor capacity, and, consequently, the current through the arc neither leads nor is led by the pressure at carbons. The alternating-current waves cross the zero line, or vanish cyclically, at the same instants as the waves of P. D. between carbons. The waves of current have, however, a different shape to the waves of potential difference, which would not be the case if the arc acted like a simple resistance of metal wire. The resistance of the arc varies in fact with the current that passes through it, being relatively small with strong currents and great with weak currents. Consequently, if we force a simple sinusoidal wave of current through the arc, the P. D. will become magnified during the intervals of feeble current,

and the wave of alternating P. D. at the carbons will be double-peaked, or will have a depression at the place where the crest should appear. Conversely, if the conditions of the circuit are such as to impose a simple sinusoidal wave of E. M. F. at the carbons, then the current which will flow through the arc at the crests of the waves, will be relatively more powerful than the currents which flow through the periods of ascent and descent, so that the current wave will be sharply peaked.

A sinusoidal wave is the simplest type of alternating wave. It is so called because, when depicted graphically, the elevation at each point of the wave is proportional to the *sine* of the distance along the axis measured from the zero-point or point of mean level. It corresponds in contour to an ocean wave in deep water.

When a series of alternating-current lamps is supplied from a constant-current transformer at full-load, or with all the lamps in circuit, the inductance of the secondary coils of the transformer, which are close to the primary winding, is comparatively small, and the secondary waves of E. M. F. are nearly faithful copies of the waves of primary E. M. F. supplied by the generator. Assuming that the generator gives a nearly sinusoidal wave, then the E. M. F. at lamp terminals will be nearly sinusoidal, but the currents in the lamps will tend to differ considerably from sine waves, or will be centrally elevated into peaked waves. On the other hand, at very light loads, or with a small number of lamps in the circuit, the secondary coils will develop a considerable inductance, and this inductance will tend to smooth out the current-waves, and force

a more nearly sinusoidal type of current-wave upon the circuit. Under these conditions the E. M. F. developed in the secondary coil will flatten or tend to become double-humped. Consequently, the shapes of the waves of current and potential in such an arc-light circuit tend to undergo variation with change of load.

CHAPTER XV.

MULTI-CIRCUIT ARC-LIGHT GENERATORS.

THE modern tendency of development in the electric generation of power is towards larger sizes and powers of machinery; *i. e.*, larger generating units. Whereas, only a few years ago, in constant-potential systems a 50-KW. generator was regarded as a large unit, and a central station was an aggregation of a number of such units, at the present time a 500 KW. machine is regarded as a comparatively small unit. The same tendency has manifested itself in arc-lighting generators, but here progress has been retarded by reason of the fact that, with constant-

current machines, any increase in capacity is necessarily accompanied by a further increase in the terminal voltage. This terminal voltage is limited not merely by structural difficulties, but also by difficulties of circuit insulation. Thus a 10-ampere constant-current generator of 10-KW. capacity would have a full-load terminal pressure of 1 kilovolt, while a 70-KW. generator of the same type would have a full-load pressure of 7 kilovolts.

In order to keep the terminal pressure within convenient limits, the expedient has of recent years been adopted of dividing the armature coils of a generator into several groups, each of which forms electrically a separate armature, and is connected to a separate commutator and external circuit. Such a machine is called a *multi-circuit machine*, and the total voltage is

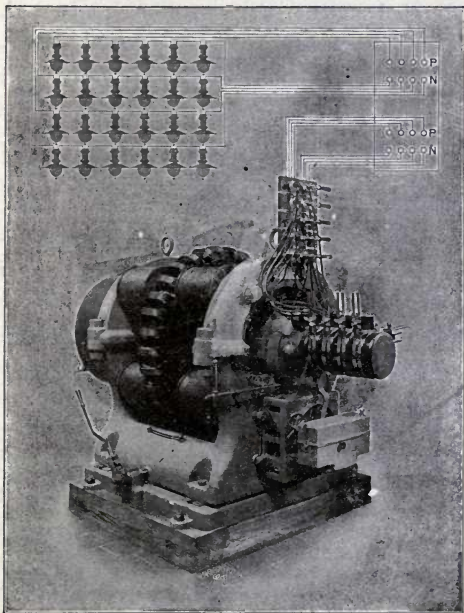

FIG. 168.—MULTI-CIRCUIT, 4 CIRCUITS, SHOWING THE GENERATOR, SWITCHBOARD, AND THE DIFFERENT LAMP CIRCUITS.

divided among the separate circuits. A 4-circuit Brush arc generator is represented in Fig. 168. Here the head board of the machine carries five single-pole switches. One of these switches short-circuits the field magnets, and, therefore, acts as the main switch for the machine. Each of the four remaining switches short-circuits a group of armature coils and an external circuit. Consequently, any number of circuits, up to four inclusive, can be operated simultaneously through the intermediate switch-board, diagrammatically indicated at *S*. These machines are either belt-driven or direct-driven, and are at present constructed in sizes up to 76 KW. in two-circuit, three-circuit, or four-circuit types. These machines are developments of the type of single-circuit generator already shown in Figs. 145 and 146.

CHAPTER XVI.

PHOTOGRAPHY BY THE ARC-LIGHT.

IN the ordinary operation of blue-printing, the paper is placed below the tracing and exposed to ordinary sunlight. Not only is this process dependent upon fine weather for its maintenance, but it is also dependent upon securing a proper exposure. In large office buildings a suitable exposure to sunshine is sometimes difficult to obtain, and in some localities the local conditions may preclude the possibility of the exposure ever being obtained. The electric arc-lamp permits blue-printing to be carried on independently of weather and exposure to sunshine, arc-light being

capable of replacing sunlight for photographic work. Although the time of exposure to arc-light is considerably in excess of the time of exposure to bright sunlight, yet the uniformity with which conditions can be reproduced in the case of arc-lighting, enables prints to be obtained with a greater degree of certainty and precision than is possible with sunlight, under the ordinary varying conditions of cloud and atmospheric absorption. A more sensitive and rapid blue-print paper is also employed with arc-lamps, in order to lessen the time necessary for exposure.

A general view of a standard equipment for electric blue-printing is shown in Fig. 169, and Fig. 170 shows the same equipment dismantled. A pair of arc-lamps, of the enclosed arc type, are sup-

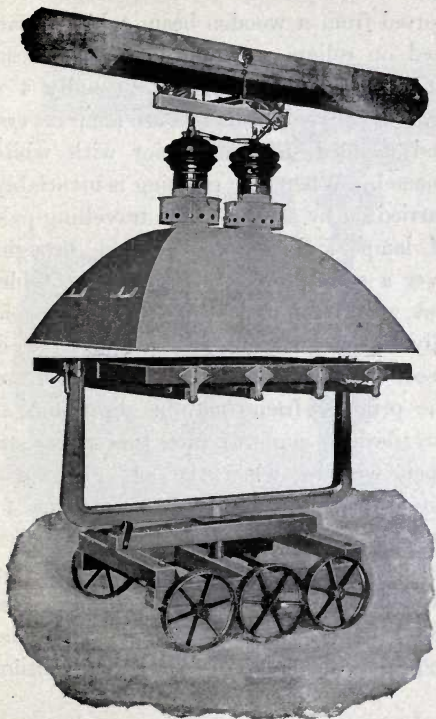

FIG. 169.—EQUIPMENT FOR ELECTRIC BLUE-PRINTING.

ported from a wooden beam, which is carried on rollers movable on an overhead rail. A large hood reflector, usually 4' x 3', is supported from the arc lamp covers, and is lined on the interior with white enamel. Where the printing is invariably carried on by arc-light, this travelling pair of lamps and reflector can be brought over a suitable fixed flat printing table, but where resort may be made occasionally to sun printing, a movable table is used, which is shown in Fig. 169. Here the printing frame may be supported at any desired angle to face the sun at an open window, when the arc-light apparatus is not in use. It is customary to employ a more sensitive and rapid blue-print paper in such a printing frame for arc-light printing, and the ordinary less rapid paper for sun printing. The time required for exposure in arc printing

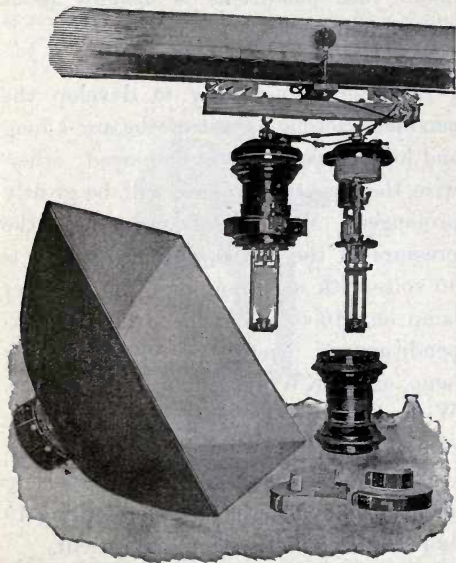

FIG. 170.—ARC LAMPS AND HOOD SHOWING USUAL METHOD OF SUPPORT.

under such conditions is usually about three minutes.

In order conveniently to develop the maximum actinic power of the arc, a long and high-pressure arc is employed; otherwise, the time of exposure will be greatly prolonged. With direct-current arcs, the pressure of the arc as ordinarily used, is 80 volts with a current of 5 amperes per lamp on 110-volts circuit, making an expenditure of energy of 550 watts per lamp, or 1.1 KW. for a double-lamp frame. With alternating-current supply, the pressure of the arc is ordinarily 73 volts effective, with a current of 7.5 amperes per lamp and 104 volts at terminals, representing 15 amperes for a double-lamp equipment.

In some cases a vertical cylindrical printing frame is employed with a glass

surface inside, and an arc-lamp is automatically lowered at a steady rate down the axis of the cylinder.

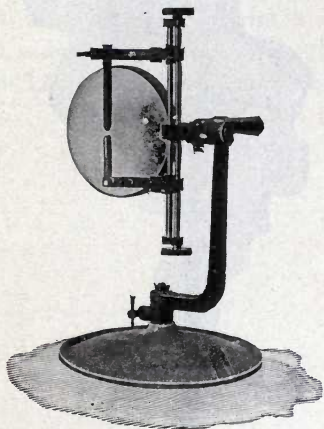

FIG. 171.—STANDARD HAND-FEED LAMP.

For photographic reductions or enlargements, a type of arc lamp is sometimes employed which is either hand-fed, as shown

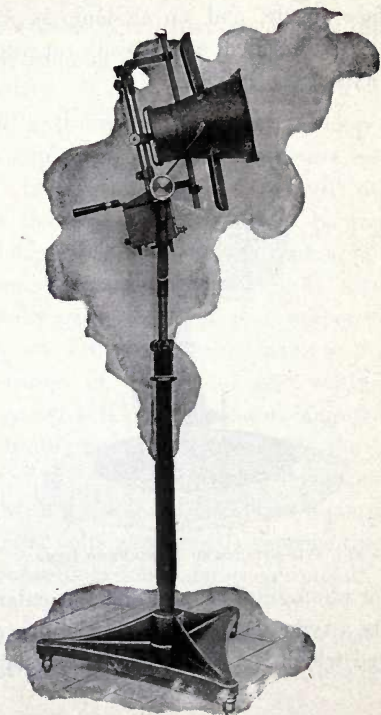
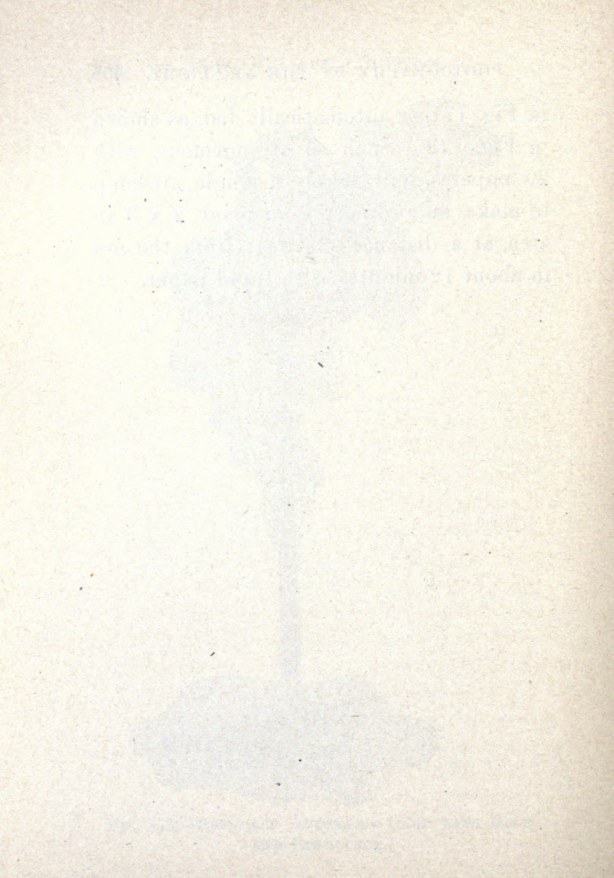

FIG. 172.—STANDARD AUTOMATIC LAMP WITH HOOD
AND REFLECTOR.

in Fig. 171, or automatically fed, as shown in Fig. 172. Such an arrangement, with 20 amperes, will enable a single arc-lamp to make an ordinary blue-print 2' x 3' in area, at a distance of 4 feet from the arc in about 12 minutes with rapid paper.



INDEX.

A

- Absorption of Light by Globes, 205.
- Activity, Definition of, 52.
- , Electrical Unit of, 53.
- , Unit of, 52.
- Adjustable Arc Lamp Hanger, 172.
- All-Night Arc Lamp, 118.
- Arc Lamp, Wallace, 121, 122. ?
- Elliptical Carbon Lamp, 126, 127.
- Lamps, Series-Connected, 117 to 136.
- Reciprocating Carbon Lamp, 128.
- Alternating Carbon Arc, Electromotive Force
Required for, 212 to 218.
- Current Arc Lamps, 209 to 236.
- Current Arc Lamps, Circuit Connections
for, 219, 220.

- Alternating-Current Arc Lamps, Influence of Frequency on, 209, 236.
- Current Arc Lamps, Mechanism for, 212 to 218.
- Current Arc Lamps, Methods for Connecting, 221, 222.
- Current Arc Light, Distribution of, 258.
- Current Arcs, 34.
- Current Constant-Potential Enclosed Arc-Lamp, 365, 366.
- Current Constant-Potential Lamp, Forms of, 230, 231.
- Current Generator, 345.
- Current Lamp-Mechanism, Circuit Connections of, 216.
- Current Transformer, 217.
- Electric Currents, 34.
- Alternator, 217.
- Alternators, 325.
- , Self-Excited, 325.
- Amount of Work, How Measured, 50.
- Ampere, Definition of, 46.
- Analogy of Electric Current and Water Current, 38, 39.
- Apparent C. E. M. F. of Arc, 75.

- Arc Circuit, Total Resistance of, 77, 78.
- , Carbon, 18.
- , Carbon, Probable Temperature of, 30.
- , Carbon Voltaic, Physical Characteristics of, 23, 24.
- Carbons, Equal Consumption of, with Alternating Currents, 35.
- Carbons, Unequal Consumption of, with Continuous Currents, 35.
- , Causes of Unsteadiness of Light from, 26.
- , Effect of Distance between Carbons on, 82.
- Lamp, Ash Pan for, 321.
- Lamp, Candle Power of, 259.
- Lamp Carbons, 307 to 322.
- Lamp Circuit, Series, Diagram of Connections of, 108, 109.
- Lamp, Cross-Wire Suspension, 173.
- Lamp, Dash-Pot for, 105.
- Lamp, Derived-Circuit, 89.
- Lamp, Diffusing Reflector for, 264.
- Lamp, Double-Carbon, 129.
- Lamp for Diffused Lighting, 263.
- Lamp for Lantern Projection, 294.
- Lamp for Photo-Engraving, 305.

- Arc Lamp Hanger-Board, 181.
- Lamp Hangers, 189, 190.
- Lamp, Inner Globe of, 357.
- Lamp Mechanism, 55 to 125.
- Lamp Mechanism, Series Magnet for, 86.
- Lamp Mechanism, Shunt Magnet for, 86.
- Lamp Mechanism, Forms of, 89 to 103.
- Lamp, Pole Support for, 179.
- Lamp Poles, Forms of, 182, 183.
- Lamp Projectors, 57.
- Lamp, Projectors for, 268 to 306.
- Lamp, Ring Clutch for, 106.
- Lamp, Shunt and Series Magnets of, 74.
- Lamp, Siemens' Later Form of, 93.
- Lamps, Alternating-Current, 209, 236.
- Lamps, Constant-Potential, 137 to 162.
- Lamps, Constant-Potential, Connections of,
147, 148, 150.
- Lamps, Enclosed, 356 to 374.
- Lamps, Focusing, 267.
- Lamps, Mast-Arm Support for, 184, 185.
- Lamps, Multiple Connection of, 63.
- Lamps, Series Connection of, 61.
- Light Carbons, 7.
- Light Carbons, Cross Sections of, 319.

- Arc Light Carbons, Various Dispositions of, 59.
- Light Circuit, Lightning Arrester for, 208.
- Light Circuits, Parallel, 60.
- Light Circuits, Series, 60.
- Light Dynamos, Series, 329.
- Light Generator, Multi-Circuit, 393 to 396.
- Light Generators, 339 to 341.
- Light Globes, Forms of, 204.
- Light Main-Circuit Magnet, 86.
- Light Photography, 397 to 405.
- Light Regulator, Siemens' Early Form of, 88.
- Light Regulators, 5.
- Light Regulators, Automatic, 5, 6.
- Light Transformers, Connections of Primary Circuits of, 23, 232.
- Lighting Central Station, 350, 351.
- Lighting, Early History of, 1 to 15.
- Lights on Incandescent Circuits, 142 to 146.
- , Metallic, 18.
- , Ohmic Resistance of, 84.
- Resistance, Circumstances Affecting, 79 to 81.

- Arc, Resistance of, 78.
——, Travelling of, 316.
——, Voltaic, 16 to 36.
——, Voltaic, Causes of Flickering of, 26.
——, Voltaic, Counter-Electromotive Force of,
75.
—— Voltaic, Temperature of Positive Crater, 28.
——, Alternating, 34.
——, Continuous-Current, 34.
Archereau's Regulators, 66.
Armature of Alternator, 346, 347.
Artificial Carbons, Bunsen's Process for, 310.
—— Graphite, 34.
Ash-Pan for Arc Lamp, 321.
Atoms, 239.
Automatic Arc-Lamp Regulators, 54.
—— Arc-Light Regulators, 5, 6.

B

- Bare Carbons, 316.
Battery, Voltaic, 45.
Beam of Light, 242.
Belt-Driven Generators, 348.

- Bipolar Type, Continuous-Current Arc-Light Generator, 330.
——— Continuous-Current Generator, 326, 327.
——— Dynamo-Electric Machine, 324.
——— Gramme-Ring Arc-Light Generator, 331, 332.
- Blue-Printing, Electric, 398 to 400.
- Board-Hanger for Arc Lamp, 171.
- Bongie-Decimale, 252.
- Bongie-Metre, 253.
- Box, Olivette, 302.
- British Standard Sperm Candle, 248.
- Brush Double-Carbon Lamp, 131.
- Brush Washer or Ring Clamp, 130.
- Bunsen, 6.
——— Process, 310.

C

- C. E. M. F., Apparent, of Arc, 75.
——— of Arc, 75.
- Candle, British Standard Sperm, 248.
- Candle, Jablochkoff, 10 to 15.
- Candle-Foot, 253.
- Candle-Power of Arc Lamp, 259.

- Carbon Arc, 18.
- Arc, Causes of Shifting of, 25.
 - , Ebullition of, in Voltaic Arc, 27.
 - Electrodes, Various Positions of, 59.
 - Holders, 320, 321.
 - Vapor, Condensation of, on Negative Carbon, 31.
 - Voltaic Arc, 5.
 - Voltaic Arc, Characteristics of, 20, 21.
 - Voltaic Arc, Nipple of, 20, 22.
 - Voltaic Arc, Principal Source of Light of, 23.
 - , Volatilization of, in Voltaic Arc, 27.
- Carbonizing Process, 308, 309.
- Carbons, Arc-Light, 7.
- , Arc-Light, Cross Sections of, 319.
 - , Bare, 316.
 - , Circumstances Affecting Density of, 315, 316.
 - , Coppered, 316.
 - , Cored, 316.
 - , Cored, for Arc Lights, 27.
 - , Coreless, 319, 320.
 - , Effect of Impurity of, on Light of Arc, 313.
 - , for Enclosed Arc-Lamps, 367.

- Carbons, Firing Process for, 315, 316.
——— for Arc Lamps, 307 to 322.
———, Influence of Nature of, on Quietness of
 Arc, 322.
———, Life of, 320.
———, Long-Lived, 320.
———, Moulding Process for, 314.
———, Rate of Consumption of, in Enclosed Arc-
 Lamps, 358, 359.
———, Solid, 316.
———, Squirting Process for Incandescing, 314.
- Carcel Colza Oil Lamp, 249.
- Carré, 312.
- Ceiling Suspension for Arc Lamp, 176.
- Cells, Voltaic, Double-Fluid, 6.
- Central Station, Switchboard for, 352, 353.
- Characteristic Bow-Shape of Arc, Cause of, 32.
- Characteristics of Carbon Voltaic Arc, 20, 21.
- Choking Coil, 218.
- Circuit Arrester for Arc Lights, 208.
———, Break, Insulators, 177, 178.
——— Connections of Alternating-Current Arc
 Lamp, 219, 220.
——— Connections of Alternating-Current, Arc-
 Lamp Mechanism, 216.

- Circuit, Electric, 37.
——, Hydraulic, 40.
——, Primary, of Transformer, 218.
——, Secondary, of Transformer, 218.
Circuit, Shunt or Derived, 70, 71.
——, Shunt, Principle of, 72.
Circuits, Parallel Arc-Light, 60.
——, Series Arc-Light, 60.
Circular Hangers for Arc Lamps, 191, 192, 193.
Circumstances Affecting Resistance of Arc, 79 to 81.
Coil, Choking, 218.
——, Economy, for Alternating-Current Arc-Lamp, 222 to 225.
——, Economy, for Alternating-Current Arc-Lamp, Connections for, 224.
——, Resistance, 218.
Color, Cause of, 243.
—— of Light, 241.
—— Value of Sunlight, 244.
Condensation of Carbon Vapor on Negative Carbon, 31.
Constant-Current Arc-Lighting Transformer, Thomson's, 376 to 387.
—— Current Transformers, Series-Alternating Arc-Lighting, 375 to 392.

- Constant-Potential Arc-Lamps, Connections of,
147, 148, 150.
- Lamps, 137, 162.
- Continuous-Current Arc-Lamp, Distribution of
Luminous Intensity of, 256.
- Dynamo Electric Machine, 325.
- Current Arcs, 34.
- Electric-Current, 34.
- Controlling Gear for Arc-Light Projector, 282.
- Coppered Carbons, 316.
- Core, Laminated, of Transformer, 227.
- Cored Carbons, 316.
- Carbons for Arc Lights, 27.
- Coreless Carbons, 319, 320.
- Coulomb, Definition of, 47.
- Counter-Electromotive Force of Voltaic Arc,
75.
- Crater of Carbon Voltaic Arc, 21.
- of Voltaic Arc, Temperature of, 28.
- Cross-Wire Suspension for Arc Lamp, 173.
- Crucibles, Electric, 33.
- Current, Continuous Electric, 34.
- , Electric, Definition of, 46.
- Strength, Definition of, 28.
- Currents, Alternating Electric, 34.

Cut-Out Switches for Arc-Light Circuits, 194 to 198.

Cylinder, Damping, for Arc Lamps, 105.

D

Damping Cylinder for Arc Lamps, 105.

Dash-Pot for Arc Lamp, 105.

Davy, 307.

———, Alleged Discovery of Voltaic Arc by, 4.

Daylight, Colors of, 244.

De Mersanne, 119, 120.

Density of Carbons, Circumstances Affecting, 315, 316.

Derived-Circuit Arc Lamp, 89.

——— or Shunt Circuit, 70, 71.

Device, Gripping, for Arc Lamp, 88.

Diagram of Connections of Arc-Light Generator, 333.

——— of Connections of Series Arc-Light Circuit, 108, 109.

Differential Lamp, 89.

Diffused Lighting, Arc Lamp for, 263.

——— Reflector for Arc Lamp, 264.

- Diffusing Globe for Arc Lamp, 266.
Direct-Coupled Generator, 350.
Direct-Driven Generators, 349.
Double-Carbon Arc Lamp, 129.
—— Arc-Lamp Mechanism, 132, 133.
Double-Fluid Voltaic Cells, 6.
Drop of Pressure of Arc, 75.
Dynamo Electric-Machine, 45.
—— Machine, Continuous-Current, 324.
—— Machines, 62.
Dynamamos, 355.

E

- E. M. \mathcal{F} ., Meaning of, 38.
Early History of Arc Lighting, 1 to 15.
Ebullition of Carbon in Voltaic Arc, 27.
Economy Coil for Alternating-Current Arc-Lamp,
222 to 225.
—— Coil-for Alternating-Current Arc-Lamps,
Connections for, 223.
Edwards, 311.
Efficiency, Luminous, 246.
Electric Arc-Light Tower, 188.

- Electric Blue-Printing, 398 to 400.
- Circuit, 37.
 - Crucibles, 33.
 - Current, Definition of, 46.
 - Furnaces, 33.
 - Light Photographic Reductions or Enlargements, 403, 404.
 - Light Tower, 188.
 - Quantity, Unit of, 47.
 - Resistance, 41.
 - Sources, 37.
 - Stereopticon, 295.
- Electrical Unit of Activity, 53.
- Electricity, Quantity of, 41.
- Electrode, Positive, Crater in, 21, 22.
- Electrodes, Carbon, Various Positions of, 59.
- Electromotive Force, 37.
- Force, Unit of, 44.
- Elliptical All-Night Carbon Lamp, 126, 127.
- Enclosed Arc-Lamp, Rate of Consumption of Carbons in, 358 to 359.
- Arc-Lamps, 356 to 374.
 - Arc-Lamps, Advantages of, 360.
 - Arc-Lamps, Automatic Cut-Outs for, 369, 370.

- Enclosed Arc-Lamps, Carbons for, 367.
—— Arc-Lamps, Length of Arc in, 367, 368.
—— Arc-Lamps, Luminous Efficiency of,
373, 374.
Equal Consumption of Arc Carbons with Alter-
nating Currents, 35.
Ether Vibrations, Range of Frequency of, 240.

F

- Faraday, 9.
Feeding Mechanism, Requisites for Proper Opera-
tion of, 58.
Flickering of Voltaic Arc Light, Causes of, 26.
Fire-Fly, Light of, 247.
Fire Island Lighthouse Lens, 291.
Flashing Light for Lighthouses, 293.
Flux, Magnetic, 323.
—— of Light, Unit of, 251.
Focusing Arc Lamps, 267.
—— Lamp, Automatic, 270.
—— Lamp, Automatic, Vertical, 272.
—— Lamp for Lighthouse, 293.
—— Lamp, Necessity for, 269.
—— Lamps, Varieties of, 273.

- Foot-Pound, Definition of, 50.
—— per-Second, 52.
Force, Electromotive, 37.
Forms of Arc-Lamp Mechanism, 95 to 103.
Foucault, 8, 307.
Frame, Side, of Arc Lamp, 174.
Frequency, Influence of, on Alternating-Current
Arc-Lamps, 209 to 236.
Furnaces, Electric, 33.

G

- Generator, Alternating-Current, 345.
——, Belt-Driven, 348.
——, Bipolar, Continuous-Current, 326, 327.
——, Direct-Coupled, 350.
——, Direct-Driven, 349.
——, Multi-Circuit Arc, 393 to 396.
Generators, 62.
——, Magneto-Electric, 9.
——, Railway, 46.
Globe, Influence of, on Intensity of Arc Light,
262.
Globes, Absorption of Light by, 205.

- Globes for Arc Lights, Forms of, 204.
Gramme, 9.
Graphite, Artificial, 34.
Gripping Device for Arc Lamp, 88.
Grove, 6.

H

- Hanger Board for Arc Lamp, 171, 181.
—— Board Hood, 199.
—— Boards, 191, 192, 193.
Hangers for Arc Lamps, 189, 190.
Harrison, 8.
Harrison's Arc Lamps, 125, 126.
Head-Light for Locomotives, 292.
Hefner-Alteneck Amyl-Acetate Lamp, 249.
Holder, Jablochhoff's Candle, 17, 18.
Holders for Carbons, 320, 321.
Hood and Hanger Board, 199.
—— for Arc-Lamp Suspension, 200, 203.
Hoods for Arc Lamps, 199 to 203.
Horse-Power, Definition of, 52.
Hydraulic Circuit, 40.

I

- Igniter of Jablochkoff's Candle, 14.
Illumination and Light, 237 to 267.
—— by Moonlight, 1, 2.
——, Lighthouse, 293.
——, Practical Unit of, 252.
——, Unit of, 250.
Incandescent-Circuit Arc Lights, 142 to 146.
Infra-Red Light, 240.
Inner Globe of Enclosed Arc-Lamp, 357.
Insulators, Circuit Break, 177, 178.
——, Circuit Loop, 177, 178.
Intensity, Maximum, of Light, 255, 256, 257.
—— of Horizontal Light, 255, 256, 257.
—— of Light, 259.
Iron Wire Arc-Light Globe Netting, 206.

J

- Jablochkoff's Candle, 10 to 15.
—— Candle Holder, 17, 18.
—— Candle, Igniter of, 14.
—— Candle, Use of Alternating Currents for,
14.

Jacquelain, 312.

Joule, Definition of, 50, 51.

—— per-Second, 53.

L

Lacassagne and Thiers, 70, 311.

Laminated Core of Transformer, 227.

Lamp, Arc, 450-Watt, 45-Volt, 261.

——, Carcel Colza Oil, 249.

——, Derived Circuit, 89.

——, Differential, 89.

——, Focusing, Varieties of, 273.

—— Frame with Inside Globe, 207.

—— Frame with Outside Globe, 207.

——, Hefner-Alteneck Amyl-Acetate, 249.

—— Rod, 87.

——, Twin-Carbon, 129.

——, Violle Platinum Standard, 249.

Lamps, All-Night Series-Connected, 117 to 136.

——, Arc, Hoods for, 189 to 203.

——, Search Light, 274 to 279.

——, Search, Simple Form of, 275, 276.

Lantern Projector, Arc Lamp, 294.

- Law, Ohm's, 48.
- Leads, Negative, 63.
- , Positive, 63.
- Length of Arc in Enclosed Arc-Lamps, 367, 368.
- Le Molt, 8, 311.
- Life of Carbons, 320.
- Light, Actinic Power of, 241.
- and Illumination, 237 to 267.
- , Beam of, 242.
- , Color of, 241.
- , "Dark," 240.
- , Diffusing Arc Lamp Globe, 266.
- , Flux, Unit of, 251.
- , Focusing for Lighthouses, 293.
- , Frequency of Vibration of, 240.
- , Infra-Red, 240.
- , Intensity of, 259.
- , Mean Spherical Intensity of, 256.
- , Objective Cause of, 237, 238.
- of Fire-Fly, 247.
- , Spectrum, 242.
- , Standard Source of, 248.
- , Two-Fold Use of Word, 237.
- , Ultra-Violet, 240.
- , Unit of, 249.

- Light, Velocity of, 242.
Lighthouse Illumination, 293.
——— Lens, Fire Island, 291.
Lighthouses, Flashing Light for, 293.
Locomotive, Electric Headlight for, 292.
Long-Lived Carbons, 320.
Lumen, 251.
Luminous Efficiencies, Table of, 246.
——— Efficiency, 246.
——— Efficiency of Enclosed Arc-Lamps, 373,
374.
Lux, 253.

M

- Machine, Bipolar Dynamo-Electric, 324.
———, Dynamo-Electric, 45, 62.
Magnet, Main-Circuit Arc Light, 86.
Magnetic Cause of Bow-Shape of Voltaic Arc, 32.
——— Flux, 323.
Magneto-Electric Generators, 9.
Main-Circuit Arc-Light Magnet, 86.
Mangin's Projector for Search Light, 289.
——— Reflector, 290.
Marine Search Light Projector, 283.
Mast-Arm Support for Arc Lamps, 184, 185, 186.

- Maximum Intensity of Light, 255, 256, 257.
Mean Spherical Intensity of Light, 255, 257.
Mechanism, Arc-Lamp, 55 to 115.
——— for Alternating-Current Arc Lamps, 212 to 218.
——— of Double-Carbon Arc Lamps, 132, 133, 134.
Melting Points of Refractory Metals, 29.
Metals, Refractory, Melting Points of, 29.
Metallic Arc, 18.
Microhm, Definition of, 43.
Molecules, 239.
Moonlight, Illumination by, 1, 2.
Moulding Process for Carbons, 314.
Multi-Circuit Arc-Light Generators, 393 to 396.
Multi-Circuit Generator Switchboard and Lamp Circuit of, 394 to 396.
Multiple Connection of Arc Lamps, 63.
——— and Series Distribution, Influence of, on Weight of Conducting Circuit, 139 to 142.

N

- Negative Arc-Light Carbons, Rate of Consumption of, 118.

Negative Carbon of Voltaic Arc, Lower Temperature of, 31.

——— Leads, 63.

——— Pole of Electric Source, 38.

Nipple on Carbon Voltaic Arc, 20, 22.

Nollet, 9.

O

Ohm, Definition of, 42.

Ohm's Law, 48.

Ohmic Resistance of Arc, 84.

Oil-Insulated Transformer, 228, 229.

Olivette Box, 302.

Outrigger and Hood for Arc Lamps, 169.

P

Parallel Arc-Light Circuits, 60.

——— Connection of Arc Lamps, 63.

Pencils, Arc-Light Carbon, 7.

Photo-Engraving, Arc Lamp for, 305, 306.

Photographic Reductions or Enlargements, Electric Light, 403, 404.

Photography, Electric-Light, 397 to 405.

- Physical Characteristics of Carbon Voltaic Arc,
23, 24.
- Pilot-House Controlling Gear for Projector, 282.
- Pilsen Arc Light, 123, 124.
- Pole, Negative, of Electric Source, 37.
- , Positive, of Electric Source, 37.
- Support for Arc Lamp, 179.
- Support for Arc-Lamp Hoods, 202, 203.
- Poles of Electric Source, 37.
- Positive Arc-Light Carbons, Rate of Consumption
of, 118.
- Electrode, Crater of, 20.
- Leads, 63.
- Practical Unit of Illumination, 252.
- Primary Circuit of Transformer, 218.
- Process, Carbonizing, 308, 309.
- Projectors, Arc-Lamp, 57 and 268 to 306.
- , Mangin's, 289.
- , Search Light, 278 to 289.

Q

- Quantity of Electricity, 41.
- of Electricity, Unit of, per Second, 46.
- Quietness of Arc, Influence of Carbons on, 322.

R

- Railway Generators, 46.
- Rate of Consumption of Negative Arc-Light Carbon, 118.
- of Consumption of Positive Arc-Light Carbon, 118.
- of Doing Work, 52.
- Range of Frequency of Ether Vibrations, 240.
- Reactance Coil of Enclosed, Alternating-Current Arc-Lamp, 365.
- Reciprocating Carbon All-Night Lamp, 128.
- Reflector, Mangin's, 290.
- , Stage, for Theatres, 296, 297.
- Refractory Metals, Melting Points of, 29.
- Regulators, Archereau's, 66.
- , Arc-Light, 5.
- , Automatic Arc-Lamp, 54.
- , Automatic Arc-Light, 5, 6.
- Reichsanstalt Standard, 249.
- Resistance Coil, 218.
- , Electric, 41.
- , Ohmic, of Arc, 84.
- of Arc, Circumstances Affecting, 79 to 81.

- Resistance of Arc, Effect of Counter Electromotive Force on, 84, 85.
—— of Arc, Effect of Current Strength on, 83.
——, Unit of Electric, 42.
Resistivity, Definition of, 43.
Rheostat for Projector, 287.
Ring Clutch for Arc Lamps, 106.
—— or Washer Clamp, 130.
Rod Lamp, 87.
Rods, Arc-Light Carbon, 7.

S

- Search Light Lamps, 274 to 279.
—— Lights, 57.
Secondary Circuit of Transformer, 218.
Self-Excited Alternators, 325.
Series and Multiple Distribution, Influence of, on
Weight of Conducting Circuit, 139 to 142.
—— Alternating-Current Arc-Lighting from
Constant-Current Transformers, 375 to
392.
—— Grouping of Alternating-Current, Constant-
Potential Enclosed Arc-Lamps, 370, 371.

- Series Arc-Lamp Circuit, Diagram of Connections of, 108, 109.
- Arc Lamp, Interior Mechanism of, 110 to 114.
- Arc-Light Circuits, 60.
- Arc-Light Dynamo, 329.
- Connected All Night Lamps, 117 to 136.
- Connection of Arc Lights, 61.
- Distribution, 139 to 142.
- Magnet for Arc-Lamp Mechanism, 86.
- Serrin, 8.
- Shifting of Carbon Arc, Causes of, Voltaic, 25.
- Shunt and Series Magnets of Arc Lamp, 74.
- Circuit, Principle of, 70, 71.
- Magnet for Arc-Lamp Mechanism, 86.
- or Derived Circuit, 70, 71.
- Side Frame of Arc Lamp, 174.
- Siemens' Arc Lamp, Later Form of, 93.
- Regulator, Early Form of, 88.
- Solenoid, 65.
- Solid Carbons, 316.
- Sounds, Characteristic, of Voltaic Arcs, 35, 36.
- Source, Standard, of Light, 248.
- Sources, Electric, 37.
- Squirting Process for Incandescing Carbons, 314.

- Stage Reflector Lamp for Theatres, 296, 297.
- Staite, 8, 311.
- Standard, Reichsanstalt, 249.
- Sources of Light, 248.
- , Vernon-Harcourt Pentane, 249.
- Station, Central, for Arc Lights, 250, 251.
- Step-Down Transformer, 223.
- Transformer, Details of Construction of, 226, 227.
- Stereopticon, Electric, 295.
- Sunlight Color Values, 244.
- Suspension, Cross-Wire, of Arc Lamp, 173.
- Hood for Arc Lamps, 169.
- , In-Door, for Arc Lamps, 176.
- Outrigger for Arc Lamps, 167, 168.
- and Lamp Circuit of Multi-Circuit Generator, 394 to 396.
- Switchboard, 351, 352.
- for Arc Lighting, 351 to 355.
- for Central Station, 352, 353.
- Switches, Cut-Out, for Arc-Light Circuits, 194 to 198.

T

- Table of Luminous Efficiencies, 246.

- Temperature at which Bodies Become Luminous, 30.
- Temperature of Crater of Voltaic Arc, 28.
- Theatre, Stage Reflector, Lamps for, 296, 297.
- Thomson's Constant-Current Arc-Lighting Transformer, 376 to 387.
- Tower, Electric Light, 188.
- Transformer, Alternating-Current, 217.
- , Laminated Core of, 227.
- , Oil-Insulated, 228, 229.
- , Primary Circuit of, 218.
- , Secondary Circuit of, 218.
- , Step-down, 223.
- Travelling of Arc, 316.
- Twin-Carbon Arc Lamps, 129.

U

- Ultra-Violet Light, 240.
- Unequal Consumption of Arc Carbons with Alternating Currents, 35.
- Unit of Activity, 52.
- of Electric Current, 46.
- of Electric Quantity, 47.
- of Electric Resistance, 42.

- Unit of Electrical Activity, 53.
—— of Electromotive Force, 44.
—— of Flux of Light, 251.
—— of Illumination, 250.
—— of Illumination, Practical, 252.
—— of Light, 249.
—— of Quantity of Electricity per Second, 46.
—— of Work, 50.
Use of Alternating Currents for Jablochhoff's
Candle, 14.

V

- Van Malderen, 9.
Velocity of Light, 242.
Vernon-Harcourt Pentane Standard, 249.
Vertical Automatic Focusing Lamp, 272.
Vibration, Frequency of Light, 240.
Violle Standard Platinum Lamp, 249.
Volt, Definition of, 45.
Volta, 18.
Voltaic Arc, 16 to 36.
—— Arc, Alleged Discovery of, by Davy, 4.
—— Arc, Bow Shape of, 20.
—— Arc, Carbon, 5.

- Voltaic Arcs, Characteristic Sounds of, 35, 36.
—— Battery, 45.
Volatilization, Constant Temperature of, 27.
—— of Carbon in Voltaic Arc, 27.
Volt-Coulomb, 52, 53.

W

- Wallace All-Night Lamp, 121, 122.
Washer or Ring Clamp, 130.
Water-Motive Force, its Analogy to Electromotive Force, 38, 39.
Watt, 53, 54.
Wire Netting for Arc-Light Globes, 206.
Work, Unit of, 50.
Wright, 8, 124.

UC 622 B
5

University of California, Los Angeles



L 006 178 529 1

UC SOUTHERN REGIONAL LIBRARY FACILITY



A 001 243 214 2

