

BETH-PELET II

PREHISTORIC FARA

BY

EANN MACDONALD

BETH-PELET CEMETERY

BY

**J. L. STARKEY AND
LANKESTER HARDING**

BETH-PELET II

PREHISTORIC FARA

BY

EANN MACDONALD

BETH-PELET CEMETERY

BY

J. L. STARKEY AND
LANKESTER HARDING

LONDON

BRITISH SCHOOL OF ARCHAEOLOGY IN EGYPT
UNIVERSITY COLLEGE, GOWER ST., W.C.1

AND

BERNARD QUARITCH
11 GRAFTON ST., NEW BOND ST., W.1

1932

PRINTED IN GREAT BRITAIN
BY HAZELL, WATSON AND VINEY, LTD.
LONDON AND AYLESBURY

BRITISH SCHOOL OF ARCHAEOLOGY IN EGYPT

PATRONS :

F.M. VISCOUNT ALLENBY, G.C.B., G.C.M.G.
BARON LLOYD OF DOLOBRAN, G.C.S.I., G.C.I.E., P.C., D.S.O.
SIR JOHN CHANCELLOR, G.C.M.G., G.C.V.O., D.S.O.
LT.-GEN. SIR ARTHUR WAUCHOPE, K.C.B., C.M.G., C.I.E., D.S.O.
High Commissioner for Palestine.

GENERAL COMMITTEE (**Executive Members*)

*Prof. B. ASHMOLE	J. G. MILNE
HENRY BALFOUR	Dr. ROBERT MOND
NORMAN H. BAYNES	F. C. MONTAGUE
Prof. R. C. BOSANQUET	*Dr. M. A. MURRAY
*H. DUNSCOMBE COLT	Prof. P. E. NEWBERRY
Mrs. J. W. CROWFOOT	Prof. PINCHES
N. EUMORFOPOULOS	*J. E. QUIBELL
Sir JAMES FRAZER	Dr. RANDALL-MACIVER
*Prof. ERNEST GARDNER (Chairman)	A. L. RECKITT
Prof. PERCY GARDNER	Dr. G. A. REISNER
Rt. Rev. LORD BISHOP OF GLOUCESTER	Capt. E. G. SPENCER CHURCHILL
Mrs. F. LL. GRIFFITH	Mrs. STRONG
Dr. A. C. HADDON	Lady TIRARD
*BASIL HOLMES	The PROVOST OF UNIVERSITY COLLEGE
*E. J. HORNIMAN	Sir HENRY S. WELLCOME
Prof. A. S. HUNT	*Mrs. R. E. M. WHEELER
Mrs. C. H. W. JOHNS	E. TOWRY WHYTE
*Sir CHARLES MARSTON	C. L. WOOLLEY
Sir HENRY MIERS	

Honorary Director—Prof. Sir FLINDERS PETRIE

Honorary Treasurer—*C. H. CORBETT, J.P.

Honorary Secretary—Lady PETRIE

PUBLICATIONS

OF THE EGYPTIAN RESEARCH ACCOUNT AND BRITISH SCHOOL OF ARCHAEOLOGY IN EGYPT

- I. **BALLAS, 1895**; by J. E. QUIBELL. (Out of print; obtainable in joint volume **NAQADA AND BALLAS**, by FLINDERS PETRIE. 68 plates. 20s.)
- II. **THE RAMESSEUM, 1896**; by J. E. QUIBELL. (Out of print.)
- III. **EL KAB, 1897**; by J. E. QUIBELL.
- IV. **HIERAKONPOLIS I, 1898**; text by W. M. F. P. 43 plates. 20s.
- V. **HIERAKONPOLIS II, 1899**; by F. W. GREEN and J. E. QUIBELL. 39 plates (4 coloured and 20 photographic).
- VI. **EL ARABAH, 1900**; by J. GARSTANG. 40 plates. (Out of print.)
- VII. **MAHASNA, 1901**; by J. GARSTANG and KURT SETHE. 43 plates. (Out of print.)
- VIII. **TEMPLE OF THE KINGS, 1902**; by A. ST. GEORGE CAULFEILD. 24 plates. (Out of print.)
- IX. **THE OSIREION, 1903**; by M. A. MURRAY. 37 plates. 25s.
- X. **SAQQARA MASTABAS I, 1904**; by M. A. MURRAY; and **GUROB**, by L. LOAT. 64 plates. 30s.
- XII. **HYKSOS AND ISRAELITE CITIES, 1906**; by FLINDERS PETRIE and J. GARROW DUNCAN. 40 plates. 25s.
In double volume with 94 plates. 45s. (This latter is out of print.)
- XIII. **GIZEH AND RIFEH, 1907**; by FLINDERS PETRIE. 40 plates. 25s. In double volume with 109 plates. 50s.
- XIV. **ATHRIBIS, 1908**; by FLINDERS PETRIE, J. H. WALKER and E. B. KNOBEL. 43 plates. (Out of print.)
- XV. **MEMPHIS I, 1908**; by FLINDERS PETRIE and J. H. WALKER. 54 plates. 25s.
- XVI. **QURNEH, 1909**; by FLINDERS PETRIE and J. H. WALKER. 56 plates. (Out of print.)
- XVII. **THE PALACE OF APRIES (MEMPHIS II), 1909**; by FLINDERS PETRIE and J. H. WALKER. 35 plates. 25s.
- XVIII. **MEYDUM AND MEMPHIS III, 1910**; by FLINDERS PETRIE, E. MACKAY and G. WAINWRIGHT. 47 plates. 25s.
- XIX. **HISTORICAL STUDIES, 1910**; 25 plates. 25s. (Studies, vol. ii.)
- XX. **ROMAN PORTRAITS (MEMPHIS IV), 1911**; by FLINDERS PETRIE. 32 plates. 25s.
- XXI. **THE LABYRINTH AND GERZEH, 1911**; by FLINDERS PETRIE, E. MACKAY and G. WAINWRIGHT. 52 plates. 25s.
- XXII. **PORTFOLIO OF HAWARA PORTRAITS**. 24 coloured plates. 50s.
- XXIII. **TARKHAN I AND MEMPHIS V, 1912**; by FLINDERS PETRIE. 81 plates. 25s.
- XXIV. **HELIOPOLIS I AND KAHR AMMAR, 1912**; by FLINDERS PETRIE. 58 plates. 25s.
- XXV. **RIQEH AND MEMPHIS VI, 1913**; by R. ENGELBACH, HILDA PETRIE, M. A. MURRAY and FLINDERS PETRIE. 62 plates. 25s.
- XXVI. **TARKHAN II, 1913**; by FLINDERS PETRIE. 72 plates. 25s.
- XXVII. **LAHUN I, THE TREASURE, 1914**; by GUY BRUNTON. 23 plates (8 coloured). 63s. Subscription price, 42s.
- XXVIII. **HARAGEH**; by R. ENGELBACH and B. GUNN. 81 plates. 25s.
- XXIX. **SCARABS AND CYLINDERS, 1915**; by FLINDERS PETRIE. 73 plates. 32s.
- XXX. **TOOLS AND WEAPONS, 1916**; by FLINDERS PETRIE. 76 plates. 35s.
- XXXI. **PREHISTORIC EGYPT, 1917**; by FLINDERS PETRIE. 53 plates. 25s.
- XXXII. **CORPUS OF PREHISTORIC POTTERY**; by FLINDERS PETRIE. 58 plates. 25s.
- XXXIII. **LAHUN II, THE PYRAMID, 1920**; by FLINDERS PETRIE, G. BRUNTON and M. A. MURRAY. 75 plates. 25s.
- XXXIV. **SEDMENT I, 1921**; by FLINDERS PETRIE and G. BRUNTON. 47 plates. 25s.
- XXXV. **SEDMENT II, 1921**; by FLINDERS PETRIE and G. BRUNTON. 43 plates. 25s.
- XXXVI. **THE GOSPEL OF ST. JOHN, COPTIC MS.**; by Sir HERBERT THOMPSON. 80 plates. 25s.
- XXXVII. **TOMBS OF THE COURTIERES AND OXYRHYNKHOS**; by FLINDERS PETRIE, ALAN GARDINER, HILDA PETRIE and M. A. MURRAY. 55 plates. 25s.
- XXXVIII. **BUTTONS AND DESIGN SCARABS**; by FLINDERS PETRIE. 30 plates. 25s.
- XXXIX. **ANCIENT WEIGHTS AND MEASURES**; by FLINDERS PETRIE. 54 plates. (Out of print.)
- XL. **GLASS STAMPS AND WEIGHTS**; by FLINDERS PETRIE. 26 plates. Univ. Coll. (Out of print.)
- XLI. **GUROB**; by GUY BRUNTON and R. ENGELBACH. 53 plates. 25s.
- XLII. **OBJECTS OF DAILY USE**; by FLINDERS PETRIE. 62 plates. 50s.
- XLIII. **GERAR**; by FLINDERS PETRIE. 72 plates. 50s.
- XLIV-V. **QAU AND BADARI I and II**; by GUY BRUNTON. 49 and 55 plates. 25s. each.
- XLVI. **BADARIAN CIVILISATION**; by GUY BRUNTON and G. CATON-THOMPSON. 85 plates. 50s.
- XLVII. **BAHREIN AND HEMAMIEH**; by E. MACKAY, L. HARDING, and FLINDERS PETRIE. 29 plates. 25s.
- XLVIII. **BETH-PELET I**; by FLINDERS PETRIE and O. TUFNELL. 71 plates. 50s.
- XLIX. **CORPUS OF PALESTINIAN POTTERY**. J. GARROW DUNCAN. 84 plates. 30s.
- L. **QAU AND BADARI III**; by GUY BRUNTON. 57 plates. 50s.
- LI. **ANTAEPOLIS (QAU)**; by FLINDERS PETRIE. 28 plates. 25s.
- LII. **BETH-PELET II**; by EANN MACDONALD, J. L. STARKEY and L. HARDING. 92 plates. 50s.
- LIII. **ANCIENT GAZA I**; by FLINDERS PETRIE. 62 plates. 50s.

Subscriptions of One Guinea for the Annual Single Volumes, or Two Guineas for the Two Annual Volumes, are received by the Hon. Secretary, at the Edwards Library, University College, Gower Street, London, W.C.1, where also copies of the above works can be obtained.

CONTENTS

PREHISTORIC FARA

By EANN MACDONALD

CHAPTER I

CONDITION OF THE SITES

SECT.	PAGE
1. Relation to the Wady Ghazzeah	I
2. Survey and designation of the Sites	I

CHAPTER II

STRATIFICATION OF SITES

3. Site D	I
4. Site E	2
5. Site O	2
6. Site M	2
7. Site B	3
8. Site A	3
9. Site H	4
10. Sites K, F, L, and P	4

CHAPTER III

ARCHAEOLOGICAL EVIDENCE

11. Site D1, lower levels	4
12. Site D2, upper levels	5
13. Site E	6
14. Site O	7
15. Site M	8
16. Site B, pits	9
17. Site B, settlement	9
18. Site A	10
19. The Burials	11
20. Site H	11

CHAPTER IV

THE COPPER AGE

21. Site H, dwellings	12
22. Site H, pits	14
23. Sites K, F, L, and P	15

CHAPTER V

NOTES BY FLINDERS PETRIE

24. Period relative to Egypt	15
--	----

CHAPTER VI

REGISTER OF OBJECTS	16
-------------------------------	----

BETH-PELET CEMETERY

By J. L. STARKEY AND LANKESTER HARDING

CHAPTER VII

THE HYKSOS CEMETERY

SECT.	PAGE
1. General results	22
2. Principal objects	22

CHAPTER VIII

THE CEMETERY OF XIX-XXTH DYNASTIES

3. Clearance of Hyksos fosse	22
4. Shafts of tombs	22
5. Plates xlvi, xlviii	23
6. Plates xlix, l	23
7. Plates li, lii, liii	24
8. Plates liv, lv	25
9. Plates lvi, lvii	26
10. Pottery of the cemetery	26
11. Foreign pottery	27

CHAPTER IX

THE TELL. NORTH END

12. Clearing of Residency	27
13. Lowest building levels	27
14. Bedroom, bath, and wine store	28
15. Pottery of Philistine type	29
16. Late Philistine period	29
17. Aramaic ostrakon	29
18. Photographs of buildings	29
19. Scarabs (pl. lxxiii)	30

CHAPTER X

DATING

20. Hyksos levels	30
21. Date of Residency	30
22. Date of cemeteries	30
23. Building and destruction	31
24. Date of Philistine pottery	31
25. Lists of Abbreviations and Distribution	32

INDEX	33
-----------------	----

LIST OF PLATES

	PAGE
I. Sketch Map of Sites near Tell Fara	I
II. Fara. Site D. Hasanieh	I
III. Fara. Sites D ₁ and D ₂	I, 2
IV. Fara. Site E. Ibrahimieh	2
V. Fara. Sites O, E and M	2
VI. Fara. Site O. Hadrusieh	7
VII. Fara. Site B. Sultanieh	4, 9
VIII. Fara. Site A. Sulmanieh.	10, 11
IX. Fara. Site H. Shellal Bridge	4, 12, 13, 14
X. Fara. Site H, Dwellings 1 and 2	4, 12
XI. Fara. Sections of Sites E, O, M, B, A, H	2, 3, 4, 8, 13, 14
XII. Fara. Flint Hoes, Sites D, E, O, M	4, 5, 6, 7, 8, 11
XIII. Fara. Flint Hoes, Sites M, B, A	9, 10
XIV. Fara. Hoes, Site A. Scrapers and Picks, Site H	10, 11
XV. Fara. Scrapers. Sites D ₁ , E, O, D ₂ , M	5, 6, 8
XVI. Fara. Scrapers. Sites B and A	9, 10, 16
XVII. Fara. Points and Arrowheads. Sites D, E, O, M, B, A	5, 9, 12
XVIII. Fara. Sickle Flints, Cores, Scrapers, all Sites	7, 8, 11
XIX. Fara. Selected Types of Flints	4, 5, 6, 8, 9, 10, 11
XX. Fara. Selected Types of Flints	5, 6, 9, 10, 11, 12, 13
XXI. Fara. Objects of Site D and Site O	5, 6, 7, 8
XXII. Fara. 4:3 Borers. Site M. Microliths, Site A.	3, 5, 7, 8, 10, 12
XXIII. Fara. Objects Site A. Site H, House I, 7-8 ft.	6, 10, 11, 12, 13, 14
XXIV. Fara. Flints, Site H, 0-4 ft.; also 4-5 ft.	12
XXV. Fara. Objects Site H, 5-6 ft.; also 6-7 ft.	11, 12
XXVI. Fara. Site H, Objects 6-7 ft.; View of House I	13, 14
XXVII. Fara. Special Objects	5, 6, 7, 10, 11, 16
XXVIII. Fara. Special Objects	5, 6, 7, 8, 10, 11, 12, 14
XXIX. Fara. Handled Cups. Sites E, O, M, B, A	7, 8, 10
XXX. Fara. Handles, Sites D, E, O	5
XXXI. Fara. Handles, Sites M, B, A, H.	8, 9, 10, 12
XXXII. Fara. Decorated Pottery. Sites D, E, O, M	6, 7, 8
XXXIII. Fara. Decorated Pottery. Sites M, B, A, H	8, 9, 10, 12
XXXIV. Fara. Decorated Pottery. Site O	7
XXXV. Fara. Decorated Pottery. Site O	7
XXXVI. Fara. Wavy Handles. Site H, Burnished Sherds	12, 14
XXXVII. Fara. Handles and Sherds, Site H	14

	PAGE
XXXVIII. Fara. Pottery and Stone. Sites D1, D2, E	5, 6, 7
XXXIX. Fara. Pottery. Sites O, M, B	7, 8, 9, 10
XL. Fara. Pottery. Sites A, H	10, 11, 12, 14
XLI. Fara. Register of Beads	10
XLIA. Fara. Register of Levels of Flints and Potteries	
XLII. Beth-pelet. Tomb Groups, Hyksos	22
XLIII. Beth-pelet. Tomb Groups, Hyksos	22
XLIV. Beth-pelet. Tomb Groups, Hyksos	22
XLV. Beth-pelet. Hyksos Tombs	22
XLVI. Beth-pelet. Hyksos Fosse. 900 Cemetery	22
XLVII. Beth-pelet. Tombs 905 and 914: XIXth-XXth Dynasty	23
XLVIII. Beth-pelet. XIXth-XXth Dynasty: Groups 905 to 914	23
XLIX. Beth-pelet. XIXth-XXth Dynasty. Groups 915 to 978	23, 24
L. Beth-pelet. Tomb Groups 915 to 978	23
LI. Beth-pelet. XIXth-XXth Dynasty: Group 934	24
LII. Beth-pelet. Tomb Group 934	24
LIII. Beth-pelet. Group 934 (<i>contd.</i>) and 935	24, 25
LIV. Beth-pelet. XIXth-XXth Dynasty: Groups 936 and 960	25
LV. Beth-pelet. Tomb of Groups 936 and 960	24, 25
LVI. Beth-pelet. XIXth-XXth Dynasty: Groups 980-985	26
LVII. Beth-pelet. Groups 980, 981, 982 and 984	26
LVIII. Beth-pelet. Decorated Pottery. Tombs 920, 972, 978	26, 27
LIX. Beth-pelet. XIXth-XXth Dynasty Tombs	23, 24, 25, 26
LX. Beth-pelet. 900 Cemetery: XIXth-XXth Dynasty	27
LXI. Beth-pelet. North End. Jar Seals, etc.	27
LXII. Beth-pelet. North End	28, 29
LXIII. Beth-pelet. Decorated Pottery. XVIIIth-XXth Dynasty	27, 29, 30
LXIV. Beth-pelet. North End. Miscellaneous	28, 29
LXV. Beth-pelet. North End, Hyksos and Philistine Levels	24, 29
LXVI. Beth-pelet. North End. Hyksos and XVIIIth Dynasty Levels	27
LXVII. Beth-pelet. North End. XIXth Dynasty Residency	27, 28
LXVIII. Beth-pelet. XIXth Dynasty Residency: Bedroom, Wine Store	28
LXIX. Beth-pelet. North End. XIXth Dynasty Residency	28
LXX. Beth-pelet. North End. XXth Dynasty Level	29
LXXI. Beth-pelet. North End. Walls of Period of Judges	29
LXXII. Beth-pelet. Additions to Bead Corpus, Sherds from South End of Tell	30
LXXIII. Beth-pelet. South End of Tell: Various	30
LXXIV. Beth-pelet. South End of Tell: Metal and Bone	30
LXXV. Beth-pelet. South End of Tell: Decorated Pottery	27, 30
LXXVI. Beth-pelet. South End	29
LXXVII. Beth-pelet. South End. Hyksos Fort	29
LXXVIII. Beth-pelet. South End. XIXth Dynasty Level	29
LXXIX. Beth-pelet. South End. XXth Dynasty Level	29, 31
LXXX. Beth-pelet. South End. XXIst-XXIInd Dynasty Levels	29
LXXXI. Beth-pelet. South End. Walls of Greek Period	29

	PAGE
LXXXII. Beth-pelet. South End. Roman Levels	29
LXXXIII. Beth-pelet. Types additional to Corpus of Palestinian Pottery	27, 30
LXXXIV. Additions to Corpus	28, 30
LXXXV. Additions to Corpus	30
LXXXVI. Additions to Corpus	30
LXXXVII. Additions to Corpus	27, 30
LXXXVIII. Additions to Corpus and Roman Lamps, 1:3	29, 30
LXXXIX. Beth-pelet. Register of Pottery Types, from City	27
XC. Beth-pelet. Register of 1,000 Cemetery	22
XCI. Beth-pelet. Register of 900 Cemetery	27
XCII. Beth-pelet. Register of 900 Cemetery (<i>contd.</i>)	27
XCIII. Beth-pelet. Register of 900 Cemetery	27
XCIV. Beth-pelet. Register of Beads	32
XCV. Beth-pelet. Register of Beads	32
XCVI. Beth-pelet. Bedawy Tribal Marks on Stones	32

CORRIGENDA

Plates XXV and XXVI. Reverse titles.

Plate XLI. *For* S 46 *read* S 6.

Plate LXXVII. *For* "Fort" *read* "Fortified Gateway."

BETH-PELET II

PREHISTORIC FARA

By EANN MACDONALD

CHAPTER I

CONDITION OF THE SITES

1. *Relation to the Wady Ghazzeah.*—The alluvial deposit washed down from the limestone hills, ranging from the north-east to the south of Beersheba, forms a plain at the outflow from the Beersheba basin. Since its formation, as has been stated in Beth-pelet I, the rains have scoured it into a slightly undulating surface, whilst the flood-water from the hills have cut a channel through to the sea. This torrent bed is known as the Wady Ghazzeah (Gaza); its mouth is five miles south of the modern town (pl. i).

It is evident that the wady existed before the dynasties in Egypt, since the pits and rubbish of pre-dynastic peoples are found centred round the springs. Cattle are still watered at these springs, the chief of which are at Shellal, Ain Fara, Ain Gamleh, Ain Shanag, and Bir Esani. The soft soil of the plain, however, has been denuded at a devastating rate, the present wady at Shellal being over half a mile wide. To examine, therefore, the area affected by denudation seemed the best course to follow.

2. *Survey and Designation of the Sites.*—From time to time in the work at Tell el Fara, settlements had been located by the natives, who, in return for the protection of each particular site, were guaranteed work on it as well as *bakhshish*.

To each newly reported site was given an alphabetical letter, and it was named after the finder, if a neolithic site. This plan of Mr. Starkey's worked very well, reducing the risk of adulterated evidence to a minimum.

During the 1929-30 season, I set out with the

object of examining every site on both sides of the wady from Ain Gamleh to a known site (Alieh) about half-way between Tell el Fara and Tell Jemmeh. A systematic search of the wady and the immediate scarpland was carried out, and each settlement was excavated as we reached it. I had the same ten Arab workmen and their basket-carriers with me throughout the season; so that in a few weeks they became well initiated in the method of excavating and they proved themselves to be conscientious and splendid workers.

On the map the sites do not appear to be concentrated about any particular spring. This is because water happens to be plentiful within the Tell Fara region.

CHAPTER II

STRATIFICATION OF SITES

3. *Stratification of Site D (Hasanieh).*—In describing the stratification of sites, the level of the plain serves as datum for all depths, the variation being so small as to be negligible; the mean height above sea-level is 290 O.D.

The settlement Hasanieh (pl. ii) may have originally been situated in a hollow, but owing to the denudation of the scarpland the evidence has been destroyed. At Um Urgan this scarp is formed by hard loess, sand consolidated by water, deposited on the native marl.

The floor was uneven, varying between 9 ft. and 7 ft. 6 ins. below the surface. Pits of no definite shape had been dug in this floor (pl. iii). A deposit of 2 ft. 6 ins. of irregular seams of ash and charcoal, interbedded with silt, lay above these pits; undoubtedly the residue left by successive tent-

squatters, as pits were found at the 7 ft. 6 in. and the 6 ft. 6 in. levels.

Above this layer was 5 ft. of grey settlement rubbish streaked with darker patches, the remains of hearths. Other hearths were groups of flat stones, blackened by fire, generally oval in shape. They appeared at all levels with the pits. These later pits were also shapeless; there were, however, many intrusive round pits. Here, then, was an upper floor formed by the underlying rubbish of previous squatters and the exposed scarp or high-lying bank of the supposed depression (pl. iii, 2).

This grey-coloured deposit completely filled up the hollow and appeared to have been denuded by the winds, since the apparent bases of several pits appeared just under the surface deposit. The surface layer consisted of 1 ft. 6 ins. of wind-laid sand, and was at plain level.

4. *Stratification of Site E (Ibrahimieh).*—The little that remained of this settlement (pl. iv) was preserved on a tract of the scarpland, separated from the plain by denudation. Deposited on the native marl (11 ft. 4 ins. below the Plain level) was 3 ft. of sandy loess. This was a yellow-coloured deposit, and is not to be confused with the hard water-laid loess, a layer of which, averaging 6 ft. in depth, lay above (pl. xi).

In this firm marl, containing hard concretions of lime, the settlers appear to have cut out their dwellings, very probably from the scarp-edge, though there is no evidence of this. That the existing hut was excavated and not a natural depression there can be little doubt, the walls being almost perpendicular. The sandy loess formed the floor, and doubtless the roof was composed of boughs and skins. Roughly rectangular in shape, the dwelling measured 24 × 17 ft. at its greatest length and breadth and 5 ft. 6 ins. in depth.

A 2 ft. 5 in. layer of sandy rubbish covered the floor of the hut intersected by black charcoal hearth; the proper midden material, however, lay 3 ft. thick above it, and was a more or less homogeneous mass of grey ash and charcoal.

The pits and hearths, located by cross-trenching, were far apart and either round or oval in shape (pl. v, 4). The hearths resembled shallow pits and contained large flat stones and much black ash.

Heavy rains have filled up the hollows in the uneven surface of the hard loess, forming 1 ft. to 1 ft. 10 ins. of loess, similar in texture to the lower band, containing more vegetable matter, however, and no

composites of lime; 1 ft. of wind-blown sand formed the surface deposit.

5. *Stratification of Site O (Hadrusieh).*—Hadrusieh (pl. v, 3) conformed with the lie of the scarpland, which had sunk from the Plain level to a lower level by gradual drainage prior to the date of the settlement. For convenience the high-site deposit was called site O 1, and the low area site O 2 (pl. xi).

The floor of O 1 consisted of 7 ft. 6 ins. of hard loess laid on the native marl, and was very uneven, ranging from 1 ft. 8 ins. to 3 ft. below the Plain level. Pit-heads were found at all levels. From 1 to 4 ft. of settlement material, containing a great deal of sand, lay above the round or oval pits.

Groups of flat hearth-stones lay on the pre-dynastic rubbish below 8 ins. of sand surface deposit; also on the floor of the settlement.

The only pits in O 2 were mere holes in the scarp. Only 1 ft. 2 ins. to 10 ins. of hard loess formed the floor above the native gebel (undisturbed hard marl). Shapeless depressions in this floor, doubtless the sites of tents, were cut through to the native soil, having steep sides and averaging 1 ft. in depth. They were filled with a fine grey ash. 4 ft. of this light-coloured ash, mingled with dark patches of charcoal and dung fuel, was deposited above the level of the dwellings, as we can but call them, the surface deposit being 6 ins.

Site O 2 is therefore either a natural or an artificial hollow sheltered from the winds by the scarpland. Such a favourable position was evidently so congested that pits had to be dug elsewhere, as indeed I found isolated pits in every direction, some being actually dug into the settlement material of site D.

6. *Stratification of Site M (Awadiéh),* section, pl. xi, no plan.—The scarpland at site M contained several convenient hollows in the hard (water-laid) loess, which had been laid on the native marl to an unknown depth. A layer of 1 ft. 9 ins. of sandy loess had been deposited on the normal surface of the hard loess, and presumably on the floor of the hollows. On pl. v, 5, is a photograph of a section of one of these depressions (the second floor) filled with 6 ft. 3 ins. to 7 ft. of stratified grey settlement rubbish. 3 ft. 3 ins. to 5 ft. 7 ins. of disturbed rubbish lay above. Each mark cut in the side represents a 9-in. level. This material consisted of a fine ash interbedded by the black remains of charcoal fires, near the lip of the depression, and by beds of silt, such as can be seen after any rain storm.

The floor containing bead-borers (pl. xxii) was composed of minute fragments of flint, shell, carnelian, green felspar, and quartz crystal.

A glance at this section is sufficient to show that the settlement rubbish was deposited *after* the sandy loess. The fact that this loess does not cover the floor of the hollow supports the idea that the value of a sheltered position was worth the trouble of removing the light sand. On the other hand, if there was no necessity for such a thing, then at least 1 ft. 9 ins. of this bright yellowsand was so thoroughly mixed with ash and rubbish as to avoid detection, which to me seems remarkable. The conformity of the hearths with the slopes of the depression disproves any theory that the loess was deposited after the natural hollow had been filled by the rubbish of pre-dynastic peoples. This is important from a geological point of view. There is little doubt but that the upper levels were disturbed by winds, scooping out here and piling up there. An average depth of 5 ft. of wind-blown sand, forming the surface deposit, suggests that this area was more exposed than most sites.

I located four such rubbish-filled hollows. All pits, however, were dug on the normal surface through the sandy into the hard loess deposits, and some distance away from the actual floors. They were invariably round in shape.

7. *Stratification of Site B (Sultanieh).*—The normal brown matrix in the native marl was not apparent at site B; the gebel here was of an orange-coloured texture, and lay only 1 ft. 3 ins. below the Plain level (pl. xi).

A thin layer of silt (hard loess) had been deposited on the gebel, evidently before the existence of the settlement, which consisted of a congested mass of pits dug through this layer into the native soil. These pits were roughly round and oval in shape, some containing flat stone hearths of no definite shape.

Deposits of silt in the bases of some of the pits denoted further rain storms between the making of the pits and the laying down of sandy loess. Situated just on the edge of the scarpland, the northern area of the settlement was slightly higher than the southern: the winds which laid this loess half filled the southern pits and completely filled the northern pits, actually forming 1 ft. of deposit above them, the deposit on the level ground in the southern area being only 9 ins.

Still more silt was washed down, before 9 ins. to

1 ft. 6 ins. of black settlement rubbish was deposited over some of the exposed pits. The remains of charcoal fires could be traced with difficulty; one round stone hearth, however, was either made or utilised in pit 12, the surrounding loess having been removed.

Many large flat groups of stones, some of them circular (pl. vii), were found on the settlement deposits and high-lying sandy loess. Some, apparently hearths, were smaller and round, made of large flat stones and blackened by charcoal ash. Wind-blown sand, 4 ins. to 1 ft. 1 in. thick, filled in the unevenness of the pre-dynastic surface, though some of the stones were exposed, possibly by recent denudation.

8. *Stratification of Site A (Sulmanieh).*—The floor of this settlement, situated on the scarpland, was 1 ft. 6 ins. below Plain level. It consisted of 2 ins. to 1 ft. 3 ins. of hard water-laid loess deposited on a wind-laid sandy loess (pl. xi).

All the heads of pits and holes were at floor level and were round or oval in shape. 9 ins. of brown-coloured settlement remains, mixed with sand, lay above. Groups of flat stones, sometimes bordered by uprights, lay in this deposit. Others were hearth-stones, distinguished by their blackened surfaces.

The surface deposit was 9 ins. of wind-blown sand.

With regard to the proximity of site B to site A (pl. i), it has been suggested that they formed one large settlement, and that it was divided by recent denudation. This suggestion is based on the strength of archaeological evidence; indeed, there can be no doubt but that they were contemporary or succeeded each other immediately. If the latter case, I should be inclined to place B as the earlier settlement. There seems, however, to be little reason to doubt the existence of the ground being at Plain level during that period.

A glance on the same map, at the area affected round sites E and H, is sufficient on paper to convince anyone that the work of denudation between sites B and A is nothing remarkable. On examining the actual ground however, about A and B, one is bound to admit that it is doubtful whether some 30 ft. of soft sandstone and 20 ft. of hard white limestone, which lie beneath, could be cut through during the same period it takes to denude a larger area of comparatively soft marl, as surrounded site E and site H, the excavation being little more than half the depth of the sand and limestone strata.

Confronted with this, it is not safe to assume that B and A are one, and therefore they must be treated separately.

9. *Stratification of Site H (Shellal Bridge).*—The region of the Shellal spring is subjected to strong south-westerly winds, passing over the El Shauth village, which accounts for the great work of denudation that has occurred.

One or two knolls have withstood the denuding forces, and fortunately site H was one of them.

The native soil proper was many feet below the sandy loess upon which the strata were laid, and does not come into the stratification of the settlement (pl. xi).

A thin band of greenish clay separated the pure sandy loess from 2 ft. to 2 ft. 6 ins. of the impure, which consisted of bright yellow sand streaked with black.

1 ft. of a homogeneous mass of black settlement deposit lay on this floor. A second foot of grey-coloured rubbish material, infiltrated and hardened by water and interbedded by black seams of charcoal, lay above. Yet another foot of brownish settlement rubbish mixed with a great deal of sand and cemented with silt (recent hard loess) lay above that.

Round and oval hearths and groups of small round stones, bordered by flat uprights, lay in this recent deposit.

In passing, it may be noticed that at A (pl. viii) a similar stone construction (other than hearths) occurred just under the surface deposit, and therefore on the ancient surface.

All the open and closed pits in H, however, similar to the hearths in shape, were dug either in the lowest stratum or in the floor of the settlement.

This floor ranged between 7 ft. and 7 ft. 6 ins. below Plain level. The high stack on the right of the photograph on pl. x was left to show the depth of the deposits since removed. The marks are 1 ft. apart. The surface deposit was 4 ft. of wind-blown sand. The top of the stack is at Plain level. The unevenness of the settlement floor is due to natural hollows and depressions. The large dip, however, in which pits 12, 16, 17, 19, and 21 were concentrated (pl. ix) was not taken into account. The bottom of pit 16 may be reckoned as the base of the depression; this was 10 ft. 1 in. below present plain.

Attention is drawn, however, on pl. viii, to the existence of four raised floors or platforms, both round and shapeless, from 4 ins. to 6 ins. high. It

is difficult to say for certain to what use they were put. They may have served the same purpose as the round group of stones overlying site B (pl. vii), but this fails to help us. As a tent flooring they would be hopelessly impracticable, being too small and the wrong shape. One can only surmise, therefore, that they were for some domestic purpose, such as the threshing of cereals or the making of pots.

Hollows for standing pots were much used in the site, although we could not reconstruct any pots conforming the amphora type. The stands in dwelling 1 (there were none in dwelling 2) were all sunken. They were simply conical-shaped holes, scooped in the sand and lined with small sherds. No whole pots were found *in situ*.

This kind of pot-stand was not used outside the hut, but the holes were lined with mud instead of pottery fragments. There was, however, a raised form of clay pot-stand, which consisted of a heap of wet mud hollowed out by hand and allowed to bake in the sun.

10. *Topography of Sites K, F, L, and P.*—These were all surface sites and were situated on the denuded land-surface of the Wady Ghazzeah (pl. i).

Site K (Fatmahmieh) was 20 ft. below Plain level, site F (Derwishieh) 40 ft., site L (Salimieh) 9 ft., and site P (Alieh) 70 ft. These figures are only approximate.

CHAPTER III

ARCHAEOLOGICAL EVIDENCE

II. *Site D (Hasanieh). The Lower Levels: Site D 1, 9 ft. to 3 ft. 7 ins.*

In discussing the material it is proposed to treat the flint forms first, as it is on them that the sequence of sites is mainly based. In photographing the objects, selected examples from consecutive sites are represented in serial groups by their letters, in order that the development of particular forms may be seen, as that of the fan scraper in pls. xv and xvi.

In other plates, groups of miscellaneous objects, from one settlement or stratum only, have been photographed.

The characteristic flint implements of the sites were the hoes, the earliest form of which was found in site D 1. This was of an isosceles triangular shape (pls. xii, 2, and xix, 1), showing very rough workmanship, but in form suggestive of the Le Moustier palaeolithic type.

An improvement was made upon this form in the long isosceles-triangle type (pls. xii, 1, and xix, 2), demanding greater skill. Attempts were made to chip a parallel-sided hoe (pl. xii, 3), but they served only to make a rough barrel-shaped form. In many cases the edges were ground smooth.

Flint "points" conformed to two types, long and triangular (see pl. xvii up to 45, as in B, pl. xx, 29, 30), and were found with a rough form of the tongue-shaped scraper (pl. xv) at all levels.

A long-tanged arrowhead (pls. xvii, 60, and xx, 12) was found in this settlement between 6 ft. 7 ins. and 7 ft.

Sickle flints (pl. xxi, 8) much polished and worn by use, and round flint nodules used as bone-crushers, were found in this and in all other sites.

A great number of long, parallel-flaked cores (pl. xviii), and flakes suggests that flint knapping was done wherever these tent-squatters settled.

Unmistakable signs of a microlithic industry were apparent in the few small cores and flakes that were found. The flakes were never deliberately trimmed, but showed signs of usage.

Pl. xx, 27, 28, shows the method of striking flakes from a nodule of smoky translucent flint, which material was always used for microliths. A plane surface for striking was obtained by detaching a large flake from the nodule with a force directed to the centre. Later, in A, the flakes were struck to produce a conical-shaped core (pl. xx, 27). Precisely the same action was carried out in the knapping of the large, long flakes in A (pl. xx, 37), which were invariably composed of grey flint.

An exceptional form of micro-core is also shown, where parallel flaking suited better.

The Pottery of site D 1 can be divided into two classes which, although they ran side by side in this settlement, can be said to be early and late.

The early class of pots is hand-made and shows no signs of turning, as 2, 3, and 4 in pl. xxxviii. It is distinguished by the coarseness of its fat bow-handles (pl. xxx). The material of which all pots were made was mud or broken-up sherds mixed with chopped straw (*tibn*).

The late type of sherds is far superior in texture, but forms a lesser percentage of the site pottery as a whole. It is wheel-turned and, in comparison with the ugliness of the early type, the handles are well formed (pl. xxx, 6, 7, 8, 9). The pottery was mixed with sand and crushed flint.

Miscellaneous Objects.—A short thick-handled pot-

tery spoon (pl. xxviii, 27) was found in the 6 ft. 7 ins. to 7 ft. level, whereas long-handled spoons (pls. xxviii, 22, and xxii, 2), which were all in higher levels, show that the squat-handles preceded the long form. All spoons were made of mud and *tibn*, baked.

Bone awls (pl. xxi, 9) were found at all levels. Thick vessels of white limestone were used on a large scale. Pl. xxxviii, 1, is the most common form.

Well-made bases, very thick in section, with perpendicular sides were found also. Large flat limestones with carved knobs (pl. xxviii, 25) were peculiar to this settlement. It has been suggested that they were early figurines. As hanging weights they would be practically useless, the incisions not being sufficient to hold a cord: also, in such a case, there is no apparent reason why they should be flat.

Minute toy pots and dishes of mud were common in the lowest levels. Mud dogs (pl. xxi, 10, 11, 12) were made at the same time, growing in popularity as the toy pottery diminished; indeed the two highest levels alone contained seven of these model dogs (pl. xxvii).

Coil basketry was the only plaiting known, this being imprinted, as was the case in every site, on the bases of pots, showing that they sometimes made their pottery on matting.

Whorls of pierced pottery disks, and imperforated disks (gaming pieces?), also rings of hard white limestone (pl. xxviii, 12), probably used in pitching tents, were found in abundance in all sites and will not be referred to again.

12. Site D 2 (*Hasanih*). Upper Levels, 3 ft. 6 ins. to Top.

The flint hoes of this site were all isosceles triangular (pl. xii, 5), with the exception of rough attempts to produce a parallel-sided implement. The most common materials used were flint and breccia, as in site D 1, but no implement of the latter material was found to be ground smooth.

The use of tabular flint was discovered in the making of "fan" or crescent-shaped scrapers (pl. xv). Though rather poor in comparison with those found in subsequent sites, they mark a decided advance in the art of flint-work. The method of working was to produce a broad flat flake, for which tabular flint was ideal, to trim down the bulb of percussion in order to get a sharp, even edge, and dress the flake to the required dimensions.

Pygmy implements (pl. xxi, 3) were found in the upper levels and identified as bead-borers, after the excavation of site M.

Beautiful slender flakes, too long for the cores which were found with them, were worked down one edge and at the tip. The same type of instruments, though of better workmanship, are in A, see pl. xx, 35, 36.

An advance was also made in the sickles, a broad-toothed rectangular variety of flake similar to pl. xx, 38, being produced, all four edges of which were polished with use.

Perhaps a greater number of microlithic cores and flakes were found in site D 2 than in site D 1, yet it appeared to be but a minor industry in the settlement.

An arrowhead (pls. xxi, 1, and xx, 13) low in the strata, with beautiful transverse flaking, was a remarkable find in comparison with the rough long-tanged (pl. xvii, 60) type which was characteristic of the settlements.

With regard to the source from which these and subsequent peoples obtained their tabular flint, I can state with assurance that it was not local, and therefore must have been imported; the nearest known supply is at Misrafa, where it occurs in great slabs a few inches thick.

The black translucent flint employed for microlithic work is also not local, though I have on occasions picked up nodules. The poor-quality flint is, of course, brought down by the Wady Ghazze.

In Palestine there are many qualities of flint. The best is extremely rare, being a translucent mauve-tinted flint, similar to that in the matrix known as breccia. The smoky quality, out of which almost all micro-flakes were made, is much more common. Hoes and "points," however, were made from the worst, but even that was better than breccia, judging from the rough specimens made of that material. Tabular flint falls into a class by itself. It first appeared in site D 2 and, except in rare instances, was used only for fan and oval scrapers.

The Pottery.—The so-called "late" class of pottery in site D 1 develops into the flourishing type peculiar to site D 2. The levels 4 ft. to 3 ft. may be said to be intermediate levels, since both the coarse hand-made pottery of site D 1 and the fine-grained wheel-turned pottery of site D 2 are present. Since they mark no new types, it is safe to say that their

presence is merely the result of the rubbish of one people mixing with that of another.

In the 2 ft. to 1 ft. 7 in. level a great many pots were found in a fragmentary condition, whilst a number of grouped stones and hearths showed a prolonged occupation at the time.

In pl. xxxviii, 6, 7, and 8 are from this level, which produced the best examples of the "late" or site D 2 pottery. Crushed limestone and flint entered into the material of which the large pots were made, and sand was used in making the small dishes.

Miscellaneous Objects.—Wherever there are "fan scrapers," rectangular-shaped fabricators of the type pl. xix, 7, are always found. Although they are made of soft white limestone, these tools are ideal for flaking. There is no reason why they should not have been employed in the making of hoes also.

A polished adze of green basalt (pls. xxviii, 6, and xxvii, 75) was found in pit 7. This is the earliest polished adze here.

Toy dogs of mud (pl. xxi, 2, 4, 5, 6) were still made in site D 2 as in site D 1, but only these four were found.

The early limestone vessels were largely displaced by those of basalt (pl. xxxviii, 9), fragments of fire-stands being found in the stratified settlement rubbish of the type well known later in site A (pl. xxiii, 22, 25).

13. *Site E (Ibrahimieh). Contents of Hut, 8 ft. by 2 ft. 11 ins.*

The hoes of the intrusive peoples (sites E and O) were of the same type as in site D 2, viz. isosceles triangular (pl. xii, 7) in the lower floor, with a tendency to become rectangular in the upper floor (pl. xii, 6). The edges were sometimes ground smooth deliberately or by use.

Tongue-shaped scrapers (pl. xv) were used more by these peoples than by any other settlers. In the site E hut, however, scrapers at low levels were more coarse than those to be found higher up.

A new type of scraper, however, was introduced as an "angular" scraper (type to pl. xix, 8), since on certain flakes only two adjacent sides of the flake were worked, making a sharp angle with one another. Moreover, although this trimming might be termed as "snubbing," as in the case of tongue scrapers, the snub was never prominent.

A small micro-industry was carried on, but the chief occupation appeared to be agriculture, the number of sickle-flints (pl. xx, 32) found being re-

markable; grey flint was largely used for this purpose. Long and triangular "points" were common at all levels.

The Pottery of the lower floor (8 ft. to 5 ft. 11 ins.) did not differ from that of the upper floor (5 ft. 10 ins. to 2 ft. 11 ins.), so the interval between the flooding of the lower floor and the laying down of the upper midden material was of short duration.

For example, the large loop-handled, conical cup, with the handle leading straight up from the base (pl. xxxviii, 10), is found in both floors. A slight variation is shown in the cup from pit 8 (pl. xxxviii, 11), which reappears among the debased forms in sites M and A (pl. xxix, 4, 5). In the same photograph are round-based cups with more pronounced loop-handles placed beside a large form from Egypt for comparison. The presence of thin, fine-grained sherds with painted lattice work, in the hut and surrounding pits, is sufficient for us to say that they are contemporary with the settlement. Crushed flint and mica formed ingredients of the pottery.

Miscellaneous Objects.—Fragments of very rough hard white limestone vessels were common in both floors. On the strength of so little material it is difficult to say whether basalt was unknown at the time the lower levels were deposited, no fragments being found in them; a potter's turn-table (pls. xxviii, 24, and xxii, 21) of that material lay in the upper floor, but no vases.

Pot-bases impressed with plaiting of herring-bone design (xxxv, 11, 12) were found in this settlement.

14. *Site O (Hadrusieh). Area O 1, 3 ft. 8 ins. to Surface. Area O 2, 4 ft. to Surface. Pl. vi.*

As has already been pointed out, the hoes of the E and O peoples remained at the same standard reached by the settlers of site D. Thus in pl. xii, 8, we get the long triangular form of hoe, whilst 9 is the only improvement which has been made upon it—a rough (broken) attempt at parallel sides. Polished edges were few because hoes as a class were not common.

"Angular" scrapers, mentioned in site E, and long delicately worked flakes (pl. xviii, 62) were also found. Their absence in site E can be accounted for by the lack of material in that settlement. Sickie-flints (pl. xxi) were common, the rectangular variety being also used.

Microlithic and large points were common.

It was at first thought that the site D 2 material was later than the intrusion of the E and O settlers,

and in this understanding it was placed after E and O in the serial groups, as will have been noticed. Controversy on the point was ended when it became apparent that such a dating was impossible owing to the presence of rubbish pits, filled with the painted sherds of the O people, dug into the settlement deposits of site D 2.

The Pottery.—In no other site has the pottery been so far advanced as that in site O. Its thin, hard texture has been compared to that of the Solomonic period and contains fine sand, sometimes strengthened with crushed flint.

Deep open bowls (pl. xxxix, 14, 15, 16) were common enough to form a class by themselves. An abundance of painted or colour-washed sherds were collected, but reconstruction was difficult. The small pointed bases (xxxiv) are only found here.

The jar (pl. xxxix, 17) was found in a fragmentary condition round a child's head; but the mouth of the pot is too small to admit a head, so the broken sherds had been placed around the head.

There was no apparent difference between the pottery and flints of areas O 1 and 2. Similarly, there was no difference between the material found in site E from that of site O except that one or two O examples of the round-based cup were painted (pl. xxix, 2) and that the loop-handle is more pronounced in E than it is in site O.

Concerning the order of these two sites there can be little doubt. Taking into consideration that site E was small, it contains, nevertheless, coarser pottery and few of the varied painted and decorated forms which were so abundant in site O; and therefore I should place it as being the earlier of the intrusive invasions.

Miscellaneous Objects.—In both sites E and O, the limestone vases were so coarse as to be merely hollowed stones. Fragmentary firestands and thin open bowls of basalt were found, but stone vessels as a whole were rare and apparently not greatly used. A great many bone awls (pl. xxi) lay at all levels, also an extraordinary number of pottery whorls (pl. xxi), suggesting that these peoples carried on a large textile industry.

Pit 21 produced a toy model of a dog (pl. xxvii, 84), so characteristic of site D, and a lump of quartz and gravel, infiltrated with malachite. Professor Petrie thinks that this mineral may have been used for eye-paint, as in the Egyptian prehistoric.

Evidently the regular herring-bone plaiting (pl. xxxv, 11, 12) was peculiar to the intrusive settlers,

as it is found only on the bases of pots in site E and site O.

Thin plaques of limestone, pierced by two holes near the top (pls. xxi, 15, and xxviii, 11), may have been worn as ornaments or amulets. They appear only in this settlement. Pl. xxviii, 15, is a figurine of white limestone, still showing the marks of the chisel. Little can be said about it except that it was hammer-headed, if indeed this was the head at all. The only pot-mark found was in site O, and is shown in the photograph on pl. xxi, 13.

15. *Site M (Awadih). Section, pl. xi, no Plan. First Floor, 5 ft. to Surface. Second Floor, 14 ft. 9 ins. to Surface. Third Floor, 4 ft. 6 ins. to Surface. Fourth Floor, 4 ft. 8 ins. to Surface. Fifth Floor, 3 ft. 11 ins. to Surface.*

All surfaces were at Plain level and, with the exception of the second floor, the average depth of the surface deposit was 1 ft. 9 ins. It is in the second floor that we get a chronological sequence of types of hoes. The strata between 14 ft. 9 ins. and 11 ft. 9 ins. yield the early isosceles triangular hoe, showing coarse workmanship.

The long triangle type and rough attempts at the parallel-sided type are found at these low levels, but the higher the level, the better the flint-work became. Perfect examples of the rectangular or parallel-sided hoe (pl. xii, 14) and the improved type splayed (pl. xii, 13) are both from the surface. These types have been drawn in detail on pl. xix, 3 and 5.

The fan-scraper form, brought in by the site D 2 people, was perhaps very slightly improved (pl. xv) ; as a whole, however, the work was poor.

The tongue form of scraper (pl. xv, 28) reappears in this settlement, being absent from D 2. Since this type is so usual, because it is the most elementary and therefore the easiest scraping instrument to make, its occurrence can hardly count in the placing of sites in their proper order.

A new use for tabular flint was found in the oval scraper (pl. xv, 31). A flake was struck off, no attempt being made to remove the cortex, and trimmed round the edge. The fracture or bulbar face of the flake was left untouched.

Angular scrapers and long worked flakes, both forms unknown before the advent of the E and O peoples, were used.

The site, however, was characterised by the abundance of its bead-borers (pl. xxii), found in a

floor measuring, over all, 20 ft. × 3 ft. × 3 ft. 2 ins. (pl. xi).

White flint, dull and apparently more durable than the black translucent flint, was used exclusively for the making of these minute artifacts. Bead-borers existed in site D 2, but in very small numbers. That a recognised bead industry thrived in site M is shown by the fact that over a thousand of these bead-boring tools lay on the working floor, among fragments of ostrich shell, carnelian, green felspar, crystal and stone beads.

Among the sickle flints, the broad-toothed variety was found (pl. xviii). This appears to be another flint form derived from the intrusive culture of site O.

The Pottery.—Mere fragments of pottery were left in these rubbish-filled hollows, no. 25 on pl. xxxix being the only form capable of reconstruction. It is doubtful whether 26 is even contemporary with the settlement deposits, since it was picked up on the surface. Both pots, however, were thickly coated with lime, as, indeed, were all sherds, increasing the difficulty of identification and reconstruction. Pl. xxix, 4, is a debased form of loop-handled cup brought in by the E and O peoples. The handle here forms part of the base and is round and small.

The original idea of having the handle so near the base in these cup-forms was to prevent sand getting into the cup when it was hung up after use. This was apparent in the case of 3 in pl. xxix, where the stub of the broken handle has been bored through to enable it to be hooked up or tied with twine.

Miscellaneous Objects.—Two interesting figurines belong to this site. The first, a painted beak-faced specimen (pl. xxviii, 17), was found between 9 ft. 6 ins. and 8 ft. 10 ins. in the second floor. The necklace, painted in below the "eye," is particularly worthy of note.

The second figure (pl. xxviii, 16), though unstratified, can be said to belong to the settlement. Executed in cupreous shale, it is undoubtedly the upper half of a human figure, with the exception of the head. It was made by the slow process of grinding, no incised marks being apparent.

Toy dogs of mud were found in the third and fourth floors, proving another connection with site D. Toy pots were also found in lower strata of the second floor. No such models were made in site D 2 ; therefore it would appear, on the strength of these coarsely made toys and the presence of

isosceles triangular-shaped hoes, that the bottom 3 ft. 9 ins. of the settlement rubbish in the second floor was deposited by a people no more advanced than those of site D 1. Further, scrapers of the fan type do not lie in these strata, but are peculiar to the higher levels.

Basalt did not occur below 11 ft. Above that level were found fragmentary firestands of the site A form, shallow bowls (pl. xxxix, 39), thick, closed bowls (pl. xxxix, 20), and thin, open bowls.

Delicately chiselled bowls of limestone (pl. xxxix 23) were common.

Several lumps of haematite lay in the floors of site M; it is not the first appearance of it in the sites, but the first time much use was made of it.

16. Site B (Sultanieh). The Pits.

From the geological evidence it was proved that the sandy loose-filled pits, cut through a water-laid deposit into the native marl, were of an earlier date than the settlement rubbish deposited above them. This evidence is supported by the material contained in these pits, which, being scanty, may be discussed as a whole.

That the pits belonged to the site D period is established by the roughly made hoes (pl. xiii, 16), which are either isosceles triangular in shape or attempts at the parallel-sided hoe. No perfect example of this latter type was found, and therefore the pits cannot be consigned to the site M people.

Of the pottery little can be said except that from the few sherds available it would appear to have been a coarse early ware, and therefore contemporary with the site D period.

17. Site B (Sultanieh). Level a: Surface Deposit. Level b: Settlement Rubbish.

It was impossible to go down by layers, owing to the complicated stratification of this settlement, consisting only of tent sites, i.e. places wherever the pits were conveniently grouped (pl. vii). It was therefore necessary to remove first the irregular surface deposit and to mark all objects from it as in level a: then to examine the site rubbish beneath, irrespective of tent floors, and regarding all the material from them as being in level b.

Site M produced the perfect rectangular hoe; sites B and A used no other form but this (pl. xiii, 15) except a slight variation. This may be termed the triangular-section hoe (pl. xiii, 17), and is drawn

in detail on pl. xix, 4. Very few of them were found, and they were all larger than the ordinary hoes.

It is in site B that a real improvement was made upon the fan scraper (pl. xvi), of which many raw flakes were found, showing that they were trimmed locally. Others were worn with use, one being highly polished round the working edge, as in the case of sickle flints. The amazing fact about these fan scrapers, which obviously improve in technique throughout the sites, is that no cores were ever found *in situ*, proving that they were bed-struck.

The rectangular fabricators (pl. xix, 7), used for the trimming of these scrapers, were very much more numerous in this site than in sites D 2 and M, though that, of course, may be due to the wholesale manufacturing of hoes as well.

The striking end of the fabricator was rounded, probably to prevent the limestone from splitting, since it was of a soft white nature. This softness prevents stunning the edge in trimming, as the flint bites on the limestone.

Oval scrapers (pl. xix, 10) were common in site B, one specimen being made square-ended.

Lack of material accounts for the omission of such flint forms as the long worked flake, the angular scraper, and even the long-tanged arrowhead, which occur in both earlier and later sites.

Small- and large-toothed sickles (pl. xx, 38) were used in the site. A small "floor," for the making of these sickles, was found on the settlement deposit.

In the early sites little use was made of microliths; in this settlement, however, a definite microlithic industry was carried on. To what use the sharp little flakes were put it is impossible to say. Invariably the edges only were used, both ends of the flake being left untouched.

Some of them, however, were used as bead-borers, very delicate fashioning being necessary beforehand, although white flint, as in all other sites, proved to be the more popular material for such work, as it was tougher.

In earlier sites than B, flint points were either long or triangular in form. Such types, indeed, were just as common in sites B, A, and H, but a variation of the triangular type was also used in these later settlements; this was a long point with a broad end (pl. xvii, 54).

The Pottery.—All pottery was thickly coated with lime and in a very fragmentary condition. It was of the same texture as site D 2, viz. limestone and crushed flint, and sometimes hardened sand. Two

incomplete pot forms were all that could be reconstructed; they are 27 and 29 in pl. xxxix. 29 has been photographed on pl. xxii, and is particularly interesting, the only other example of strainer found being in site O, dwelling 3 (pl. xxviii, 18).

Had a larger area been excavated in site B, such pottery forms as the debased loop-handled cup form (which occurs in both sites M and A) would doubtless have been discovered. As the general material, however, was so markedly similar to that of site A, and because several other sites had still to be examined, time did not allow me to investigate further.

Miscellaneous Objects.—Fragments of basalt, denoting the deep closed form of bowl (as No. 25 in site A on pl. xl, 38), and the thin open form were more common than in previous sites, though insufficient for the drawing of new forms.

Pl. xxxix, 28, is an example of the flat limestone bowl to be found in this settlement.

Haematite, both in sites B and A, was more or less common, several pieces being found worn smooth with rubbing.

18. Site A (*Sulmanieh*). 1 ft. 6 ins. to Surface.

Site A differs from all other sites except B, in that it was a factory for the making of hoes (pls. xiii and xiv) and for scrapers (pl. xvi). The rectangular and the triangular-section hoes (pl. xiv, 25) were the only types known, the early forms, as in site B, having died out.

The majority of the implements were found in neatly stacked piles, twenty-six being the greatest number in any single dump. In that particular dump all the implements were definitely finished (though such was not always the case) and found to conform to two distinct types—rough and smooth—possibly for commercial reasons. So coarse is the work on the former, that it would have been impossible to convert it into a finely finished implement without making it very small. A new variety of hoe was introduced in the broad flat form (pl. xiv, 21, 22), six such specimens being found together in one instance. No polished examples of either this or of the triangular-section type were found. Indeed, hoes with deliberately ground edges formed but a small percentage at any time, though in some of the sites many were polished with use.

Fan scrapers (pl. xvi) were similarly packed away close to one another. The art of producing a large broad flake had at last been mastered (pl. xix, 6); the dressing was a comparatively simple matter, for

we find just as good examples in site D 2. Neither was there any improvement in the oval and angular forms of scraper.

That the standard of flint work, however, was very high in this settlement is shown by the production of long slender flakes (pls. xxii, 18, 19, and xx, 35, 36), which were trimmed sometimes down one edge, sometimes square-tipped or both. We know this type to have been first found in site D 2, but it was not of such fine workmanship. A remarkable fact is that in every site where the long flake implement is known, viz., in sites E, O, M, and A, no cores larger than the sickle-flint cores were found. The inference might be that they were brought in, but obvious signs of manufacture in A disprove this.

Bead-borers were not as common as would be expected in a site with such a great variety of beads (pl. xli), although some of the beads were doubtless imported.

One of the largest industries of the settlement was the manufacturing of microliths (pl. xxii). In all previous sites, again with the exception of B, very few had been made; but in A some hundreds of cores were found, sometimes stuffed into a broken pot. The flakes were worn down and thrown away in thousands. A few of the "points" were made of this translucent flint, but were rare.

The Pottery.—Many examples of the debased cup form were found in this settlement (pl. xxix, 5) as well as new pottery forms (pl. xxiii, 23, 24). Open dishes (pl. xl, 37) were sometimes made with hardened sand, but otherwise crushed flint and limestone pebbles were used in the making of pots, as in site D 2.

With exception of the intrusive sites, there appears to be little, if any, sequence of forms running between D, M, B, and A. Incidentally, in spite of the undeniable influence that the E and O intrusion had upon subsequent settlers, they never attempted to paint their pottery, although there were signs in site A to show that they, at least, had the knowledge and the facilities for doing so.

Here, as in D, M, and B, all sherds were thickly coated with a deposit of lime.

Miscellaneous Objects.—The fabricators of limestone, mentioned in site B in connection with the fan scrapers, were very common. A syenite conoid axe (pls. xxvii, 76, and xxviii, 5) lay in the third floor (pl. viii), and maceheads in hard white (pls. xxiii, 29, and xxviii, 9) and blue limestone (pl. xxvii, 81) lay between 1 ft. 6 ins. and 9 ins.

A palette (pls. xxiii, 28, and xxviii, 7) of chlorite schist, or cupreous shale, lay in the same stratum.

A fragmentary figurine (pl. xxviii, 20) of pink limestone lay in pit 9.

Two mud models of dogs came from the site, one from the surface (pl. xxvii, 83), and the other from pit 18; both were broken.

Basalt and trachyte ware (pl. xxiii, 22, 25) were greatly used in the making of firestands; also for open and closed (pl. xl, 38) bowls.

The number of firestands was remarkable, and three varieties of the same form were noted. In pl. xl, 30 was of trachyte, with a broad band in the middle which was reduced in pl. xl, 34, and finally (pl. xl, 36) it disappeared altogether. The last two stands were of basalt; the first two were among other rubbish thrown into disused grain-pits, whilst the band-less firestand lay in the third floor *above* a pit.

Limestone vessels continued to be in use, though not very common. Bone points, of which there were so few in some of the sites, were very numerous in site A, and indicated basket making.

19. *The Burials.*

Two bodies were found 6 ins. above the settlement floor, and were in a good state of preservation (pl. viii).

There were no traces of any graves, and the only suggestion that they had been given a formal burial was that they were close together; the knees in both cases were drawn up under them and the heads lay roughly to the north. No pots or sherds were found with them, neither were there any flint implements or flakes.

In this site, though in no other settlement, were small piles of animal bones and teeth. These were identified as belonging to pigs, goats, sheep, and dogs.

20. *Site H (Shellal Bridge). 7 ft. 6 ins. to Surface.*

The coming of the H tribe was an actual invasion. The intrusion of the E and O people had apparently been peaceful, since the site M settlers were benefited by it and quite possibly occupied the east side of the Wady Ghazzeah whilst the O tribe camped on the west (for we find no break in the sequence of flint types in the stratified material of site M). Professor Petrie suggests that the H tribe drove the A people into Trans-Jordan, from where they appeared thousands of years later with the Israelites, making their identical forms of hoes at 1100 B.C.

The success of the invaders was due to their knowledge of metal. That it was common with them is shown by the fact that there was a total absence of flint hoes in site H.

This, and the lack of fan scrapers, proves also beyond doubt that the settlers of sites A and H were of different origin, and that the H people, racially distinct from A, had discovered the use of copper ore.

The utter extinction of the flint hoe, on the introduction of copper, leads us to remark upon its form at the time of its disappearance. The earliest examples of metal tools in Egypt took this parallel-sided form; the splay form, too, found its origin among the blunted flint instruments of these pre-dynastic peoples (pl. xii, 13).

Tabular flint, however, was known to them, for we find that they had an abundance of oval and round scrapers (pls. xiv and xix, 10) and a long, pointed variation of the form (pl. xviii, 62). Tongue scrapers (pl. xix, 9) reappeared in the site and, with them, the angular form of scraper (pl. xix, 8) was apparently much used.

With the exception of sickle flints, points, hammer-stones, and such-like implements which were common to all settlements, further flint work in site H was much in advance of any kind yet known; before passing on, a few words should be said in connection with the sickles.

In nearly every case, the teeth of these little saws were broken and worn down with use, the saw-edge being highly polished by friction with the grain stalks. The type drawn on pl. xx, 32, is the only form employed in all sites (pl. xviii) with the exception of H, where a double-toothed variety (pls. xx, 33, and xxv, 59) is found. The flakes from which this form is made are all longer and broader than the ordinary type.

In the same site we get the broad-toothed, rectangular form (pl. xviii, 64), which is generally serrated along one edge only, but a high polish on all four shows that each edge must have been used successively—quite possibly it was not set in a sickle, but was used by hand. The fact that no cores sufficiently large to form flakes 9 ins. in length were found in this settlement, and that there was a total absence of the conical cores of grey flint (pl. xviii) used for sickles, is evidence that the manufacturing of these artifacts was not carried out on the site.

A hitherto entirely unrepresented knife form (pls.

xxiii, 30, and xx, 16) was brought in by the dwellers of site H. Only a few perfect specimens were found, but numerous fragments showed that it was exceedingly common with them. Reference to this form has been made in *Naqada and Ballas*, p. 57.

In pit 10, part of a fish-tailed knife, with ripple flaking, was found (pl. xxii, 16).

In the same pit was a new form of arrowhead (pls. xx, 17, and xvii, 56) denoting the same method of flaking. The long-tang arrowhead (pl. xvii, 57), so scarce in all previous sites, was comparatively common in H. Except for slight variations, this form was that used universally for a considerable period, reaching as far back as the earliest sites (pls. xx, 12, 14, and xvii, 60, 61).

The Metal Work.—Owing to the state of denudation to which the site had been reduced (pl. ix), it was indeed remarkable that so much material was preserved. Fragments of copper pins and sheet were all that lay on the surrounding slopes, although many hundreds of square yards were systematically scraped with *turyiehs*.

In the stratified settlement remains of two unpierced pins were found (pls. xxviii, 3, and xxv, 56) and a smaller double-pointed variety (pls. xxviii, 2, and xxiv, 47).

The most interesting finds, however, were a copper dagger (pls. xxv, 50, and xxviii, 1), which Professor Petrie is able to connect with Egypt, and a fish-hook (pl. xxviii, 8).

The Pottery.—New forms came in with the intrusive site H people. We meet, for the first time, with burnished ware; a selection of these sherds has been photographed on pl. xxxvi, 2. It formed, however, but a small percentage of the pottery as a whole.

The most distinctive feature of the site was its wavy ledge handles (pl. xxxvi, 1), which were found on both large and small pots (pls. xl, 47, 56).

Many of the small forms have been classified as dishes (pl. xl, 39, 40, 41, 42) drop forms (pl. xl, 44, 45, 46). The clay, of which they are made, is sometimes mixed with sand and crushed flint or limestone, and sometimes with chopped straw.

Miscellaneous Objects.—A few pot-bases, each pierced with a graduated hole, were peculiar to site H. It has been suggested that they were equivalent to the universal hour-glass.

Stone vessels were of basalt and alabaster (pl. xl, 52), none were of limestone. The open bowl is indicated in pl. xl, 65. Basalt was also used

for rings (pl. xxv, 53) and bead-grinders (pl. xxv, 52).

Limestone was used for these small rings, as well as for the large ones (pl. xxiv, 38). The same material was used for grinding, probably weapons, since the groove was sharp (pl. xxv, 55).

Sandstone was employed also for bead-grinders. The circumferences of the ostrich-shell beads, which were manufactured in the site (pls. xxiv, 45, and xxv, 54), were found to conform exactly with the grooves. No bead-borers, however, were found, implying that these people had other means of boring their beads than with flint.

Large quantities of copper ore and haematite (pls. xxiv, 46, and xxv) lay at all levels.

An alabaster palette, among the rubbish thrown into pit 13, proved too fragmentary to give an idea as to its form.

A broken macehead of hard white limestone from the denuded slopes of the site is evidence that there were further connections with Egypt. Unfortunately the only realistically carved human figure found in any settlement was also from the surface (pl. xxviii, 14). Though crude, it is a remarkable piece of work for the time. A possible figurine of ground cupreous shale (pls. xxv, 58, and xxviii, 19) came from the lowest stratum.

Model mud dogs, which can be traced right back to the earliest settlements, are present in this, the most advanced of all the settlements.

In the photograph on pl. xxv, 61, are several saw-like bones. These are the dorsal fins of mud fish and not in any way artificial. No indication as to their use has been found.

Piercers of bone in the same photograph, of which there were a great many in the settlement, were those of animals and not of fish.

CHAPTER IV

THE COPPER AGE

21. Site H. *The Dwellings: Construction.*

The peoples of sites D, O, M, B, and A were essentially desert nomads, moving with their tents from place to place; and there was no indication whatsoever in those sites of mud- or brick-made huts. Indeed, in many cases, the actual floors of the tents could be traced out with the eye.

The inhabitants of site H, however, were not tent dwellers, but built rectangular huts (pl. x).

Their living-huts were made very differently from those for storing grain and fuel, for we find that they had both.

Of the two buildings that were preserved on the knoll, one, known as dwelling 1, was for habitation, and the other, dwelling 2, was for storage. It will be best, therefore, to describe them severally.

Dwelling 1.—This was built of mud bricks and stones. The thickness of its outer walls varied between 3 ft. 1 in. and 3 ft. 6 ins. Their greatest height was 3 ft. 11 ins., but there is evidence that they were very much higher, for 4 ft. of wall collapsed bodily into the hut. The fallen brickwork contained very few stones; boulders were apparently only used for strengthening the foundations and the lower half of the walls, being placed in rows. The foundations themselves were dug 6 ins. into the floor of the site, viz. into the streaked sandy loess deposit.

The position of pit 5 (pl. ix) proves clearly that the walls of dwelling 1 have not been partly destroyed, but that the entrance to the hut is to-day what it was in prehistoric times.

There were two chambers, divided by a wall 4 ft. 6 ins. thick, sufficient space being left to serve as a door to the inner room. That there was an actual door was shown by limestone door-sockets found in the hut.

One intention for building a small structure in front of the entrance was doubtless to protect the outer chamber.

The walls of the screen varied in thickness between 1 ft. and 1 ft. 8 ins. only, and therefore obviously they would have been destroyed long before the main walls of the building.

The interior of the two main chambers was rough (pl. xxvi), little attempt having been made to smooth down the mud walls in which the stones were exposed here and there. No roofing material was found, and since, more than likely, it consisted of thatching, it would have perished long ago.

The entrance faced the east; as already stated, the majority of the sand and rain storms blow from a south-westerly direction. Knowing this, it would appear that they built their huts facing east, in order to be protected from the west.

Dwelling 2.—The store-hut was of mud bricks only, not a trace of any stone being found. Roughly rectangular in shape, the four outside walls were 1 ft. 6 ins. to 1 ft. 10 ins. in width and lay 5 ft. 10 ins. below Plain level. Their height ranged between

6 ins. and 1 ft. 4 ins., so that the foundations were 7 ft. 3 ins. down and on the original settlement floor.

It is inconceivable that on building this fuel store, the foundations were laid on the bare ground. They must have been sunk then at least 6 ins., which would make the dwelling later than the lowest stratum (black ash deposit) of the settlement.

Assuming that they built themselves a roof before they built a barn, we have no reason to suppose that dwelling 1 was not contemporary with the beginning of the site.

Dwelling 2 was divided into five irregular compartments (pl. ix), the division walls, commencing with that nearest D1, being 1 ft. 4 ins., 1 ft. 1 in., 2 ft. 9 ins., and 1 ft. 6 ins. thick respectively. There was a difference of 1 ft. 2 ins. between the height of the highest partition and the lowest. The foundation of every wall was 7 ft. 3 ins. below Plain level.

Stratification.

Dwelling 1.—Rubbish remains, mixed with sand, formed the floor of the dwelling.

To establish the levels of the floors was comparatively easy, since the mouths of the pits and pot-stands conformed either to the 7 ft. 6 ins. or to 6 ft. 6 ins. (pl. xi). The floor of site H varied between 7 ft. and 7 ft. 6 ins., so that there can be little doubt but that the huts were contemporary with the settlement. This was strengthened by the fact that 2 ft. of a more or less homogeneous deposit of fine grey ash covering the floor of dwelling 1 corresponded with the depth of the rubbish remains in the site.

1 ft. 3 ins. of fallen brickwork effectively sealed in the material beneath. Here we are provided with evidence that the stone-work lying between the surface and settlement deposits is later than the occupation of the site H people.

Dwelling 2.—Irregular shaped pits dug through a partition wall, and the remains of charcoal fires and rubbish, showed that the store-house was actually inhabited after a lapse of time. Stratified material, 1 ft. 6 ins. in depth, covered the floor of the hut.

Contents

No mention will be made of the flint forms and pottery as a whole, since they have been already dealt with in the discussion of the archaeological evidence of the site, and are represented in both huts.

Dwelling 1.—In the flint work, two new types are to be found. The first was a hollow-based lance-head (pls. xxiii, 31, and xx, 15), which was found with the knife (pl. xxiii, 30) hidden under the walls. As

has been previously stated, the walls were founded in the impure sandy loess deposit. The black streaks puzzled me as to whether they were the remains of early hearth-fires or not, until I found by testing that it was of a geological nature only, and yielded no archaeological material whatsoever. Clearly, therefore, the lance-head and the knife form were contemporary with the hut remains and were not, as might be thought, of an earlier date.

Also on the floor of the dwelling were three large flint picks (pl. xiv, 27), showing extraordinary rough work. A sectional view (pls. xix, 11) of the smallest shows no technique of the palaeolithic types; from this and the perfectly fresh state of the edges, it is seen that they were not specimens brought in from a local palaeolithic site, but were independent products of the site H people.

The presence of fish-bones and the copper hook (pl. xxviii, 8) are not the only evidence we have of fishing. On pl. xxiii, 33, 34, are two notched mother-of-pearl shells. These have been identified as fish scalers, a similar instrument being used today among the fishermen of Italy. The shells, from which they were made, were not found locally.

Nothing has so far been said with regard to cereals. In every site there were grain pits, with the ancient rat-holes still in evidence, but none of the actual grain was discovered. In pit 4 of dwelling 1, however, was found two or three handfuls of charred wheat, which was lodged in a cranny-hole (see the section on pl. xi) made by childish hands in the bottom of the pit. In fact, the floor of the hut was riddled with such hand-made burrows, sometimes containing polished pebbles. Pl. xxiii, 37, was found in one of them. On the original floor of the hut (7 ft. 6 ins. below Plain level) were pots 9, 10, 11, and 12 (pls. xxvi, 66, 65, 67, 64, and xl, 44, 60, 45, 50).

A second occupation took place after 1 ft. of ash remains covered this floor. Two forms, in fragments, of burnished ware (pl. xl, 69, 71) lay on this second floor. In the same level were nos. 2, 5, and 7 (pls. xxvi, 70, 69, 68, and xl, 51, 59, 46). This occupation, it has been pointed out, corresponds to the light grey ash stratum in the settlement deposits.

Dwelling 2.—Very little material was found, chiefly because there was little settled occupation, and that only in the middle compartment.

Completed fragments were found of a deep burnished bowl (pl. xl, 70) on the floor of this section,

and other smaller pottery forms, both burnished and plain (pl. xl, 43, 57, 58, 64).

In one of the narrower compartments were 2 lb. of grain, burnt to charcoal, which had the appearance of either millet or lentils.

22. Site H. The Pits.

On the strength of the rat-holes, it is permissible to assume that the majority of pits were dug for storing grain, whilst others (for they were not all infested by vermin) were used for rubbish. It is not perhaps even too much to suggest that those dug in the actual tent or hut floors and near at hand served for cereals, whilst outlying and unprotected pits contained rubbish only. This, indeed, on the evidence of the rat-holes appears to be the case.

Such arguments are not applicable to site H, where there was a concentrated granary. In the earliest settlements, pits were merely shapeless holes in the ground. Commencing in site M, however, they were made either round or oval in form, and continued so until the latest times, when a new type of grain-pit was used. There were six such pits in H (pl. ix, pits 12, 15, 18, 19, 20, and 21). Whether they were round or oval was apparently immaterial, but there was a slight difference in their construction.

The sides of each pit were dome shaped (pl. xi), with the result that the mouth was very much smaller than the base of the pit. This shell was made of mud, 2 ft. 5 ins. thick at the top and 6 ins. at the bottom. The floor consisted either of stones only (sealed in by the dome), or of mud and stones; in which latter case the mud was smoothed flat and, to all appearance, there was no break between the bottom and the sides of the pit.

The section of the site shows that some of them lay in a large depression, and that this depression was filled in by disturbed impure sandy loess. The reason for the phenomenal occurrence of this sandy stratum I would suggest to be the result of the settlers having deliberately thrown it into the depression to cover up and protect the grain-pits.

Another remarkable fact is that these domed pits contained absolutely nothing, though there were a few sherds and flints mixed up with the sandy filling.

The ordinary type of pit was used in H for storing grain as well. Both pits 6 and 10 harboured rats, whilst remains of barley were in the former.

23. Sites K, F, L, and P.

It is not proposed to discuss each of these surface sites in detail—indeed, the lack of material would render that impossible—but to take them in order, beginning with the earliest, and connect them with the larger settlements.

Site K.—Coarsely worked round scrapers and a rough hoe tending to the rectangular form would place K in era of the site D 1. A small sickle flint was found among the floor chippings, and there were signs of attempts to produce long flakes.

Site F.—Improvement upon K shown by better formed flakes and a broad-toothed sickle. Facetted and long square-ended flakes would consign the work to about the site D 2 period. A well-made "point" and a few microlithic flakes were picked up.

Site L.—Cores and flake chippings showed poor workmanship, although good tongue scrapers and rectangular sickle flints will not permit L to be placed earlier than site M. Unidentified sherds of red ware were found.

Site P.—A large number of hoes were made on the site. They were rough and of the isosceles triangular and rectangular forms. Long flakes, cores, and oval scrapers (of tabular flint) place P as being later than L, but both are of the site M period.

CHAPTER V

24. Notes by Professor Flinders Petrie.

Beside the full account that Mr. Macdonald has given of his careful work, some supplementary matters may be noted.

The sites began to be found by boys who were bringing in palaeolithic flints from the valley bed in 1929. So soon as a neolithic flake was brought, the collection was stopped by refusing to give anything for neoliths, but giving two days' pay for showing a site; the place was then named after the boy, and he had the working of it in 1930. Thus all random collecting on sites was prevented.

A most important matter is the connection that can be found in various places with the series of pre-dynastic Egypt. In the first place, there is a class of thick, rough, pottery cups, with a large side-handle. These have been found as intrusions in Egypt in two instances. The type varies rather from those in the *Corpus of Palestinian Pottery*, 37a, but is closely like two examples from Egypt: the

best fixed is that found in a settlement dated to before s.d. 40 (*Badarian Civilisation*, p. 53, xlvi, 12, xlvii); the other (*Diospolis*, xix, 70) was only placed with later pottery owing to its handle and rough texture. This year such a form was found low in site E, in O, D 2, M, and B, but it did not appear in D 1 or in A or H: the Egyptian example, of Amratian Age, is given here in pl. xxix, 1, and is most like those of site E. Another distinct connection is by the ledge handles, which abound in the early Copper Age site H (pl. xxxvi), and perhaps begin on a very small scale in A. This type in Egypt is first found at s.d. 40, and continued in much the same form till s.d. 60 (*Egn. Prehist. Corp.*, xxviii, 23), though it was soon modified in a wavy form, and passed through many later stages in Egypt. In *Pal. Corp.*, 30 Q, it is termed neolithic.

In stonework there are two pear-shaped mace heads found in A. Such mace heads are not found in Egypt before s.d. 42, and are most usual in the fifties, lasting on into the dynastic times as a convention (*Diospolis*, 24). The dated examples in University College (*Pre. Eg.*, xxvi, 24, 34, 36) are of s.d. 42 and 52. The globular mace here is found in D 1 and M, only of soft limestone.

The copper dagger is first found in Egypt at s.d. 48 to 54 in the flat form, and without a rivet; the riveted form, with a slight mid-ridge, is of 61 to 62 (*Pre. Eg.*, 25). Both of these are larger than that from H, but as Egypt had a much more organized civilization it may well have had a better supply of Sinai copper.

The connections, then, are:

By handled cup of E before s.d. 40.

By mace head of A s.d. 42 to 52.

By ledge handle of H before s.d. 60.

By copper dagger H s.d. 61 to 62.

The sites E and O which are intrusive in the series between D and M differ largely from the rest. They are marked by lumpy rude scrapers, pointed conical cups, fluted pottery, pricked patterns, crescent punching, painted lattice pattern, rod painting, thin hardware, and mat impressions on the base of the pottery. Some of these characters occur at the Teleilat Ghassul north of the Dead Sea (see *Ancient Egypt*, September 1931), and the introduction of basalt and trachyte from E onwards points to intercourse with the Jordan valley. These people seem to have come as peaceful settlers, as there is no break in the development from D to M sites.

Regarding the great growth of the fan scrapers

(pl. xvi), it is evident that the large perfect flakes must have required a very heavy slow blow, as there is no stunning, and the flint mass must have been immovably fixed. The most likely conditions would be by uncovering a table of flint in the rock, and then charging the edge with a battering-ram, perhaps a log of about half a hundredweight. The edge of the flint was carefully prepared for the blow by chipping it into a dome, about the curve of a finger-tip, wide enough to receive such a blow without crushing. This is the grandest handling of flint that is known.

Pl. xxvii. The little clay figures of dogs extend from D 1 onwards to the end of A. The long continuance shows that they were not a mere fancy, and that some meaning was attached. Now it is in this region that the dog tribe of Caleb is well known, and became merged with Judah, with which it took a leading part in the invasion.

Professor Desch, F.R.S., has kindly examined the cupreous material from site H, associated with malachite and copper tools. Also a sample from

near Beersheba, brought by an Arab. He states the analyses as follows:

	<i>Beth-pelet I.</i>	<i>Beth-pelet II.</i>	<i>Beersheba.</i>
	%	%	%
"Copper	6.2	12.3	34.3
Lead	—	—	—
Iron	about 1.0	tr.	tr.
Tin	—	tr.	tr.
Nickel	faint tr.	faint tr.	—
Silica	90.0	79.0	27.5
Alumina	about 1.0	0.7	5.9

"The last is practically the mineral chrysocolla, though containing more combined water than usual. The other two contain a large excess of silica, and appear to be masses of sand impregnated with chrysocolla. I am having a thin section made of one of them in order to determine how the impregnation has occurred. It would be very interesting to know whether these are original ores or whether they have been formed by the action of percolating waters on either metallic copper or a copper ore. They are very unusual deposits. There is no nickel proportion at all comparable with the Mesopotamian materials that we have been examining."

CHAPTER VI

REGISTER OF LEVELS IN FEET AND INCHES

D 2.			
Top.	Flint leaf point, xvii, 47.	Snubbed at base.
1 ft. 6 ins.	Two hoes, plan 1	Triangular sections.
1 ft. 6 ins.	Basalt bowl, xxxviii, 9, pit 6.		
2 ft.	Mud dog, xxi, 6.		
2 ft.	Conical cup, xxxviii, 8, pit 5	Crushed limestone and flint.
2 ft.	Conical dish, xxxviii, 6, pit 6	Flint chip.
2 ft.	Saucer, xxxviii, 7, pit 7	Hard, sand grains.
2 ft. 6 ins.	Jar, xxxviii, 5, pit 8	Crushed limestone. Broken below handles. Each half used.
2 ft. 8 ins.	Adze, xxvii, 75 ; xxviii, 6, pit 7	Green basalt.
3 ft.	Arrowhead, xvii, 59 ; xx, 13	Ripple flaked flint.
3 ft. 6 ins.	Mud dogs, xxi, 2, 4, 5.		
D 1. Below D 2.			
4 ft.	Pottery spoon, xxii, 2 ; xxviii, 22	Long handle. Mud and tibn.
4 ft.	Limestone ring, xxviii, 12	Many found at all sites.
4 ft.	Mud dogs, xxi, 10	Seven recorded.
4 ft.	Flat bowl, xxxviii, 2	Mud and tibn. Hand-made.
4 ft. 6 ins.	Pointed scraper, xvii, 46, 48 ; xx, 21	Poor point.
5 ft.	Bone ring, xxi, 7.		
5 ft.	Open bowl, xxxviii, 3	Mud and tibn.
6 ft. 6 ins.	Mud dog, xxi, 11.		
6 ft. 6 ins.	Pointed shovel, xxviii, 26	Plum coloured, inside dish of flint and sand.

6 ft. 6 ins.	Figurine ? xxviii, 25	Gy, limestone. Also one smaller.
7 ft.	Arrowhead, xvii, 60 ; xx, 12.	
7 ft.	Pottery spoon, xxviii, 27	Mud and tibn.
7 ft.	Mud dog, xxi, 12.	
7 ft. 6 ins.	Cooker, xxxviii, 4	Mud and tibn, see figure.
8 ft.	Flint piercer, xvii, 45	Another of tabular flint.
9 ft.	Figurine ? like xxviii, 25, but smaller, pit 26.	
9 ft.	Limestone bowl, xxxviii, 1	Stain red ochre inside.

E Hut. *Intrusive folk. Painted pottery, basalt, potter's wheel.*

2 ft. 10 ins.	End scraper, xx, 22	Grey flint.
2 ft. 10 ins.	Vase, xxxviii, 13	Crushed flint and limestone.
2 ft. 10 ins.	Decorated sherds, xxii	Red lattice paint.
5 ft. 10 ins.	Basalt wheel, xxii, 21 ; xxviii, 24	Turntable for pottery.
5 ft. 10 ins.	Conic vase, xxxviii, 10	Loop-handle base. Pink wash.
8 ft. 4 ins.	Serpent's head, xxviii, 21	Red pots, crushed flint.
Pit 2.	Conic bowl, xxxviii, 12	Hard sandy ware.
Pit 8.	Sickle flints, xx, 32	Grey flint.
Pit 8.	Conic vase, xxxviii, 11	Loop bands ; flint and lime crushed.

O 1. More pottery forms than E.

8 ins.	Stone rings, xxi	Soft limestone.
1 ft. 8 ins.	Conic bowl, xxxix, 15	Hard sandy ware.
1 ft. 8 ins.	Conic bowl, xxxix, 14	Tibn and limestone, pit 12.
1 ft. 8 ins.	Minute vase, xxxix, 20	Pink wash, pit 18.
1 ft. 8 ins.	Painted vase, xxxix, 19	Plum colour, tibn and limestone, pit 20.
1 ft. 8 ins.	Mud dog, xxvii, 84	Pit 21.
1 ft. 8 ins.	Tall jar, xxxix, 17	Hole mouth. Round child's head, vi.
1 ft. 8 ins.	Oval plaques, xxi, 15 ; xxviii, 11	Limestone, ground, pit 29.
2 ft. 8 ins.	Mud dog.	
2 ft. 8 ins.	Conic plate, xxxix, 21	Hard sandy.

O 2. Stratified midden.

Top.	Figurine ? xxviii, 15	Soft white limestone.
6 ins.	Conic bowl, xxxix, 16	Hard sandy, buff wash.
1 ft. 6 ins.	Gaming piece, xxi, 14	Many unpierced, pottery.
2 ft. 6 ins.	Flint piercer, xvii, 49 ; xx, 18.	
3 ft.	Bone awls, xxi	Basket tools, very common.
4 ft.	Pottery strainer, xxviii, 18	Spout, pit 3.

M 2. Down to 14 ft. 9 ins.

Top.	Figurine, xxvii, 51 ; xxviii, 16	Cupreous shale.
Top.	Long slip, xxviii, 23	Sharp edge, cupreous shale.
Top.	Arrowhead, xvii, 61 ; xx, 14	Flint.
Top.	Cylinder vase, xxxix, 26	Crushed flint and limestone.
Top.	Deep bowl, xxxix, 22	Basalt.
7 ft. 3 ins.	Keeled scraper, xx, 24	Thick flake trimmed.
7 ft. 3 ins.	Trimmer, as xix, 7	Limestone.
7 ft. 3 ins.	Scraper, xv, 31	Cortex on face.
7 ft. 6 ins.	Bead-borers, xxii, 1	In depths of 3 ft. 2 ins. with beads.
8 ft. 9 ins.	Limestone cup, xxxix, 23	Incised on sides.

8 ft. 9 ins.	Hand-axe, xii, 11	Breccia.
9 ft. 6 ins.	Figurine ? xxviii, 17	Red with plum colour. Had eyes, necklace, and dress.
9 ft. 6 ins.	Pointed scraper, xvii, 50	Flint.
10 ft. 3 ins.	Mud vase toys	Common, also below.
10 ft. 3 ins.	Deep scraper, xv, 29 (see xx, 24)	Tabular flint.
10 ft. 3 ins.	Paw scraper, xv, 30	Chert, snubbed end.
10 ft. 3 ins.	Saucer, xxxix, 24	Basalt.
M 3	Vase, xxxix, 24	Sandy pottery.

B. Similar to site A.

Level

A	Sickle flint, xx, 38.	All edges serrated, one polished.
A	Strainer, xxii, xxxix, 29	Flints in pottery.
A	Dish, xxxix, 28	Soft white limestone.
A	Hoes, pair, xix, 4 ; xiii, 17	Triangular section, plan 1.
A	Dump of hoes, plan 3	Three side by side.
B	Jar, decorated, xxxix, 27, plan 2	Limestone.
B	Tabular flint group, plan 4	Working floor.
B	Hoe, thin, wide, xiii, 15, plan 5.	
B	Hoe, polished, xiii, 18, plan 6	Broken, see section xi.
B	Fan scraper, xvi, 33, plan 7	Trimmed both sides, section xi.
B	Fan scraper, xvi, 34, plan 8.	
B	Point tool, xvii, 54 ; xx, 31.	
B	Scraper, xvi, 32	Tabular, trimmed.

A. 1 ft. 6 ins. deep overall.

9 ins.	Six hoes, xiv, 21, plan 3.	Coarse flaking, unfinished.
and on.	Working floor, xvi, 35, plan 5	Small holes.
	Flat hoe, large, xiv, 22, plan 9	Tabular, see xi.
	Fan scraper, xvi, 42, plan 13	See xi.
	Hoes, plans 14, 15.	
	Palette, xxiii, 28 ; xxviii, 7, plan 16	Chlorite schist or cupreous shale.
	Tabular flints, xvi, 36, 40, 41, plan 19	On floor, with unfinished flints.
	Fan scraper, xvi, 39, plan 20.	
	Hoe, plan 23.	
	Deep bowl, xl, 38, plan 25	Basalt.
	Hoe, plan 27.	
	Bowl, xl, 37, plan 28	Sandy pottery.
	Hoe, xiii, 20, plan 35	Best parallel form.
	Dump of scrapers, xvi, 43, 44, plan 38	Finished, piled together.
	Hoe, rough, xiv, 25, plan 45	Triangular section, a silicate.
	Fan scrapers, xvi, 37, 38, plan 61	Longer type.
	Conoid axe, xxvii, 76 ; xxviii, 5, plan 62	Syenite, in third floor.
	Mace head, xxiii, 29 ; xxvii, 79, plan 65	White limestone.
	Hoe, plan 66	Limestone.
	Mud dog, xxvii, 83.	
1 ft. 6 ins.	Long flakes, xxii, 18, 19 ; xx, 35, 36, plan 1	Squared base, one edge trimmed.
and on.	Fan scraper, xvi, 40, plan 2.	
	Hoe, triangular section, plan 10	Limestone.
	Mace head, xxvii, 78 ; xxviii, 9, plan 11	Hard bl. wt., limestone, fine.

Mace head, xxiii, 26 ; xxvii, 81, plan 31 .	Fine form, see xi.
Tall jar, xxiii, 23 ; xl, 21, plan 12 .	Mica, crushed flint, limestone in it.
Flat hoe, xiii, 19, plan 33 . . .	Large size.
Large hoe, plan 46.	
Hoes, plan 47.	
Pointed tool, xviii, 65 ; xx, 34, plan 49 .	Grey flint.
Deep spouted jar, xl, 35, plan 54 .	Crushed flint and limestone.
Fan scrapers, plans 55, 56, 57 . . .	Together, see xi.
Fabricator, plan 59	Soft limestone.
Bone awl, plan 68	Common.
Fan scrapers, plans 69, 70.	
Jar, xl, 32, plan 71.	
Twenty-six hoes in pile, foot square, plan 72	Finished and rough.
Microlith points, xxii	Few finished, mostly rough.
Leaf-shaped point, xvii, 53 ; xx, 19 .	See xvii, 46, from D.
Square scraper, xx, 26	Tabular.
Hollow scraper, xvii, 52 ; xx, 20.	
Figurine head, xxviii, 20, pit 9 .	Pink limestone.
Firestand, xxiii, 22 ; xl, 30, plan 16 .	Trachyte.
Wide point, xviii, 64 ; xx, 25, plan 16 .	xviii, 63, on surface.
Mud dog, plan 18.	
Firestand, xxiii, 25 ; xl, 34, plan 16 .	Basalt.
Firestand, xl, 36, plan 22	Basalt, above pit.

H. Copper Age, with barren layer of marl capping it.

Top.	Mace head, as xxviii, 9	Half ; exposed by denudation.
Top.	Figurine, xxviii, 14	White limestone.
Top.	Deep pick, xix, 11 ; xiv, 26	Flint.
Top.	Long knife, xx, 16 ; xviii, mid. . . .	Creamy patination.
4 ft.	Oval scrapers, xxiv, 39	Tabular flint.
4 ft.	Round scrapers, xxiv, 40	Tabular flint.
4 ft.	Limestone ring, xxiv, 38	Common at each level.
5 ft.	Copper toggle-pin, xxiv, 47 ; xxviii, 2.	
5 ft.	Double-pointed tool, xxiv, 42 ; xx, 23 .	Cherty, like xx, 24.
5 ft.	Long flake point, xxiv, 41	Half of a knife, retrimmed.
5 ft.	Arrowhead, xxiv, 43	Common. Barbless, as in D 1.
5 ft.	Angular scraper, xix, 8	Common.
5 ft.	Triangular point, xxiv, 44.	
5 ft.	Limestone ring, xxiv, end	Similar to basalt, xxv, 53.
5 ft.	Bone plaque, xxiv, 45	Broken, hole at each end.
5 ft.	Haematite, xxiv, 46	Common, worn lumps.
6 ft.	Copper dagger, xxv, 50 ; xxviii, 1.	
and on.	Splayed points, xxv, 49, 51	Like xvii, 54, in A.
	Broad knife, xxv, 48	Worked like xviii, 30.
	Ring, basalt, xxv, 53	Found at all levels.
	Bead-grinder, xxv, 52	Basalt.
	Beads, ground, xxv, 54	Ostrich egg. Multitudes unfinished.
	Wide bowls, xl, 48, 49	Sand and flint ; tibn and limestone.
	Pot, xl, 55.	
	Globular jar, xl, 62	Grey ware.
	Wide jar, xl, 63	Grey ware.

	Globular vase, xl, 67	Pink. Wavy handle fragments.
7 ft.	Copper fish-hook, xxviii, 8.	
and on.	Hairpins, xxv, 56, xxviii, 3	Copper, tops ornamented ?
	Sickle flint, xviii, 66	Rectangular.
	Palette, alabaster	13 ins. thick, 1 ft. 8 ins. wide.
	Figurine xxv, 58 ; xxviii, 19	Cupreous shale.
	Limestone grinder (?), xxv, 55	Angular groove.
	Netting mesh, bone, xxv, 57	Rib bone.
	Engraved ostrich-shell, xxv, 60 ; xxviii, 13	Fragments common.
	Dorsal fins, xxv, 61	Of mud fish, very common in Egypt.
	Conic bowl, xl, 65	Basalt.
	Conic bowls, xl, 40, 42	Sand and crushed flint.
	Vase, burnished, xl, 54	Flint chips and tibn, brown slip.
	Globular vase, xl, 47 ; xxxvi, 1	Pink ware.
	Jar, as xl, 63	Grey ware.
Pit 1.	Bone-crushers	Common in each level.
Pit 5.	Conic saucer, xl, 53	Hard sandy, brown wash.
Pit 6.	Decorated pot, xl, 61	Finger-tip marks ; hard red ware.
Pit 10.	Arrowhead, xvii, 56 ; xx, 17	Fine regular dressing.
Pit 10.	Fish-tail lance, xxii, 16	Very fine ripple work, imported ?
Pit 11.	Small bowl, xl, 50	Hard pink ware.
Pit 13.	Pottery dog amulet	Top missing : pairs of legs undivided.
H 1. Dwelling. Flint and pot types, same inside and outside of walls.		
6 ft.	Double-edge sickle, xxiii, 35	Abundant.
6 ft.	Pottery whorl, xxiii, 36	Biconic. Red.
6 ft.	Conic bowl, xl, 69	Haematite slip, burnished.
6 ft.	Deckle edge, xl, 68.	
6 ft. 6 ins.	Basalt bowl, as xl, 65, plan 1.	
and on.	Pot, xxvi, 70 ; xl, 51, plan 2	Crushed flint ; hard cores.
	Pot base, amphora type, plan 3.	
	Globular jar, as xl, 62, plan 4.	
	Pointed vase, xxvi, 69 ; xl, 59, plan 5	With chopped straw.
	Handled vase, xxvi, 62 ; xl, 71, plan 6	Haematite slip ; burnished vertical.
	Globular vase, xxvi, 68 ; xl, 46, plan 7	Crushed flint and mica.
7 ft. 6 ins.	Basalt base, xl, 66, plan 8.	
and on.	Basalt ring, as xxv, 53.	
	Scraper, round, xxiii, 32.	
	Drop vase, xxvi, 66 ; xl, 44, plan 9	Crushed flint and mica.
	Small pot, xxvi, 65 ; xl, 60, plan 10	Tibn.
	Drop vase, xxvi, 67 ; xl, 45, plan 11	Crushed flint and mica.
	Wide jar, xl, 64, plan 12	Tibn in grey ware.
	Small bowl, xxvi, 64, plan 15	Similar to xl, 50.
	Serrated shells, xxiii, 33, 34	Shells common, see xxv.
8 ft.	Long-flake knife, xxiii, 30	Four perfect, and fragments at all levels.
and on.	Lance head, xx, 15 ; xxiii, 31.	
	Heavy pick, xiv, 27	Two in floor, see side xix, 11.
	Plaque, pierced, xxiii, 37	Cupreous shale. In hole of floor.
	Alabaster cup, xl, 52	Four handles.
	Bead-grinder	Sandstone.
	Conic bowls, xl, 39, 41	Crushed flint and sand.

H 2.	Dwelling, same age as H 1.				
6 ft. 6 ins.	Wide jar, as xl, 64	.	.	.	Grey ware.
6 ft. 6 ins.	Millet, possibly lentils	.	.	.	Burnt to charcoal.
7 ft.	Deep bowl, xl, 70	.	.	.	Haematite slip, burnished.
7 ft.	Handled barrel vase, xl, 58	.	.	.	Brown slip, burnished.
7 ft. 6 ins.	Spheric bowl, xl, 43.				
7 ft. 6 ins.	Necked vase, xl, 57.				
7 ft. 6 ins.	Small globular vase	.	.	.	Pink ware, as xl, 56.
8 ft.	Painted sherds	.	.	.	White with ochre stripes.

For INDEX see end of Volume.

BETH-PELET CEMETERY

By J. L. STARKEY AND LANKESTER HARDING

CHAPTER VII

THE HYKSOS CEMETERY

1. A FURTHER twenty-five tombs of the Hyksos period were cleared this season, and produced groups of pottery, scarabs, bronze daggers, and toggle-pins: they were similar in style to those found the previous season (see *Beth-pelet I*), and do not appear to represent any different phase of the period. With them a number of uninscribed amethyst and green jasper scarabs were found, some in bronze ring mounts, pl. xlii.

2. The order in which the groups are arranged is a purely tentative one. From the evidence of the scarabs, tomb 1021 would appear to contain the earliest burials, pl. xliii, nos. 7, 8, and 10 being early in the series, and 16, 21, and 22 at the end. An unusual object from this tomb is the decorated ostrich egg, pl. xlii: the design is thrown into relief by a pitted background. The tomb had been robbed anciently, and with the exception of burials A, B, and C, the bodies could not well be kept in separate groups (see plan, pl. xlv). Next in order is 1011, with a scarab bearing a good spiral design round a cartouche containing hieroglyphs, which do not, however, appear to read as a royal name. This is followed by 1016, with a scarab showing a lion and "Su" sign, a bronze bangle, and finger-ring. 1018 and 1004 appear to come next in the series, 1018 containing a dagger with a laminated handle of ivory, bronze, and a third material, now perished, which may have been wood, pl. xliii, 29, and a large double-faced plaque, 30. This group also contains microlithic flint flakes, 35, similar to those in group 596 (*B.-p. I*, pl. ix), possibly barbs from arrow shafts. The only specimens of alabaster vases yet found at Tell el Fara occur in 1004. Similar types of better quality from Egypt are illustrated in Harageh, pl. xlvi, dated by scarabs to the xiith dynasty. The remaining groups on pl. xlv appear to be very close

to one another in time, and to represent the latter end of this series (*B.-p. I*, pl. x), see Register, pl. xc.

CHAPTER VIII

THE CEMETERY OF THE XIXTH-XXTH DYNASTIES

3. THESE tombs are all cut into the slopes of the Hyksos fosse, mostly in the east side nearest the town: a clearance was made on a large section of the west side of the trench, but produced only a few single burials. We knew, however, from the previous season's work that the eastern side contained large chamber tombs (*B.-p. I*, pl. xiii), so work was continued on that side. The clearance of these tombs involved the removal of soil to a depth of some 20 ft. in the deepest part (see xlvi, 2); as this was mostly wind-laid deposit with little chance of antiquities in it, the men were put on to piece-work. Two men were given an area 3 metres wide by about 8 metres long, and the depth of their clearance was measured at the end of each day's work. Pay was at the rate of 3 cubic metres for a piastre for the top 2 metres, which was light soil, and 2 to 2½ cubic metres for a piastre for the remaining heavier filling, much of which was encumbered with fallen stones from the town buildings. Each man had three large and strong basket-boys—in some cases the "boys" were considerably older and larger than the pick men—and they not infrequently doubled a normal day's wages of six piastres, the boys' pay being increased in proportion to the men's earnings. Thus an area some 21 metres long by 8 metres wide would be cleared to the required depth by fourteen men and their boys in something under a fortnight, a task which, at ordinary rates of pay, would have taken at least a month.

4. The two shafts, pl. xlvi, 1 and 4, sunk on the west side of the fosse and running west to east, were apparently attempts to excavate chambers in that

side which failed to strike the native marl and emerged instead in the rubbish filling the narrow central trench; these attempts were then abandoned. From this we may assume that by this date the existence of the central trench, and indeed the whole meaning of the fosse, had long since been forgotten, and it was already more than half filled.

The plans of these tombs, pl. lix, suggest a type intermediate between the Hyksos and Philistine series, but more closely allied to the latter. Nos. 934 and 935 are, except for the central well, almost Hyksos in plan, while 902 (*B.-p.* I, xiii) is the most nearly Philistine¹ in type.

The groups as arranged in the plates are in numerical order, not in order of date. All scarabs, unless otherwise stated, are of steatite, and a list of contractions and abbreviations used will be found in section 25.

5. Pls. xlvii and xlviii: tomb groups 905 to 914. Group 905 contains eleven scarabs, which from their style, and the presence of forms of pottery reminiscent of thin base-ring ware, would seem to date the group to early nineteenth dynasty. A child's pottery rattle, crudely modelled to imitate a female figure, comes from this tomb, also a limestone spindle whorl, 12. The photograph on xlvii shows the bench on which the bodies were laid out, and the central well where most of the larger pottery and water jars were stacked. The gypsum tazza is of the form usually associated with these tombs; the finely banded Egyptian alabaster is never found in this period. Tombs 909 and 910 were both situated on the west side of the trench. Tomb 914 furnished the largest group of objects in this series: it is fairly closely dated by a scarab of Mer-en-Ptah from burial E (25), and one of Rameses II from burial F (35). The bronze dagger, chain, spear head, bowl, and strainer cannot be attributed to any particular burial, but seem to have belonged to one of the earlier interments which had been pushed to the back of the bench to make room for a later one, as these objects had all been placed together in the south-east corner of the chamber, pl. xlvii. The dagger handle is inlaid with wood, and the blade differs in form from that found the previous season (*B.-p.* I, xxvi); that also had a similar bronze chain attachment, but was in association with Philistine

pottery, which never occurs in the 900 cemetery. The scarab of Mer-en-Ptah was mounted in a silver finger-ring. Gold and silver ear-rings of the usual form, 18, 19, and 36, were found, also a silver toggle-pin, 30, and fragments of a silver headband and silver discs with stamped design, 32, possibly from a head-dress. Bedawy women at the present day wear quantities of pierced coins, and sometimes metal discs and plaques, as decoration on their head-dresses. Paste amulets of Ptah-Seker-Osiris, 33, and Bes, also occur in this group, pl. xlix. The photograph on pl. xlvii shows the large stone which blocked the doorway of the tomb; this method of sealing is usual in all the large chamber tombs.

6. Pls. xlix and l: tomb 915 contained a drop-shaped pottery vase, 75 N1, a bronze anklet, and the usual paste amulets, similar to group 929. 916 contained a green glazed scarab, showing a very degraded figure of a hippopotamus (?), and a dipper flask, 50 U. 917 has a wish scarab: "May Ptah-nefer-her, Lord of Truth (?), give strength" (*Petrie, Buttons and D.S.*, xxvi). 918 contained pottery, amulets, and an anklet of similar type to 38. 920 has the first example found here of pottery type 37 J, decorated with the gazelle and bird pattern, pl. lviii: also Mykenaeen forms in local ware, pl. xlix. The bronze ring, 41, was on the hallux of the left foot: bronze ear-rings of the usual type (as 92 and 93) also occur, and fragments of a bronze kohl stick, and a small rod of kohl still bearing the impression of its reed tube. The scarabs from this group, 42 to 45, are reminiscent of the late Hyksos style, which is well dated, however, in tomb 962 (97) by a plaque showing a figure of Ra in this style standing before a cartouche of Rameses II. Tomb 921 has a typical scarab of Rameses II, 46, and two others and a plaque of the usual type. 922 has four scarabs showing couchant sphinxes, 52 to 55; the remainder include two bearing the name Men-Kheper-Ra, Thothmes III, 62 and 71, neither of which appear to be contemporary xviiith dynasty work. There is also a pilgrim flask in imported Mykenaeen ware; a gold finger-ring with a carelessly engraved bezel, probably representing Bes; two gold ear-rings, and a quantity of beads of stone and glazed paste, pl. xlix. Tomb 923 contains a lion scarab, and one pot in imitation of a thin base-ring form, pl. xlix. 924 has one pot only, which is, however, of a new form, type 76 C 6. Tomb 925 has silver horn amulets, 56, silver ear-rings, 57, and three scarabs, of which 58 may be intended to

¹ In speaking of Philistine in this volume, the culture represented by the painted pottery (pl. lxxv), which is usually attributed to the Philistines, is to be understood, not the Philistine peoples as such.

read User-Maat-Ra, Rameses II. 926 A has two scarabs, one showing a man and crocodile, very much worn, which might be a Hyksos survival, 65; also a new type of drop-shaped vase, pl. xlix. 926 B has a green glazed scarab, 67, of a type found in tomb 532 (*B.-p.* I, xxii, 204). 927 contains only pottery, while 928 has bronze anklets and ear-rings, 73, and two scarabs, one with the name Men-Kheper-Ra, 74, and the other showing two hawk-headed figures (? Ra) standing one on either side of a pillar. 929 has silver ear-rings similar in form to 92, and paste amulets of Ptah-Seker-Osiris, Bast, etc., pl. xlix. 930 has one scarab only, 51; 931 has two, 77 and 78; 932 and 933 have paste amulets of the usual type. 938 contains only pottery: 939 has three scarabs, 79 to 81, and a Mykenaeen false-neck vase of imported ware, pl. xlix. 940 contains a green glazed plaque similar to 22, but with the name Men-Kheper-Ra on one side, and User-Maat-Ra, Rameses II, on the other: also bronze bangles similar to 73, and the usual paste amulets. 941 has a carnelian uzat, 76, and bronze bangles; 942 contains bronze ear-rings, 92 and 93. These ear-rings, together with nos. 83 and 100, from tombs 946 and 964 respectively, represent the usual types of plain ear-rings found in these tombs, both in bronze, silver, and gold. 949 has three scarabs and a silver ear-ring, all of the usual types, 84 to 87. Tombs 951, 953, 963, 970, and 976 each contain one scarab only, nos. 88, 89, 98, 104, and 106 respectively: the latter is similar to *B.-p.* I, xxii, 203. 955 has a scarab reading Ra-meses, either Rameses I or II; 956 and 961 contain examples of silver ear-rings decorated with granular work, 94 and 99. On pl. xlix are illustrated scarabs from tombs 957, 967, 974, and 978. The latter is an important group, including a jug, pl. xlix, and bowl, pl. lxxv, 18 G 7, both decorated with the gazelle and bird pattern, and dated by a scarab to Rameses II: the style of the other scarabs suggests that the group belongs to the latter half of his reign. Tomb 972, with a scarab which reads Ra-meses (possibly Rameses I), 105, also contains a pot with the gazelle and bird decoration, pl. lviii.

7. Pls. li, lii, and liii: tomb 934. This was the largest tomb of the series (see plan, pl. lix), and one of the only two robbed anciently, the other being 935: in both cases the stone blocking the doorway had been removed, and was lying at the foot of the steps. In 934 practically everything had been cleared off the benches and thrown into the central

well, but in spite of this destruction there remained a considerable number of small gold objects, and 126 scarabs and plaques, in a confused mass with a quantity of very fragmentary human bones. The scarabs include twenty-three bearing royal names, nos. 107 to 129, from Se-kha-en-Ra, of the xvth dynasty, to Rameses IV: the first is undoubtedly a survival, and probably the earliest date that should be assigned to the first burials in the tomb is the very end of the xviiith or beginning of the xixth dynasty. Among the scarabs of Thothmes III, nos. 109 and 111 may be contemporary xviiith dynasty work, while the remainder would seem to be later issues. 108 shows an unusual subject, with two apes adoring the obelisk, and a kneeling Nile figure worshipping the name of Thothmes III. The scarabs of Amenhetep III are of poor quality: 116 may be contemporary work, but 114 and 115 are clearly later issues. 117 is of Sety I (Men-Maat-Ra-Heq); 118 to 125 are of Rameses II; 126 to 128 Rameses III, and 129 Rameses IV (Heq-Maat-Ra-mer-Amen). 130 may possibly be Sety II (Set-mer-en-Ptah Setep-en-Ra), and 131 might be intended for Tut-anekh-Amen (Neb-Kheperu-Ra). It would thus appear that the tomb must cover some 150 years, from about Rameses I to Rameses IV, a not impossibly long period, in view of the amount of material and number of scarabs. Nos. 133 to 140 are of Rameses II, and show the king riding in his chariot, worshipping the baboon, smiting his enemies, or standing with deities. 141 to 147 show couchant sphinxes with a Maat before them; 148 to 158 and 161 and 168 are probably Hyksos survivals, while nos. 159 to 167 are, with the exception of 161, xixth dynasty. No. 169 shows the lion devouring the head of a Syrian (?) enemy, as in 112: the lion presumably represents the king. Nos. 180, 185, 195, 200, 205, 206, 208, 209, and 211 seem to be among the latest; the jasper plaque, 212, is typical of late xixth dynasty work. The remainder have no distinctive features for close dating, and could come anywhere in the group. There were also twenty-three uninscribed scarabs in amethyst and carnelian. The haematite cylinder seal, 213, shows two male figures wearing conical hats, the left-hand figure having what appear to be horns protruding from his forehead (compare pl. lv, 299). Between them are three crescents and a dog (?), and in the background a table or altar on which are standing three tall conical objects.

The objects in gold, pl. li, include three ear-rings with large drops, of a form not hitherto found here;

an engraved and chased horns amulet ; a headband of light sheet gold with stamped linear design ; three large bi-conal beads of sheet metal with lapped, unsoldered joint ; nine ear-rings of the usual type in varying sizes, and a finger-ring with oval bezel engraved with a fish. In silver there are an engraved finger-ring, a disc with stamped design, 181, probably from a head-dress, and a toggle-pin, 191. There are also five well-polished carnelian and amethystine quartz uzat amulets ; a paste finger-ring, 201 A ; amulets of the usual types and quality, a child's rattle in local red pottery, of dumb-bell form ; and a large series of beads in stone, paste, and bone. Photographs of selected scarabs are given to show the style of workmanship. Fragments of many gypsum vases similar to 182 were found, but these were all badly decayed by dampness, the result of ancient flooding of the tomb before the collapse of the roof, shown by a water-laid deposit filling the lower levels of the chamber.

Pl. liii : tomb 935. This tomb and no. 934 were the largest, and, as mentioned above, were the only ones plundered : the plundering had been done anciently, as in many other sites, probably soon after the tombs had fallen into disuse, and certainly before the collapse of the roof. Among the scarabs is one of Thothmes III, 220, with a title which may read " Lord of the scorpion archers." 221, from the style of work, does not appear to be contemporary xviiith dynasty ; 223 has the name of Thothmes IV, Men-Kheperu-Ra ; 222 and 224 to 227 are of Rameses II : 228 and 229 show couchant sphinxes with Maat in front ; 230 may read " Beloved of Amen and Mut." Nos. 234 to 238 and 243 are early survivals ; the remainder are of contemporary xixth-xxth dynasty types. 247 is the bezel of a red jasper finger-ring. There were fragments of a coarse pottery slipper coffin, similar to those found in tombs 552 and 562 (*B.-p.* I, xxiv), although here no trace of a mask cover was found. Also a plaque of light sheet gold, 239, with punched design, no doubt of similar use to the silver discs in tombs 914 and 934, comes from this tomb, and a fragment of bone inlay, 239 A, no doubt from a small wooden box.

8. Pls. liv and lv. Tomb 936 was one of the smaller chamber tombs without central well, similar in plan to 920 (pl. lix). The photographs show the entrance with the stone sealing in position, and after its removal, exposing the stone jambs and lintel. The earlier burials had been pushed back into the corners of the chamber to make room for the later

ones, and four skulls had been carefully stacked against the wall in the south-east corner.

Scarabs from this tomb bear royal names of Amenhetep II, 250 ; Thothmes III, 251 to 255 ; and Rameses II, 256 and 257. Nos. 250 and 252 are probably the only ones of contemporary xviiith dynasty work, and from the general style of the remainder, the burials appear to range in date from the first half of the xixth to the beginning of the xxth dynasty. No. 257 shows the degradation which scarab design can reach even in this period ; and in the plaque 277 the hieroglyphs are mere blundered copies, although the figures of the deity and king on the reverse are fairly accurately made. Nos. 285 and 287 are Hyksos survivals, and the scaraboid 290 appears to be xviiith dynasty work. Figs. 266 and 267 should be inverted, being blunt arrow heads, as shown by examples in the tomb of Tut-ankh-Amen. There is also a bronze toggle-pin with plain head, 275. The gypsum vase, 276, has on its side an incised decoration of chevrons, the lines being filled with black, and is not ribbed, as is usually the case with these tazzas : four others, of the usual ribbed form, badly decayed, were also found. In addition, there were some circular, flat cakes of bread (?), 2 to 2½ ins. in diameter, originally contained in a coiled basket, of which only fragments remained.

960 was the only tomb of the chamber type which was found both unrobbed and structurally intact, neither roof, supporting pillar, nor walls having collapsed ; and the marks of the tools used by the ancient workmen in the original excavation of the chamber were plainly visible on the surface of both roof and walls. The burials were lettered A to K, and the associated objects kept in their groups, except for some beads and five scarabs, nos. 321 to 325, which were not found in clearing the benches, but were subsequently recovered in the course of sifting. A fine scarab showing Rameses II, driving his chariot over defeated Syrians, dates burial A (293 A) : 295, also of Rameses II, dates burial B. 297 from burial C is of Rameses IV ; 298 cannot be intended for a royal name, as only two kings with the name Neb-ka-Ra are known, one of the iiiird and the other of the xvth dynasty, and the workmanship would not warrant either date. 299 has a figure of a Syrian winged deity, wearing a cap with horns and a streamer (*Resheph* or *Setekh*), in association with a hippopotamus above and a hawk bearing a flail in front. This burial cannot, then, be

earlier than Rameses IV. Body D has two scarabs with the name of Thothmes III, 308 and 309, but neither appears to be of contemporary work, and by their style the remainder would suggest the early nineteenth dynasty. Its position in the tomb, having been pushed back into the north-west corner, confirms that this must be one of the earliest burials, removed to make room for later ones. The scarabs from burial F, 314 to 316, place it late in the series, with the exception of 315, which seems to be an early survival: nos. 318 and 319 from bodies J and H respectively would date them to the twentieth dynasty. Looking at the plan, pl. lix, one would presume that bodies A and B were placed in the tomb after body C, that is, after Rameses IV. Bodies G and H were put in after J and K, as they overlaid them, and presumably before E and F. Therefore the earliest date to which the burials can be assigned is the early nineteenth dynasty, and the latest is the middle twentieth dynasty. The bronze bowl could have belonged to either B or C, as it lay between them; the socketed bronze spear-head cannot with certainty be attributed to any particular burial, but in all probability belonged to D, like the rattle, pl. liv.

9. Pls. lvi and lvii: groups 980 to 985. 980 contains two scarabs with the name of Thothmes III, 327 and 328, neither of which appears to be contemporary XVIIIth dynasty work; no. 327 was mounted in a bronze finger-ring, similar in shape to pl. xlvi, 31. Three others, 329 to 331, are of types which are usually late. No. 329 has a fish back; this motif in relief on the backs of small steatite scarabs is characteristic of the ninth–twentieth dynasty (see nos. 77, 123, 240, and 281). Also from this tomb is a calcite duck spoon, 326, with a painted decoration in black (the duck's head is, however, missing), and a number of paste amulets and beads of types common to these tombs.

Group 981 has two scarabs of Thothmes III, 332 and 333; one of Neb-Maat-Ra (Amenhotep III), 334; one of Rameses II, 335; and one of Ba-en-Ramer-Amen (Merenptah), 336: the style of the remaining six scarabs, 337 to 342, confirms that this tomb dates to the late nineteenth dynasty. An unusually shallow gypsum tazzas also belongs with this group.

Tomb 982 has two scarabs of Rameses II, 344 and 345, while the style of the remaining fourteen dates the tomb to late nineteenth dynasty. The large limestone spoon, 343, has a duck's head, which when found bore traces of red and blue decoration; the blue has since dried off, but traces of the red colour-

ing are still visible. The head was made separately from the body of the spoon, to which it was attached by some adhesive matter which had totally decomposed. A bronze bangle, paste amulets, two gypsum tazzas, all in the usual style, and some small lumps of kohl, also come from this tomb (pl. lvi). The smaller of the two tazzas has scratched on its base the arcs of two large circles, which have clearly been laid out with compasses, for cutting two vessels from the block, then abandoned when only one was planned. Among the scarabs are two of User-Maat-Ra setep-en-Ra (Rameses II), 344 and 345; and a wish scarab, 349. The remainder are of common ninth–twentieth dynasty types, with the exception of 353 and 358, which are earlier survivals.

Group 983 has one steatite scarab, 360, and a small one in paste uninscribed; also a pair of bronze ear-rings of unusual form with hollow tapering drops, 360 A. 985 has two paste scarabs, 386 and 387, and the usual amulets and beads.

984 contains five scarabs with the name of Thothmes III, 362, 363, 369, 371, and 372; one of Amenhetep III, 364; six of Rameses II, 365 to 368, 370 and 373; one of User-Maat-Ra-mer-Amen (Rameses III), 374, and one of Rameses VIII, Ramessu-mer-Amen-akh-en-Ra, 375. There were also remains of a second scarab in paste of Rameses VIII: this is the latest royal name which has yet been found in the 900 cemetery, and brings the dating down as late as the latter half of the twentieth dynasty, 1138 B.C. Nos. 384, 385, 390, and 391 are probably early survivals; the remaining seventeen scarabs are characteristic of the period. Two ivory spoons, 361 and 387, are unique here, though common in Egypt in this period. 361 appears to have originally had a cover pivoting on a peg, and fastened by another peg at the other end; the handle had been broken off anciently. Two gypsum tazzas, bronze ear-rings, and bangles of the usual forms also occur in this group, and among the beads is a fragment of an amulet of the hippopotamus goddess, Ta-Urt, in red jasper, shown strung in the middle of the beads in the photograph on pl. lvi.

10. The pottery from this cemetery included one very distinctive type, both in form and decoration, viz. type 37 J, pl. lxxxiv, with the gazelle and bird decoration, pl. lviii. The painting is in dark red (haematite) on a light red or pinkish ground, the body of the pot being generally rather rough and poorly fired. The type of decoration is consistent in each example as regards the gazelles and birds,

but various other animals and motifs are introduced. The bodies of the gazelles are represented by two triangles, and the horns are long and with a sweeping backward curve; the birds are always shown with three tail feathers.

In the first example on pl. lviii, from tomb 978, there are on the left in a narrow frieze four birds in a row, facing right: the bird on the extreme left has its wings raised, and between them are what appear to be three serpents. Above and below this frieze are narrower bands divided into rectangles. A figure of a lion with tail erect is in the central panel, the top right-hand corner of which is filled with meaningless wavy lines. On the right, and balancing the bird frieze on the left, are three gazelles in a row, facing left, with what may be two serpents rising before them; the ground round the gazelles is filled in with dots. Three upright bands contain wavy lines and a ladder pattern. The second example, from tomb 972, shows on the left some kind of plant (? water-lily), with two triangular leaves and two flowers, one of which is drawn both in plan and elevation. The large centre panel is flanked on either side by vertical bands of lattice and chequer pattern; in the panel are shown three gazelles on either side of a tree, possibly a palm. The lowest two gazelles stand with their hind quarters to the tree, their heads turned, looking back; the others appear to be feeding on its lower branches. To the left is a fish, attached to the tree by a long line coming from its head; on the right is another fish, not connected with the tree. The third example, from tomb 920, has a small central panel, showing two gazelles facing a bird. The rest of the decoration is built up of small rectangles filled alternately with diagonal cross and lattice patterns. The fourth example (pl. lxxxiii, 18 G 7) also from tomb 978, shows two birds with raised wings, a gazelle, and a group of short wavy lines, equally spaced round the inside of the bowl.

11. This decorated pottery appears to end about the middle of the xixth dynasty, as the latest scarabs with royal names found with it are of Rameses II, and no examples have been found in the city levels above the cobbled courtyard of the Residency, which dates to Sety II (sect. 14).

There are also examples of imported Mykenaeen ware, and copies of these and of base-ring forms in coarse local ware; and a specimen of white decorated wish-bone-handle bowl. The remaining forms are all of rather coarse red local pottery, moderately well fired; the surface is never burnished or polished, but

a few types are decorated with groups of narrow red bands, pl. lxxxvii.

The glaze on the scarabs and amulets is generally badly decomposed owing to the damp soil, but the remaining traces show it to have been a pale green shade. A few disc beads in tomb 922 retained their original bright blue glaze.

Pl. lx shows a general plan of the 900 cemetery in relation to the great wall on the west side of the Tell, and registers of the tombs are given on pls. xci to xciii.

CHAPTER IX

THE TELL. NORTH END

12. A FURTHER clearance, 30 ft. wide, was made to the south of, and adjoining, the previous season's work, and that part of the great city wall of the Sheshenk period covering the remaining portion of the Residency and its adjoining buildings was removed, and the excavation of the Residency completed. Also an area to the south of the Residency was cleared down through the cobbled courtyard to native soil, revealing two further layers of buildings, one of the late xviiith or early xixth dynasty, and one of the Hyksos period. A register of pottery found at the various levels is given on pl. lxxxix.

13. Plans of the earliest levels are given on pl. lxvi. The level of the native marl in the grain-pit ZZW is 351 ft. 6 ins., sloping up to 353 ft. 9 ins. at the eastern edge of the Tell. The foundations of the first Hyksos building are at 354 ft. 4 ins. and 355 ft., the intervening space being a layer of clean, loose soil, laid presumably for purposes of levelling, the same feature being seen at the south end of the Tell. ZZX is an oven or kiln, the inner faces of the walls being completely calcined by fire, pl. lxxxv, 1, but no objects were found which might have given a clue to its use. The large grain pit ZZW comes down from level 362 and is cut into the *gebel* to level 345 ft. 6 ins. No small objects were found in these levels, but three sherds of decorated pottery, pl. lxiii, 35, 37, and 38, come from the space between this and the next level. These would appear to be late Hyksos to early xviiith dynasty period. From low in the level above came sherds nos. 36, 39, and 40: the lowest foundation courses in this layer are at 361 ft. 10 ins. Also from area ZZM, level 358 ft. 8 ins., comes a fragment of Tell el Amarna ware, with the characteristic bright blue and black bands on red slip, pl. lviii, 1.

37 A. This seems to date the second layer to the end of the xviiith or early xixth dynasty, and contemporary with the earliest tombs of the 900 series. The sherd 42 from ZZW is of a ware similar to nos. 52 to 56, but being from a grain pit is not good dating evidence. Also from the top of this pit came two fragmentary hieratic ostraka, not yet translated. These are now in the Jerusalem Museum.

14. Between this second layer and the xixth dynasty Residency is a deposit of about 18 ins., represented in part by a thin layer of ash and carbonised vegetable matter, seen overlying a wall of the second level in the photograph on pl. lxviii, 15.

This photograph also shows how the ground was levelled down to make the cobbled courtyard. Pl. lxix shows a revised plan of the Residency, with the addition of the bed- and bathrooms, the cobbled pavement, open drain, and adjoining building to the west: photographs of these are given on pls. lxvii and lxviii. The northern rooms were built over the Hyksos bank, the foundations actually stepping up on to it, pl. lxviii, 14, with a consequent rise in floor level of 18 ins. The bedroom had a slightly raised platform of mud brick set in a recess on the north side of the room, with a square step before it, pl. lxviii, 10, similar in style to those of Amarna and one found at Medinet Habu (*O.I.C.*, no. 7, fig. 16). The bathroom, which adjoins the bedroom on the east, consisted of a narrow chamber with a plastered water-tank at the east end, raised some 4 ft. above the floor level, and approached by a very narrow flight of white plastered steps built against the wall. Presumably the bather would stand below while an attendant poured water over him from above. Beneath the tank were traces of what appeared to be brick vaulting, but unfortunately the under-structure was too badly damaged to be able to determine anything definite. It may possibly have been a soak-away similar to that shown in *O.I.C.*, no. 7, fig. 17. The wine store was the small room immediately to the south of the bathroom: in this were found the remains of forty-five large jars which had been stacked in rows on the floor. The collapse of the roof as a result of the burning of the building had smashed them all; many of them had been sealed with conical mud sealings, pl. lxviii, 13. Against the south-west corner of the building was a sloping mud brick revetment with white plastered face, having a channel down the centre to catch rain-water from a gutter on the roof and conduct it into the drain, pl. lxviii, 11; this is constructed

of blocks of local sandstone, faced with a plaster containing a quantity of crushed shell. This drain still continues on under the western scarp of the excavations; time did not permit of our following it to its conclusion. No doubt a similar revetment existed at either the south-east or north-east corner of the building also, for the drain curves to the north as it reaches the south-east corner. The fall of the drain from east to west is 5 ft. 2 ins.; the mean fall would be about 1 in 63.

The outer walls of the Residency on the south and east were double, the inner one being thicker and having a stone foundation course, pl. lxviii, 12. On the south side of the building, west of the porch, the outer wall exists only as foundations, and the stones of the courtyard overlie it.

The small area of plastered pavement between two walls on the west side of the courtyard would seem to mark the entrance gateway, from which a flagged path led across the courtyard to the porch steps. The four flat stones bridging the drain near the entrance gate probably carried the wall which enclosed the courtyard. This wall presumably ran from the south-west corner of the Residency to the gateway, and was continued southward to form the back wall of a small chamber, which had a cobbled floor continuous with the courtyard.

On the courtyard and in the large adjoining building to the west were found seven scarabs and plaques, pl. lxii, 20, 21, 21 A, 25 to 28; and a paste *uzat*, pl. lxiv, 64: all are of the late xixth-xxth dynasty types, with the exception of 26, which may be a Hyksos survival. Also from the courtyard, near the entrance gate, came fragments of a large pottery storage jar, pl. lxiv, 74, inscribed with hieroglyphs contained in two cartouches, which are flanked on either side by notched palm sticks, sign for years. These rest on the heads of tadpoles, sign for 100,000, which in turn rest on *shen* signs, the whole meaning "100,000s of years": beneath each cartouche is a *nub* sign. The right-hand cartouche reads "Setymer-en-Ptah," and the remains of the left-hand one read "... mer-setep-en-Ra." The Sa Ra name of Sety I is occasionally compounded with "setep-en-Ra" (see *S. and C.*, no. 7, and *B.M. Cat. Scarabs*, I, 2035), but when so compounded it is always written "Men-Maat-Ra-setep-en-Ra," and "Mer" does not occur in any recorded examples. The Sa Ra name of Sety II is written alternatively as "User-Kheper-Ra-setep-en-Ra" or "User-Kheper-Ra-mer-Amen" (*B.M. Cat. Scarabs*, I, 2292, and

S. and C., 19, 8). The fragment of a hieroglyph at the top of the left-hand cartouche appears to be the base-line of a seated deity, probably Amen, and the name could thus read "Mer-Amen-setep-en-Ra," or a combination of the two variations of the Sa Ra name of Sety II.

The building adjoining the Residency to the west probably contained the domestic offices, although no doorway in the outer wall has been found, and there is no evidence of direct communication between the two buildings. The area to the south of this building must have remained open for some time after its destruction, as a great number of grain-pits had been dug down into it from the later town level above.

15. The pottery from this level was mostly of Philistine type, pl. lxxiii, including a false-neck vase, pl. lxxiv, 72, similar to one found in tomb 532, *B.-p.*, I, xxii, 199. Some sherds of a very different type of pottery with distinctive decoration also occur, pl. lxxiii, 53 to 56: this is of a fine buff paste, well fired, with decorations in red and black on a buff ground, the whole surface being finely burnished, a ware no doubt foreign to the district. No sherds of the latest phase of the decorated Philistine pottery, such as are illustrated on pl. lxxxviii and *B.-p.* I, xxxi, 289, 295, and 296, were found, nor were there any traces of imported Mykenaeen ware or sherds bearing the gazelle and bird pattern. In the wine store were the remains of forty-five large jars, some of which had conical mud sealings bearing the impress of a large seal which shows a male deity holding a sceptre or spear in the right hand, and standing on a lion, whose tail curves upwards, pl. lxi, 5, 6 (see Max Müller, *Researches*, 40). One gold ear-ring comes from this level, pl. lxxiv, 62.

X 16. The next building level above, X, pl. lxx, produced a fine incense burner, pl. lxi, 4, and a group of pottery from rooms XA and XE, pl. lxxv, 4; a series of querns, rubbers, and hammer-stones are given on pl. lxxv, 6. Also from this level comes a sherd bearing the late Philistine decoration (pl. lxxxviii). Pl. lxxi shows additions to the plans of levels V and W (see *B.-p.* I, lvi): small additions were also made to the plans of other levels, but of so slight a nature that they do not warrant re-issuing the full plans already published in *B.-p.* I.

17. Very few small objects were found during this clearance: metal work is shown on pl. lxxii, and a few miscellaneous objects on pl. lxxiv, including an interesting limestone mace head, 66, picked up on

the surface of the Tell, and a decorated sherd, 60, of the late first century B.C., of a type which occurs largely at Petra. Another ostrakon in Aramaic, pl. lxi, 3, also comes from the surface of the east slope of the Tell, and is consequently not datable. The following is the report and translation by Sir A. Cowley: "The ostrakon has not proved very amenable to treatment. It reads as follows:

לורע בחקלא
 זף בת עשרן ||
 ואחר חעכס — || ||

The first line is all right. In the second line the letters are doubtful—especially the ע, which might be an א, and the ר, which might be a ב—but this is the best I can do to make it into words. In line 3 the stroke at the beginning might be a ב and the first word might be באהרת, but that would not be Aramaic. The following letters are curiously spaced, and חעכס means nothing. At the end something has been rubbed out and the present letters have been written over it. The ס might be a ש. So far as it can be translated, it says:

For sowing in the field
 he borrowed a bath—22—
 Afterwards you will receive (?) 15.

As the first line is certain, it was no doubt written by a farmer, who may not have been very well educated."

18. Pl. lxxvi shows photographs of buildings on the south end of the Tell, excavated during the season 1927-1928, and pls. lxxvii to lxxxii are plans of this area. The fortified gateway, pl. lxxvii, is a square structure in plan, with walls of the usual quality of unbaked mud bricks laid on a sand foundation. The ground had been carefully levelled down for the building, and the sand-bed is everywhere cut down into the native marl. The building consisted of a central passage-way with two recesses on either side, and flanked by four small chambers on the west and probably similar chambers on the east. The stone-paved threshold of the northern entrance was approached by two steps leading up from the south, made of rough blocks of local sandstone. The outer wall at the south-west corner shows a pronounced batter, but this does not continue beyond the junction with the city wall on the west, nor is it apparent in the north walls. The floor levels of the chambers were considerably higher than that of the central passage-way. In the north-east corner of room FE is a projecting angle of brick-

work, and in the south-east corner of room FH is a similar angle: that in FE appears to be complementary to the recessing back of the threshold to the north, thus preserving a consistent thickness of wall at what would otherwise be a weak point. The presence of the same constructional feature in FH suggests a similar recessing at the south end of the passage, which would justify the interpretation of this building as a gateway. This type of gateway is similar in plan to those found at Megiddo and Carchemish (*O.I.C.*, no. 9, fig. 15), although the Megiddo gate is later, being of the xxiind dynasty. These gateways were probably similar in elevation to those shown in Egyptian reliefs of the ninth dynasty (Wreszinski, *Atlas*, 34 and 39).

19. Pls. lxxxiii to lxxxviii show additions to the beads and pottery in the Corpus of Palestinian Pottery; also decorated sherds and a bronze dagger from the Hyksos gateway and adjoining area.

Pl. lxxxiii shows scarabs, amulets, and seals from the town levels at the south end of the Tell, excavated during the season 1927-1928. The scarabs 16 to 21 and 31 and amulets 58 to 70 are part of a group containing also beads and two silver finger-rings, 58 and 65; nos. 21 and 31 date the group to Rameses II, or contemporary with some of the burials in the 900 cemetery: a register of the beads is given on pl. xciii. No. 43 is a steatite scaraboid showing a standing hawk-headed figure, with outstretched arms holding inverted *ankh* signs. A pair of wings hangs from the shoulders, while another pair rises from the upper part of the arms: above the head is a disc. The technique of this work is unusual, and resembles the couchant hawk-headed sphinx on a scarab in *B.-p.* I, xxxv, 427, and cannot be earlier than the xxiind dynasty. Scarab no. 57, with bright green glaze, is part of a group from tomb 701, which includes a large bronze bowl and dipper, of about the fifth century B.C. (*B.-p.* I, lxxi). Nos. 71 to 87, with the exception of 74, 75, 82, and 83, are pot marks from the city levels: 83 is a fragment of Aramaic inscription. The two limestone mace heads, 74 and 75, are from level D, where they are probably intrusive: the pear-shaped form is known from the neolithic site A on the plain to the south of the Tell. 82 is a fragment of an engraved *tridacna squamosa* shell, showing part of an embroidered dress, a lotus bud, and a leaf (compare *Naukratis*, xx). Pl. lxxxiv shows bronze and bone objects also from the south end of the Tell, and pl. lxxxv shows the decoration on three Philistine vases from level D.

CHAPTER X

DATING

20. THE lowest city levels are dated to the Hyksos period, probably late Hyksos, from the evidence of the pottery; and the dating of the upper levels from the xxist-xxiind dynasty and onward to the first century A.D. is well fixed. Neither the early nor middle xviiiith dynasty is represented by a definite building level, but a few sherds which could be attributed to the early xviiiith dynasty have been found, and these are in close association with pottery forms of the late Hyksos series, high in the filling of the rooms of the south-east gateway and adjoining area.

21. It remains, then, to establish the connections in date between the Residency and its destruction, the 900 cemetery in the Hyksos fosse, and the Philistine tombs in the 500 cemetery published in *B.-p.* I. The best starting-point for this is, perhaps, the cobbled courtyard, which effectually seals off everything below from everything above it. Below it were found sherds as illustrated in pl. lxiii, 35 to 42; among them there is not one fragment of decorated Philistine ware. True, only the rooms of the Residency and a small area of the courtyard have been cleared to native marl, but the abundance of Philistine ware on and above the pavement, and its entire absence below, indicate that the levels immediately below are pre-Philistine, and they date to the late xviiiith-early xixth dynasty (see par. 11) and Hyksos. The quantity of sherds of the best decorated Philistine ware on and immediately above the courtyard, and in the building adjoining the Residency, pl. lxiii, 43 to 51 and lxiv, 57, 58, and 72 (compare *B.-p.* I, xxiii), together with the absence of the later degraded patterns (pl. lxxxviii, 1, and *B.-p.* I, xxxi, 289, 295, 296), which do not occur below layer X, suggests that the Residency was destroyed before the close of the Philistine period. On the courtyard near the entrance were found the fragments of a pottery vessel bearing the cartouches of Sety II, 1210 to 1205 B.C. Had this jar been intact at the time of the destruction, more of it might have been found, and one can therefore conclude that it antedates this event by some time. It is questionable as to how far the decorated Philistine pottery also antedates the burning, especially in view of its entire absence from the levels immediately below.

22. Turning now to the 500 and 900 cemeteries,

we find in the 900 series an entire absence of Philistine pottery, but the presence of an entirely different but equally characteristic decorated ware, with the gazelle and bird motif: no iron weapons are found in this cemetery, the earliest example being from tomb 542 (*B.-p.* I, xxi). In these tombs there are great numbers of scarabs with royal names, the latest being of Rameses VIII, 1138 B.C. Therefore they must have continued at least as late as this, while the earliest burials are of the late xviiith-early xixth dynasty (see par. 7). The Philistine tombs in the 500 cemetery (*B.-p.* I, xxii and xxiii), contain a quantity of characteristic Philistine ware, but not a single example of the gazelle and bird pattern; and the only scarabs with royal names are two of Thothmes III and one of Rameses XI (*B.-p.* I, xxii, 184, 188, 202).¹ The latest tomb is, however, considerably later than Rameses XI, 1118 B.C., and Professor Petrie suggests a date of 1050 B.C. (see *B.-p.* I, p. 7). In this account tomb 542 is placed first and dated to 1320 B.C. on the evidence of scarab 184 (*B.-p.* I, xxii): as, however, a similar type to this and to 186 occurs in groups with scarabs of Rameses II (tombs 914, 936, and 960), Mer-en-Ptah (tomb 914), and Rameses IV (tomb 960), it is clear that they cannot now be accepted as evidence for an early date.² They can and do occur at least as late as Rameses IV, 1163 B.C. Tomb 552 is dated to 1240 B.C. on the analogy of scarabs 191 and 194: these types, however, are both found in groups with scarabs of Rameses IV in tombs 936 and 960, and so could well be much later than 1240 B.C. 532 has a scarab of Rameses XI, with which date it is probably contemporary, and 562 is dated to 1050 B.C.

23. Evidence for dating the building of the Residency is as follows:

1. The name of Sety II, on the jar.

2. The absence of gazelle and bird decoration and of imported Aegean ware, which is as late as, but apparently not later than, Rameses II, 1295-1229 B.C.

3. Mer-en-Ptah is known to have been active in Palestine (Petrie, *Six Temples*, 26), and Sety II is alleged to have built a fortress somewhere in Palestine (*Pap. Anast.*, v, II, 19; and Wiedemann, *Geschichte*, 481).

¹ The small number of scarabs in the Philistine tombs as compared with the 900 tombs is significant.

² It should be noticed that the scarab in 542 is of excellent work, while all those of 914 and 960 are coarse and ill-formed, evidently much later.—F. P.

Thus a date immediately after Rameses II is suggested, about 1217-1204 B.C., for the building of the Residency.

Evidence for the date of the destruction is as follows:

1. Absence of the late degraded decorated Philistine ware, of which the earliest dated example is from tomb 532 (*B.-p.* I, xxii, 195), which is of Rameses XI.

2. The presence in city, level X above the Residency, of pottery types also found in the 900 cemetery, which ends with Rameses VIII, 1154 B.C. (see register, pl. lxxix).

Thus a date is suggested some time before Rameses VIII, and very probably after the close of the strong control which Rameses III, 1195-1163 B.C., held over the country. The raid which this king made into south Palestine was only concerned with the tribes of the Shasu (Bedawin) (Breasted, *Records of the Past*, IV, p. 404), and it is anyhow unlikely that he would have destroyed what was clearly a centre of Egyptian authority (*B.-p.*, I, pp. 17, 49).

24. It appears, then, from the stratified evidence of the Residency area, that the decorated Philistine ware begins about the reign of Sety II, 1210 B.C., and it is obvious that the tombs containing this ware in the 500 cemetery must date from the same period. The fact that the 900 cemetery continues on to Rameses VIII, 1138, shows that it must overlap the 500 tombs from Sety II onwards to Rameses VIII, a period of fifty-nine years. Examination of the common undecorated pottery found shows that the following forms occur both in the 900 cemetery, the 500 tombs, and in the Residency—6 F, 23 J 14, 25 H 1, 43 H 1—while the following forms occur in the 500 tombs and the 900 cemetery, but not in the Residency: 3 A 2, 12 N 2, 12 M 4, 12 T, 22 T 2, 34 B 3, 43 P 5, 50 D 2, F, G 2, J, U, 52 G 2, 55 V, 59 N 1, 59 T, 65 D 3, 85 H 10, 91 G 5, H 3, K 3. Thus out of some 350 odd forms recorded from these three sources, only four are common to all three, and twenty-one occur in both series of tombs—a result which is quite consistent with the small overlap of fifty-nine years stated above. The plans of the small group of five Philistine tombs out in the plain, and the fact that they are placed in alignment, also confirm the continuity of the tombs of the 500 and 900 series.

The fact that decorated Philistine ware does not occur in any of the 900 tombs in spite of the overlap

in time may be accounted for, in that the northern end of the 900 cemetery has not yet been completely cleared: further work may therefore provide the link, as the sequence in date of these tombs appears to run from south to north.

The following table summarises conclusions as to dating:

		900 cem.	Residency.	Philistine tombs.
XIXth Dynasty.	Rameses I 1318	x		
	Sety I 1317			
	Rameses II 1295			
	Mer-en-Ptah 1229	Gazelle and	Bird Pottery	ends
	Sety II 1210		x	x
XX	Rameses III 1195		Philistine Pottery begins	
	" IV 1163		x	
	" VIII 1138	x		
	" XI 1118			
	Pasebkhanu 1057	Degraded Philistine	Ware	begins x

[The evidence of two periods of construction of the fort must be taken into account. The first period is of good brickwork. This was ruined, and only left above the floor level in a few parts. Later it was re-erected with rammed earth, on the old, deep foundations and broken walls. Whether the destruction between the building periods was in the

Akhenaten insurrection, or later, is in question. It is difficult to place it later. See *Beth-pelet* I, section 49.—F. P.]

25. *List of Abbreviations and Contractions used in Plates.*

- A.—Amber. Ag.—Agate. Am.—Amethyst.
 Av.—Gold. Æ—Bronze.
 B.—Blue. Bo.—Bone. Bk.—Black. Br.—Breccia.
B.M. Cat. Scarabs.—British Museum Catalogue of Scarabs.
 C.—Carnelian. Ch.—Chalcedony. Ca—Calcite.
 Cr.—Crystal.
 F.—Felspar. Fe—Iron.
 G.—Glass. Gl.—Glaze. Ga.—Garnet. Gr.—Green.
 H.—Haematite.
 J.—Jasper.
 L. or Lmst.—Limestone.
 O.—Onyx.
O.I.C.—Oriental Institute of Chicago, Bulletin.
 P.—Paste.
Pap. Anast.—Papyrus Anastasi.
 Q.—Quartz.
 R.—Red.
 S.—Sard. Se.—Serpentine.
S. and C.—Scarabs and Cylinders, Petrie.
 W.—White.
 Y.—Yellow.

26. Pls. xciv and xcv contain bead registers of the tomb published in *B.-p.* I; pl. xcvi shows a series of Arab tribal marks engraved on stones found in the region of Tell Fara.

Distribution List of Tomb Groups

- A.—Anthropological Museum, Aberdeen.
 Bd.—Gospel Mission, Bedford.
 Bl.—Municipal Museum, Belfast.
 By.—Wilton Park Museum, Batley.
 C.—Ethnological Museum, Cambridge.
 Ch.—Chadwick Museum, Bolton.
 H.—Municipal Museum, Hull.
 Ho.—Horniman Museum, London.

- J.—Palestine Museum, Jerusalem.
 K.—Imperial Museum, Kyoto.
 M.—University Museum, Manchester.
 N.—University Museum, New York.
 O.—Ashmolean Museum, Oxford.
 R.—The Museum, Rochdale.
 S.—The Museum, Sunderland.
 W.—Wellcome Museum, London.

905 J., 906 Ch., 907 J., 908 Bl., 909 J., 911 R., 916 Bd., 917 C., 918 W., 919 J., 921 W., 923 A., 924 J., 926 A., J., 926 B., K., 928 M., 931 M., 932 W., 936 J., 938 K., 939 O., 941 J., 942 W., 944 By., 945 H., 946 Bd., 950 W., 951 H., 952 O., 953 A., 954 J., 955 Ch., 956 J., 957 K., 958 M., 959 Ho., 960 J., 961 A., 963 A., 964 W., 965 Bl., 967 J.,

969 Ho., 970 H., 973 H., 974 J., 975 Ch., 978 J., 979–83 N., 984 J., 985 N., 1001 S., 1002 J., 1003 A., 1006 W., 1007 J., 1009 K., 1010 W., 1012 Ch., 1014 R., 1016 H., 1017 H., 1018 J., 1019 Bl., 1020 R., 1023 Ch., 1024 J., 1025 By., 1026 A., C., 1027 J. The remainder at University College, London.

INDEX TO PREHISTORIC FARA

- Site A, 3, 10
 Adze, green basalt, polished, 6, 16
 Alabaster vessels, 12, 20
 Analyses of copper ores, 16
 Arrow-head, tanged, 5, 6, 12, 19,
 20
 winged, 13, 17
 Awls of bone, 7, 12, 17
 Axe, conoid, of syenite, 10, 18
 Axes, *see* Hoes
- B site, 3, 9
 Barley, 14
 Basalt turn-table, 7, 17
 vessels, 9, 10, 11, 12, 16, 20
 borers, 6, 8, 9, 10, 17
 Bead working, 3, 8, 12, 19
 Burials, 11
 Burnished pottery, 12, 14
- Caleb tribe dogs, 16
 Carnelian, 8
 Cereals, 14
 Chrysocolla, 16
 Conical cups, 15, 16, 17, 20
 Copper, entry of, 11
 ore, 12
 working, 12
 Cores of flint, 5
 Cups with loop handle, 7, 8, 10, 15
- D site, 1, 4
 Dagger of copper, 12, 15, 19
 Denudation, 2, 3
 Desch, Prof., analyses by, 16
 Dog figures, 5, 6, 7, 8, 11, 12, 16,
 17, 18, 19, 20
 Domed grain-pits, 14
 Dwellings, 12
- E people, peaceful settlers, 11
 E site, 2, 6, 15
 Egypt, connections with, 15
- F site, 4, 15
 Fabricators for tools, 9, 10, 19
 Fan scrapers, 5, 8, 9, 10, 15, 18, 19
 Felspar, green, 8
 Figurine, 8, 11, 12, 17, 18, 20
 Fire stands, 11, 19
 Fish-hook of copper, 12, 20
 Fish-scalers, 14, 20
 Flakes, long, 10
 factory, 10
 qualities, 6, 9
 Flint, rude work by Copper Age,
 14, 15
 striking, 5, 10, 16
 tabular, 5, 6, 16
 work, changes in M, 8
- Grain-pits, domed, 14
 Grinding of flint, 5, 7
- H site, 4, 11
 dwellings, 12
 Haematite, 9, 10, 12, 19
 Hairpins, 20
 Handles, wavy-ledge, 12, 15
 Hearths, 3, 4
 broad flat form, 10
 changes in M, 8
 extinguished by Copper
 Age, 11
- Hoes, isosceles, 5
 parallel-sided, 8, 9, 18, 19
 triangular, 4, 7, 16
 section, 9, 18
 piled together, 10, 19
 Hour glass possible, 12
- K site, 4, 15
 Knife of flint, 12, 13
- L site, 4, 15
 Lance, fish-tail, 20
 Ledge handles, 12, 15
 Limestone ring-stones, 5, 16, 19
 vessels, 5, 7, 9, 10, 12
- M site, 2, 8
 Mace heads, 10, 12, 15, 18, 19
 Malachite, 16
 in sand-rock, 7, 16
 Mark on pottery, 8
 Matting impress, 5, 7
 Microliths, 5, 6, 7, 9, 10, 19
 Millet, burnt, 14, 21
 Mousterian type, 4
- Netting mesh, 20
- O site, 2, 7, 15
 Ostrich shell beads, 19
 engraved, 20
- P site, 4, 15
 Painted Gothic lines, 7, 17, 21
 Palaeolithic revival by copper
 users, 14
 Palette of chlorite schist, 11
 Petrie, Prof., notes by, 15
 Plaiting, 7
 Pointed flint, 9
 Polished stone adze, 6
 Potters' turn-table, 7, 17
 Pottery, burnished, 12, 14
 fine quality, 7
 whole-made, 5
 site D, 5, 6

- Pottery, site E, 7
 O, 7
 M, 8
 B, 9
 A, 10
 H, 12
- Rock crystal for beads, 8
- Scrapers, angular, 7, 11, 19
 fan, 5, 8, 9, 10, 15, 18, 19
 oval, 11
- Scrapers, paw, 18
 round, 11
- Serpent's head, pottery, 17
- Shell scrapers, 14, 20
- Shellal, 1, 4, 11
- Sickle flints, 5, 6, 8, 9, 11, 17, 18,
 20
- Sites preserved, 1
- Spoon of pottery, 5, 16, 17
- Springs of Shellal, 1
- Stands for pottery, 4
- Strainer, 10, 17, 18
- Stratification of sites, 1-4
- Striking tools for flint, 9
- Syenite axe, 10
- Tent squatters, 2
- Trachyte fire-stands, 11
- Turn-table for pottery, 7, 17
- Water supply, 1
- Wavy ledge handles, 12, 15
- Whorls of pottery, 7, 20

INDEX TO BETH-PELET CEMETERY

- Akhenaten, 32
 Amenhetep II, 25
 III, 24, 26
 Aramaic, 30

 Base-ring ware, 23
 Basket, 25
 Bathroom, 28
 Bedroom, 28
 Bowl, bronze, 23, 26
 Bread, 25

 Carchemish, 30
 Corpus of Palestinian pottery, 30
 Cowley, Sir A., 29
 Cylinder seal, 24

 Drain, 28
 Duck spoon, 26

 Fosse, 22, 23, 30

 Gateway, 29, 30
 Gazelle and bird, 23, 24, 26, 27
 pattern, 29, 31, 32

 Glaze, 27
 Granular work, 24

 Hippopotamus, 23, 25

 Iron, 31
 Ivory spoons, 26

 Jar, inscribed, 28
 sealings, 29
 Jerusalem Museum, 28

 Medinet Habu, 28
 Megiddo, 30
 Mer-en-Ptah, 23, 26, 31, 32
 Mykenaeen ware, 24, 27, 29

 Naukratis, 30
 Neb-ka-Ra, 25

 Ostraka, 28, 29

 Pasebkhanu, 32
 Petra, 29
 Petrie, Sir F., 31
 Piece-work, 22

 Rameses I, 24, 32
 II, 23, 24, 25, 26, 27, 30,
 31, 32
 III, 24, 26, 31, 32
 IV, 24, 25, 26, 31, 32
 VIII, 26, 31, 32
 XI, 31, 32
 Rattles, pottery, 23, 25, 26
 Resheph, 25
 Residency, 27, 28, 29, 30, 31, 32

 Se-kha-en-Ra, 24
 Setekh, 25
 Sety I, 24, 28, 32
 II, 24, 27, 28, 29, 30, 31, 32
 Shasu, 31
 Sheshenq, 27

 Tell el Amarna, 27, 28
 Thothmes III, 23, 24, 25, 26, 31
 IV, 25
 Tut-ankh-Amen, 24, 25

 Wine store, 28, 29

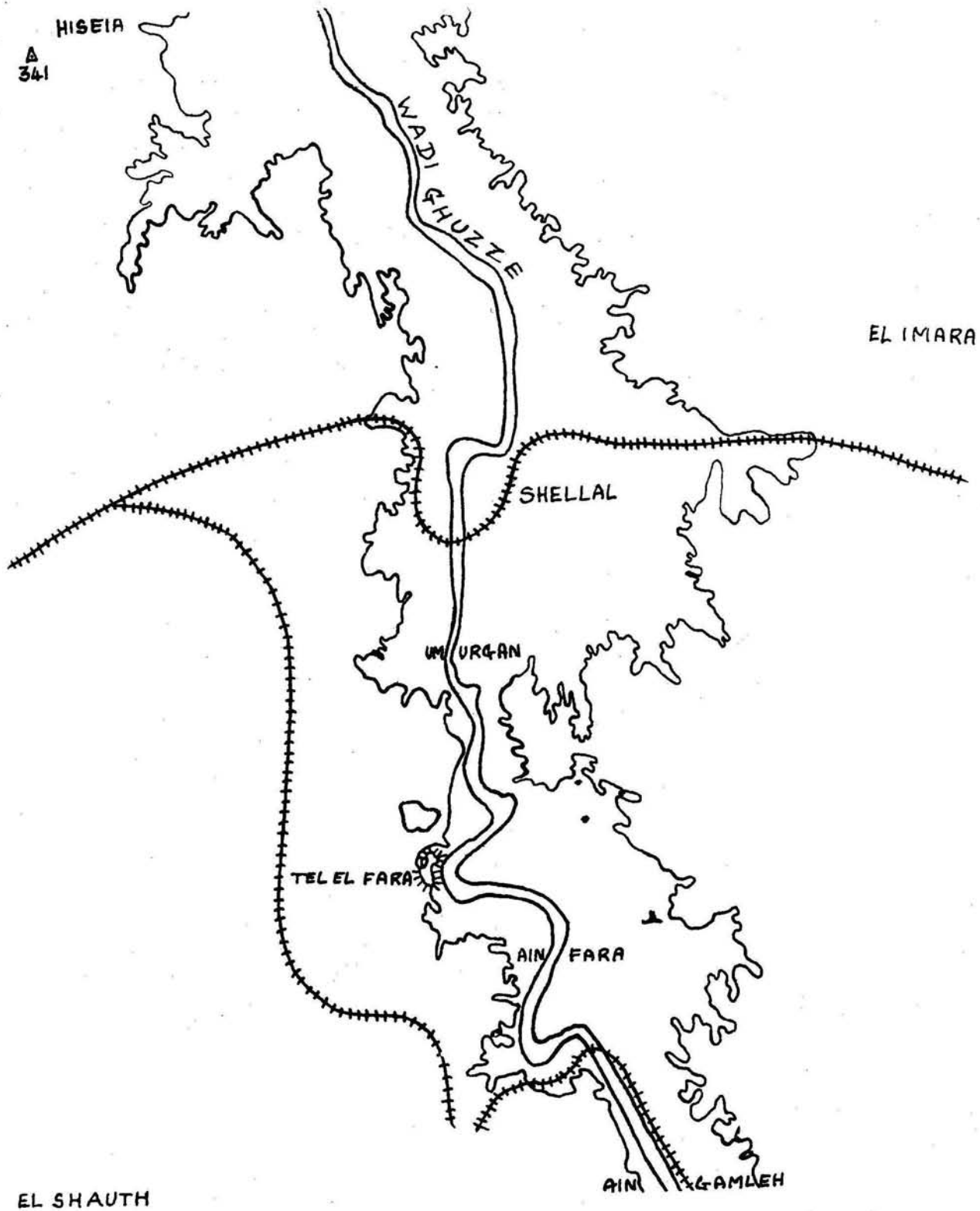

1:100 FARA-SITED, HASANIEH II.

FIGURES REPRESENT POSITIONS OF RECORDED OBJECTS
SITE D.I PITS ARE SHOWN BY DOTTED LINES

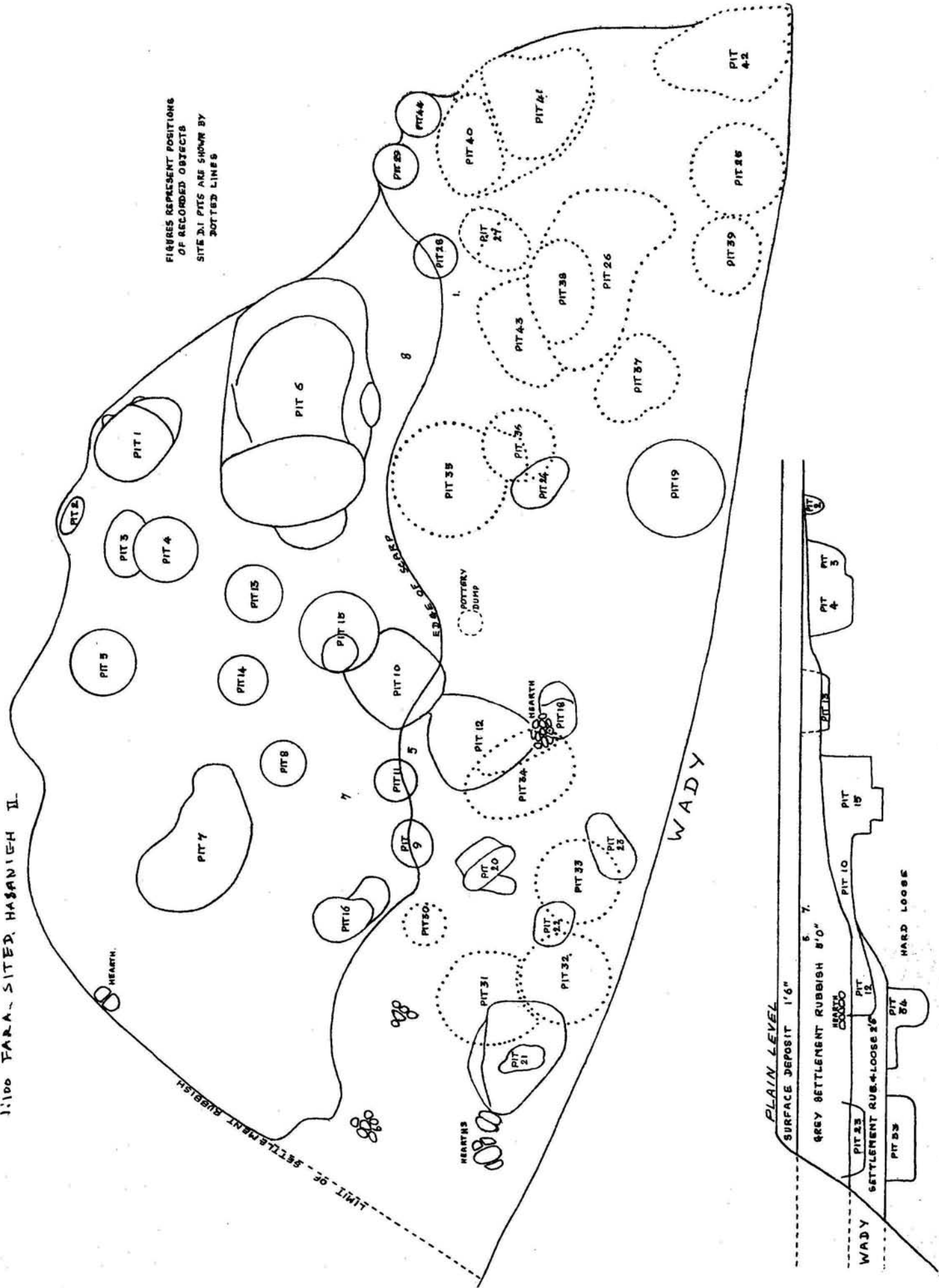

1



2



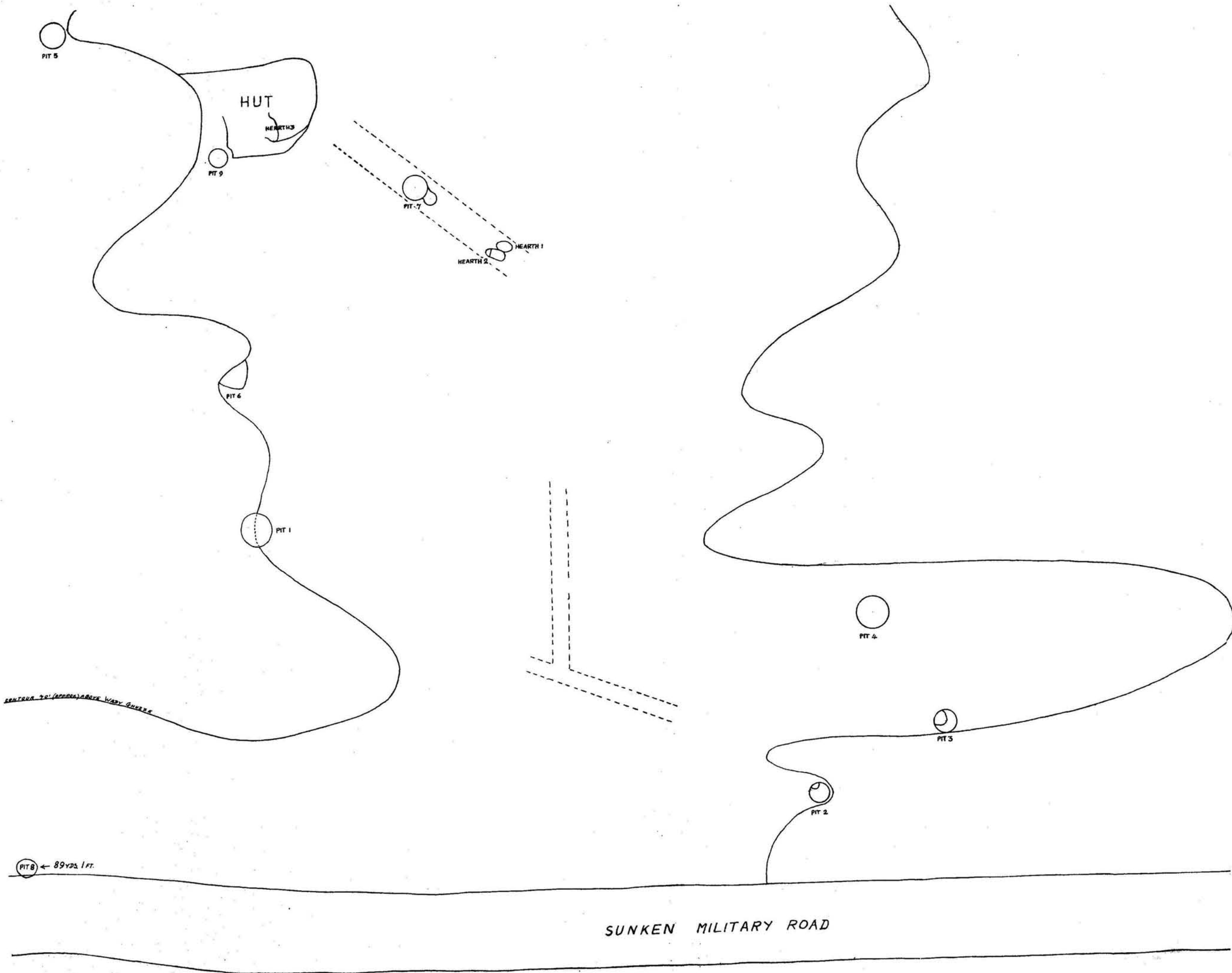

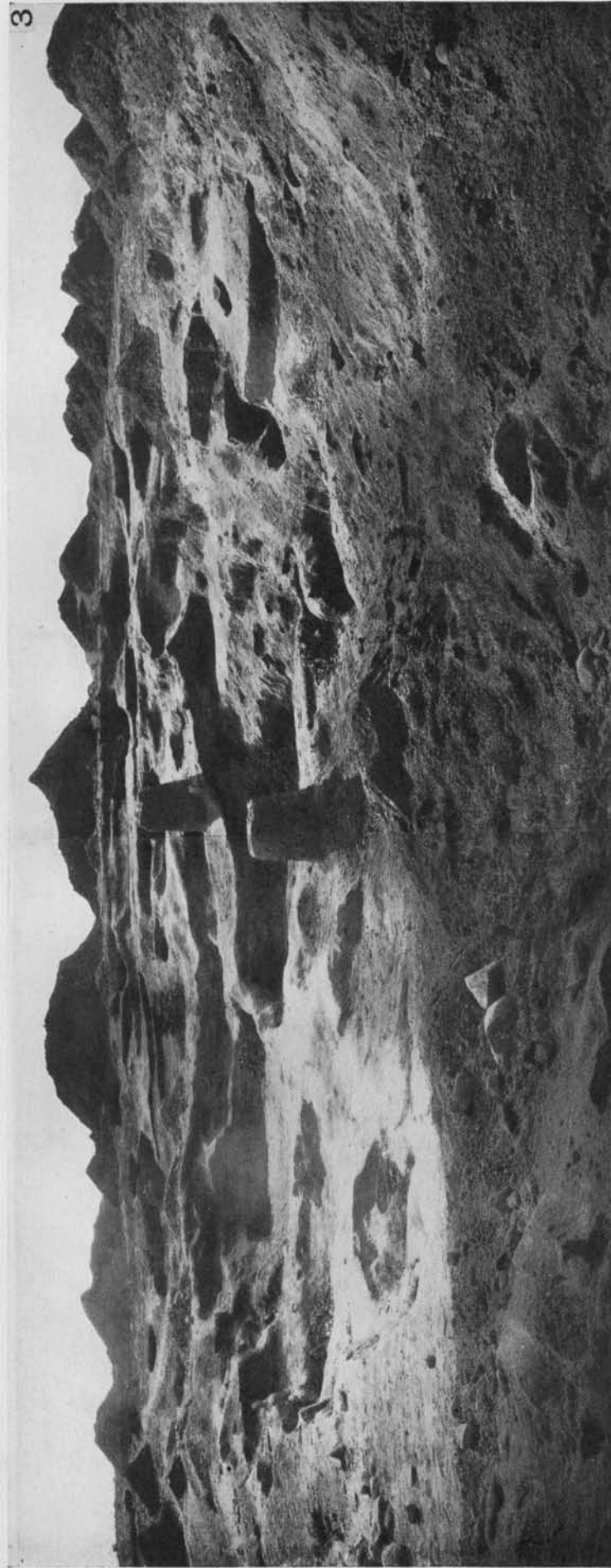

SITE O, HADRUSIEH.

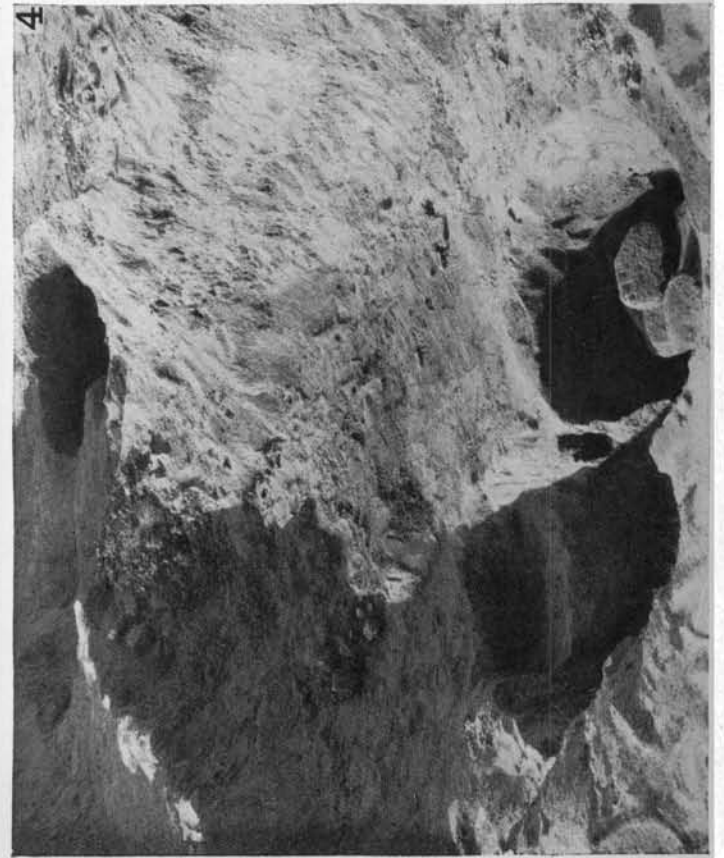

SITE E, IBRAHIMIEH.

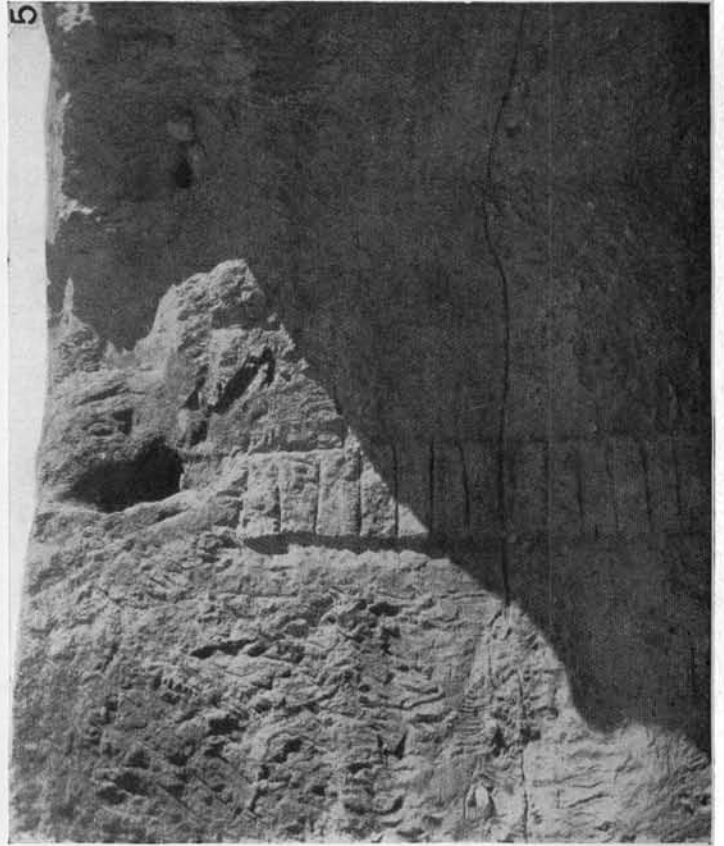

SITE M, 2ND FLOOR, AWADIEH.



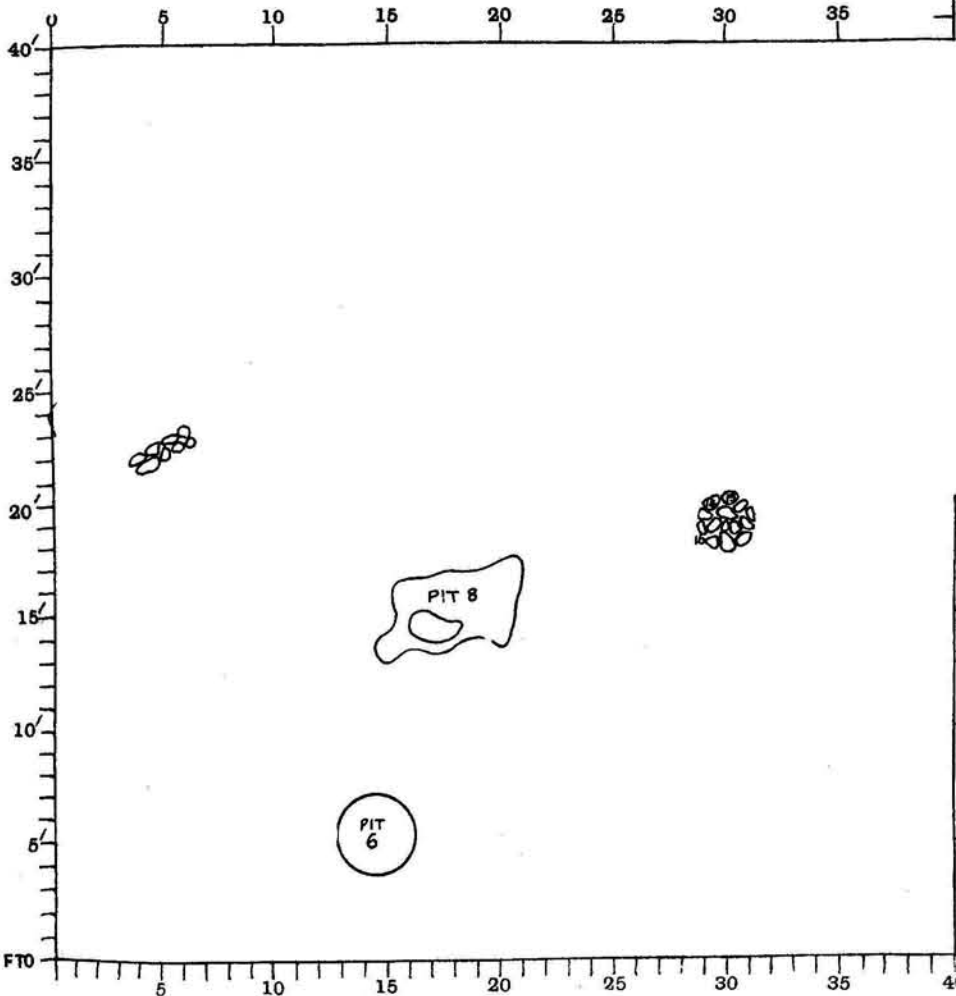
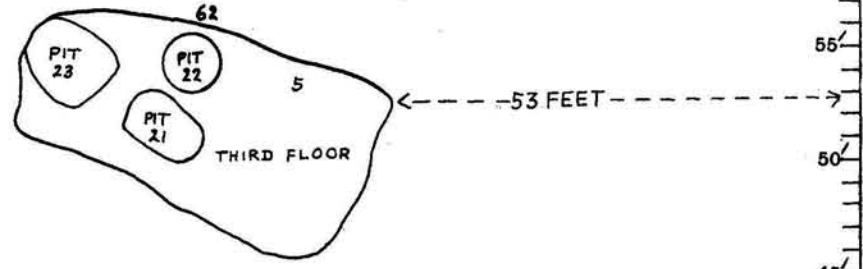
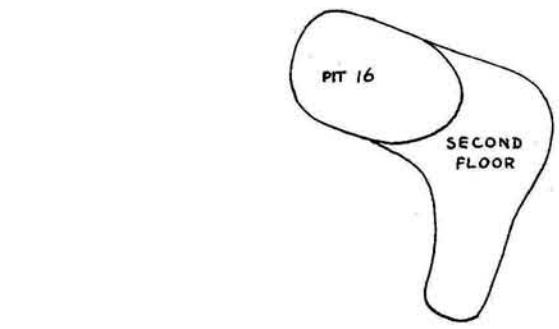
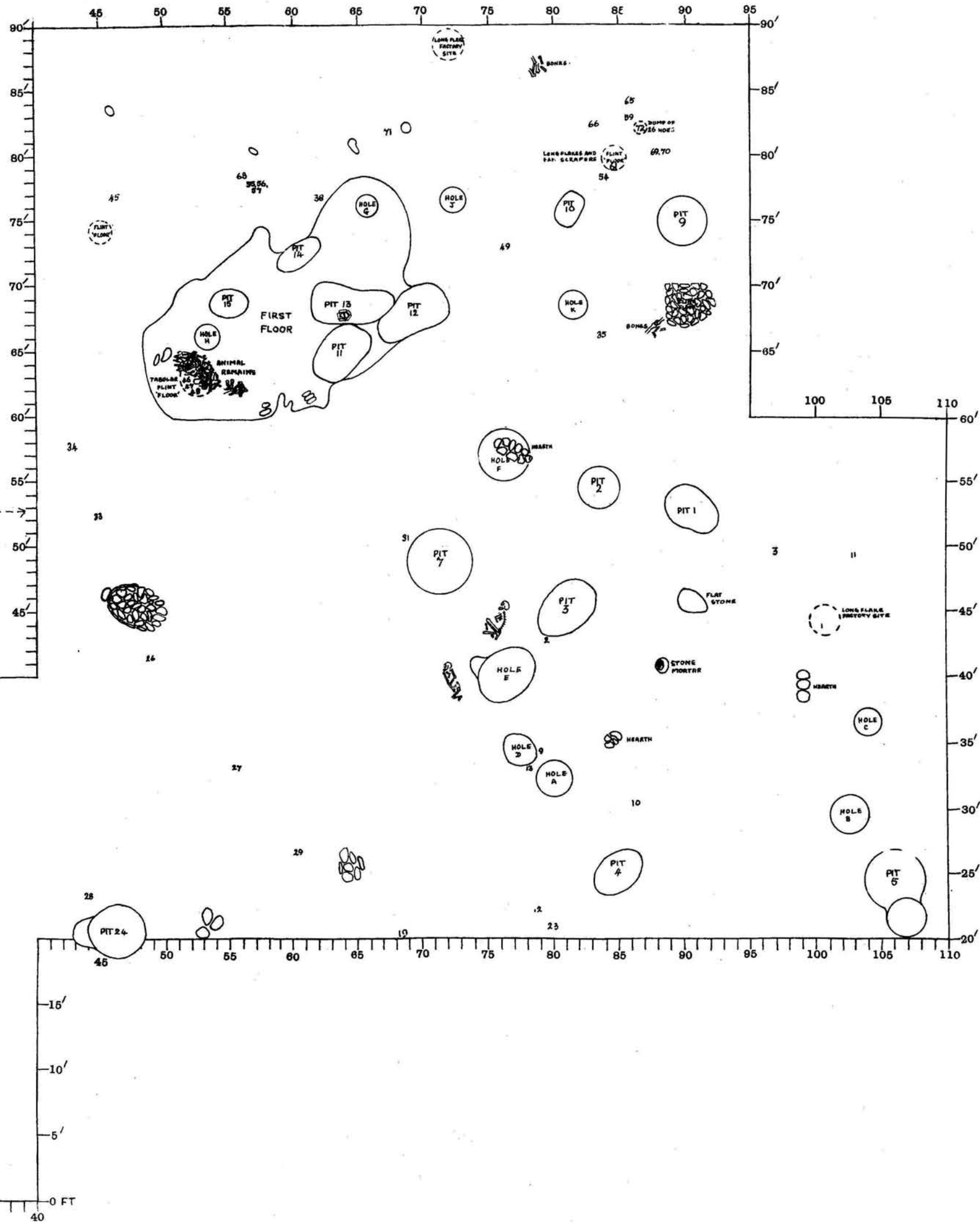

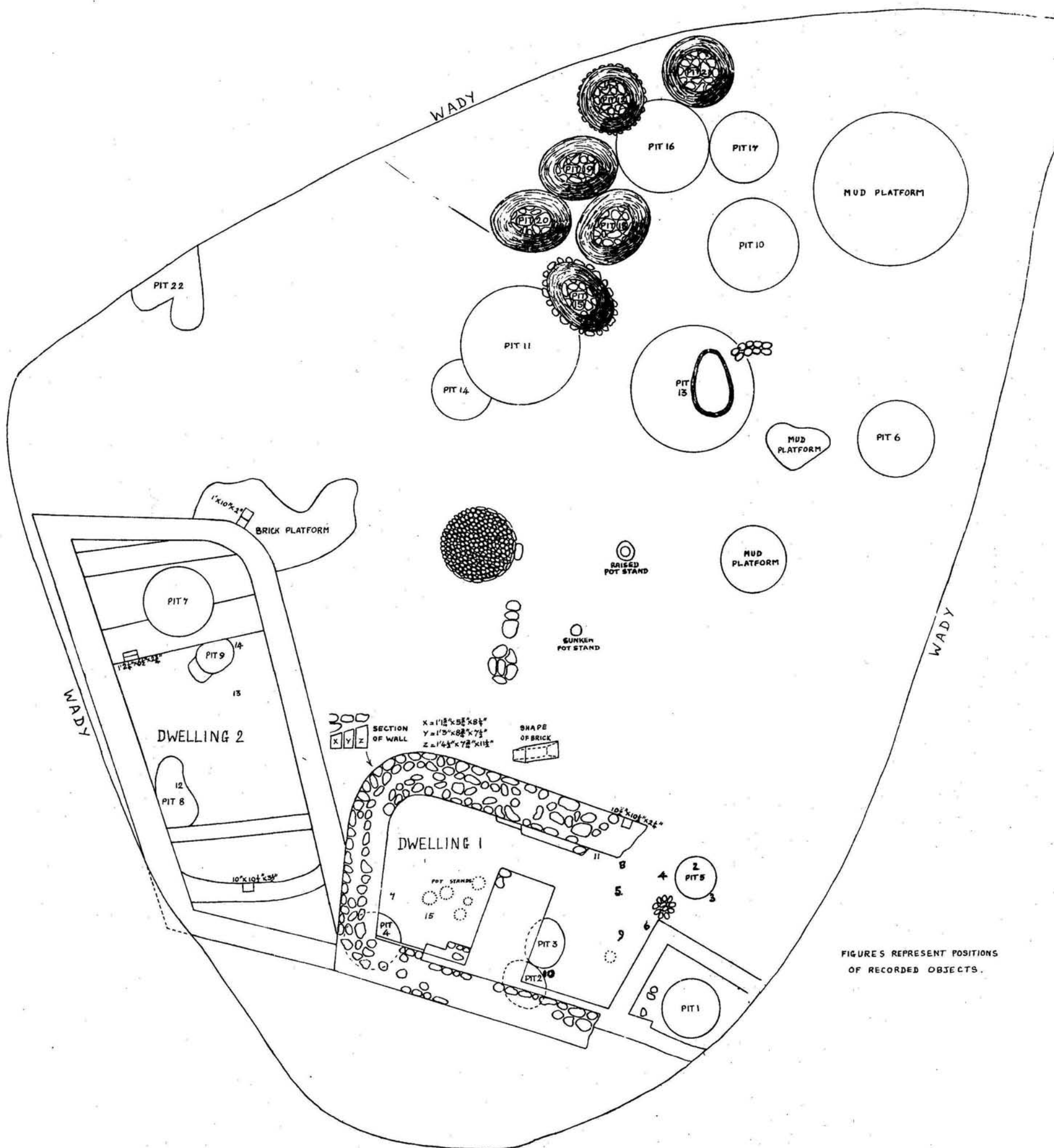



1, BRICK ASH.
2, GREY ASH.

3, RUBBISH AND EARTH.
4, TOP DUST.



SITE E.

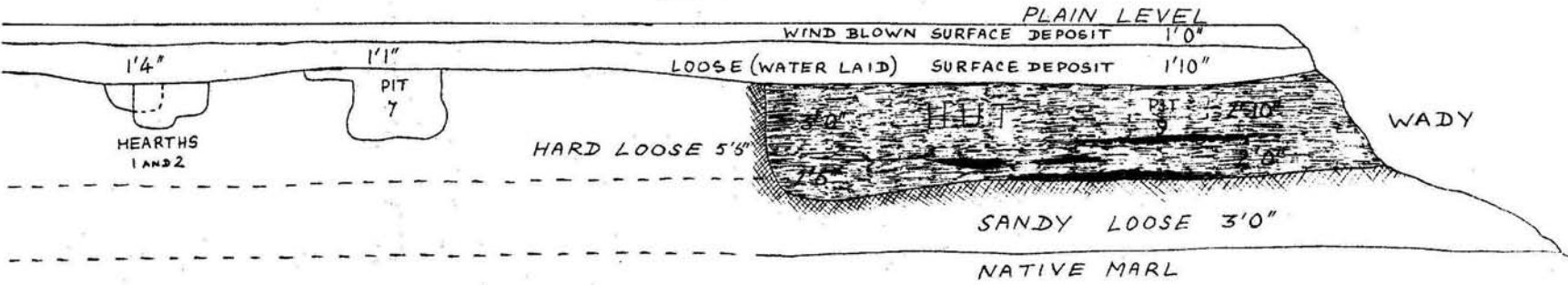

SITE O

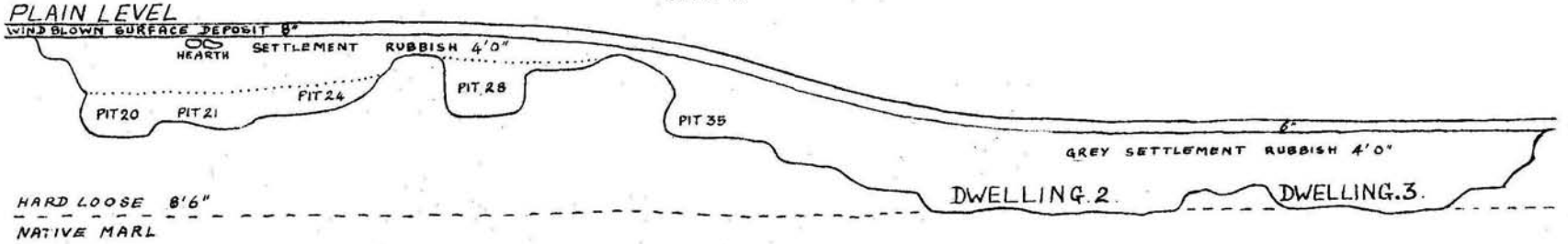

2ND FLOOR, SITE M.

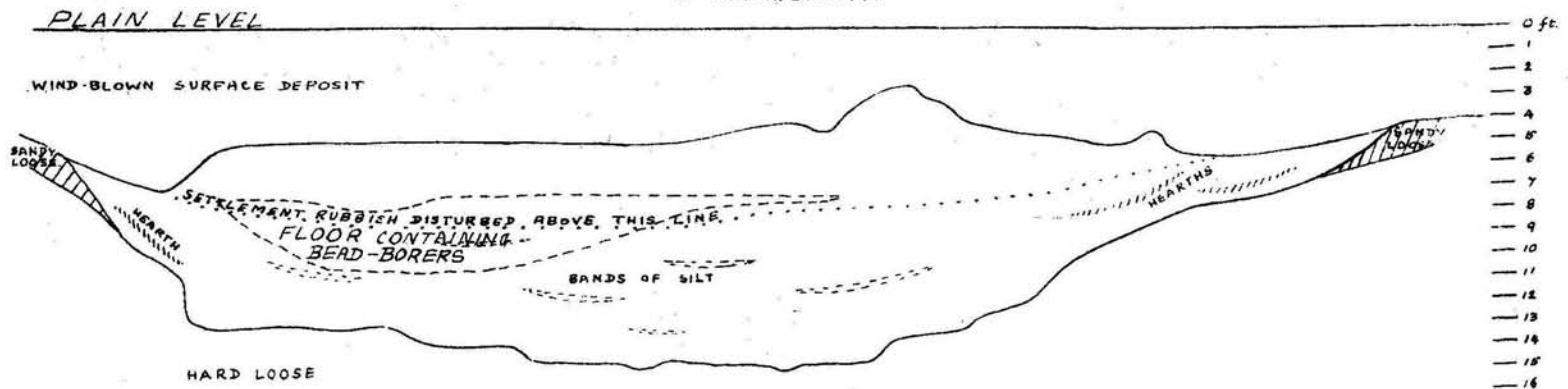

SITE B.

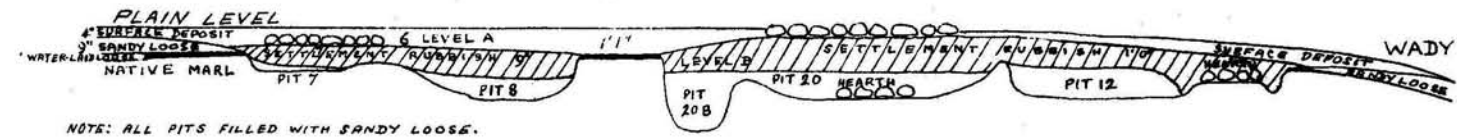

SITE A.

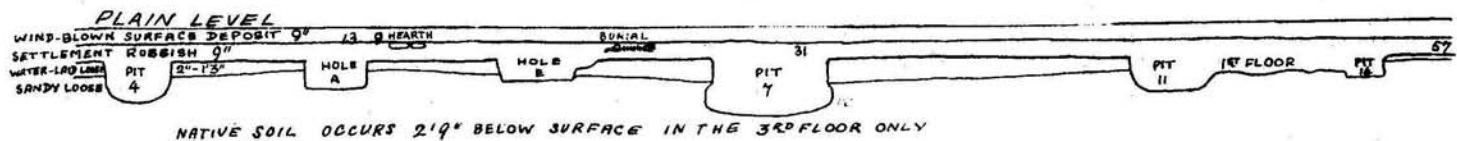

SITE H.

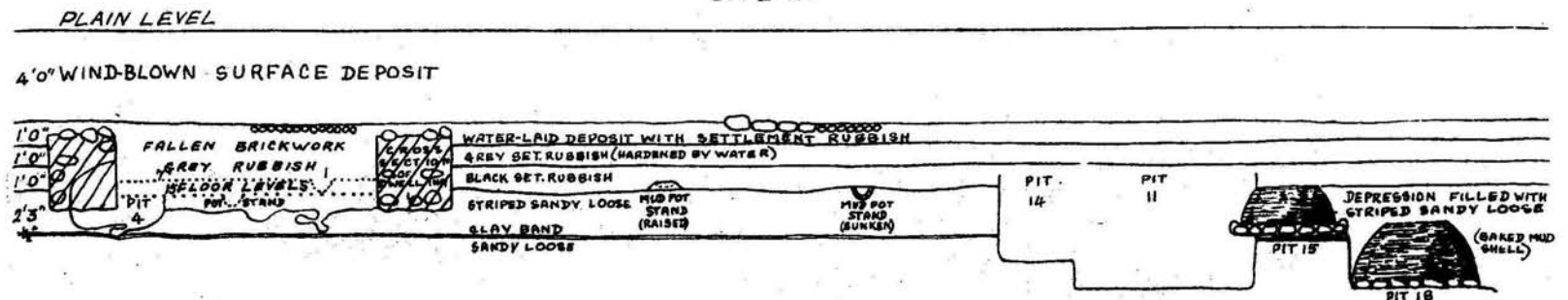

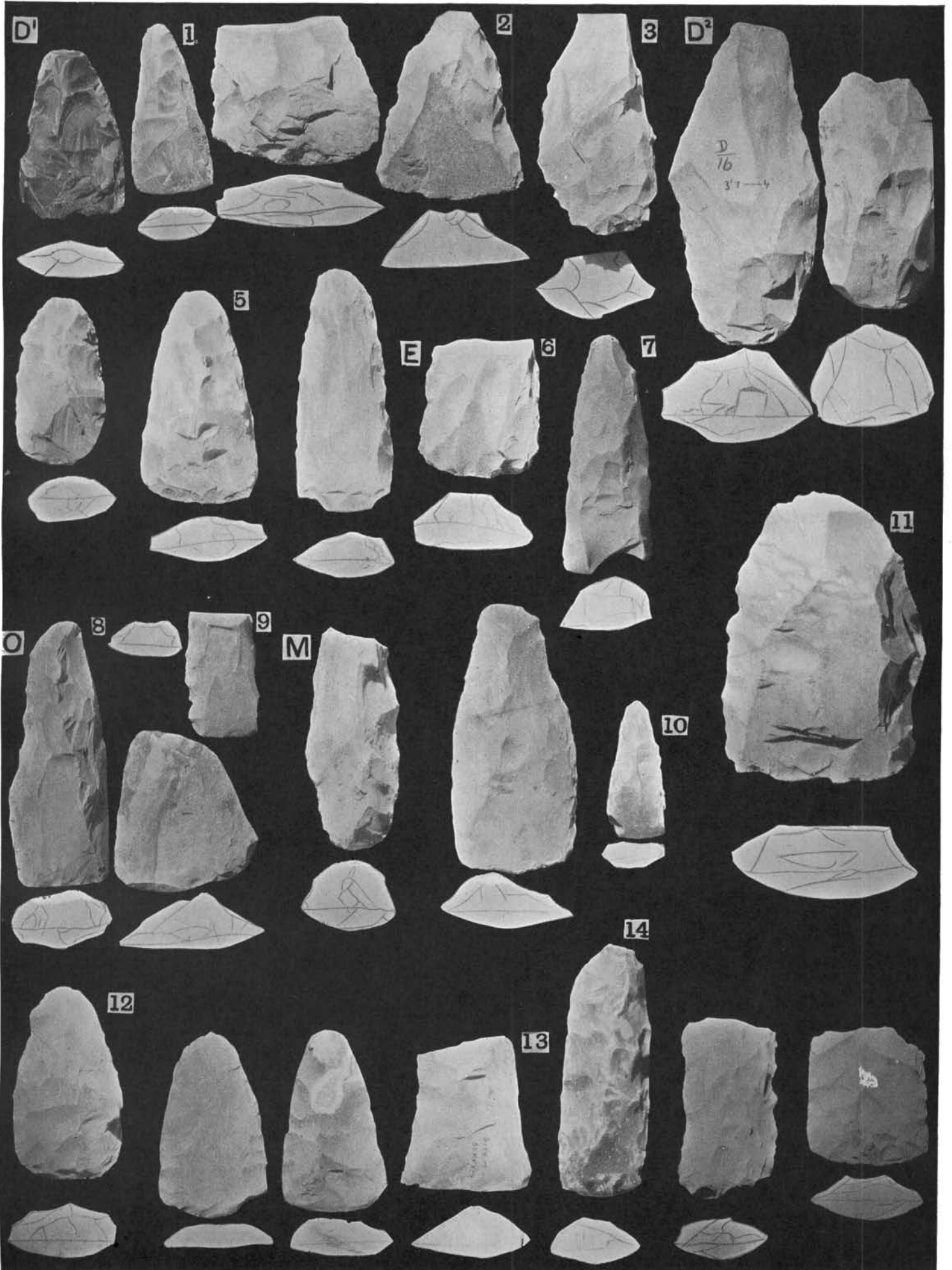



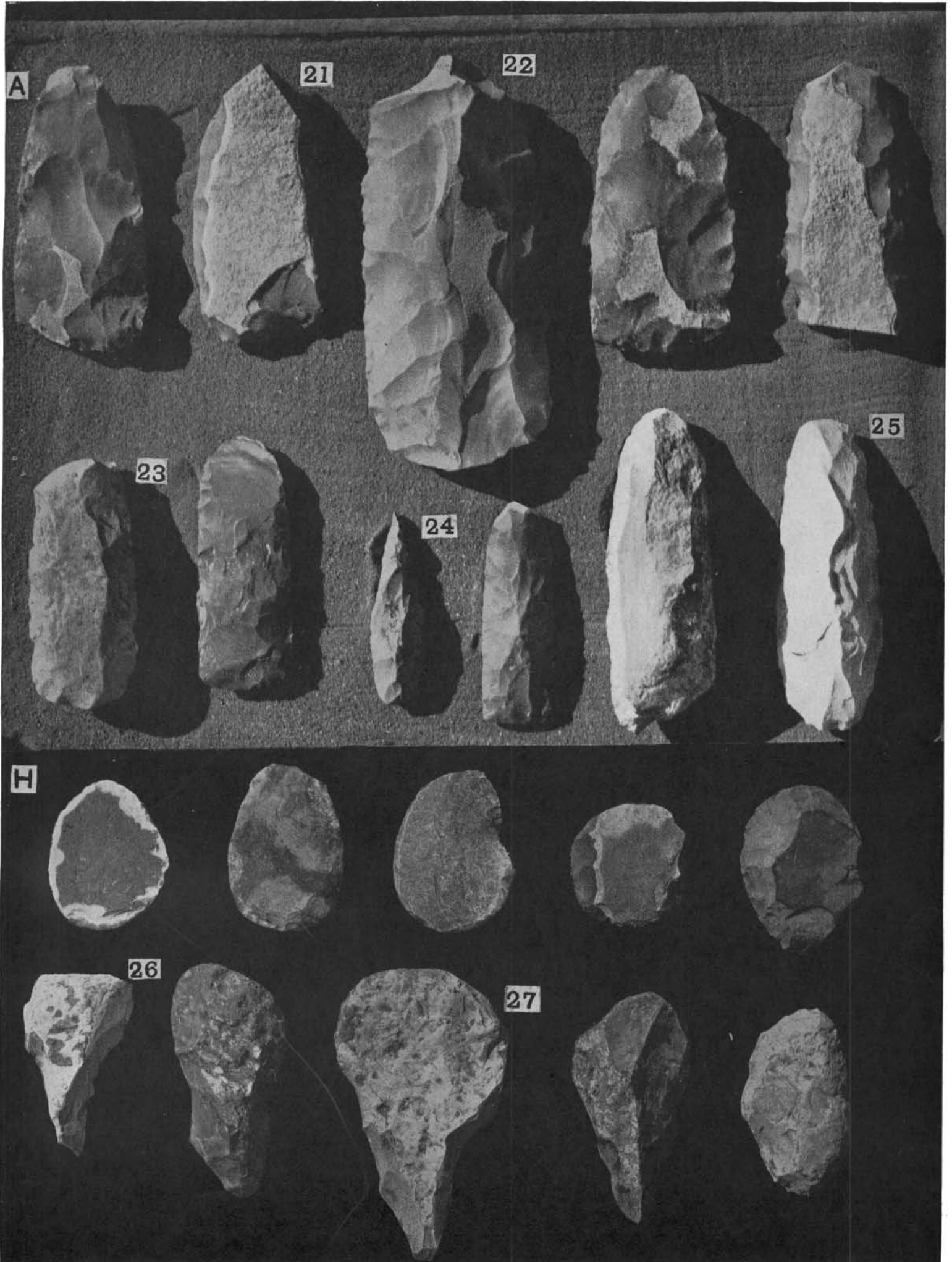

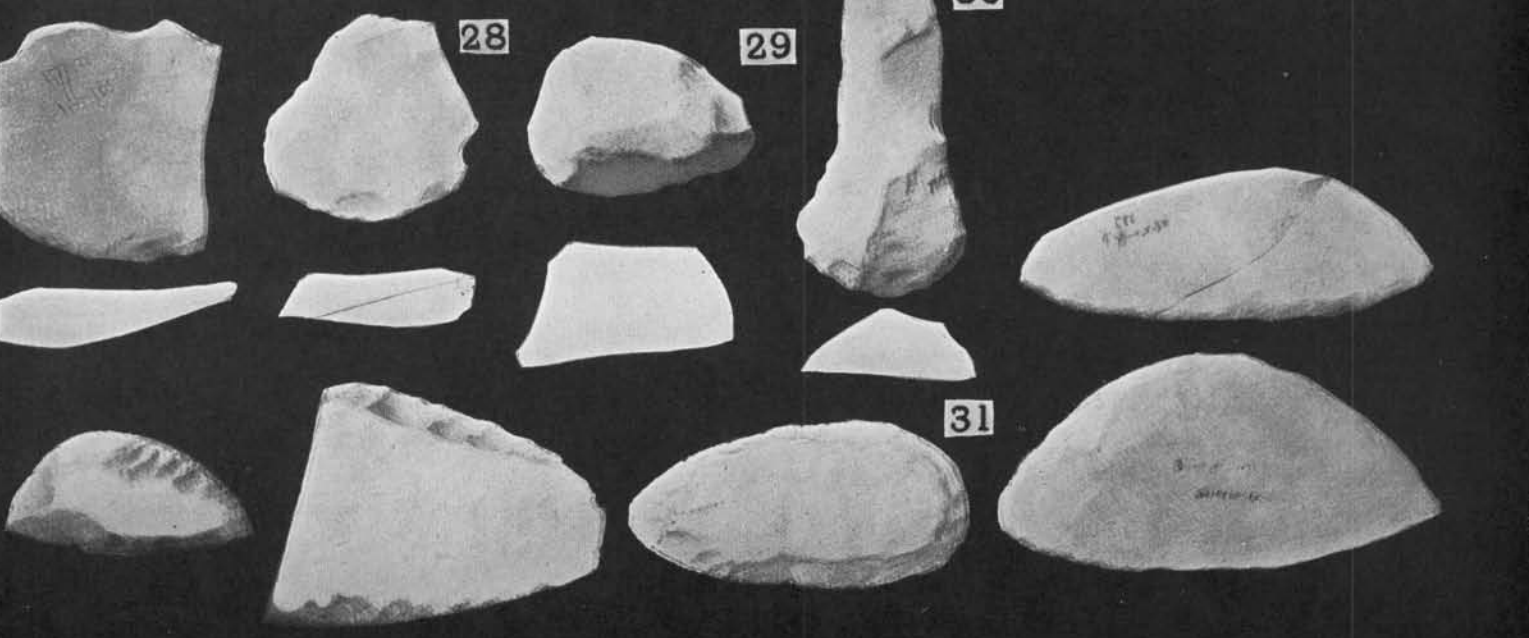
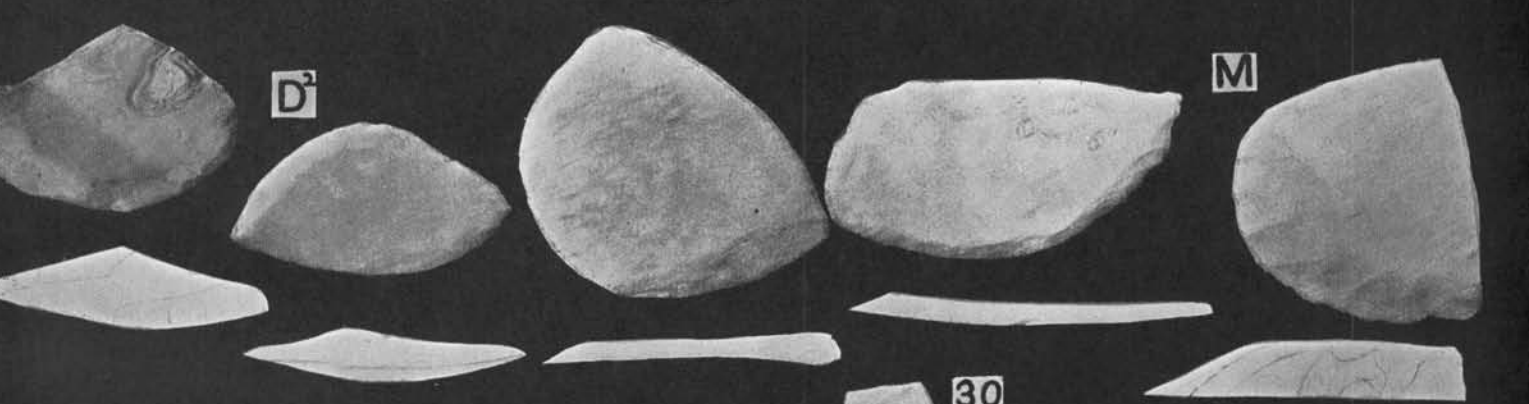
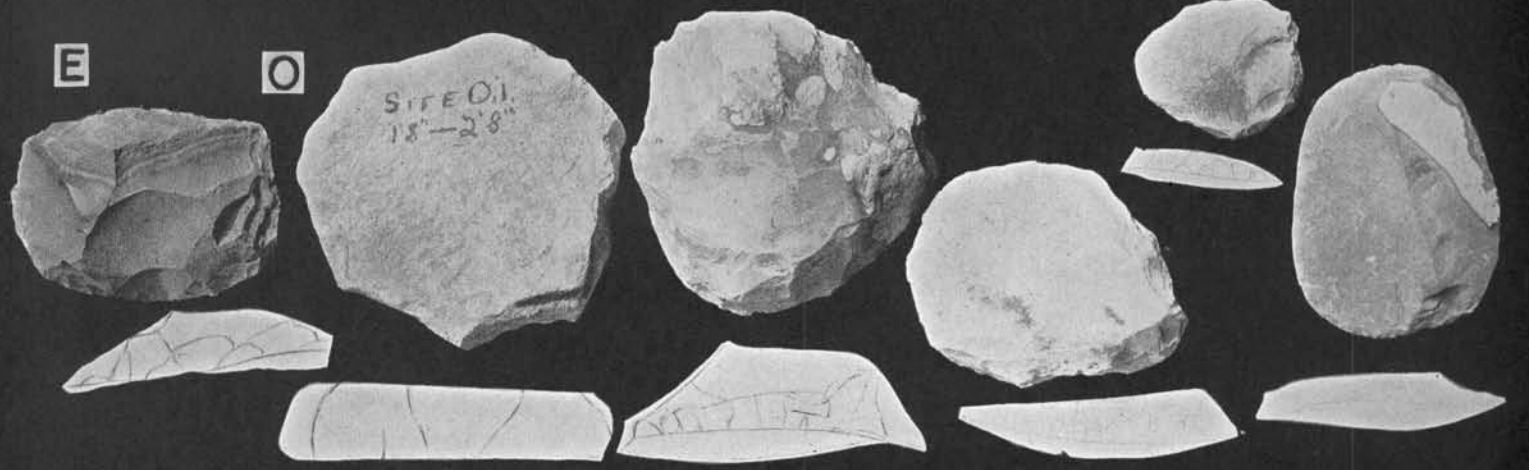
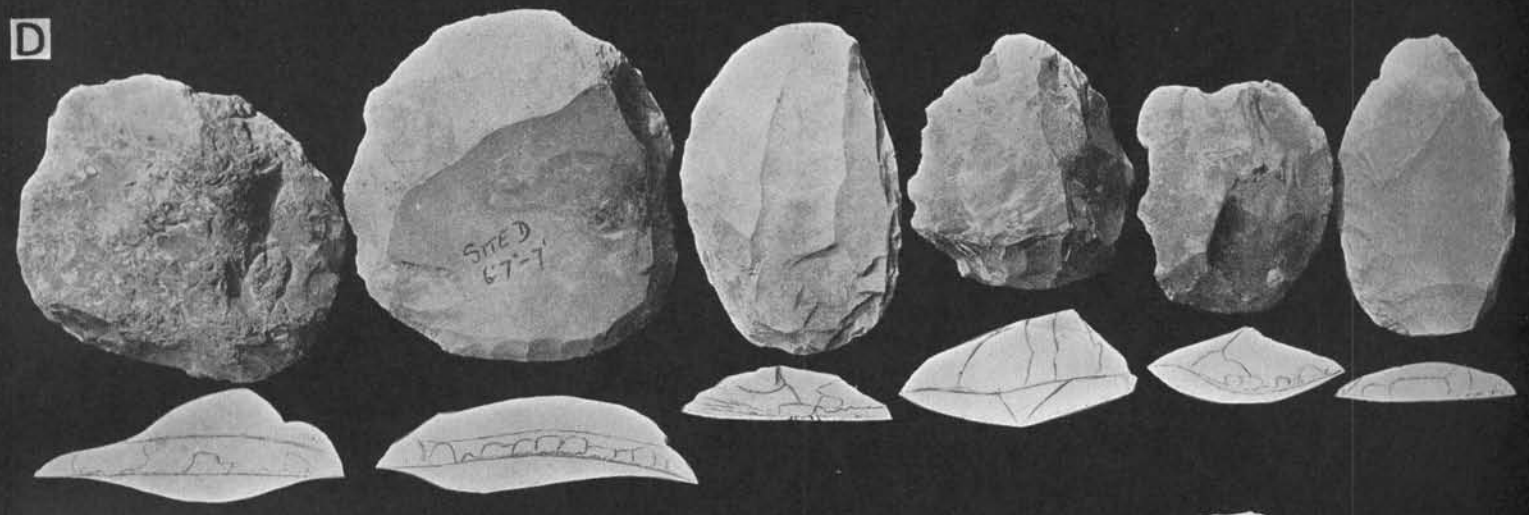

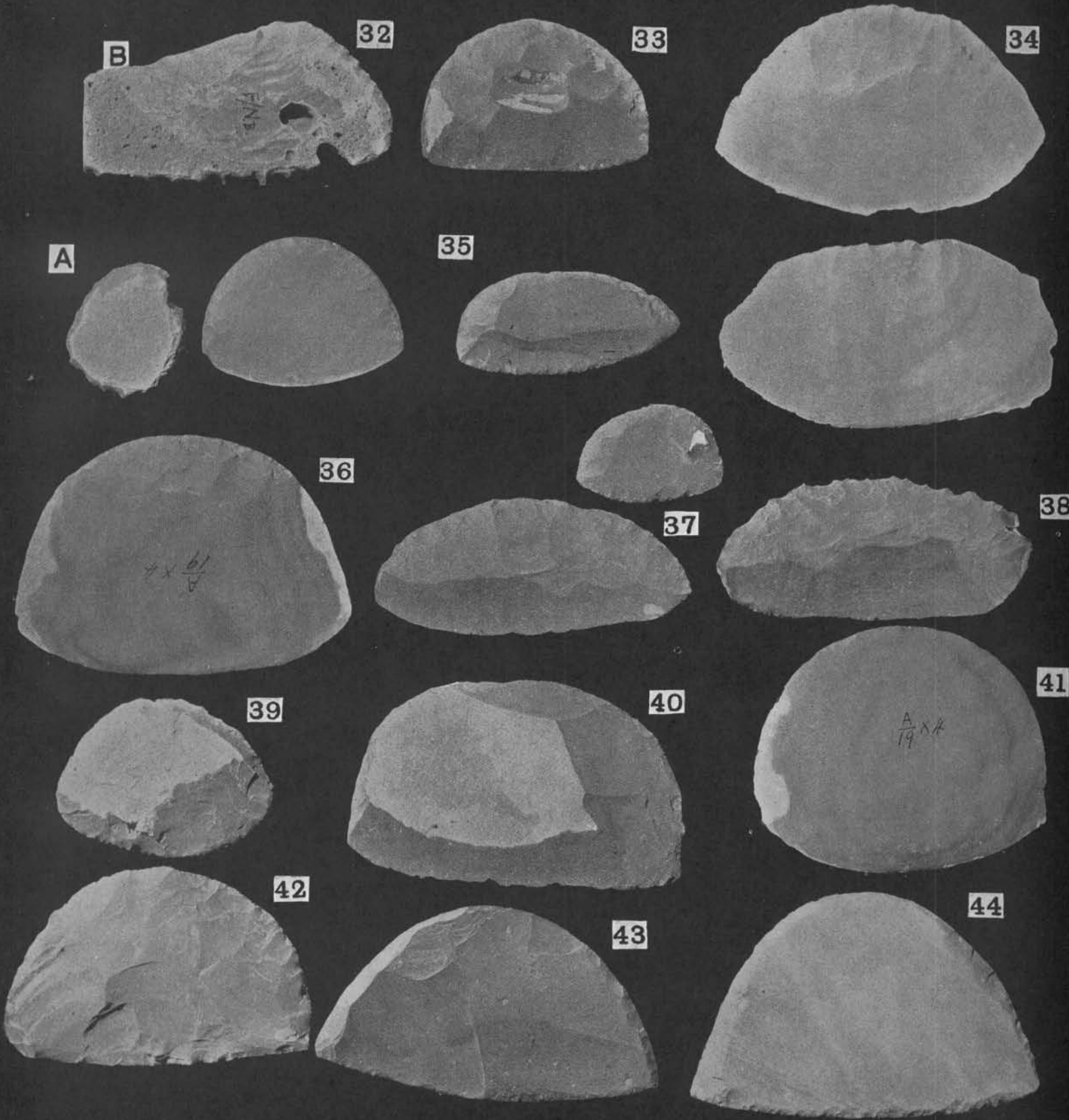

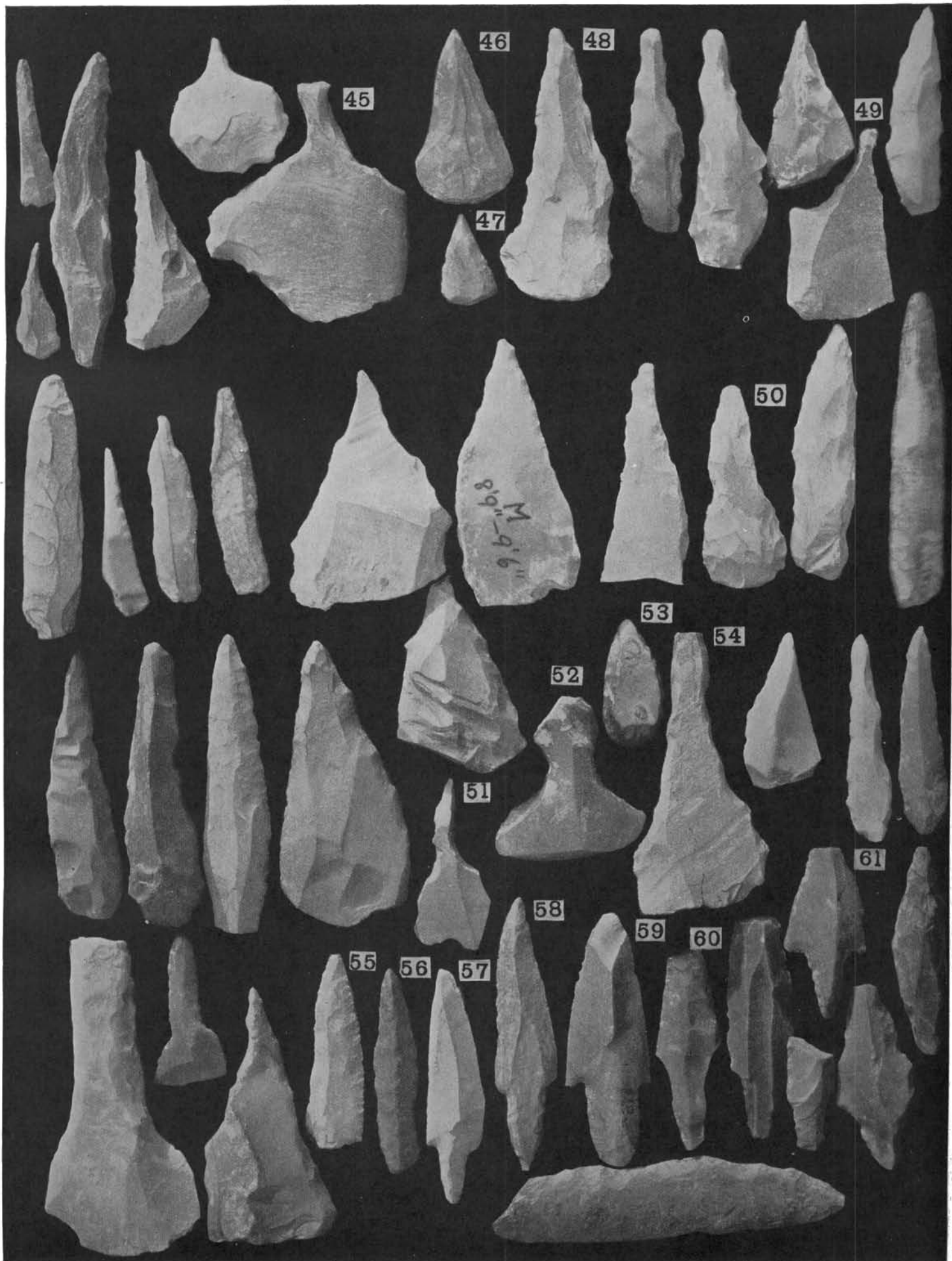

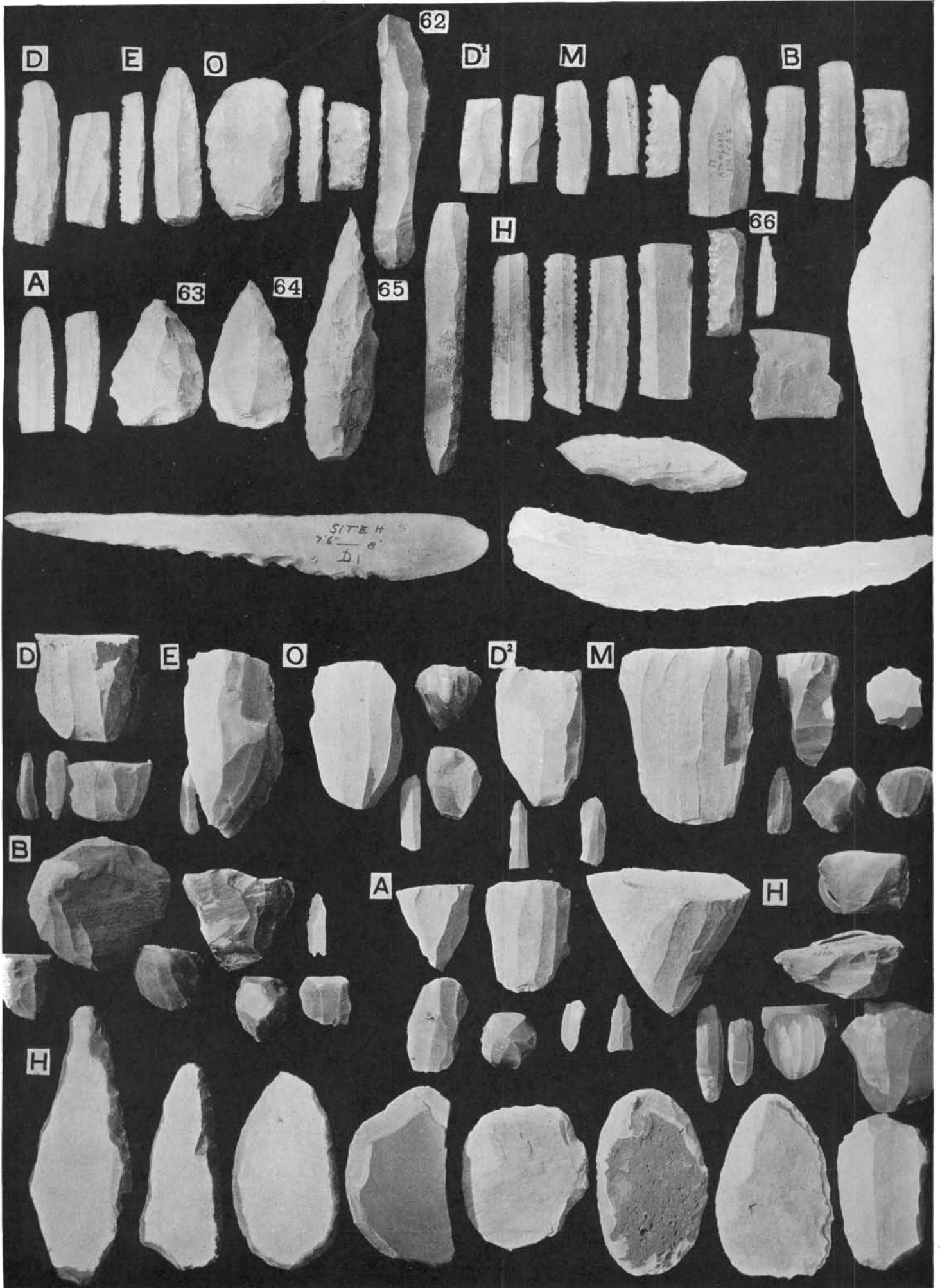

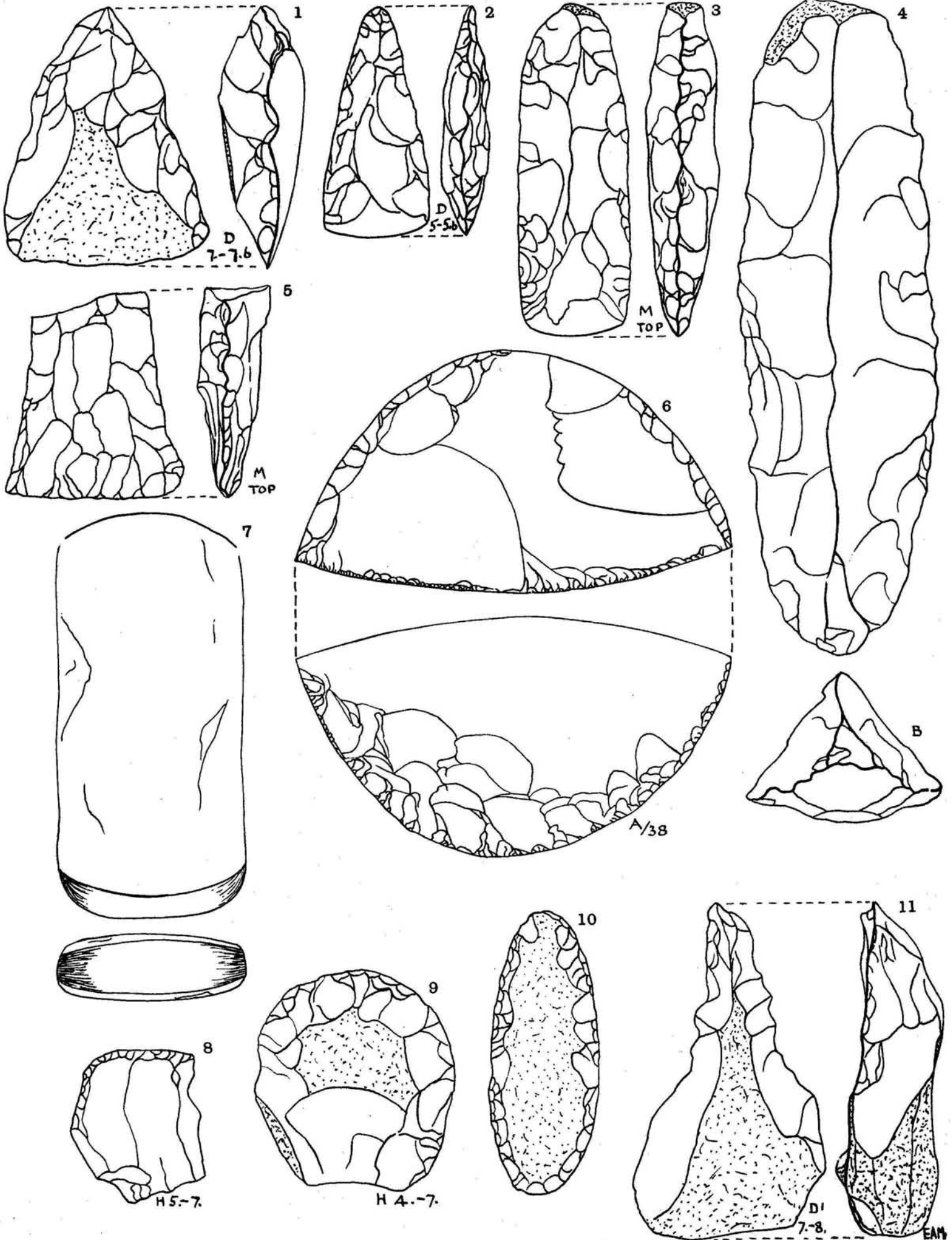

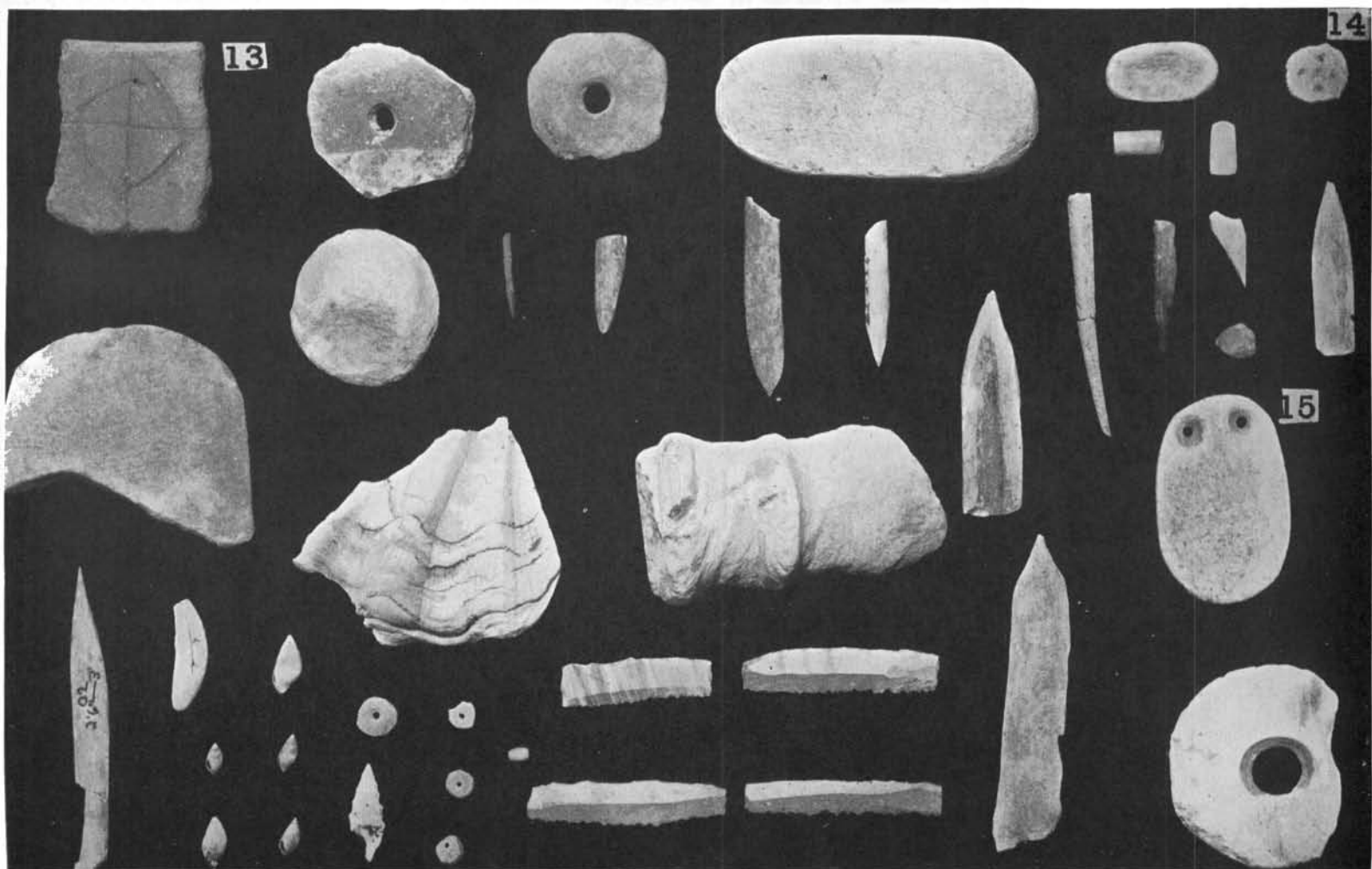
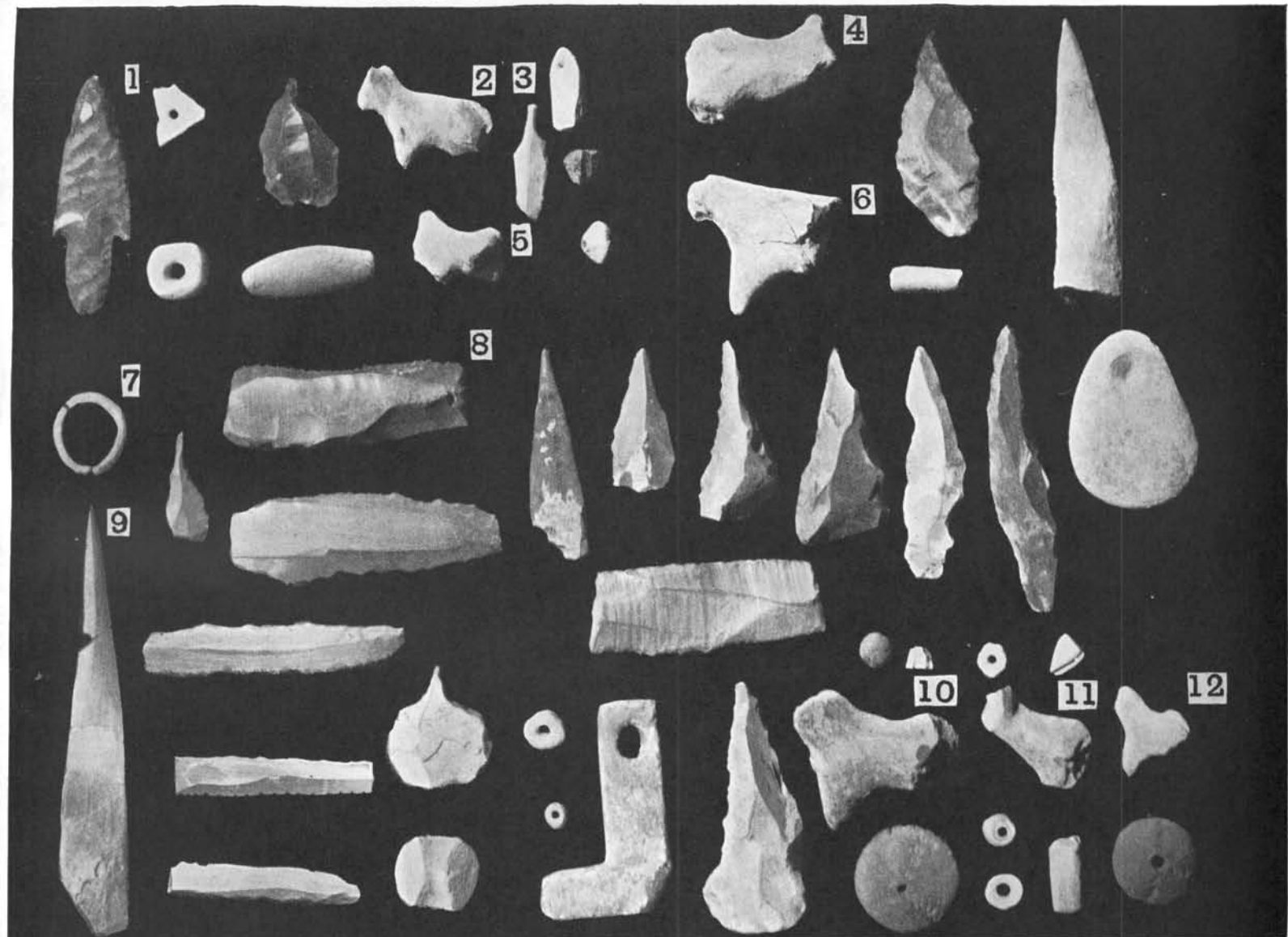

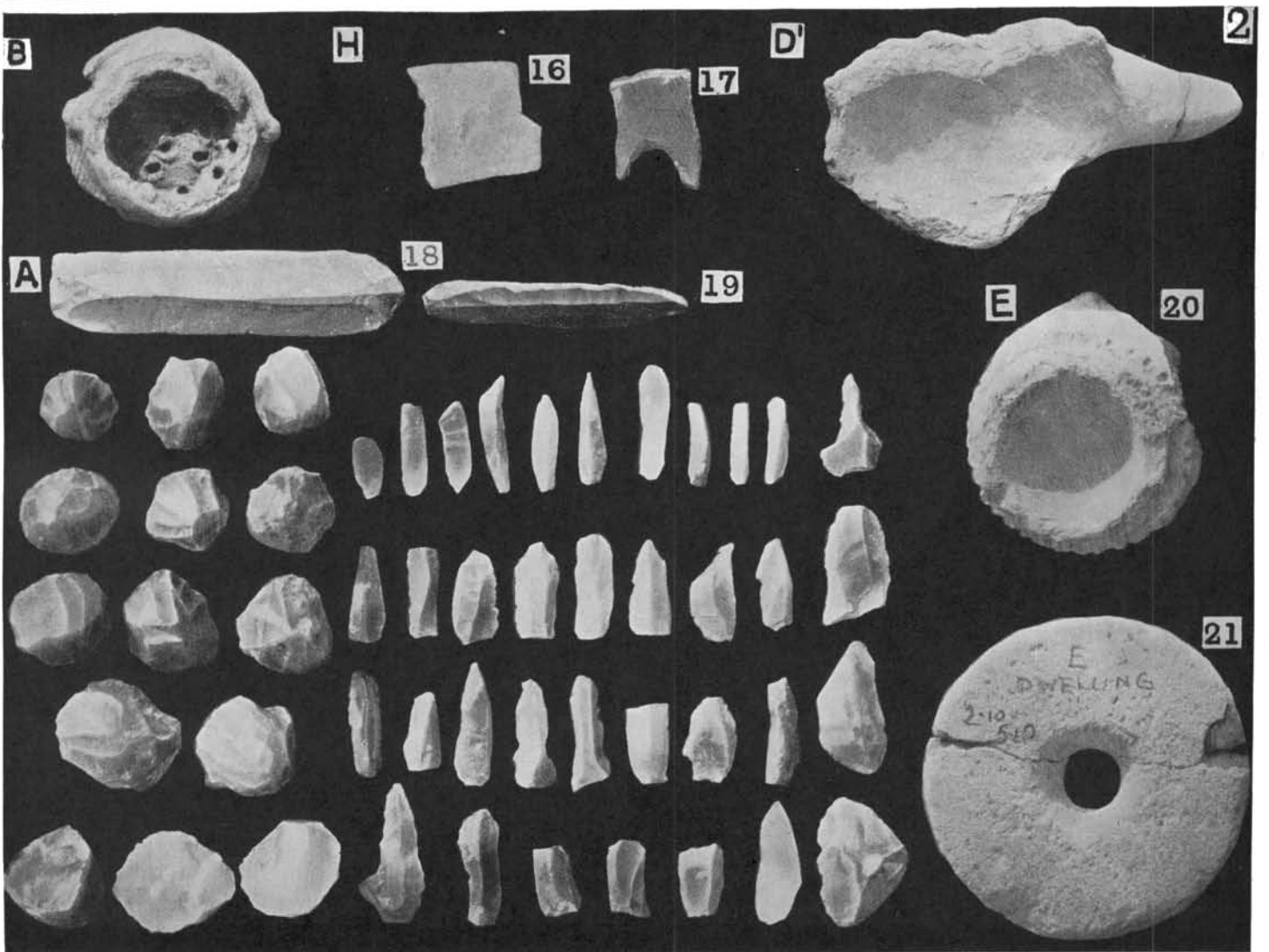
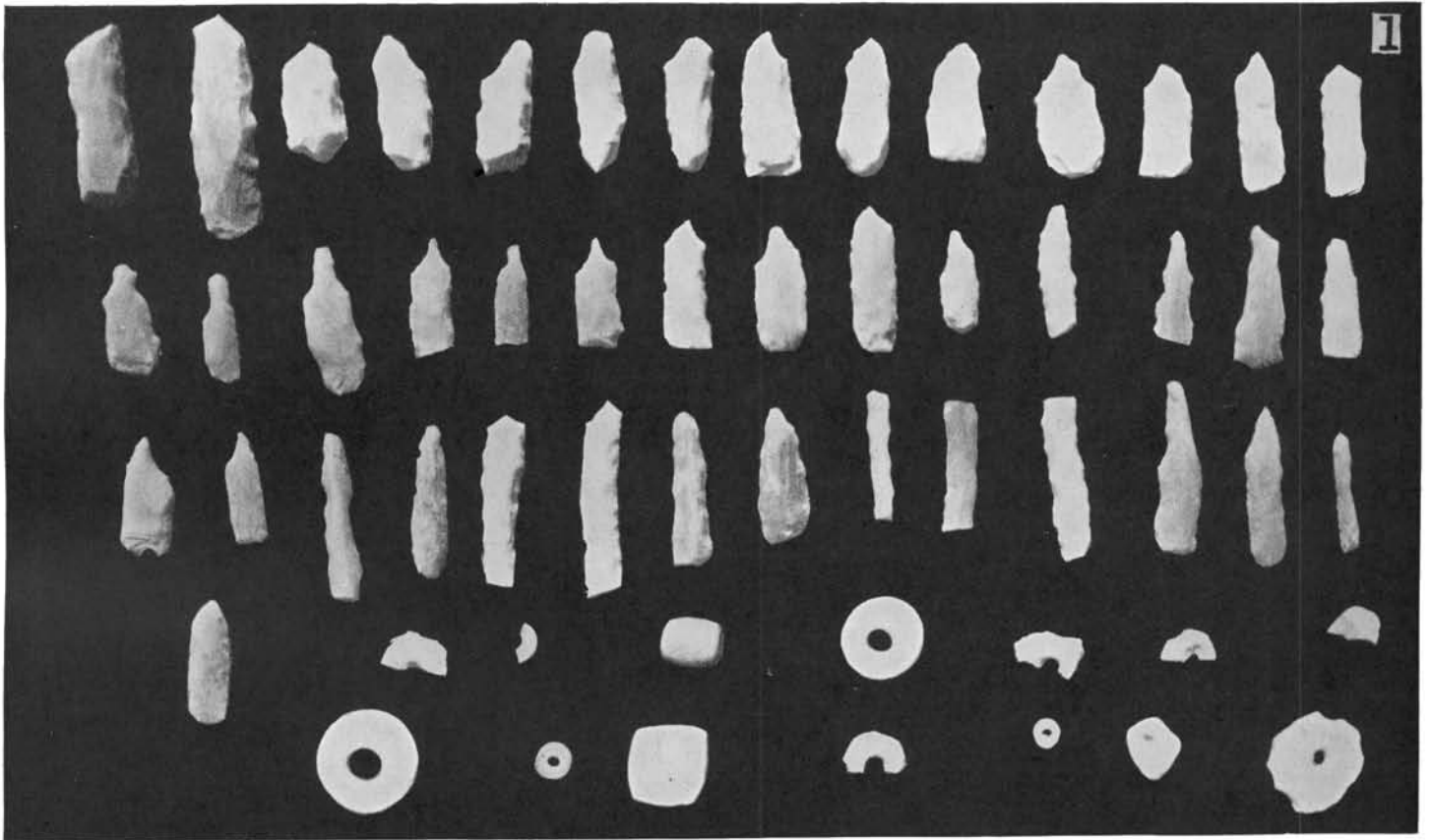

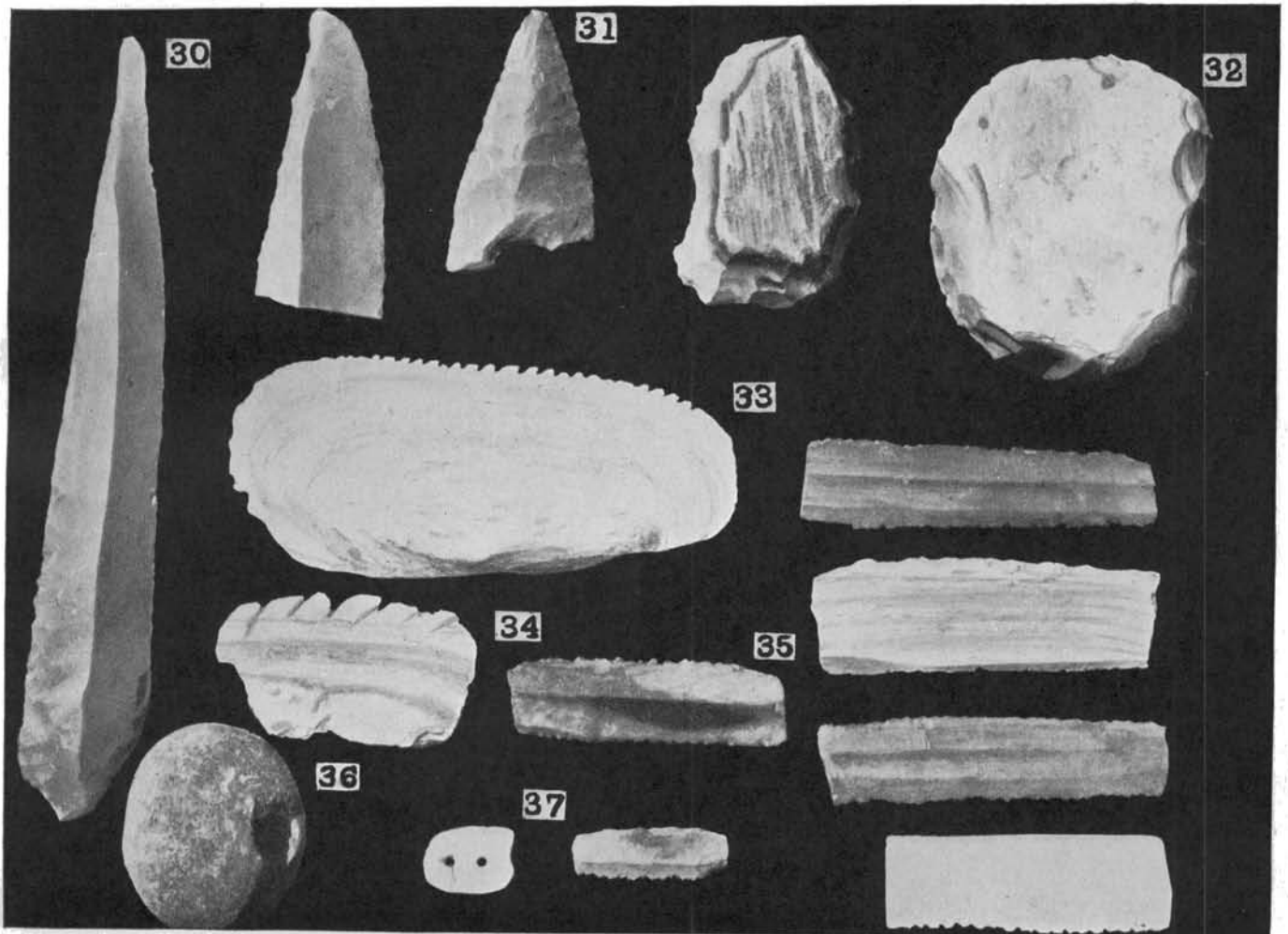
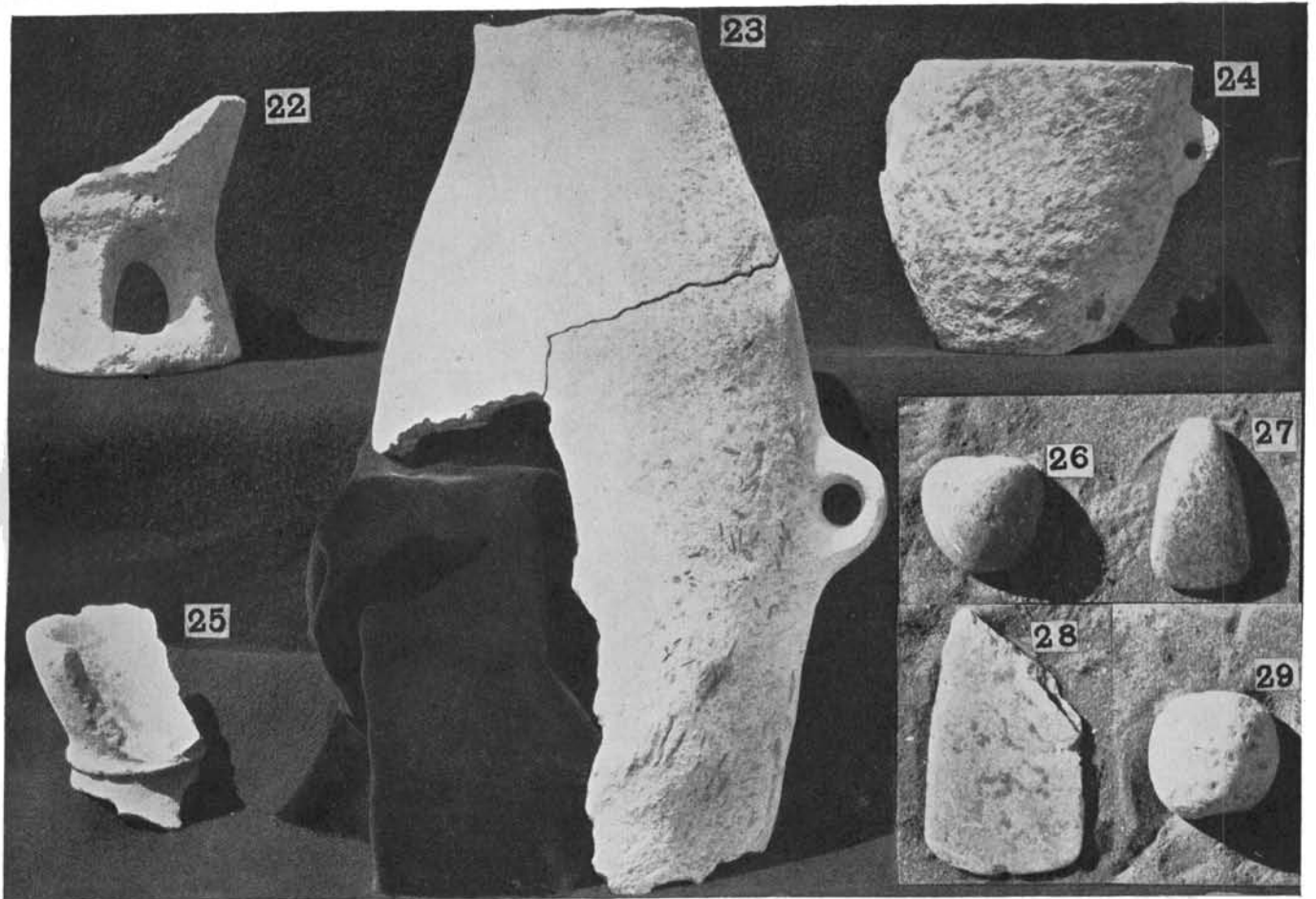

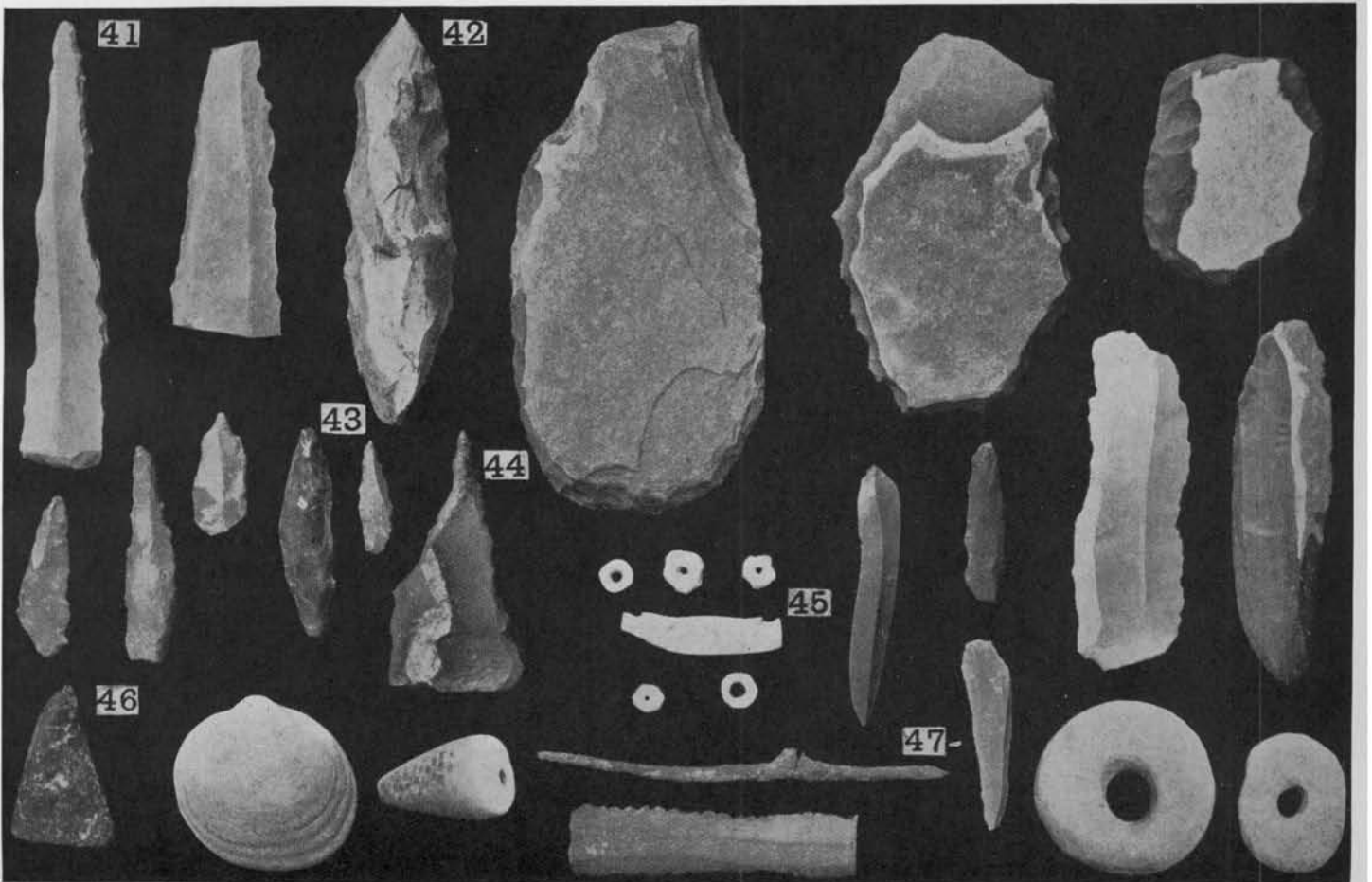
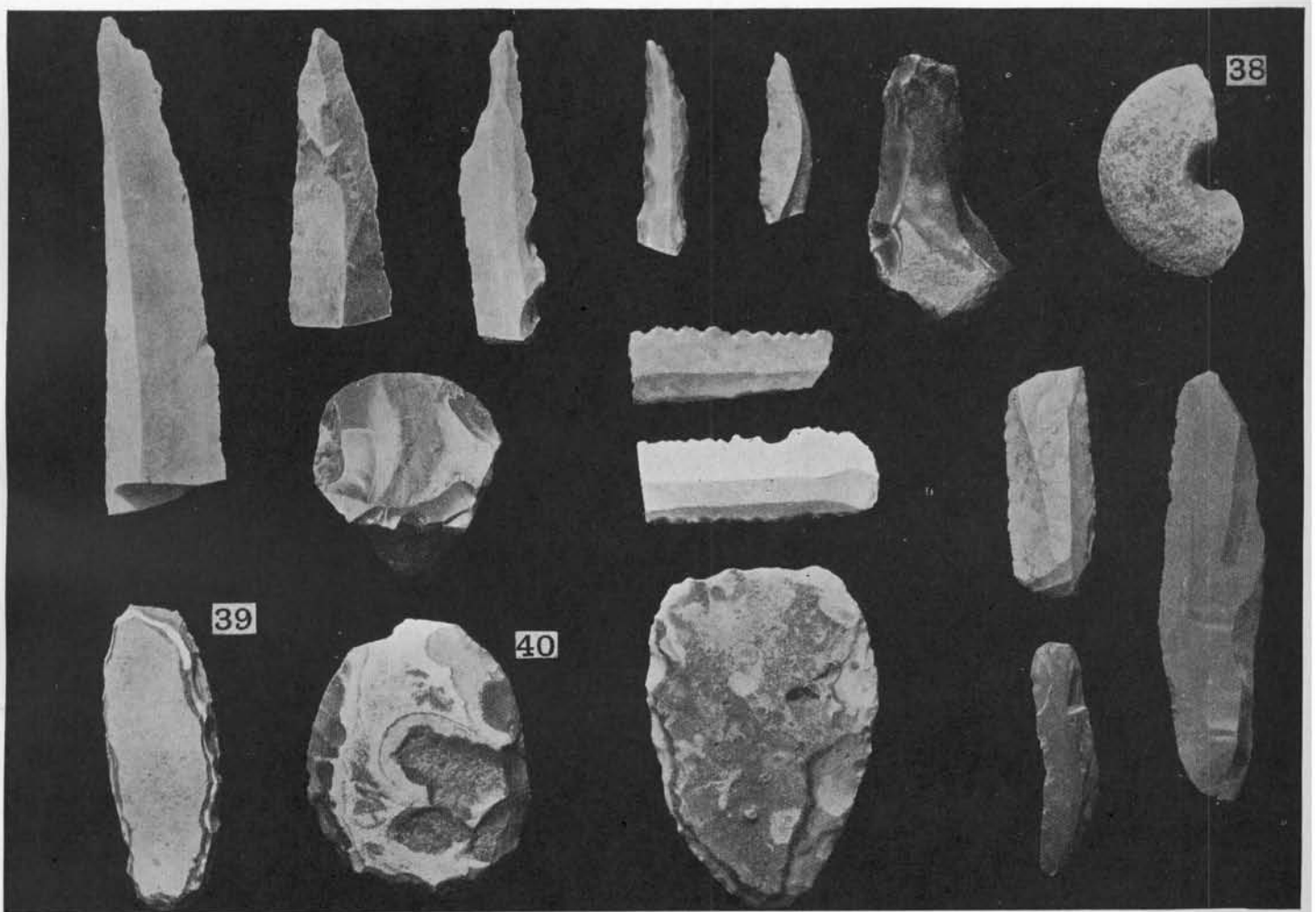

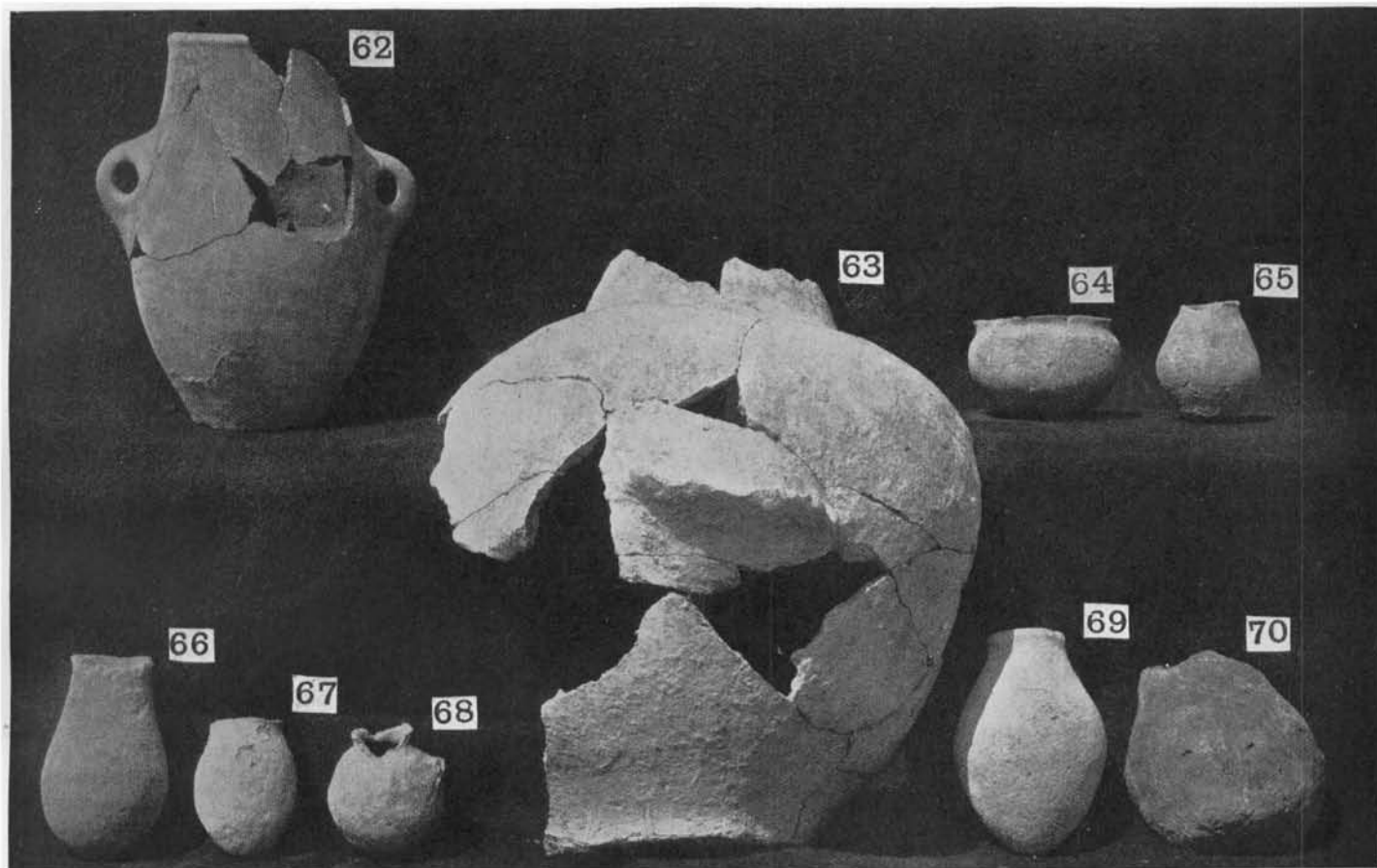

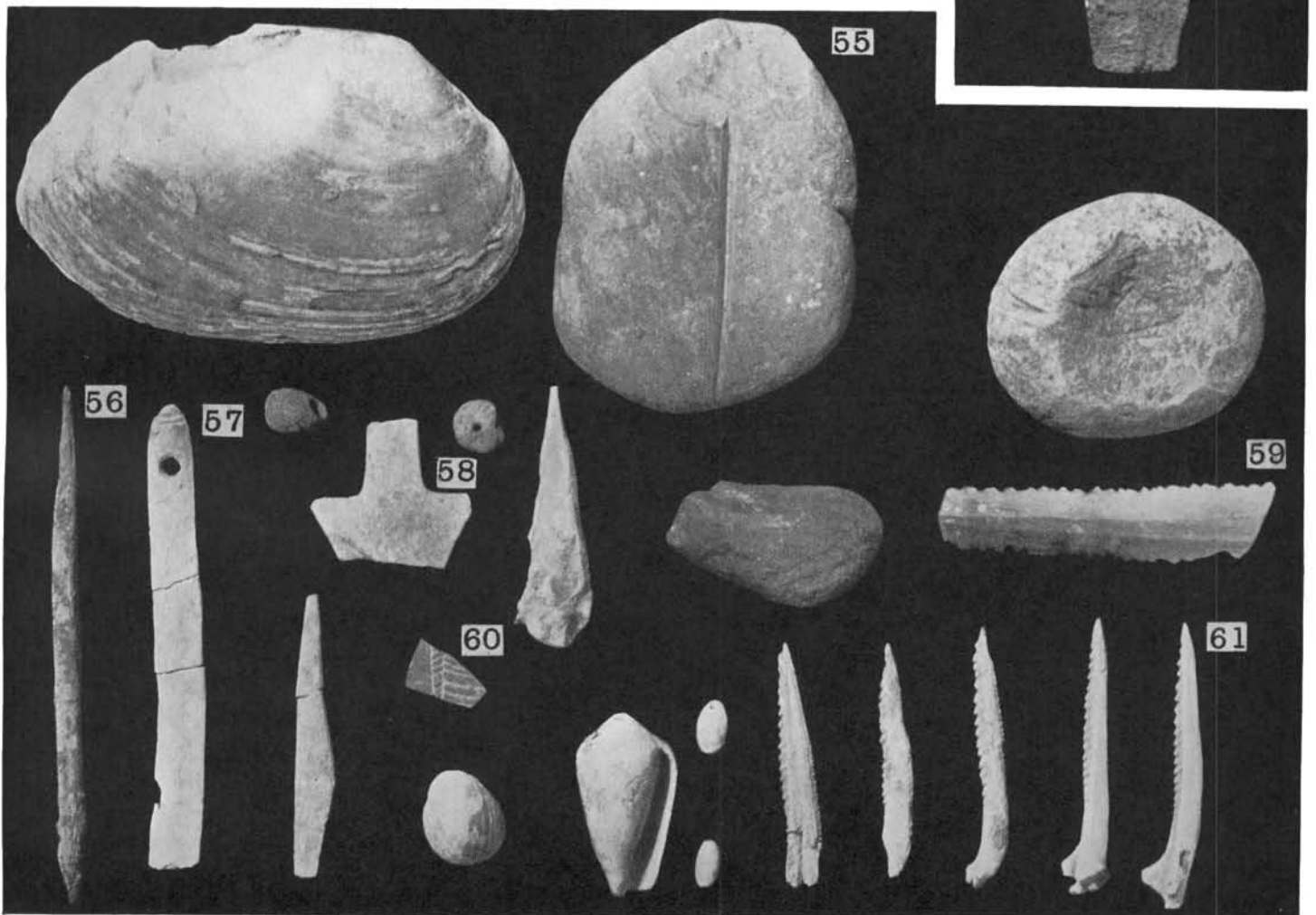
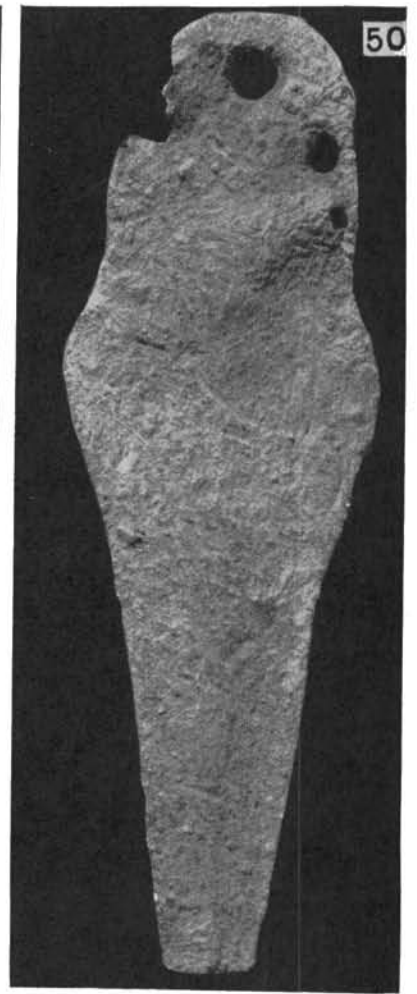
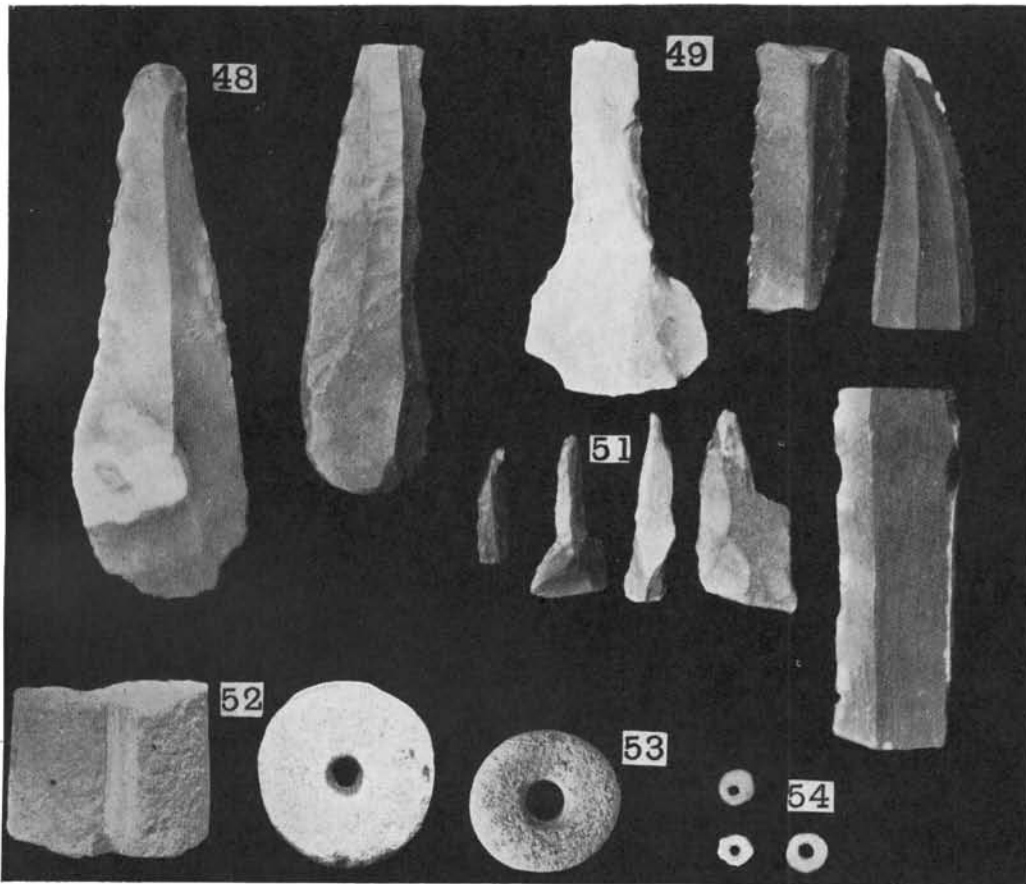

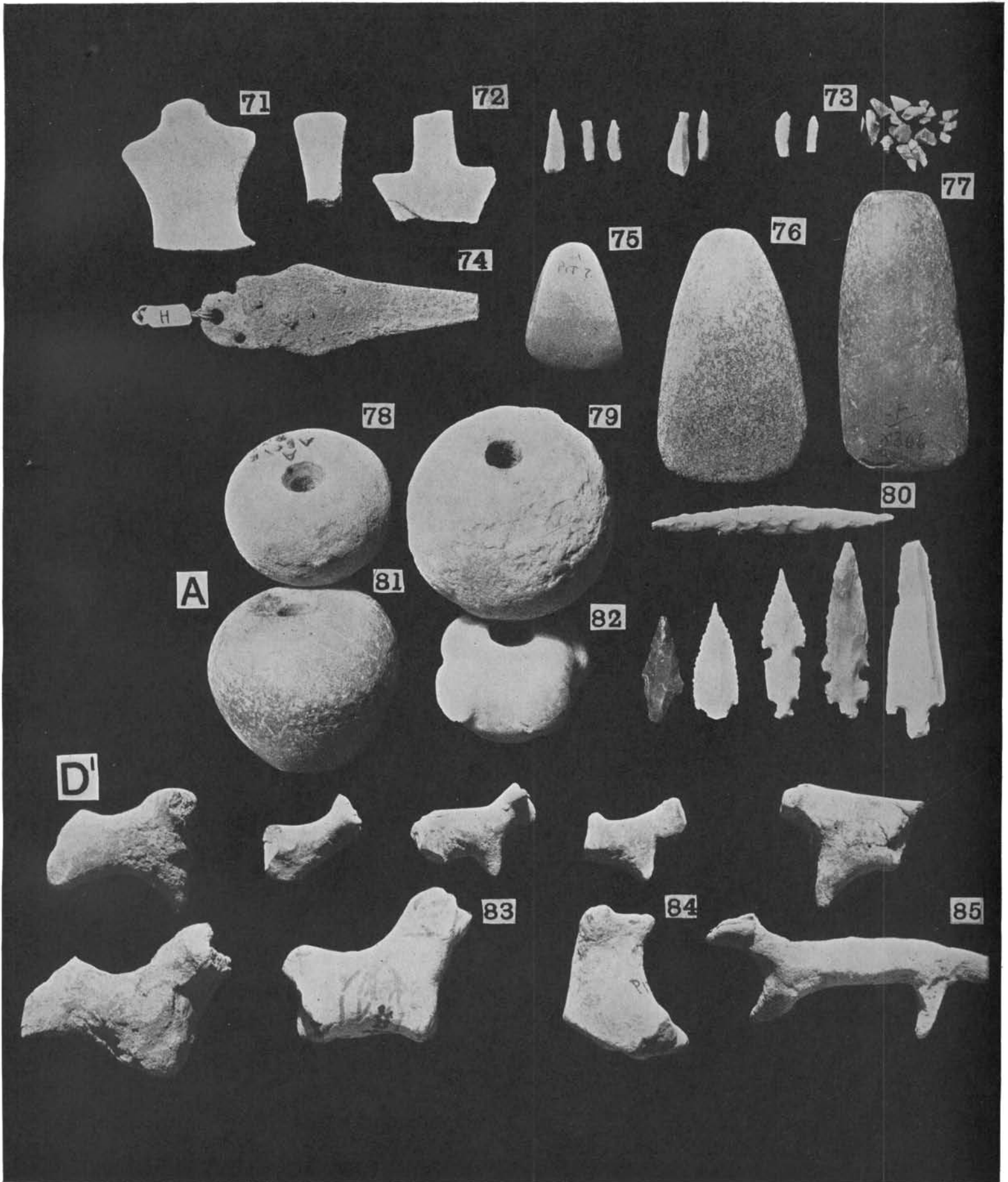

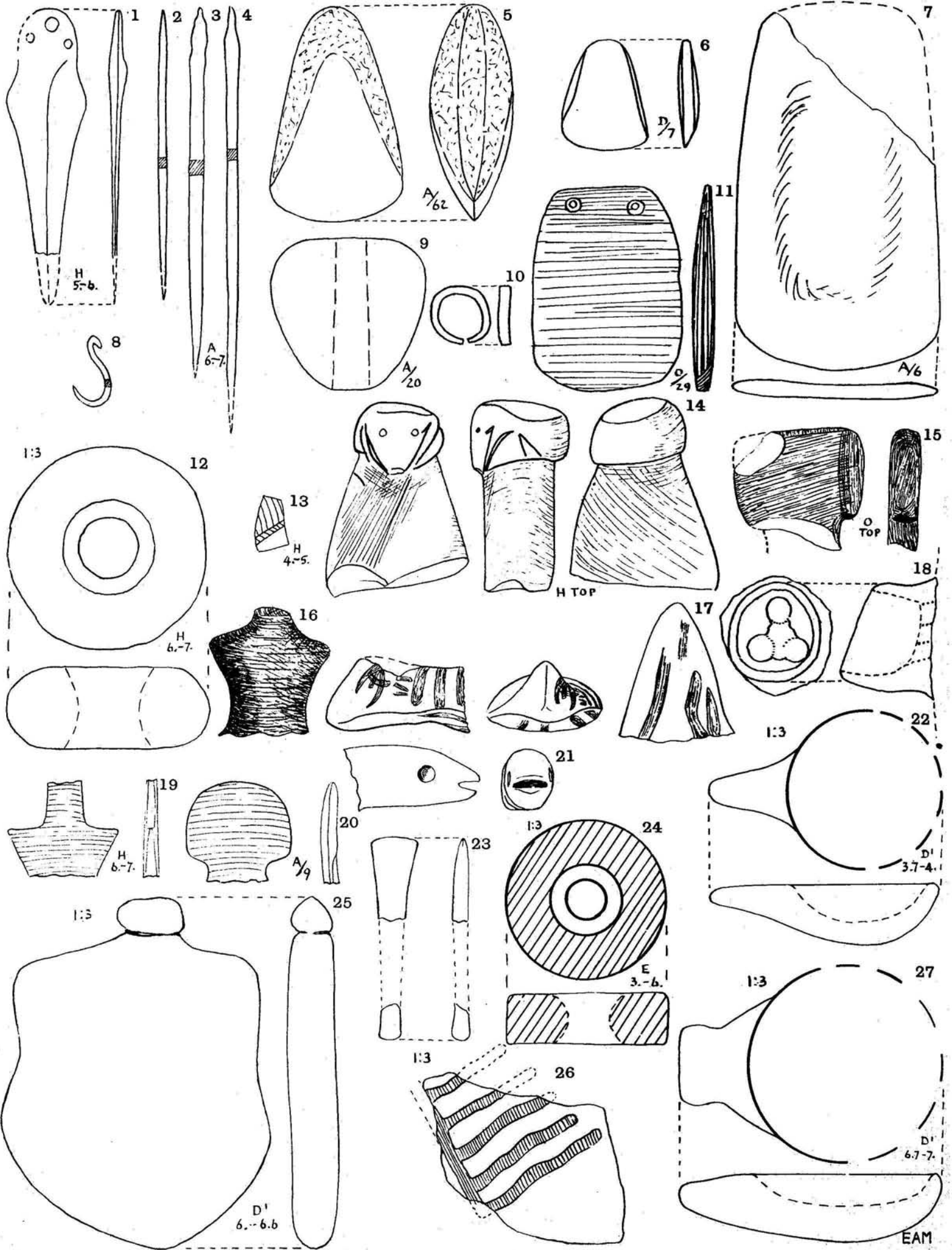

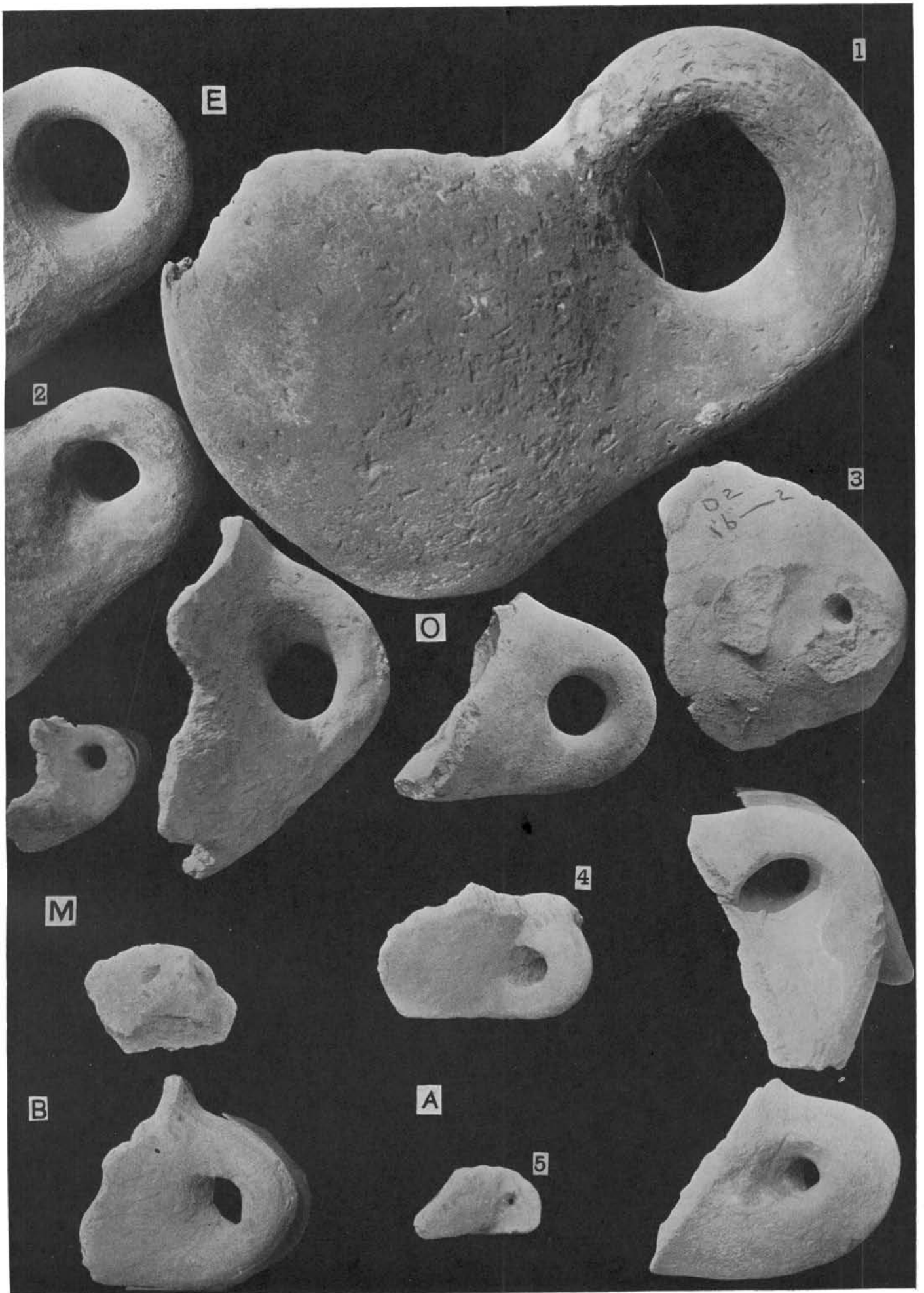

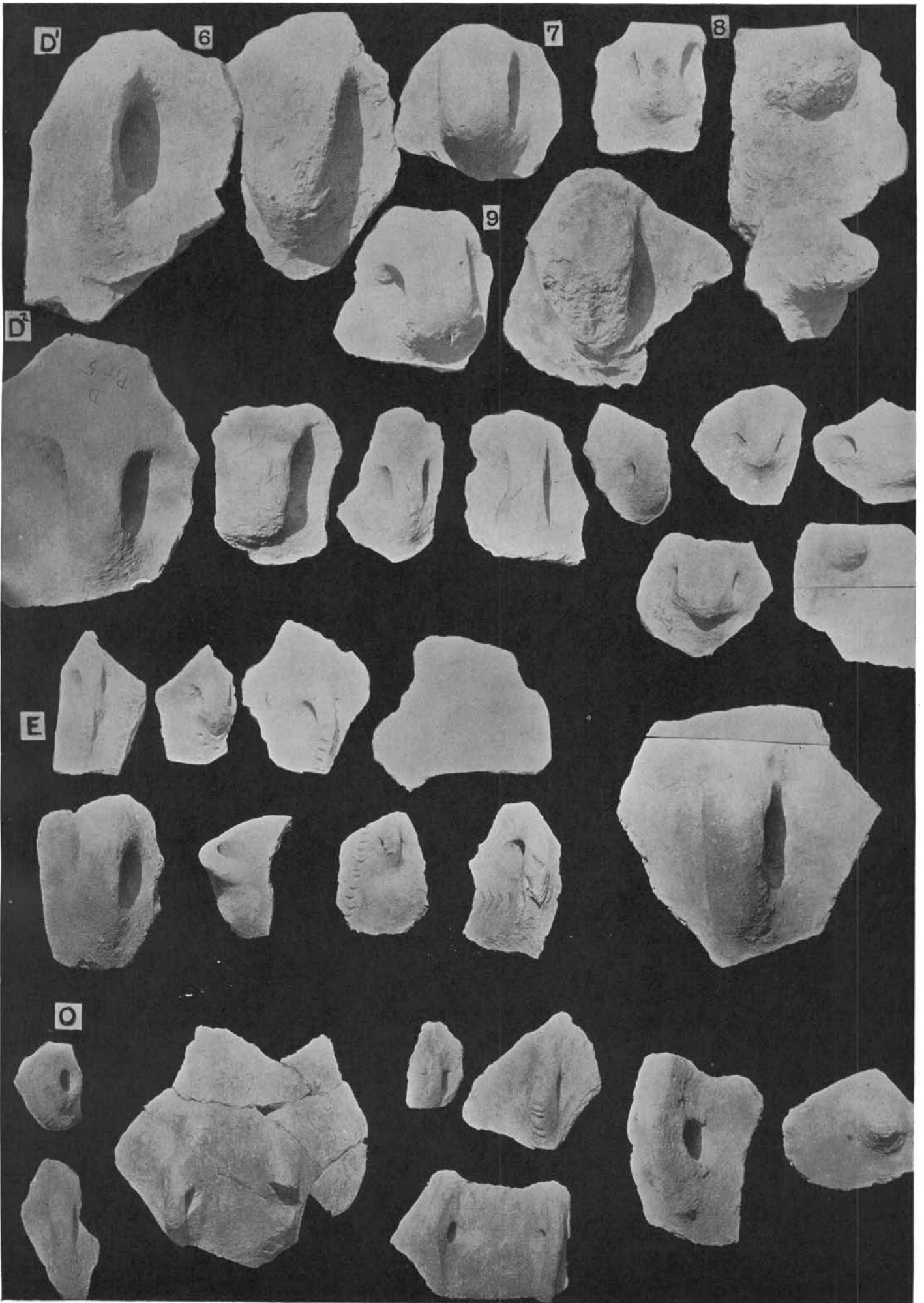

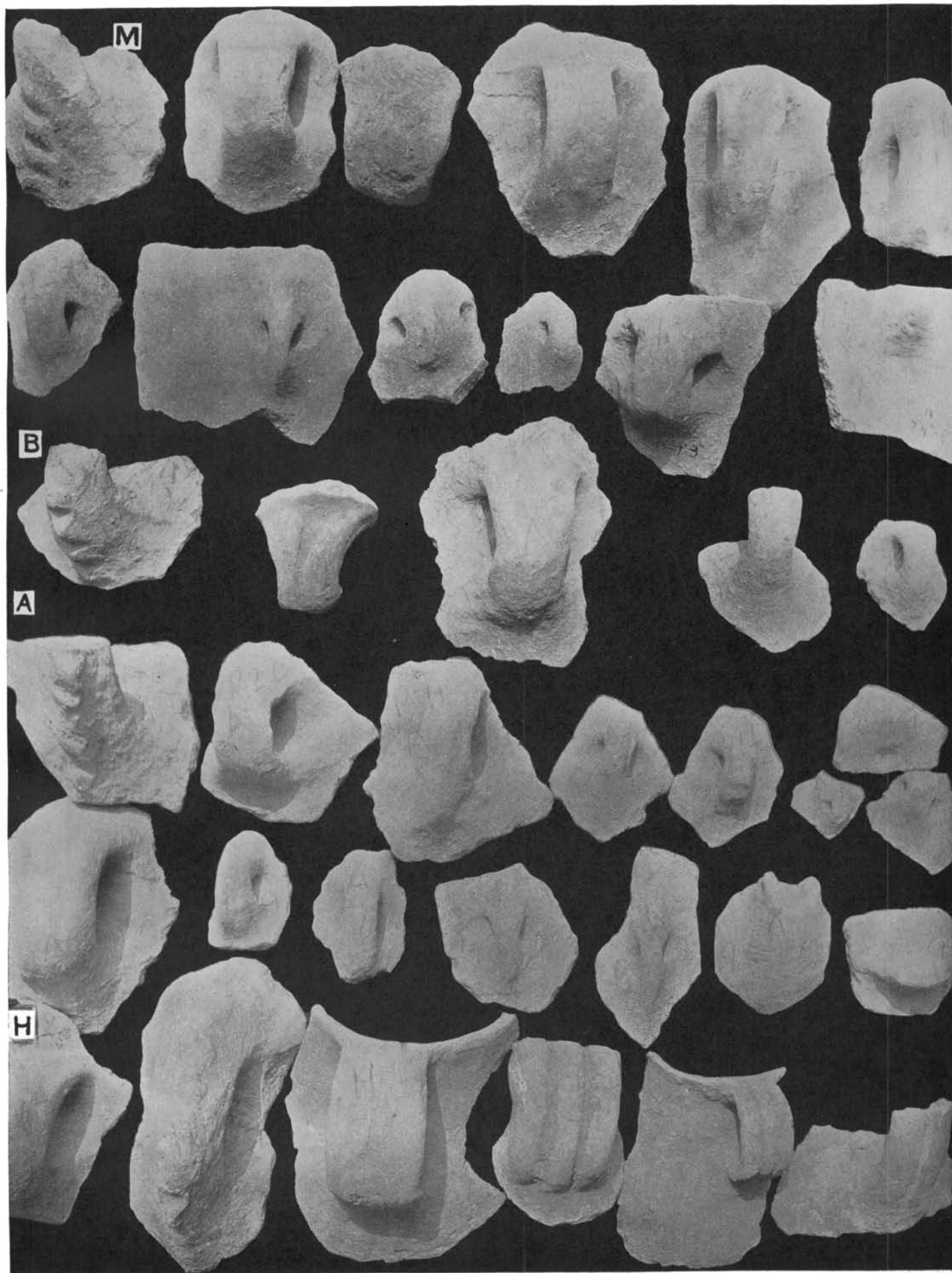

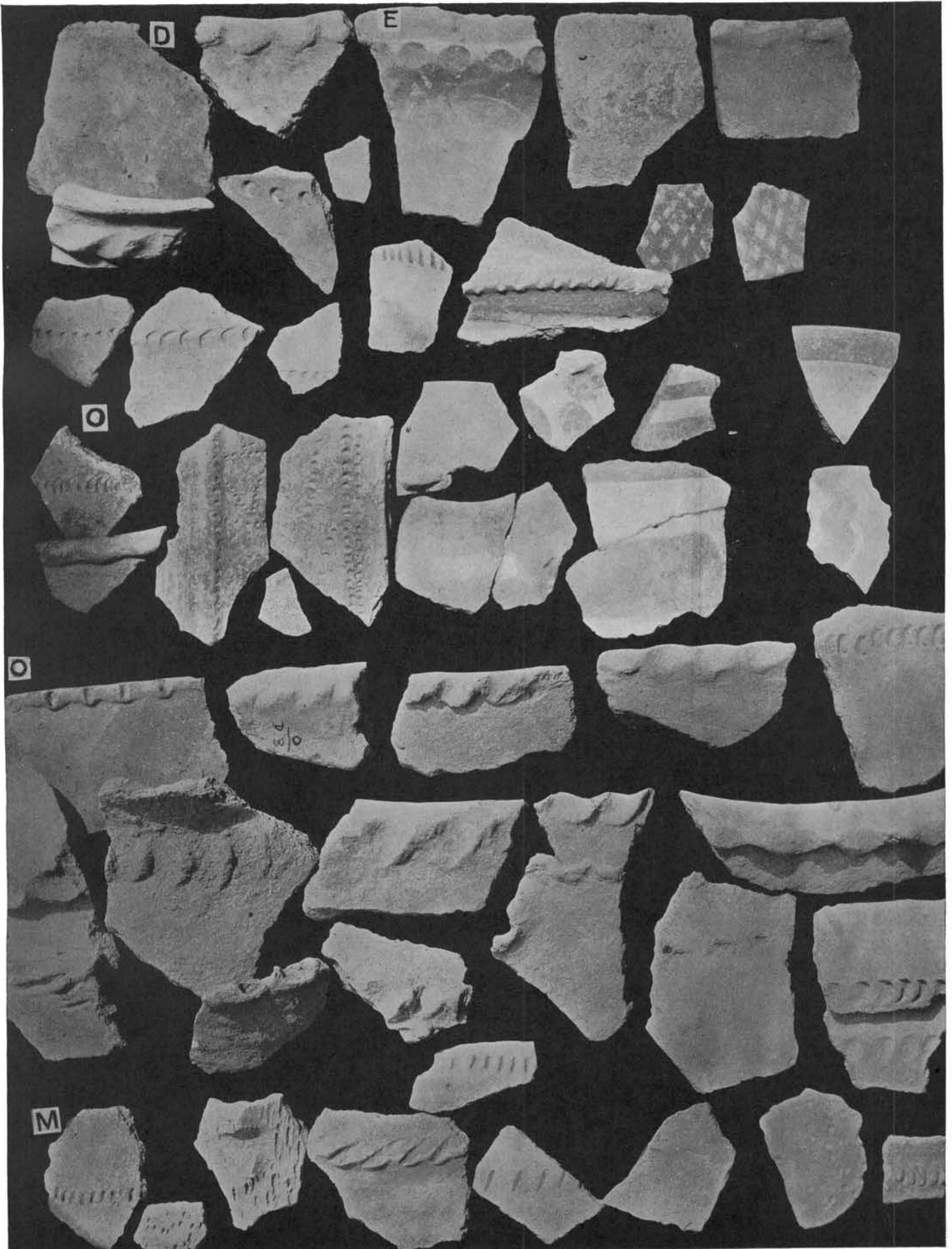

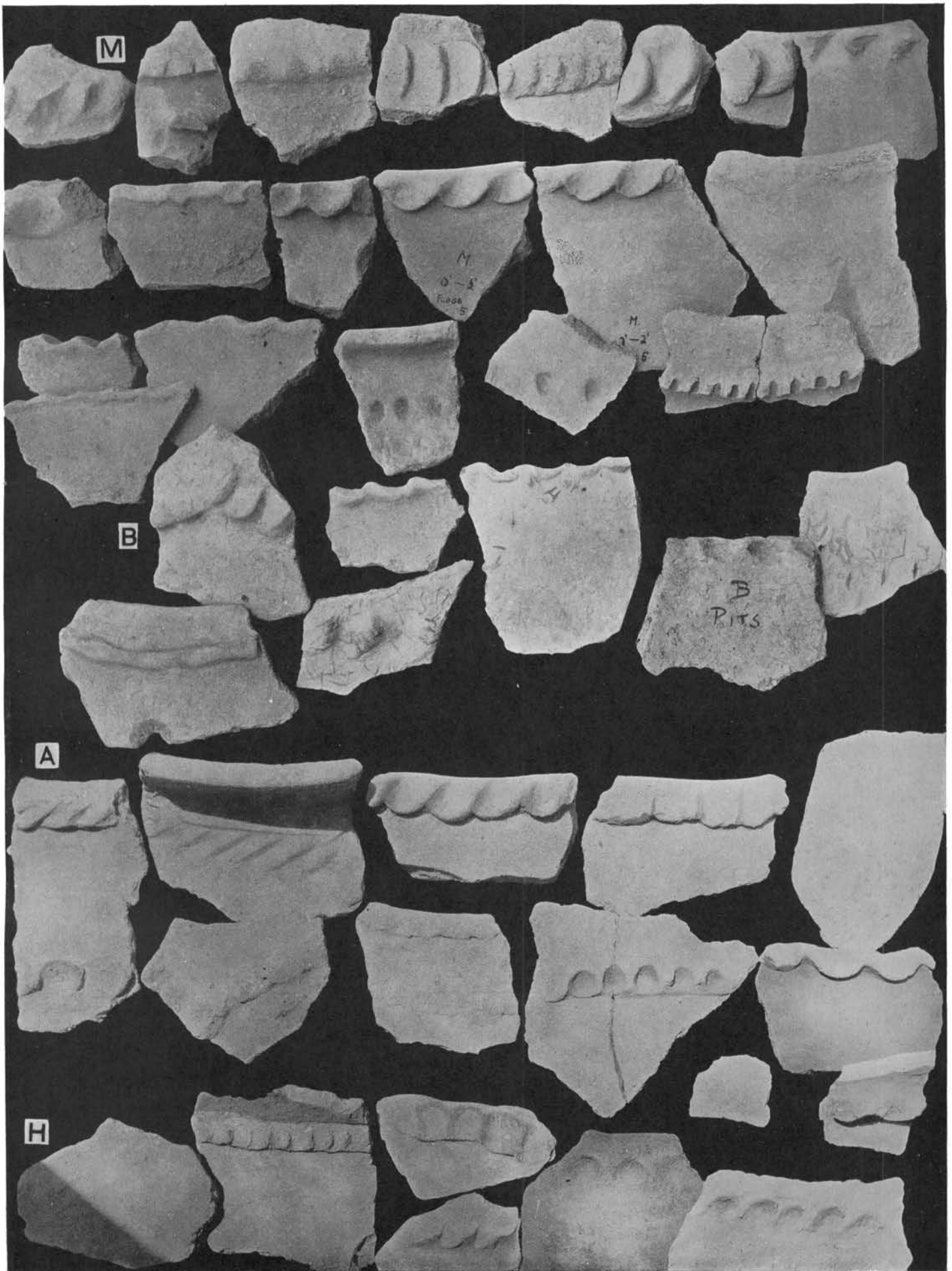

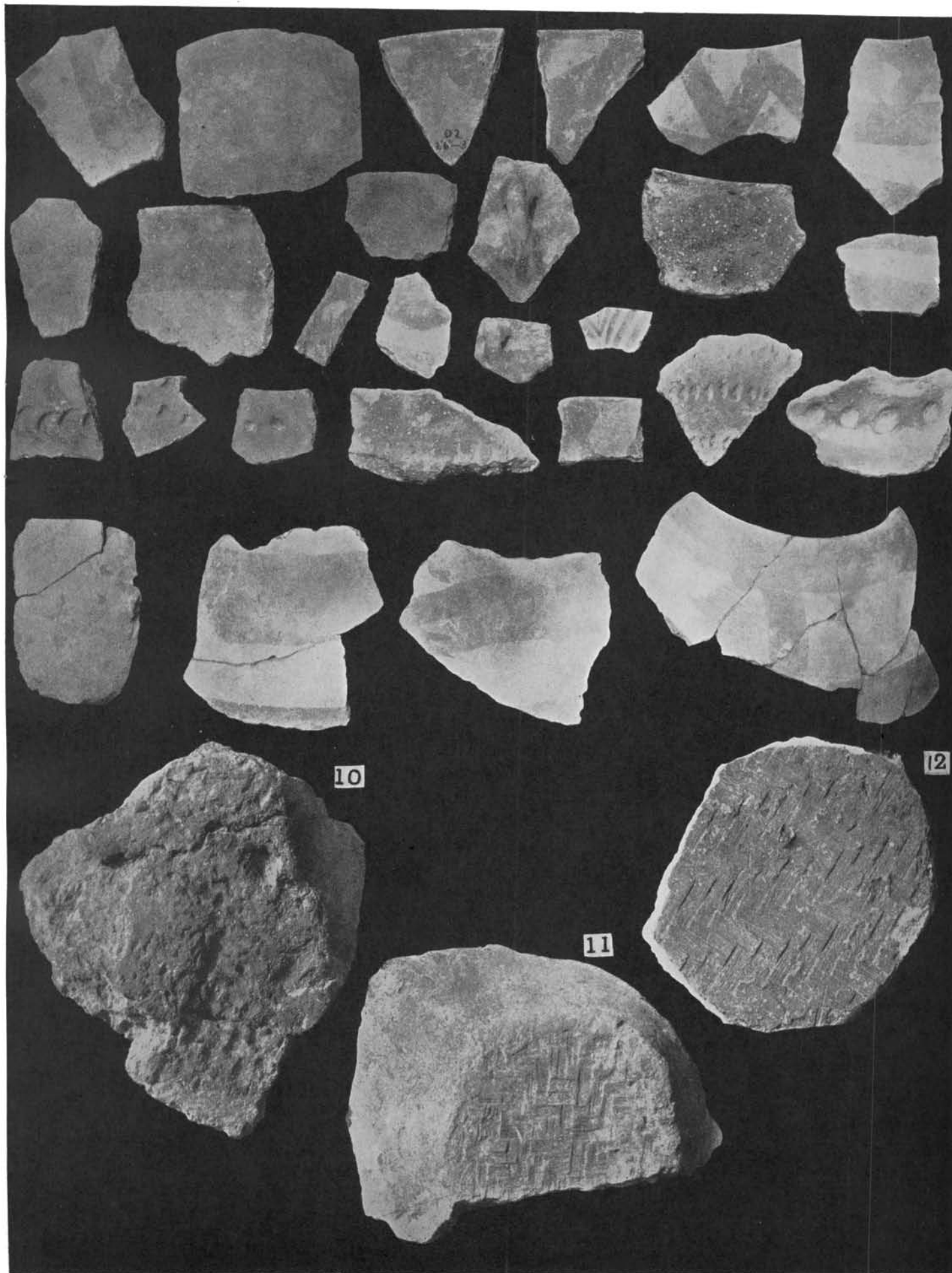

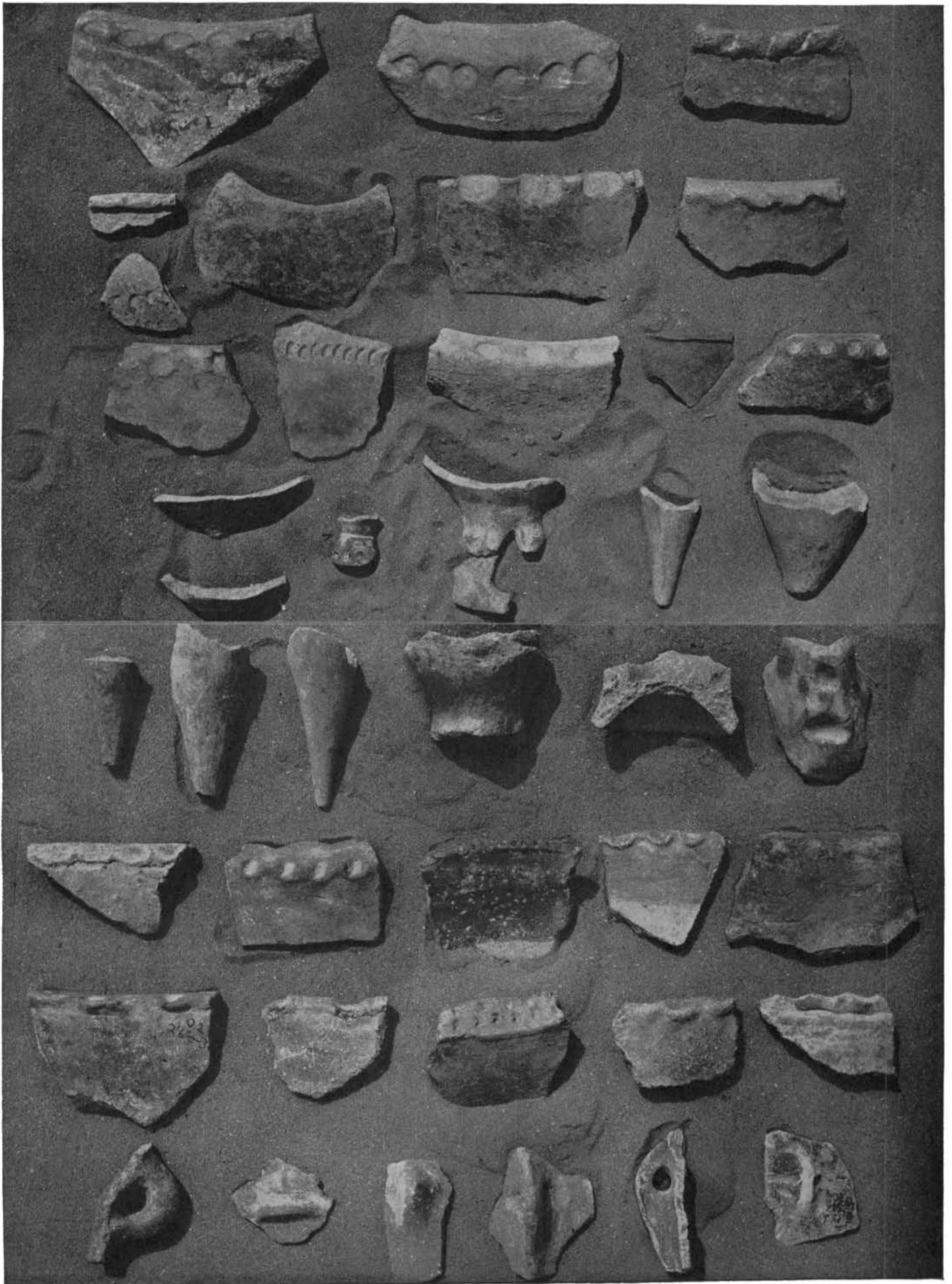

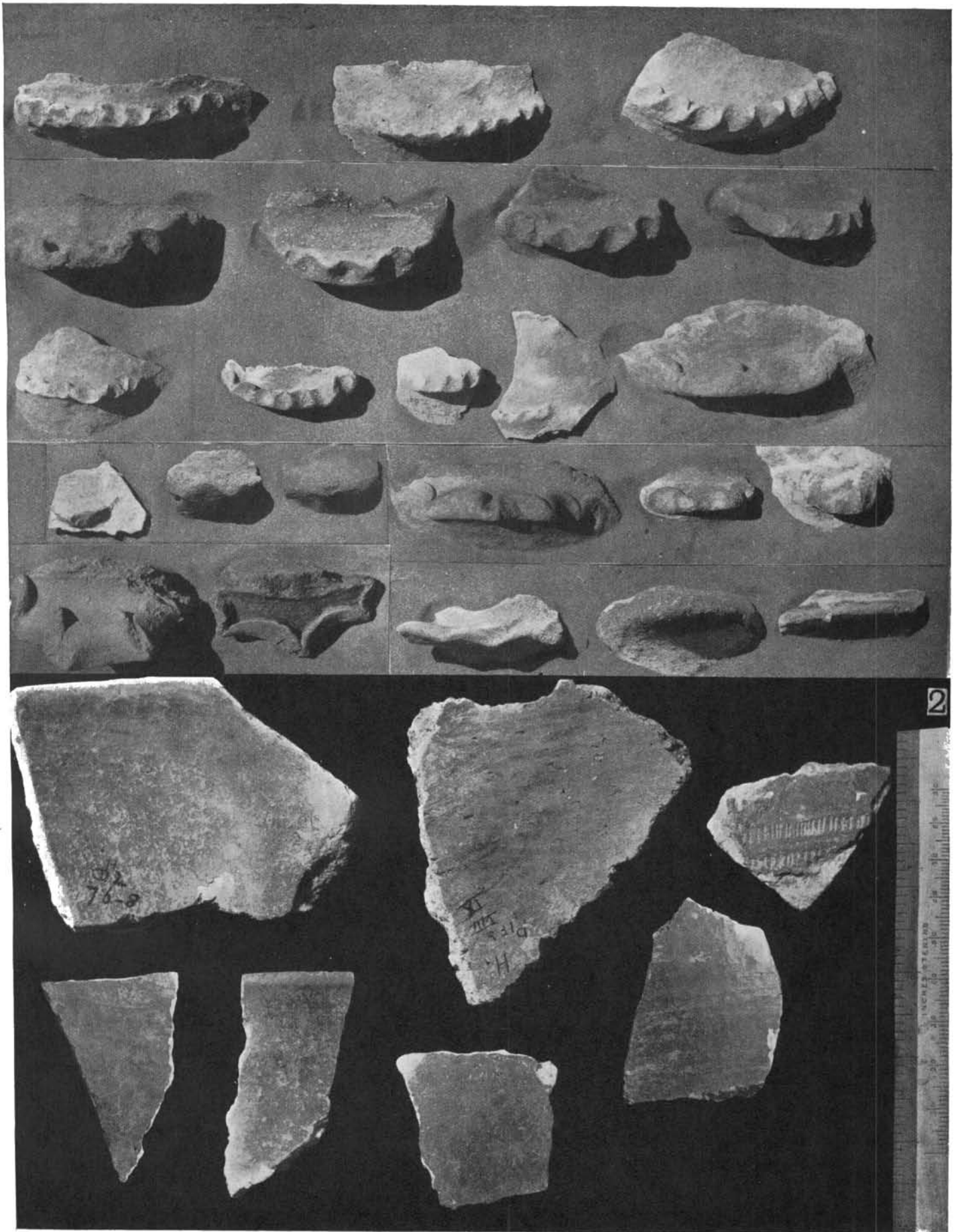

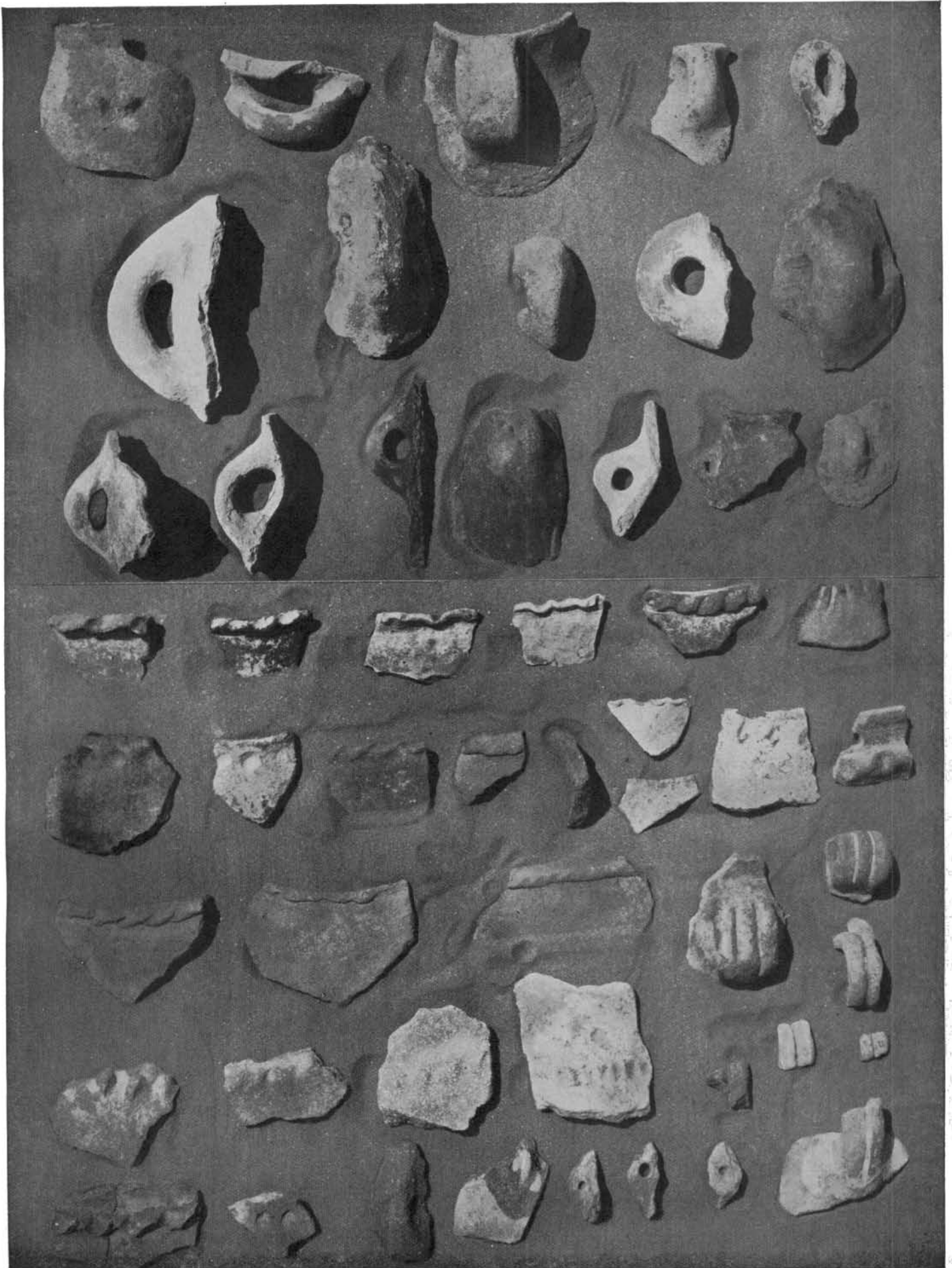

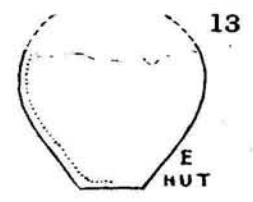
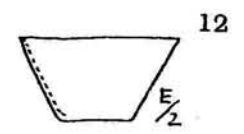
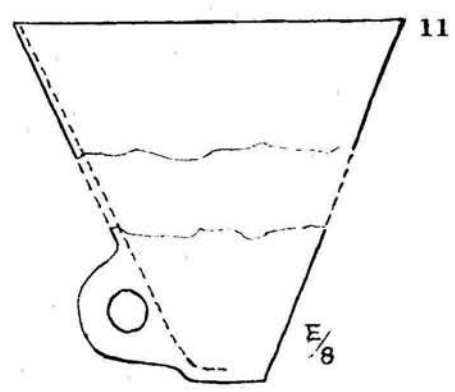
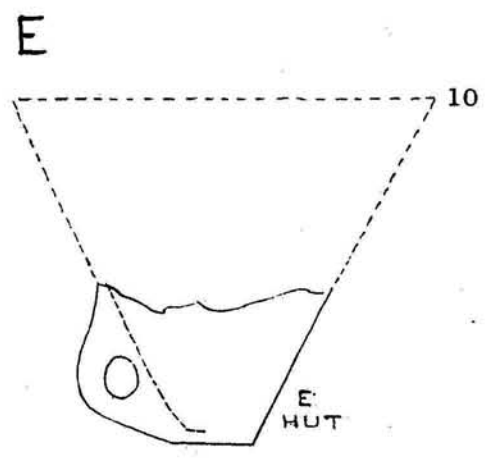
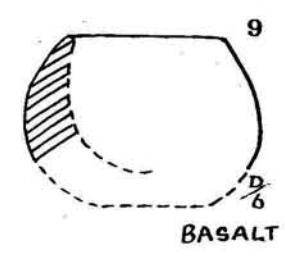
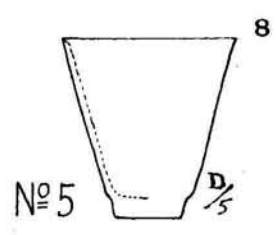
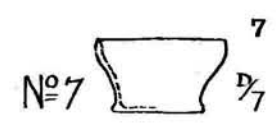
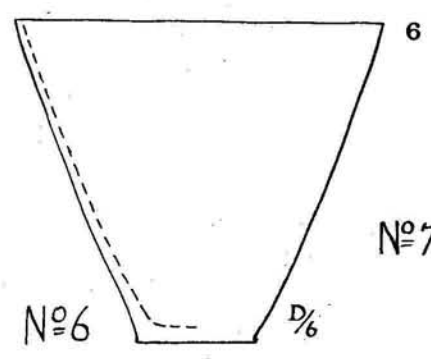
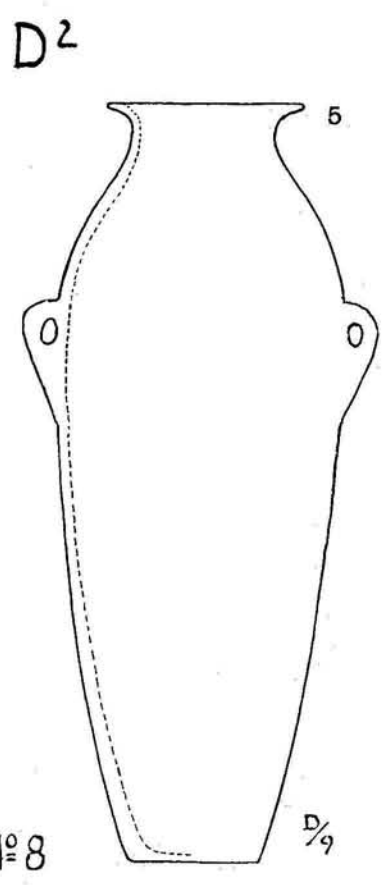
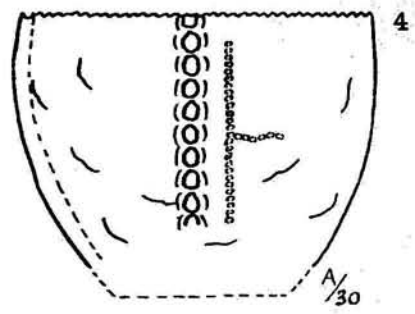
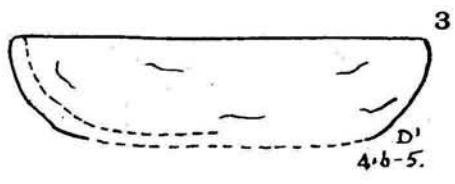
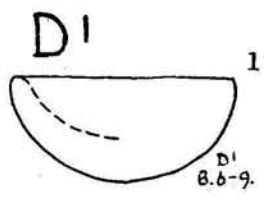

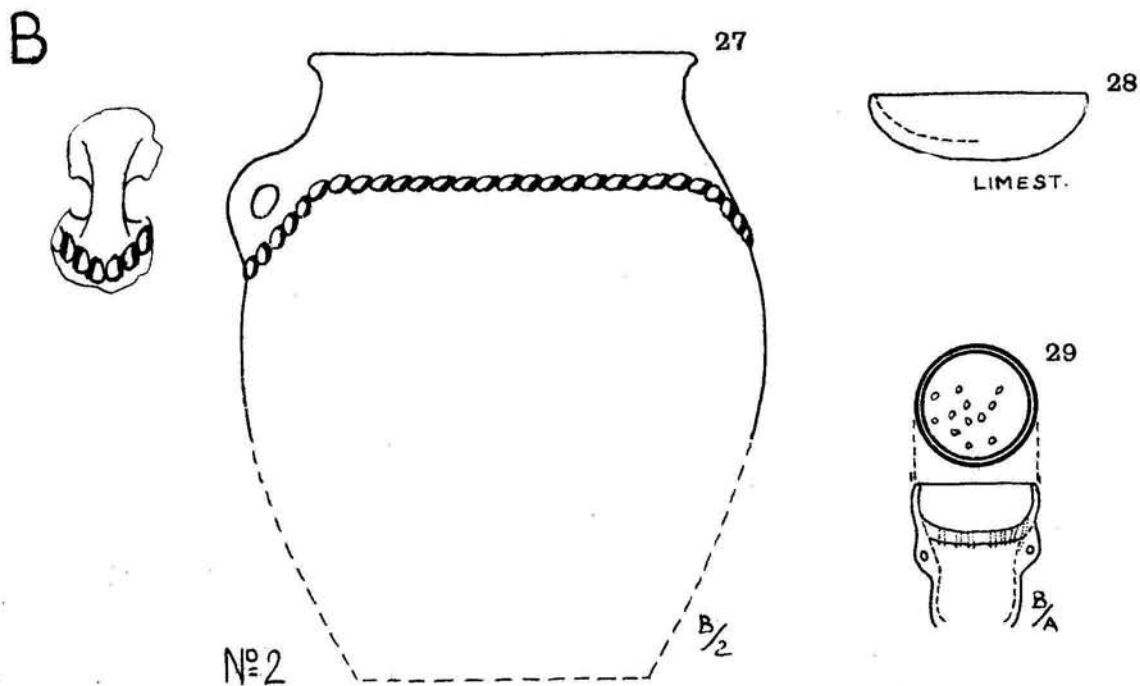
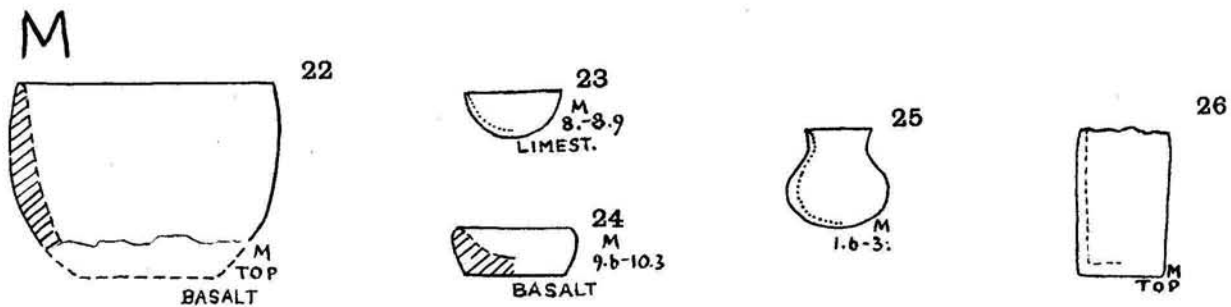
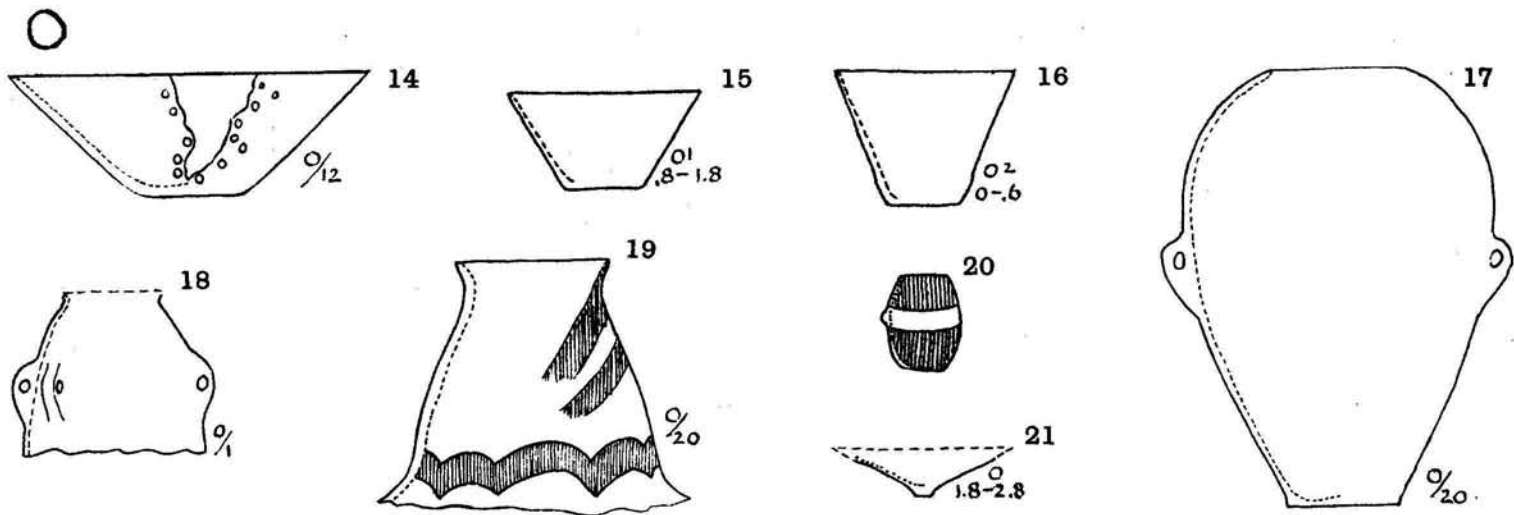



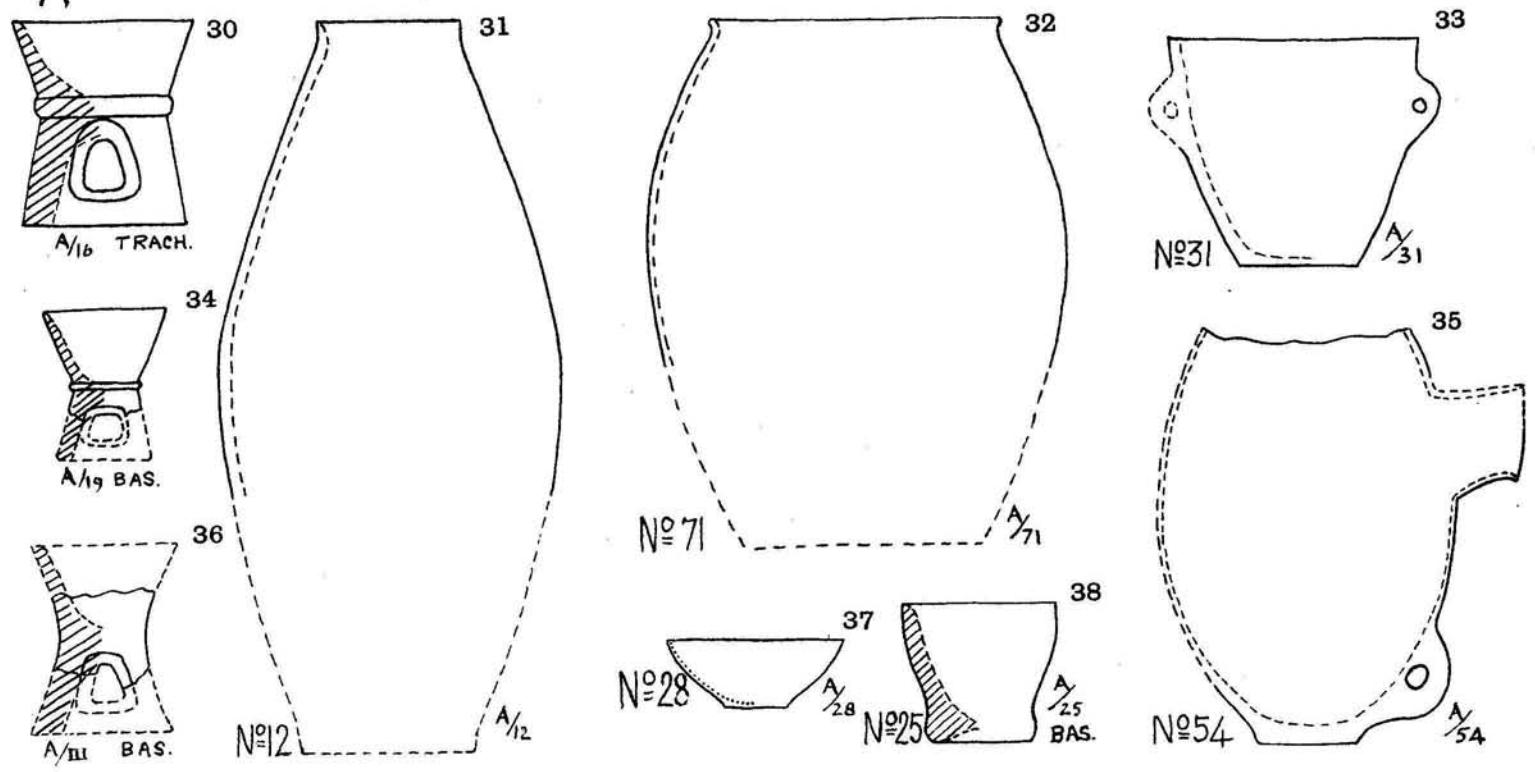



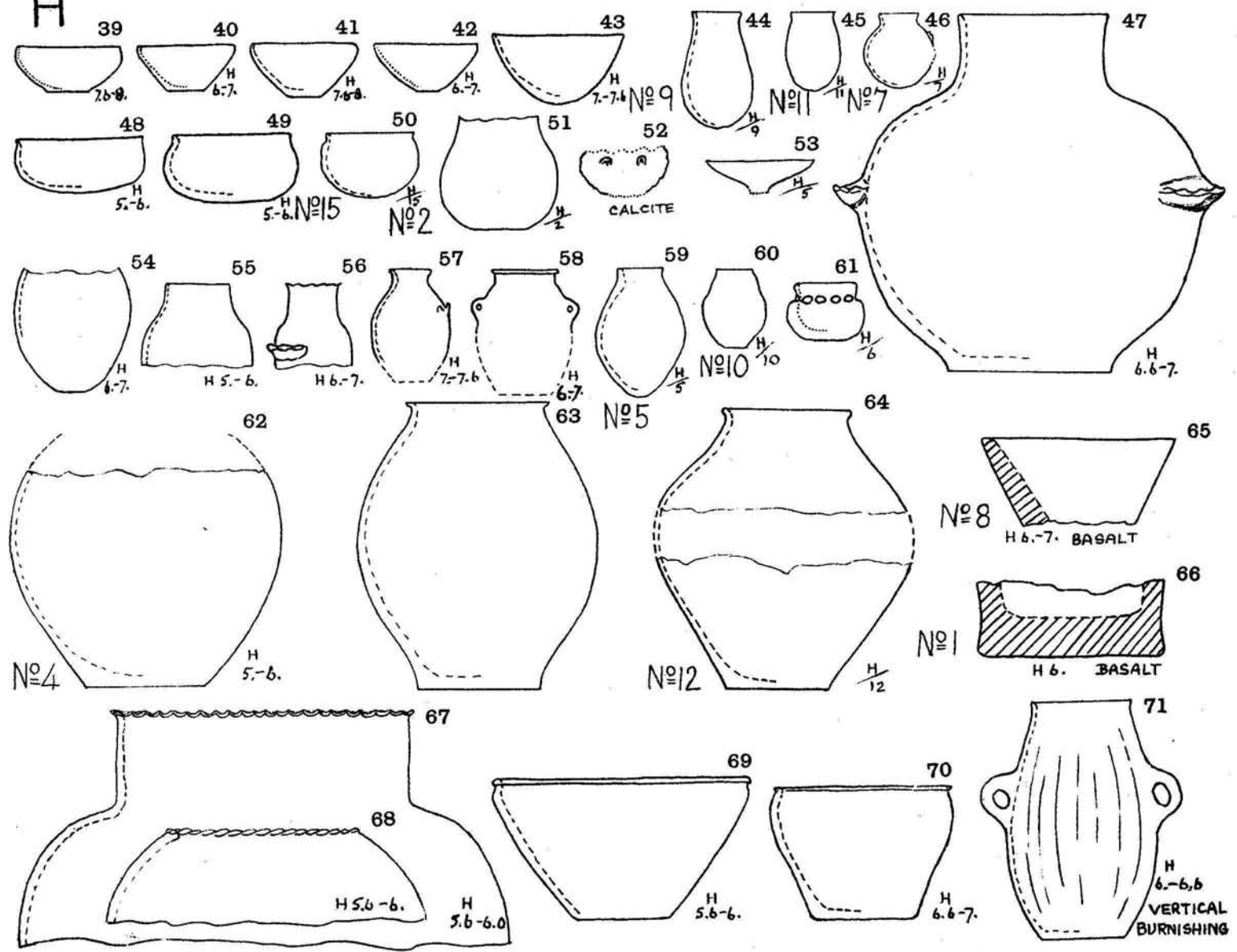

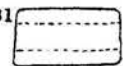

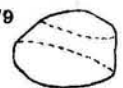



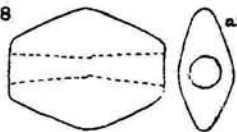
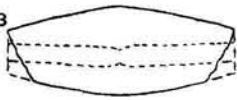
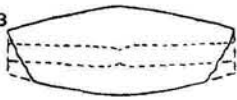

A

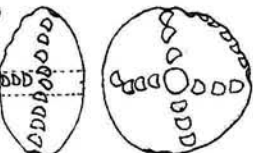

H



		DEPTH			DEPTH			DEPTH
A	CYLINDERS		N	(CONT.)		R	(CONT.)	
31	 grey limest.	A PIT 21	56	 clay	H 6'1"-7'		grn. felspar	M 8'10"-9'6"
D	BARRELS		70				ostrich shell	M 8'10"-9'6"
79	 clay	H 6'1"-7'	81	 blk. quartz	B LEVEL C	83	ostrich shell	M 9'4"-10'3"
				white limest.	A 0-9"		ostrich shell	M 11'10"-13'
129	 grn. felspar	A SURFACE	115	white limest.	M 2'6"-7'3"		ostrich shell	M PIT 19
				white limest.	M 3'1"-4'6"		bone	M PIT 19
149	 white limest.	O 2'6"-3'	16	silicate of copper	H 6'1"-7'		ostrich shell	D 2'1"-2'6"
F	LOZENGES		118				ostrich shell	M 1'7"-8'
8	 amazonite	A 0-9"	119				ostrich shell	O 0-6"
			120	grey quartz	M 7'4"-8'		ostrich shell	O 3'1"-3'6"
			125	grey quartz	M 10'4"-11'		bone	O 3'1"-3'6"
H	BICONAL BARRELS						ostrich shell	H 1'1"-5'
13	 clay	D 2'3"-3'6"	141				bone	H 5'1"-6'
			147				ostrich shell	M 1'10"-13'
56	 steatite	A 10"-16"	160				ostrich shell	H 1'10"-13'
J	SPHEROIDS		165	blue stained quartz	H PIT 13		ostrich shell	H 1'10"-13'
30	 clay	H PIT 16	169	calcedony	M 9'7"-10'3"		ostrich shell	H 1'10"-13'
57	 white limest.	M 8'10"-9'6"	170	calcedony	O 0-6"		ostrich shell	H 1'10"-13'
73	 carn.	A SURFACE	172	grn. felspar	M 9'4"-10'3"		ostrich shell	H 1'10"-13'
K	FANCY SPHEROIDS		174	blk. ostrich shell	A PIT 19		ostrich shell	H 1'10"-13'
10	 clay	D 1'4"-4'6"	175	white limest.	A PIT 23		ostrich shell	H 1'10"-13'
				white limest.	M 9'7"-10'3"		ostrich shell	H 1'10"-13'
				white limest.	M 9'7"-10'3"		ostrich shell	H 1'10"-13'
L	BICONAL SPHEROIDS		R	DISCS				
21	 brn. agate	D 2'3"-3'6"	14	 bone	H 5'1"-6'			
36	 clay	D 2'3"-3'6"	20					
N	RINGS		25					
19	 silicate of copper	A SURFACE	28					
20	 brn. limest.	D 1'6"-6'6"	29					
	alabast.	D 2'27"-3'	40					
	clay	H 6'1"-7'	81					
52	 clay	D 2'3"-3'6"	82					

XII D¹87-9. 15-56 7.-7.7 2.7-8. 3.7-7.7 D²37.4. 4.37-4. M8-8.9 B15 A 16 PIT PIT PIT PIT XIII
 3.7-4. 5.17-2. 1.7-2. E 0-2.8 7.0-2.8 B 17 B
 O⁸x 0-2.7 2.0-0.8 M 13-13.6 TOP 10.9-9.6 11.8.9 B B 18 B6. A TOP. A TOP. A72 APIT5 APIT72
 10-11 TOP TOP 13 TOP 16 TOP 12.-13. 12.-16. A TOP. A TOP

XV D8.6-9.6 6.-6.7 6.-6.7 E6.-8. 6.-8: 0-2.6 XVI 32 B 33 B4 34 B8
 E 0-2.6 O 1.8-2.8 .8-1.8 O/20 O/31 A.9-1.6 A5 35 A.9-1.6 A
 O 2.1-3. D² 2.-2.6 0-1.6 2.7-3. M 13.-12. 36 A/19 37 A/61 38 A/61
 M 13.6-13. 28 11.-10. 29 10.-8.6 30 TOP 9.7-10.3 39 A/20 40 A/2 41 A/19
 M 1.7-3. 2.-2.9 31 1.9-3. TOP 42 A/13 43 A38 44 A38

XVII D4.6-5 5.6 6.-6.6 6.6-7.0 45 7.7-8. D²46 3.7-4. 48 4.-4.6 E 0-2.6 O 2.0-3.6 III
 4.6-5. 47 TOP
 D² 3.-3.6 1.-1.8 3.7-4.0 2.-2.6 M 13.-12. 8.9-9.6 7.4-8 M 50 TOP TOP TOP
 B TOP TOP TOP TOP TOP 52 TOP 53 A.9-1.6 54 TOP A.9-1.6 III M TOP 61 O E4:5.
 H 6.7 6.7 45 55 6.7 56 PIT 10 57 6.6-7. 58 TOP 59 E 60 D6. D2.6-3. H PIT 16

XVIII D¹ 6.-6.7, 5.6-6. E/B, 0.-2.6, 0.6-1.6, /21, 2.8-3.8, 62 X, D² 3.6-4, 2.-2.6, M 13-12. 10.-9. X 9.3 B A B B A
 A.9-1.6 A/7 63 A/16 64 A TOP 65 A1 H 7.6-8. 7-7.6 6.-7. 4.-5. 7.-7.6 6.-7. H 6.-7. 66 7.6-8. H TOP
 — H 7.6-8. — — H TOP —
 D¹ 7.-7.7 E 6.-8. E TOP O/D D² 0-2.8 M TOP M 13.-13.6 M 2.6-7.0
 6.6-7. III B/A B B B A .9-1.6 9-1.8 0-9 H 6.-7. 7.-8. 3.6 0.-2.
 B B B B B A 0.-.9 IX H 6.-7. H 5.-6. H
 H 7.-7.6 6.-7. 6.-7. 5.-6. .6-6. 0-4.

XXVII M 71 TOP H TOP 73 H 6.-7. M 13. III M 11. II M 9. II 73 M8. XXIX E 6.3-6.8 EGYPTIAN
 74 H 5.-6. 75 D PIT 7 76 A/52 77 Fx 366. O.3-2.6
 78 A/65 79 A/1 80 SHELLAL W. OF WADY D INTRUSIVE .6-3.0 O 3.6-3.0 O 1.0-2
 81 F/x 82 A/11 4 ARROWS X M TOP M 10.-11. M TOP D² 10-11
 D¹ 4. 3. M 3. D 4. B LEVEL B A 0-9 A.9-1.6
 D 7. 83 A TOP 84 A PIT 18 F 22K 360.

XXX D¹ 6.8-8.6 7.-8. I 8.-8.6 8 6.-6.6 8.6-9.
 2 6.6-7. 8.-8.6 6.6-7.
 D² PIT 5 0.-1.6 2.-2.6 0.-1.6 2.-2.6 2.6-3. 4.6-3.0
 0-2.6 .8-6. 6.-3. 6.-8. 8.-6. 1.6-0
 E 8.-6. HEARTH 2 6.-3. 6.-3. 2.6-1.6 2.8-1.8
 O .6-1.6 PIT 13 1.9-2.6 .6-1.6 0/32

XXXI M 11.-12. 12.-13. 11.-12. 13.-14. 6.-3. 8.-9.
 2.-3. 7.-8. 1.6-3. 8.-9. 7.-3. 8.-7.
 B B/A B/A B/A B/B
 A 1-0 PIT 20 PIT 11 0-1. 1.-1.6 PIT 22 PIT 13
 PIT 7 1-0 PIT 7 PIT 20 1-0 1.6-1. 1.-0
 H 5.-4. PIT 111 PIT VII 7 6-7 7.6-7.

XXXII D¹ 7-8 5.-5.6 PIT 1 6.-8. 5.-8.
 6.8. 3.-5. 3.5 0-2. PIT 1 3.-5. PIT 1 PIT 1
 O 6-1.6 PIT PIT PIT 21 29 1.6-2. 2.6-3.
 2.-3 21 0-2. 24 PIT 21 PIT 21 1.6-2.
 O 2 D3 O D3 O PIT 29 O D1. O PIT 23
 D² 2-2.6 2-2.6 2.-2.6 2.-2.6 PIT 5
 2.-2.6 3.-3.6 1.6-2. 1.6-2. 2.-2.6 2.-2.6
 M 11.-11.9 10.-11.8-8.9 7.-8. PIT 5 2.-2.9 3.-5. 2.-3. PIT 4

XXXIII M 13.-12. 8.-9. 13. 11.-13. 11.-12. 3.-7. 3.-6.
 13.-11. 3.-2. 3.-2. 0-2. 0.-2. 3.-2.
 13.-11. 3.-2. 13.-11. 3.-2. PIT 7
 B PITS 3.-6. 13 B B
 A 0-1. 1.-1.6 0-1. PITS PIT 6 0.-1.
 0-1. PIT 1 PIT 17 PIT 22 PIT 6
 H TOP TOP 4.-5. 7.-7.6 TOP
 5.-6.

8.7-9.0 = 8FT. 7INS. TO 9 FT

II III IV FOLLOWING ENTRY = NUMBER OF EXAMPLES.

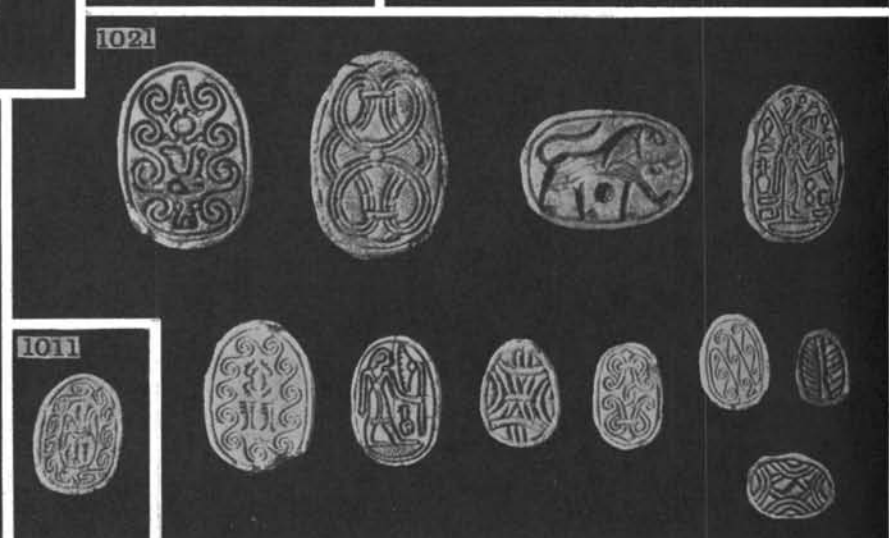
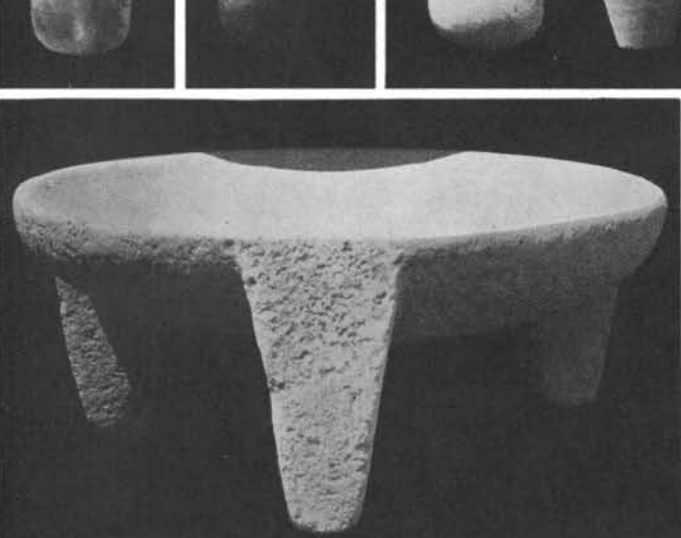
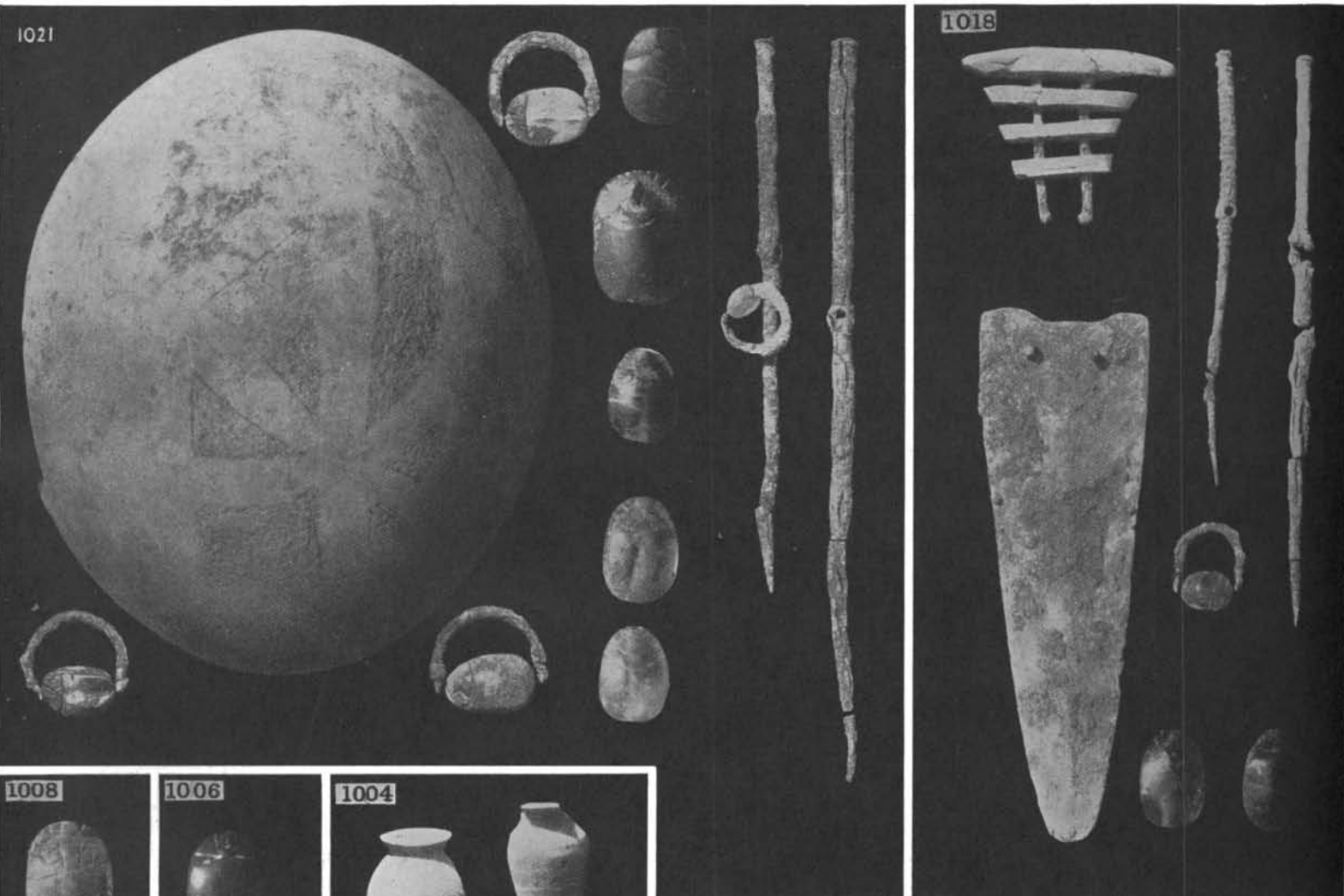

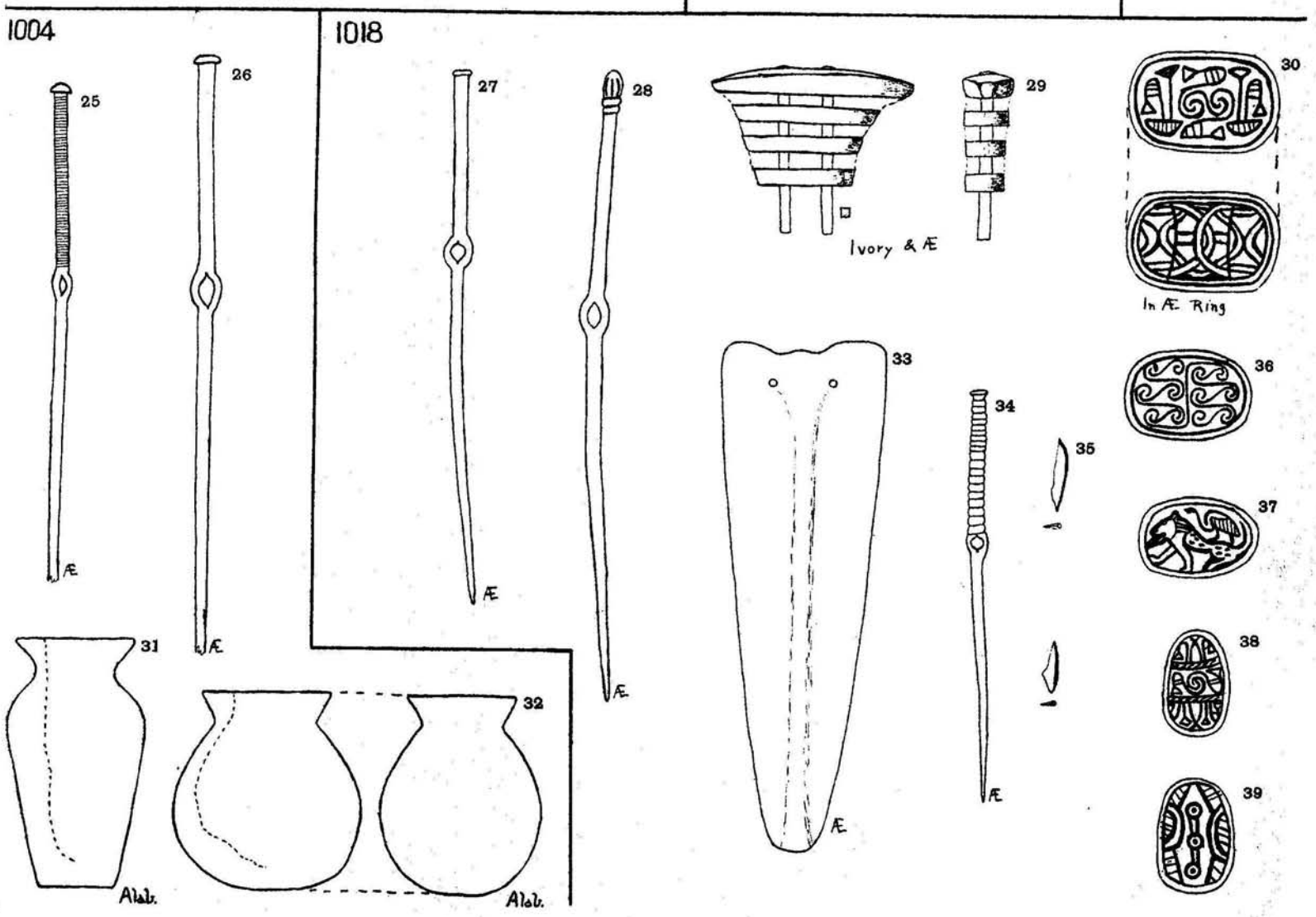
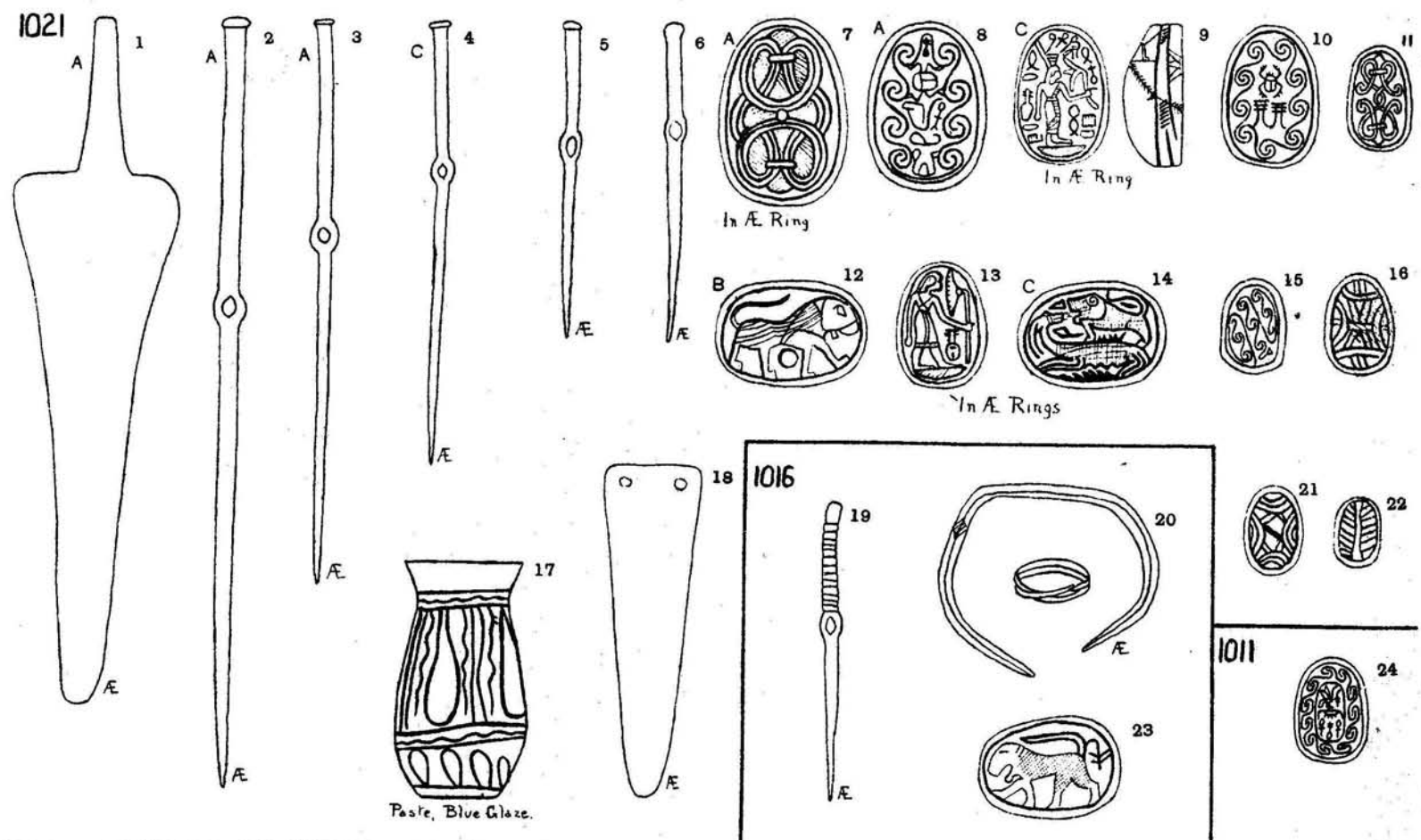

1:1 SCARABS.
1:2 BRONZE.

BETH PELET. TOMB GROUPS HYKSOS.

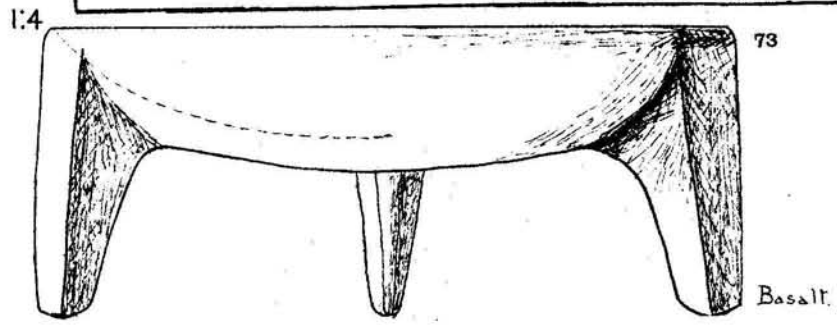
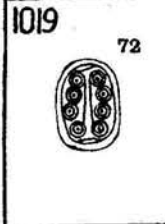
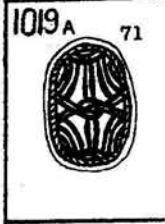
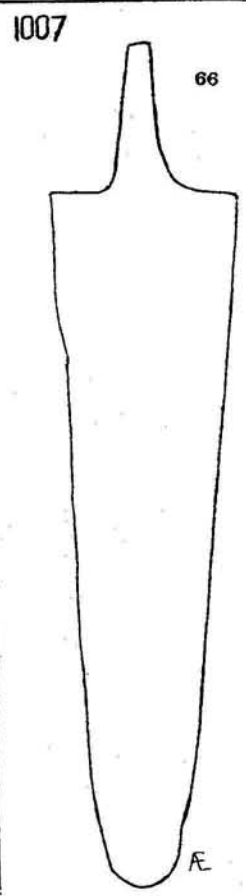
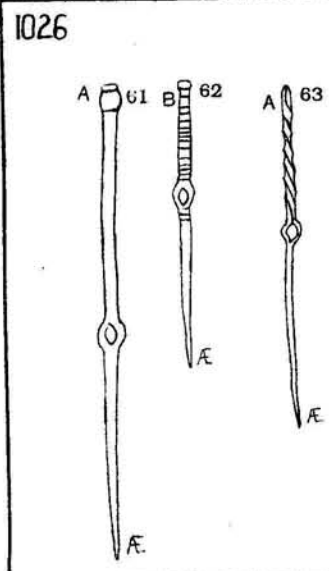
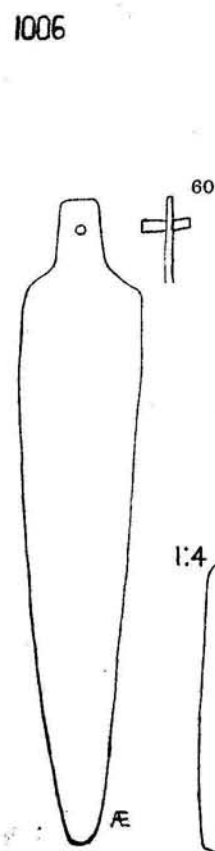
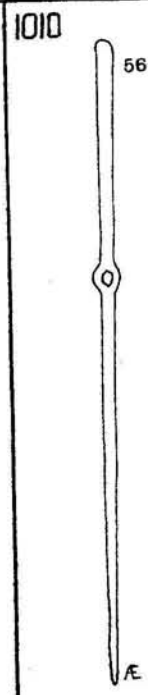
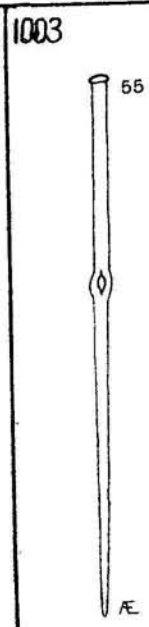
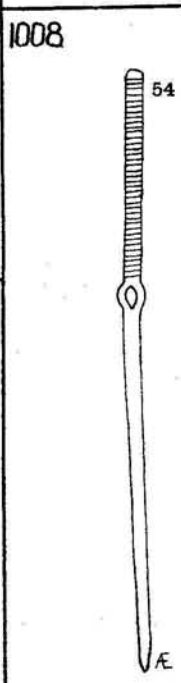
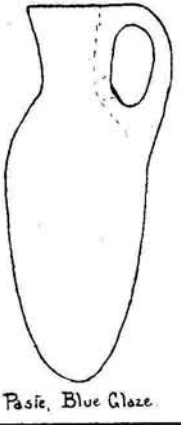
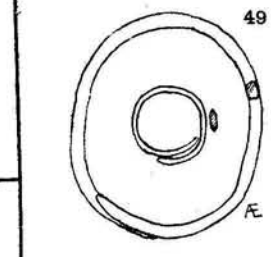
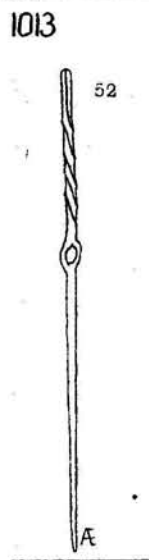
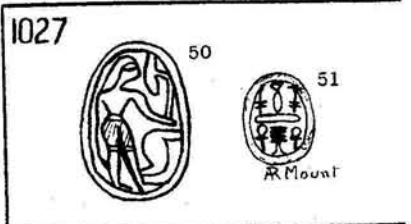
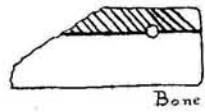
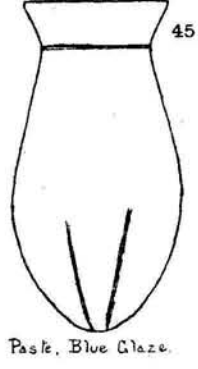
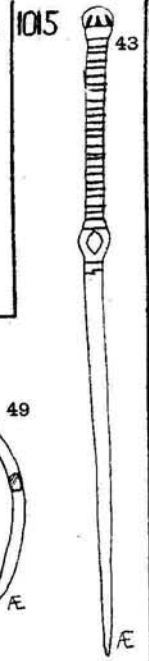
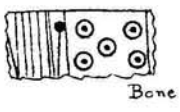
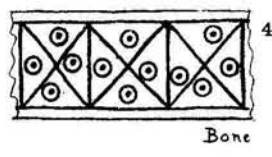
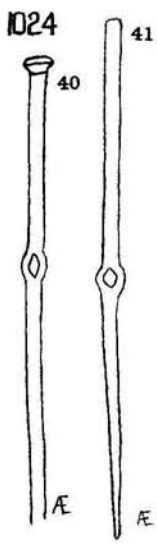

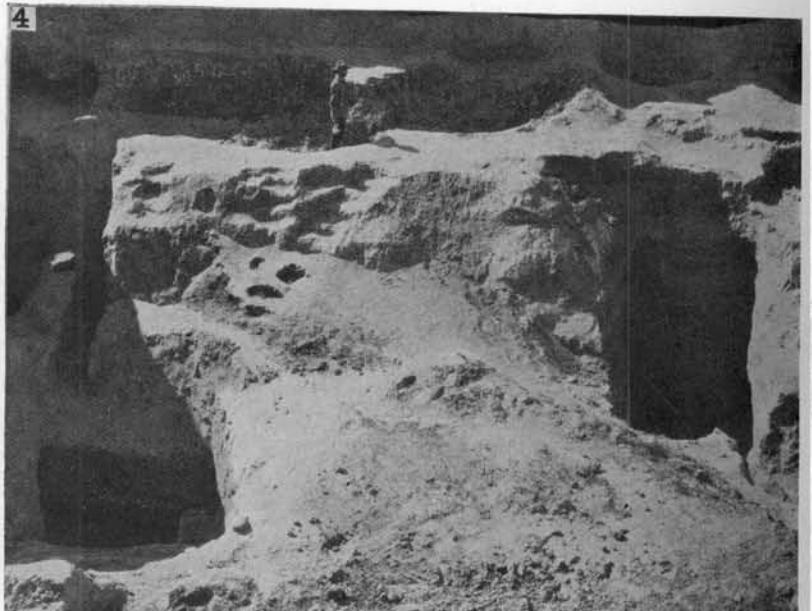
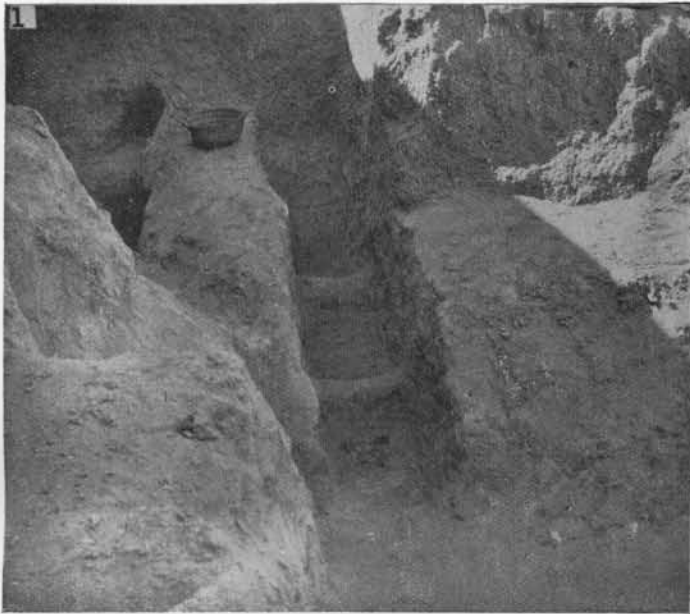

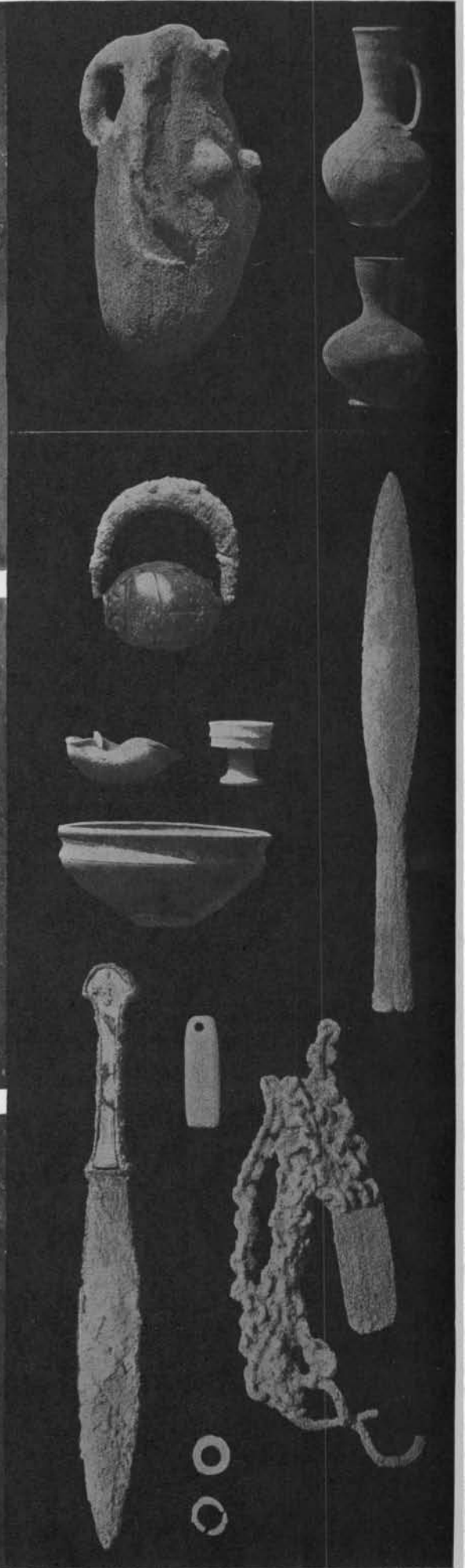
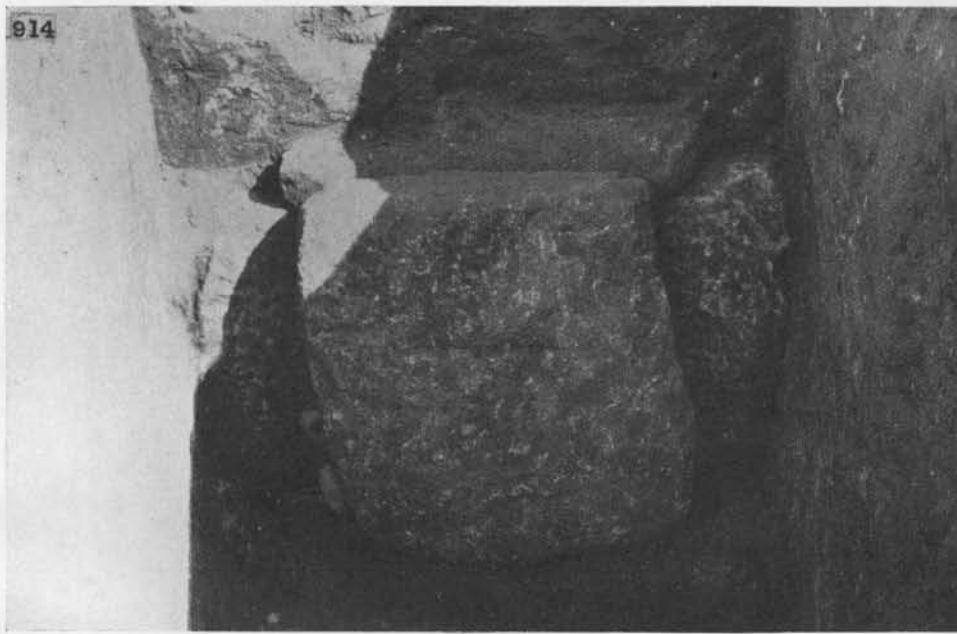

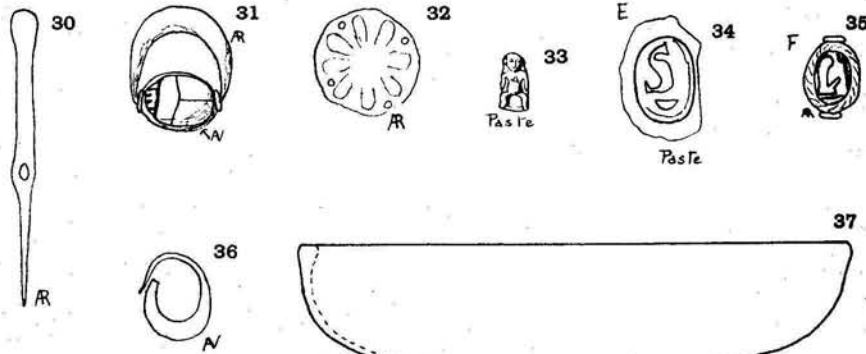
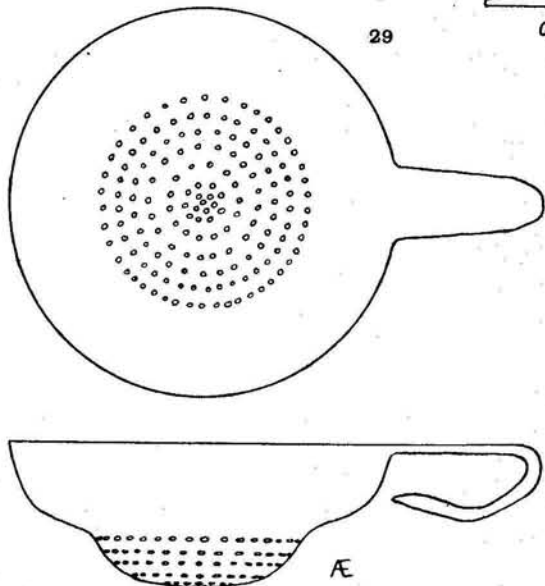
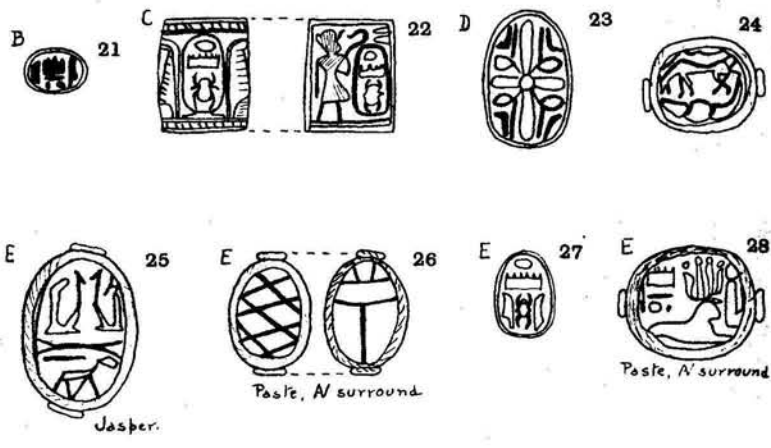
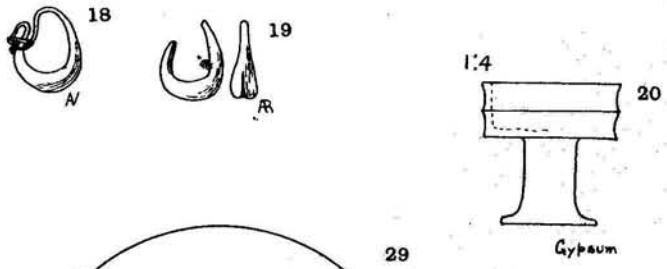
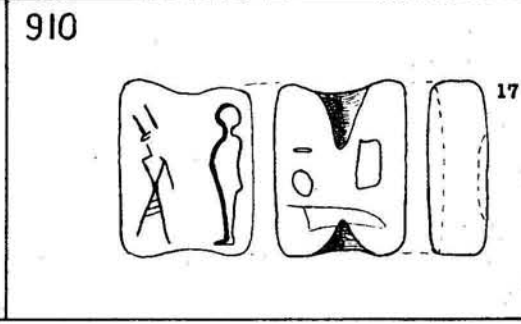
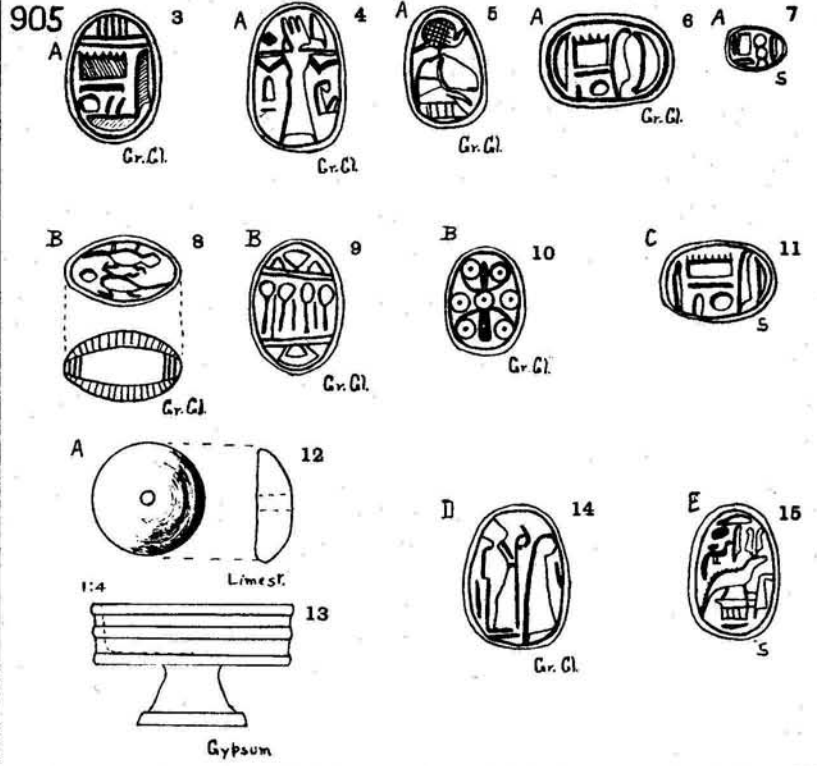
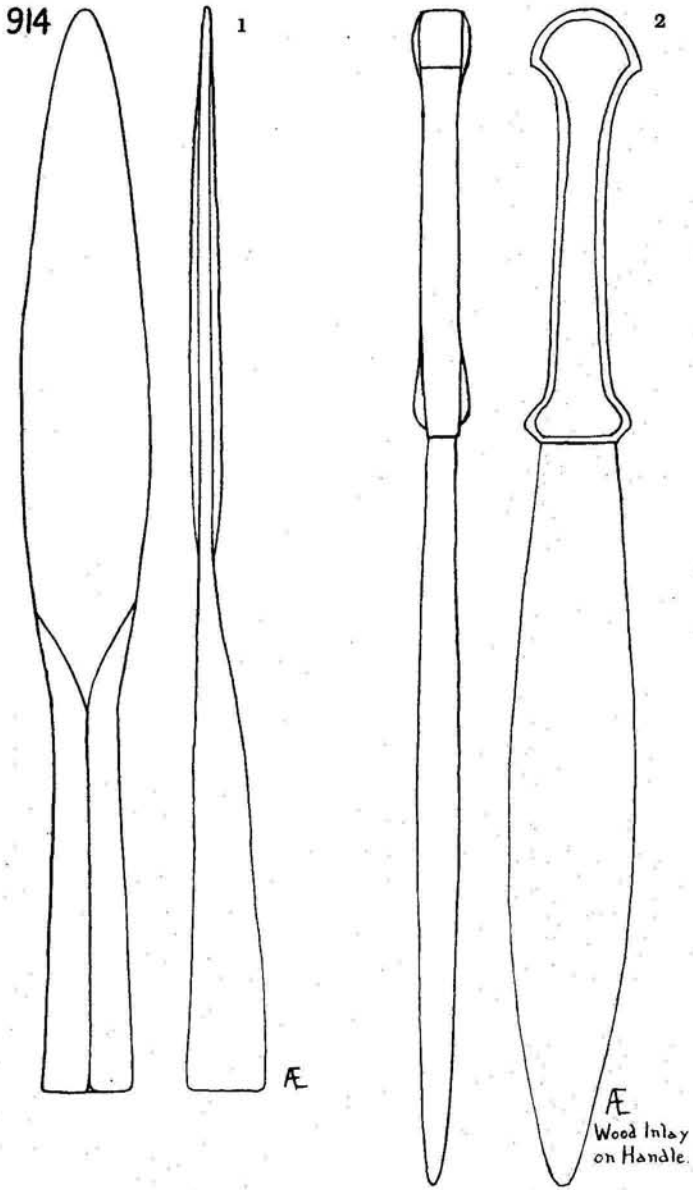

1:2 BEADS. 1:1 SCARABS. 1:6 POTTERY.

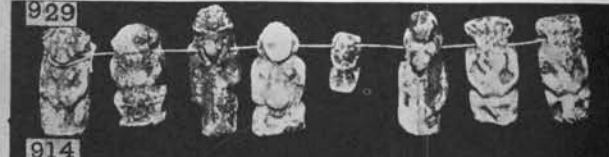
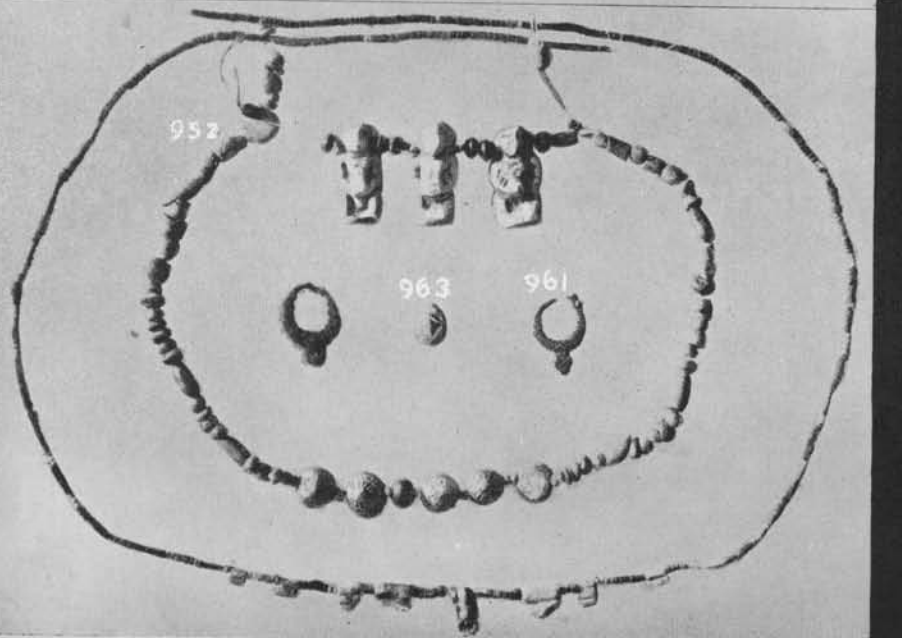
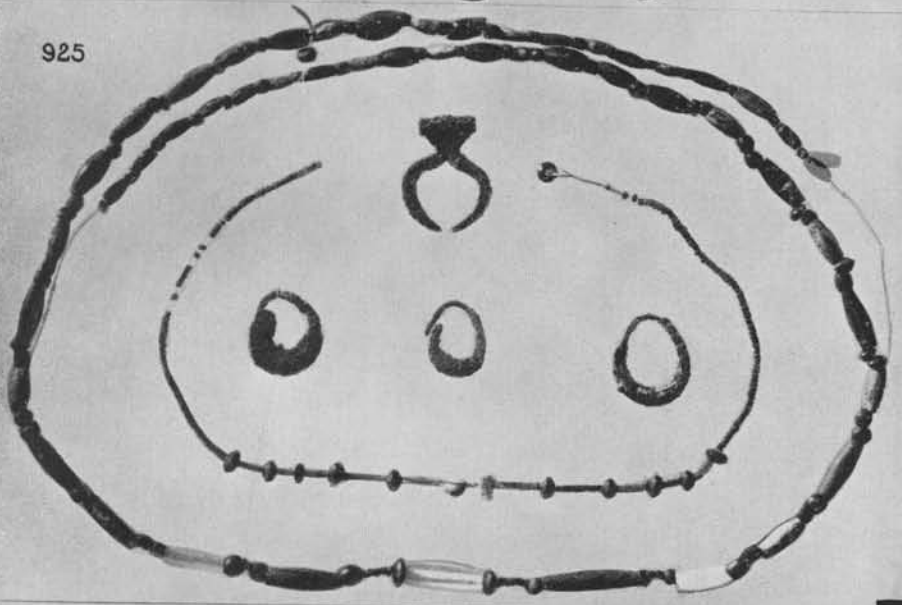
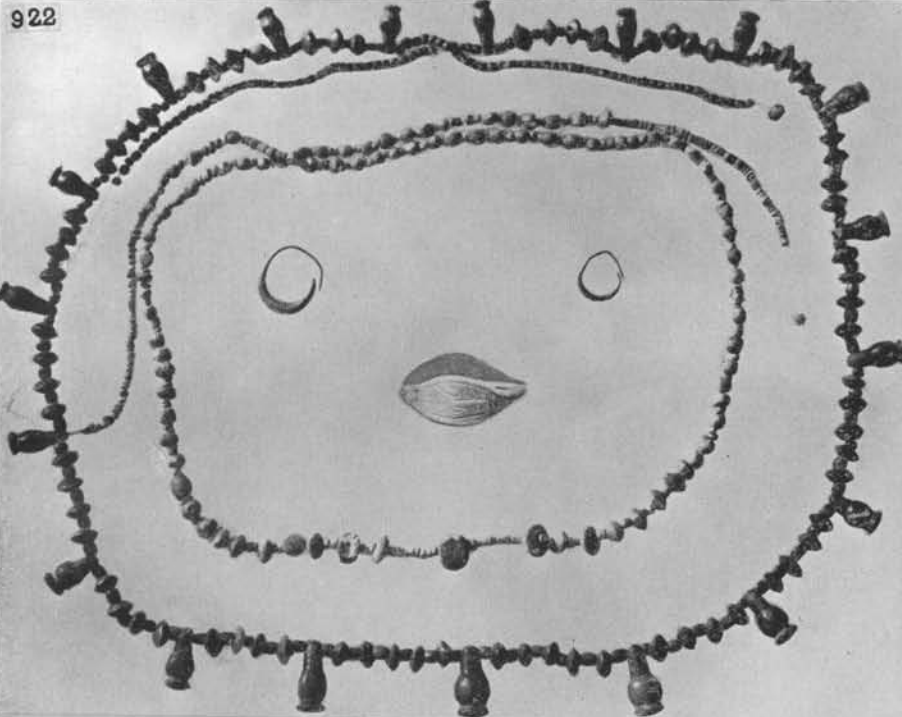

1.1 SCARABS.
1.2 BRONZE.

BETH PELET. TOMB GROUPS 915 TO 978.

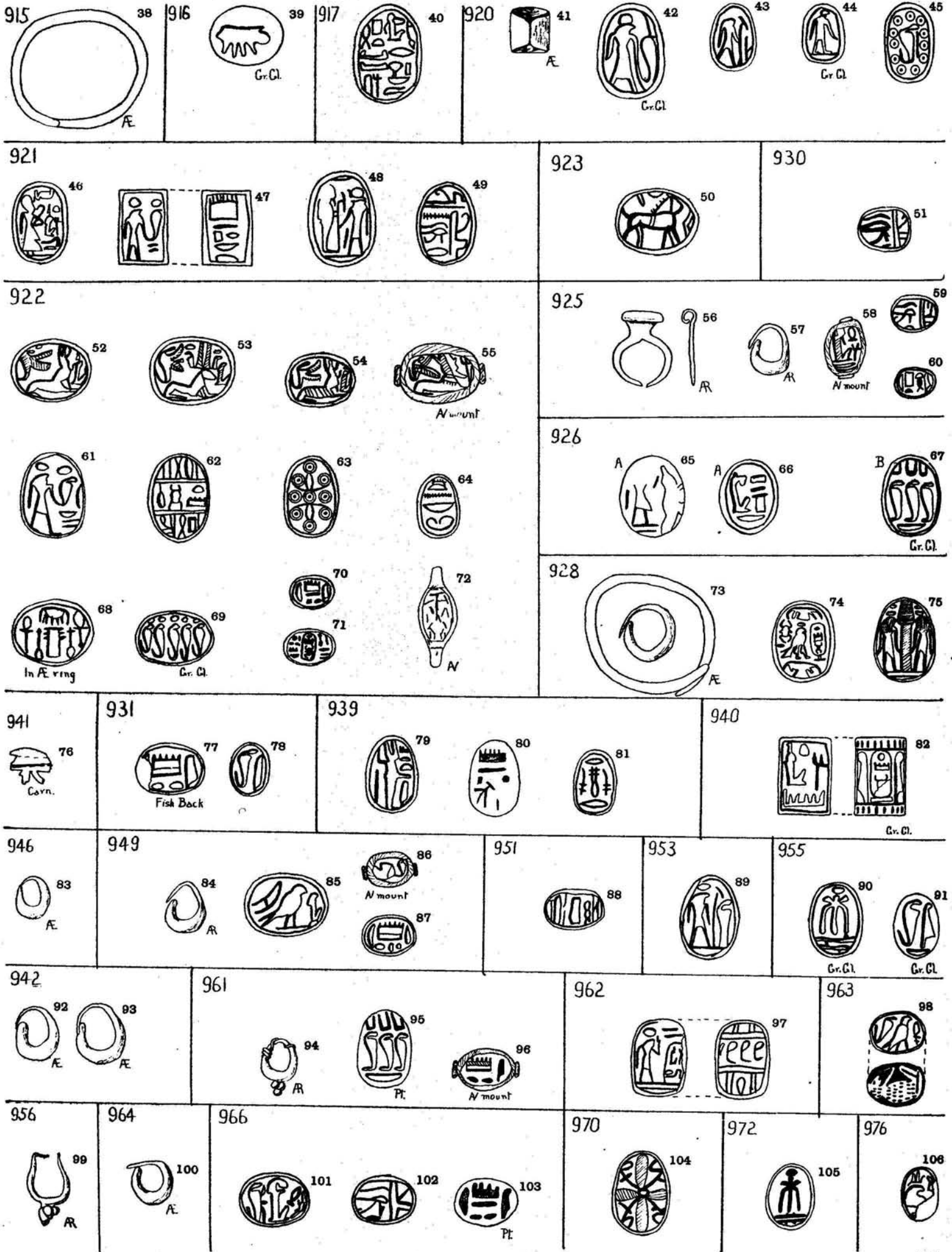



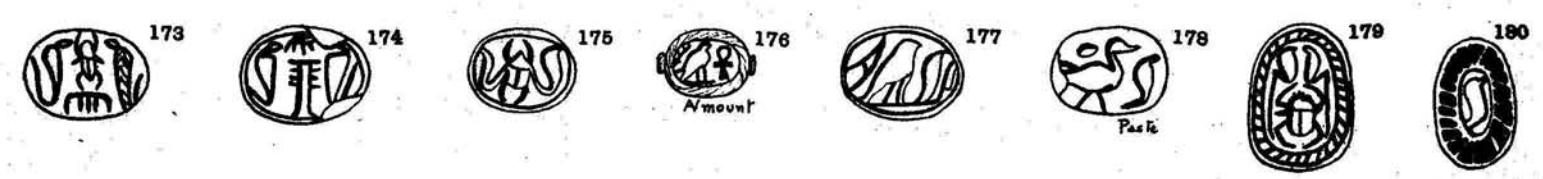
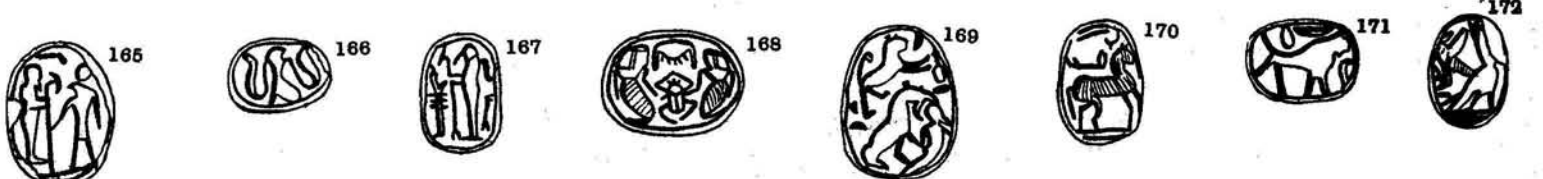
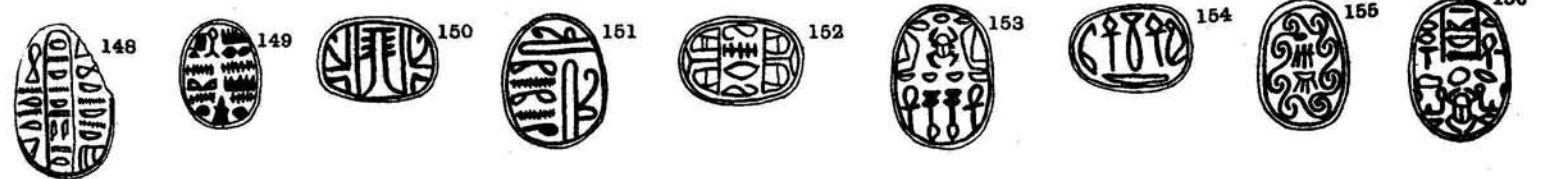
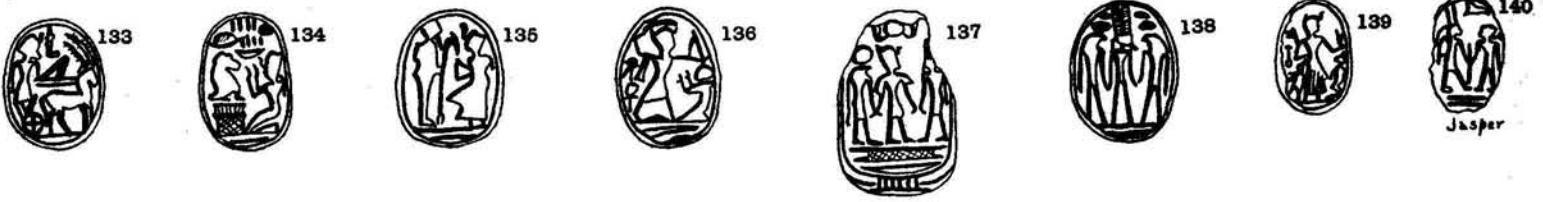
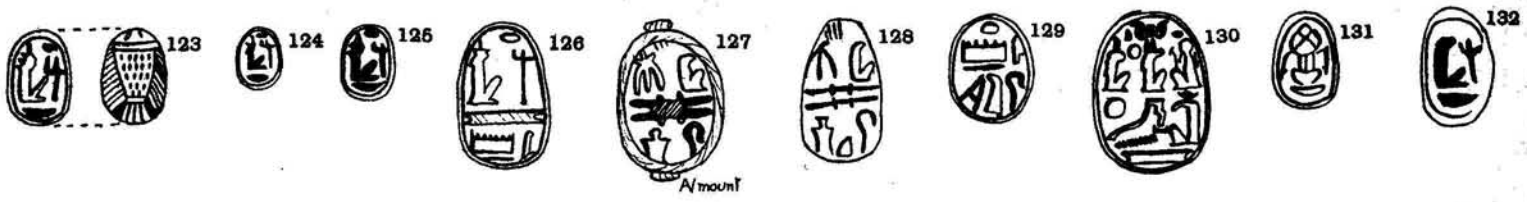
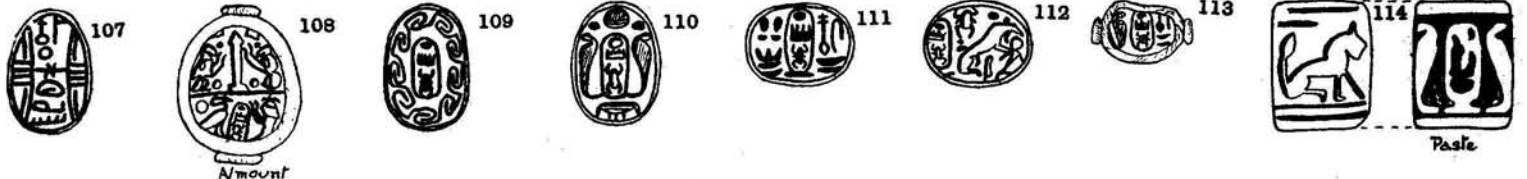

934 (cont)

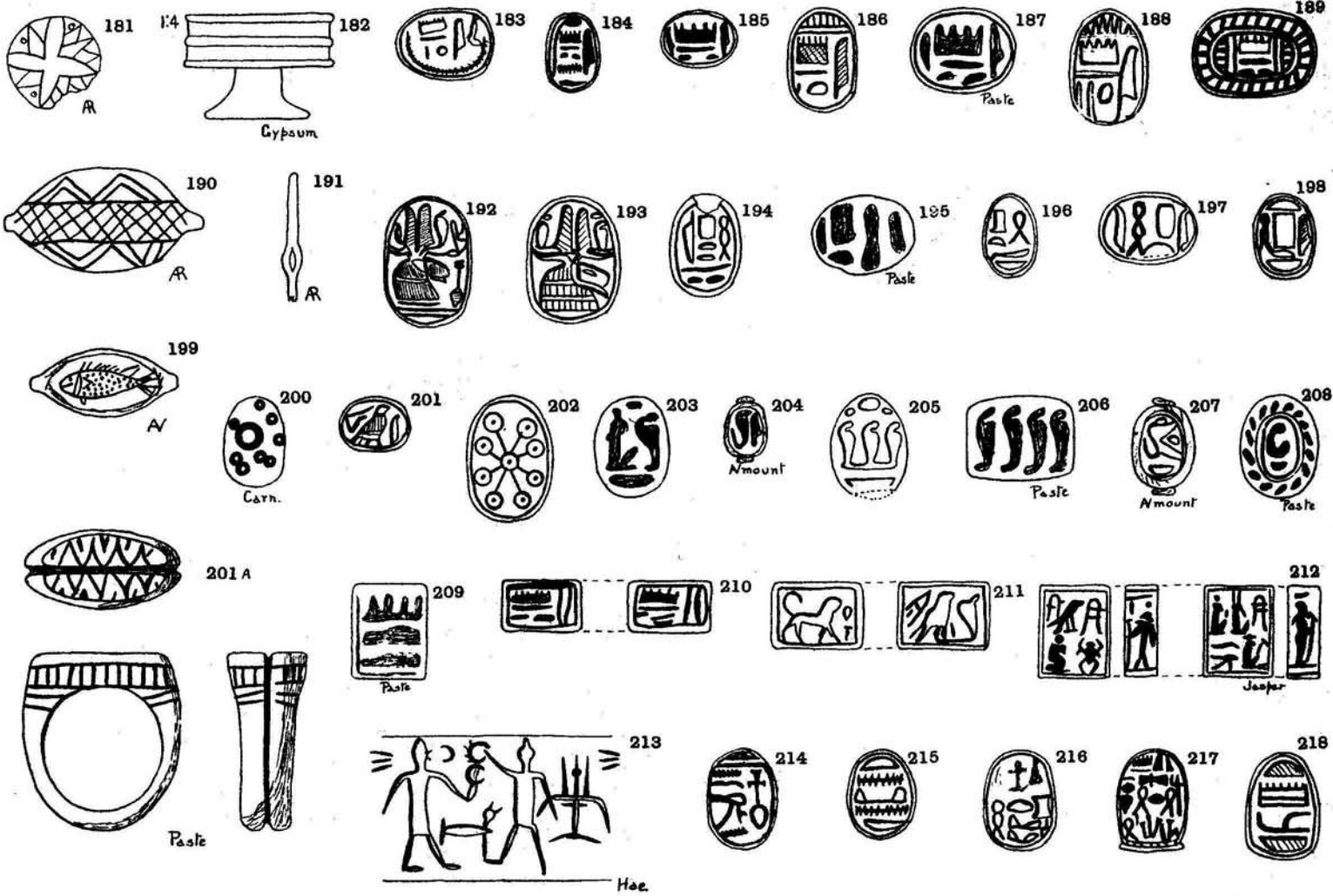

935

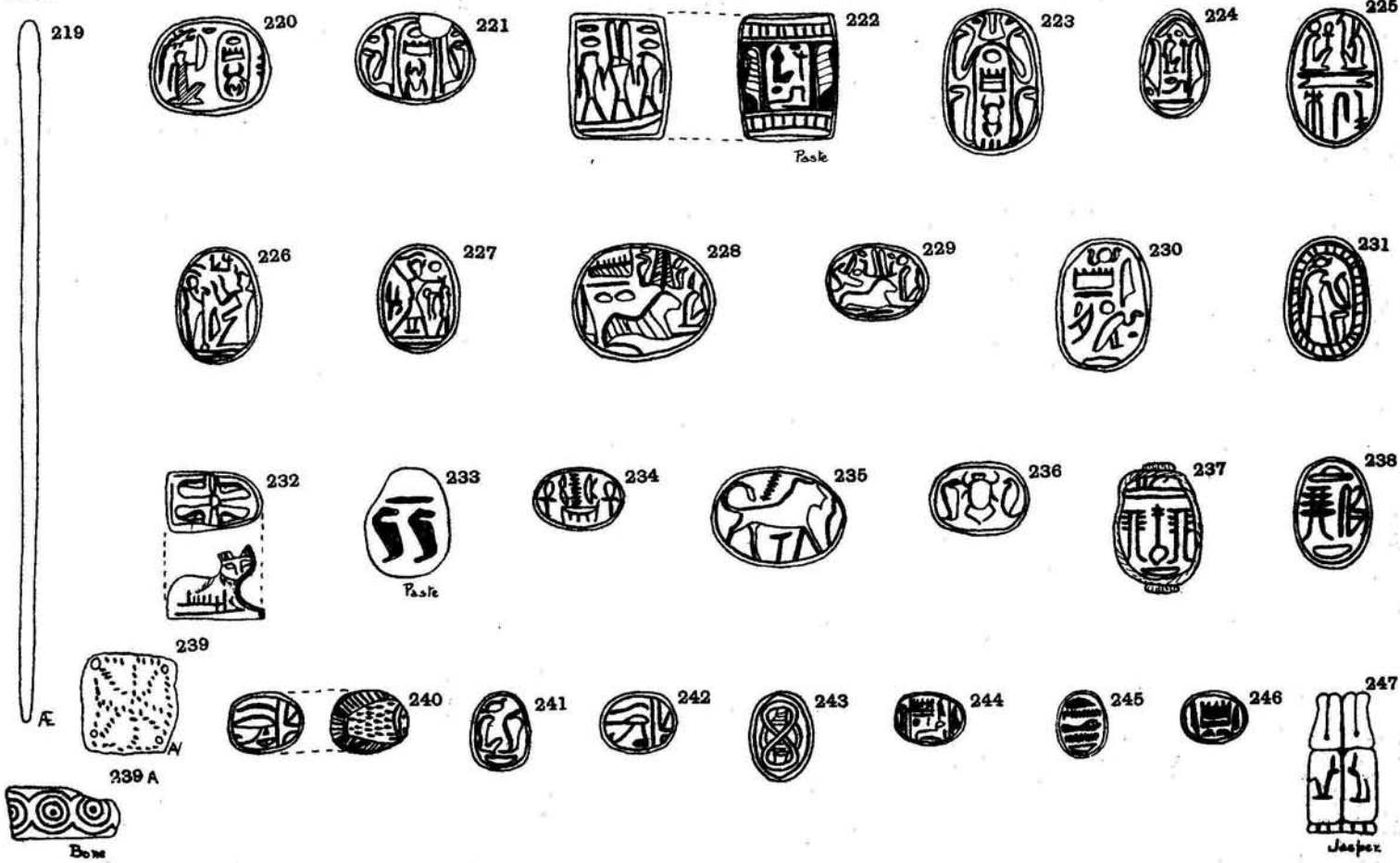

1:1 SCARABS. 1:6 POTTERY. 1:2 REMAINDER.

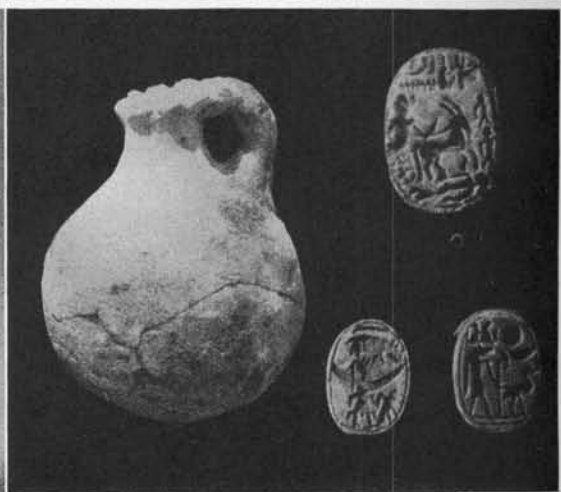
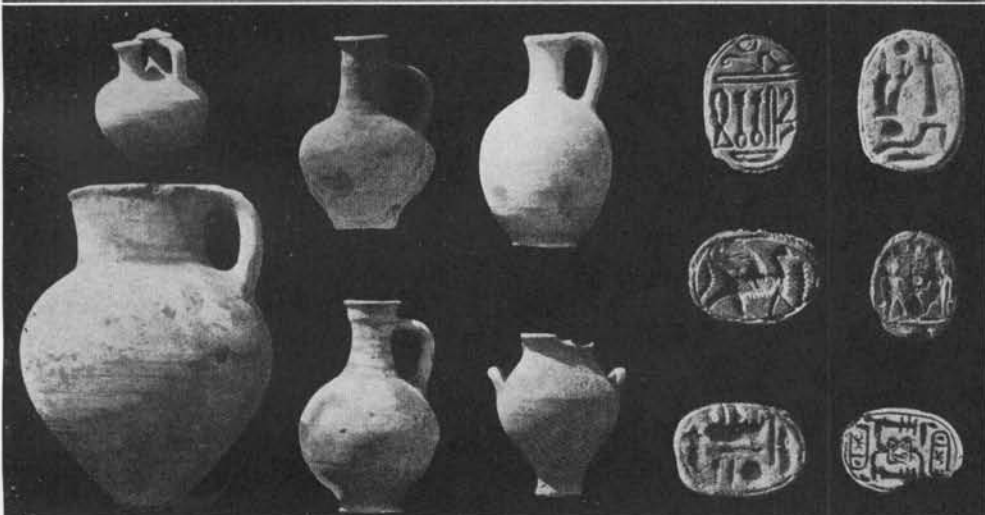
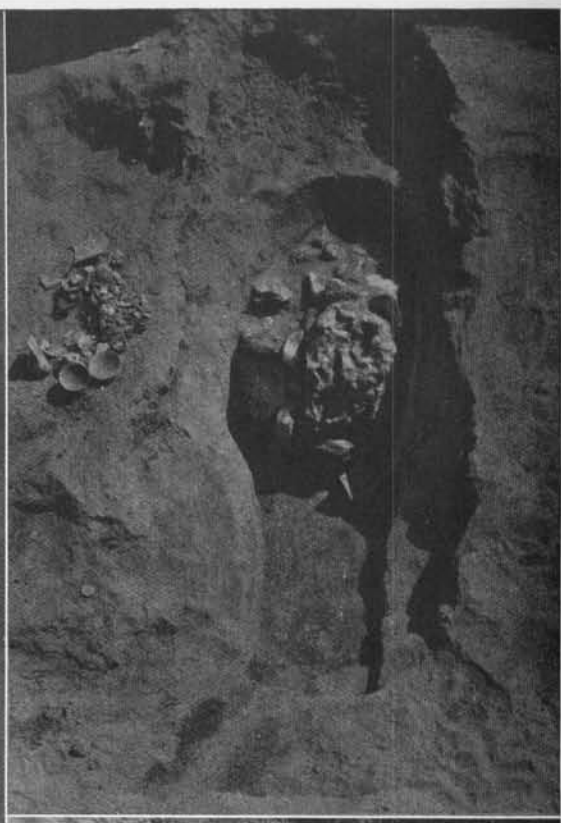
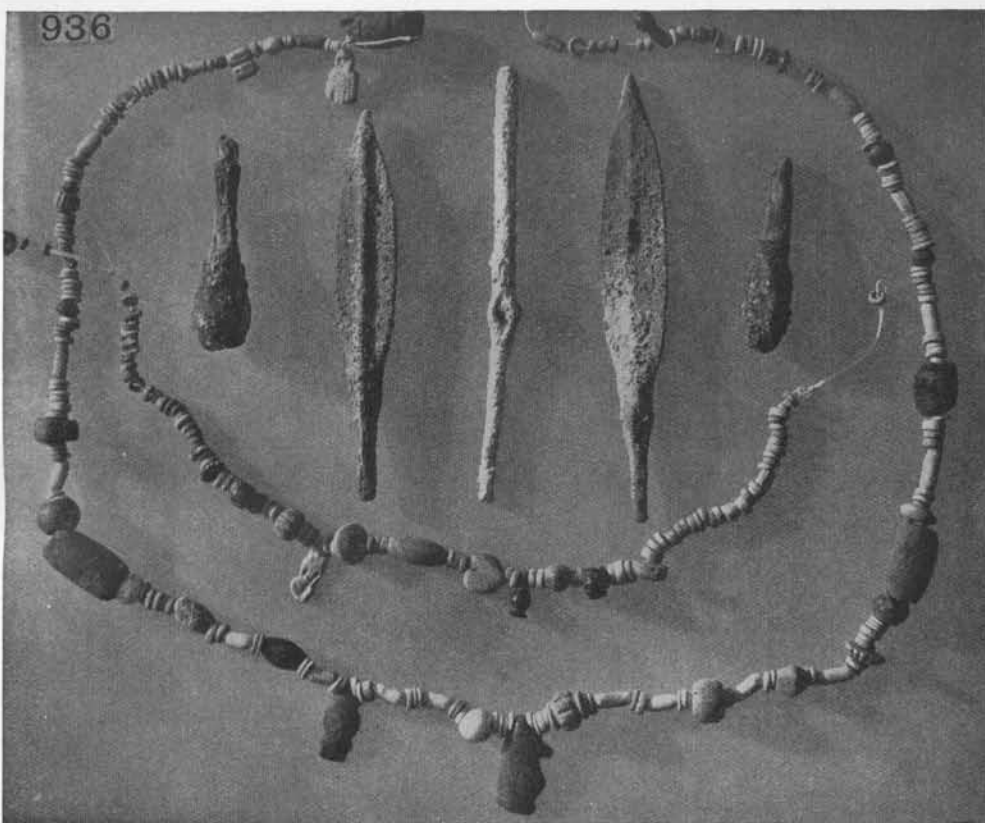

984

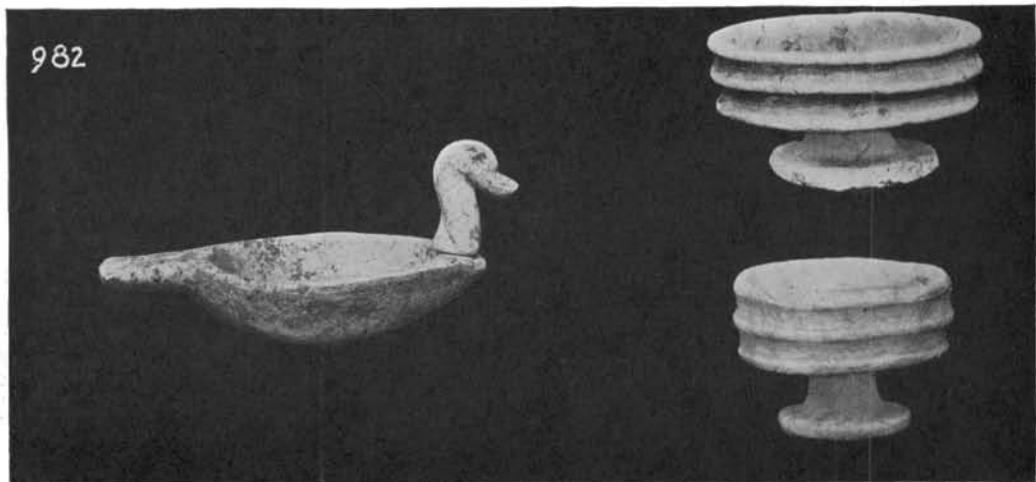
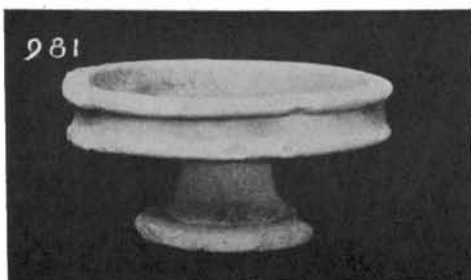
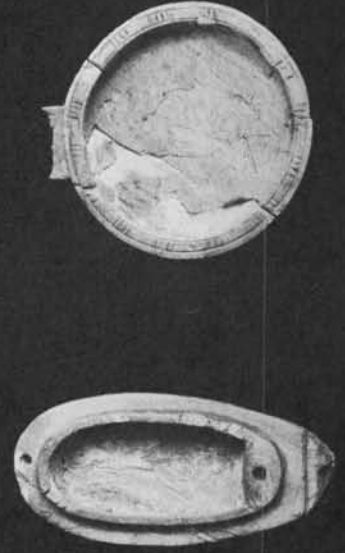
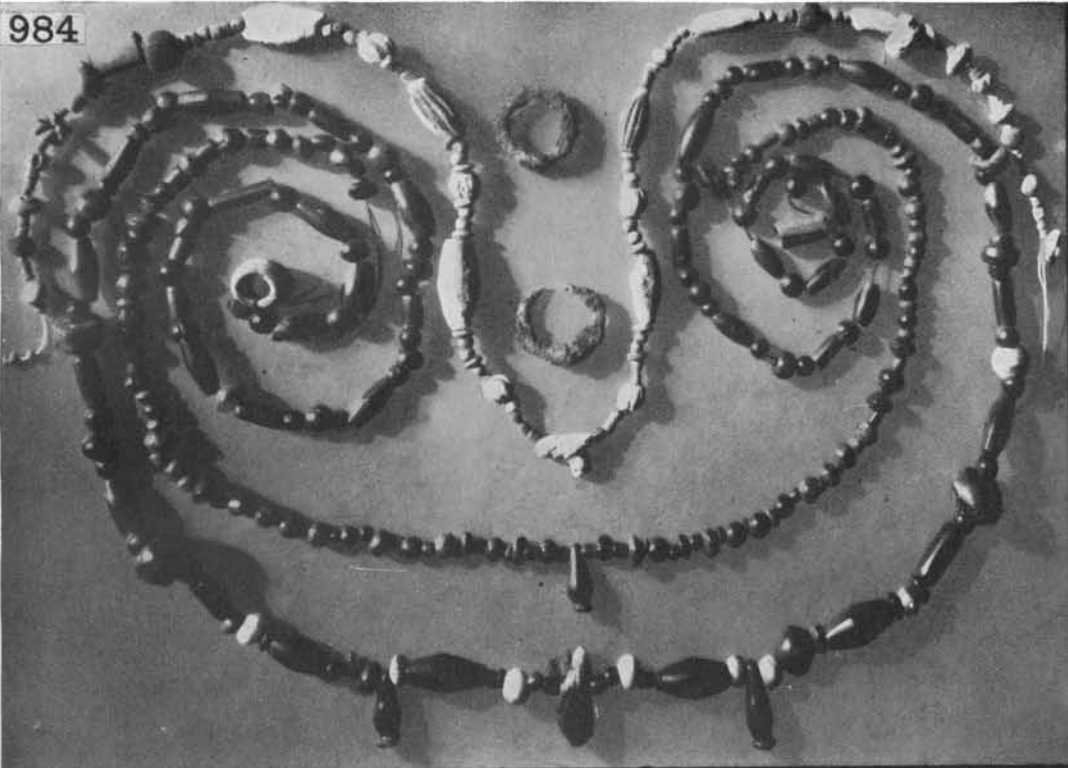

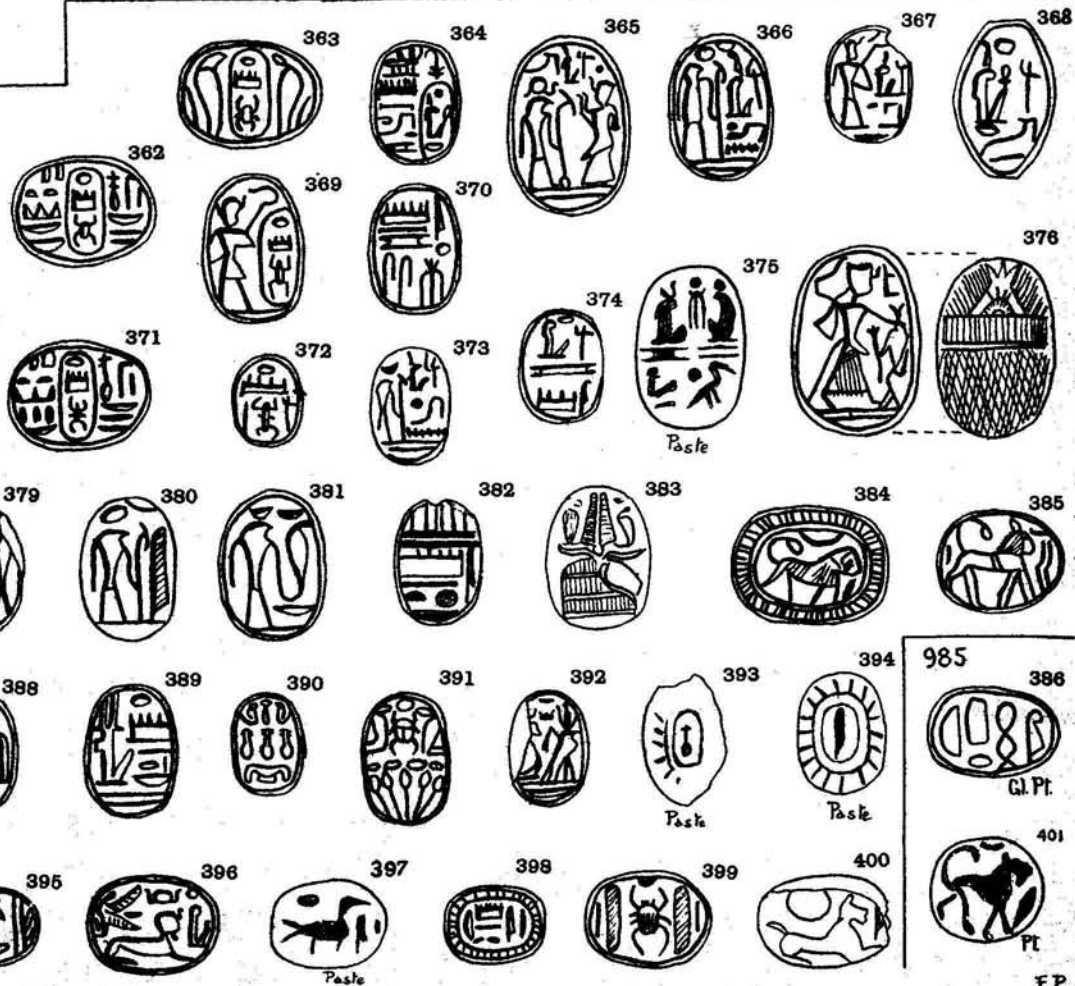
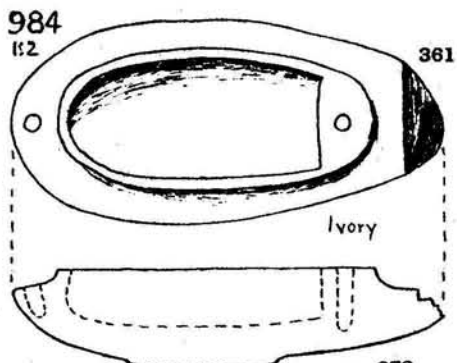
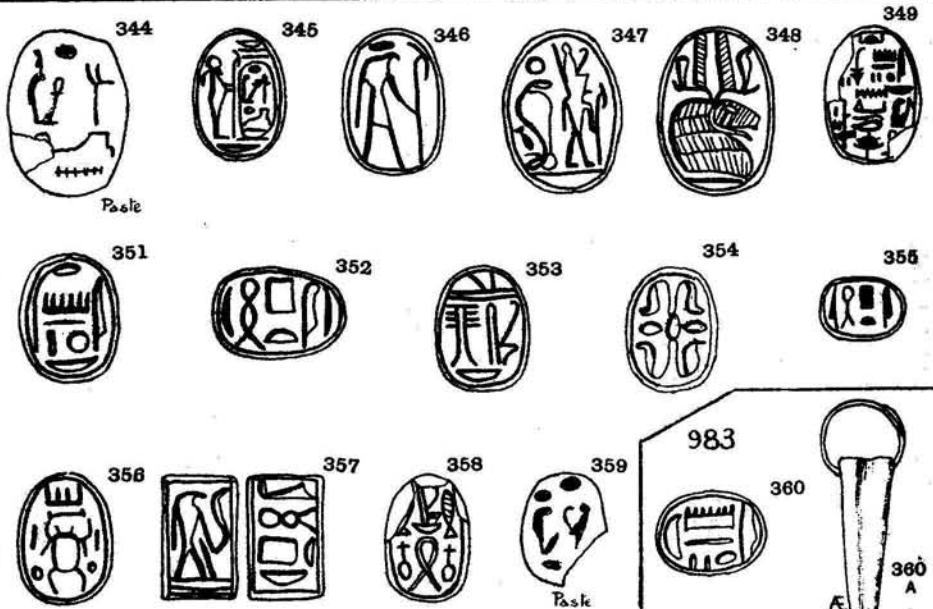
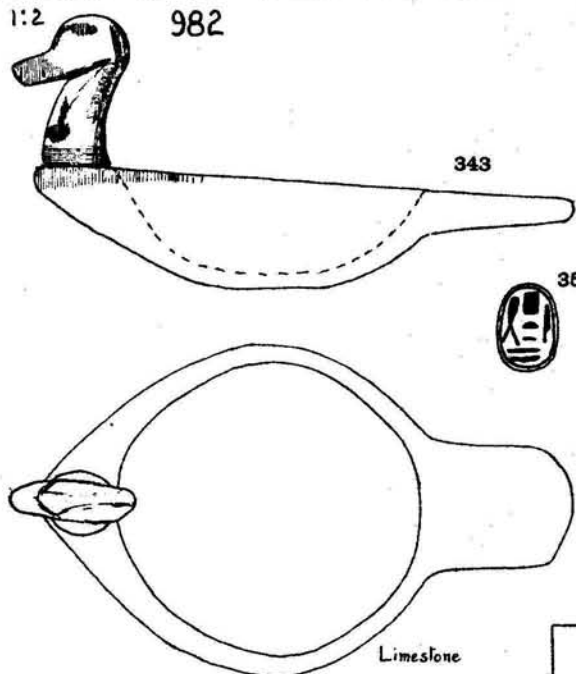
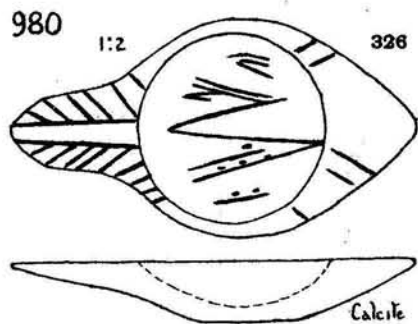

978



972



920



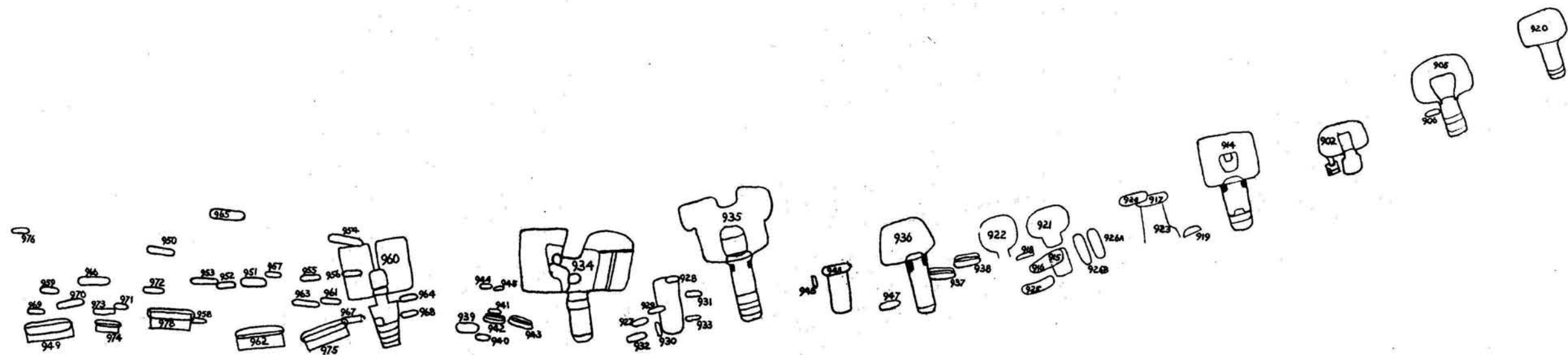
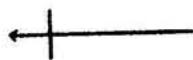



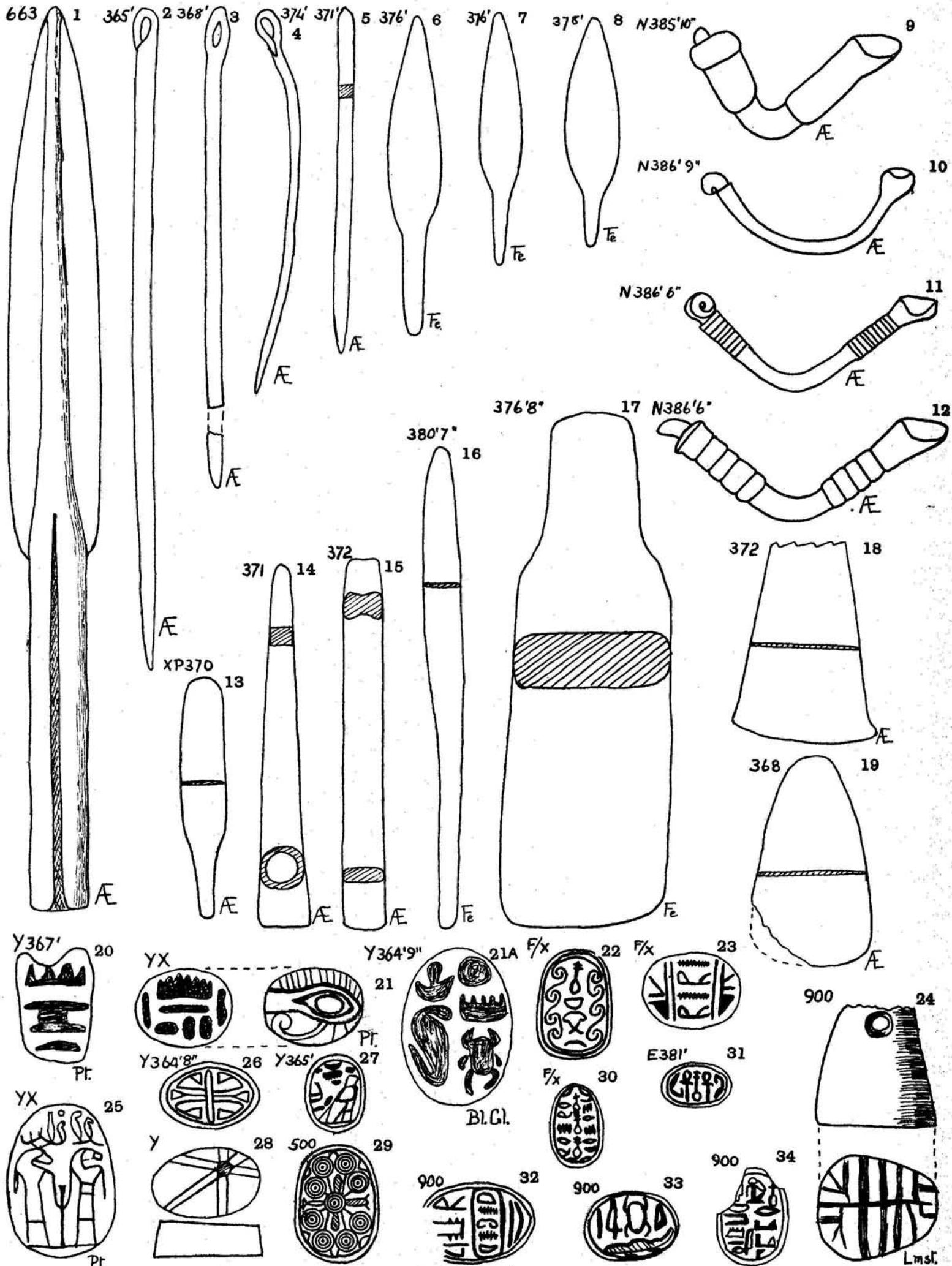

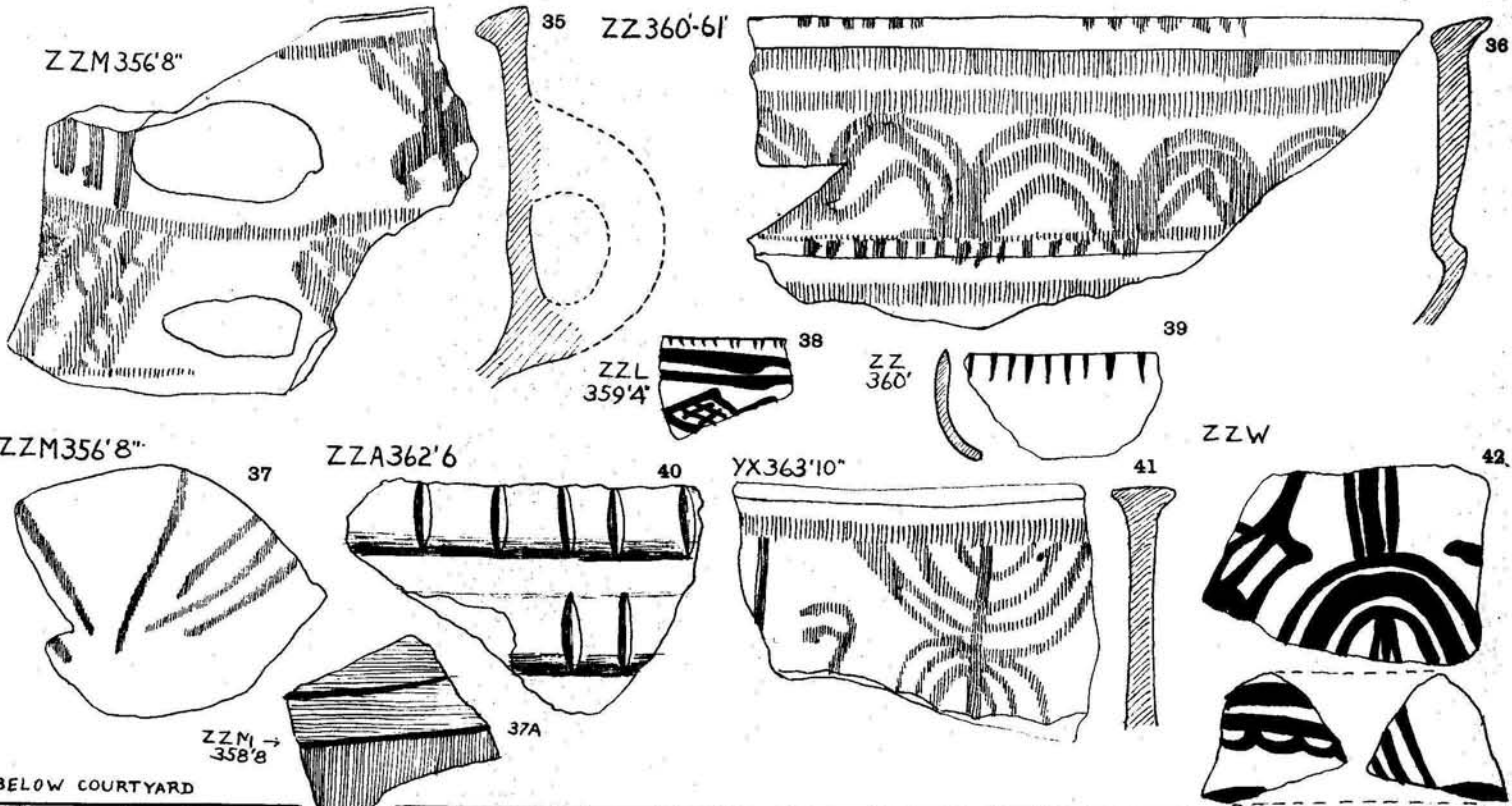

BELOW COURTYARD

ABOVE COURTYARD

YEE364-70'

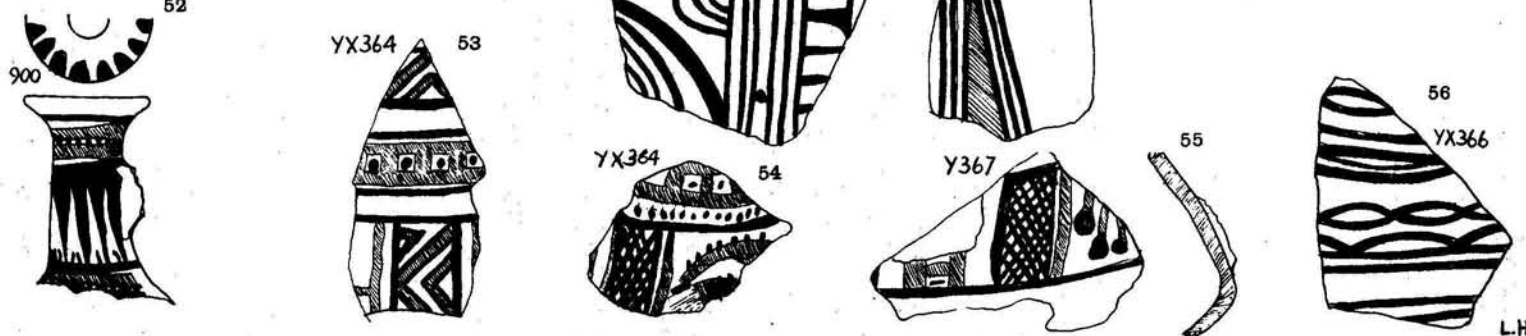
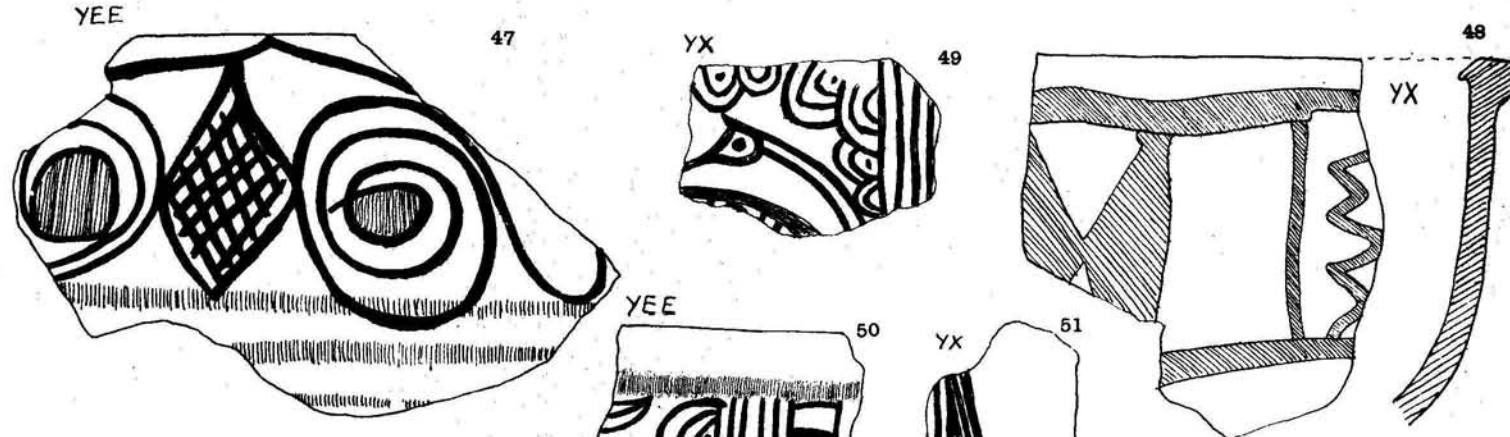
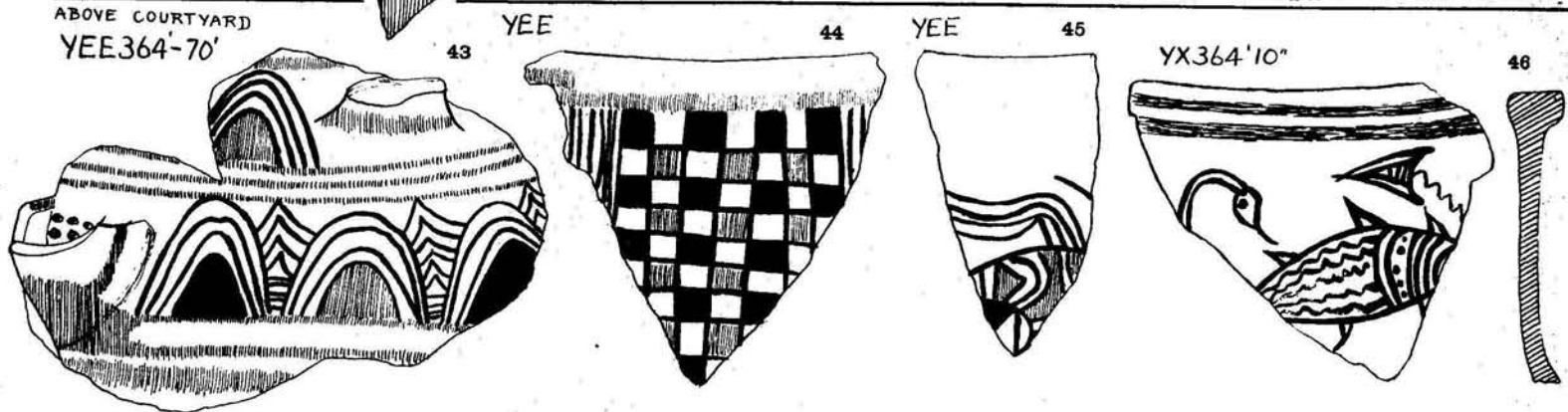

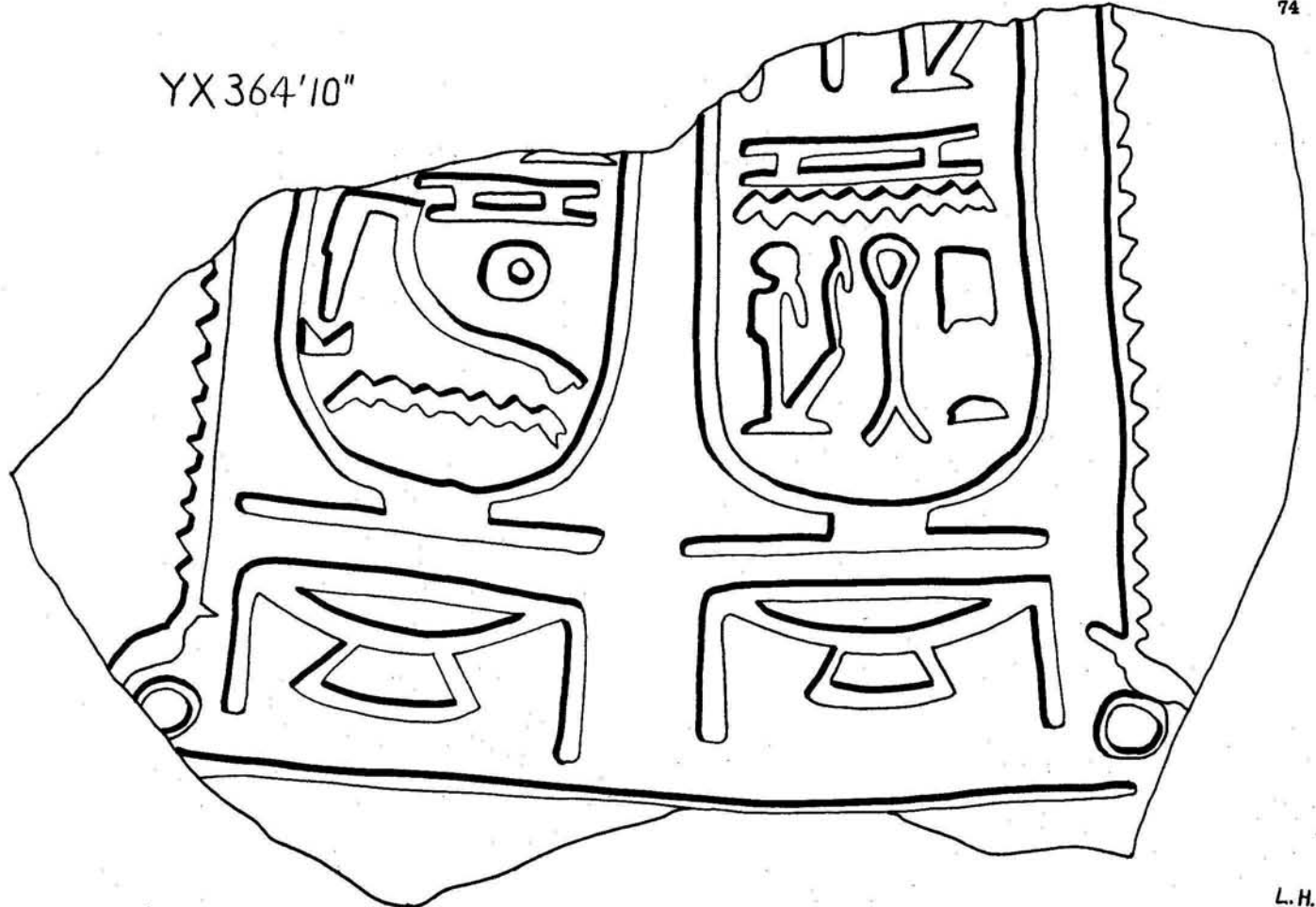
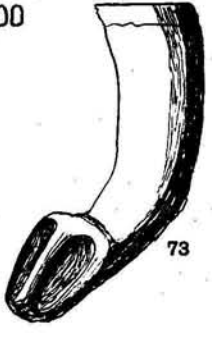
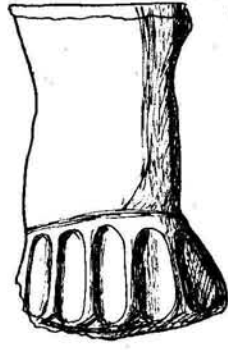
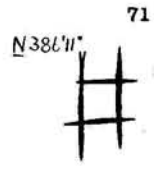
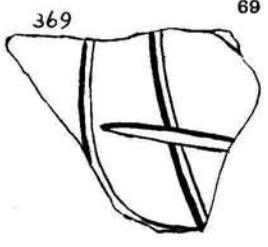
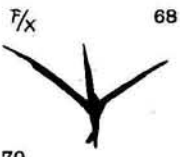
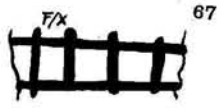
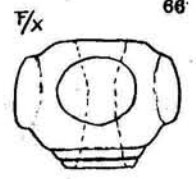
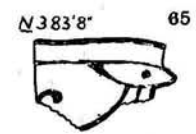
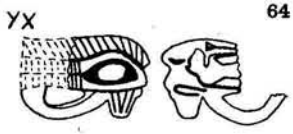
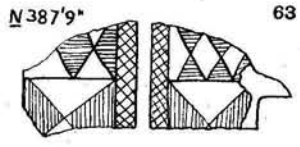
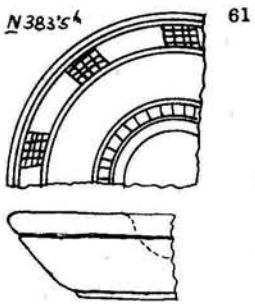
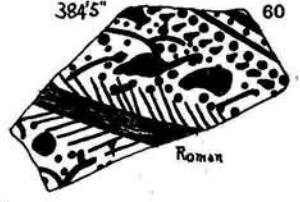
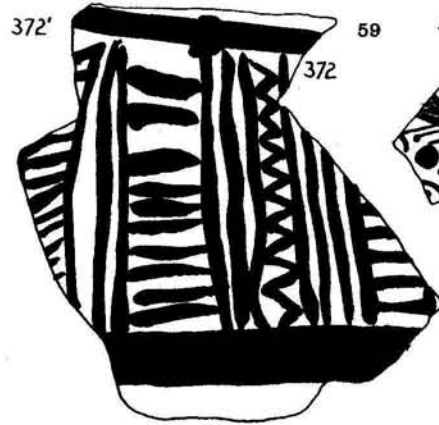
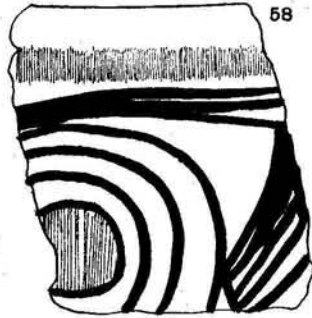
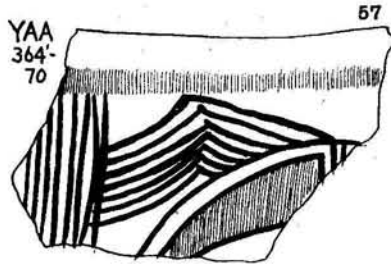

ZZX seen from NE

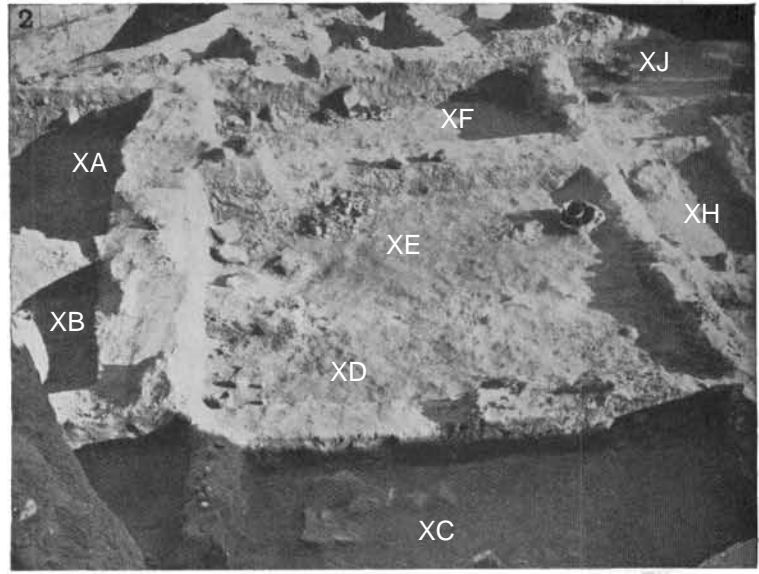
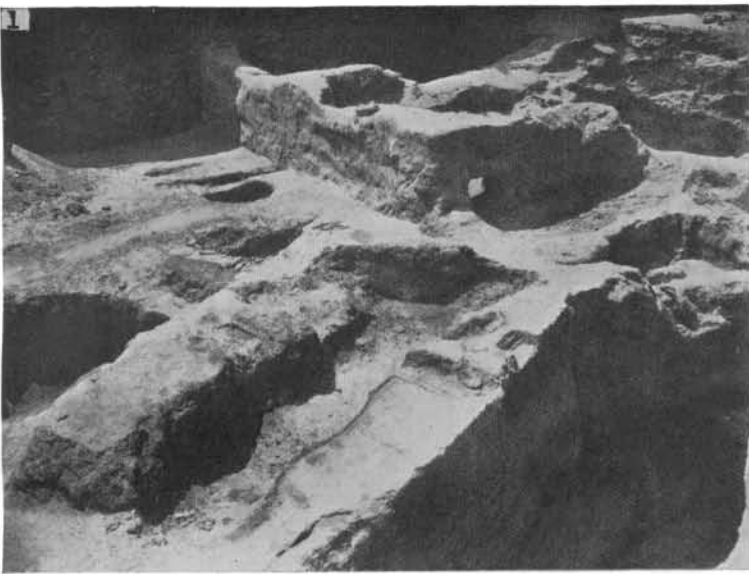

3 ZZ Lower seen from west

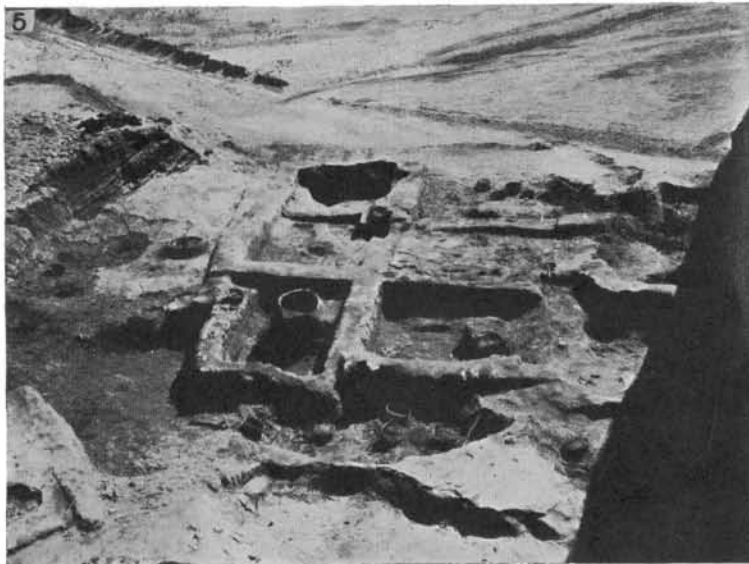
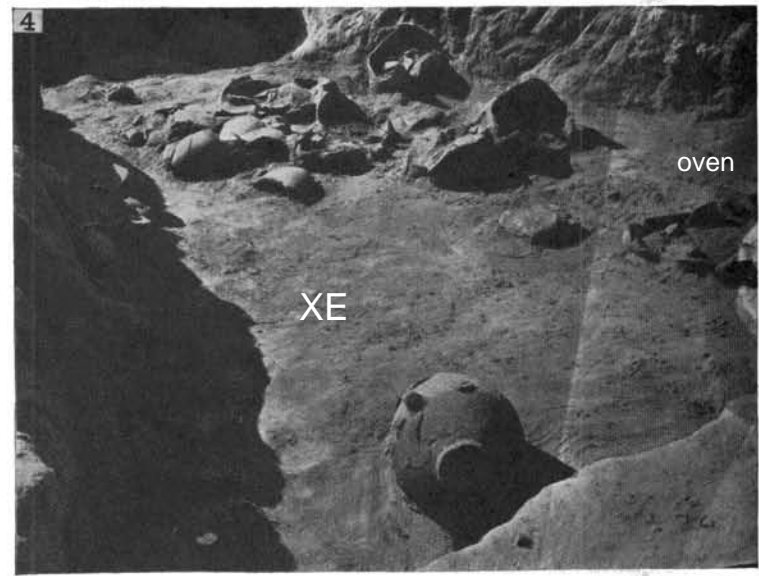

ZZ lower seen from west

from Stratum X

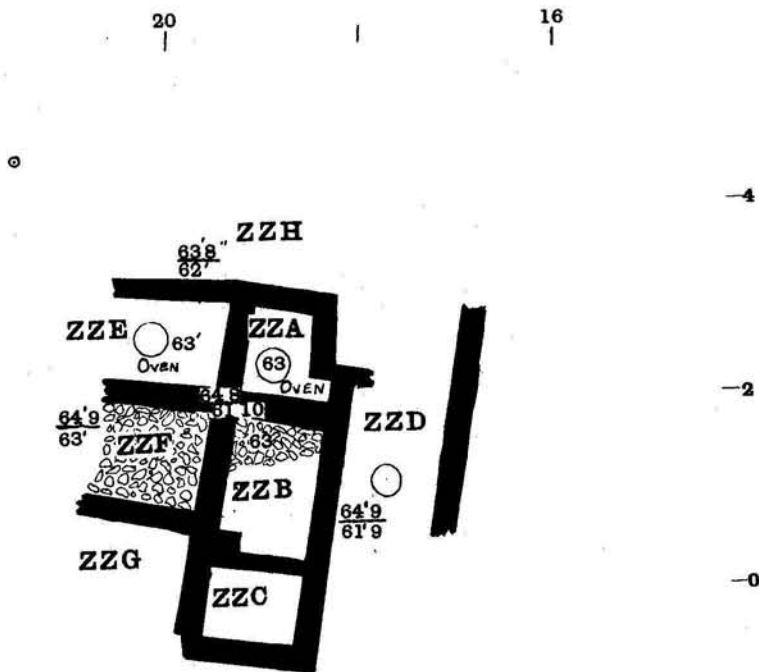
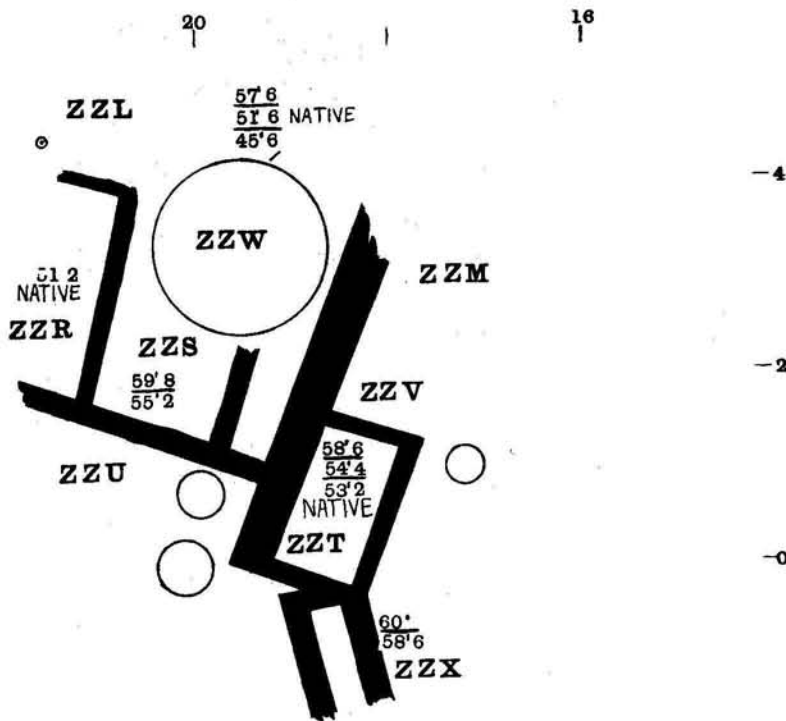



BETH-PELET. NORTH END: XIX DYNASTY RESIDENCY.



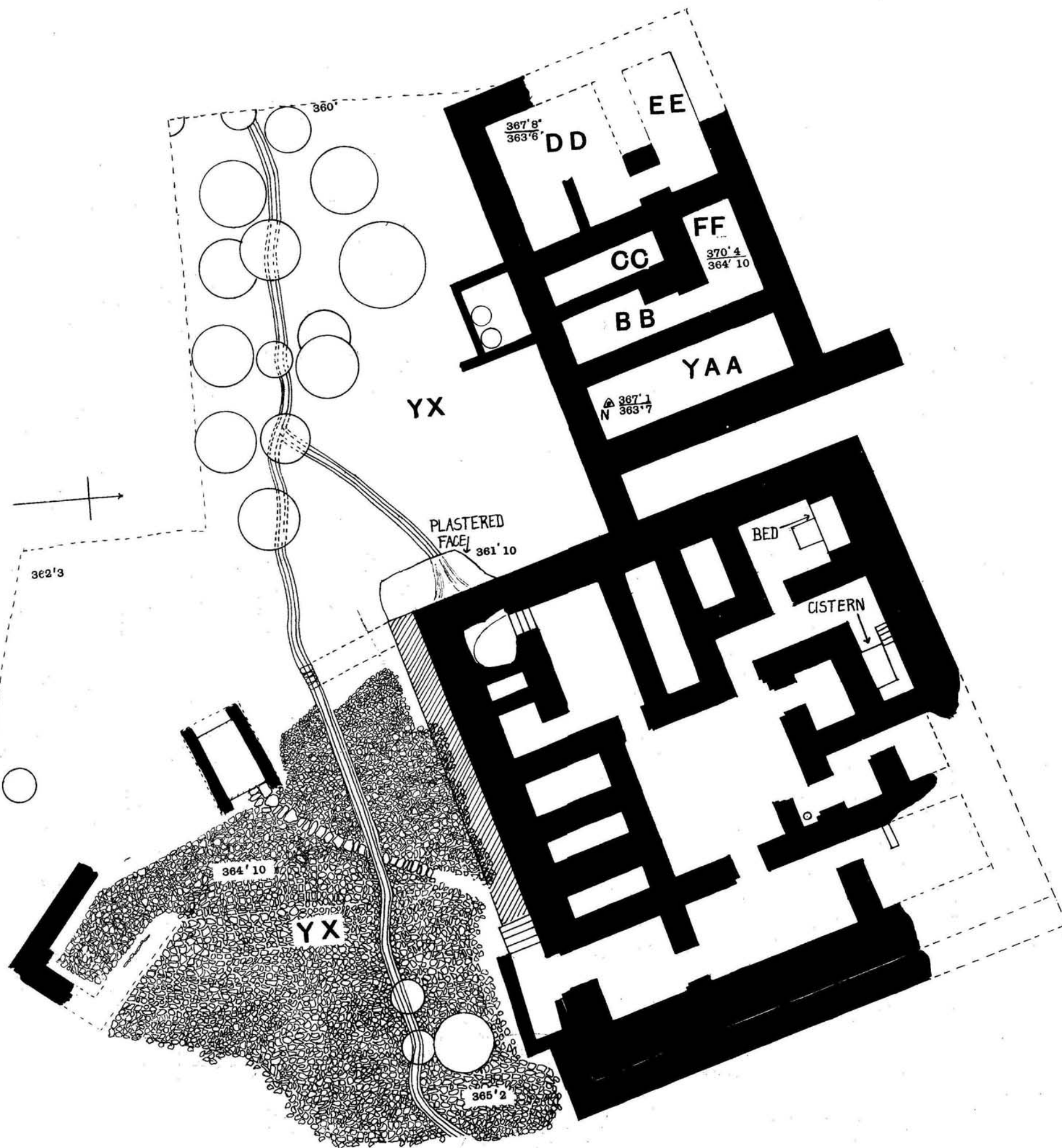

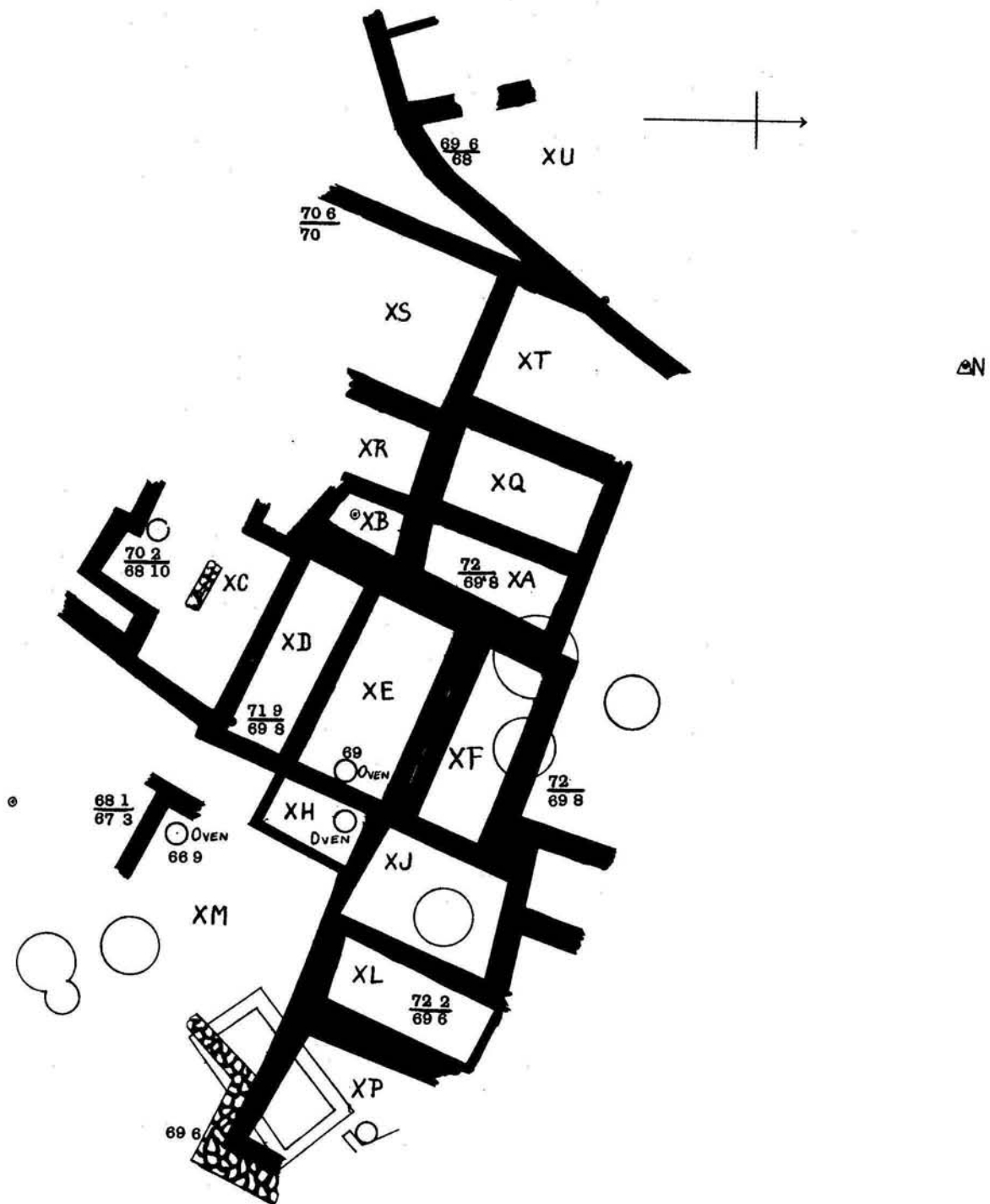

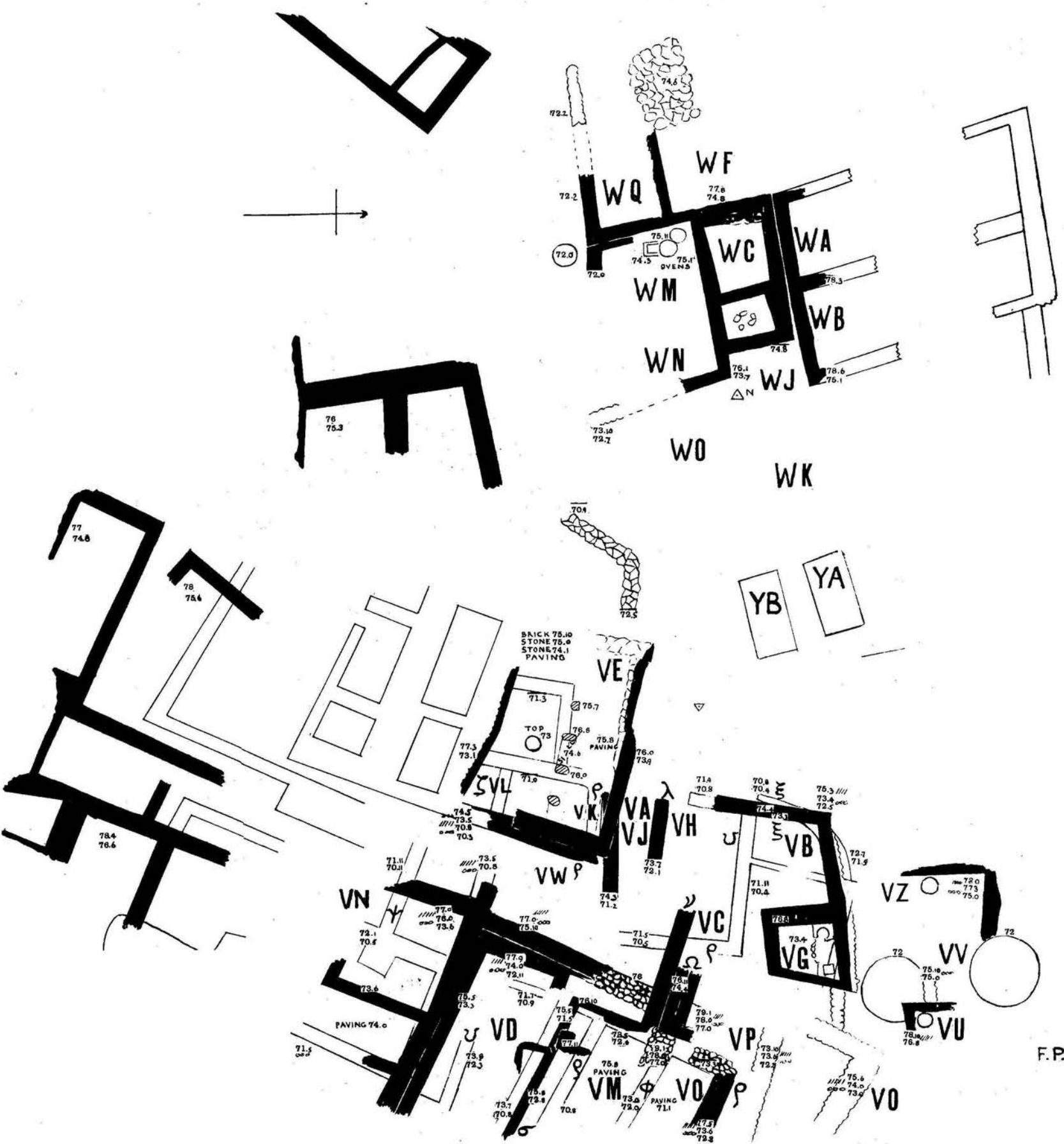

Group	TOMB	MAT.	DATE	Group	TOMB	MAT.	DATE	Group	TOMB	MAT.	DATE	Group	TOMB	MAT.	DATE
B	1016	Pt.	XVII	F	905	Gs.	XIX	K	925	Gs.	XIX	P	925	Gs.	XIX
14				38	960	Gs.	XIX	13				24			
19	1002	Av.	XVI	G	936	Bone	XIX	28	936	Blue Glaze	XIX	56			
78	905	Pt.	XIX	10				37	1005	Bone	XVI	46			
79	914	Pt.	XIX	14	914	Gs.	XIX	60	925	Gs.	XIX	S	952	Pt.	XX
C	960	Gl. Pt.	XX	20	936	Pt.	XIX	74	960	Gs.	XX	50	936	Pt.	XX
25				24	936	Gs.	XIX	85	922	Car.	XIX	52	935	Pt.	XIX
53	914	Gs.	XIX	40	925	Gs.	XIX	L	922	Car.	XIX	63	1005	Gs.	XVI
D	914	Gs.	XIX	H	914	Car.	XIX	88	922	Car.	XIX	V	960	Car.	XX
3				10	947	Gs.	XX	20	905	Pt.	XIX	11	960	Car.	XX
6	914	Car.	XIX	90	1021	Av.	XV	M	1008	Gl. Quartz.	XVI	12	929	Car.	XX
61	1008	Car.	XVI	J	933	Bk. Quartz. Chalcedony.	XX	64	1019	Gl. Quartz.	XVI	W	906	Bone	XX
135	914	Car.	XIX	14	931	Jasper	XIX	123	925	Car.	XIX	26			
E	960	Felspar	XX	90				171							
12															

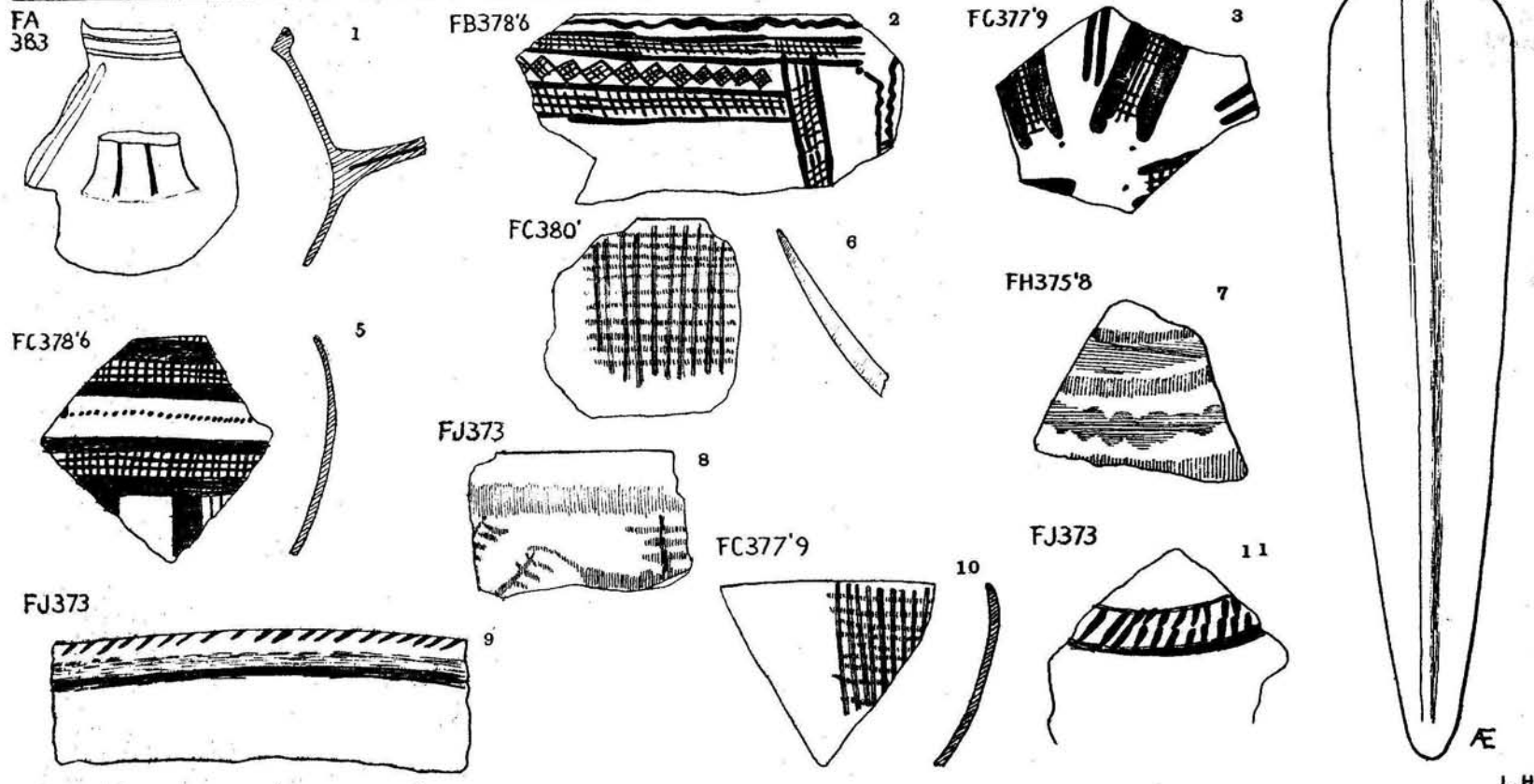

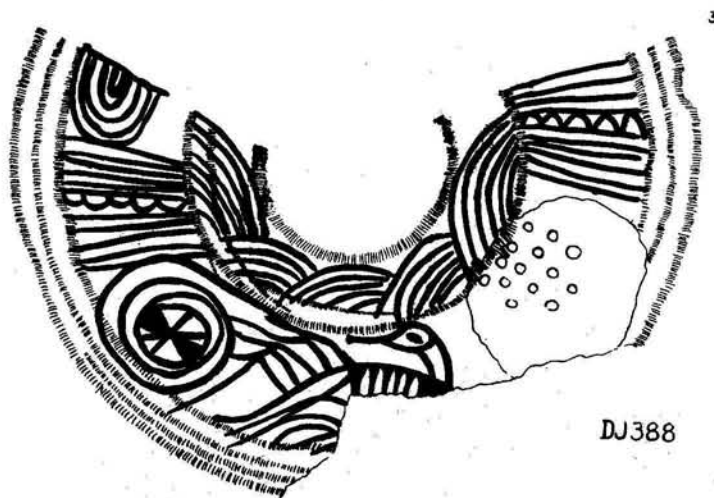
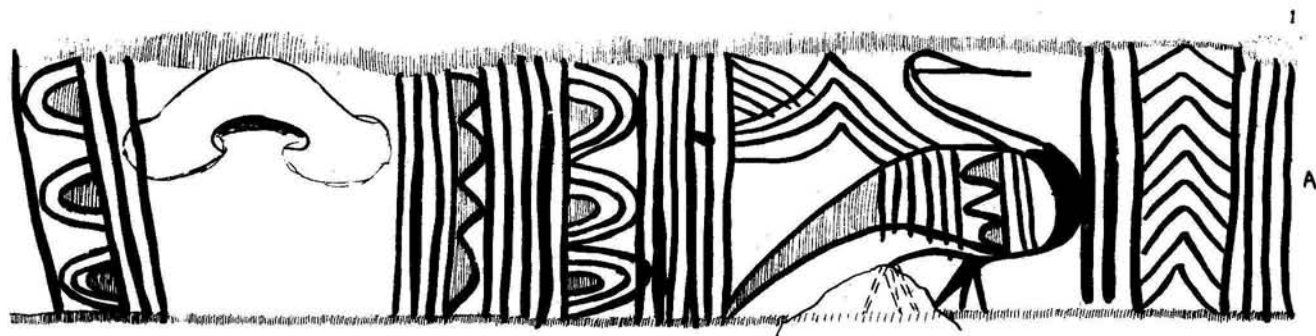

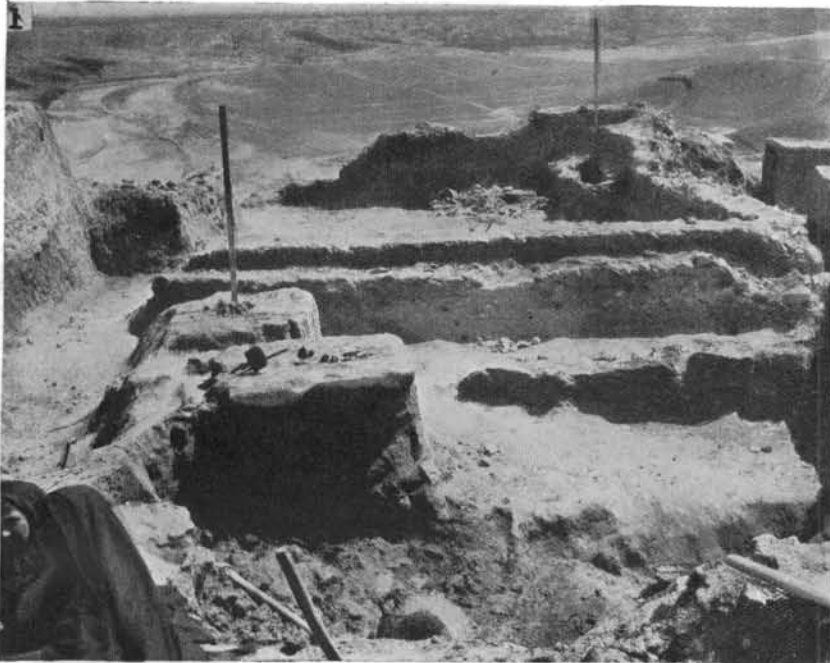

HYKSOS GATEWAY.



BUILDING OF GREEK PERIOD.

HYKSOS GATEWAY.

XIX DYNASTY.



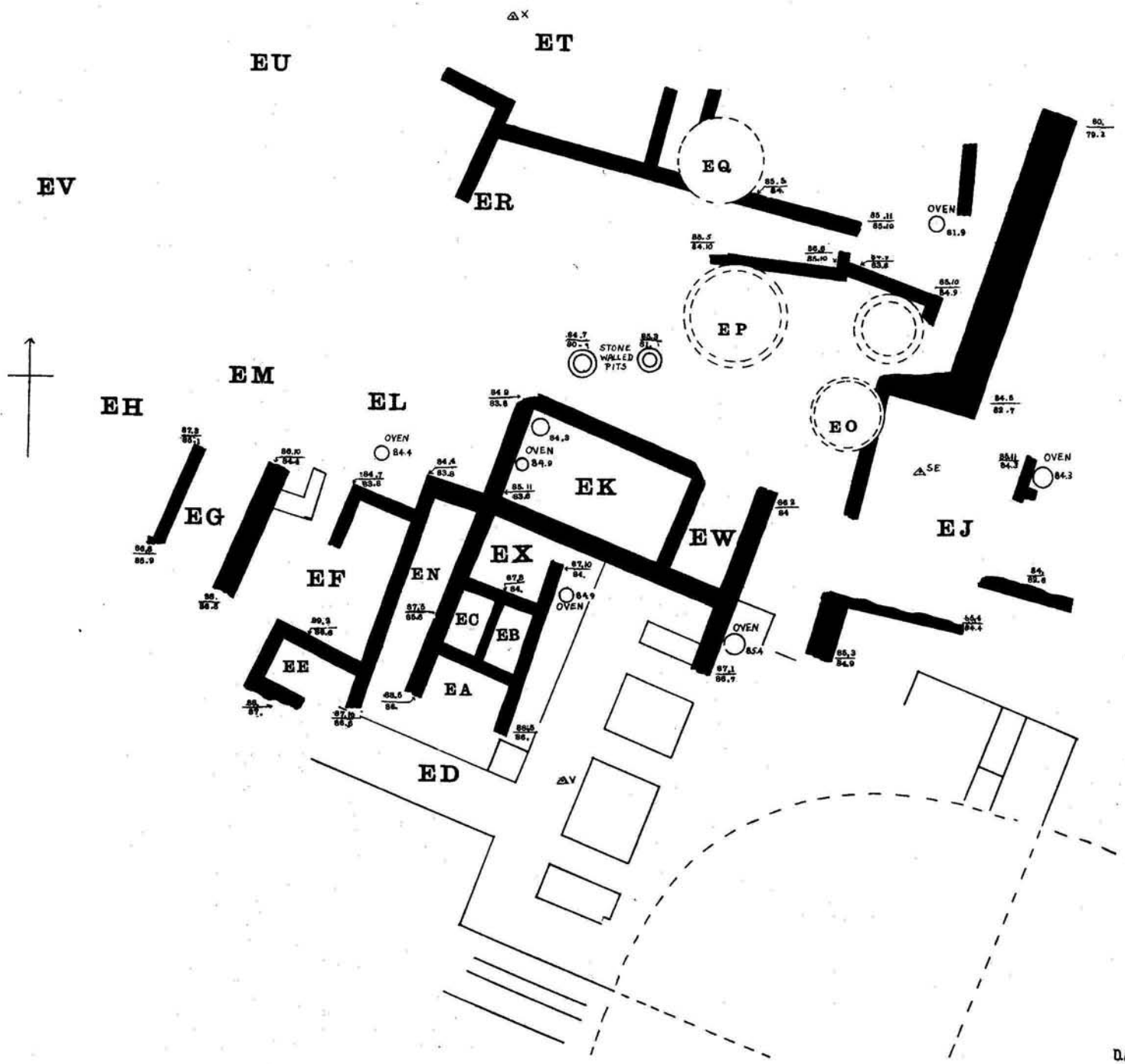

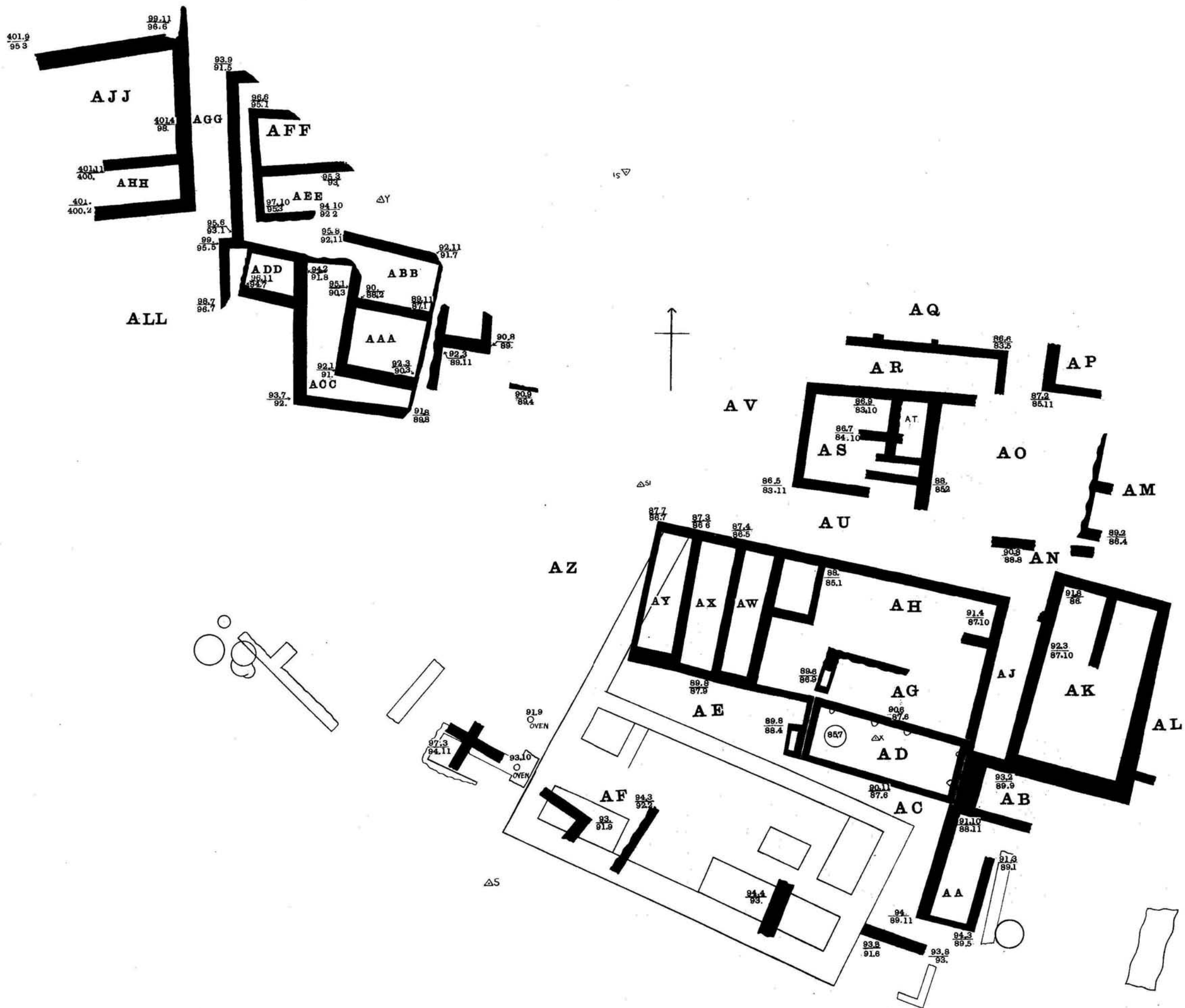

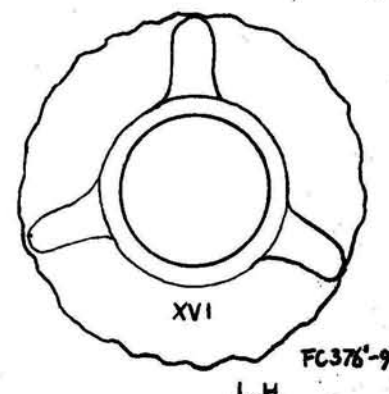
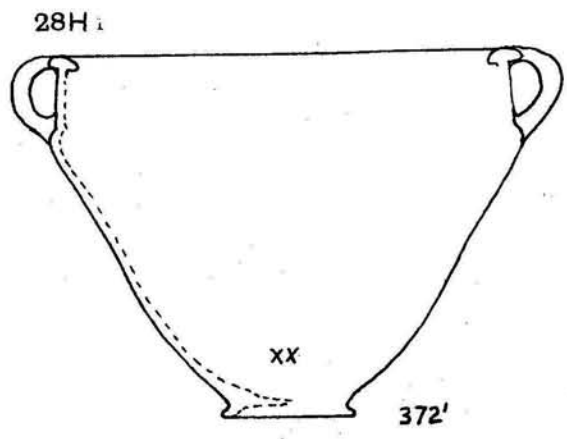
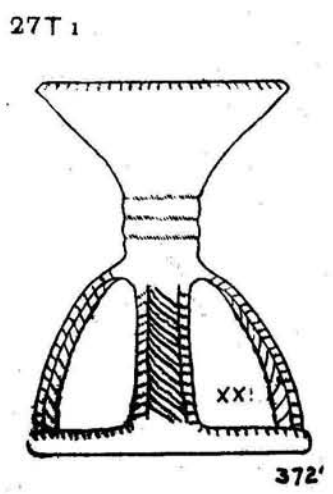
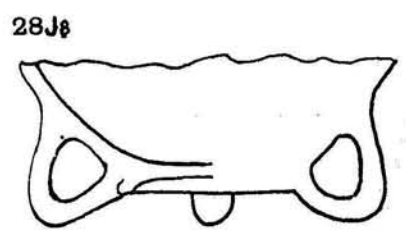
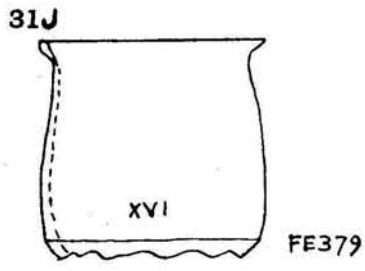
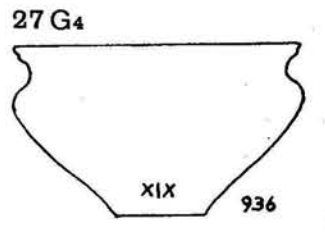
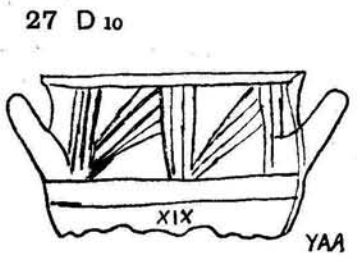
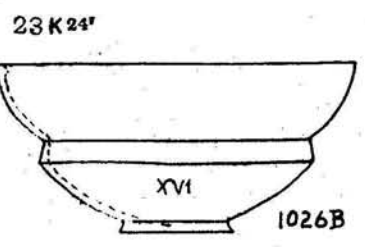
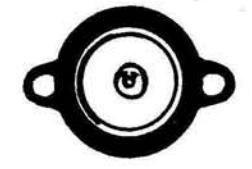
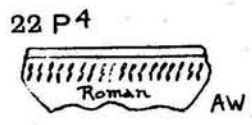
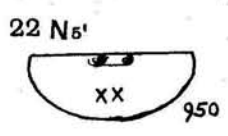
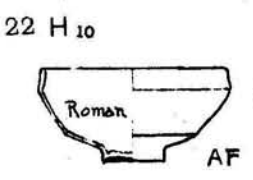
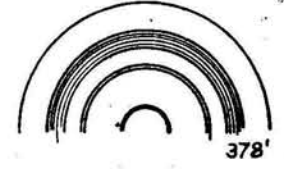
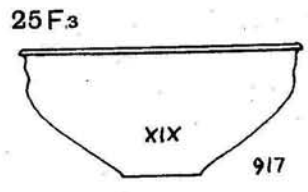
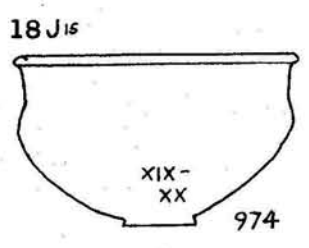
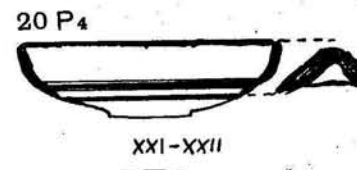
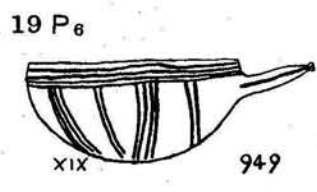
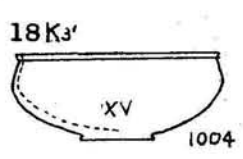
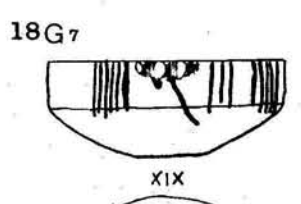
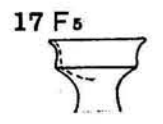
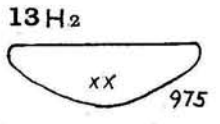
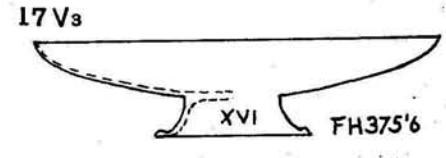
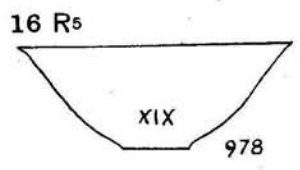
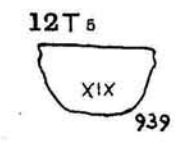
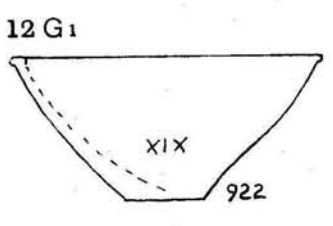
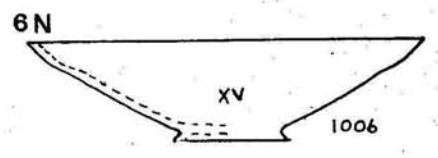
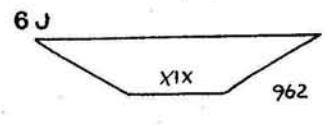
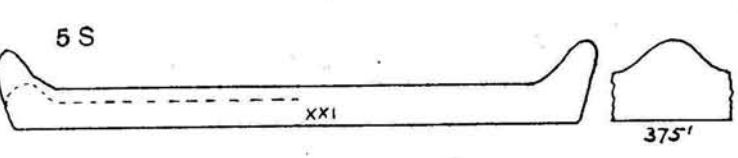

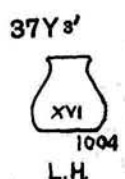
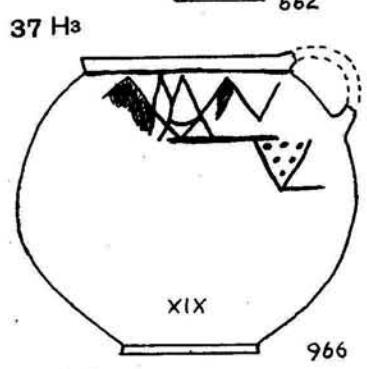
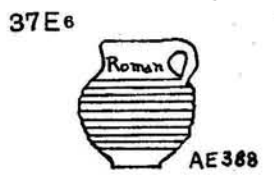
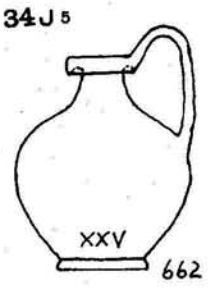
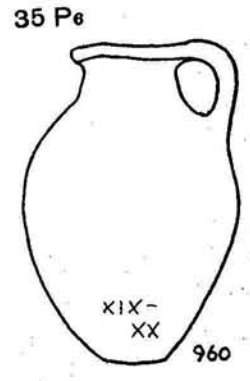
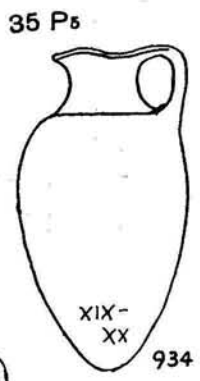
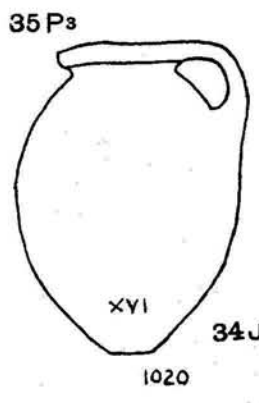
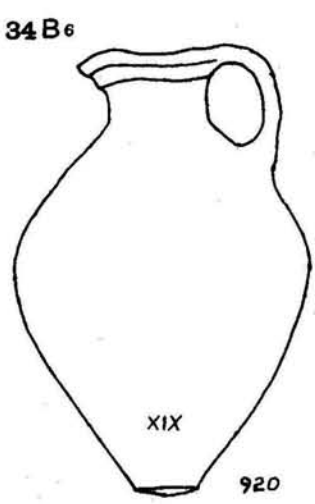
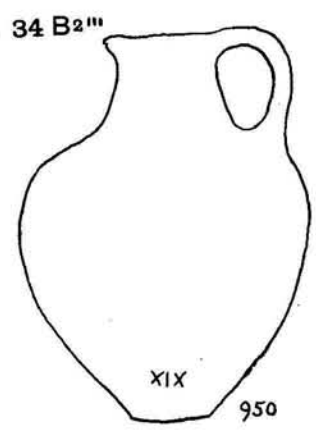
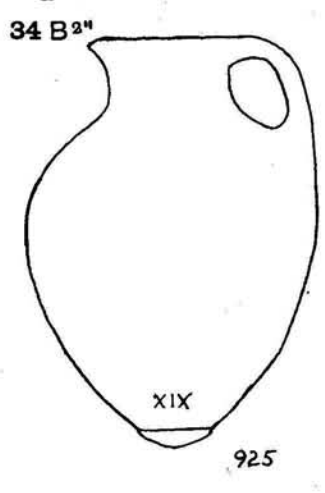
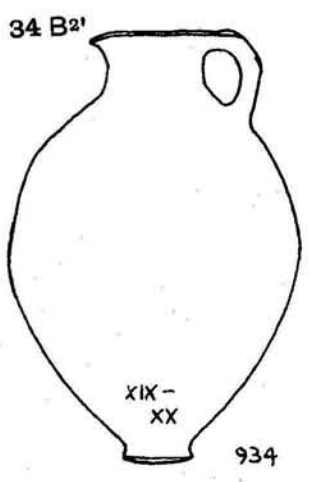
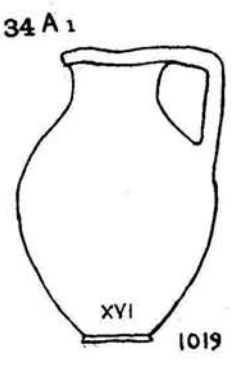
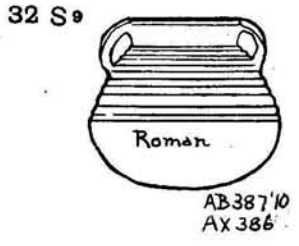
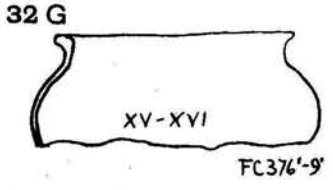
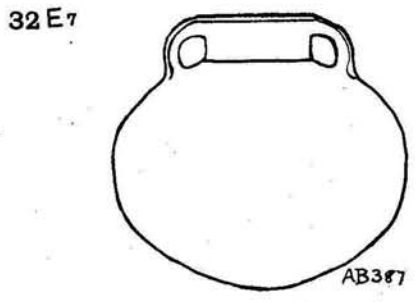
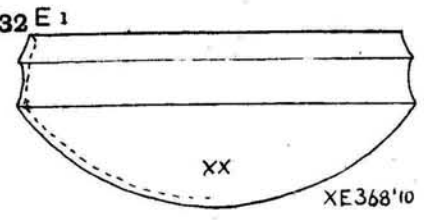

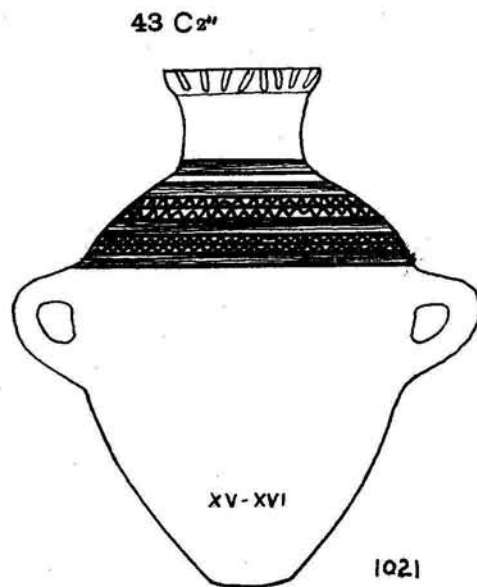
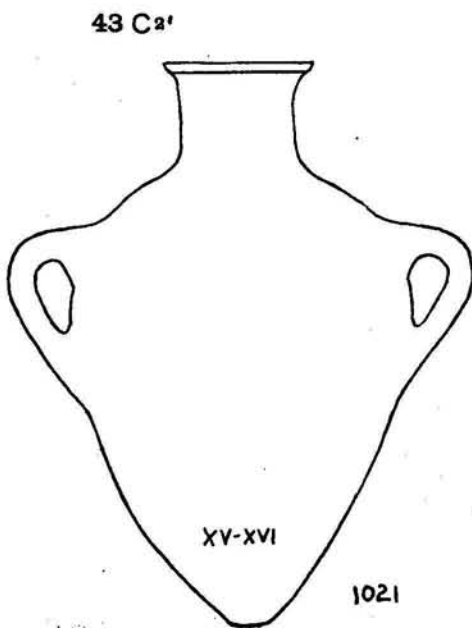
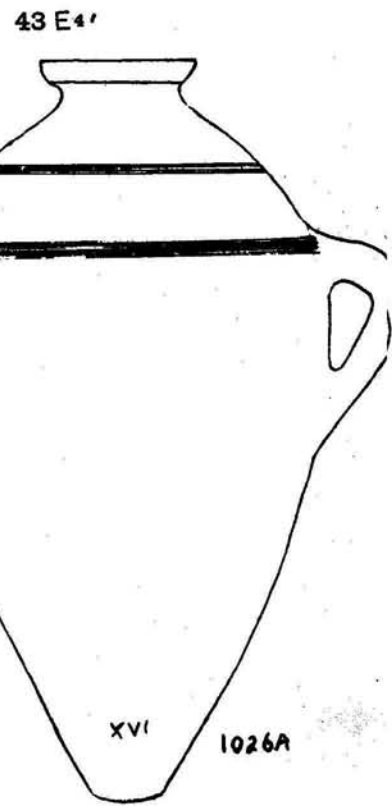
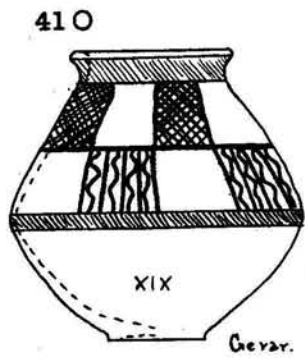
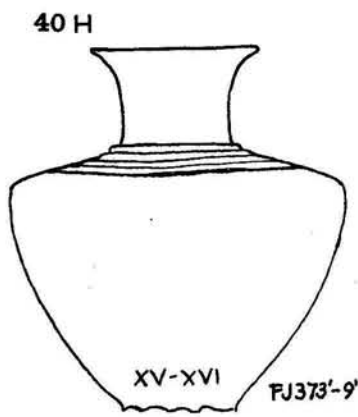
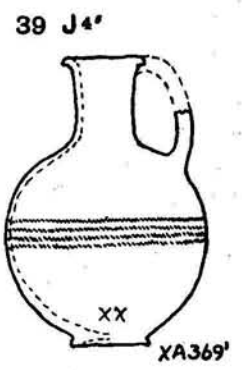
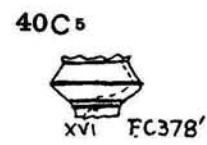
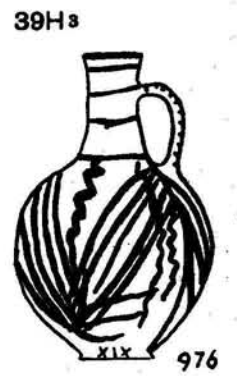
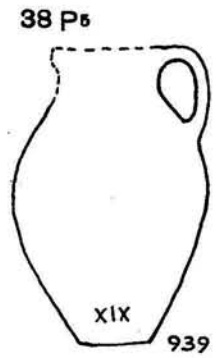
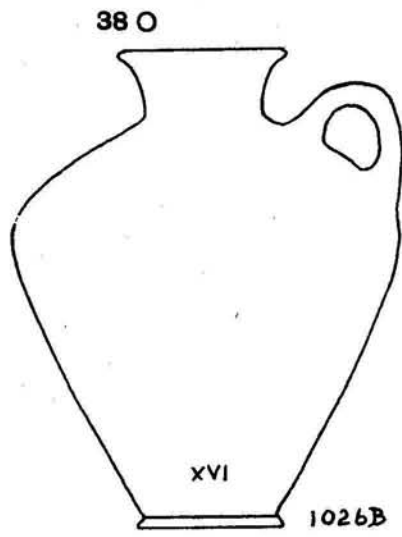
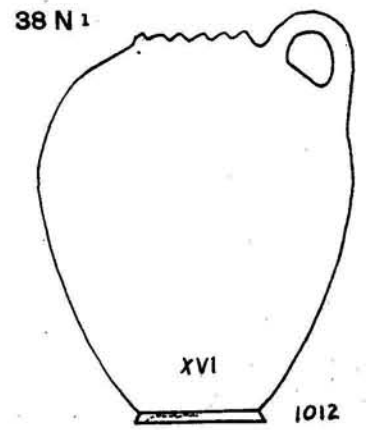
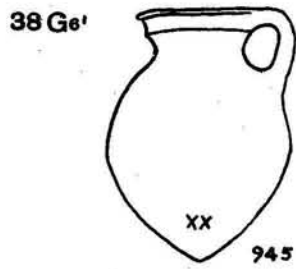
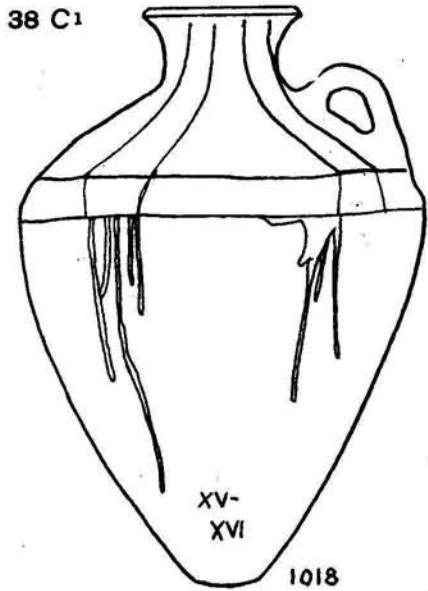

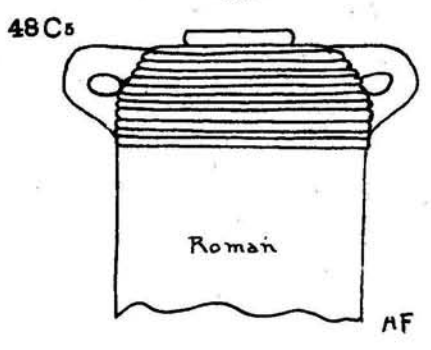
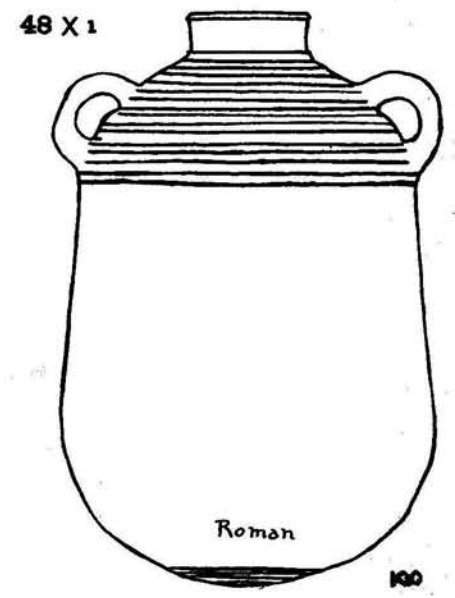
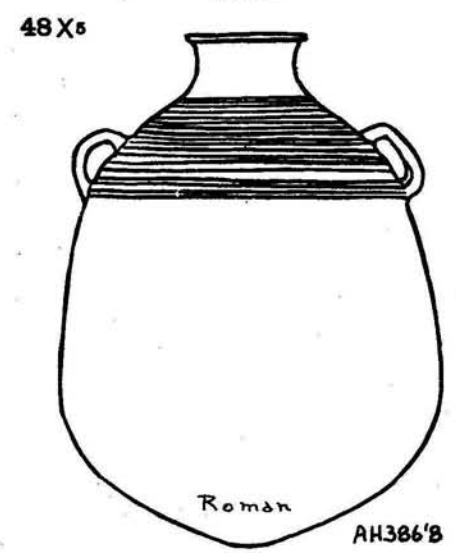
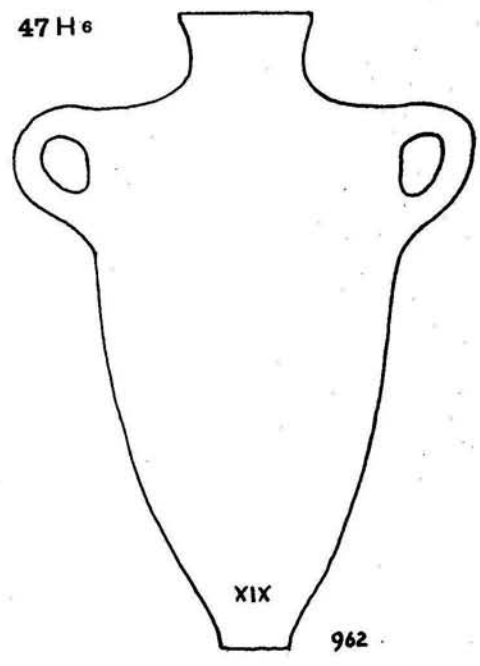
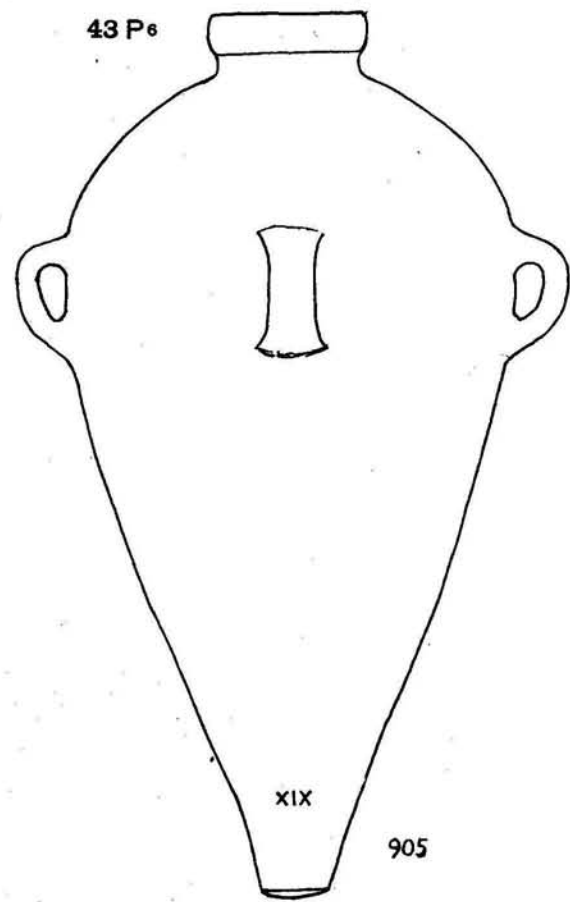
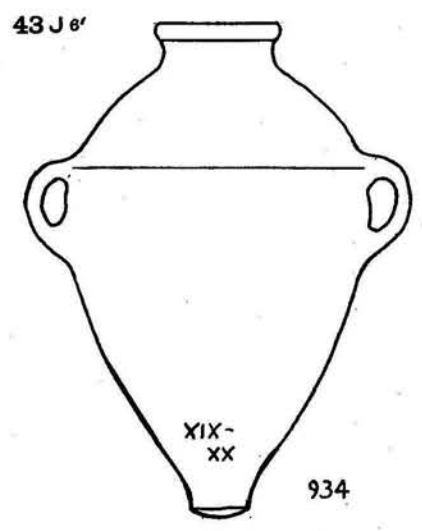
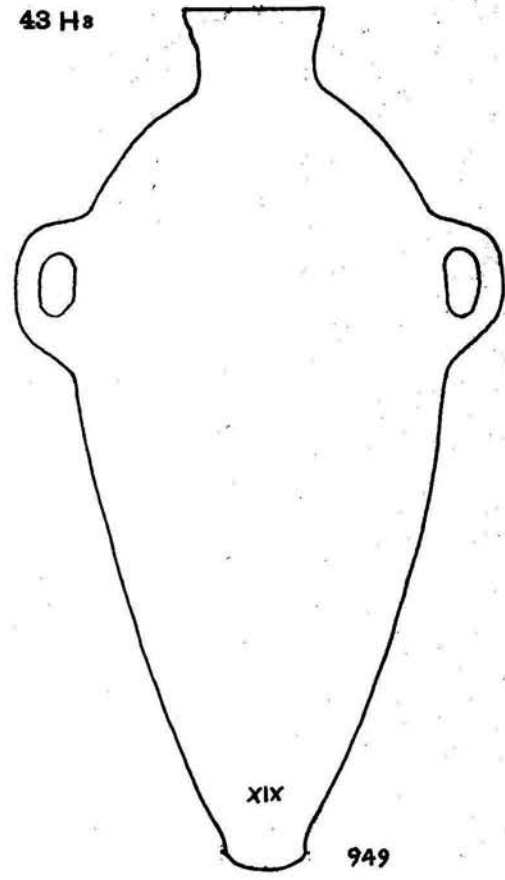
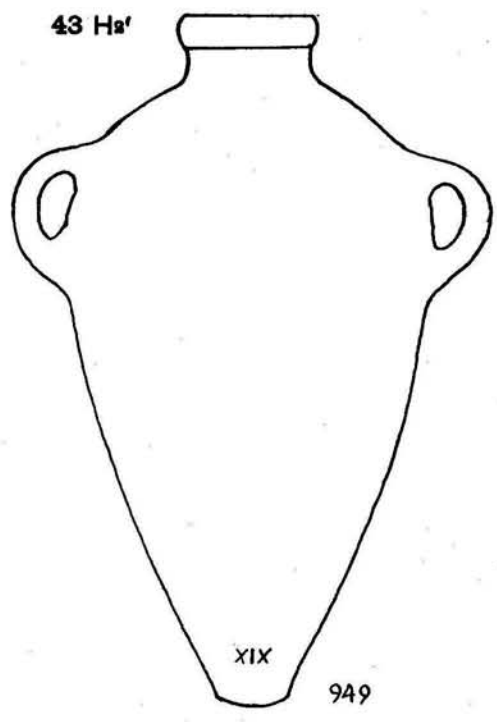
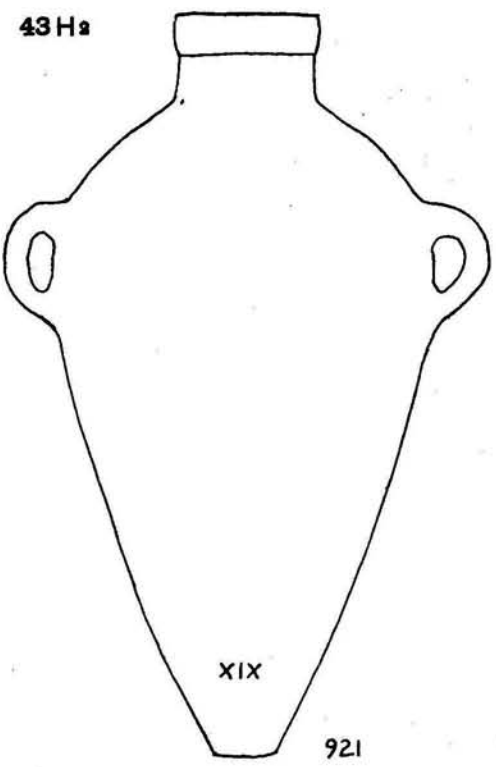

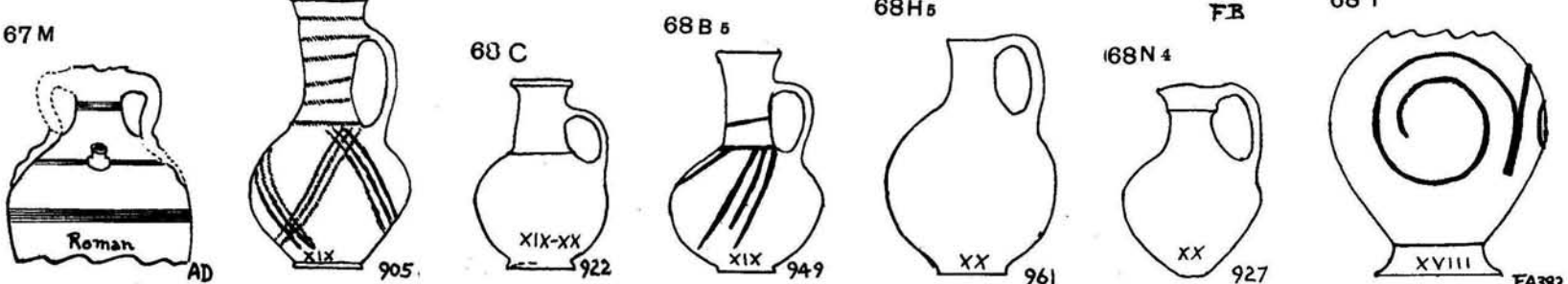
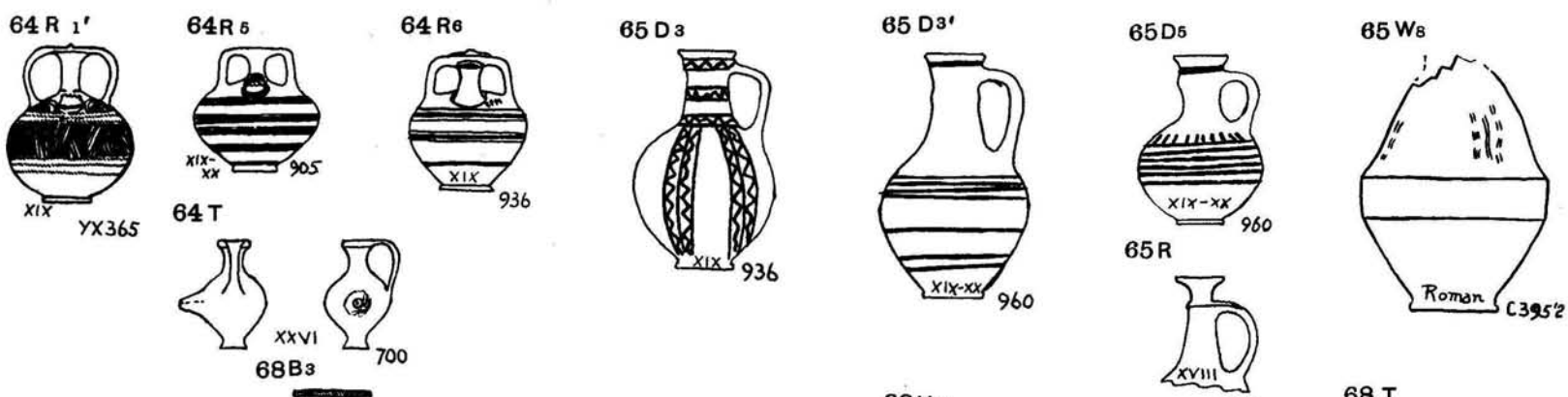
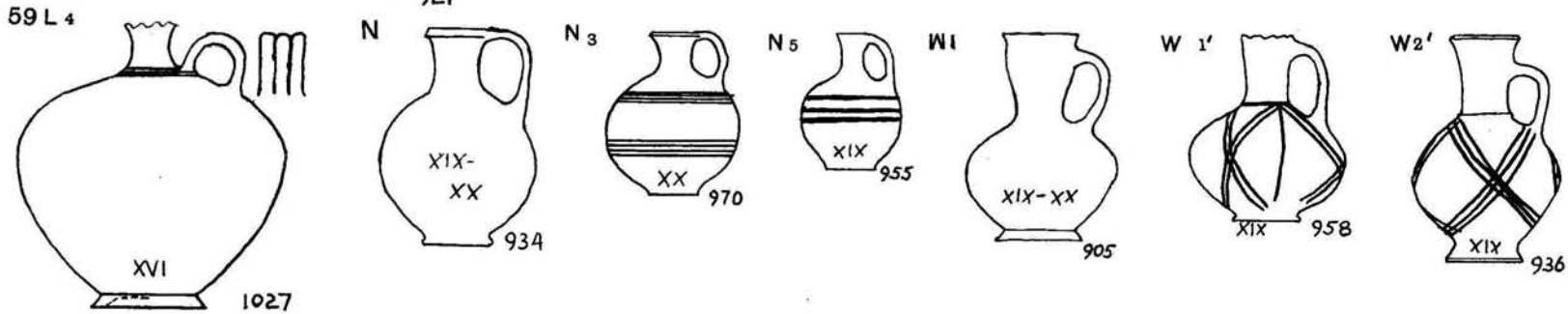
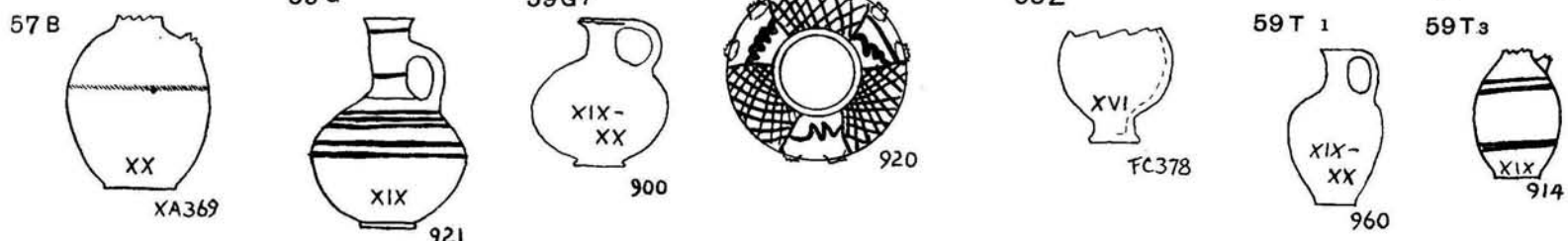
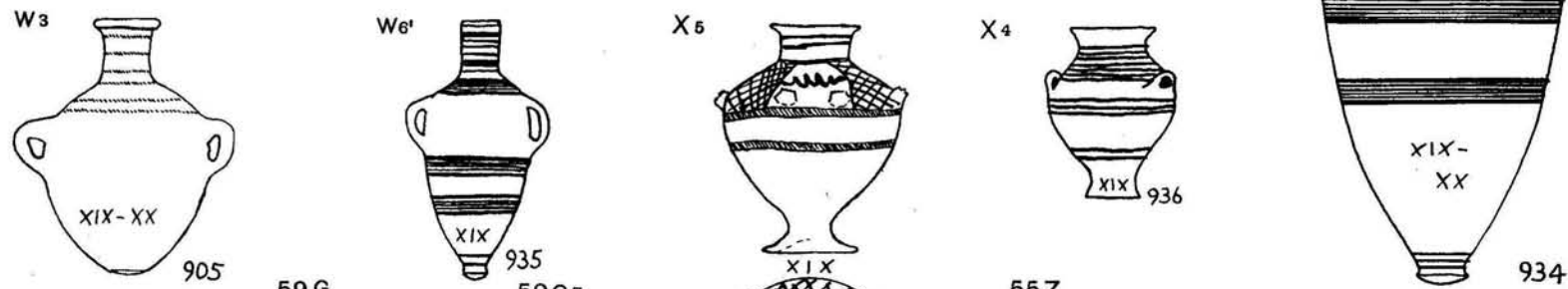
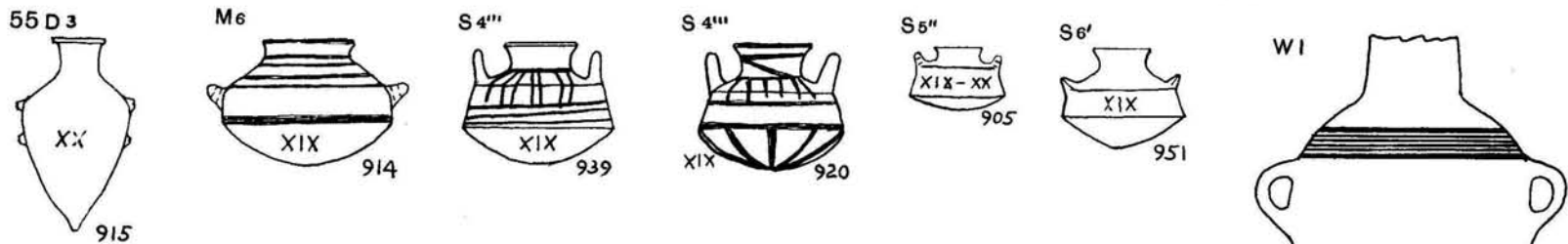
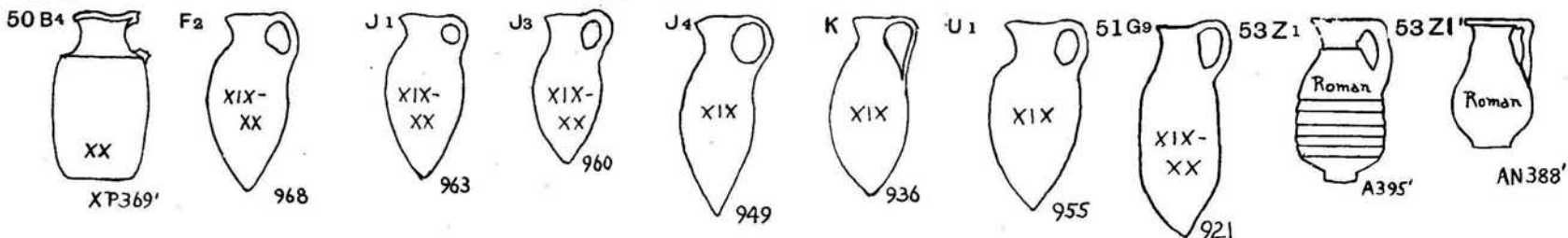

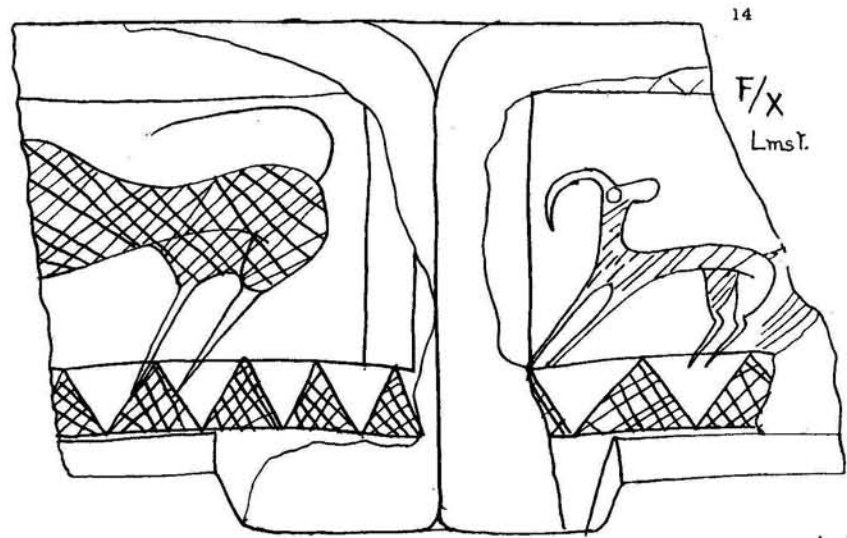
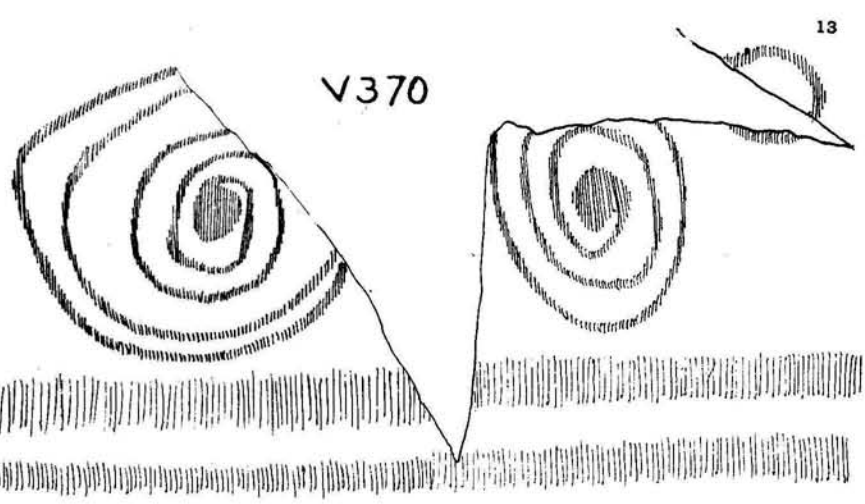
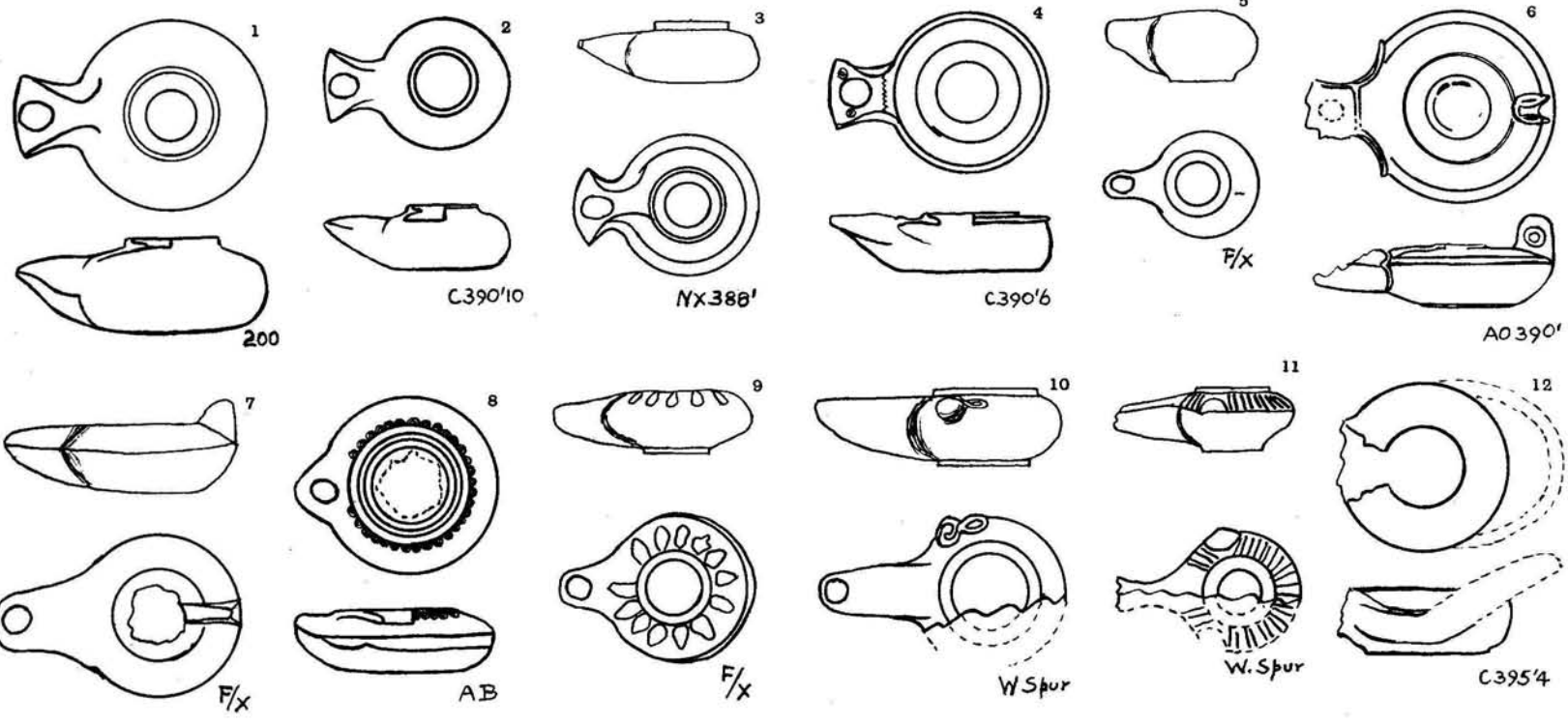
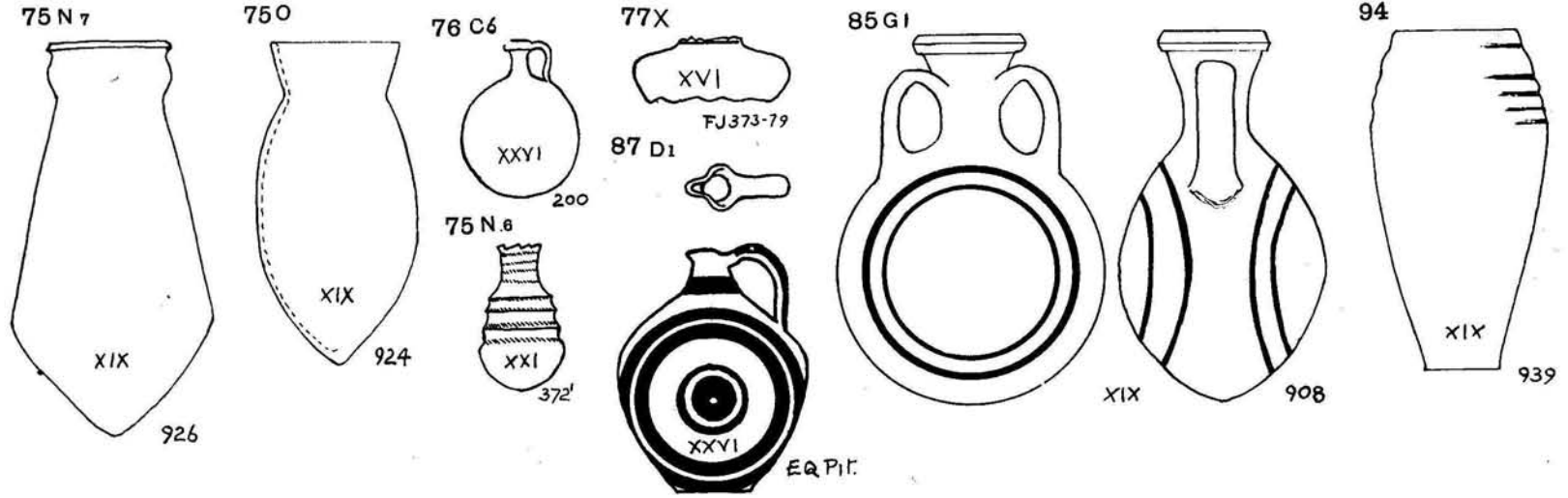
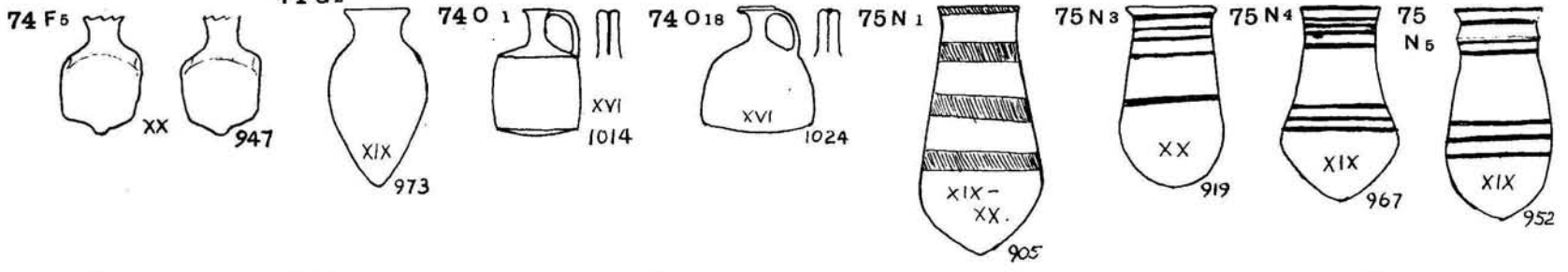

BETH PELET. REGISTER OF POTTERY TYPES, FROM CITY.

LXXXIX

ROOM & LEVEL	4-6	10-12	13-15	16-18	19-21	22-24	25-27	28-30	31-32	33-34	35-36	37-39	40-42	43-44	46-47	50-51	52-53	55-57	59-60	61-63	64-65	67-68	69-73	74-77	82-83	85-86	87-90	91-100																
ZZS356.4	6C C4			18J3	21B	23E4 K19	26C																																					
ZZR356.8	4E			18J13 K1																																								
ZZU357.8					21B																																							
ZZT359.6	6C3			18J10		23E1 K16	27H1	28B1																																				
ZZG360.6				18J14 V3		22N5	25G1 27G																																					
ZZA362.10	6F K	12M		16R4																								85U4																
ZZG363.10	6H	12H M N2					27M																																					
Z360-362				18P6		25O1							42E		46P2 47H														5352															
YX364.10	6F	12N6 T	15M6	18J14 V1		22C2 23B4 D	25E2 E1 H1 27D4 D8 B3	28D2 X6 29Q			36B3		42C	43H1 J4 J9												64R1 R1		85H5 OS																
YX361.	6H	12N8		18J14		22E1 23C4 J14 X	25E1 E3 J 27B3	28B2 W1 X2						43J4 H1														50Q	74N															
YAA364-70.						23K18	27D10																																					
YGRAIN PITA				16M3		25E1 M3 26B2							35E		43H3	46P2													83B2															
Y366-368.						23B1 24S1	25F 27D4 D8 M	28B2 D2						35E 36P																37R2														
XA369.10				17E4											36M7	39J4														43J6 J8	5554 57B	85R7												
XE369-71.						22NS	25E2	28Y3																						32E1 Q2	42C													
XM370-72.				18V1		23B1 T2	25E3 27M																								59J2													
XP370-72.					20P	23J12	25E1 E3 27D7	28B																							37R2	50N1	52M1	85O1										
X369-72.				18F3 T V6 V1		22B2 N2 23B1 K4 U	24S1 25E3 T	28C H1 M1 Y2						34F5	37E3																43K4 R2	46D1	53R	62C3	64C6	85E9 H6	91J4V							
WC						25V1	28B																										67											
WH370.5	4V			16F																													43Q2											
WN370.5	3N			14C	18D3																																							
WK370.6				14R	18J2		23U																																					
WAC370.11							23N	24T																																				
WZ371.11							23F	24Q																																				
WP371-72.					18J2			28Y2																										43R2										
WS372.				14K																														46D1										
WAE373.4				16K			27M																											34B2										
WAD						22P5	23R1	25T																																				
V373-77.	4V			14R		16P 17E4 18E3 E6 K5	20B2 21X	23V1 P2	25F2 27M	28C	31C	34V	37M4	42A	43J7 K5																				52M1	55S8	67S	82E 83B2 85O CI	91G4					
TM374.3	4V																																		44R6	83B2								
TN376.4				18E4			23D																																					
TV377.				17P5			23P2	24G1																																				
TP378.							23V1	24J	28B5	31J																										47Y	86P	91M2						
TN380.				15N4		21B																														47H	65D	85P1						
T378-81.	4V			15N4	18E4		22T1	25M3																												42C	48S	86B	91N					
R382.																																				32D3	46P2	47K						
FAJ373-79.	6C4	12V3		18J7 J12	21B	23K6	26G5																														40H	77X	91A1 A2					
FAJ376-79.	4E J	10E2 L2 M4	13T	16K S4 K1	19P2	23K22	25D1	28J8																															31J 32G	40C5	51G14	55Z	74O23	91A1 A2
FA383-84.				10P2		19C																																	68T					
FBP.T						19B3																																	68R					
AA385-88.																																							32E7 S9	37X5	47U5 48X5	67M		
AE388-90.						22P																																	36G4	37E6	47O7	53Z1 Z1	65W8	
EQP.T						20J																																			87D			

E N D

N O R T H

S O U T H
E N D

L.H.

BETH PELET. REGISTER OF 1,000 CEMETERY.

XC

TOMB	CHAMBER N E D	BODY H F	AZIMUTH	DATE	POTTERY	BEADS	SCARABS	METAL	VARIOUS	PLATE
1001	74 36 38		259		23K6 43E4 51G11 74020					
1002	Plan Pl. XLV		281		21B1 43D2 51G8 74020 D5 G11 D6	B19 A'	2, Pl. XLII	Æ Toggle	Frag. Bone Inlay & Ostrich Egg Shell	XLII XLIV
1003	101 41 44		269		38B2 43E4 74011, 021			Æ Toggle		XLIV XLII XLIII
1004	Shallow Pit				18K3' 37Y3'			Æ Toggles	Alabaster Vases	
1005	85 68 86	W N	285	XXVI		D80.0. L53Am H49. " 66G. K37 Bo. N89C. L23Cv. S63G. 45C. T21 " 26Am 42 "	1 Paste	A' Earrings		
1006	94 32 43		274	S 6N	23C1 25D1 43A2 51G14 74020 K7 E5	91A3	1 Gr. Feldspar	Æ Dagger	Basalt Bowl	XLII XLIV
1007	72 39 43		252		21B 23K19 43A2 51G14 E4		1, Pl. XLII	Æ Dagger		XLII XLIV
1008	60 37 52		295		25G1 43C1 51G11 74021 D4	D61C J54Am B3Am N50Cv J38C 64CQ	1, Pl. XLII	Æ Toggle		"
1009	72 70 66		293	O	18J1 43E5 51G11 74015 F3 G12					
1010	84 24 38		279		43F3		1, Pl. XLIII	Æ Ring Æ Toggles		XLIV
1011	33 84 39	N W	182		18J3 43A2 51G14 74015 C8 E4		1, Pl. XLII			
1012	67 20 34		276	S	16Z5 18J4 38N1 43E5 51G8		1, Pl. XLIII	Æ Ring Æ Earrings		XLIV
1013	81 52 28		285		18J8 38B4 51G7 7402 91A1 K2 N			Æ Toggle	Glozed Dipper Flask	XLIV
1014	41 18 23		261		38N 7401', 015 91A1					
1015	60 28 42		174	K		L15 Carn.		Æ Toggle, Ring & Bracelets		XLIV XLIII
1016	76 54 43	N	303			74021 91A1 B14 Paste	1, Pl. XLII	do.		
1017	44 17 64	E N	300		15H7 18J14 23K19 38B2 51G13 74015 91A1		1, Pl. XLII			
1018	Plan Pl. XLV	N W	157		18J11 23K6 38C1 43A4 51G11 74011 91A3 K17		4, Pl. XLII	Æ Dagger Æ Toggles	Æ & Ivory Dagger Handle	XLIII
1019	do.		179	Y	18J11 34A1 38B1 51G3 74014	M23C1 Quartz	2, Pl. XLII	Æ Toggle		XLIV XLIV
1019A	do.		179				1, Pl. XLII			
1020	do.		187		10M4 21M, 23K14 35P3 43F3 51G11 7408, 015					
1021	do.		79	H	10E2 18J6 23E1 3802 43C2 51G3 74011 12 2' 5" 13 2" 11" P2 E5 14" F3	H90A N87C. J70C 98" L26" 129" 40" 159P 58" T10C	6, Pl. XLII 3 Gr. Jasper 1 Amethyst	Æ Toggles Æ Dagger Æ Ring	Decorated Ostrich Egg	XLIII
1022	96 53 68		180	Roman				Æ Box Lid	Glass Vase (Frag.)	
1023	Shallow Pit			S	18J12 43D6 51G E4 G13					
1024	Plan Pl. XLV		177	S	23D 38B4 74015, 018		1 Amethyst	Æ Toggle	Frag. Bone Inlay	XLIV
1025	60 22 30		313		3802 7401 91A1					
1026A	Plan Pl. XLV		267	K	35P4 43C2', E4'		5, Pl. XLII 1 Amethyst	Æ Toggles		XLIV
1026B	do.			Y	23K24' 380 43E6		1, Pl.	Æ Toggle	Frag. Bone Inlay	
1027	Shallow Pit			H	21B1 59L4		1, Pl. XLII	Æ Toggle		XLIV
662				XXV	34J5				Limestone Incense Altar	XCIII
663		N Up		XXIII	22F, 23B1 43J6 50G1			Æ Spear Head		LXII

L.H.

BETH PELET. REGISTER OF 900 CEMETERY.

XCI

TOMB	N E D CHAMBER	H F BODY	AZI-MUTH	DATE	P O T T E R Y										SCARABS	METAL	VARIOUS	PLATE
905	Plan Pl.		60	XIX	6F 12H	21L1 22N5		43H1	50G3 52G2 55S4"	59W1 68B3	75N1 85E8	11 Stea.		Calcite Vase Pottery Rattle Paste Amulets L. nat. Spindle	XLVII XLVIII			
906	Over Entrance 905					23N 25H1							Æ Anklets					
907	14 63 54	N Up	146	XIX					55V									
908	14 43 42	N Up	144	XX	12L4	15U4			51G9		85G1							
909	24 68 28	N Up	146	XX	12H					59N1	85G1	1, in AB	bezel, Æ Ring		XLVIII			
910	12 64 42	S E	147	XX								1 Stea.			XLVIII			
911	17 77 36	S Up	146	XIX			34B3'											
912 913	No Tombs																	
914	Plan Pl. LIX		75	XIX-XX	6F 12N2	23J14		43H	50U	55M6 59T3	91C4	11 Stea.	2Æ Bowls Æ Spearhead Æ Strainer Æ Dagger & Charn	Calcite Vase Honing Stone Paste Amulets N/A R Earrings R Headband	XLVII XLVIII XLIX			
915		S Up		XIX					55D3		75N1		Æ Anklets	Paste Amulets	XLIX			
916	Child	N Up		XX					50U			1 Paste	Æ Anklets	Paste Amulets	L			
917	do			XIX			25F3					1 Stea.			L			
918		S Up		XIX					52G2		75N3			Paste Amulets				
919	Child	S Up		XIX	12H						75N3		Æ Anklet	Paste Amulets				
920	Plan Pl. LIX	E Up		XIX			34B6 37J		55S4' S4" X5			4 Paste	Æ Toe Ring Æ Kohl Stick Æ Earring	Paste Amulets	XLIX L			
921		N Up		XX	12L4	22N5		43H2		51G9' 59G	85G1 H10	3 & 1 Plaque			L			
922		S Up		XIX-XX	6F 12G1 L4					68C	85G1	B	A/ Finger Ring A/ Earrings		XLIX L			
923	Child	S		XX					59N1			1 Stea.			XLIX			
924	do	N		XIX							75O				L			
925		S Up		XX			34B2"				85L3	3 Stea.	Æ Earrings Æ Horn Amulets		XLIX XLIX XLIX			
926A		E Up		XX					59T		75N7 85G1	2 Paste			L			
926B				XX	12H		34B2"		59T			1 Paste			L			
927		S		XX				50J		68N4		2 Stea.	Æ Anklets Æ Earrings		L			
928	Child	S E		XIX	12R			50J				2 Stea.			L			
929		N E		XIX	12R			50U					Æ Earrings	Paste Amulets	XLIX			
930	Child	W		XX								1 Stea.		Paste Amulets	L			
931	do	S Up		XIX							75N1	2 Stea.	Æ Ring		L			
932	do	S N		XX										Paste Amulets				
933	do	S Up		XIX	12V3						85E6			do.				
934	Plan Pl. LIX		95		12H		34B2' 35P5	43J6' P6	50G2 55W1		85J13	95 Stea. 11 Paste 29 Carr. & Am 1 Cylinder Seal 6 Plaques	Æ Rings & Earrings R do. Figs. R Pins A/ Ring, Beads, Earrings.	A/ Horns Amulet A/ Headband Paste Amulets Pottery Rattle	L LII LIII			

	A	B-C	D	E-F	G	H	J-K	L	M	N	O-P	Q-R	S-T	U-V	W-X	Y-Z
905		B78G 80P	105G 148G	F 33C 40C				90 Y.L.	20P	32G 139C 87C 148P 104G 152P 135G 170P		R81 86 B.G1.		X50G	Y24G	
906	41H	B46B.P.								78C 95H 168 Y&X.P.		R83 P		W26Bo.	Y10R.P.	
910			15G 62Q													
914	28A 66C 68C	D46B.P. C35E 33G	3C 93C 4C 135C 15C 142G 76C 150C 85C		14G 16C 20C		J62C 93R 72G 97R	53C 58C		150 B.G1. 172 B.G1. 175 B.P.				V10R 21C 13C 24C 20C	Y6 P	
915						16Se 26Se. 32L										
916							J97 P	98C		135 G						
919	68C		89G 114G							170 B.G1.						
920	16R.G.						J97 G	74Y 94G		87Q 135G 96G 141C 124C 160YL 133Bd.	P54 P					
922			150 C 152 C	F37G			J70G 95R 88C 97R 93M	47C 85Bd 53R 88P 76C 90C 47C 68 C 70YL		55 G 137 R 80 C 157 C 104 G 168 P 122 G 175 P			V 12 C 13 C 14 C			
925					10G	J93R 97R	K13G 60G			171N 175B.P	P24G					
926A			39C 60WL					47C 62C		52 P						
929							J93 C	42C 62 G 47C 68 C 35C		152 P 162 BkG			V 12C 15C 14C 24C	X80 BkG W4G.		
930	66C		93C				J90 J	74C 117J		89G 170C						
931	60C		150 G				J54 G 56 G	K7B C		162BAW/P						
932			96G				J14 CAABKQ	72 C								
933						39 Se.										
934	14C 50C 35C 63C		5C 83C 6C 114C 12P 134P 15J 142C	F10C 20C	G24G	H10CKISP 16L 40P	J14CA 62C 33C 72C 48H 80C 54C	40C 94C 42C 95C 53C 97C 58Y 100C 72C 102Y 70Y 106Y 88C 110C 90G		15C 119 C 44V 122 G 48J 133 G 80C 135 G 68C 139 P 73P 150 P 88C 170 P 104C 175 P	P34 P 52 P	R83P 86B.G1.	U 32 C	V 10 J 13 C 14 C 15 C 24C	Y6B.G1 Z14 C	

TOMB	N E D CHAMBER	BODY H F	AZI-MUTH	DATE	P O T T E R Y										SCARABS	METAL	VARIOUS	PLATE
935	Plan Pl.		87	XIX-XX	12M	26C			50G2	55S4'	59T	85L8	9K3'	29 Stea. 4 Carn. 1 Plague	A/Plague & Earrings R&E Rings E Bangles	Fragr Pottery Coffin E Kohl Stick	LIII	
936	Plan Pl. LIX		85	XIX-XX	6H 12K 17F5 V3	22T2 23N2	27 G4 38G4 G4'	34B3 43P6 47H6	50K 55V X4	59W2'	64M,R6 65D3 68C	945 K3'	38 & 4 Plagues	A/Earrings E Rings, Toggles, Spearheads & Ffnials	Calcite Vases Fragr Wood, Pitch, & Basketry. Bread cakes	LIV LV		
937		S Up		XX			26D1			59N1						Paste & Stone Amulets		
938		S W		XIX	12R					68N4'								
939	Children	S E		XIX	12R,T,T4,T5:		37J1	38P5		55S4"	64R4	94	4 Stea. 1 Plague	E Bangles do.	Paste Amulets Carn. Uzat'	L L L L		
940	Child	S Up		XIX			34E1							E Earrings				
941		S W		XX														
942	Child	S Up		XX					50J2									
943	No Tomb																	
944	Child	S E		XX					51G9					E Bangles				
945	do.	S E		XX				38G6'						E Earrings do.	Shells			
946				XIX			26D1									Paste Amulets & Shell	L	
947		S Up		XIX							74F5						XLIX	
948		N S		XIX				38G6'									L	
949	45 92 60	S E	175	XIX	6F 10P4	19P6		43H2',H3	50J4,U		68B5	91H3	35 Stea.	A Earring				
950	Child	N E	190	XX	12L4	22N5'	34B2", 2"		50J4					1 Stea.		Paste Amulets	L L L L	
951	11 30	S Up	187	XX						55S6'							XLIX	
952	14 39 Child	N Up	176	XIX	12J							75N5				Paste Amulets	L L L L	
953	19 56 do.	S Up	184	XIX			37J4							1 Stea.			L	
954	18 72	S Up	190	XIX			34B2"										L	
955	14 39 Child	S Up	178	XX	12V3				50U1	59N5			2 Stea.			Paste Amulets Paste Amulets	XLIX	
956	15 38 do.	S E	176	XX					50F					A Earrings				
957	27 58	N E	185	XX						59N			1 Stea.			Paste Amulets		
958	14 32 Child	S Up	184	XX						59T, W1'								
959	9 42 do.	S Up	185	XIX							68B5							
960	Plan Pl. LIX		80	XIX-XX	6H 12H K		26D1	35P6	43J6 P5	50G2 55W5' 59T1 J3 W6' 65D3'		85L3 91J5 K3	2 En AE. 9 24 7 3 1 2 9 2	Rings A Earring E Bowl R&E Earrings A Ring	Paste Amulets do	A LIV B LV C D F H J O22 XLIX L L L L		
961	16 39	S Up	185	XX							59T 68H5						Paste Amulets	
962	30 89 68	S E	175	XIX	6W 12L4			47H6			68B4			1 Plague				
963	14 55	S Up	185	XIX					50J1					1 Paste				
964	18 36 Child	S Up	170	XX					51G9									
965	21 72	S Up	185	XIX	12H		34B3											
966	16 64	S W	180	XIX			37H3					85H10						
967	12 48	S W	173	XIX								75N4						
968	12 39 Child	S E	168	XX		23L			50F2									

B E A D S																	
A	B-C	D	E-F	G-H	J	K	L	M	N	O-Q	R-T	U-V	W-X	Y-Z			
935	30C 63C 45C 68C	C35 L	28C 61C 117G 31W 69C 140W 45C 74B.G. 150C 54C 93A, 152C	F33G 40E	H16 L 39 Crv.	18C 72C 20C 85C 42G 97C	37Y 58Y 85G 40W 40C 88C 50G 62Y 92C 53C 70G 100C 55C Y 108C G 80KJ 110C		89C 124C 155P 109G 139C 157B 115C 148C 162P 117C P 170C 119G 155C	P 84RJ	R81G1P 83P 552P						
936	4B 57G 41H 63C 50Bd.		69C 105C 130G 83C 117C 132C	F33G	G10 Bo 20P 24G	36C 72P 38C 83P 54C 85C 97C	28 Bdl. 78C 79C	20P	13C 50G 139P 15P 18H 27G 113C 48YL 122C	P54P 56P	R83Bdl. 550P	U25C V10J 12J 14J				Y10G)P	
941				F33G													
942							62C										
946													V16 C				
947			6G 64G														
951							47 Gr.F 62 RJ 70C	72 RJ 87P									
952											546P 52P						
953																	
956																	
958	63A _g																
960B	25C 39C C 34C 66C	C25G1P	12Ca. 20Ca. 26Sc 80G 85C	F12F 40G	H23C 28C H18C	31C 70G 46C 88C 67C 93C 72G 97C	74G		109C 162P 37J 50G 152G 48C								
F	37G				H16G 28C	84G											
K	68C		20C 93G 114C	F33G		97C			162G		R86 Bdl.	V11C					Z14C
961	63C		134C						66C								
963			85G	F33G		62G			60G 90G 98G 62G								
964			152G			93C			74 YR								

TOMB	N E D CHAMBER	BODY H F	AZI MUTH	DATE	P O T T E R Y										SCARABS	METAL	VARIOUS	PLAT			
969	16 39 Ch1d	S Up	185	XX																	
970	18 55	S E	173	XIX																	
971	12 28 Ch1d	S	185	XX																	
972	21 57	S Up	185	XIX																	
973	14 45 10	S Up	180	XIX																	
974	22 44 29	S W	187	XIX																	
975	46 90 60	S E	143	XIX																	
976	13 37	S E	180	XIX																	
977	No Tomb																				
978	29 80 68	S Up	183	XIX																	
979	Ch1d	N E	177	XX																	
980	do	S Up	187	XIX																	
981			97	XIX																	
982			180	XX																	
983			95	XX																	
984			89	XIX																	
985			182	XX																	

B E A N D S													Y-Z	
A	B-C	D	E-F	G-H	J	K	L	M	N	O-Q	R-T	U-V	W-X	Y-Z
971														
978		B46BP												
979			130P											
980		B28P	105C											
982	B 34										R81P			
983			142C								85P			
984	30C 52B 25P 54C C 86C		12 Ca. 83C 85C 142C										V23C	
985														
EF 386	41H.		83C. 139C. 5N	F33G. F40C.										

662

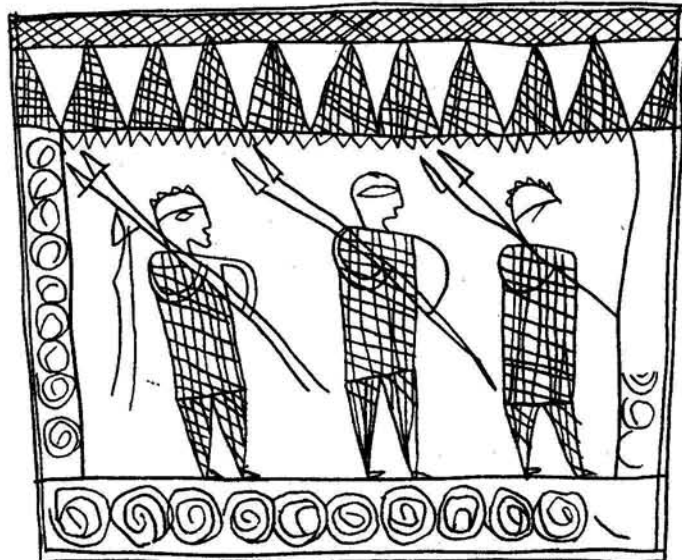

L.mst.

BETH PELET. REGISTER OF BEADS.

TOMB	TYPE	MATERIAL	DATE	TOMB	TYPE	MAT.	DATE	TOMB	TYPE	MAT.	DATE	TOMB	TYPE	MAT.	DATE	TOMB	TYPE	MAT.	DATE	TOMB	TYPE	MAT.	DATE	TOMB	TYPE	MAT.	DATE									
102	L 62	Carn.		126	N 45	Paste		201	F 40	Carn.		201	S 44	Glass		206	L 40	Carn.		213	H 26	Carn.		224	D 17	Carn. XXII		229	A 18	Glass XXII		240	L 62	Sard		
	102	"		(cont)	S 48	"		(cont)	G 50	Paste		(cont)	62	"		(cont)	60	Sard		(cont)	42	Sard.			20	"			66	Carn.		(cont)	66	Glass		
	N 50	"			U 66	Crys.			H 12	Carn.			T 34	Paste			N 29	Carn.			J 70	Paste			64	Clay			B 25	Paste			68	"		
104	A 21	"	XXI		W 41	Carn.			32	"			36	Glass			34	"			K 75	Carn.			74	Carn.			76	"			N 27	Paste		
	C 20	Glass			47	"			36	Sard			39	"			50	"			L 8	Glass			G 38	Paste			D 26	Carn.			29	Carn.		
	D 39	Carn.		127	L 62	"	XX		42	"			42	"			89	Crystal			M 50	"			L 29	"			J 28	Crystal			48	Carn.		
	74	"			117	"			49	Sard			55	"			122	Bronze			N 50	"			64	"			J 28	Crystal			89	Carn.		
	142	"			N 129	"			51	Carn.			62	Serpentine			129	Paste			H 20	Carn.			H 20	Carn.			J 28	Crystal			126	Paste		
	H 54	"			R 22	Shell			64	Sard			70	Bone			133	Glass			N 50	"			L 29	"			J 28	Crystal			135	Carn.		
	57	"			U 38	Hae.			J 20	Bone			70	Bone			135	Glass			N 50	"			90	"			J 28	Crystal			152	Paste		
	L 26	"		128	D 114	Sard			24	Glass			70	Bone			135	Carn.			N 50	"			90	"			J 28	Crystal			159	"		
	50	Sand			L 29	Carn.			33	"			72	Bone			168	Paste			N 50	"			93	"			J 28	Crystal			159	"		
	62	Carn.			40	"			42	Sard			72	"			P 34	"			N 50	"			95	"			J 28	Crystal			159	"		
	66	Sard			72	"			48	"			72	"			R 81	"			N 50	"			109	"			J 28	Crystal			159	"		
	N 50	Carn.			N 34	Paste				Carn.		202	D 12	Carn. XXII			R 81	"			N 50	"			135	"			J 28	Crystal			159	"		
	89	"			104	Carn.				Crystal			60	"			T 30	Glass			N 50	"			145	Paste			J 28	Crystal			159	"		
	98	Glass		130	H 26	"				54	Glass			H 32	"			J 54	Paste			N 50	"			152	Glass			J 28	Crystal			159	"	
	109	Carn.			J 12	"				62	Carn.			J 46	Limest.			K 40	Paste			N 50	"			152	Glass			J 28	Crystal			159	"	
	135	"			N 20	Glass				80	Paste			56	"			N 87	Glass			N 50	"			152	Glass			J 28	Crystal			159	"	
	150	"			R 81	Paste				80	Paste			72	Crystal			170	Paste			N 50	"			152	Glass			J 28	Crystal			159	"	
	R 26	Shell			86	Shell				Carn.			80	Paste			80	Hae.			N 50	"			152	Glass			J 28	Crystal			159	"		
	81	Paste			S 75	"				86	Glass			80	Paste			80	Hae.			N 50	"			152	Glass			J 28	Crystal			159	"	
	W 16	Carn.		131	A 34	Carn. XX				88	Limest.			L 40	Carn.			N 89	"			N 50	"			152	Glass			J 28	Crystal			159	"	
	X 35	Hae.			D 78	"				95	Carn.			64	Glass			N 89	"			N 50	"			152	Glass			J 28	Crystal			159	"	
	Y 8	Carn.			L 62	"				72	Carn.			72	Carn.			N 89	"			N 50	"			152	Glass			J 28	Crystal			159	"	
107	B 80	Paste	XX		N 159	Paste				17	Ivory			50	"			D 20	Carn.			N 50	"			152	Glass			J 28	Crystal			159	"	
	D 39	Carn.			132	D 105	"			21	Sard			85	"			C 64	Paste			N 50	"			152	Glass			J 28	Crystal			159	"	
	45	"			133	D 39	Carn. XXI			23	Glass			117	Paste			J 18	Carn.			N 50	"			152	Glass			J 28	Crystal			159	"	
	64	Paste			74	"				37	"			119	"			68	"			N 50	"			152	Glass			J 28	Crystal			159	"	
	137	Carn.			K 12	Glass				40	Carn.			148	"			93	"			N 50	"			152	Glass			J 28	Crystal			159	"	
	F 22	Calcite			L 90	Carn.				47	Glass			152	"			K 72	Paste			N 50	"			152	Glass			J 28	Crystal			159	"	
	G 12	Carn.			N 133	BkGs.				53	Carn.			152	"			L 90	Carn.			N 50	"			152	Glass			J 28	Crystal			159	"	
	L 42	"			162	Paste				Garnet				98	"			98	"			N 50	"			152	Glass			J 28	Crystal			159	"	
	58	"			R 81	Limest.				55	Sard			X 32	"			N 46	Glass			N 50	"			152	Glass			J 28	Crystal			159	"	
	100	Paste			U 90	Hae.				68	Carn.			104	"			75	Limest.			N 50	"			152	Glass			J 28	Crystal			159	"	
	N 50	Calcite		134	B 28	BkGs. XXI				84	Ivory			N 119	"			104	Carn.			N 50	"			152	Glass			J 28	Crystal			159	"	
	104	Carn.			D 17	Bl.				108	Carn.			135	"			104	Carn.			N 50	"			152	Glass			J 28	Crystal			159	"	
	109	"			114	Paste				114	Paste			137	"			135	"			N 50	"			152	Glass			J 28	Crystal			159	"	
	129	Paste			H 51	Sard				N 12	Glass			H 16	"			150	Carn.			N 50	"			152	Glass			J 28	Crystal			159	"	
	148	"			J 48	Crys.				15	Sard			L 42	"			162	Gold			N 50	"			152	Glass			J 28	Crystal			159	"	
	166	"			54	Glass				18	Limest.			58	"			U 35	Hae.			N 50	"			152	Glass			J 28	Crystal			159	"	
	168	"			58	Sard				20	Glass			72	"			V 10	Carn.			N 50	"			152	Glass			J 28	Crystal			159	"	
	R 22	Shell			L 90	Carn.				24	"			72	"			W 36	"			N 50	"			152	Glass			J 28	Crystal			159	"	
	81	Paste			N 48	"				29	Carn.			117	"			135	Carn.			N 50	"			152	Glass			J 28	Crystal			159	"	
	86	Shell			75	"				32	Bone			N 89	"			137	"			N 50	"			152	Glass			J 28	Crystal			159	"	
	U 21	Hae.			133	BkGs.				34	"			104	"			150	Paste			N 50	"			152	Glass			J 28	Crystal			159	"	
	W 32	Carn.			170	Paste				44	Paste			109	"			150	Paste			N 50	"			152	Glass			J 28	Crystal			159	"	
108	L 117	"			U 95	Hae.				48	"			135	Garnet			150	Paste			N 50	"			152	Glass			J 28	Crystal			159	"	
	N 111	Shell		135	B 46	Paste				50	Carn.			U 29	Carn.			H 57	Carn.			N 50	"			152	Glass			J 28	Crystal			159	"	
	109	N 143	Glass		D 78	Carn.				52	Sard			205	A 34	"	XX		J 54	Paste			N 50	"			152	Glass			J 28	Crystal			159	

BETH PELET. REGISTER OF BEADS.

TOMB	TYPE	MAT.	DATE	TOMB	TYPE	MAT.	DATE	TOMB	TYPE	MAT.	DATE	TOMB	TYPE	MAT.	DATE	TOMB	TYPE	MAT.	DATE	TOMB	TYPE	MAT.	DATE	TOMB	TYPE	MAT.	DATE	TOMB	TYPE	MAT.	DATE				
506 (cont)	L53	Crys.		527	D 45	Lmsl. XX		539 (cont)	N 29	Lmsl.		562	H 28	Carn.		629	L 94	Carn. XXI		659 (cont)	P 105	Silver		749	A 48	Onyx		808	D 93	Carn.		839	D 50	Paste XIX	
	55	Sard			L 53	Corn.			34	Glass			L 42	"			N 70	"			B 80	Paste			68	"			F 50	"			H 54	Sard	
	62	Corn.			90	"			50	Corn.			68	"			89	"			D 78	Corn.			C 55	Paste			H 39	Lmsl.			L 70	Corn.	
	68	"			N104	"			106	"			U 95	Hae.			U 95	Hae.			R 81	Paste			D 5	Onyx			L108	Corn.			N111	Shell	
	90	"			R 81	Paste			N 85	"			N 89	Corn.			R 28	Shell			D 26	"			P 41	Glass			T 26	Crystal					
	106	"			Y 12	Corn.			135	"			133	Glass			88	Corn.			64	"			P 41	Glass			L 100	Paste					
	N 29	"		528	A 25	" XX			137	"			54	"			705	P 39	Glass			88	Corn.			812	D 85	Corn.							
	34	"			D 76	"			172	"			J 15	Ameth.			715	G 26	Paste			112	"			114	"			R 28	Shell				
	48	"			Q 64	Paste			36	"			L 40	"			J 8	Lmsl.			132	Onyx			L108	Yel.Lmsl.			843	D 100	Paste				
	75	"			K 54	"			N 75	Corn.			72	Sard			80	Corn.			148	"			U 32	Corn.			845	D 145	Corn.				
	85	"			L106	Corn.			78	Gl.Quartz			N 75	Corn.			K 50	Paste			F 35	Corn.			J 58	"			846	G 8	Glass				
	104	"			N133	Glass			85	Corn.			R 81	Paste			N137	Corn.			J 58	"			L 58	Corn.			J 15	Quartz					
	131	Electrum			152	"			137	"			86	Shell			152	Glass			67	"			72	"			S 30	Diorite					
	139	Corn.			529	D 45	Lmsl.			P 84	"			Z 10	Lmsl.			159	"			70	"			98	"			35	Bone				
	150	"			L 53	Sard			540	G 55	Glass			N 40	Corn.			R 28	Shell			97	"			N135	"			847	D 145	Glass			
	R 28	Shell			N124	Shell			V 10	Corn.			D 60	Corn.			719	L 72	Glass			L 10	"			816	A 18	Glass							
	U 95	Hae.			L 66	Sard.			541	D 90	Clay			L 68	" XX			117	Corn.			50	Ameth.			K 20	Paste			N145	"				
509	G 50	Paste XX			L 66	Sard.			L 12	Corn.			N 52	"			N 89	"			62	Corn.			N 66	Corn.			853	D 148	Paste XX				
	H 54	Corn.			Corn.				N 29	"			85	"			W 32	Corn.			64	Ameth.			162	Paste			K 65	Gold					
	D 74	"			N135	"			52	Crys.			150	"			R 28	Shell			100	Ameth.			92	Corn.			U 42	Corn.					
	L 53	"			532	A 30	" XX			126	Glass			J 54	Glass			P106	Silver			102	Corn.			92	Corn.			U 42	Corn.				
	72	"			66	"			542	D130	Corn. XIX			56	Onyx			L 64	Glass			106	"			100	Ameth.			818	D 114	Lmsl. XIX			
	98	"			B 50	Gold			L 66	"			58	Corn.			H 28	"			F 35	Corn.			102	Corn.			L 53	Corn.					
	N 52	"			86	"			N 85	"			L 87	"			L 37	Glass			H 64	Sard			98	"			98	"					
	119	"			D114	Corn.			133	Glass			N 75	"			42	Corn.			L 53	Corn.			Ameth.				N 50	"					
	162	Paste			130	"			R 28	Shell			78	Gl.Quartz			53	"			M 10	Corn.			M 10	Corn.			819	N104	"				
	R 28	Shell			148	"			89	Paste			89	Paste			N 46	Glass			N 62	"			N 62	"			821	A 66	"				
	83	Lmsl.			F 40	"			117	Corn.			119	"			62	Corn.			133	"			D 45	"			D 45	"					
	W 16	Corn.			J 42	"			543	L 37	Glass			T 10	"			64	Corn.			P 90	Silver			134	Paste			134	Paste				
510	D 69	" XXI			88	"			546	H 54	Corn.			N 62	"			N 62	"			P 95	Silver			92	"			L108	Corn.				
	L 53	"			K 78	Paste			L 58	"			N 15	Corn.			75	"			726	K 8	Glass			98	"			N 145	Paste				
	R 81	Paste			82	Gold			74	Corn.			126	Paste			89	"			729	L106	Corn.			R 83	Corn.			R 28	Shell				
	83	"			L 37	Glass			N 8	Glass			50	Corn.			50	Corn.			N 50	"			X 39	Agate			Y 3	Bone					
511	D 69	Corn. XXI			53	Sard			52	Crys.			L 53	Corn.			H 44	"			166	Paste			52	Ameth.			823	H 54	Corn.				
	L 72	"			N 32	Corn.			85	Corn.			N 78	Gl.Quartz			J 80	Sard			P 95	Silver			62	Glass			L 90	"					
	90	"			50	"			89	Paste			89	Paste			L 40	Corn.			732	F 22	Glass			72	Onyx			N 89	"				
	N104	"			89	"			104	Corn.			104	Corn.			N 40	"			J 80	Corn.			74	Corn.			135	Garnet					
	135	Sard			139	"			145	Paste			119	"			L 64	Glass			L 64	Glass			72	Corn.			R 28	Shell					
	R 83	Paste			152	Paste			552	A34	Corn. XIX			129	Paste			98	"			98	"			72	Corn.			825	D 40	Electrum			
512	D 62	Corn.			R 26	Shell			D 20	Silver			135	Glass			135	Glass			Q 8	"			734	D 78	" XVI			68	Gold				
	J 15	Lmsl.			W 44	Corn.			42	"			104	Corn.			129	Paste			737	N117	Corn.			N 48	Corn.			D 114	Corn.				
	L 26	Corn.			533	D114	" XIX			114	Silver			135	Glass			135	Glass			P 26	Glass			750	L 68	"			R 28	Shell			
	N 29	Lmsl.			H 16	Glass			148	"			55	Corn.			105	Corn.			98	"			753	A 55	Agate			N 89	"				
	89	Corn.			L 90	Corn.			155	"			129	Paste			42	Clay			729	L106	Corn.			L 42	Corn.			68	Gold				
514	A 30	" XX			N 89	"			F 10	"			135	Glass			78	"			N 50	"			53	Crys.			D 114	Corn.					
	41	Glass			R 28	Shell			Diorite				104	Corn.			105	Corn.			734	D 78	" XVI			53	Crys.			R 28	Shell				
	D 20	Corn.			81	Paste			J 62	Corn.			129	Paste			42	Clay			741	L 40	Corn.			N 48	Corn.			Y 3	Bone				
	114	"			534	A 50	Lmsl. XXII			80	"			135	Glass			78	"			741	L 40	Corn.			52	Ameth.			823	H 54	Corn.		
	H 32	"			B 10	Paste			80	"			104	Corn.			105	Corn.			Q 8	"			742	D 83	"			L 90	"				
	L 26	"			D 45	Quartz			80	"			129	Paste			105	Corn.			166	Paste			108	"			72	"					
	29	"			Q 64	Paste			97	"			135	Glass			105	Corn.			P 95	Silver			108	"			N 89	"					
	42	"			H 28	Corn.			97	"			145	Paste			105	Corn.			732	F 22	Glass			N 20	Glass			825	D 40	Electrum			
	62	"			42	"			97	"			145	Paste			105	Corn.			732	F 22	Glass			75	Corn.			825	D 40	Electrum			
	90	"			64	Lmsl.			94	"			145	Paste			105	Corn.			732	F 22	Glass			75	Corn.			825	D 40	Electrum			
	N104	"			J 28	Corn.			94	"			145	Paste			105	Corn.			732	F 22	Glass			75	Corn.			825	D 40	Electrum			
	109	"			67	"			94	"			145	Paste			105	Corn.			732	F 22	Glass			75	Corn.			825	D 40	Electrum			
	R 28	Shell			80	"			94	"			145	Paste			105	Corn.			732	F 22	Glass			75	Corn.			825	D 40	Electrum			
	J 80	Corn.			K 40	Paste			94	"			145	Paste			105	Corn.			732	F 22	Glass			75	Corn.			825	D 40	Electrum			
	L 55	"			L 40	Yel.Lmsl.			94	"			145	Paste			105	Corn.			732	F 22	Glass			75	Corn.			825	D 40	Electrum			
516	N 87	Glass XX			53	"			94	"			145	Paste			105	Corn.			732	F 22	Glass			75	Corn.			825	D 40	Electrum			
	R 28	Shell			Corn.				94	"			145	Paste			105	Corn.			732	F 22	Glass			75	Corn.			825	D 40	Electrum			
	N133	Glass	</																																

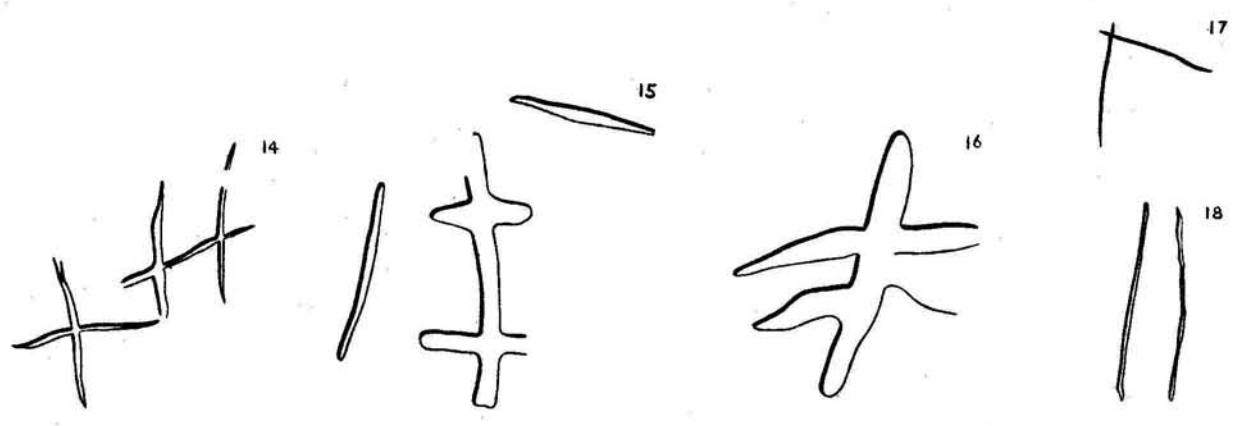
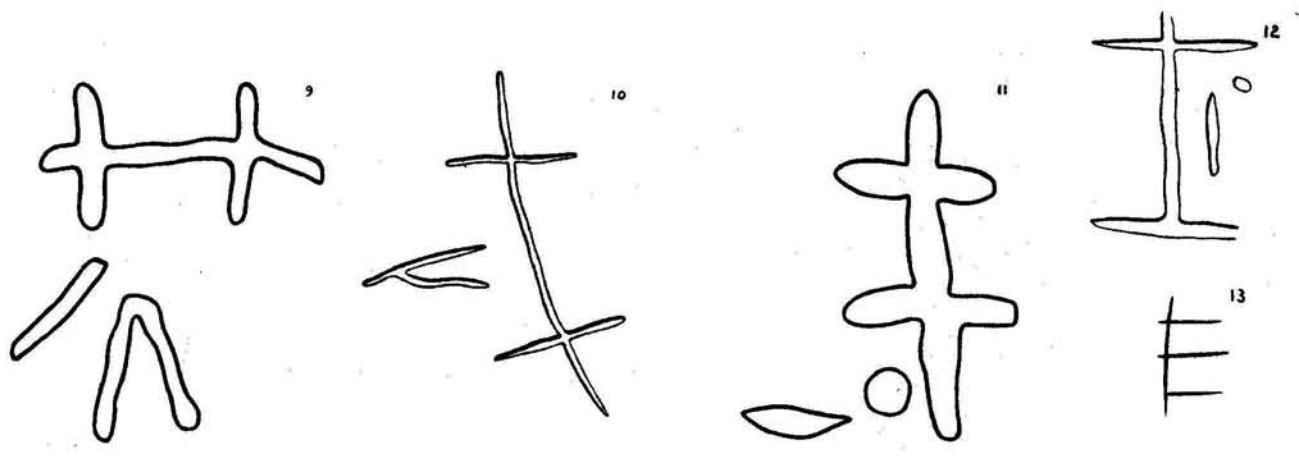
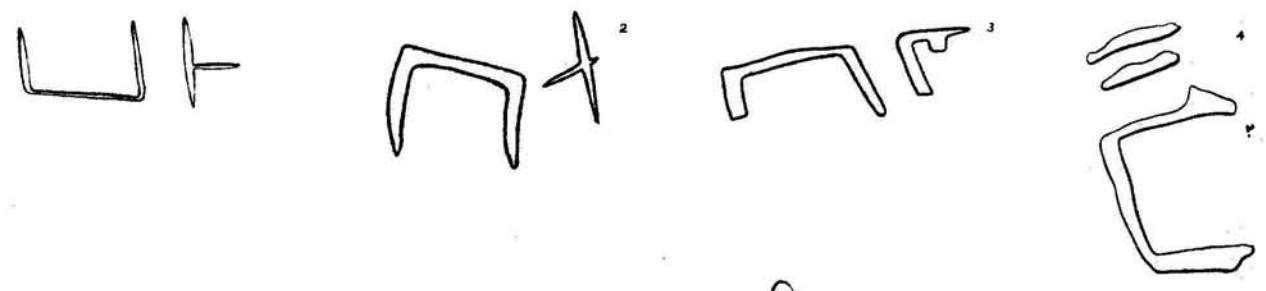

PUBLICATIONS

OF THE EGYPTIAN RESEARCH ACCOUNT AND BRITISH SCHOOL OF ARCHAEOLOGY IN EGYPT

- I. BALLAS, 1895; by J. E. QUIBELL. (Out of print; obtainable in joint volume NAQADA AND BALLAS, by FLINDERS PETRIE. 68 plates. 20s.)
- II. THE RAMESSEUM, 1896; by J. E. QUIBELL. (Out of print.)
- III. EL KAB, 1897; by J. E. QUIBELL.
- IV. HIERAKONPOLIS I, 1898; text by W. M. F. P. 43 plates. 20s.
- V. HIERAKONPOLIS II, 1899; by F. W. GREEN and J. E. QUIBELL. 39 plates (4 coloured and 20 photographic).
- VI. EL ARABAH, 1900; by J. GARSTANG. 40 plates. (Out of print.)
- VII. MAHASNA, 1901; by J. GARSTANG and KURT SETHE. 43 plates. (Out of print.)
- VIII. TEMPLE OF THE KINGS, 1902; by A. ST. GEORGE CAULFEILD. 24 plates. (Out of print.)
- IX. THE OSIREION, 1903; by M. A. MURRAY. 37 plates. 25s.
- X. SAQQARA MASTABAS I, 1904; by M. A. MURRAY; and GUROB, by L. LOAT. 64 plates. 30s.
- XII. HYKSOS AND ISRAELITE CITIES, 1906; by FLINDERS PETRIE and J. GARROW DUNCAN. 40 plates. 25s.
In double volume with 94 plates. 45s. (This latter is out of print.)
- XIII. GIZEH AND RIFEH, 1907; by FLINDERS PETRIE. 40 plates. 25s. In double volume with 109 plates. 50s.
- XIV. ATHRIBIS, 1908; by FLINDERS PETRIE, J. H. WALKER and E. B. KNOBEL. 43 plates. (Out of print.)
- XV. MEMPHIS I, 1908; by FLINDERS PETRIE and J. H. WALKER. 54 plates. 25s.
- XVI. QURNEH, 1909; by FLINDERS PETRIE and J. H. WALKER. 56 plates. (Out of print.)
- XVII. THE PALACE OF APRIES (MEMPHIS II), 1909; by FLINDERS PETRIE and J. H. WALKER. 35 plates. 25s.
- XVIII. MEYDUM AND MEMPHIS III, 1910; by FLINDERS PETRIE, E. MACKAY and G. WAINWRIGHT. 47 plates. 25s.
- XIX. HISTORICAL STUDIES, 1910; 25 plates. 25s. (Studies, vol. ii.)
- XX. ROMAN PORTRAITS (MEMPHIS IV), 1911; by FLINDERS PETRIE. 32 plates. 25s.
- XXI. THE LABYRINTH AND GERZEH, 1911; by FLINDERS PETRIE, E. MACKAY and G. WAINWRIGHT. 52 plates. 25s.
- XXII. PORTFOLIO OF HAWARA PORTRAITS. 24 coloured plates. 50s.
- XXIII. TARKHAN I AND MEMPHIS V, 1912; by FLINDERS PETRIE. 81 plates. 25s.
- XXIV. HELIOPOLIS I AND KAFR AMMAR, 1912; by FLINDERS PETRIE. 58 plates. 25s.
- XXV. RIQEQH AND MEMPHIS VI, 1913; by R. ENGELBACH, HILDA PETRIE, M. A. MURRAY and FLINDERS PETRIE. 62 plates. 25s.
- XXVI. TARKHAN II, 1913; by FLINDERS PETRIE. 72 plates. 25s.
- XXVII. LAHUN I, THE TREASURE, 1914; by GUY BRUNTON. 23 plates (8 coloured). 63s. Subscription price, 42s.
- XXVIII. HARAGEH; by R. ENGELBACH and B. GUNN. 81 plates. 25s.
- XXIX. SCARABS AND CYLINDERS, 1915; by FLINDERS PETRIE. 73 plates. 32s.
- XXX. TOOLS AND WEAPONS, 1916; by FLINDERS PETRIE. 76 plates. 35s.
- XXXI. PREHISTORIC EGYPT, 1917; by FLINDERS PETRIE. 53 plates. 25s.
- XXXII. CORPUS OF PREHISTORIC POTTERY; by FLINDERS PETRIE. 58 plates. 25s.
- XXXIII. LAHUN II, THE PYRAMID, 1920; by FLINDERS PETRIE, G. BRUNTON and M. A. MURRAY. 75 plates. 25s.
- XXXIV. SEDMENT I, 1921; by FLINDERS PETRIE and G. BRUNTON. 47 plates. 25s.
- XXXV. SEDMENT II, 1921; by FLINDERS PETRIE and G. BRUNTON. 43 plates. 25s.
- XXXVI. THE GOSPEL OF ST. JOHN, COPTIC MS.; by Sir HERBERT THOMPSON. 80 plates. 25s.
- XXXVII. TOMBS OF THE COURTIERI AND OXYRHYNKHOS; by FLINDERS PETRIE, ALAN GARDINER, HILDA PETRIE and M. A. MURRAY. 55 plates. 25s.
- XXXVIII. BUTTONS AND DESIGN SCARABS; by FLINDERS PETRIE. 30 plates. 25s.
- XXXIX. ANCIENT WEIGHTS AND MEASURES; by FLINDERS PETRIE. 54 plates. (Out of print.)
- XL. GLASS STAMPS AND WEIGHTS; by FLINDERS PETRIE. 26 plates. Univ. Coll. (Out of print.)
- XLI. GUROB; by GUY BRUNTON and R. ENGELBACH. 53 plates. 25s.
- XLII. OBJECTS OF DAILY USE; by FLINDERS PETRIE. 62 plates. 50s.
- XLIII. GERAR; by FLINDERS PETRIE. 72 plates. 50s.
- XLIV-V. QAU AND BADARI I and II; by GUY BRUNTON. 49 and 55 plates. 25s. each.
- XLVI. BADARIAN CIVILISATION; by GUY BRUNTON and G. CATON-THOMPSON. 85 plates. 50s.
- XLVII. BAHREIN AND HEMAMIEH; by E. MACKAY, L. HARDING, and FLINDERS PETRIE. 29 plates. 25s.
- XLVIII. BETH-PELET I; by FLINDERS PETRIE and O. TUFNELL. 71 plates. 50s.
- XLIX. CORPUS OF PALESTINIAN POTTERY. J. GARROW DUNCAN. 84 plates. 30s.
- L. QAU AND BADARI III; by GUY BRUNTON. 57 plates. 50s.
- LI. ANTAEOPOLIS (QAU); by FLINDERS PETRIE. 28 plates. 25s.
- LII. BETH-PELET II; by EANN MACDONALD, J. L. STARKEY and L. HARDING. 92 plates. 50s.
- LIII. ANCIENT GAZA I; by FLINDERS PETRIE. 62 plates. 50s.

Subscriptions of One Guinea for the Annual Single Volumes, or Two Guineas for the Two Annual Volumes, are received by the Hon. Secretary, at the Edwards Library, University College, Gower Street, London, W.C.1, where also copies of the above works can be obtained.