

EX LIBRIS

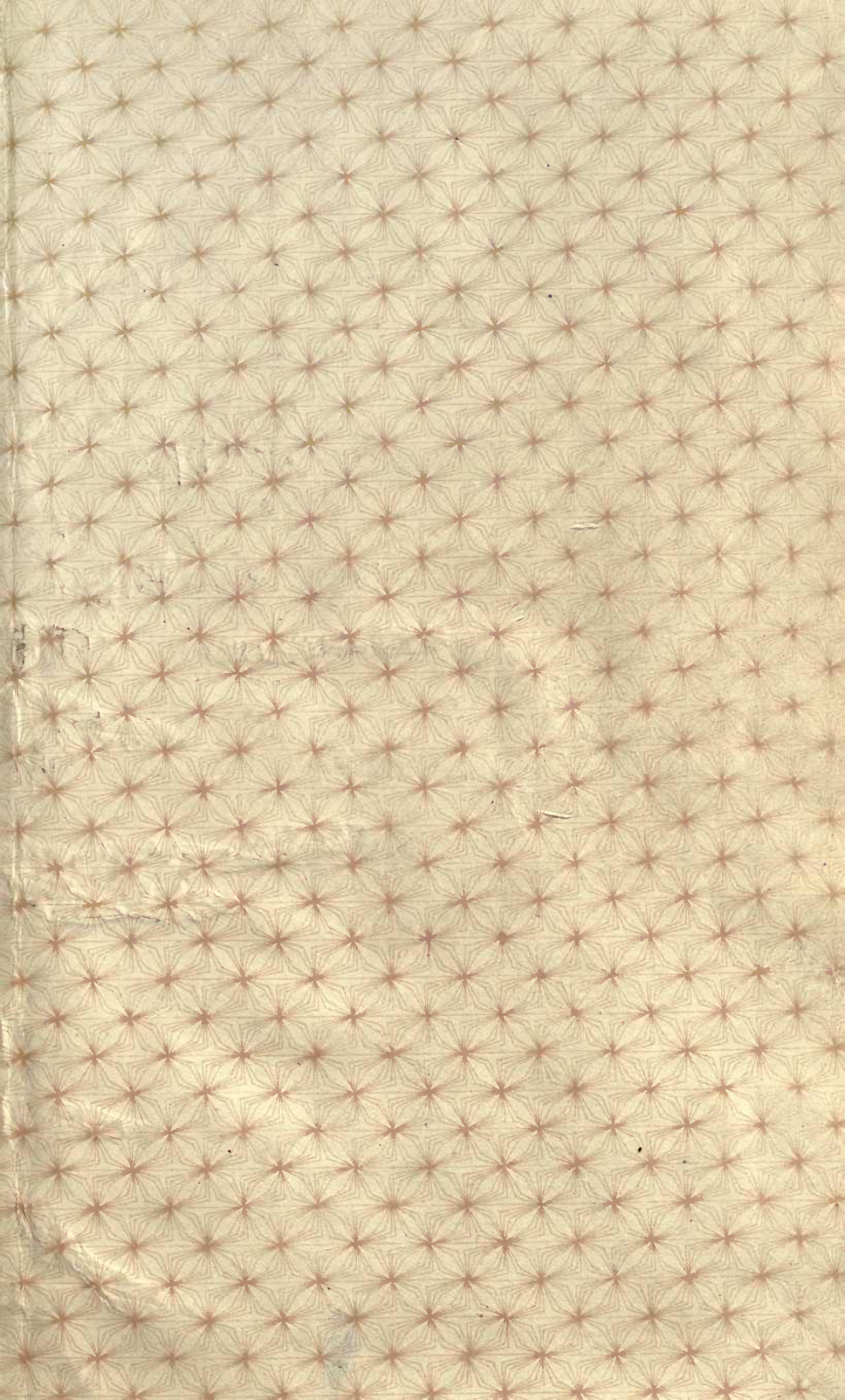

PRINCIPLES AND PRACTICE
OF
ELECTRICAL ENGINEERING

BY

ALEXANDER GRAY

WHT. SCH., B. SC. (EDIN. AND MCGILL)

ASSISTANT PROFESSOR OF ELECTRICAL ENGINEERING,
MCGILL UNIVERSITY, MONTREAL, CANADA;
AUTHOR OF ELECTRICAL MACHINE DESIGN

FIRST EDITION



McGRAW-HILL BOOK COMPANY, INC.
239 WEST 39TH STREET, NEW YORK
6 BOUVERIE STREET, LONDON, E. C.

1914

TK 145
G7

COPYRIGHT, 1914, BY THE
MCGRAW-HILL BOOK COMPANY, INC.

TO THE
LIBRARY OF

THE MAPLE PRESS YORK PA

PREFACE

The following work is based on a lecture and laboratory course given to the senior civil, mechanical, and mining students at McGill University. It is therefore suited for men who desire to obtain a broad idea of the principles and practice of electrical engineering and who have only a limited amount of time to spend on the subject. For such men it is necessary to emphasize the fundamental principles, and to develop the subject by elaborating on these principles rather than by the solution of mathematical equations, because only in this way can the student be given such a grip of the subject in the short time available, that he is able thereafter to make intelligent use of the data contained in the electrical handbooks, or take up with advantage a further study of the special treatises on the subject.

The book gives a self-contained lecture and laboratory course. The chapters on the control and applications of electrical machinery have been so written that large sections of these chapters may be set for private reading. In the laboratory course, complete references are given to the theory and purpose of each experiment, and these references in no case go beyond the text contained in the body of the work.

The author wishes to acknowledge his indebtedness to Mr. A. M. S. Boyd and to Mr. R. Kraus for their help and criticism.

A. G.

MCGILL UNIVERSITY,
Sept. 1, 1914.

CONTENTS

PREFACE	v
INTRODUCTION	xxi

CHAPTER I

MAGNETISM AND MAGNETIC UNITS

Article	Page
1. Magnets	1
2. Coulomb's Law	1
3. The Magnetic Field	1
4. Lines of Force.	2
5. Lines of Force from a Unit Pole	3

CHAPTER II

ELECTROMAGNETISM

6. Direction of an Electric Current	4
7. Magnetic Field Surrounding a Conductor Carrying Current.	4
8. Force at the Center of a Circular Loop Carrying Current	4
9. Electromagnets	5
10. Force on a Conductor Carrying Current in a Magnetic Field	6
11. Moving Coil Ammeters.	8

CHAPTER III

ELECTROMAGNETIC INDUCTION

12. Electromagnetic Induction	9
13. The Direction of the Induced Electromotive Force.	9
14. Mutual Induction	11
15. Self Induction.	11

CHAPTER IV

WORK AND POWER

16. Transformation of Mechanical into Electrical Energy	13
17. Unit of Work	14
18. Heat Energy and Electrical Energy	15
19. Conversion Factors.	15
20. Problems on Work and Power.	15

CHAPTER V

ELECTRIC CIRCUITS AND RESISTANCE

Article	Page
21. The Flow of Electricity	18
22. Ammeters and Voltmeters.	19
23. Resistance Circuits.	19
24. Ohm's Law	20
25. Specific Resistance.	20
26. Variation of Resistance with Temperature.	21
27. Power Expended in a Resistance	21
28. Insulating Materials	22
29. Dielectric Strength of Insulating Material	22
30. Series and Parallel Circuits	22
31. Voltage Drop in a Transmission Line.	23

CHAPTER VI

RHEOSTATS AND RESISTORS

32. Rheostats	25
33. Resistors	26
34. Heater Units	27
35. Cast-iron Grid Resistance	27
36. Carbon Pile Rheostat	29
37. Liquid Rheostat	29
38. Size of a Rheostat	31

CHAPTER VII

MAGNETIC CIRCUITS AND MAGNETIC PROPERTIES OF IRON

39. Magnetic Field due to a Solenoid.	32
40. Permeability	33
41. Reluctance of a Magnetic Circuit	33
42. Magnetization Curves	34
43. Residual Magnetism	35
44. Molecular Theory of Magnetism.	36
45. Hysteresis	36

CHAPTER VIII

SOLENOIDS AND ELECTROMAGNETS

46. Pull of Solenoids	37
47. Electric Hammer	38
48. Variation of the Pull of a Solenoid	38
49. Circuit Breaker	39
50. Laws of Magnetic Pull	40
51. Solenoids with Long and Short Plungers	41
52. Iron-clad Solenoids	41

Article	Page
53. Lifting and Holding Magnets	43
54. Saturation of a Magnetic Circuit	46
55. Electromagnetic Brakes and Clutches	46
56. Magnetic Separator	47

CHAPTER IX

ARMATURE WINDINGS FOR DIRECT-CURRENT MACHINERY

57. Principle of Operation of the Electric Generator	48
58. Gramme Ring Winding	48
59. Commutator and Brushes	50
60. Multipolar Windings	51
61. Drum Windings	52
62. Lamination of the Armature Core	55

CHAPTER X

CONSTRUCTION AND EXCITATION OF DIRECT-CURRENT MACHINES

63. Multipolar Construction	56
64. Armature Construction	58
65. Commutator	58
66. The Brushes	58
67. Poles and Yoke	58
68. Large Generators	58
69. Excitation	59

CHAPTER XI

THEORY OF COMMUTATION

70. Commutation	62
71. Theory of Commutation	63
72. Shifting of the Brushes	63
73. Interpole Machines	65
74. Carbon Brushes	66

CHAPTER XII

ARMATURE REACTION

75. The Cross-magnetizing Effect	67
76. The Demagnetizing Effect	68
77. Effect of Armature Reaction on Commutation	68

CHAPTER XIII

CHARACTERISTICS OF DIRECT-CURRENT GENERATORS

78. Magnetization or No-load Saturation Curve	70
79. Self Excitation	71

Article	Page
80. Regulation Curve of a Separately Excited or of a Magneto Generator	71
81. Regulation Curve of a Shunt Generator	72
82. To Maintain the Terminal Voltage Constant	74
83. Compound Generators	74
84. The Regulation Curve of a Series Generator	75
85. Problem on Generator Characteristics	76

CHAPTER XIV

THEORY OF OPERATION OF DIRECT-CURRENT MOTORS

86. Driving Force of a Motor	78
87. Driving and Retarding Forces in Generators and Motors	78
88. The Back E.M.F.	79
89. Theory of Motor Operation	80
90. Speed and Torque Formulæ	82
91. Improvement of Commutation by Shifting of the Brushes.	83
92. Armature Reaction in Generators and Motors	83

CHAPTER XV

CHARACTERISTICS OF DIRECT-CURRENT MOTORS

93. The Starting Torque	85
94. The Starting Resistance	85
95. Motor Starter	87
96. No-voltage Release	87
97. Load Characteristics	88
98. Effect of Armature Reaction on the Speed	89
99. Variable Speed Operation	89
100. The Starting Torque	90
101. The Starting Resistance	91
102. Load Characteristics	92
103. Speed Adjustment	92
104. The Compound Motor	93

CHAPTER XVI

LOSSES, EFFICIENCY AND HEATING

105. Mechanical Losses in Electrical Machinery	95
106. Copper Losses	95
107. Hysteresis Loss	95
108. Eddy Current Loss	96
109. Stray Loss	96
110. The Efficiency of a Machine	97
111. Heating of Electrical Machinery	99
112. Permissible Temperature Rise	99

CHAPTER XVII

MOTOR APPLICATIONS

Article	Page
113. Limits of Output	100
114. Open, Semi-enclosed and Totally Enclosed Motors	100
115. Intermittent Ratings.	101
116. Effect of Speed on the Cost of a Motor.	101
117. Choice of Type of Motor	101
118. Line Shaft Drive	102
119. Wood-working Machinery	102
120. Reciprocating Pumps	103
121. Traction Motors	103
122. Crane Motors	103
123. Express Passenger Elevators	103
124. Shears and Punch Presses	103

CHAPTER XVIII

ADJUSTABLE SPEED OPERATION OF DIRECT-CURRENT MOTORS

125. Speed Variation of Shunt Motors by Armature Control	105
126. Speed Variation of Shunt Motors by Field Control	107
127. Speed Regulation of an Adjustable Speed Shunt Motor.	107
128. Electric Drive for Lathes and Boring Mills	108
129. Multiple Voltage Systems	109
130. Ward Leonard System	110
131. Drive for Ventilating Fans	111
132. Armature Resistance for Speed Reduction	112
133. Motors for Small Desk Fans	112
134. Printing Presses	113

CHAPTER XIX

HAND-OPERATED FACE PLATE STARTERS AND CONTROLLERS

135. Knife Switches	114
136. Auxiliary Carbon Contacts	114
137. Blow-out Coils	115
138. Horn Gaps	116
139. Fuses	117
140. Circuit Breakers.	117
141. Motor Starters	117
142. The Sliding Contact Type of Starter	117
143. Starting Resistance	118
144. Overload Release	118
145. Multiple Switch Starters.	119
146. Compound Starters	120
147. Speed Regulators	121
148. Controllers for Series Motors	122

CHAPTER XX

DRUM TYPE CONTROLLERS

Article	Page
149. Drum Type Controllers	124
150. No-voltage and Overload Release	125
151. Street Car Controller for Series Parallel Control	126
152. Reversing Drum	129
153. Mechanical Features of Drum Controllers	129

CHAPTER XXI

AUTOMATIC STARTERS AND CONTROLLERS

154. Automatic Solenoid Starter	130
155. Float Switch Control.	130
156. Magnetic Switch Controller.	131
157. Multiple Unit Control of Railway Motors	133
158. Automatic Magnetic Switch Starters.	133
159. Automatic Starter with Series Switches	135

CHAPTER XXII

ELECTROLYSIS AND BATTERIES

160. Electrolysis	139
161. Voltmeter	139
162. Electric Battery	140
163. Theory of Battery Operation	140
164. Polarization.	141
165. The E.M.F. and Resistance of Cells	141
166. The Daniell Cell	141
167. Calculation of the E.M.F. of a Daniell Cell	142
168. Local Action	143
169. Leclanché Cell.	143
170. Dry Cells.	143
171. Edison Lalande Cell	144
172. Power and Energy of a Battery	144
173. Battery Connections	144

CHAPTER XXIII

STORAGE BATTERIES

174. Action of the Lead Cell.	146
175. Storage or Secondary Battery	147
176. Sulphation	147
177. Construction of the Plates	148
178. Construction of a Lead Battery	149
179. Voltage of a Lead Battery	151
180. Capacity of a Cell	153

Article	Page
181. Ampere-hour Efficiency	153
182. Watt-hour Efficiency	154
183. Effect of Temperature on the Capacity	155
184. Limit of Discharge	155
185. Treatment of Lead Cells	156
186. Action of the Edison Battery	157
187. Construction of the Plates	158
188. Construction of an Edison Battery	158
189. The Voltage of an Edison Battery	160
190. Characteristics of an Edison Battery	160

CHAPTER XXIV

OPERATION OF GENERATORS

191. Operation of the Same Shunt Machine as a Generator or as a Motor	162
192. Loading Back Tests	163
193. Parallel Operation	164
194. Shunt Generators in Parallel	164
195. Division of Load among Shunt Generators in Parallel	165
196. Compound Generators in Parallel	166
197. Division of Load among Compound Generators	167

CHAPTER XXV

OPERATION OF GENERATORS AND BATTERIES IN PARALLEL

198. Isolated Lighting Plants	169
199. Lighting Plants for Farm Houses	169
200. Lamp Circuit Regulator	170
201. Small Isolated Power Stations	171
202. Resistance Control	171
203. End Cell Control	172
204. Booster Charge, End Cell Discharge	173
205. Capacity of Battery	175
206. Batteries for Rapidly Fluctuating Loads	176
207. The Differential Booster	176
208. Carbon Pile Regulator	176
209. Floating Batteries	179

CHAPTER XXVI

CAR LIGHTING AND VARIABLE SPEED GENERATORS

210. Systems of Vehicle Lighting	181
211. Straight Storage for Trains	181
212. Head and End System	181
213. Carbon Pile Lamp Regulator	182
214. The Axle Generator Systems	182
215. Automatic Switch	183

Article	Page
216. Generator Regulator	183
217. Pole Changer	184
218. The Stone Generator.	185
219. Lighting Generators for Motor Cars	186
220. Constant Speed Generators	186
221. Bucking Field Coils	186
222. Vibrating Contact Regulator	187
223. The Rosenberg Generator.	188

CHAPTER XXVII

ALTERNATING VOLTAGES AND CURRENTS

224. The Simple Alternator	191
225. The Wave Form.	193
226. The Oscillograph	193
227. Frequency	194
228. Vibrating Reed Type of Frequency Meter	195
229. Average Value of Current and Voltage	197
230. The Heating Effect of an Alternating Current.	197
231. Symbols	198
232. Voltmeters and Ammeters for Alternating-current Circuits	198

CHAPTER XXVIII

REPRESENTATION OF ALTERNATING CURRENTS AND VOLTAGES

233.	200
234. Electrical Degrees	200
235. Vector Representation of Alternating Voltages and Currents	201
236. The Sum of Two Alternating Voltages of the Same Frequency.	203

CHAPTER XXIX

INDUCTIVE CIRCUITS

237. Inductance	205
238. Make and Break Spark Ignition.	206
239. The Coefficient of Self Induction.	206
240. Alternating Currents in Inductive Circuits	207
241. Voltage and Current Relations	208
242. Power in an Inductive Circuit.	209
243. Examples of Inductive and Non-inductive Circuits.	209
244. Voltage, Current and Power in Resistance Circuits.	211
245. Resistance and Inductance in Series	212
246. The Power Factor	213
247. The Wattmeter	214
248. Transmission Line Regulation and Losses	215
249. Resistance and Inductance in Parallel	216

CHAPTER XXX

CAPACITY CIRCUITS

Article	Page
250. Condensers	218
251. Capacity Circuits with Direct and with Alternating Currents . .	219
252. Phase Relation between Voltage and Current in Capacity Circuits .	220
253. Voltage and Current Relations in Capacity Circuits	221
254. Parallel Plate Condenser	222
255. Power in Capacity Circuits	223
256. The Formulæ Used in Circuit Problems	223
257. Resistance, Inductance and Capacity in Series.	224
258. Resistance, Inductance and Capacity in Parallel.	226

CHAPTER XXXI

ALTERNATORS

259. Alternator Construction	229
260. Two-phase Alternator	230
261. Three-phase Alternators	231
262. Y-Connection	233
263. Delta-connection	233
264. Voltages, Currents and Power in a Y-Connected Machine . . .	235
265. Voltages, Currents and Power in a Delta-connected Machine . .	236
266. Connection of a Three-phase Load	237
267. Power Measurement in Polyphase Circuits	238
268. Alternator Construction	239
269. The Revolving Armature Type of Alternator	240
270. The Inductor Alternator	241
271. Magneto Alternators	242

CHAPTER XXXII

ALTERNATOR CHARACTERISTICS

272. Armature Reaction	244
273. Vector Diagram at Full-load	245
274. Regulation Curves of an Alternator	245
275. Experimental Determination of Alternator Reactance	246
276. Automatic Regulators	249
277. Efficiency	250
278. Rating of Alternators	251

CHAPTER XXXIII

SYNCHRONOUS MOTORS AND PARALLEL OPERATION

279. Principle of Operation of Synchronous Motors	252
280. The Back E.M.F. of a Synchronous Motor	253
281. Mechanical Analogy	254

Article	Page
282. Vector Diagram for a Synchronous Motor	254
283. Maximum Output	255
284. Operation of a Synchronous Motor when Under- and Over-excited	256
285. Use of the Synchronous Motor for Power Factor Correction . .	256
286. Synchronizing	258
287. Hunting	258
288. Parallel Operation of Alternators	259

CHAPTER XXXIV

TRANSFORMER CHARACTERISTICS

289. The Transformer	261
290. Constant Potential Transformer	261
291. Vector Diagram for a Transformer.	263
292. Induction Furnace.	263
293. Leakage Reactance	264
294. Leakage Reactance in Standard Transformers and in Induction Furnaces	266
295. The Constant-current Transformer	267
296. The Efficiency of a Transformer.	268
297. Hysteresis Loss	269
298. Eddy Current Loss	269
299. Iron Losses	269
300. The All-day Efficiency	269
301. Cooling of Transformers	270

CHAPTER XXXV

TRANSFORMER CONNECTIONS

302. Lighting Transformers	273
303. Connections to a Two-phase Line	273
304. Connections to a Three-phase Line.	276
305. Advantages and Disadvantages of the Y- and Delta-connection.	278
306. Types of Transformer	279
307. The Autotransformer.	279
308. Boosting Transformers and Feeder Regulators.	281

CHAPTER XXXVI

POLYPHASE INDUCTION MOTORS

309. The Induction Motor.	283
310. The Revolving Field	284
311. The Revolving Field of a Three-phase Motor	285
312. Multipolar Machines.	287
313. The Starting Torque.	287
314. The Wound Rotor Motor.	288

Article	Page
315. Running Conditions	290
316. Vector Diagrams for the Induction Motor	291
317. Adjustable Speed Operation	293
318. Induction Generator	294
319. Self-starting Synchronous Motors	294
320. Dampers for Synchronous Machines	295

CHAPTER XXXVII

INDUCTION MOTOR APPLICATIONS AND CONTROL

321. Choice of Type of Motor	296
322. Line Shaft Drive	297
323. Wood-working Machinery	297
324. Cement Mills	297
325. Motors for Textile Machinery	298
326. Adjustable Speed Motors	298
327. Crane Motors	298
328. Shears and Punch Presses	299
329. Adjustable Speed Service	299
330. Resistance for Adjustable Speed Motors	300
331. Switches for Alternating-current Circuits	300
332. Starting of Squirrel-cage Induction Motors	301
333. Starting Compensator	302
334. The Star-delta Method of Starting	304
335. Starter for a Wound Rotor Motor	305
336. Automatic Starters	306

CHAPTER XXXVIII

SINGLE-PHASE MOTORS

337. Single-phase Induction Motors	308
338. Split-phase Method of Starting	308
339. Running Torque of a Single-phase Motor	308
340. Single-phase Series Motor	310
341. Armature Reaction	312
342. The Repulsion Motor	313
343. Commutation of Series and Repulsion Motors	314
344. Wagner Single-phase Motor	314

CHAPTER XXXIX

MOTOR-GENERATOR SETS AND ROTARY CONVERTERS

345. Motor-generator Set	315
346. The Booster Set	315
347. The Balancer Set	316
348. Three-wire Generator	317
349. To Transform from Alternating to Direct Current	318

Article	Page
350. Rotary Converter	318
351. Motor-generator Sets and Rotary Converters	319
352. Polyphase Rotary Converter	320
353. Split-pole Rotary Converter	320
354. Frequency Changers	321

CHAPTER XL

ELECTRIC TRACTION

355. Tractive Effort	322
356. Speed Time Curve	323
357. Energy Required by a Car	326
358. Characteristics Desired in Railway Motors	327
359. Motor Construction	329
360. Distribution to the Cars	329
361. Alternating- and Direct-current Traction	329
362. Motor Car Trains	332
363. Electric Locomotives	332
364. Crane and Hoist Motors	332
365. Braking	333
366. Flywheel Motor-generator Sets for Mine Hoisting	335
367. Safety Devices	337

CHAPTER XLI

TRANSMISSION AND DISTRIBUTION

368. Direct-current Stations	338
369. Alternating-current Stations	339
370. The Voltages Used in Practice	341
371. Comparison between Single-phase and Three-phase Transmission.	341
372. Lightning Arresters	343
373. Switches	345
374. Overhead Line Construction	346
375. Underground Construction	347
376. Switchboards	348
377. Instrument Transformers	351

CHAPTER XLII

ELECTRIC LIGHTING

378. The Carbon Incandescent Lamp	352
379. The Tungsten Lamp	352
380. Gas-filled Tungsten Lamp	353
381. The Unit of Light	354
382. Arc Lamps	354
383. The Direct-current Open Arc	355
384. Direct-current Enclosed Arc.	355

Article	Page
385. Alternating-current Enclosed Arc	356
386. Flame Arc Lamps	356
387. Luminous Arc Lamp	357
388. Mercury Vapor Converter	357
389. Mercury Vapor Lamp	359
390. Shades and Reflectors	359
391. Efficiency of Illuminants	360
392. Light and Sensation	361
393. Reflection and Color	362
394. Principles of Illumination	362
395. Quality of the Light	363
396. Glare	363
397. Shadows	363
398. Intensity of Illumination	364
399. Lines of Illumination	364
400. Power Distribution for Lighting	365

CHAPTER XLIII

LABORATORY COURSE

401. Protection of Circuits	368
402. Ammeter Shunts	368
403. Safe Carrying Capacity of Copper Wires	368
404. Control of the Current in a Circuit	369
Exp. 1. Measurement of the Resistance of the Field Coil Circuit	370
Exp. 2. Measurement of the Resistance of the Armature Circuit	370
Exp. 3. Speed Adjustment of a Direct-current Shunt Motor	371
Exp. 4. Voltage of a Direct-current Generator	371
Exp. 5. Regulation of Direct-current Generators	372
Exp. 6. Brake Tests on Direct-current Motors	373
Exp. 7. Starting Torque Tests on Direct-current Motors	373
Exp. 8. Stray Loss and Efficiency of a Direct-current Motor	374
Exp. 9. Heat Run on a Direct-current Generator	374
Exp. 10. Voltage Regulation of a Three-wire System	374
Exp. 11. Fuse Testing	375
Exp. 12. Calibration of a Circuit Breaker	375
Exp. 13. Alternating-current Series Circuit	376
Exp. 14. Predetermination of the Characteristics of an Alternating Current Circuit	376
Exp. 15. Characteristics of a Constant Potential Transformer	377
Exp. 16. Regulation of an Alternator	377
Exp. 17. Starting and Running Characteristics of a Synchronous Motor	378
Exp. 18. Characteristics of a Rotary Converter	379
Exp. 19. Starting and Running Characteristics of a Polyphase Induc- tion Motor	380
Exp. 20. Transformer Connections	381
INDEX	383

INTRODUCTORY

Before a study of electric circuits and machinery can be made, it is necessary to define the electric and the magnetic units and express them in terms of the fundamental units and derived mechanical units which are given below.

Quantity	Practical units c.g.s. system	Practical units ft. lb. sec. system
Length	1 cm.	1 ft = 30.48 cm.
Mass	1 gm.	1 lb = 453.6 gm.
Time	1 sec.	1 sec.
Force	1 dyne	1 poundal = 1/32.2 lb.
	1 gm. = 981 dynes	1 lb. = 4.448 × 10 ⁵ dynes
Work or energy	1 erg = 1 dyne cm.	1 ft. lb. = 1.356 × 10 ⁷ ergs
Power	1 erg per sec.	1 h.p. = 550 ft. lb. per sec. = 746 × 10 ⁷ ergs per sec.

In the first few chapters of this work some of the fundamental principles of electricity and magnetism are briefly discussed. Parts of these chapters are difficult and are of theoretical importance only. These are printed in small type and may be omitted if the student is willing to consider as experimental laws what are really laws depending on the definitions of the electric and the magnetic units and on their interrelations.

PRINCIPLES AND PRACTICE OF ELECTRICAL ENGINEERING

CHAPTER I

MAGNETISM AND MAGNETIC UNITS

1. **Magnets.**—The power of a magnet to attract or repel is concentrated at certain points called poles. A simple magnet has two poles which are equal and opposite and the line joining them points north and south when the magnet is allowed to swing freely in a horizontal plane. The pole pointing toward the north is called the north (*N*) pole, that pointing toward the south is called the south (*S*) pole.

Like poles repel one another, unlike poles attract one another.

2. **Coulomb's Law** states that the force between two magnetic poles is directly proportional to the strengths of the poles and inversely proportional to the square of the distance between the poles, thus, in Fig. 1,

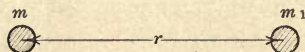

FIG. 1.

$$f = k \frac{mm_1}{r^2}$$

where f is the force between the poles,

r is the distance between the poles,

m and m_1 are the strengths of the poles,

k is a constant which depends on the surrounding medium and on the units chosen.

The c.g.s. unit of pole strength is chosen so as to make $k = 1$ when f is in dynes, r in cm. and the medium is air, then $f = \frac{mm_1}{r^2}$.

A unit pole therefore acts on an equal pole in air, at a distance of 1 cm. from it, with a force of 1 dyne.

3. **The magnetic field** is the name given to the space surrounding a magnet, but is limited in practice to the space within which the force of the magnet is perceptible. A magnetic pole placed in a magnetic field is acted on by a force which is proportional

to the strength of the magnetic pole and to the strength or intensity of the magnetic field.

The intensity of a magnetic field at any point is taken as the force in dynes on a unit pole at that point; therefore, a unit field will act on a unit pole in air with a force of 1 dyne.

The direction of a magnetic field at any point is taken as the direction of the force on a north pole at that point.

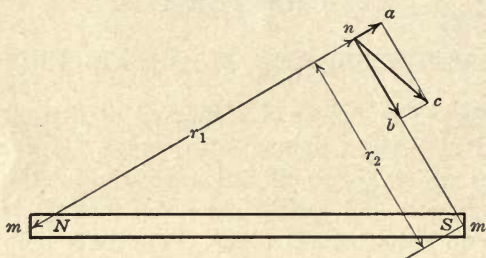

FIG. 2.—Direction of the field of a magnet.

Let NS , Fig. 2, be a magnet of pole strength m , and n a unit north pole. The pole N of the magnet repels the unit pole with a force $= m/r_1^2$ dynes, represented in magnitude and direction by the line na ; the pole S of the magnet attracts the unit pole with a force $= m/r_2^2$ dynes, represented in magnitude and direction by the line nb ; the resultant force on the unit pole, which is a measure of the field intensity, is represented in magnitude and direction by the line nc .

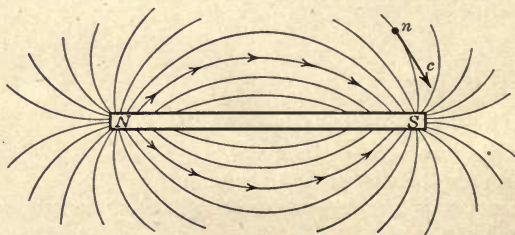

FIG. 3.—Lines of force surrounding a bar magnet.

4. Lines of Force.—In dealing with magnetic problems it is found convenient to represent the magnetic field diagrammatically by what are called lines of force. These are continuous lines whose direction at any point in the field is that of the force on a north pole placed at the given point. The number of lines crossing 1 sq. cm. placed perpendicularly to this direction is made proportional to the field intensity at the point and unit magnetic field is represented by one line per sq. cm.

In Fig. 3 the intensity of the magnetic field is greatest at the poles and decreases as the distance from the poles increases, so that the lines of force which represent this field spread out from the poles as shown. Since a north pole n placed in this field is repelled by the pole N and attracted by the pole S , the lines of force, being drawn in the direction of the force on a north pole placed in the field, must leave the N pole and enter the S pole.

The total number of lines of force leaving or entering a magnetic pole is called its magnetic flux ϕ .

The flux density \mathfrak{B} at any point in a magnetic field is the number of lines of force crossing unit area placed perpendicular to the direction of the lines of force at that point.

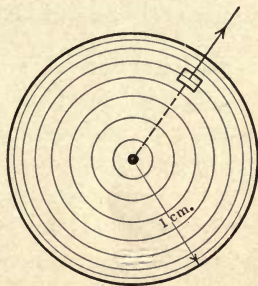

FIG. 4.

5. Lines of Force from a Unit Pole.—If a unit pole were surrounded by a sphere of 1 cm. radius, as in Fig. 4, another unit pole placed on the surface of this sphere would be acted on with unit force and so the field intensity at this surface must be unity; there must therefore be one line of force per sq. cm. of sphere surface or a total of 4π lines, as the surface area of a sphere of 1 cm. radius is 4π sq. cm.

Since the number of lines from a unit pole is 4π , therefore the number from a pole of strength m is $4\pi m$.

CHAPTER II

ELECTROMAGNETISM

6. **Direction of an Electric Current.**— P and Q , Fig. 5, are conductors carrying current; the current is going down in conductor P and coming up in conductor Q . Let the direction of the current be represented by an arrow; at the end of conductor P one would see the tail of the arrow, represented by a cross, while at the end of conductor Q the point of the arrow would be seen, this is represented by a dot.

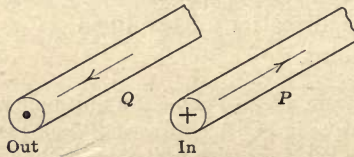

FIG. 5.—Direction of an electric current.

7. **Magnetic Field Surrounding a Conductor Carrying Current.**—A conductor carrying current is surrounded by a magnetic field represented by lines of force as shown in Fig. 6. To deter-

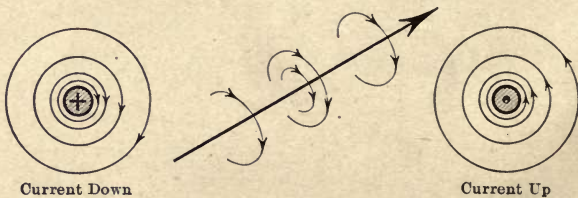

FIG. 6.—Field surrounding a conductor carrying current.

mine the direction of these lines the following rule is used: If a corkscrew is screwed into the conductor in the direction of the current then the head of the corkscrew has to be turned in the direction of the lines of force.

8. **Force at the Centre of a Circular Loop Carrying Current.**—Fig. 7 shows a wire, carrying a current i , and bent to form a circular loop of radius r . The direction of the magnetic field produced is found by the rule in the last paragraph.

An element ab acts on a unit pole at the centre of the loop with a force f which is found to be $= k \frac{ab \times i}{r^2}$, and the total force F on this pole due to the complete loop

$$\begin{aligned} &= k \frac{2\pi r \times i}{r^2} \\ &= k \frac{2\pi i}{r} \end{aligned}$$

where k is a constant which depends on the medium and on the units chosen. The unit of current is chosen so as to make $k = 1$ when F is in dynes, r is

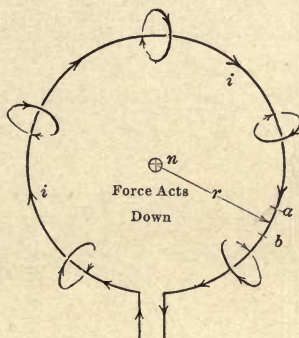

FIG. 7.—Magnetic field produced by a loop carrying current.

in cm. and the medium is air, then $F = \frac{2\pi i}{r}$ dynes; a unit current is therefore of such value that, when flowing in a loop of 1 cm. radius, it acts on a unit pole at the centre of the loop with a force of 2π dynes. This is called the c.g.s. unit of current; the practical unit, called the ampere, is equal to one-tenth of a c.g.s. unit.

9. Electromagnets.—The loop carrying current, shown in Fig. 7, acts like a magnet and is called an electromagnet. The

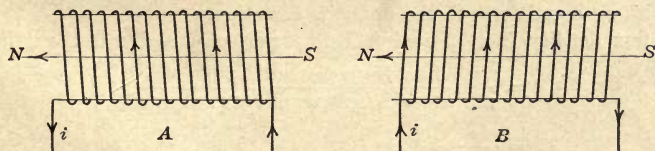

FIG. 8.—The polarity of an electromagnet.

strength of an electromagnet may be increased by increasing the current or, as in Fig. 8, by increasing the number of turns. The direction of the magnetic field may be conveniently found by another corkscrew law which states that if the head of the work screw is turned in the direction of the current then the screw-

itself will move into the magnetic field in the direction of the lines of force; the direction of the field produced by the right-hand spiral in diagram *A* is the same as that produced by the left-hand spiral in diagram *B*; this direction may be reversed by reversing the current.

10. Force on a Conductor Carrying Current in a Magnetic Field.—In Fig. 9, the unit pole n is acted on by the current in the loop with a force of

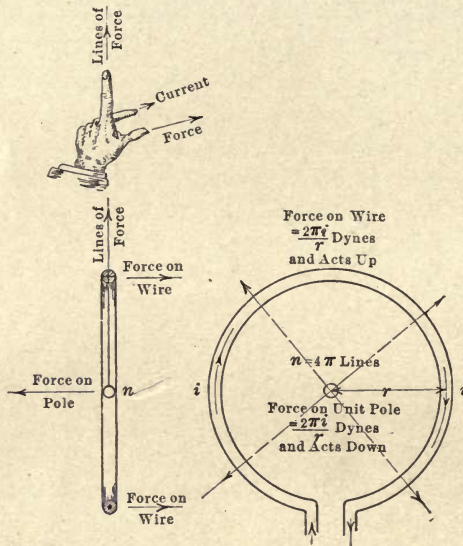

FIG. 9.—Force on a conductor carrying current in a magnetic field.

$2\pi i/r$ dynes (page 5) at right angles to the plane of the paper, where i is the current in c.g.s. units. The loop itself must be reacted on by the unit pole with an equal force in the opposite direction.

The flux density \mathcal{B} at the wire, in lines per sq. cm., due to the unit pole

$$\begin{aligned}
 &= \frac{\text{flux from the unit pole}}{\text{surface of a sphere of } r \text{ cm. radius}} \\
 &= \frac{4\pi}{4\pi r^2} = \frac{1}{r^2}
 \end{aligned}$$

As shown above, the force acting on the wire in dynes

$$\begin{aligned}
 &= \frac{2\pi i}{r} \\
 &= \frac{1}{r^2} \times 2\pi r \times i \\
 &= \mathcal{B} Li.
 \end{aligned}$$

$$\text{Since } \mathcal{B} = \frac{i}{r^2}$$

where \mathcal{B} is the flux density at the wire in lines per sq. cm., L is the length of wire that is in the magnetic field in cm. = $2\pi r$ in the case of a circular loop i is the current in the wire in c.g.s. units.

When a conductor is carrying current and is in a magnetic field, as in Fig. 10, it is acted on by a force which is proportional

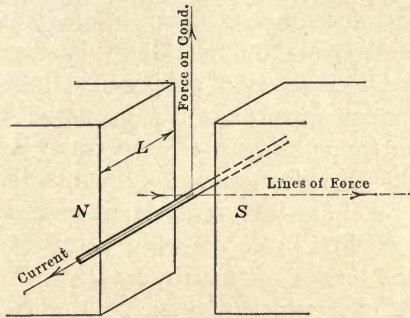

FIG. 10.—Force on a conductor carrying current in a magnetic field. Left Hand Ruel: thumb—force; forefinger—lines of force; middle finger—current.

to the current and to the strength of the field. The direction of this force may be determined by what is called the **left-hand rule** which states that if the thumb, the forefinger and the

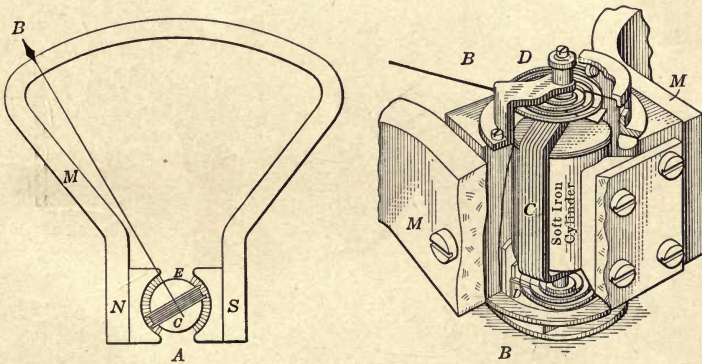

FIG. 11.—Moving coil ammeter.

middle finger of the left hand are placed at right angles to one another as in Fig. 9 so as to represent three coordinates in space, with the thumb pointed in the direction of the mechanical force and the forefinger in the direction of the lines of force, then the middle finger will point in the direction of the current.

11. Moving Coil Ammeters.—The above principle is applied in one of the most satisfactory types of instrument for the measurement of direct current.

Such an instrument is shown in Fig. 11. NS' is a permanent horseshoe magnet with pole shoes bored out cylindrically and E is a cylindrical soft iron core concentric with the pole faces, lines of force therefore pass as shown in diagram A and the flux density in the air gaps is uniform. In this magnetic field a coil C is placed and is supported on jewelled bearings. The coil consists of a number of turns of fine insulated wire wound on a light aluminium frame and the current to be measured is introduced to the coil through the spiral springs D , diagram B . Since the sides of the coil are carrying current and are in a magnetic field they are acted on by forces which turn the coil through an angle against the torsion of the springs D and this angle may be read on a scale over which plays a pointer B attached to the coil.

CHAPTER III

ELECTROMAGNETIC INDUCTION

12. Electromagnetic Induction.—Faraday's experiments showed that when the magnetic flux threading a coil undergoes a change, an electromotive force (e.m.f.) is generated or induced in the coil and that this e.m.f. is proportional to the time rate of change of the flux. If the coil *A*, Fig. 12, be moved from position 1 where the flux threading the coil is ϕ lines, to position 2 where the flux threading the coil is zero, in a time of t seconds, then the average rate of change of flux is ϕ/t lines per sec.

The c.g.s. unit of e.m.f. is that generated in a coil of one turn when the flux threading the coil is changing at the rate of one line per sec. The practical unit, called the volt, is equal to 10^8 c.g.s. units so that when the flux threading a coil of one turn changes at the rate of ϕ lines in t seconds the average e.m.f. induced in the coil = $\frac{\phi}{t} 10^{-8}$ volts and

the e.m.f. at any instant = $\frac{d\phi}{dt} 10^{-8}$ volts.

That portion of the coil wherein the e.m.f. is actually induced is the conductor xy which cuts the lines of force, and the quantity $d\phi/dt$ is the rate at which the lines are cut.

13. The direction of the induced electromotive force may be determined by Fleming's three-finger **right-hand rule** which states that if the thumb, the forefinger and the middle finger of the right hand be placed at right angles to one another so as to

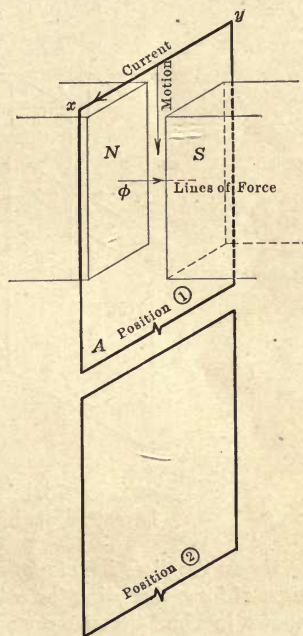

FIG. 12.—Generation of electromotive force. Right Hand Rule: thumb—motion; fore-finger—lines of force; middle finger—electromotive force.

represent three coordinates in space, with the thumb pointed in the direction of motion of the conductor relative to the magnetic field and the forefinger in the direction of the lines of force, then the middle finger will point in the direction of the induced e.m.f.

The direction of the current in xy , as determined by the right-hand rule, is shown in Fig. 13 for the case where the coil is moving downward and the number of lines of force threading the coil is decreasing. This current sets up a magnetic flux ϕ_c , the direction of which, found by the corkscrew law (page 5) is the same as that of the main flux ϕ and tends to prevent the flux threading the coil from decreasing.

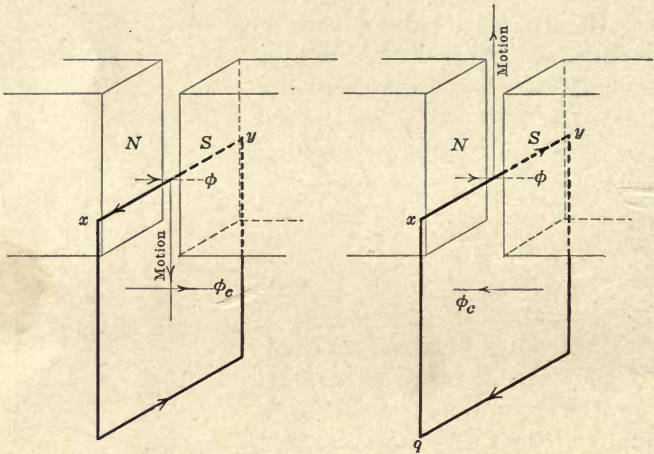

FIG. 13.

FIG. 14.

Direction of the generated electromotive force.

If now the direction of motion of the coil be reversed so that the number of lines of force threading the coil is increasing, the current will be reversed, as shown in Fig. 14, and the magnetic flux ϕ_c will oppose the main flux ϕ and tend to prevent the flux threading the coil from increasing.

The general law for the direction of the induced e.m.f. in a coil, known as *Lenz's Law*, states that the induced e.m.f. tends to send an electric current in such a direction as to oppose the change of flux which produces it.

If the coil $abcd$, Fig. 15, is moved from m to n , the flux threading the coil does not change and the resultant e.m.f. generated in the coil is zero; the portions ab and cd of the coil are cutting lines of force but the e.m.fs. generated in these portions are equal and opposite.

14. Mutual Induction.—The flux threading a coil may be changed without moving the coil. Suppose a constant current is flowing in the coil *A*, Fig. 16, this produces a constant flux ϕ which threads coils *A* and *B* but no e.m.f. is generated in coil *B* since there

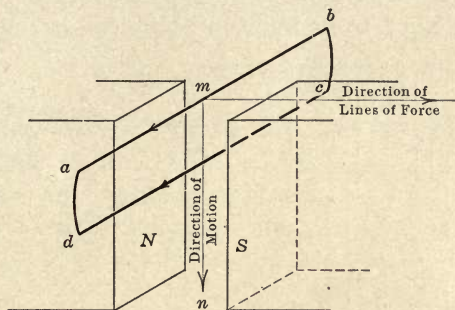

FIG. 15.

is no change in the flux. If the current in coil *A* is increased, the flux threading coil *B* will increase and this change of flux will induce an e.m.f. in coil *B* which will cause a current I_2 to flow in such a direction as to oppose the increase in flux. If the current in coil *A* is decreased, the flux threading coil *B* will decrease and this change of flux will induce in coil *B* an e.m.f. which will send a current I_2 in such a direction as to oppose the decrease in flux.

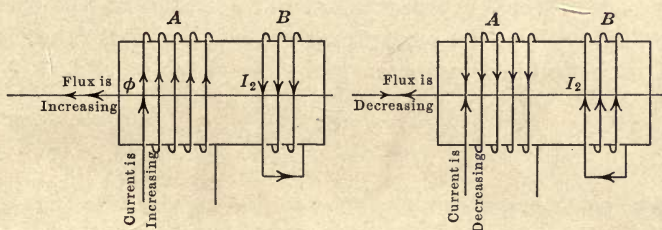

FIG. 16.—Direction of electromotive force of mutual induction.

15. Self Induction.—When the current in a coil is changed, an e.m.f. is generated in the coil itself in such a direction as to oppose the change in the current. In Fig. 17, for example, when the switch *k* is closed, the current flowing in the coil does not reach its final value instantaneously because, as the current increases in value, the flux ϕ threading the coil increases and causes an e.m.f. to be induced in the coil in such a direction as to oppose the in-

crease of the current. This opposing e.m.f., called the e.m.f. of self induction, exists only while the current is changing.

If, after the current has reached its final value, the switch k is suddenly opened, the current in the coil tries to decrease suddenly to zero but, as it decreases, the flux threading the coil decreases and causes an e.m.f. to be induced in the coil in such a direction

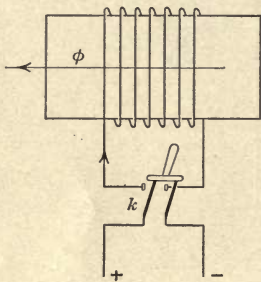

FIG. 17.

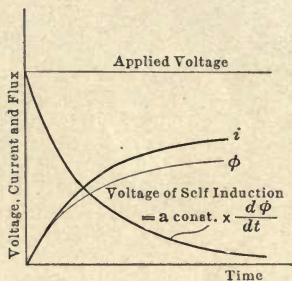

FIG. 18.—Growth of current in a coil.

as to oppose the decrease of the current; this e.m.f. is generally large enough to maintain the current between the switch contacts as they are being separated and accounts for much of the flashing that is seen when a switch is opened in a circuit carrying current.

When the switch is closed, the current increases to its final value as shown in Fig. 18. As the current i increases, the corresponding increase of the flux ϕ threading the coil induces an e.m.f. of self induction which is proportional to $d\phi/dt$, the rate of change of the flux. When the current has ceased to change, the e.m.f. of self induction becomes zero.

CHAPTER IV

WORK AND POWER

16. Transformation of Mechanical into Electrical Energy.— If the conductor xy , Fig. 19, be moved downward so as to cut at a constant rate the lines of force passing from N to S , a constant e.m.f. is induced in the conductor and, by adjusting the resistance R , the current in the circuit may be maintained at the value i

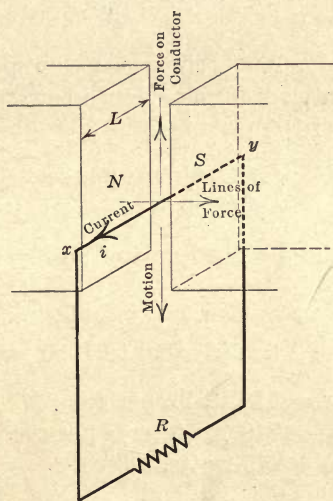

FIG. 19.

Right Hand Rule for generation of e.m.f.: thumb—motion; forefinger—lines of force; middle finger—e.m.f.

Left Hand Rule for direction of force: thumb—force on conductor; forefinger—lines of force; middle finger—current.

in the direction shown; the direction of the current may be determined by the right-hand rule (page 9).

As this conductor is carrying current in a magnetic field, it is acted on by a force F the direction of which may be determined by the left-hand rule (page 7). This force, as shown in Fig. 19, opposes the motion of the conductor and hence mechanical energy must be expended in moving the conductor.

If \mathcal{B} is the density of the magnetic field in lines per sq. cm.
 L is the length in cm. of that part of the conductor which is cutting lines of force

V is the velocity of the conductor in cm. per sec.

i is the current in the conductor in c.g.s. units, then

e , the e.m.f. generated in the conductor in c.g.s. units,

= the lines of force cut per sec.

= $\mathcal{B}LV$

Now F , the force acting on the conductor = $\mathcal{B}Li$ dynes (page 6) and the mechanical power in dyne cm. per sec. required to keep the conductor moving

= FV

= $(\mathcal{B}Li)V$

= $(\mathcal{B}LV)i$

= ei

= (volts $\times 10^8$)(amperes/10); pages 9 and 5

= volts \times amperes $\times 10^7$

The mechanical power required to obtain I amperes at a difference of potential of E volts from an electrical machine which has an efficiency of 100 per cent.

= $EI 10^7$ ergs per sec.

= EI watts

where the watt, the practical unit of power, is equal to 10^7 ergs per second.

The power developed by large electrical machines is expressed in kilowatts, where 1 kw. is equal to 1000 watts.

The horsepower = 550 ft. lb. per sec.

= 746×10^7 ergs per sec.

= 746 watts.

this result gives a connecting link between the electrical and the mechanical units.

17. Unit of Work.—Work is done when a force is moved through a distance. The c.g.s. unit of work is the erg, which is the work done in moving a force of 1 dyne through a distance of 1 cm.

Power is the rate at which work is done and is expressed either in ergs per sec., in watts (10^7 ergs per sec.), or in horsepower (746×10^7 ergs per sec.).

When the power, or rate at which work is being done, is 1 watt, or 10^7 ergs per sec., then the work done in 1 sec. is 1 watt-second or 10^7 ergs and is called 1 joule. A more

convenient unit for practical work is the kilowatt-hour (3600×10^3 joules) and this will gradually replace the horsepower-hour because it is based on a system of international units.

18. Heat Energy and Electrical Energy.—The energy required to raise the temperature of 1 lb. of water by 1° F. is called the British Thermal Unit (B.T.U.) and is equal to 780 ft. lb. The energy required to raise 1 gm. of water through 1° C. is called the gramme calorie and is equal to 4.2×10^7 ergs so that

$$\begin{aligned} 1 \text{ gm. calorie} &= 4.2 \times 10^7 \text{ ergs} \\ &= 4.2 \text{ watt-seconds (joules)}. \end{aligned}$$

19. Conversion Factors.—Although the c.g.s. system of units is the only possible international system, much calculation work is still carried out in the foot-pound-second system. The conversion factors given below help to simplify the work of changing from one system to another.

	C.g.s. unit	Other units
Length	1 cm.	1 in. = 2.54 cm.
Mass	1 gm.	1 lb. = 453.6 gm.
Time	1 sec.	
Force	1 dyne	1 gm. = 981 dynes 1 lb. = 444,800 dynes = 453.6 gm.
Work or energy	1 erg = 1 dyne-cm.	1 joule = 1 watt-sec. 10 ⁷ ergs 1 ft. lb. = 1.356×10^7 ergs 1 kw.-hour = 3600×10^3 joules 1 gm. calorie = 4.2 joules 1 lb. calorie = 1900 joules
Power	1 erg. per sec.	1 watt = 10 ⁷ ergs per sec. 1 kw. = 1000 watts 1 h.p. = 550 ft. lb. per sec. = 746 watts

20. Problems on Work and Power.

1. A hoist raises a weight of 2000 lb. through a distance of 300 ft. in a time of 1 min. Find the work done and the power expended.

If the efficiency of the hoist is 75 per cent. and that of the motor is 90 per cent. find the horsepower of the motor and also the current taken by the motor if the voltage is 110.

$$\begin{aligned} a. \text{ Work done} &= 2000 \times 300 \\ &= 600,000 \text{ ft. lb.} \end{aligned}$$

$$\begin{aligned}
 \text{b. Power expended} &= 600,000 \text{ ft. lb. per 60 sec.} \\
 &= 10,000 \text{ ft. lb. per sec.} \\
 &= \frac{10,000}{550} = 18.2 \text{ h.p.} \\
 &= \frac{18.2 \times 746}{1000} = 13.6 \text{ kw.}
 \end{aligned}$$

$$\begin{aligned}
 \text{c. The power input to the hoist} &= \frac{13.6}{0.75} = 18.1 \text{ kw} = 24.3 \text{ h.p.} \\
 \text{The power input to the motor} &= \frac{18.1}{0.9} = 20 \text{ kw.}
 \end{aligned}$$

d. Since watts = volts \times amperes, therefore $20 \times 1000 = 110 \times$ amperes and the current in amperes = 182.

2. An electric iron takes 5 amp. at 110 volts. What does it cost to operate this iron for 2 hours if the cost of energy is 6 cents per kw.-hour.

$$\begin{aligned}
 \text{The rate at which energy is used} &= 110 \times 5 = 550 \text{ watts} \\
 &= 0.55 \text{ kw.}
 \end{aligned}$$

$$\text{The energy used in 2-hours} = 0.55 \times 2 = 1.1 \text{ kw.-hour}$$

$$\text{The cost of this energy} = 1.1 \times 6 = 6.6 \text{ cents}$$

3. A 32-candle power, 110-volt tungsten lamp requires 40 watts. What is the current taken by this lamp and what is the cost of energy for 15 lamps burning for an average time of 4 hours if the cost of energy is 5 cents per kw.-hour?

$$\text{amperes} = \frac{\text{watts}}{\text{volts}} = \frac{40}{110} = 0.36 \text{ amp.}$$

$$\begin{aligned}
 \text{power} &= 40 \times 15 = 600 \text{ watts} \\
 &= 0.6 \text{ kw.}
 \end{aligned}$$

$$\text{energy used} = 0.6 \times 4 = 2.4 \text{ kw.-hours}$$

$$\text{cost of energy} = 2.4 \times 5 = 12 \text{ cents.}$$

4. An electric water heater has an efficiency of 80 per cent. and takes 3 amp. at 110 volts. How long will it take to raise 1 pint (1.25 lb.) of water from 20° C. to the boiling point and what will this cost when the rate is 5 cents per kw.-hour?

$$\begin{aligned}
 \text{energy required} &= 1.25 (100 - 20) = 100 \text{ lb. calories} \\
 &= 100 \times 1900 = 190,000 \text{ watt-sec.}
 \end{aligned}$$

$$\begin{aligned}
 \text{energy delivered} &= 190,000 \times \frac{100}{80} \\
 &= 238,000 \text{ watt-sec.} \\
 &= 238 \text{ kw.-sec.} \\
 &= 0.066 \text{ kw.-hours}
 \end{aligned}$$

$$\text{cost of energy} = 0.066 \times 5 = 0.33 \text{ cents}$$

Now 238,000 watt-sec. are supplied at the rate of $110 \times 3 = 330$ watts therefore the time during which energy must be applied

$$\begin{aligned}
 &= \frac{238,000}{330} = 720 \text{ sec.} \\
 &= 12 \text{ min.}
 \end{aligned}$$

5. If a ton (2000 lb.) of coal heats a house for a month what would it cost to give exactly the same heating effect electrically if the cost of energy is 3 cents per kw.-hour?

With a good heating system 1 lb. of coal burnt on the grate will deliver 8000 B.T.U. or 4450 lb. calories to the house.

$$\begin{aligned} \text{The energy required per month therefore} &= 4450 \times 2000 \text{ lb. calories} \\ &= 8,900,000 \text{ lb. calories.} \\ &= 8,900,000 \times 1900 \text{ watt-sec.} \\ &= \frac{8,900,000 \times 1900}{3600 \times 1000} \text{ kw.-hours} \end{aligned}$$

$$= 4,700 \text{ kw.-hours}$$

$$\text{the cost of this energy} = 4,700 \times 3 = 14,100 \text{ cents}$$

$$= 141 \text{ dollars.}$$

The reason for this enormous difference in the cost of heating by the two methods is that the efficiency of a heating system is about 60 per cent. while that of an electric generating station is about 6 per cent.; moreover the cost of the coal required per kw.-hour is about 0.5 cents or 1/6 of the selling price of the electrical energy.

CHAPTER V

ELECTRIC CIRCUITS AND RESISTANCE

21. The flow of electricity through electric circuits is similar in many ways to the flow of water through hydraulic circuits. This may be seen by a comparison between the circuits shown diagrammatically in Fig. 20.

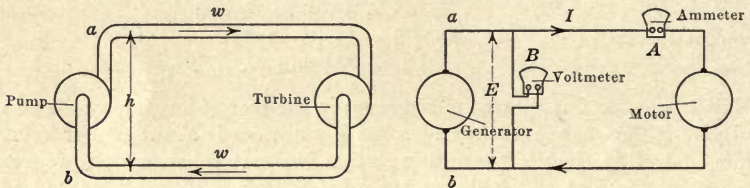

Fig. 20.—Hydraulic and electric circuits.

To maintain a steady current of w gm. of water per sec. through the hydraulic circuit and to raise the water from b to a through a difference of potential of h cm., an amount of power = wh gm. cm. per sec. must be put into the circuit by the pump.

In returning from a to b through the external part of the circuit, the water falls through a difference of potential of h cm. and supplies an amount of power = wh gm. cm. per sec. to drive the turbine and to supply the frictional resistance loss in the pipes.

To maintain a steady electric current of I coulombs per sec. (amperes¹) through the electric circuit and to raise the electricity through a difference of potential of E volts, an amount of power = EI watts must be put into the circuit by the electric generator.

In returning from a to b through the external part of the circuit, the electricity falls through a difference of potential of E volts and supplies an amount of power = EI watts to drive the motor and to supply the resistance loss in the connecting wires.

¹A current of electricity is expressed in amperes; there is no corresponding unit for a current of water which must therefore be expressed in gm. cm. per sec. The quantity of electricity which passes any point in a circuit is expressed in coulombs where 1 coulomb is 1 amp.-sec. A larger unit is the ampere-hour.

The current of water (the quantity passing any point per sec.) is the same at all points in the circuit since the circuit is closed.

The electric current (the quantity passing any point per sec.) is the same at all points in the circuit since the circuit is closed.

22. Ammeters and Voltmeters.—The current in a circuit may be measured by means of an instrument such as that described on page 8, connected directly in the circuit as shown at *A*, Fig. 20, while the difference of potential between two points may be measured by means of a similar instrument connected directly between the points as shown at *B*. The essential difference between the two instruments is that the ammeter must carry the total current in the circuit with only a small difference of potential across its terminals and must therefore offer a small resistance to the flow of current through it, the voltmeter on the other hand must divert only a small portion of the current from the circuit and must therefore offer a large resistance to the flow of current through it.

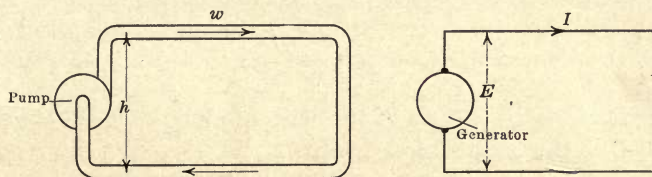

FIG. 21.—Hydraulic and electric circuits.

23. Resistance Circuits.—Consider the case represented diagrammatically in Fig. 21 where there is no turbine in the hydraulic circuit nor any motor in the electric circuit.

The difference of potential of h em. maintained by the pump is used up in forcing w gm. of water per sec. against the frictional resistance of the pipe, and

$$h = wr$$

where r is called the resistance of the pipe circuit.

The difference of potential of E volts maintained by the electric generator is used up in forcing I amperes against the resistance of the wires, and

$$E = IR$$

where R is called the resistance of the electric circuit and is a constant for a given circuit.

This resistance increases with the length and decreases with the cross section of the pipe.

This resistance increases with the length and decreases with the cross section of the wire, or

$$R = k \frac{\text{length}}{\text{section}}$$

24. Ohm's Law.—The above relation $E = IR$ is known as Ohm's law and the unit of resistance, called the ohm, is chosen of such a value that a circuit with a resistance of 1 ohm will allow 1 amp. to flow when the difference of potential between the ends is 1 volt, therefore

$$\text{volts} = \text{amperes} \times \text{ohms}$$

If for example the current in the heating coil of a 110-volt electric iron is 5 amp., then the resistance of this coil = $110/5 = 22$ ohms.

25. Specific Resistance.—As pointed out in art. 23, the resistance of a wire is directly proportional to its length and inversely proportional to its cross section or

$$R = k \frac{L}{A}$$

where R is the resistance of the wire in ohms

L is the length of the wire

A is the cross section of the wire

k is a constant called the specific resistance and depends on the material and on the units chosen. If centimeter units are used then the specific resistance is the resistance of a piece of the material 1 cm. long and 1 sq. cm. in cross section and is expressed in ohms per cm. cube.

In practice the unit of cross section is generally taken as the circular mil which is defined as the cross section of a wire 1 mil (1/1000 in.) in diameter.

Since a wire 1 mil in dia. has a section of 1 cir. mil a wire 1 inch in dia. has a section of 10^6 cir. mils and a wire 1 sq. inch in section has a section of $\frac{4}{\pi} 10^6$ cir. mils.

The specific resistance of copper wire¹ is 1.6×10^{-6} ohms per cm. cube or 9.7 ohms per cir. mil foot at 0° C.; the specific

¹For values of specific resistance of various materials see Standard Handbook for Electrical Engineers.

resistance of cast iron is 80×10^{-6} ohms per cm. cube or 480 ohms per cir. mil foot, approx., at 0°C .

26. Variation of Resistance with Temperature.—The resistance of most materials varies with the temperature and

$$R_t = R_0(1 + \alpha t)$$

where R_t is the resistance at $t^\circ \text{C}$.

R_0 is the resistance at 0°C .

t is the temperature of the material in deg. C.

α is called the temperature coefficient of resistance.

For all pure metals the resistance increases with the temperature and α is approximately equal to 0.004. The resistance of carbon and of liquid conductors decreases with increase of temperature, while the resistance of special alloys such as manganin remains approximately constant at all operating temperatures.

A coil has 1000 turns of copper wire with a cross section of 1288 cir. mils and a length of mean turn of 15 in.

- Find the resistance of the coil at 0°C .
- Find the resistance of the coil at 25°C .
- Find the current that will flow through the coil at 25°C . and 110 volts.
- After current has passed through the coil for some time it is found that its value has dropped to 9 amp., find the average temperature of the coil under these conditions.

a. The resistance of 1 cir. mil foot = 9.7 ohms at 0°C .

$$\text{The resistance of the coil at } 0^\circ \text{C,} = \frac{9.7 \times 1000 \times 15}{1288 \times 12} = 9.4 \text{ ohms.}$$

b. The resistance of the coil at 25°C . = $9.4(1 + 0.004 \times 25) = 10.3$ ohms.

c. The current = $\frac{110}{10.3} = 10.7$ amp.

d. The hot resistance of the coil = $\frac{110}{9} = 12.2$ ohms at $t^\circ \text{C}$.

The resistance of the coil also = 9.4 ohms at 0°C .

Therefore the resistance of the coil at $t^\circ \text{C}$. = $9.4(1 + 0.004t)$
= 12.2 ohms

from which $1 + 0.004t = 12.2/9.4 = 1.3$.

and $t = 0.3/0.004 = 75^\circ \text{C}$.

27. Power Expended in a Resistance.—To force a current of I amperes through a circuit which has a resistance of R ohms, a voltage $E = IR$ is required so that

$$\begin{aligned} \text{the power expended in the circuit} &= EI \text{ watts} \\ &= (IR)I \\ &= I^2R \text{ watts.} \end{aligned}$$

This power is transformed into heat.

In the electric flat iron and other such heating apparatus this heat is utilized, the heating element consisting of a coil of high resistance wire, insulated with heat resisting insulation such as asbestos, or mica, and embedded in the iron.

28. Insulating materials are materials which offer a very large resistance to the flow of electric current and for that reason they are used to keep the current in its proper path. In a transmission line, current is prevented from passing between the wires by porcelain insulators attached to cross arms as shown in Fig. 22. When the wires are placed close to one another, as in house wiring, they are covered throughout their entire length with insulating material such as paper, rubber or cotton; the electrical resistance of these materials is greater than 10^{10} ohms per cm. cube.

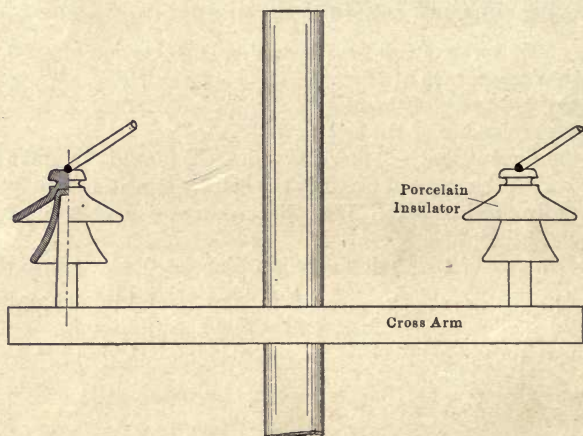

FIG. 22.—Insulators for transmission lines.

29. Dielectric Strength of Insulating Material.—If a sheet of insulating material is placed between two terminals and the voltage between the terminals is gradually raised the material will finally break down and a hole be burnt through it, the material is then said to be punctured, and a large current will flow through the puncture if the voltage is maintained. The property of an insulating material by virtue of which it resists breakdown is called its dielectric strength.

30. Series and Parallel Circuits.—If several conductors are connected in series as shown in Fig. 23, then the current is the

same in each conductor while the total voltage is the sum of the voltages across the different parts of the circuit so that

$$\begin{aligned} E &= E_1 + E_2 + E_3 + E_4 \\ &= I(R_1 + R_2 + R_3 + R_4) \end{aligned}$$

If several conductors are connected in parallel as shown in Fig. 24, then the voltage across each conductor is the same while the total current is the sum of the currents in the different paths so that

$$\begin{aligned} I &= I_1 + I_2 + I_3 + I_4 \\ &= E \left(\frac{1}{R_1} + \frac{1}{R_2} + \frac{1}{R_3} + \frac{1}{R_4} \right) \end{aligned}$$

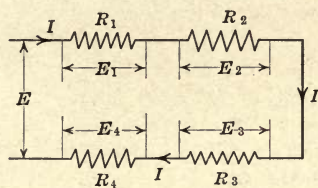

FIG. 23.—Series circuit.

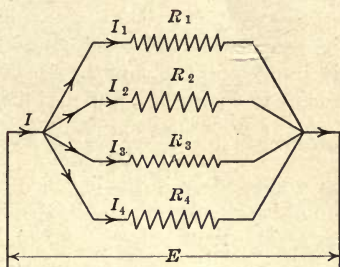

FIG. 24.—Parallel circuit.

Four coils having resistances of 3, 5, 10 and 12 ohms respectively are connected in series across 120 volts, find the current in the circuit and the voltage drop across each coil.

$$\begin{aligned} 120 &= I(3 + 5 + 10 + 12) \\ &= 30I \end{aligned}$$

therefore $I = 4$ amp.

$$E_1 = 4 \times 3 = 12 \text{ volts}$$

$$E_2 = 4 \times 5 = 20 \text{ volts}$$

$$E_3 = 4 \times 10 = 40 \text{ volts}$$

$$E_4 = 4 \times 12 = 48 \text{ volts}$$

If these coils are now connected in parallel across 120 volts, find the current in each coil and also the total current.

$$I_1 = 120/3 = 40 \text{ amp.}$$

$$I_2 = 120/5 = 24 \text{ amp.}$$

$$I_3 = 120/10 = 12 \text{ amp.}$$

$$I_4 = 120/12 = 10 \text{ amp.}$$

total current $I = 86$ amp.

31. Voltage Drop in a Transmission Line.—When electric energy is transmitted from one point to another over wires, a

voltage, called the drop in the line, is required to force the current through the wires. This voltage = IR where R is the total resistance of the connecting wires and I is the current flowing, so that if E_g , Fig. 25, is the voltage at the generating station, and E_r is the voltage applied to the load in the receiving station, then $E_g = E_r + IR$.

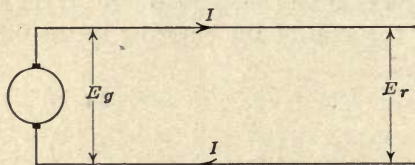

FIG. 25.

The power to be delivered at the end of a 2 mile line is 30 kw. If the receiver voltage is 600, find the size of wire required to limit the voltage drop in the line to 5 per cent., find also the power loss in the line.

$$\text{Current in line} = \frac{30 \times 1000}{600} = 50 \text{ amp.}$$

The voltage drop in the line = 5 per cent. of 600 = 30 volts

The resistance of the wire in the line = $30/50 = 0.6$ ohms

The resistance of copper = 9.7 ohms per cir. mil foot at 0°C .

$$= 9.7 (1 + 0.004 \times 25)$$

$$= 10.6 \text{ ohms per cir. mil foot at } 25^\circ \text{C.}$$

The resistance of 2 miles of line or 4 miles of wire

$$= \frac{10.6 \times 4 \times 5280}{\text{cir. mils}} = 0.6 \text{ ohms}$$

From which cir. mils = 370,000

The loss in the line = 30 volts \times 50 amp.

$$= 1500 \text{ watts}$$

$$= 5 \text{ per cent. of the power delivered.}$$

CHAPTER VI

RHEOSTATS AND RESISTORS

32. Rheostats.—A rheostat is an adjustable resistance of such a form that it can be conveniently used. In the rheostat shown in Figs. 26 and 27, the resistance ab is tapped at eight

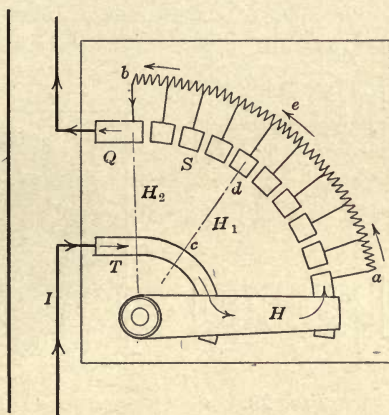

FIG. 26.

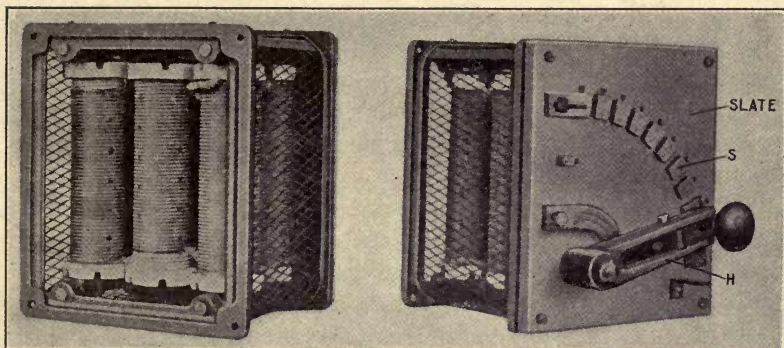

FIG. 27.—Sliding contact type of rheostat.

points which are connected to contact studs s over which the handle H is free to move.

Such a rheostat is used to control the current in a circuit.

When the handle is in the position shown in Fig. 26, all the resistance ab is in the circuit and the current I has its minimum value. When the handle is in the position H_1 , current flows through the path $TcdebQ$ so that the resistance between a and e has been cut out. As the handle is moved further over, the resistance in the circuit is further decreased until finally, when the handle is in the position H_2 , the resistance is all cut out and the current in the circuit has its maximum value.

33. Resistors.—For economy in manufacture, resistances such as ab , Fig. 26, are generally built up of standard resistance

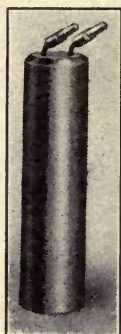

FIG. 30.

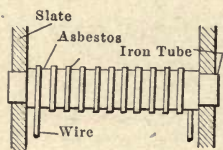

FIG. 28.



FIG. 29.

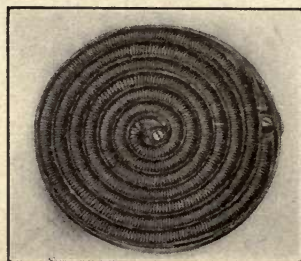

FIG. 31.

Resistance units.

units called resistors, which may be connected in series or in parallel as desired. Different types of resistance units are shown in Figs. 28 to 33.

The unit shown in Fig. 28 consists of a length of wire wound on an iron tube, from which it is insulated by fireproof insulation such as asbestos.

In Fig. 29 a similar unit is shown which consists of a length of wire wound in a spiral groove cut on the surface of a tube of porcelain or some other such material, adjoining turns of the wire being thereby separated from one another.

Such units are mounted in frames as shown in Fig. 27. They are always placed vertically so that air can circulate freely through the tubes and over the surface of the resistance wire and thereby keep the temperature of the rheostat within reasonable limits.

For carrying comparatively small currents, round wire is

suitable; strip metal is preferred for larger currents, as it gives a larger surface for a given section. An excellent type of construction is shown in Fig. 32 where the resistance unit consists of a length of resistance strip metal wound on a frame consisting of an iron plate *A* insulated at the edges with porcelain supporting pieces *B*. These units may be mounted on iron rods which pass through the holes *C*.

34. Heater Units.—Fig. 30 shows the external appearance of a type of resistor which is largely used for electric irons and other such heating appliances. It is constructed of resistance strip wound in the form of a helix and placed in a metal tube which is lined with mica, the tube is then packed with fire-

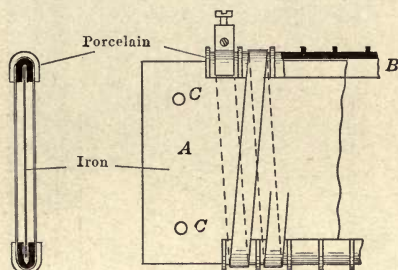

FIG. 32.—Resistance unit.

proof cement to insulate adjacent turns from one another, and the open end of the tube is closed with a cement plug through which the leading in wires are brought.

Another type of heater unit is shown in Fig. 31 and consists of a length of resistance wire wound into a helix of small diameter, which helix is then coiled into a flat spiral and mounted in a frame with mica between the convolutions. This unit is held against a layer of quartz grains which are embedded in enamel on the bottom of the heater.

35. Cast-iron Grid Resistance.—When large currents have to be controlled, the necessary cross section to carry the current and the necessary radiating surface to dissipate the heat are best obtained by the use of zig-zag units of the shape shown in Fig. 33. For small rheostats, these zig-zag pieces may be punched out of sheet metal, but for larger sizes they are generally of cast iron as shown in Fig. 34.

The method of assembling these castings is shown in Fig. 35 which is a plan of a rheostat similar to that in Fig. 34. The units

A are mounted on iron rods *B* which are insulated throughout their entire length by mica or asbestos tubes *C*. The individual units

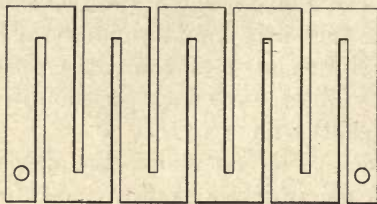

FIG. 33.—Zig-zag resistance unit.

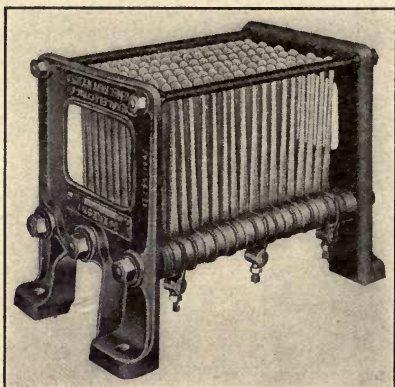

FIG. 34.—Cast-iron grid resistance.

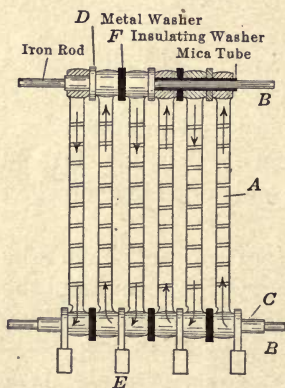

FIG. 35.—Flow of current in a grid resistance.

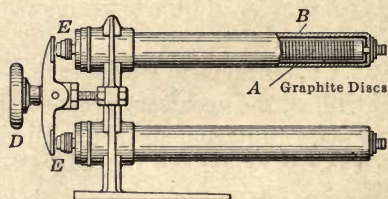

FIG. 36.—Carbon pile rheostat.

are separated from one another by washers which are either of metal as at *D* and *E* or of insulating materials as at *F*, depending

on the direction in which it is desired to make the current flow. The four metal washers *E* act as terminals from which leads can be taken to the contacts on the control faceplate.

36. Carbon Pile Rheostat.—An entirely different type of rheostat is shown in Fig. 36 and consists of a column of graphite discs *A*, enclosed in a steel tube *B* which is lined with fireproof insulation such as asbestos. The resistance of such a pile decreases as the mechanical pressure between the ends increases, because the contact between adjacent discs improves. In the type of rheostat shown in Fig. 36 the pressure is applied by turning the hand-wheel *D* and is communicated to the carbon pile through the plungers *E*. The two units shown may be connected in series or in parallel as desired, and the resistance of such a rheostat can be changed gradually through a total range of about 100 to 1.

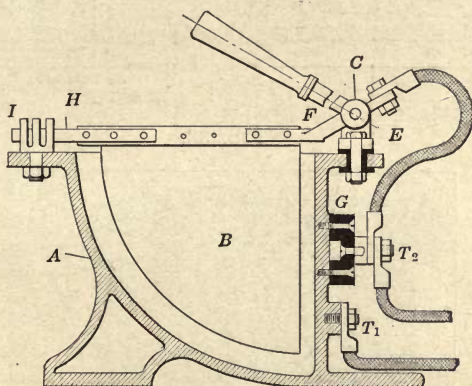

FIG. 37.—Liquid rheostat.

37. Liquid Rheostats.—Such a rheostat is shown in Fig. 37 and consists of a cast-iron trough *A* which contains a solution of caustic soda or some similar material which does not attack iron, and an iron plate *B* which is insulated from the tank as shown at *E* and which dips into the liquid. Between the terminals T_1 and T_2 therefore there is the resistance of the path through the liquid between *A* and *B*, and the section of this path can be increased or decreased by lowering or raising the plate *B*. The resistance may be finally short circuited by lowering *B* far enough to allow the contact *H* to close, then current can pass direct from T_1 to T_2 without passing through the liquid.

Another type of liquid rheostat is shown in Figs. 38 and 39.

In this case the plates are fixed but the level of the liquid is varied. The pump *D* sends a continuous stream of liquid from the cooling chamber *A* through the resistance chamber *B*, and the level of the liquid in this latter chamber may be raised or lowered by a weir *C*.

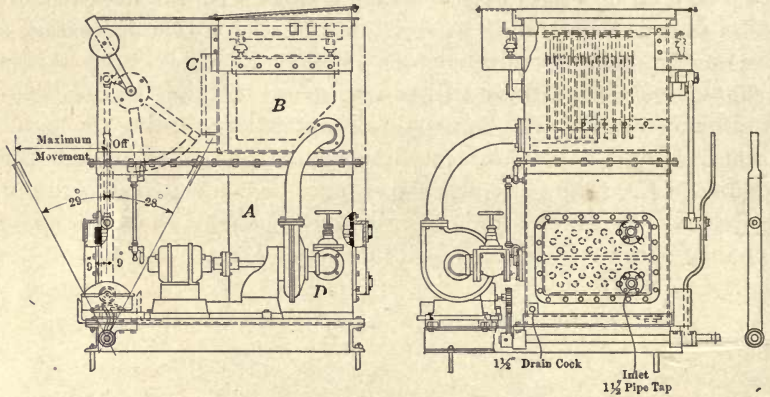

FIG. 38.

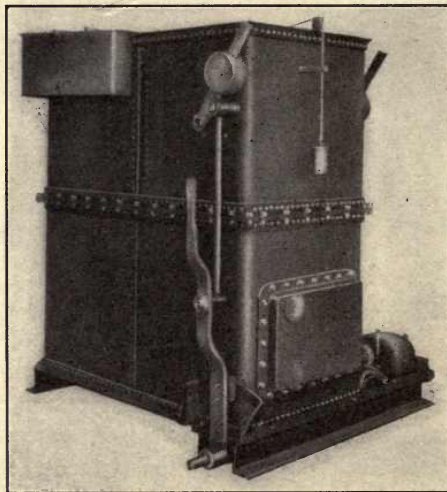

FIG. 39.—Liquid rheostat.

The liquid is cooled in the lower chamber by water which flows through cooling pipes. This cooling chamber sometimes takes the form of a concrete tank made large enough to allow the rheostat to be self cooling.

Liquid rheostats are largely used in making load acceptance tests on generators. Two electrodes in a barrel of water in which a handful of common salt has been dissolved will dissipate about 5 kw. if the water is stationary. The type of temporary rheostat most generally used however consists of a bank of cast-iron grids mounted in a wooden frame and placed in running water, the grids will carry about four times as much current under these conditions as when air cooled.¹

38. The size of a rheostat depends principally on the amount of power which it is required to dissipate. If two rheostats have to dissipate the same amount of power but one has only half as much current flowing as the other then, since the loss in the rheostat = I^2R watts, the former rheostat must have four times the resistance of the latter, that is the wire must have half the section and twice the length, but the weight of wire and the space occupied by the rheostat will be approximately the same in each case.

¹ For design data on such temporary rheostats see the Standard Handbook for Electrical Engineers.

CHAPTER VII

MAGNETIC CIRCUITS AND MAGNETIC PROPERTIES OF IRON

39. Magnetic Field due to a Solenoid.—A solenoid is a coil of wire wound in the form of a helix as shown in Fig. 8, page 5. When an electric current is passed through such a coil it acts as an electromagnet and the direction of the magnetic field may be found by the corkscrew law, page 5.

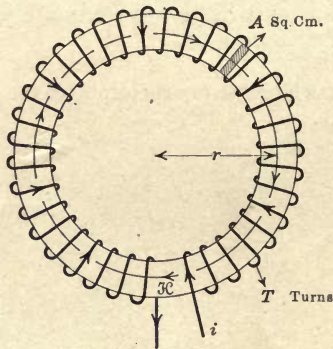

FIG. 40.—Closed solenoid.

The solenoid in Fig. 40 has T turns wound on a cardboard spool and is bent to form an annular ring. A current of i c.g.s. units flowing through these T turns produces a magnetic field of intensity H which field can therefore be represented by H lines of force.

If a unit pole n be moved once round the magnetic circuit through a distance of $2\pi r$ centimeters in a time of t seconds then, since the force on this pole due to the electromagnet is H dynes, the work done in moving the pole = $H \times 2\pi r$ ergs. But a unit pole has 4π lines of force, see page 3, and while this pole is moved once around the magnetic circuit these lines cut the T turns of the coil in a time of t seconds and generate in the coil an e.m.f. e , which in c.g.s. units = $4\pi T/t$, the number of lines cut per second. The coil therefore acts as a generator and supplies an amount of power = ei ergs per second so long as the unit pole is moving, that is for a time of t seconds. This power must be obtained at the expense of the power expended in keeping the unit pole moving so that

$$\begin{aligned} \mathcal{H} \times 2\pi r &= eil \text{ ergs} \\ &= (4\pi T/t)it \\ &= 4\pi Ti \end{aligned}$$

therefore $\mathcal{H} = 4\pi \frac{Ti}{L}$ where i is in c.g.s. units and $L = 2\pi r$

$$= \frac{4\pi}{10} \frac{TI}{L} \text{ where } I \text{ is in amperes.}$$

In a magnetic circuit such as that shown in Fig. 40 the field intensity \mathcal{H} is given by the formula

$$\mathcal{H} = \frac{4\pi}{10} \frac{TI}{L}$$

where I is the current in amperes

T is the number of turns of the solenoid

TI is called the ampere-turns

L is the length of the magnetic circuit in cm. = $2\pi r$ in the above case

\mathcal{H} is the field intensity in the magnetic circuit and is also the flux density or the number of lines of force per sq. cm. of solenoid cross section.

The total magnetic flux threading the magnetic circuit is

$$\begin{aligned} \phi &= \mathcal{H}A \\ &= \frac{4\pi}{10} \frac{TI}{L} A \end{aligned}$$

where A is the cross section of the solenoid in sq. cm.

40. Permeability.—If the solenoid is wound on a core of magnetic material such as iron or steel it is found that for the same number of exciting ampere-turns a much larger magnetic flux is produced and that

$$\mathcal{B}, \text{ the flux density} = \frac{4\pi}{10} \frac{TI}{L} \mu \text{ lines per sq. cm.}$$

$$\phi, \text{ the magnetic flux} = \frac{4\pi}{10} \frac{TI}{L} A \mu \text{ lines of magnetic flux.}$$

where μ is a quantity called the permeability of the material and is equal to unity for air and is greater than unity for magnetic materials such as iron and steel.

41. Reluctance of a Magnetic Circuit.—The above general law for the magnetic circuit may be expressed in slightly different form namely

$$\phi = \frac{4\pi}{10} TI \times \frac{A\mu}{L}$$

$$= \frac{m.m.f.}{\mathcal{R}}$$

or $m.m.f. = \phi \mathcal{R}$

where $m.m.f.$ called the magnetomotive force, is that which produces the magnetic flux and $= \frac{4\pi}{10} TI$ ampere-turns
 ϕ is the number of lines of magnetic flux in the magnetic circuit
 \mathcal{R} called the reluctance of the magnetic circuit $= \frac{1}{\mu} \frac{L}{A}$

From its similarity to the law for the electric circuit, namely $e.m.f. = IR$, the above law is sometimes called Ohm's law for the magnetic circuit.

Since the permeability of iron is much greater than that of air, the reluctance of an iron path is much lower than that of an air path of the same dimensions.

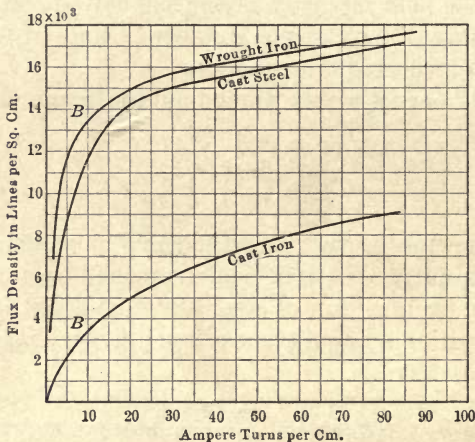

FIG. 41.—Magnetization curves.

42. Magnetization Curves.—The magnetic properties of iron and steel are generally shown by means of magnetization curves such as those in Fig. 41; the data from which these curves are plotted is determined in the following way.

Test pieces of iron are made in the form of an annular ring with a cross section of A sq. cm. and a mean length of magnetic path of L cm. These rings are then wound uniformly with T turns of wire as in Fig. 40 and the flux ϕ is measured for different values of the current I by means of special instruments.

The value of ϕ/A , the flux density, is then plotted against corresponding values of TI/L , the ampere-turns per unit length of magnetic path, as shown in Fig. 41, to give what is called the magnetization curve of the material.

The permeability $\mu = \frac{\phi/A}{TI/L} \times \frac{10}{4\pi}$ may then be determined.

When this value is plotted against flux density, as in Fig. 42, it may be seen that, once a particular density has been reached, the permeability decreases rapidly with increase of flux density.

Permeability curves are seldom used in practice, it is found to be more convenient to work with magnetization curves such as

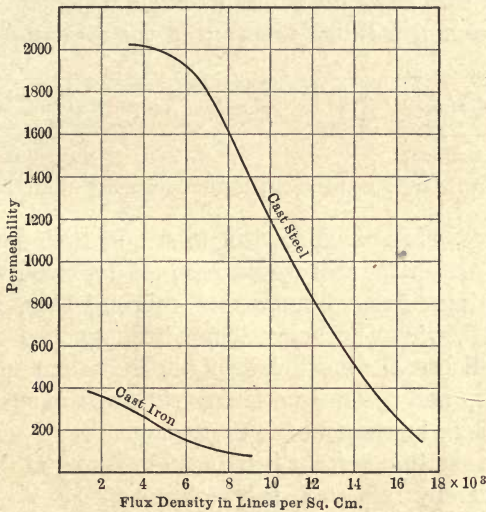

FIG. 42.—Permeability curves.

those shown in Fig. 41. An example of the use of such curves is given on page 44.

43. Residual Magnetism.—If, after a piece of iron has been magnetized by means of an exciting coil, the exciting current is reduced to zero, it will be found that the magnetism has not become zero but that some of it, called the residual magnetism, remains. If the iron is soft and annealed, this residual magnetism will be of negligible amount and the last traces of it may be made to disappear if the iron is subjected to vibration. If hard tool steel is used the residual magnetic field will be strong and the residual magnetism can be removed only with difficulty so that permanent magnets are generally made of this material.

44. Molecular Theory of Magnetism.—To account for the peculiar magnetic behavior of iron, Ewing suggested that molecules of iron are natural magnets each with its own north and south pole. When the iron does not exhibit magnetic properties then the molecular magnets are arranged in groups as shown in diagram A, Fig. 43, and their magnetic effects neutralize each other.

If the iron is placed in a strong magnetic field the molecular magnets will turn and point in the direction of the field as shown in diagram B, Fig. 43.

If a piece of iron is placed in an exciting coil, a small current in this coil will turn these molecular magnets which are not strongly held together and will line them up in the direction of the mag-

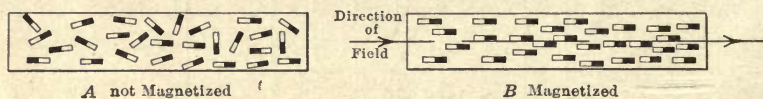

FIG. 43.—Arrangement of the molecules of an iron bar.

netizing force, these magnets will then add their own magnetic flux to that which the coil would produce if no iron were present. As the exciting current is increased, more of these magnets are lined up until, when the point B has been reached on the curve in Fig. 41 all but the most rigid of the molecular magnets have been lined up and the magnetic flux can then increase but little even for a large increase in the excitation.

When the exciting current is reduced to zero and the magnetizing force thereby removed, the molecular magnets reform into groups but, on account of molecular friction, they do not return quite to their original position but have a slight permanent displacement in the direction in which they have been magnetized and this accounts for the residual magnetism.

45. Hysteresis.—There is another phenomenon in connection with the magnetization of iron which can readily be explained by the molecular magnet theory, namely, that if the magnetism of a piece of iron is reversed rapidly the iron becomes hot. What is called hysteresis energy has to be expended in overcoming the molecular friction of the magnets and this appears in the form of heat.

CHAPTER VIII

SOLENOIDS AND ELECTROMAGNETS

46. Pull of Solenoids.—A solenoid is a conductor wound in the form of a helix. When an electric current is passed round a solenoid a magnetic field is produced, the direction of which may be determined by the corkscrew law, page 5. This field may be represented by lines of force as shown in diagram A, Fig. 44.

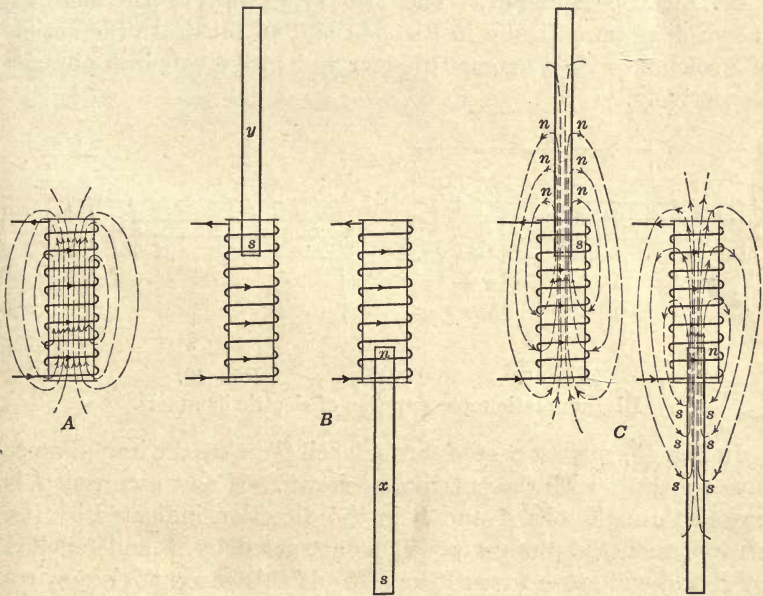

FIG. 44.—Action of a solenoid.

If long bar magnets are placed in the solenoid field as shown in diagram B, Fig. 44, then the *n* pole of magnet *x* will tend to move in the direction of the lines of force, see page 2, and be pulled into the solenoid, while the *s* pole of magnet *y* will tend to move in a direction opposite to that of the lines of force so that it also tends to move into the solenoid.

If the current in the solenoid is reversed, the magnetic field of the solenoid will reverse and the magnets *x* and *y* will be repelled.

If as in diagram C, Fig. 44, soft iron plungers are used instead of bar magnets, then the lines of force produced by the solenoid will pass through the plungers and cause magnetic poles to be induced; north poles will be formed where the lines of force leave the iron and south poles where they enter, see page 3. The induced polarity of the plungers shown in diagram C is the same as the polarity of the bar magnets in diagram B so that the plungers are pulled into the solenoid.

If the current in the solenoid is now reversed, the magnetic field of the solenoid will reverse but, since the induced polarity of the plungers will also reverse, the direction of the pull on the plungers will be unchanged.

47. Electric Hammer.—The two types of electric hammer shown diagrammatically in Figs. 45 and 46 illustrate the action of a solenoid with a magnet plunger and with a soft iron plunger respectively.

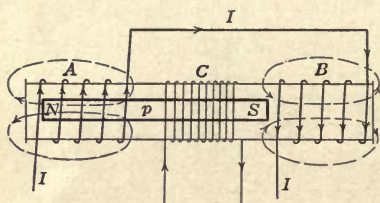

FIG. 45.

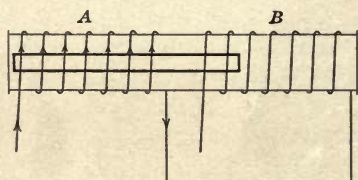

FIG. 46.

Diagrammatic representation of electric hammers.

In Fig. 45, current passed through coil *C* makes the iron plunger into a magnet with the polarity as shown. If now a current *I* is passed through coils *A* and *B* in the direction indicated by the arrows, then the plunger *p* will be attracted by *A* and repelled by *B* and will move toward the left. If this current *I* is now reversed, the plunger will move in the opposite direction, so that, by continually reversing the current that flows through *A* and *B*, the plunger *p* may be made to reciprocate.

Another type of hammer is shown in Fig. 46. The soft iron plunger is pulled into the position shown when coil *A* is excited, while if coil *B* is excited the plunger is pulled into this latter coil. By alternately exciting the two coils, the plunger may be made to reciprocate.

48. Variation of the Pull of a Solenoid.—When the plunger is in the position shown in A, Fig. 47, the reluctance of the magnetic

circuit is large since the path of the lines of flux is nearly all through air, so that the magnetic field and the plunger poles are both weak. As the plunger moves toward F , the reluctance of the magnetic circuit decreases because the amount of iron in the magnetic path is increasing, so that the magnetic field and the plunger poles become stronger.

With further motion of the plunger in the same direction, the reluctance of the magnetic circuit continues to decrease and the

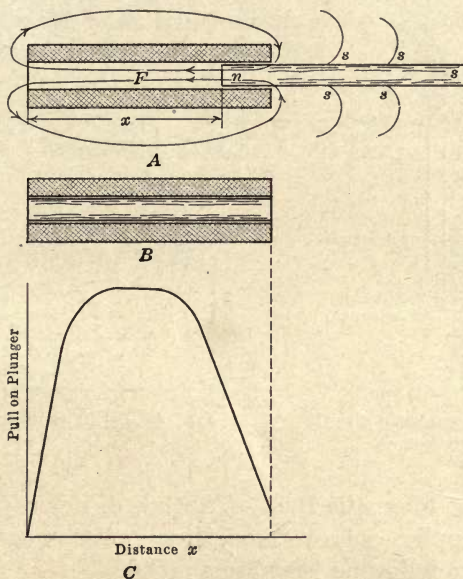

FIG. 47.—Pull of a solenoid.

strengths of the magnetic field and of the plunger poles to increase, but the induced south pole of the plunger now begins to come under the influence of the solenoid field and is repelled so that, although the north pole is still attracted, the resultant pull decreases and finally becomes zero when the plunger is in the position shown in diagram B; the reluctance of the magnetic circuit has then its minimum value.

The pull on the plunger varies with its position as shown in diagram C; over a considerable range the pull is constant.

49. Circuit Breaker.—The variation in the pull of a solenoid is taken advantage of in the type of circuit breaker shown diagrammatically in Fig. 48. Such a circuit breaker consists of the

switch C closed against the force of the spring S and held closed by the latch d . This latch is released by the plunger p which is lifted when the line current passing round the solenoid M reaches a predetermined value, the spring S then forces the switch open. If the plunger p is moved further into the solenoid by means of the adjusting screw a then the current required to lift this plunger will be decreased, by this means the circuit breaker can be adjusted to open with different currents.

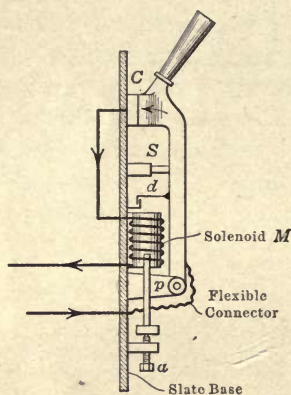

FIG. 48.—Automatic circuit breaker.

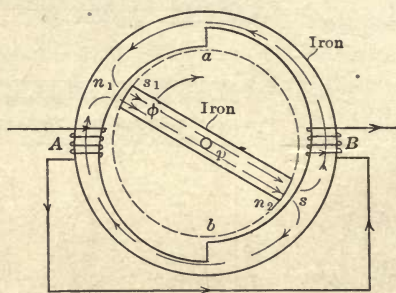

FIG. 49.—Electromagnetic motor.

50. Laws of Magnetic Pull.—The law of inverse squares, art. 2, page 1, applies only to imaginary point magnets; in practical work the following laws are applied.

The force on a piece of iron in a magnetic field in air tends to move the iron in such a direction as to reduce the reluctance of the magnetic circuit.

The magnitude of this force at any point is proportional to the space rate of change of the magnetic flux as the iron passes the given point.

An interesting application of this rule is shown diagrammatically in Fig. 49. The lines of force due to the coils A and B pass through the magnetic circuit as shown by the arrows and the pivoted piece of iron p tends to move until the reluctance of the magnetic path is a minimum, that is, until the air gaps between n and s have their minimum value and p is pointing in the direction ab . If the shape of the curved parts from a to b is such that the magnetic flux ϕ increases uniformly with the angle turned

through by p then the turning force, being proportional to the space rate of change of flux, will be constant over the whole range of motion.

The above principle is frequently used in toy electromagnetic motors, provision being made for cutting off the current in the exciting coils when p approaches close to the position ab and for switching the current on again when this point is passed.

51. Solenoids with Long and with Short Plungers.—When the plunger is of the same length as the solenoid, the pull becomes zero when the plunger is in the position shown in diagram B, Fig. 47, the position of minimum reluctance.

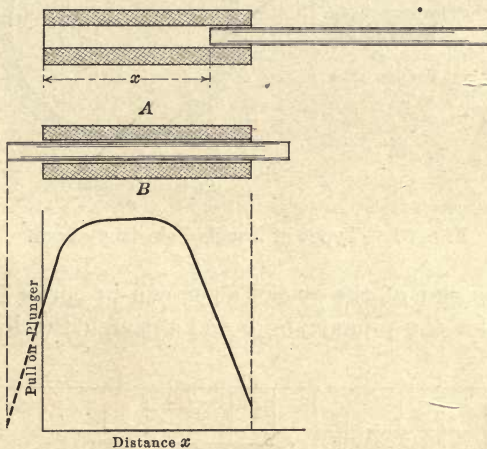

FIG. 50.—Pull of a solenoid.

When the plunger is longer than the solenoid, as is generally the case in practice, the reluctance does not become a minimum until the plunger projects equally from both ends as shown in diagram B, Fig. 50, so that the range of the solenoid is increased, as may be seen by a comparison between the curves in Fig. 47 and Fig. 50.

52. Ironclad Solenoids.—In order to reduce the reluctance of the return part of the magnetic circuit and at the same time to protect the windings, the ironclad construction shown in Fig. 51 is used. When the plunger is in the position shown in diagram A, the reluctance of the magnetic circuit is nearly all in the air path ab . As the plunger moves toward b , the flux increases and changes very rapidly toward the end of the stroke so that, while

the average pull is not much higher than that of the same solenoid with an air return path, a large pull over a short distance is ob-

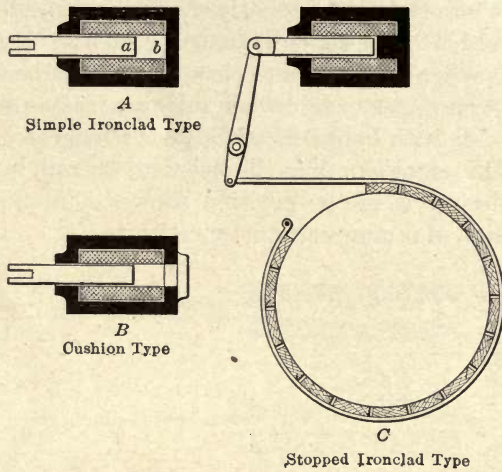

FIG. 51.—Types of ironclad electromagnet.

tained at the end of the stroke as shown in curve *B*, Fig. 52.¹ If a hole for the plunger be bored through the iron cover as

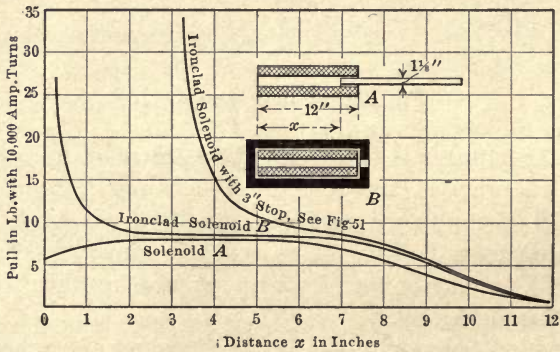

FIG. 52.—Pull of electromagnets.

shown in diagram *B*, Fig. 51, then there is no sudden jar at the end of the stroke but rather a cushion effect; the large increase of pull

¹Taken from an article by Underhill, *Electrical World and Engineer*, Vol. 45, p. 934 (1905.)

at the end of the stroke is lost however, although this is seldom a disadvantage.

Fig. 53 shows a series of test curves on ironclad magnets of the cushion type and will give the reader some idea of the magnitude and range of pull that can be obtained.

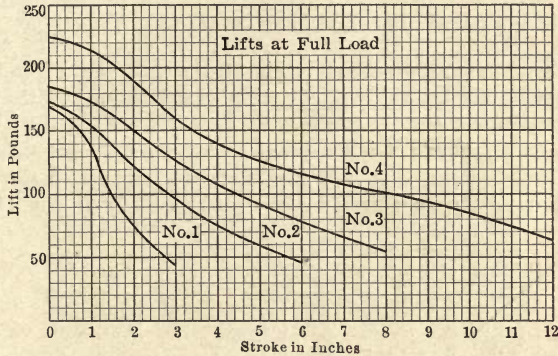

FIG. 53.—Pull of cushion type of electromagnet.

53. Lifting and holding magnets are generally of the horse-shoe or of the annular type shown diagrammatically in Figs. 54 and 55. As the iron to be lifted moves from *a* to *b*, Fig. 55, there

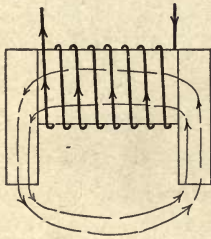

FIG. 54.—Horseshoe type of electromagnet.

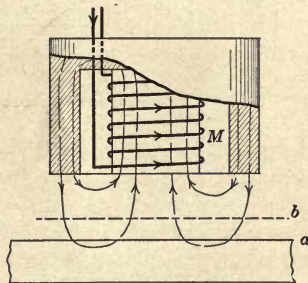

FIG. 55.—Annular type of electromagnet.

is little change in the flux threading the coil *M* and therefore only a small pull; when the iron approaches close to the poles of the magnet, however, the flux increases rapidly and the pull, being proportional to the space rate of change of flux, becomes large.

For such magnets the holding power may be determined very closely by Maxwell's formula

$$\text{pull in dynes} = \frac{\mathfrak{B}^2 A}{8\pi}$$

where \mathfrak{B} is the flux density across the contact surface in lines per sq. cm.

A is the total pole face area in sq. cm.

In the case of the magnet shown in Fig. 56, the scale on the iron to be lifted is assumed to be 0.05 cm. thick, it is required to determine how the pull varies with the exciting current.

To solve this problem it is necessary to assume different values for the total flux in the magnetic circuit then calculate the pull by the use of the above formula and the excitation by the use of the curves in Fig. 41, page 34.

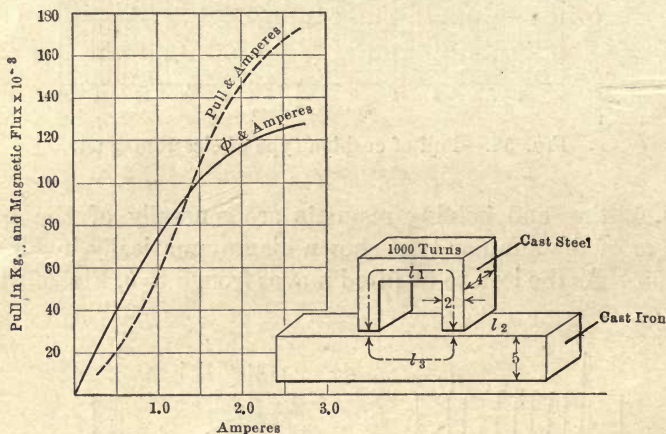

FIG. 56.—Pull of a horseshoe magnet.

l_1 , the length of the cast steel path = 20 cm.

l_2 , the length of each air gap = 0.05 cm.

l_3 , the length of the cast iron path = 12 cm.

A_1 , the cross section of the cast steel path = $2 \times 4 = 8$ sq. cm.

A_2 , the cross section of each air path = 8 sq. cm.

A_3 , the cross section of the cast iron path = $4 \times 5 = 20$ sq. cm.

If ϕ , the total flux = 80,000 lines

then \mathfrak{B}_1 , the flux density in the cast steel = 10,000 lines per sq. cm.

\mathfrak{B}_2 , the flux density in the air gaps = 10,000 lines per sq. cm.

\mathfrak{B}_3 , the flux density in the cast iron = 4,000 lines per sq. cm.

and the ampere turns per cm. for the cast steel = 7, see Fig. 41.

the ampere turns per cm. for the air gaps = $\frac{\mathfrak{B}_2 \times 10}{4\pi}$, see page 33.
= 8000

the ampere turns per cm. for the cast iron = 13, see Fig. 41
 and the total ampere turns = $7 \times 20 + 8000 \times 2 \times 0.05 + 13 \times 12$
 $= 140 + 800 + 156$
 $= 1096$

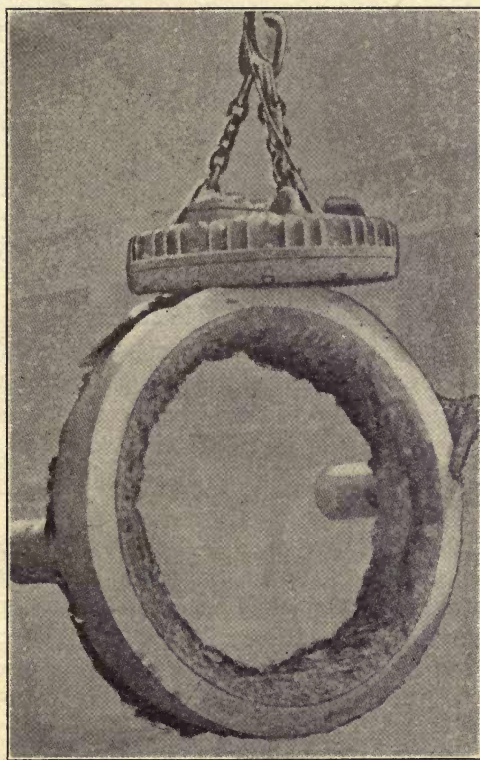
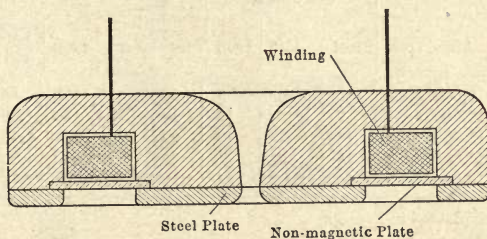

FIG. 57.—Annular type of electromagnet.

$$\begin{aligned} \text{the magnetic pull} &= \frac{(10,000)^2 \times 2 \times 8}{8\pi} \text{ dynes} \\ &= 64,000,000 \text{ dynes} \\ &= 65,000 \text{ gm.} \\ &= 65 \text{ kg.} \end{aligned}$$

Other values are worked out in the same way, the work generally being carried out in tabular form as below:

ϕ	Flux density			Ampere turns per centimeter			Total ampere turns				Amperes	Pull
	Steel	Air	Iron	Steel	Air	Iron	Steel	Air	Iron	Circuit		
64,000	8,000	8,000	3,200	5	6,400	9	100	640	108	848	0.848	42 kg.
80,000	10,000	10,000	4,000	7	8,000	13	140	800	156	1,096	1.096	65 kg.
96,000	12,000	12,000	4,800	11	9,600	19	222	960	228	1,408	1.408	94 kg.
112,000	14,000	14,000	5,600	19	11,200	25	380	1,120	300	1,800	1.800	126 kg.
128,000	16,000	16,000	6,400	55	12,800	34	1,100	1,280	408	2,788	2.788	164 kg.

These results are plotted in Fig. 56.

The possibilities of the annular type of magnet are illustrated in Fig. 57. A magnet which weighs 2250 lb. will lift skull cracker balls up to 12,000 lb., billets and slabs up to 20,000 lb. and miscellaneous scrap up to 500 lb. The power required to operate the magnet being 11 amp. at 220 volts or 2.42 kw.

54. Saturation of a Magnetic Circuit.—From the figures in the last problem, under the heading of total ampere turns, it may be noted that, when the flux densities in the steel and iron are low, most of the excitation is required for the air path or most of the reluctance of the magnetic circuit is in the air gap.

When the densities exceed 15,000 lines per sq. cm. for cast steel and 6000 for cast iron, the reluctance of the magnetic circuit increases rapidly and the curve showing the relation between flux and excitation, called the magnetization curve of the circuit, bends over rapidly as shown in Fig. 56, the circuit is then said to be nearly saturated.

55. Electromagnetic Brakes and Clutches.—One type of brake used on crane motors is shown in Fig. 58. The annular steel frame *A* of the electromagnet is fastened to the housing of the motor and carries the exciting coil *E*. The sliding disc *B* is fastened to the frame *A* of the magnet by means of a sliding key *F* and is free to move axially but cannot rotate.

When the motor is disconnected, the magnet is not excited and the springs *S* push the disc *B* into the ring *C* which is keyed to the motor shaft, the motor is thereby braked and brought rapidly to rest. When current is applied to start the motor, the coil *E* is excited at the same time and the disc *B* is attracted, releasing the ring *C*, so that the motor shaft is then free to rotate. Electromagnetic clutches are built on the same principle.

56. Magnetic Separator.—A useful application of the electromagnet is shown diagrammatically in Fig. 59. The magnetic

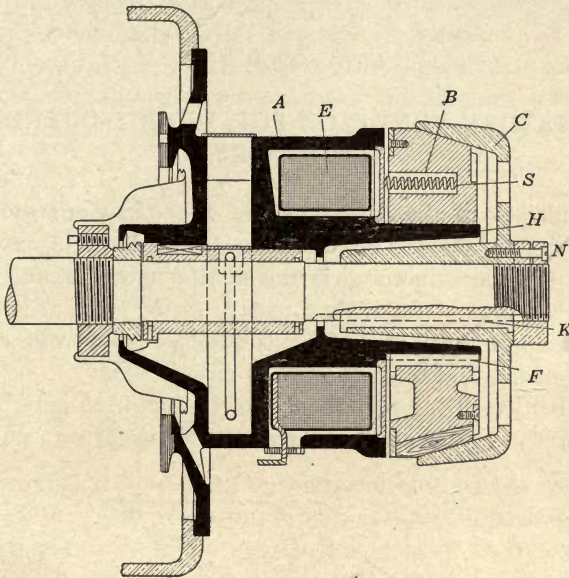

FIG. 58.—Electromagnetic brake.

pulley consists of an iron shell containing an exciting coil *C* which produces the magnetic field shown. Any iron particles carried over this pulley by the conveyer belt are attracted and are

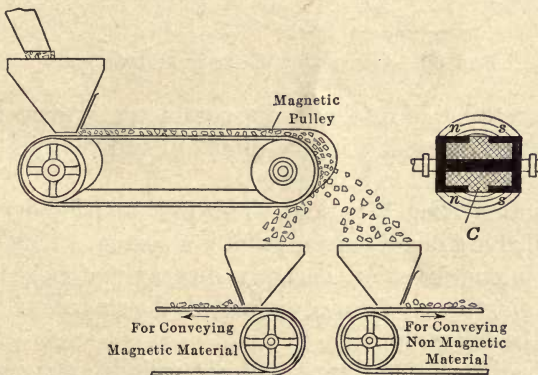

FIG. 59.—Magnetic separator.

therefore carried further round than the nonmagnetic materials with which they are mixed.

CHAPTER IX

ARMATURE WINDINGS FOR DIRECT-CURRENT MACHINERY

57. Principle of Operation of the Electric Generator.—The simplest type of electric generator is shown diagrammatically in Fig. 60. If the conductor ab is moved alternately up and down so as to cut the lines of force that pass from N to S , an e.m.f. will be generated or induced in the conductor which will cause an electric current to flow in the closed circuit $abcd$.

The direction of the current in the conductor ab may be determined by the right-hand rule, page 9. The current will reverse

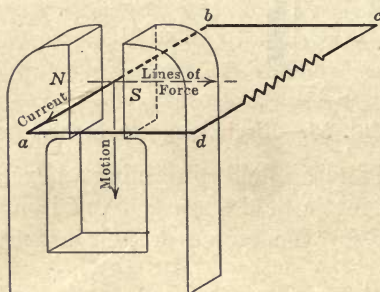

FIG. 60.—Generation of electromotive force.

when the direction of motion of the conductor is reversed, so that the current will flow first in one direction and then in the other; such a current is said to be alternating.

58. Gramme Ring Winding.—The first satisfactory machine that would give a direct current, that is a current which flows continuously in one direction, is shown diagrammatically in Fig. 61. Since this diagram is rather complicated, the stages in its development will be taken up.

The poles NS , Fig. 62, are bored out cylindrically and then, in order to reduce the reluctance of the magnetic circuit, a soft iron core is placed concentrically with the pole faces so as to make the air gap clearances a and b small. In these air gaps the conductors

c are moved in the direction of the arrow so as to pass down in front of the N pole and up in front of the S pole and thereby cut the lines of force that pass from N to S , so that e.m.f.s. are generated in these conductors, the direction of which, determined by the right hand rule, is shown in Fig. 62 at a particular instant.

The next step in the development of the machine is to attach the conductors c to the central core as shown in Fig. 63, so that

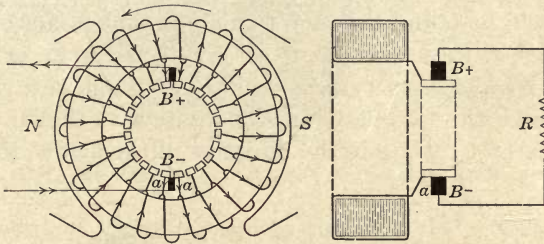

FIG. 61.—Gramme ring winding.

they are carried around when the core is driven by a prime mover; the lines of force still pass from N to S and do not rotate with the core. When this construction is used it is found necessary to laminate the core for the reason given in art. 62, page 55. The core area should be large enough to keep the flux density below the saturation point, see page 46, so that, while the centre of the

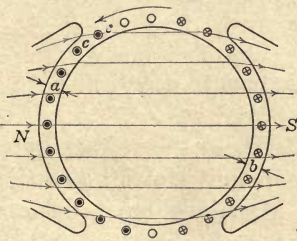

FIG. 62.

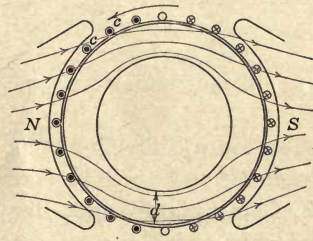

FIG. 63.

Stages in the development of the Gramme ring winding.

core may generally be cut out as shown so as to save material, the depth d must not be made too small.

It is now necessary to connect the individual conductors together so that their voltages add up and this is done by joining them as shown in Fig. 64 so as to form an endless helix. The complete core and winding form what is called the **armature** of the machine.

Since the lines of force pass through the iron core as shown rather than directly across the central air space from m to n , only the face conductors c cut these lines, no lines being cut by the inner conductors e . The direction of the e.m.f. in each conductor is indicated by crosses and dots in the usual way and it may be seen that no current can flow through this closed winding because the voltages in the conductors under the N pole are opposed by those in the conductors under the S pole. A difference of potential however will be found between f and g so that if stationary contacts placed at these two points are connected to an external circuit as in Fig. 65, then current will flow through this circuit and back through the two paths of the winding as shown. As long as the generator rotates in the direction of the arrow, the voltage

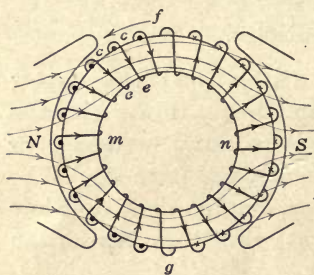

FIG. 64.

Stages in the development of the Gramme ring winding.

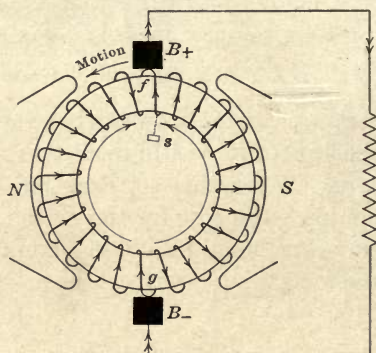

FIG. 65.

distribution will always be as indicated and the voltage between the points f and g will be constant in magnitude and direction.

59. Commutator and Brushes.—Machines have been constructed in which the stationary contacts B_- and B_+ , called the brushes, were allowed to rub directly on the winding as shown in Fig. 65, but the standard practice is to provide a special rubbing contact on each coil such as that shown dotted at s , Fig. 65. The complete winding supplied with these contacts is shown diagrammatically in Fig. 61 and is also shown in Fig. 66. These rubbing contacts form what is called the commutator, and the individual contacts are called the commutator segments.

In Fig. 61, current enters the machine at the negative brush B_- , passes through the commutator leads a to the winding

through which it passes to the positive brush B_+ and then on to the external circuit. The voltage between B_- and B_+ is maintained so long as the armature conductors cut lines of force, while

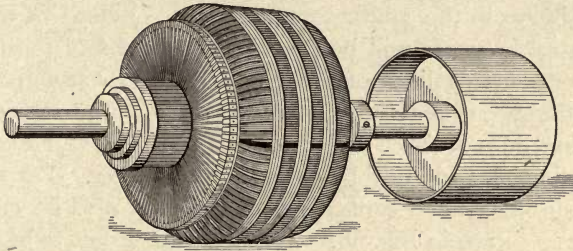
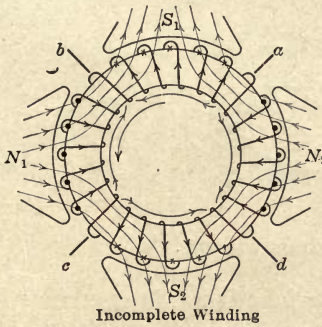

FIG. 66.—Armature with a Gramme ring winding.

the amount of current passing through the machine depends entirely on the resistance R of the external circuit.

60. Multipolar Windings.—It has been found economical in



Incomplete Winding

FIG. 67.

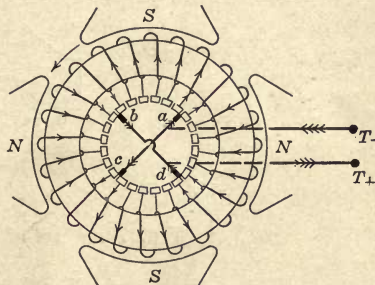

Complete Winding

FIG. 68.

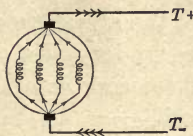

Diagrammatic Representation of a 4 Pole Winding

FIG. 69.

Gramme ring winding for a four pole machine.

practice to build machines with more than two poles, see page 56, the poles being arranged in pairs alternately N and S . In Fig. 68 the winding for a four-pole machine is shown diagrammat-

ically. The direction of the lines of force and of the e.m.f. in the conductors is shown in Fig. 67, from which diagram it may be seen that no current can flow in the closed winding because the voltages in the conductors under the N poles are opposed by equal voltages in the conductors under the S poles. A difference of potential however will be found between a and b due to the conductors cutting lines of force under pole S_1 and there is an equal difference of potential between a and d due to the conductors cutting lines of force under pole N_2 so that b and d are at the same potential and may be connected together. For the same reason the stationary contacts a and c may also be connected together as shown in Fig. 68. The external circuit to be supplied with current is connected between the terminals T_+ and T_- . This current will divide when it enters the machine and pass through the four paths in the winding as shown in Fig. 68 and also diagrammatically in Fig. 69.

61. Drum Windings.—One obvious objection to the ring winding is that only the outer conductors c , Fig. 63, cut lines of force,

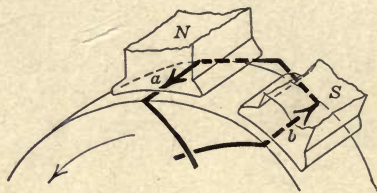

FIG. 70.—Coil of a drum winding.

the remainder of the winding being inactive. To overcome this objection most modern machines have what is called a drum winding made with coils which are shaped as shown in Fig. 70 and are placed on the surface of the armature core in such a way that the conductors a and b are under poles of opposite polarity. The e.m.fs. generated in these conductors therefore act in the same direction around the coil.

In Fig. 71, two four-pole machines are shown which are alike in every respect except that machine A has a ring coil between two adjacent commutator segments whereas machine B has a drum coil.

In Fig. 72, the same two machines are shown with quarter of the armature winding in place, the conductors being numbered in the order in which they are connected in series. By following

each winding from the negative to the positive brush, it will be found that in each case the e.m.f. between the brushes is due

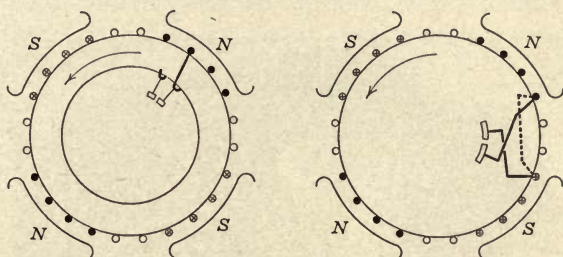

A. Gramme ring coil. B. Drum coil.
FIG. 71.—Comparison between ring and drum coils.

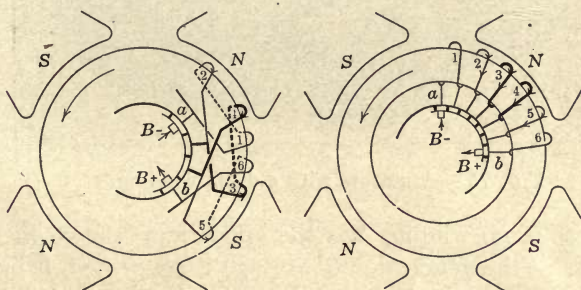

A. Gramme ring winding. B. Drum winding.
FIG. 72.—Comparison between ring and drum windings.

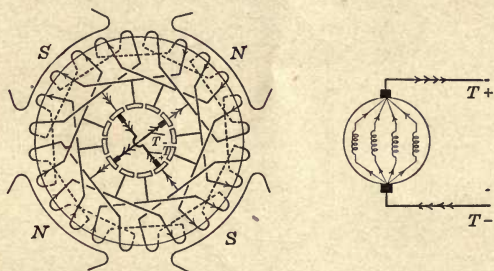

FIG. 73.—Complete winding. FIG. 74.—Diagrammatic representation.
Drum winding for a four pole machine.

to the voltage generated in four conductors in series, no voltage being generated in conductors 1 and 6 since they are not under the poles and so are not cutting lines of force.

Fig. 73 shows the complete drum winding, which has four paths between the negative and the positive terminals of the machine and may therefore be represented diagrammatically by Fig. 74.

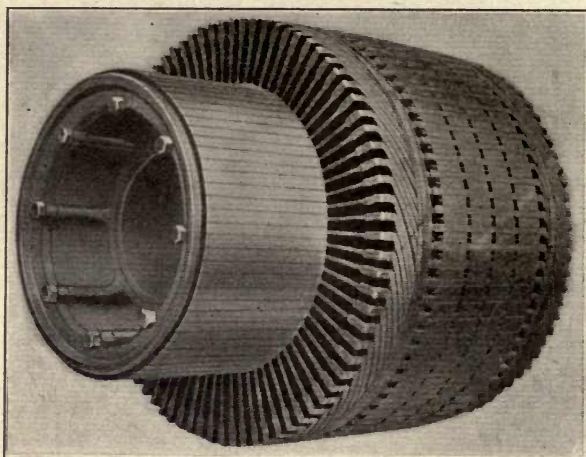

FIG. 75.—Armature with a drum winding.

A complete drum winding has the appearance shown in Fig. 75 but, so far as the generation of voltage is concerned, it produces the same result as the ring winding shown in Fig. 66. By choos-



FIG. 76.—Two turn coil for a drum winding.

ing a suitable strength of magnetic field, and a suitable number of conductors in series between negative and positive brushes, the designer is able to wind armatures for different voltages. The

coils shown in the diagrams in this chapter have only one turn between adjacent commutator segments but, in order that the voltages used in practice may be attained, it is generally necessary to make the coils as shown in Fig. 76 with several turns between segments.

62. Lamination of the Armature Core.—Fig. 77 shows an armature core on which may be placed either a ring or a drum winding. If this core is made of a solid block of iron, then, as it

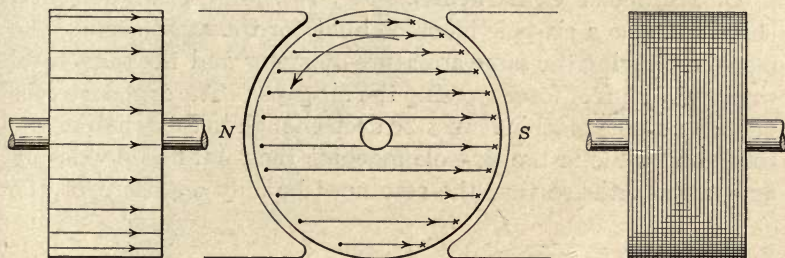

FIG. 77.—Eddy currents in a solid armature core. FIG. 78.—Laminated armature core.

rotates, e.m.fs. are induced in the surface layers and force current through the iron in the direction shown, which direction may be determined by the right-hand rule. These currents cannot be collected and utilized but power is required to maintain them.

To keep these eddy currents small, a high resistance is placed in their path by laminating the core as in Fig. 78, the laminations being separated from one another by varnish.

CHAPTER X

CONSTRUCTION AND EXCITATION OF DIRECT-CURRENT MACHINES

63. Multipolar Construction.—Fig. 79 shows a two-pole machine and also a six-pole machine built for the same output, the machines having the same armature diameter and the same total number of lines of force crossing the air gaps. The armature core of the two-pole machine must be deep enough to carry half of the total flux, while in the six-pole machine the total flux divides up among six paths so that the core need be only one-third of the

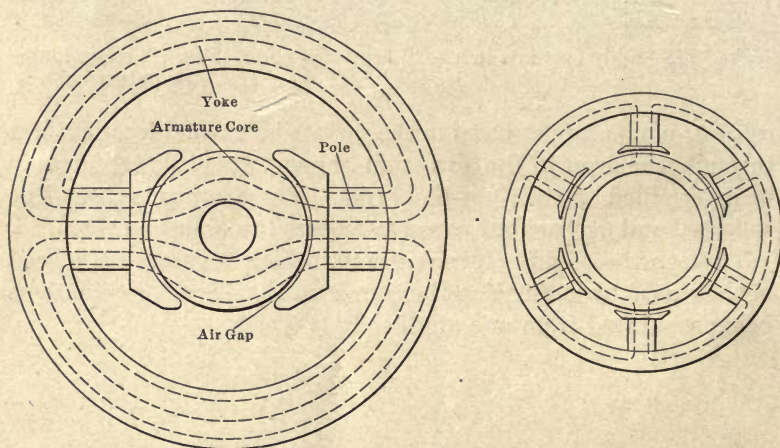

Two-pole machine.

Six-pole machine.

FIG. 79.—Machines with the same output.

depth of that of the two-pole machine. For the same reason the six-pole machine has the smaller cross section of yoke.

By the use of the multipolar construction therefore there is a considerable saving in material, but this is at the expense of an increase in the cost of labor because of the increased number of parts to be machined and handled. The number of poles is chosen by the designer to give the cheapest machine that will operate satisfactorily.

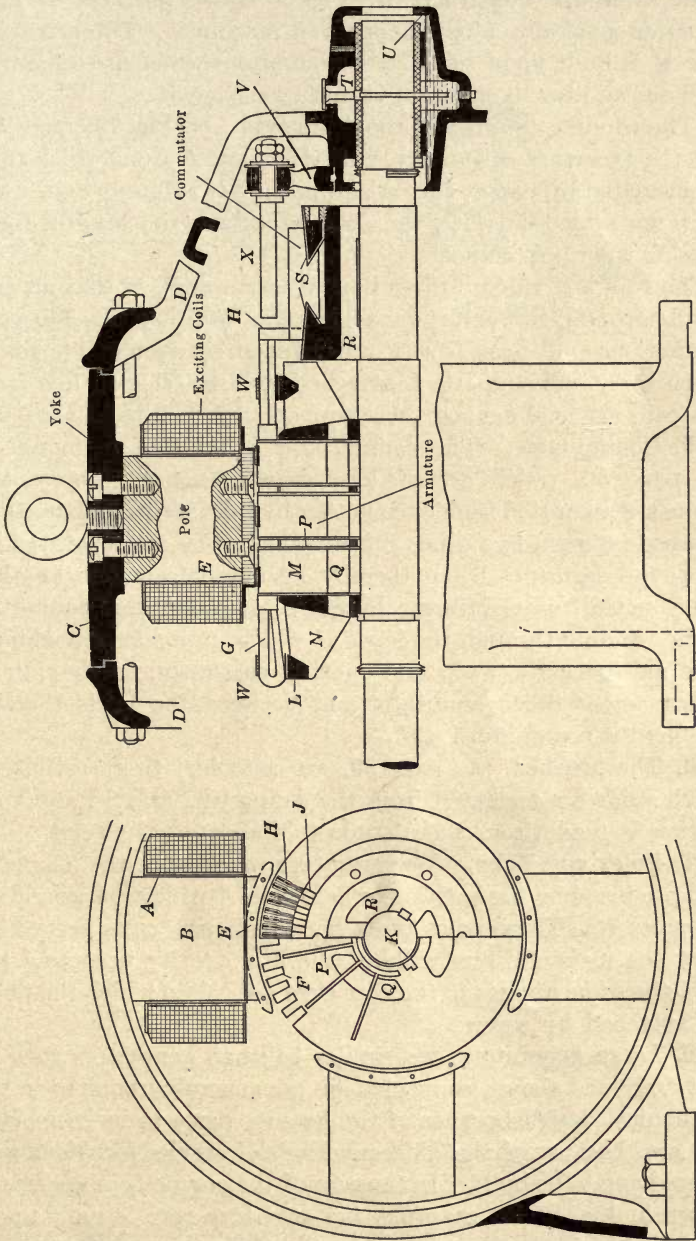

Fig. 80.—Small direct-current generator.

64. Armature Construction.—Fig. 80 shows the type of construction generally adopted for small machines. The armature core *M* is built up of sheet steel laminations which are separated from one another by layers of varnish; see page 55.

The winding shown is of the drum type, see Fig. 75, page 54, and the armature coils *G* are carried in slots *F* from which they are insulated by paper, cotton and mica. It is found that, even when embedded in slots, the conductors cut the lines of force crossing from pole to pole.

The core is divided into sections by spacers *P*, so that air can circulate freely through the machine and keep it cool. The core laminations and the spacers *P* are clamped between end heads *N* which carry coil supports *L* attached by arms shaped like fans. The coils are held against these supports by steel band wires *W*.

65. Commutator.—The commutator is built of segments *J*, see page 50, which are of hard-drawn copper. These segments are separated from one another by mica strips and are then clamped between two cones *S* from which they are separated by mica, the segments being thereby insulated from one another and from the frame of the machine. The segments are connected to the winding through the leads *H* which, in modern machines, have air spaces between one another as shown, so that air is drawn across the commutator and between the leads thereby keeping the commutator cool.

66. The brushes, see page 50, are attached to the studs *X*, which studs are insulated from the supporting arm *V*, and connection is made from these studs to the external circuit.

67. Poles and Yoke.—The armature revolves in the magnetic field produced by the exciting or field coils *A* which are wound on the poles *B*. These poles must have sufficient cross section to carry the magnetic flux without the flux density becoming too high, the same applies to the cast steel yoke *C* to which the poles are attached by screws.

68. Large generators are similar to small generators such as that described above; some changes are generally required in the mechanical design because of the heavier parts to be supported and also because of the different kinds of service for which machines have to be built. In the case of the engine type generator shown in Fig. 81 for example, the armature core is built up of segments instead of complete rings, while the commutator is

supported from the armature spider since the shaft is supplied by the engine builder.

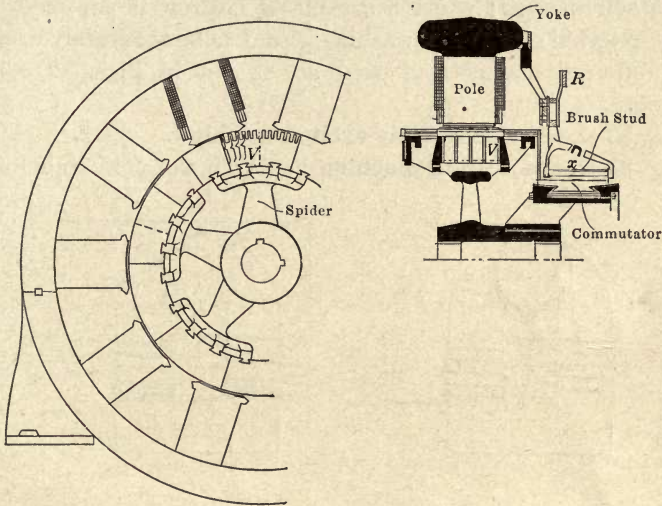

FIG. 81.—Large direct-current generator.

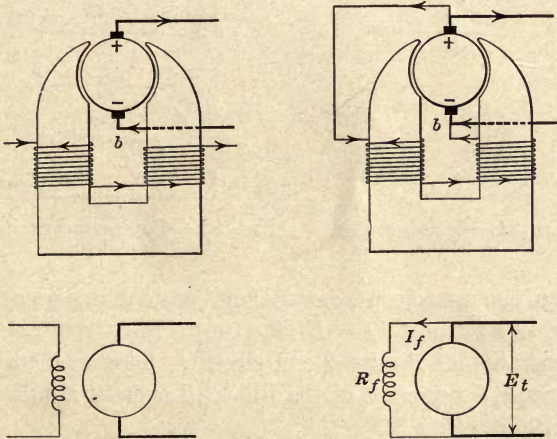

FIG. 82.—Separately excited machine.

FIG. 83.—Shunt excited machine.

69. Excitation.—Permanent magnets are used as field poles for small machines called magnetos; large machines are supplied

with electromagnets the excitation of which can readily be controlled.

When the generator itself supplies this exciting current it is said to be **self excited**; when the exciting current is supplied from some external source the machine is said to be **separately excited**. The different connections used are shown in Figs. 82, 83, 84 and 85.

Fig. 82 shows a **separately excited machine**.

Fig. 83 shows a **shunt machine** in which the field coils form a

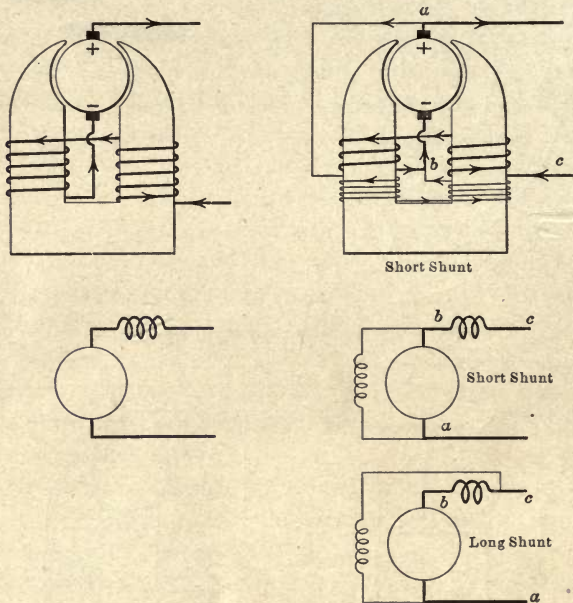

FIG. 84.—Series excited machine.

FIG. 85.—Compound excited machine.

shunt across the armature terminals and have many turns of small wire carrying a current $I_f = E_t/R_f$, the terminal voltage divided by the resistance of the field coil circuit. This exciting current seldom exceeds 5 per cent. of the full-load current supplied to the external circuit.

Fig. 84 shows a **series machine** in which the field coils are in series with the armature and have only about 5 per cent. of the number of turns that a shunt winding would have, but employ a larger size of wire because they have to carry the total current of the machine.

Fig. 85 shows a **compound machine** in which there are both shunt and series field coils. When the shunt coils are connected outside of the series coils the machine is said to have a long shunt connection; when connected inside of the series coils the connection is said to be short shunt.

CHAPTER XI

THEORY OF COMMUTATION

70. Commutation.—As the armature of a direct-current generator revolves, the direction of the current in each conductor changes while that conductor passes from one pole to that adjoining. In Fig. 86 for example, the direction of the current in the coil *M* is shown at three consecutive instants in diagrams *A*, *B* and *C*.

As the armature moves from *A* to *C* the brush changes from seg-

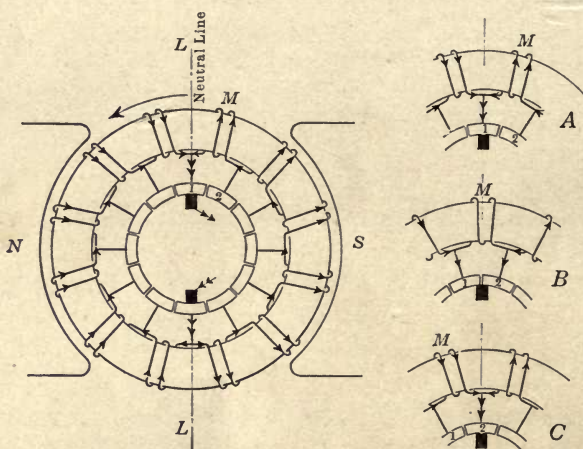

FIG. 86.—Diagram showing the reversal of the current in coil *M*.

ment 1 to segment 2 and the current in the coil *M* is automatically reversed. For a short period, as at *B*, the brush is in contact with both segments and, during this interval of time, the coil *M* is short circuited, but no e.m.f. is generated in the coil since it is not cutting lines of force, so that no current passes through the short circuit.

When in position *B*, the coil is said to be in the neutral position and the line *L* is called the neutral line.

The operation of reversing the current in an armature coil by

means of the brush and commutator segments is called commutation. Unfortunately the operation is not so simple as described above, because the coils have self induction and resist a change of current, and this we shall see causes sparking and gradual deterioration of the brushes and commutator. It is therefore necessary to make a detailed study of the subject because of its importance.

To study the variation of the current in the coil being commutated, the student should draw the brushes B_+ and B_- and also the poles N and S , Fig. 87, on a piece of heavy paper, and the armature and commutator on tracing paper. The armature should then be placed in the magnetic field and the direction of the current in a particular coil noted as the armature goes through one revolution. Such a model illustrates the operation much better than any set of diagrams such as those in Figs. 88, 89 and 90.

71. Theory of Commutation.—Fig. 88 shows part of a machine with a ring winding having two turns per coil and with the current in the coil M undergoing commutation. The brush B is made of copper so that the resistance of the contact between the brush and the commutator is negligible.

In diagram A, the currents I enter the brush through the commutator lead a .

In diagram B, the brush makes contact with two segments and the current flowing to the brush through the coils under the S pole no longer requires to flow round coil M because it has an easier path through the lead b , the current in coil M therefore dies down to zero because, being in the neutral position, the coil M is not cutting lines of force so that no e.m.f. is generated in it to maintain the current.

In diagram D, segment 1 of the commutator is about to break contact with the brush, and the coil M carrying no current is about to be thrown in series with the coils under the N pole. At the instant the contact is broken, as shown in diagram E, the current in coil M tries to increase suddenly from zero to a value I , but this change of current is opposed by the self induction of the coil M , so that the current prefers to pass to the brush across the air space x , causing sparking.

72. Shifting of the Brushes.—For sparkless commutation, it is necessary that the current in the coil M shall be reduced to zero and then, by some means or other, raised to a value I in the oppo-

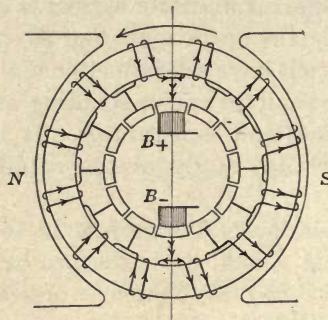

FIG. 87.

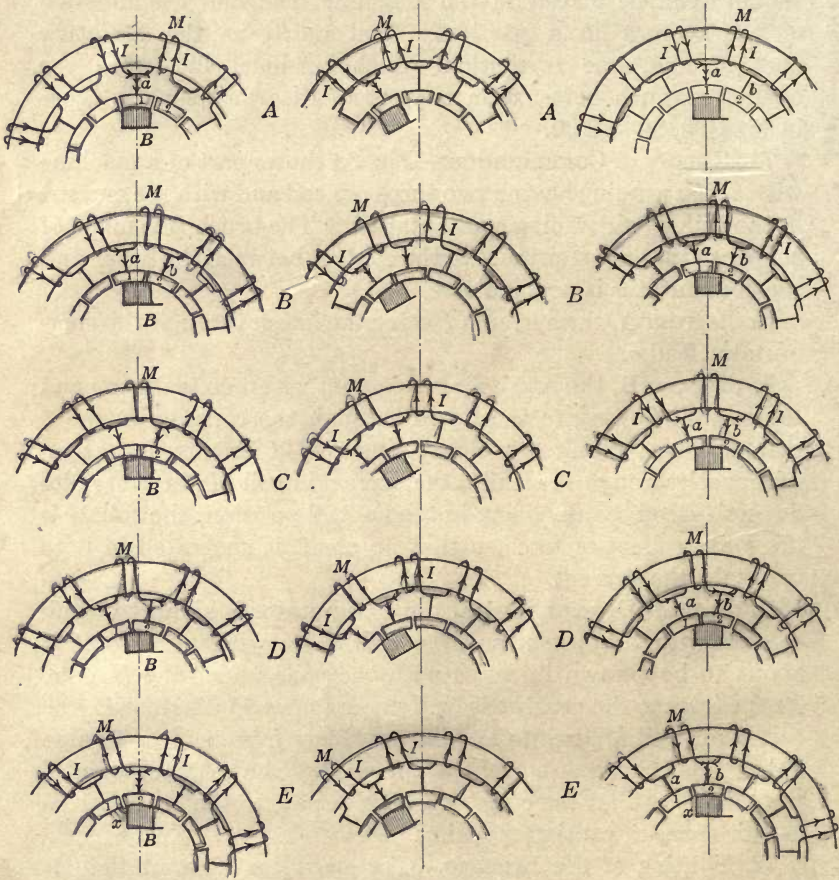

FIG. 88.

FIG. 89.

FIG. 90.

FIG. 88.—With low resistance brushes on neutral line.

FIG. 89.—With low resistance brushes shifted in the direction of motion.

FIG. 90.—With high resistance brushes.

Stages in the process of commutation.

site direction during the time the coil is short circuited by the brush, so that when the contact at x is broken, there shall be no sudden change of current in the coil.

This result may be obtained by shifting the brushes forward in the direction of motion as shown in Fig. 89 so that, while coil M is short circuited, it is in a magnetic field and an e.m.f. is generated in it which will produce the required growth of current. This magnetic field is called the reversing field. The corresponding diagrams in Figs. 88 and 89, and particularly diagrams D and E , should be carefully compared.

If the current taken from the generator is increased, the strength of the reversing field must also be increased if commutation is to be sparkless, so that the brushes must be moved nearer to the pole tips and further from the no-load position. The brush position must therefore be changed with change of load.

73. Interpole Machines.—It has been shown in the last paragraph that the commutation of a generator is improved if the

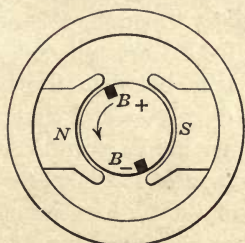

FIG. 91.

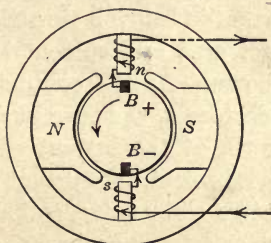

FIG. 92.

Diagrams illustrating the principle of the interpole generator.

brushes are shifted forward in the direction of motion of the machine so that the short circuited coils are in a reversing magnetic field, thus in Fig. 91 the brush B_+ is moved so as to come under the tip of the N pole and the brush B_- is moved so as to come under the tip of the S pole. The same result may be accomplished by leaving the brushes in the neutral position and bringing an auxiliary n pole over the brush B_+ and an auxiliary s pole over the brush B_- , as shown in Fig. 92. These auxiliary poles are called interpoles and a machine so equipped is called an interpole machine.

It is desirable that the strength of the reversing field increase with the current drawn from the armature and to obtain this

result the interpoles are supplied with series field coils as shown in Fig. 92.

74. Carbon brushes have a contact resistance which is generally about ten times that of copper brushes. The effect of this high contact resistance is to improve commutation, as may be seen by a comparison between Figs. 88 and 90.

In diagram B, Fig. 90, the brush makes contact with segment 2 and some of the current I that was flowing round coil M now flows directly to the brush through lead b . Since however the contact with segment 2 is small in area, the current i_b flowing through this contact is small and some of the current I continues to flow around coil M .

As the armature rotates and the contact area between the brush and segment 2 increases, the current i_b increases and that in coil M decreases until, at the instant shown in diagram C, the current in this coil has become zero.

In diagram D, the contact area between the brush and segment 1 is small while that between segment 2 and the brush is large so that the current in lead a is throttled by the high resistance of the small contact area and current is forced around coil M in the direction shown. As the contact area between the brush and segment 1 decreases, the current i_a decreases and that in coil M increases until, at the instant shown in diagram E, when the contact at x is broken, the current in coil M has been raised to the value I by this slide valve action of the high resistance brush. The contact can then be broken without causing any sudden change of current in the coil M and therefore without sparking.

In the above theory, the action at the positive brush has been considered; the action at the negative brush is similar and need not be considered separately. The theory applies to a drum winding as well as to a ring winding, the only difference between the two cases being in the shape of the coil, see Fig. 71.

By the use of carbon brushes it is possible to operate generators from no-load to full-load without shifting of the brushes during operation, and for that reason carbon brushes have superseded copper brushes on modern machines.

CHAPTER XII

ARMATURE REACTION

75. The Cross-magnetizing Effect—In Fig. 93, diagram A shows the distribution of the magnetic flux in a two-pole machine when the field coils are excited and no current is flowing in the armature winding; the flux density is uniform under the pole face so that the same number of lines of force cross each square centimeter of the air gap between the pole face and the armature surface.

Diagram B shows the distribution of magnetic flux when the armature is carrying current, the brushes being in the neutral

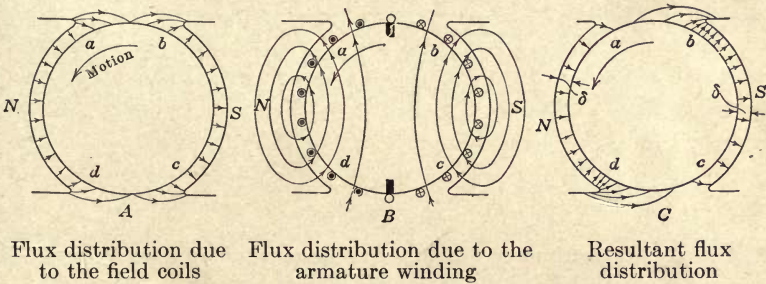

FIG. 93.—Armature reaction with the brushes in the neutral position.

position and the field coils not excited. The current passing downward in the conductors under the S pole of the machine and up in those which are under the N pole causes the armature to become an electromagnet with lines of force which pass through the armature in a direction determined by the corkscrew law, see page 5, and which return across the pole faces to complete the circuit.

Diagram C shows the resultant distribution of magnetic flux when, as under load conditions, the armature is carrying current and the field coils are excited; C is obtained by combining the magnetic fields of A and B. Under pole tips a and c the magnetic field due to the current in the armature is opposite

in direction to that due to the current in the field coils while under tips *b* and *d* the two magnetic fields are in the same direction.

Since the armature magnetic field is at right angles to that produced by the field magnets, the effect produced is called the cross-magnetizing effect of armature reaction.

76. The Demagnetizing Effect.—In a direct-current generator the brushes are shifted from the no-load neutral in the direction of motion so as to improve commutation, see page 63, the distribution of the magnetic flux when the armature is carrying current and the field coils are not excited will then be as shown in diagram A, Fig. 94. The armature field is no longer at right angles to that produced by the field magnets but acts in the direction *oz*, it may however be considered as the resultant of two magnetic fields, one in the direction *oy*, called the cross-magnetizing component and the other in the direction *ox*, called the demagnetizing component because it is directly opposed to the field produced by the field magnets. Diagram B, Fig. 94, shows the armature divided

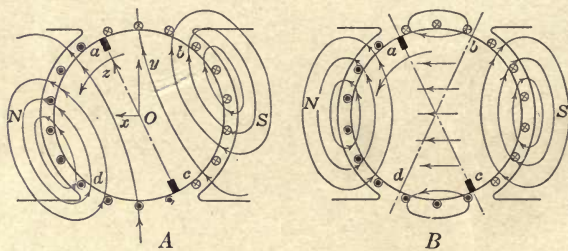

FIG. 94.—Flux distribution due to the armature winding when the brushes are shifted in the direction of motion.

so as to produce these two components; the belts of conductors *ab* and *cd*, when carrying current, tend to demagnetize the machine, while the belts *ad* and *bc* are cross-magnetizing in effect.

77. Effect of Armature Reaction on Commutation.—When interpoles are not supplied, the brushes are shifted forward in the direction of motion so that commutation takes place in a reversing magnetic field under pole tips *a* and *c*, Fig. 93. But it may be seen from diagram C, Fig. 93, that the effect of armature reaction is to weaken the magnetic field under these pole tips and so impair the commutation.

This effect must be minimized by making the air gap clearances δ as large as possible so that there is a large reluctance in the path of the cross field. Increasing the air gap also increases

the reluctance of the main magnetic path and, in order to produce the required main flux, it is then necessary to increase the number of exciting ampere turns on the poles. The machine is then said to have a stiff magnetic field because it is not greatly affected by armature reaction.

CHAPTER XIII

CHARACTERISTICS OF DIRECT-CURRENT GENERATORS

78. Magnetization or No-load Saturation Curve.—The voltage generated in the armature of a direct-current machine, being proportional to the rate of cutting lines of force, is proportional to the speed and to the flux per pole or

$$E = a \text{ const.} \times \phi \times \text{r.p.m. for a given machine.}$$

The flux per pole, and therefore the voltage, increase with the excitation, and the curve showing the relation between no-load voltage and excitation, the speed being constant, is called the magnetization or the no-load saturation curve of the machine. Such

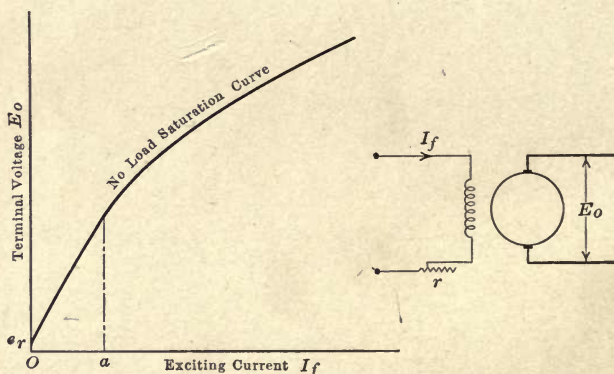

FIG. 95.—Magnetization curve of a direct current generator.

a curve is shown in Fig. 95. With no excitation there is a voltage e_r due to residual magnetism; as the exciting current is increased, the flux per pole and the voltage increase in the same ratio until, with an exciting current of oa amperes the magnetic circuit begins to saturate and the voltage to increase more slowly.

To obtain such a curve experimentally, the generator is driven at a constant speed with no connected load. The field coils are separately excited as shown in Fig. 95 and the exciting current is increased by gradually cutting out the resistance r .

Simultaneous readings of the voltage E_o and the current I_f are taken and the results plotted as shown.

79. Self excitation is made possible by virtue of the residual magnetism in the magnetic circuit of the machine. If for example a shunt generator, connected as in Fig. 96, is rotating, a small voltage e_r is generated in the armature even with no exciting current in the field coils, because the lines of force of residual magnetism are being cut. This small voltage sends a small current through the field coils, which increases the magnetic flux and causes the generated voltage to increase, and this in turn further increases the excitation, and so the voltage of the machine builds up.

The voltage and the exciting current cannot build up indefinitely because, as the exciting current increases, the magnetic

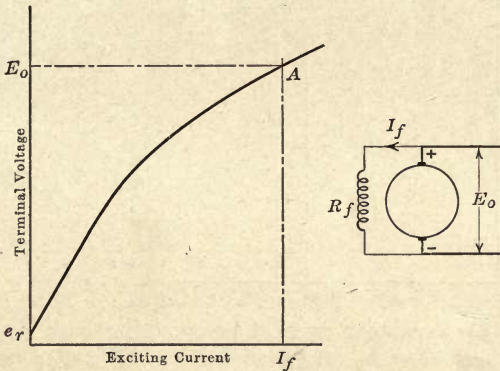

Fig. 96—Magnetization curve of a shunt generator.

circuit becomes more nearly saturated and the voltage increases by a smaller and smaller amount until finally, when the point A is reached at which $E_o/I_f = R_f$, the voltage and exciting current can increase no further.

It frequently happens that, when a generator is started up for the first time, the e.m.f. generated in the armature due to residual magnetism sends a current through the field coils in such a direction as to oppose the residual flux, and the voltage, instead of building up, is reduced to zero. In such a case it is necessary to reverse the connections of the field coils so as to pass current through them in the opposite direction.

80. Regulation Curve of a Separately Excited or of a Magneto Generator.—This curve, sometimes called the external character-

istic, gives the relation between E_t , the terminal voltage, and I_a , the line current, and is shown in Fig. 97 for the case of a separately excited machine operating at constant speed and with constant excitation. The terminal voltage drops as the current taken from the machine is increased because:

a. The flux per pole is reduced by armature reaction, see page 68, so that E_g , the e.m.f. generated by cutting this flux, is also reduced.

b. The terminal voltage E_t is less than the generated voltage E_g by the armature resistance drop $I_a R_a$, that part of the generated voltage required to force the armature current through the resistance of the armature winding and of the brush contacts.

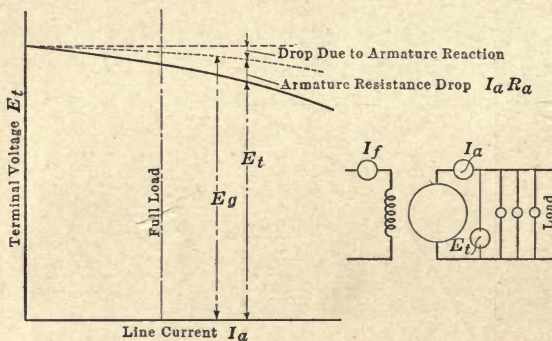

Fig. 97.—Regulation curve of a separately excited generator.

To obtain such a curve experimentally, the generator is loaded on a bank of lamps, or some other suitable load that can readily be adjusted, as shown in Fig. 97. The speed and the exciting current I_f are kept constant, while the current taken from the machine is gradually increased by connecting an increasing number of lamps in parallel across the terminals, that is by providing more paths through which current can pass. Simultaneous readings of the voltage E_t and of the current I_a are taken and the results plotted as in Fig. 97.

The regulation of the above generator is defined as the per cent. change in voltage when full-load is thrown off the machine, the speed and the field circuit being unchanged. The regulation therefore $= (E_o - E_t)/E_t$.

81. Regulation Curve of a Shunt Generator.—This curve is shown in Fig. 98 for a constant speed shunt excited generator.

The terminal voltage drops as the current taken from the machine is increased because:

- a. The flux per pole is reduced by armature reaction.
- b. The armature drop $I_a R_a$ is used up in the machine itself.
- c. The exciting current I_f is equal to E_t/R_f , where R_f is the constant resistance of the shunt field circuit, so that as the terminal voltage drops the exciting current decreases and causes the voltage to drop still further. Because of this third effect the terminal voltage of a generator with a given load will be lower when the machine is shunt excited than when separately excited.

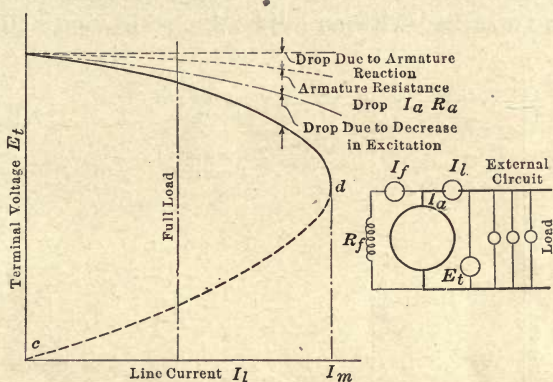

FIG. 98.—Regulation curve of a shunt generator.

To obtain such a curve experimentally the machine is connected up as shown. The speed and the resistance of the shunt circuit are kept constant while the current taken from the machine is gradually increased, and simultaneous readings are taken of the voltage E_t and the current I_l , these results are plotted as in Fig. 98.

As the resistance of the external circuit is decreased, the current supplied by the machine increases and the terminal voltage drops until point d is reached. A further reduction in the external resistance allows an increased current to flow for an instant, but this increase of current reacts by armature reaction and causes such a large drop in voltage and in exciting current that the armature current cannot be maintained. In the extreme case when the generator is short circuited, that is, the terminals of the machine are connected through a circuit of negligible resistance, then the terminal voltage must be zero and there can be no field excita-

tion, so that no current can flow in the short circuit; thus c , Fig. 98, is a point on the load curve.

If a shunt generator is short circuited, it carries the maximum current I_m for only a short interval of time before it loses its voltage and is thereby protected from injury. For the same reason a shunt generator will not build up if a very low resistance is connected across its terminals. Because of this self protecting power, shunt generators are used with advantage for electric furnace and other work during the process of which the machine is liable to be short circuited.

82. To maintain the terminal voltage constant, shunt generators are operated with an adjustable resistance, called a field

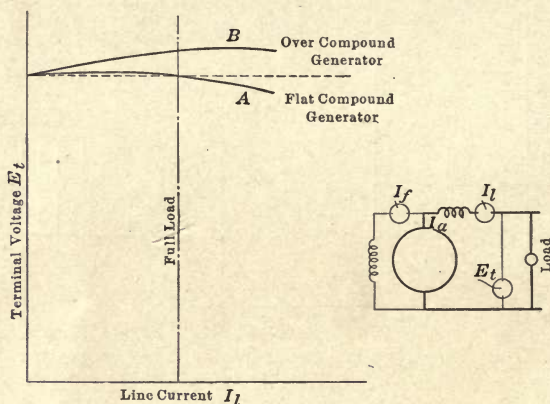

FIG. 99.—Regulation curves of compound generators.

rheostat, placed in the field coil circuit. As the load on the machine increases and the voltage drops, some of this resistance may be cut out either automatically or by hand so as to increase the excitation. Automatic regulators for this purpose are used with alternating-current generators, see page 249, but are seldom used with direct-current generators because the same result may be obtained more cheaply by the use of compound windings.

83. Compound generators, operated without a regulator, maintain the terminal voltage approximately constant from no-load to full-load, because the line current passes through the series field coils and causes the total excitation to increase with the load. By the use of a large number of series turns, the total excitation may increase so much with the load that the terminal voltage will rise, as shown in curve B Fig. 99, the machine is then

said to be overcompounded. When the terminal voltage has the same value at full-load as at no-load, the machine is said to be flat compounded.

Generators for lighting and power service are generally flat-compound machines wound for 125 or for 250 volts. For railway service the generators are overcompounded so as to maintain the trolley voltage at some distance from the power house. Street railway generators are invariably wound for 600 volts at full-load, while for interurban and trunk line work 2400 volts has been used.

84. The Regulation Curve of a Series Generator.—Curve A, Fig. 100, shows what the relation between voltage and current

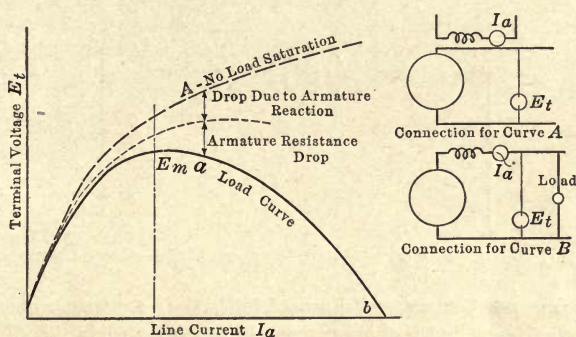

FIG. 100.—Regulation curve of a series generator.

in a series generator would be if armature resistance and armature reaction were negligible; the voltage would increase with the load current since this is also the exciting current. Curve A is really the no-load saturation curve of the machine and is determined by separately exciting the field coils, as shown in diagram A, so that no current flows in the armature. Curve B shows the actual relation between terminal voltage and load current; the drop of voltage between curves A and B consists of the portion due to the reduction in the flux per pole caused by armature reaction, and $I_a R_a$ the drop of voltage in the armature winding, brush contacts and series field coils.

Series generators were formerly used as constant-current generators for the operation of arc lamps in series. They were operated with automatic regulators so as to have the line ab , Fig. 100, nearly vertical, and the current practically constant for all voltages up to E_m .

A very simple type of regulator for this purpose is shown diagrammatically in Fig. 101, where C is a carbon pile rheostat and B is a solenoid carrying the line current. If the current in the external circuit increases, the pull of the solenoid B also increases and the carbon pile is compressed and its resistance thereby decreased, see page 29, so that it shunts more of the current from the series field coils. The flux in the machine is therefore reduced, and the voltage drops until the current in the line reaches the value for which the pull of the solenoid was adjusted.

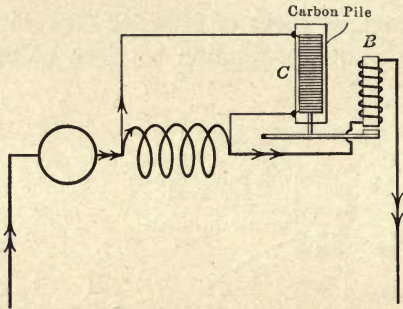

FIG. 101.—Automatic regulator for a constant-current generator.

85. Problem on Generator Characteristics.—*a.* A direct-current shunt generator was tested with the brushes shifted forward in the direction of motion. The voltage drop between no-load and full-load was 6 volts, what are the causes of this drop in voltage?

b. If the brushes had been placed on the neutral position, why would the voltage drop have been different and what would you expect its value to be. Why are the brushes not placed on the neutral position in non-interpole machines?

c. Series field coils were added to the machine and the voltage dropped 20 volts from no-load to full-load, what was the cause of this excessive drop?

d. After the series field coil circuit has been fixed, the voltage was found to increase by 6 volts from no-load to full-load while flat compounding was desired, what changes would you suggest should now be made?

a. The voltage drop is due to:

1. The reduction in the flux per pole due to the demagnetizing effect of armature reaction, since the brushes are shifted forward.

2. The armature resistance drop.

3. The reduction in the exciting current which causes the flux per pole to decrease and the voltage to drop still further, see page 73.

b. When the brushes are placed in the neutral position, the armature reaction has no demagnetizing effect, see page 68, so that the voltage drop will be less than when the brushes are shifted forward, and will probably not exceed 4 volts.

Machines have the brushes shifted forward in order to improve commutation and, unless interpoles are supplied, these machines will generally spark at the commutator on full-load if the brushes are kept on the no-load neutral.

c. Since the voltage drop when the series field was added was greater than before, it is evident that this field has been connected backward so as to oppose the shunt field instead of assist it, the series connections must therefore be reversed so that the current passes through the series coils in the proper direction.

d. Since the compounding effect of the series coils is too large, it will be necessary to reduce the number of series turns or to reduce the current flowing through these turns. The latter method is that generally adopted, a shunt being placed in parallel with the series coils, as shown in Fig. 102, so that, of the total current I_t , only a fixed portion passes through the series field coils.

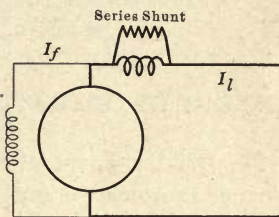

FIG. 102.—Series shunt to vary the series excitation.

CHAPTER XIV

THEORY OF OPERATION OF DIRECT-CURRENT MOTORS

86. Driving Force of a Motor.—An electric generator and an electric motor are identical in structure. The generator is used to transform mechanical energy into electrical energy, while the same machine operating as a motor can be used to transform electrical energy into mechanical energy.

If a voltage is applied at the terminals of the machine in diagram B, Fig. 103, so as to send current through the armature conductors in the direction shown, then, since these conductors are carrying current and are in a magnetic field, they are acted on by forces all of which act in the same direction around the shaft and so cause the armature to rotate.

87. Driving and Retarding Forces in Generators and Motors.—The generator in diagram A, Fig. 103, driven by an engine in the

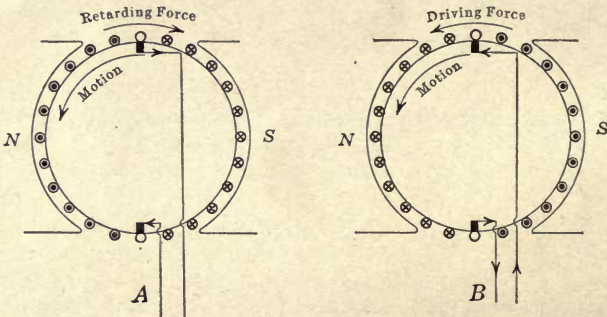

FIG. 103.—Driving and retarding forces in a generator and in a motor.

direction shown, supplies electric power to a circuit, and current flows through the armature conductors in the direction indicated by the crosses and dots. There is a force exerted on these conductors in as much as they are carrying current in a magnetic field, which force is opposed to the direction of motion, see page 13, and the larger the current the greater is this retarding force. To keep the generator running, the driving force of the engine must

be great enough to overcome this retarding force and also to overcome the friction force of the machine.

The same machine operating as a motor is shown in diagram B. A voltage applied at the motor terminals from some external source forces current through the armature conductors in the direction shown and, since these conductors are carrying current in a magnetic field, they are acted on by forces which cause the armature to rotate in a direction that may be determined by the left-hand rule, page 7. Now the conductors, rotating with the armature, cut lines of force, and an e.m.f. is generated in the winding in exactly the same way as if the machine was driven by an engine. This e.m.f. acts in the same direction as in diagram A since the machines have the same polarity and rotate in the same direction. This generated e.m.f. is therefore opposed to the current in the conductors and opposed to the applied e.m.f., for which reason it is called the back or counter e.m.f. of the motor.

In the case of both a generator and a motor, there is a force acting on the conductors of the armature in as much as they are carrying current and are in a magnetic field. This is the driving force in the case of a motor and the retarding force in the case of a generator. There is also an e.m.f. generated in the armature of each machine in as much as it is rotating in a magnetic field. This e.m.f. acts in the direction of the current flow in the case of a generator but opposes the current flow in the case of a motor.

In order that current may flow through a motor armature, the applied e.m.f. E_a must be greater than the back e.m.f. E_b and

$$E_a = E_b + I_a R_a$$

where E_a is the applied voltage

E_b is the back e.m.f.

$I_a R_a$ is the voltage required to force the armature current I_a through the armature resistance R_a and is called the armature resistance drop.

In the above equation it is most important to note that, of the applied voltage E_a , the part which forces the current through the resistance of the armature is $I_a R_a$ and seldom exceeds 5 per cent. of E_a ; the remaining part of the applied voltage is required to overcome E_b , the back generated voltage of the machine.

88. The Back E.M.F.—The existence of the back e.m.f. may readily be shown by experiment. If for example a motor, con-

nected as shown in Fig. 104, is driving a flywheel, and the switch S is suddenly opened so as to disconnect the armature from the power mains, the flywheel will keep the machine running, but the ammeter reading will become zero and the voltmeter reading will drop suddenly from E_a to E_b , the voltage generated by the rotating armature, and will then drop slowly to zero as the motor comes to rest.

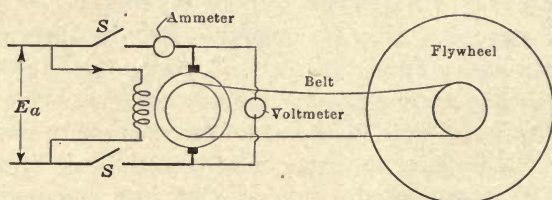

FIG. 104.—Experimental determination of the back e.m.f.

Example: Let E_a , the applied voltage, be 110, I_a the armature current, 100 amp., and R_a the armature resistance, 0.04 ohms. The voltmeter reading will be 110 volts while switch S is closed but will drop suddenly to $110 - (100 \times 0.04) = 106$ volts at the instant the switch is opened, and will then drop slowly to zero as the motor slows down.

89. Theory of Motor Operation.—The power taken by a motor from the mains changes automatically to suit the mechanical load. Consider the case of a motor connected as shown in Fig. 105, the applied voltage, the exciting current I_f , and the magnetic flux per pole being constant. If the motor is at standstill and the switch S is closed, a large current $I_a = E_a/R_a$ will flow through the armature, the back voltage E_b being zero since the armature conductors are not cutting lines of force. The armature conductors carrying current, being in a magnetic field, are acted on by forces which overcome the resisting forces of friction and of the load and cause the motor to rotate. As the motor increases in speed, the back e.m.f. E_b also increases since it is proportional to the rate at which the armature conductors cut lines of force, and therefore the current $I_a = (E_a - E_b)/R_a$, see page 79, decreases. The motor will stop accelerating when this current has dropped to such a value that the total force developed is just sufficient to overcome the retarding force.

If now the load on the motor is increased, the driving force due to the armature current is not sufficient to overcome the increased resisting force and the motor must slow down. As the speed

decreases, however, the back e.m.f. E_b also decreases and allows a larger current to flow through the armature, since $I_a = (E_a - E_b)/R_a$. The motor finally settles down to such a speed that the increased current in the armature again produces a driving force which is just sufficient to overcome the increased retarding force.

If the load on the motor is decreased, the driving force due to the armature current is more than sufficient to overcome the decreased resisting force and the motor must accelerate. As it increases in speed, however, the back e.m.f. E_b also increases and causes the armature current I_a to decrease. The motor stops accelerating and the speed and armature current remain constant when the driving force due to the current has dropped to such a value that it is just sufficient to overcome the decreased retarding force. The electrical power taken by the motor from the mains therefore changes automatically to suit the mechanical load on the motor. The back e.m.f. of the

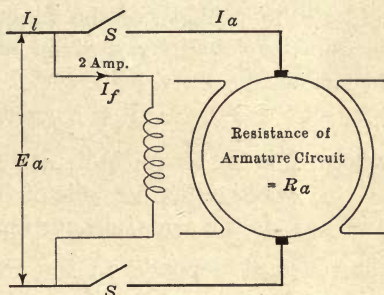

FIG. 105.

motor regulates the flow of current in the same way as the governor regulates the flow of steam in a steam engine.

A 110-volt direct-current motor, connected to the mains as shown in Fig. 105 delivers 10 h.p. If the efficiency is 88 per cent., the exciting current is 2 amp. and the armature resistance is 0.08 ohms find:

- a. The motor input
- b. The current taken from the mains
- c. The armature current
- d. The back e.m.f.

a. the motor output = 10 h.p.

$$\begin{aligned} \text{the motor input} &= \frac{\text{output}}{\text{efficiency}} \\ &= \frac{10}{0.88} = 11.35 \text{ h.p.} \\ &= 11.35 \times 746 = 8480 \text{ watts} \end{aligned}$$

$$\begin{aligned} \text{b. } I_l, \text{ the current from the mains} &= \frac{\text{watts input}}{\text{applied voltage}} \\ &= \frac{8480}{110} = 77 \text{ amp.} \end{aligned}$$

c. the armature current = the total current - the exciting current
 $= 77 - 2 = 75$ amp.

d. the applied voltage $= 110$
 the voltage to overcome the resistance drop $= I_a R_a$
 $= 75 \times 0.08$
 $= 6$ volts

the back e.m.f. $E_b = E_a - I_a R_a$
 $= 110 - 6$
 $= 104$ volts.

90. Speed and Torque Formulæ.—The force on a conductor carrying current in a magnetic field is proportional to the current and to the strength of the magnetic field, see page 7, so that the torque developed by a given motor may be expressed by the equation

$$T = a \text{ const.} \times \phi \times I_a$$

where T is the torque in lb. at 1 ft. radius, or in kg. at 1m. radius
 ϕ is the flux per pole of the motor
 I_a is the armature current

the constant depends on the construction of the machine and on the units chosen, but with its actual value we are not concerned.

When a motor is running, the back e.m.f. is always less than the applied e.m.f. by $I_a R_a$ the armature resistance drop, see page 79, so that

$$E_b = E_a - I_a R_a$$

Now E_b is generated in the motor armature because the conductors are cutting lines of force, see page 79, so that, in a given machine, E_b is proportional to the flux per pole and to the speed or

$$E_b = k \phi \text{ r.p.m. where } k \text{ is a constant}$$

and $E_b = E_a - I_a R_a$ as shown above

therefore r.p.m. $= \frac{E_b}{k \phi}$
 $= a \text{ const.} \times \frac{(E_a - I_a R_a)}{\phi}$

where r.p.m. is the motor speed in revolutions per minute
 E_a is the voltage applied at the motor terminals
 $I_a R_a$ is the armature resistance drop.
 ϕ is the flux per pole of the motor.

These speed and torque formulæ will be used in the next chapter for the determination of the characteristics of different types of motors.

91. Improvement of Commutation by Shifting of the Brushes.—

In a direct-current generator the brushes are shifted from the neutral in the direction of motion so that the coil in which the current is being reversed is in what has been called a reversing field, see page 65; in the case of the generator shown in diagram A Fig. 106, this reversing field is under the tip of the north pole.

The same machine operating as a motor is shown in diagram B, the direction of motion and the polarity of the poles being unchanged, while the direction of the current is reversed in order to make the motor rotate in the desired direction. If then the reversing field for the conductor at brush B of the generator

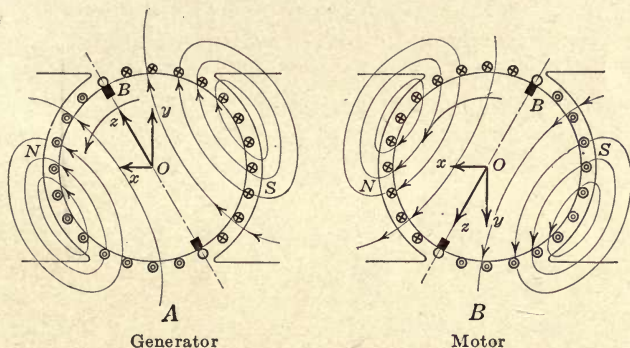

FIG. 106.—Armature magnetic field in a generator and in a motor.

is under tip of the *N* pole, that for the conductor at the same brush of the motor must be under the tip of the *S* pole since the motor is running in the same direction as the generator but with a reversed current. From this result the rule is obtained that in a generator the brushes should be shifted forward in the direction of motion whereas in a motor they should be shifted backward against the direction of motion.

92. Armature Reaction in Generators and Motors.—In Fig. 106, which shows a generator and a motor respectively with the brushes shifted so as to improve commutation, the distribution of magnetic flux due to the armature acting alone is as shown by the lines of force. The armature field acts in the direction *oz* and may be considered as the resultant of a cross-magnetizing component in the direction *oy* and of a demagnetizing component in

the direction ox , see page 68, and, in the case of both the generator and the motor, the most important effects of the reaction of the armature field on that due to the exciting current in the field coils are, that the demagnetizing effect reduces the flux per pole, while the cross-magnetizing effect causes the flux density to decrease under the pole tips toward which the brushes have been shifted, a condition which tends to cause poor commutation, see page 68.

CHAPTER XV

CHARACTERISTICS OF DIRECT-CURRENT MOTORS

SHUNT-WOUND MOTORS

93. The Starting Torque.—The shunt motor is connected to the power mains as shown diagrammatically in Fig. 107. The applied voltage E_a and the exciting current I_f are constant and are independent of the armature current I_a .

To start such a machine, the field coils are fully excited so that the magnetic flux has its normal value and then the resistance R_s is gradually decreased and current allowed to flow through the armature. The torque developed increases directly as the armature current is increased and the motor will start to rotate when the current has such a value that the torque developed is large enough to overcome the resisting torque of friction and of the load.

The torque developed, being equal to $k\phi I_a$, see page 82, depends only on the flux per pole and on the armature current and, since the exciting current and therefore the flux per pole are constant, full-load current in the machine produces the same torque at starting as when the motor is running at full-load and normal speed, or full-load torque is developed with full-load current; similarly twice full-load torque is developed with twice full-load current in the armature.

94. The Starting Resistance.—If a motor armature at standstill were connected directly to the power mains then, since its resistance is small, a large current would flow through the armature and burn the windings and the brushes. To limit the starting current, a starting resistance must be inserted in series with the armature as shown in Fig. 107 and, if full-load torque is required at starting, this resistance must limit the current to its normal full-load value.

As soon as the armature begins to rotate, a back e.m.f. is generated in it which tends to make the current decrease since $I_a = \frac{(E_a - E_b)}{(R_a + R_s)}$ but, to maintain full-load torque until the

motor is up to speed, full-load current must be maintained in the armature, so that the starting resistance must gradually be decreased as the motor comes up to speed and the back e.m.f. increases.

A 10-h.p., 110 volt, direct-current shunt motor has an efficiency of 88 per cent., an exciting current of 2 amp. and an armature resistance of 0.08 ohms find:

- a. The starting resistance required for full-load torque
- b. The starting current if no starting resistance was used

$$\begin{aligned} \text{a. the motor input} &= \frac{\text{output}}{\text{efficiency}} \\ &= \frac{10}{0.88} = 11.35 \text{ h.p.} \\ &= 11.35 \times 746 = 8480 \text{ watts} \end{aligned}$$

$$\begin{aligned} \text{the current from the mains} &= \frac{\text{watts input}}{\text{applied voltage}} \\ &= \frac{8480}{110} = 77 \text{ amp.} \end{aligned}$$

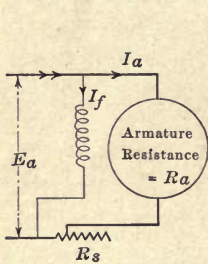

FIG. 107.—Connections of a shunt motor during starting.

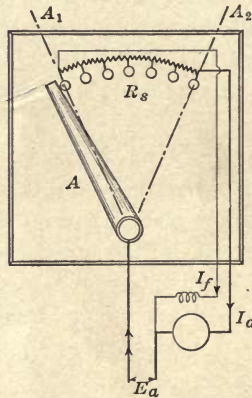

FIG. 108.—Starter for a shunt motor.

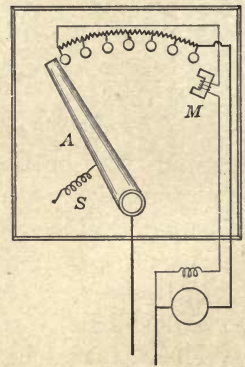

FIG. 109.—Starter with a no-voltage release.

$$\begin{aligned} \text{the armature current} &= \text{the total current} - \text{the exciting current} \\ &= 77 - 2 = 75 \text{ amp.} \end{aligned}$$

$$\begin{aligned} \text{the total resistance at starting} &= \frac{\text{applied voltage}}{\text{full-load armature current}} \\ &= \frac{110}{75} = 1.47 \text{ ohms.} \end{aligned}$$

$$\begin{aligned} \text{the starting resistance} &= \text{the total resistance} - \text{the armature resistance} \\ &= 1.47 - 0.08 \\ &= 1.39 \text{ ohms} \end{aligned}$$

b. the starting current if no starting resistance is used

$$\begin{aligned}
 &= \frac{\text{applied voltage}}{\text{armature resistance}} \\
 &= \frac{110}{0.08} = 1380 \text{ amp.} \\
 &= 18.4 \text{ times full-load current, which would burn up} \\
 &\quad \text{the winding.}
 \end{aligned}$$

95. Motor Starter.—A starter which may be used to perform the operations described above is shown diagrammatically in Fig. 108. When the handle A , which is made of metal, is moved into position A_1 , the field coils are fully excited while the armature and the whole starting resistance are put in series across the power mains. As the handle is gradually moved over to position A_2 , the starting resistance is gradually cut out of the armature circuit, but the current I_f in the field coils remains practically unchanged since the starting resistance R_s is small compared with R_f , the resistance of the field coils; in the above problem, for example, $R_s = 1.39$ ohms while $R_f = \frac{E_a}{I_f} = \frac{110}{2} = 55$ ohms.

The starting handle must not be moved over too rapidly, or the starting resistance will be cut out before the speed and therefore the back e.m.f. have time to increase and limit the current. The handle however must not be left on one of the intermediate notches between A_1 and A_2 because, in order to keep down the cost of the starting resistance, it is made small and will not carry full-load current without injurious heating for more than about 15 sec.

96. No-voltage Release.—Suppose that a motor is running at normal speed and that the power supply is interrupted due to some trouble in the power house or in the line, the motor will stop, but the starting handle will remain in the running position. If the power supply is now re-established, the armature will be at standstill and there will be no starting resistance in series with it to limit the current. To take care of such a contingency the starter is changed by the addition of what is called the no-voltage release. A starter with this attachment is shown diagrammatically in Fig. 109. The starting handle is moved from the starting to the running position against the tension of the spring S and is held in the running position by the electromagnet M . If the power supply is now interrupted, the exciting current will decrease, the magnet M will not be able to hold the handle

against the pull of the spring, and the handle will be pulled back to the starting position. The magnet M is generally so designed that it will release the starting handle should the applied voltage drop below 30 per cent. of its normal value. Such starters are described more fully in Chapter 19, page 114.

97. Load Characteristics.—The characteristic curves of a motor show how the torque and the speed vary with the armature current, the applied voltage being constant. These curves may readily be determined from the formulæ:

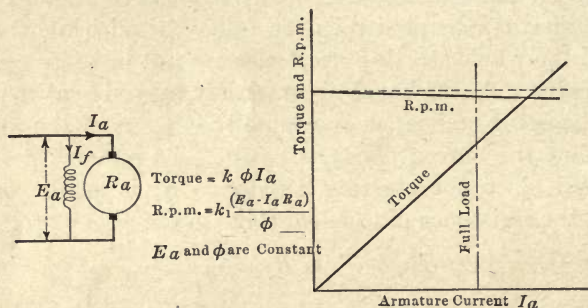

FIG. 110.—Characteristic curves of a shunt motor.

$$\begin{aligned} \text{torque} &= k \phi I_a \\ \text{r.p.m.} &= k_1 \frac{(E_a - I_a R_a)}{\phi} \end{aligned}$$

where E_a is the applied voltage

I_a is the armature current in amperes

R_a is the armature resistance in ohms

$I_a R_a$, the armature resistance drop, seldom exceeds 5 per cent. of E_a when the motor is carrying full-load

ϕ is the flux per pole

k and k_1 are constants

In the case of the shunt motor, see Fig. 110, the applied voltage E_a and the exciting current I_f are constant and so also is the flux per pole, the effect of armature reaction being neglected, then:

$$\begin{aligned} \text{torque} &= k \phi I_a \\ &= \text{a const.} \times I_a \\ \text{r.p.m.} &= k_1 \frac{(E_a - I_a R_a)}{\phi} \\ &= \text{a const.} (E_a - I_a R_a) \end{aligned}$$

The curves corresponding to these equations are shown in Fig. 110. The full-load speed is less than that at no-load by about 5 per cent. since the back e.m.f. E_b has to drop this amount in order that full-load current may flow through the armature.

98. Effect of Armature Reaction on the Speed.—When the effect of armature reaction is neglected, the speed characteristic of a shunt motor is as shown in Fig. 110; the drop in speed seldom exceeds 5 per cent. at full-load. When the brushes are shifted backward from the neutral so as to improve commutation, armature reaction causes the flux per pole to decrease as the load increases, see page 84, so that the speed, being equal to $k(E_a - I_a R_a)/\phi$ remains approximately constant from no-load to full-load, since the decrease in the value of $(E_a - I_a R_a)$ is compensated for by the decrease in the value of ϕ .

Shunt motors are suited for constant-speed work such as the driving of line shafts and wood-working machinery.

99. Variable speed operation can best be investigated by means of the equation r.p.m. = $k(E_a - I_a R_a)/\phi$, see page 82.

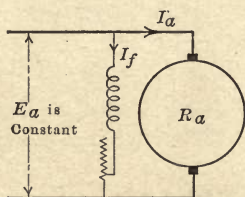

FIG. 111.—Insert resistance in the field circuit to increase the speed.

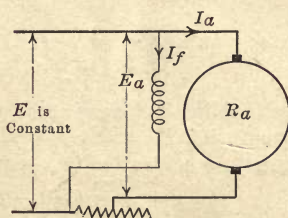

FIG. 112.—Insert resistance in the armature circuit to decrease the speed.

Methods of adjusting the speed of a shunt motor.

To increase the speed, ϕ the flux per pole must be reduced by inserting a resistance in series with the field coils as in Fig. 111. To decrease the speed below the value which it has when the flux per pole is a maximum, the voltage E_a applied to the motor terminals must be decreased by inserting a resistance in series with the armature as shown in Fig. 112; this resistance must be able to carry the full-load current without injury so that the starting resistance must not be used since it is designed for starting duty only, see page 87.

While the formula shows that the speed increases when the

flux ϕ is decreased, it is advisable to study more fully how this takes place. If the flux per pole is suddenly decreased, the back e.m.f. of the motor drops and allows more current to flow in the armature. The increase in the armature current is greater than the decrease in the flux, so that the torque developed is greater than necessary for the load and the motor accelerates. The following problem illustrates this.

A 10-h.p., 110 volt, 900 r.p.m. direct-current shunt motor has an armature resistance of 0.08 ohms and takes an armature current of 75 amp. at full load. Find:

- a. The torque at full-load
 - b. The back e.m.f. at full-load
- If the flux per pole is suddenly reduced to 80 per cent. of normal find:
- c. The back e.m.f. at the instant the flux is changed
 - d. The armature current at the same instant
 - e. The torque at the same instant

$$\begin{aligned}
 a. \text{ the torque} &= \frac{\text{horse-power} \times 33,000}{2\pi r.p.m.} \\
 &= \frac{10 \times 33,000}{2\pi 900} = 58.5 \text{ lb. at 1 ft. radius}
 \end{aligned}$$

$$\begin{aligned}
 b. \text{ the back e.m.f. } E_b &= E_a - I_a R_a \\
 &= 110 - (75 \times 0.08) = 104 \text{ volts at full-load}
 \end{aligned}$$

At the instant the flux is reduced

$$c. \text{ the back e.m.f. } E_b = 104 \times 80/100 = 83.2 \text{ volts, since } \phi \text{ is reduced}$$

$$\begin{aligned}
 d. \text{ the armature current} &= (E_a - E_b)/R_a \\
 &= (110 - 83.2)/0.08 \\
 &= 335 \text{ amp. or 4.46 times full-load current}
 \end{aligned}$$

$$\begin{aligned}
 e. \text{ the torque} &= 58.5 \times 80/100 \times 335/75, \text{ since it is proportional to the} \\
 &\text{flux and to the armature current} \\
 &= 209 \text{ lb. at 1 ft. radius or 3.6 times full-load torque.}
 \end{aligned}$$

f. At the instant the flux per pole is reduced to 80 per cent. of its normal value, the armature current increases to 4.46 normal and the torque to 3.6 times normal value. The driving torque being then larger than the retarding torque of the load, the motor must accelerate.

SERIES-WOUND MOTORS

100. The Starting Torque.—The series motor is connected to the power mains as shown diagrammatically in Fig. 113. The applied voltage E_a is constant while the field excitation increases with the load.

The torque developed, being equal to $k\phi I_a$, see page 82, increases directly with ϕ the flux per pole and with I_a the armature current. Now ϕ increases with I_a since that current is also the exciting current and, if the magnetic circuit of the machine is not saturated, ϕ is directly proportional to I_a and the torque is therefore proportional to I_a^2 . In an actual motor, the flux per pole does not increase as rapidly as the exciting current, due to saturation of the magnetic circuit, but varies with I_a as shown in curve 1, Fig. 113. Using this relation between ϕ and I_a , the relation between torque ($k\phi I_a$) and I_a has been determined and is plotted in curve 2.

Full-load current in the machine produces the same flux per

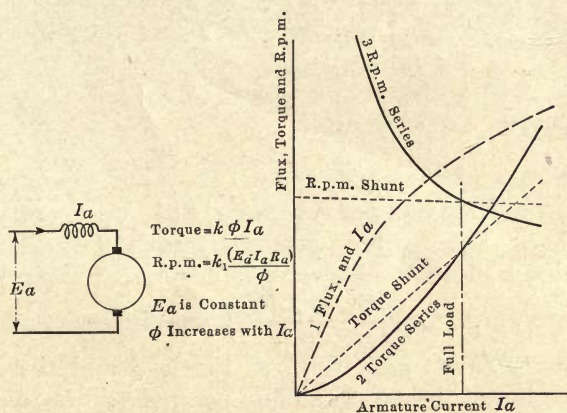

FIG. 113—Characteristic curves of a series motor.

pole and therefore the same torque at starting as when the motor is running at full-load and normal speed, or full-load torque is developed with full-load current. Since the torque is approximately proportional to I_a^2 , twice full-load torque is developed with approximately $\sqrt{2}$ times or 1.414 times full-load current. In the case of the shunt motor, the flux per pole is constant and the torque is directly proportional to I_a , see page 85, so that twice full-load torque requires twice full-load current. For heavy starting duty, therefore, the series motor is better than the shunt motor in that it takes less starting current from the line.

101. The Starting Resistance.—As in the case of the shunt motor, see page 85, a starting resistance must be inserted in series with the armature so as to limit the starting current.

This resistance must be gradually decreased as the motor comes up to speed.

102. Load Characteristics.—The characteristic curves of a series motor may readily be determined from the fundamental formulæ:

$$\begin{aligned}\text{torque} &= k\phi I_a \\ \text{r.p.m.} &= k_1 \frac{(E_a - I_a R_a)}{\phi}\end{aligned}$$

where E_a is the applied voltage
 I_a is the armature current in amperes
 R_a is the combined resistance of the armature and the series field coils
 $I_a R_a$, the armature and series field drop, seldom exceeds $\frac{7}{100}$ per cent. of E_a when the motor is carrying full-load
 ϕ is the flux per pole
 k and k_1 are constants

In the case of the series motor, the applied voltage E_a is constant, while the flux per pole varies with I_a as shown in curve 1, Fig. 113. The relation between torque ($k\phi I_a$) and armature current is plotted in curve 2, while curve 3 shows the relation between r.p.m. ($k_1 \frac{(E_a - I_a R_a)}{\phi}$) and the armature current.

It is important to note that, as the load and therefore the armature current decrease, the flux per pole decreases and the machine must speed up to give the required back e.m.f. At light loads the speed becomes dangerously high and for this reason a series motor should always be geared or direct connected to the load. If a series motor were belted to the load and the belt broke or slipped off, then the motor would run away and would probably burst.

Series motors are suited for crane work because they develop a large starting torque, slow down when a heavy weight is being lifted and speed up with light loads. Crane motors are geared to the hoisting drum and are always under the control of the operator.

103. Speed Adjustment.—The speed of a series motor is proportional to $(E_a - I_a R_a)/\phi$, see page 82, so that, for a given current I_a , the speed may be changed by altering E_a the applied voltage, or ϕ the flux per pole.

If a resistance R_e is inserted in series with the armature as shown in Fig. 114, then the voltage applied at the motor terminals is reduced by $I_a R_e$ and the lower back e.m.f. required is obtained at a lower speed.

With constant applied voltage and a given armature current the speed may be increased by decreasing the flux per pole. This may be done as shown in Fig. 115 by shunting the series field winding with a resistance so that, of the total current I_a , only part is allowed to pass through the field winding. The flux per pole may also be reduced by short circuiting part of the field winding as shown in Fig. 116, if the switch S is closed, the current

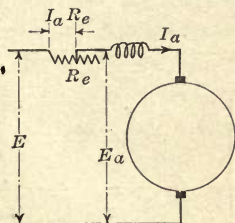

FIG. 114.

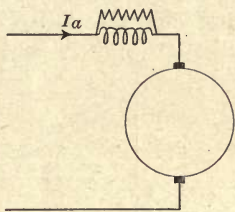

FIG. 115.

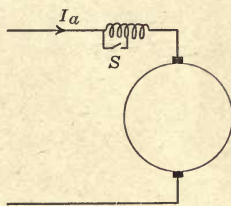

FIG. 116.

FIG. 114—Insert resistance in the armature circuit to reduce the speed.

FIG. 115.—Shunt the field coils to reduce the excitation and increase the speed.

FIG. 116—Short circuit part of the field winding to reduce the excitation and increase the speed.

Methods of adjusting the speed of a series motor.

passing through the machine is not changed so long as the load is kept constant, but the exciting ampere turns are reduced and so therefore is the flux per pole.

COMPOUND MOTORS

104. The compound motor is a compromise between the shunt and the series motor and is connected to the power mains as shown diagrammatically in Fig. 117. The applied voltage E_a is constant and so also is the shunt current I_f , but the current in the series field coils increases with the load, so that the flux per pole increases with the load but not so rapidly as in the series motor.

If a shunt and a compound motor have duplicate armatures and the same excitation at full-load, then at this load they will

develop the same torque and run at the same speed since

$$\begin{aligned} \text{torque} &= k c I_a \\ \text{r.p.m.} &= \frac{1}{k_1} \frac{(E_a - I_a R_a)}{\phi} \end{aligned}$$

For loads greater than full-load, the flux per pole of the shunt motor is unchanged while that of the compound motor is increased due to the series field coils, therefore the compound motor has the greater torque but the lower speed. For loads less than full-load on the other hand, the flux per pole of the compound motor is less than that of the shunt motor due to the decrease of the current in the series field coils, so that the torque is less and the speed is greater than in the shunt machine.

The speed and torque characteristics of a compound motor

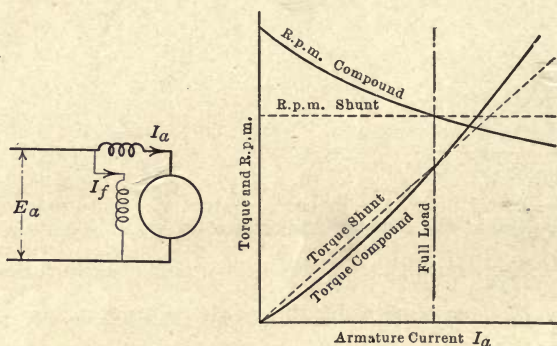

FIG. 117.—Characteristic curves of compound motors.

are shown in Fig. 117. Unlike the series motor, the compound motor has a safe maximum speed at no-load and so cannot run away on light loads. The speed of a compound motor may be decreased below normal by means of a resistance inserted in the armature circuit, and increased above normal by means of a resistance in the field coil circuit.

Compound motors are suitable for driving such machines as rock crushers which may have to be started up full of rock, because they develop the large starting torque with a smaller current than the shunt motor, while they drop in speed as the load comes on and thereby allow a flywheel connected to the shaft to take the peak of the load.

CHAPTER XVI

LOSSES, EFFICIENCY AND HEATING

105. Mechanical Losses in Electrical Machinery.—In order to keep the armature of an electrical machine rotating, power is required to overcome the windage or air friction, the bearing friction, and the friction of the brushes on the commutator. This power is not available for useful work and is called the mechanical loss in the machine.

In a given machine this loss increases with the speed, but at a given speed it is practically independent of the load.

106. Copper Losses.—If R_a is the resistance of the armature circuit, including the armature winding, the brush contacts, and the series field coils then, to force a current I_a through this circuit, a voltage $e_a = I_a R_a$ is required. This armature circuit drop at full-load seldom exceeds 5 per cent. of E_t , the terminal voltage.

The power expended in overcoming this voltage drop is equal to $e_a I_a = I_a^2 R_a$ watts and, since this power is not usefully employed, it is called the copper loss in the armature circuit.

If again, R_f is the resistance of the shunt field coil circuit, Fig. 118, and I_f is the shunt current, then the power expended in exciting the machine is equal to $I_f^2 R_f$ watts where I_f , which is equal to E_t / R_f , seldom exceeds 5 per cent. of the current in the armature of the machine.

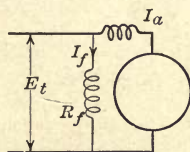

FIG. 118.

107. Hysteresis Loss.—Fig. 119 shows an armature which is rotating in a two-pole magnetic field. If we consider a small block of iron ab then, when it is under the N pole as shown, lines of force pass through it from a to b ; half a revolution later the same piece of iron is under the S pole and the lines of force then pass through it from b to a so that the magnetism in the iron is reversed. To continually reverse the molecular magnets of the iron in the armature an amount of power is required which is called the hysteresis loss in the machine, see page 36.

The hysteresis loss increases with the number of reversals per

second, that is with the speed, it also increases with the flux density.

108. Eddy Current Loss.—If the armature *A*, Fig. 119, were made of a solid block of iron then, as it rotated, e.m.fs. would be induced in the surface layers of the iron and eddy currents would flow through the solid mass, see page 55. The power required

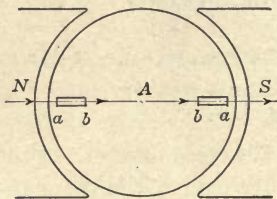

FIG. 119.—Reversal of flux in the armature core as the armature rotates.

to maintain these currents is called the eddy current loss in the armature and is kept below 3 per cent. of the armature output by lamination of the core, see page 58.

Since the e.m.fs. generated in the eddy current circuits depend on the rate of cutting lines of force, the eddy current loss will increase with the speed and with the flux density.

109. Stray Loss.—The total loss in a direct-current machine consists of

Stray loss	{	Mechanical losses	{	Windage
		Iron losses		Bearing friction
Copper loss				Brush friction
				Hysteresis loss
				Eddy current loss
				$I_a^2 R_a + I_f^2 R_f$

The term stray loss is used in practice to include the mechanical and the iron losses. These losses do not vary with the load so that they have practically the same value at no-load as at full-load. The stray loss can readily be measured at no-load by running the machine idle as a motor at normal speed and normal voltage. The motor armature input $E_t I_a$, Fig. 120, is then equal to the mechanical losses, the iron losses and the small no-load armature circuit copper loss, which latter loss may be neglected as may be seen from the following problem:

If a 50-kw., 110-volt, shunt generator requires an armature current of 30 amp. when run as a motor at no-load and normal speed and voltage, find the stray loss, the resistance of the armature circuit being 0.008 ohms.

$$\begin{aligned}
 \text{The armature input at no-load} &= 110 \times 30 = 3300 \text{ watts} \\
 &= \text{stray loss} + I_a^2 R_a \\
 &= \text{stray loss} + (30^2 \times 0.008 = 7.2)
 \end{aligned}$$

from which the stray loss = 3300 - 7 = 3293 watts.

In the case of large machines, the stray loss is generally determined by driving the machine at normal voltage and speed by means of a small shunt motor the losses of which are known. The machines are connected up as shown in Fig. 121, the generator is then excited to give normal voltage E_o and the input to the small motor armature is determined from readings of the voltage E_m and the current I_a . Under these conditions the input to the generator must be equal to the windage, friction and iron losses of the machine and this input is also equal to $E_m I_a$ minus the motor losses, which latter losses are known.

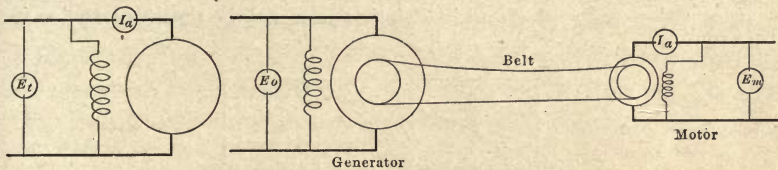

FIG. 120.—Machine runs idle as a motor. FIG. 121.—Machine driven by a small motor the efficiency of which is known.

Measurement of the stray loss in a direct-current machine.

110. The efficiency of a machine = output/input and may be calculated from test data as in the following example.

Draw the efficiency curve for a direct-current flat-compounded generator rated at 1000 kw., 600 volts, given the following data
stray loss = 30 kw.

R_a = the resistance of the armature winding, brush contacts and series field coils = 0.006 ohms

R_f = the resistance of the field coil circuit = 20 ohms

At full-load, the load current = $\frac{1000 \times 1000}{600} = 1666$ amp.

of which I_f , the shunt field current = $\frac{600}{20} = 30$ amp.

and I_a , the armature current = 1696 amp.

then the stray loss = 30 kw.

$$I_f^2 R_f = 30^2 \times 20 = 18 \text{ kw.}$$

$$I_a^2 R_a = 1696^2 \times 0.006 = 17.2 \text{ kw.}$$

total loss = 65.2 kw.

generator output = 1000 kw.

generator input = 1065.2 kw.

full-load efficiency = 94 per cent.

The mechanical losses, the iron losses and the shunt field copper loss are all independent of the load on the machine and are often classed together as the

constant loss, the variable loss being $I_a^2 R_a$ the loss in the armature circuit, so that at half-load, the load current = $\frac{500 \times 1000}{600} = 833$ amp.

of which the shunt field current = 30 amp.
and the armature current = 863 amp.

then the stray loss = 30 kw.

$$I_f^2 R_f = 18 \text{ kw.}$$

$$I_a^2 R_a = 863^2 \times 0.006 = 4.5 \text{ kw.}$$

total loss = 52.5 kw.

generator output = 500 kw.

generator input = 552.5 kw.

half load efficiency = 90.5 per cent.

Other values are worked out in a similar way and the results plotted as in Fig. 122.

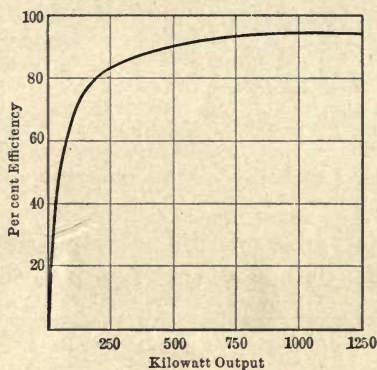

FIG. 122.—Efficiency curve of a 1000 kw., 600 volt direct-current generator.

Approximate values for the full-load efficiency of standard generators and motors are:

Kilowatts	Full-load efficiency
1	80 per cent.
5	83 " "
25	88 " "
100	91 " "
500	94 " "
1000	95 " "

The efficiency of a motor may be determined by loading the motor with a prony brake and measuring the total electrical input and the corresponding mechanical output. Such a test however is rarely carried out except in the case of small motors, the effi-

ciency of large machines is more readily determined from measurements of the losses and is worked up as in the last problem.

111. Heating of Electrical Machinery.—The losses in an electrical machine are transformed into heat which causes the temperature of the machine to rise above that of the surrounding air. The temperature becomes stationary when the rate at which heat is generated is equal to the rate at which it is dissipated.

The rate at which heat is dissipated depends on the difference between the temperature of the machine and that of the surrounding air. During the brief interval after starting under load this temperature difference is small, very little heat is dissipated and the temperature rises rapidly as shown in Fig. 123. As the temperature increases, more of the heat is dissipated and the temperature rises more slowly as from *b* to *c*. If the load is now taken off the machine, the temperature will drop rapidly at first

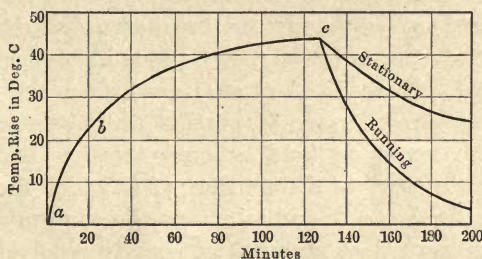

FIG. 123.—Heating curves of electrical machines.

and then more slowly as shown in Fig. 123, the temperature drop being more rapid when the machine is rotating than when stationary because of the better ventilation and the better convection of heat.

112. Permissible Temperature Rise.—Insulating materials lose their mechanical and dielectric strengths at high temperatures, for example, cotton becomes brittle at temperatures greater than 85° C. and begins to char at slightly higher temperatures, so that, when cotton is used to insulate machines, the permissible rise of temperature is 50° C. above an air temperature of 35° C.

Methods of insulating have been devised whereby cotton, paper and other materials that become brittle and char are not used, fireproof materials such as enamel, asbestos and mica being used entirely, with such insulation higher temperatures are permissible.

CHAPTER XVII

MOTOR APPLICATIONS

113. Limits of Output.—If the load on a motor is increased, the armature current and the armature copper loss both increase and the temperature of the machine rises. The maximum load that can be put on a motor is that with which the temperature of the machine reaches its safe maximum value; a greater load raises the temperature to such a value that the insulation of the machine is permanently injured.

The output of a motor is often limited by commutation. When interpoles are not supplied, the brushes are shifted from the neutral so that commutation takes place in a reversing or commutating field. Now the effect of armature reaction is to weaken this reversing field, see page 84, so that as the armature current increases, the reversing field becomes weaker and the motor finally begins to spark at the brushes, after which the load can be increased no further without injury to the commutator.

If the commutation limit of output is reached before the heating limit, then interpoles may be supplied to improve commutation, see page 65, and the motor output may be increased until the temperature limit is reached.

114. Open, Semi-enclosed and Totally Enclosed Motors.—The cooling of a motor depends largely on the circulation of air through the core and windings, so that the frame should be as open as possible.

If chips and flying particles are liable to get into the windings, the openings in the frame should be covered with perforated sheet metal; the motor is then said to be semi-enclosed. This screen throttles the air supply on which the cooling of the machine largely depends so that, in order to keep down the temperature rise, the output of a motor has to be lower when semi-enclosed than when of the open type.

When a motor has to be totally enclosed, as for open-air service, the output of the machine has to be considerably reduced so as to keep the temperature down to a safe value thus:

A 10-h.p., 220-volt, 600-r.p.m. motor with 40° C. rise on full-load as an open machine can be used to deliver 9 h.p. when semi-enclosed and about 6 h.p. when totally enclosed at the same voltage and speed and with the same rise in temperature.

115. Intermittent Ratings.—It was pointed out on page 99 that it takes a considerable time for a motor to attain its final temperature so that, if a motor has to be operated intermittently for short periods, its output may be considerably increased.

With suitable windings a particular motor frame was given the following ratings

- 10 h.p., 220 volts, 600 r.p.m. continuous duty
- 17 h.p., 220 volts, 600 r.p.m. for 1 hour
- 22 h.p., 220 volts, 600 r.p.m. for 1/2 hour

the temperature rise at the end of the specified time being the same in each case.

116. Effect of Speed on the Cost of a Motor.—For a given horsepower output, a high speed motor is always cheaper than a slow speed motor thus:

A 10-h.p., 220-volt, 1200-r.p.m. shunt motor weighs 750 lb. and costs \$150.

A 10-h.p., 220-volt, 600-r.p.m. shunt motor weighs 1250 lb. and costs \$250.

A 10-h.p., 220-volt, 300-r.p.m. shunt motor weighs 1800 lb. and costs \$350.

The reason for this is as follows:

If a given motor frame is supplied with two armatures, one of which *A* has half as many conductors as *B* but the conductors have twice the cross section and can therefore carry twice the current, then, when run at the same voltage, armature *A* with half the conductors must run at twice the speed of *B* to give the same back e.m.f., but since armature *A* can carry twice the current of *B* it can therefore deliver twice the output. Thus the armature of a 10 h.p., 600 r.p.m. motor could be rewound to deliver 20 h.p. at 1200 r.p.m., 15 h.p. at 900 r.p.m. or 5 h.p. at 300 r.p.m. and these armatures would all have approximately the same weight and cost.

117. Choice of Type of Motor.—The characteristic curves of a shunt, a series, and a compound motor are shown in Fig. 124, the motors having the same torque and speed at full-load.

The shunt motor takes a current which is proportional to the

torque required, and operates at practically constant speed at all loads. It must be noted however that the speed of such a motor increases slowly as the field coils heat up because their resistance increases and causes the excitation to decrease. If the motor has been started cold, the speed may increase 10 per cent. in 3 hours due to this cause.

The series motor is the best for heavy starting duty because, for any torque greater than the full-load value, it takes a smaller current from the line than either the shunt or the compound machine. The speed of the series motor decreases rapidly with increase of load and becomes dangerously high at light loads. For this latter reason, a series motor should always be geared or direct connected to the load.

The compound motor is a compromise between the shunt and

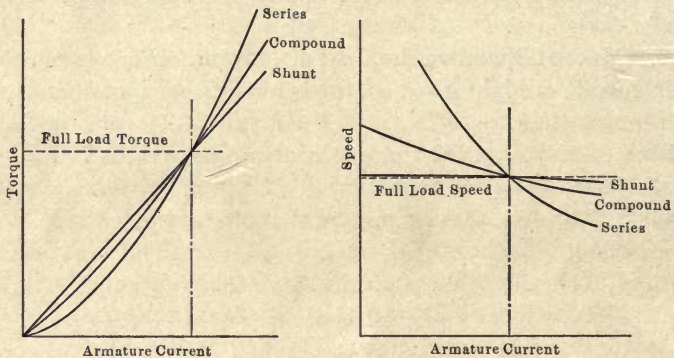

FIG. 124.—Characteristic curves of direct current motors.

the series motor. It is better than the shunt motor for heavy starting duty but not so good as the series motor. The speed drops somewhat with the load but the motor runs at a safe maximum speed even at no-load.

The service for which each type of motor is suited can best be illustrated by a discussion of a few typical motor applications.

118. A line shaft should run at practically constant speed at all loads and so is driven by a shunt motor. The starting torque required will seldom exceed 1.5 times full-load torque and this can be obtained with 1.5 times full-load current in the armature, which is a reasonable starting overload.

119. Wood-working machinery such as planers and circular saws run at practically constant speed and so are suitably

driven by shunt motors. In the case of heavy planing mills, the starting torque required is sometimes excessive due to the inertia of the machine, in which case it may be advisable to use a compound motor because it requires a smaller starting current for the same torque.

120. Reciprocating pumps, which have to start up against full pressure, require a large starting torque, so that although a shunt motor is often used for such service yet a compound motor would take less starting current from the line. A series motor would be suitable so far as starting torque is concerned, but if the suction pipe were to leak so that the load on the motor became light, then the motor would run away.

121. Traction Motors.—For traction service, the torque required to start and accelerate a car is much greater than that required to keep the car moving, so that a series motor is used since it is the best for heavy starting duty, see page 91. The subject of traction is discussed more fully in Chapter 40, page 322.

122. Crane Motors.—The characteristics which make the series motor suitable for traction work also make it suitable for crane service. The motor is able to develop a large starting torque without taking an excessive current from the line; it also operates at a slow speed when the load to be lifted is heavy and runs at a high speed when the load is light.

Both crane and traction motors are geared to the load and moreover are always under the control of the operator.

123. Express Passenger Elevators.—An express elevator has to be accelerated rapidly, so that a large starting torque is required. After the car has moved through about 20 ft., its velocity has reached about 500 ft. per min., and has to be kept constant at this value. This result is obtained by the use of a heavily compounded motor, by means of which a large starting torque is developed without an excessive current being taken from the line; when acceleration is complete, the series winding is short circuited, and the motor operates thereafter as a constant speed shunt machine.

A series motor would not be suitable for such service because, during the rush hours when the car is heavily loaded the motor would slow down, whereas at times of light load the car would run at an excessive speed, unless specially controlled.

124. Shears and Punch Presses.—The load curve of a punch press is shown in Fig. 125. In order that the peak load may be

carried by the motor without sparking, a motor of about 15 h.p. would be required, which is much greater than the average load of 6.5 h.p. To take the peak load off the motor, a flywheel is generally supplied with the press and, in order that the flywheel may be effective, the speed of the motor must drop as the load comes on.

A shunt motor is not suitable for such service as it does not drop in speed and so does not cause the flywheel to take the load.

A series motor cannot be used because it would run away when the clutch of the press was released, and would probably cause the flywheel to burst.

The motor generally used on large presses is compound wound, which motor drops in speed as the load comes on and thereby causes the flywheel to give up energy, while the maximum speed at no-load cannot exceed a safe value.

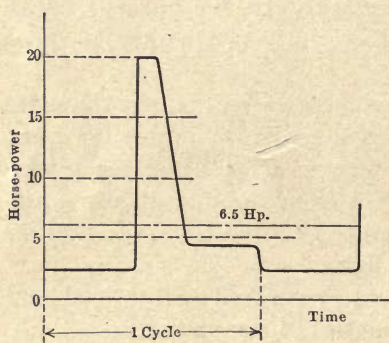

FIG. 125.—Load curve of a punch press.

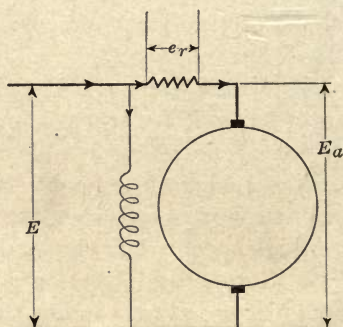

FIG. 126.

A drooping speed characteristic may be obtained from a shunt motor by connecting a resistance permanently in series with the armature as shown in Fig. 126, the resistance having such a value that the voltage drop e_r at full-load is about 5 per cent. of E . When the load on the motor increases, the voltage drop across the resistance increases, that applied to the motor terminals decreases, and the speed of the motor drops. When the load on the motor decreases, the voltage across the motor increases, the speed rises, and energy is again stored in the flywheel. The resistance in the power mains supplying the motor may often be sufficient to produce this effect. The only objection to the method is that an amount of power $= e_r I_a$ watts is lost in the control resistance.

CHAPTER XVIII

ADJUSTABLE SPEED OPERATION OF DIRECT-CURRENT MOTORS

For the driving of lathes and other such machine tools, adjustable speed motors are largely used, it is therefore necessary to discuss the different methods of speed control before the subject of machine tool driving can be profitably taken up.

125. Speed Variation of Shunt Motors by Armature Control.—

The speed of a motor may be lowered by decreasing the voltage

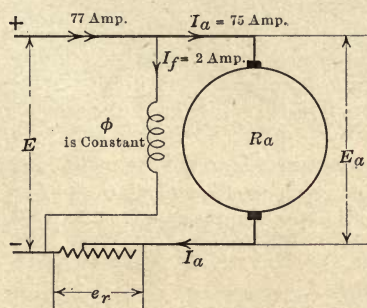

FIG. 127.—Resistance inserted in the armature circuit causes the speed to decrease.

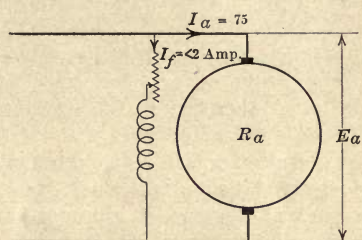

FIG. 128.—Resistance inserted in the field coil circuit causes the speed to increase.

Methods of adjusting the speed of a direct current shunt motor.

applied to the motor terminals. This may be done by connecting a resistance in the armature circuit as shown in Fig. 127.

The speed is given by the formula $\text{r.p.m.} = k_1 \frac{(E_a - I_a R_a)}{\phi}$ where $I_a R_a$ seldom exceeds 5 per cent. of E_a , so that, to obtain half speed, the applied voltage E_a must be reduced to about 50 per cent. of normal, the other 50 per cent. of the line voltage being absorbed by the resistance inserted in the circuit; under these conditions, the loss in the resistance, which is equal to $e_r I_a$, is also equal to the armature input $E_a I_a$, and the efficiency of the system is less than 50 per cent. The actual efficiency may be figured out as in the following problem.

A 10-h.p., 110-volt, 900-r.p.m. shunt motor has an efficiency of 88 per cent., an armature resistance of 0.08 ohms and a shunt field current of 2 amp. If the speed of this motor is reduced to 450 r.p.m. by inserting a resistance in the armature circuit, the torque of the load being constant, find the motor output, the armature current, the external resistance and the overall efficiency.

At normal load:

the motor output = 10 h.p.
 the motor input = $10/0.88 = 11.35$ h.p. = 8480 watts
 the total current = $8480/110 = 77$ amp.
 the shunt current = 2 amp.
 the armature current = 75 amp., see page 82
 the torque = $\frac{10 \times 33,000}{2 \times \pi \times 900} = 58.5$ lb. at 1 ft. radius, see page 90
 the back e.m.f. = $E_a - I_a R_a$
 = $110 - (75 \times 0.08) = 104$ volts, see page 82.

At half speed:

The horsepower output = $\frac{\text{torque} \times 2\pi \text{ r.p.m.}}{33,000}$ and, since the torque is constant, the output is proportional to the speed and is equal to 5 h.p.

The torque = $k\phi I_a$, and, since the torque is constant and so also is the excitation, therefore I_a , the armature current, is the same as at full speed and is equal to 75 amp.

The back e.m.f. E_b is generated in the armature due to the cutting of lines of force and is equal to a const. $\times \phi \times \text{r.p.m.}$, see page 82, and since the flux is constant, therefore E_b is proportional to the speed and is equal to $0.5 \times 104 = 52$ volts.

The voltage applied to the motor = $E_b + I_a R_a$
 = $52 + (75 \times 0.08)$
 = 58 volts.

The voltage drop across the external resistance = $110 - 58$
 = 52 volts

the current in this resistance = 75 amp.

the resistance = $52/75 = 0.7$ ohms.

the loss in the resistance = $52 \times 75 = 3900$ watts.

the total input = $110 \times (75 + 2)$, see Fig. 127, = 8500 watts.

the motor output = 5 hp. = $5 \times 746/1000 = 3.7$ kw.

the overall efficiency = $3.7/8.5 = 44$ per cent.

Since the armature current and therefore the armature copper loss have the same value at half speed as at full speed, the torque being constant, the temperature rise will be the greater at the slow speed because of the poorer ventilation.

From the above problem it may be seen that, when the speed of a motor is reduced by armature resistance, the output is decreased and is directly proportional to the speed while the temperature

rise, even with this reduced output, is greater than normal because of the poorer ventilation. The overall efficiency also is exceedingly low, the per cent. loss in the resistance being approximately equal to the per cent. reduction in speed, that is, being 50 per cent. of the total input at half speed and 75 per cent. of the total input at quarter speed.

126. Speed Variation of Shunt Motors by Field Control.—

By inserting a resistance in the field coil circuit of a shunt motor, as in Fig. 128, the excitation and therefore the magnetic flux are reduced and the motor has to run at a higher speed in order to generate the necessary back e.m.f., see page 89.

When interpoles are not supplied, the brushes are shifted from the neutral position so that commutation takes place in a reversing field, but if the excitation is decreased, then this reversing field is decreased and the commutation is impaired; furthermore, the higher the speed, and therefore the more rapidly the current in the coils is being commutated, the greater is the voltage of self induction opposing the change of current and the greater the tendency for sparking to take place at the brushes, see page 63. The range of speed variation is therefore limited by commutation and an increase in speed of about 70 per cent. is about all that can generally be obtained by field weakening from a standard motor; the flux is then reduced to $1/1.7 = 60$ per cent. of its normal value. When a greater speed range is required, it will generally be necessary to use an interpole motor.

When the speed is controlled by a field rheostat the efficiency is not impaired because, as shown in Fig. 128, the control rheostat carries only the small shunt current and not the large armature current.

127. Speed Regulation of an Adjustable Speed Shunt Motor.—

When the speed of a motor varies considerably with change of load the speed regulation is said to be poor. When the speed is practically constant at all loads the speed regulation is said to be good.

Suppose that the speed of a shunt motor has been adjusted by means of a resistance in the armature circuit, as shown in Fig. 127, so as to give a definite speed at a definite load, then, when the load is increased, the armature current I_a and the voltage e_r will increase and therefore the voltage E_a will decrease and the speed of the motor will drop; the speed regulation is therefore poor when armature resistance control is used.

If, for example, this method of control is used when a forging

such as that in Fig. 129 is being turned in a lathe, then the motor will slow down when the cut is deep and will speed up when the cut is light, so that the speed will be very irregular.

When the speed of a shunt motor is adjusted by means of a resistance in the field coil circuit, as in Fig. 128, the speed regulation is good. The speed is given by the formula r.p.m. = $k_1 \frac{(E_a - I_a R_a)}{\phi}$ so that since E_a is constant, as also is the flux ϕ once the field circuit resistance is adjusted, therefore the drop in speed between no-load and full-load will seldom exceed 5 per cent.,

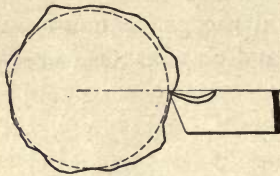

FIG. 129.

since $I_a R_a$ at full-load seldom exceeds 5 per cent. of E_a .

128. Electric Drive for Lathes and Boring Mills.—Such machines require constant horse-power at all speeds of the machine spindle so long as the amount of metal removed per minute remains unchanged. The motor must

therefore be large enough to develop the necessary horsepower at the lowest operating speed without excessive heating.

The maximum speed of a given motor is limited by centrifugal force or by the speed of the gear, while the minimum speed may be as low as desired, but when constant horsepower is required at all speeds the cost of the motor increases as the minimum speed is decreased as may be seen from the following table:

- A. A 10-h.p., 220-volt, 1200-r.p.m. shunt motor weighs 750 lb. and costs \$150.
- B. A 10-h.p., 220-volt, 600/1200-r.p.m. shunt motor weighs 1250 lb. and costs \$250.
- C. A 10-h.p., 220-volt, 300/1200-r.p.m. shunt motor weighs 1800 lb. and costs \$390.

the latter motor is necessarily an interpole machine because of the large speed variation required, see page 107, and costs about 10 per cent. more than a constant-speed 300-r.p.m. motor of the same output.

The cheapest drive from the point of view of motor cost is that obtained by the use of a constant-speed motor such as A in the above table, with change gears or coned pulleys to give the necessary speed range. If some of the gears are eliminated, and a motor such as B in the above table is used, which has a speed range of 2 to 1, then the cost of the motor is increased 66 per cent.,

while for a speed range of 4 to 1 by motor control the cost of the motor is 2.6 times greater than if a constant speed motor with change gears had been used.

The speed range of the motor may be obtained by armature control, by field control, or by a combination of the two. Armature control is used as little as possible because of the low overall efficiency of the method and also because of the poor speed regulation obtained, see pages 105 and 107.

129. Multiple Voltage Systems.—When a large number of adjustable speed motors are in operation in a machine shop, the three wire system shown diagrammatically in Fig. 130 may be used with advantage. Two generators in the power house are connected in series and three leads *a*, *b* and *c* are taken to each

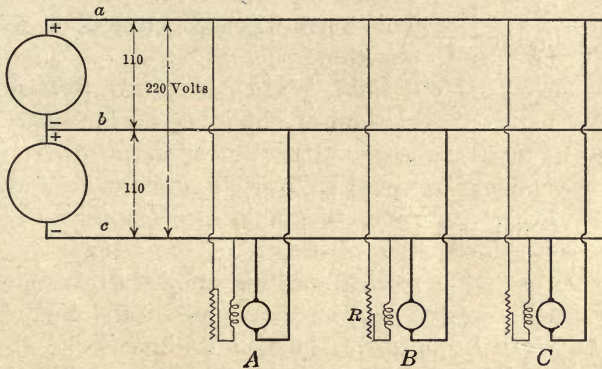

FIG. 130.—Multiple voltage system.

adjustable speed motor, the voltage between *a* and *c* being 220 and between *a* and *b* and also between *b* and *c* being 110 volts. To obtain the lowest speed from a motor operating on this system, the field coils are connected across the 220-volt mains so as to give the maximum flux while the armature is connected across either of the 110-volt circuits as shown at *A*, Fig. 130. The speed may then be gradually increased by inserting resistance *R* in the field coil circuit as shown at *B*. When the speed has been doubled in this way, the armature is then connected across the 220-volt mains and all the resistance *R* is cut out of the field coil circuit, and the speed may again be gradually increased by once more reducing the field excitation by means of the resistance *R* as shown at *C*. By this means a total speed range of 4 to 1 may be obtained without the magnetic flux being reduced at any time

to less than half its normal value, and the efficiency is high over the whole range of speed because no resistance is inserted in the armature circuit at any time.

Another multiple voltage system is shown diagrammatically in Fig. 131 and is in use in a considerable number of machine shops. The voltages available in this case are 90, 160 and 250 so that a total speed range of 4 to 1 may readily be obtained from a standard motor since the flux is never reduced below about 60 per cent. of its normal value, see page 107. The two-voltage system is to be preferred however since 110 and 220 are standard voltages and still more so because the two voltages may readily be obtained from a single machine called a three-wire generator,

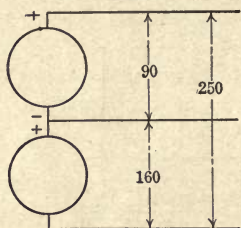

FIG. 131.—Multiple voltage system.

which is much cheaper than two single voltage machines each of half the output. This three-wire generator is described on page 317.

130. Ward Leonard System.—One method of obtaining a wide speed range, without the use of armature resistance, would be to use a separate generator with each adjustable speed motor and to vary the excitation of the generator so as to vary the voltage applied to the motor terminals. Such a system, shown diagrammatically in Fig. 132 is called the Ward Leonard System after its inventor. The outfit consists of a high-speed motor generator set supplied with each

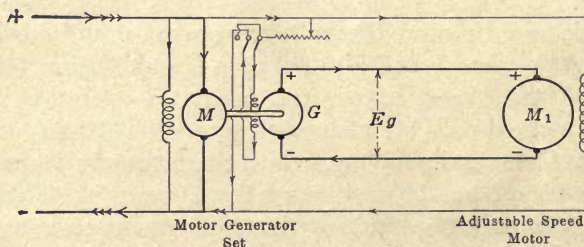

FIG. 132.—Ward Leonard system.

adjustable speed motor, the set consisting of a high-speed generator G direct connected to a motor M .

To obtain slow speeds, the field excitation of G is reduced so as to reduce the voltage E_g , which is applied to the motor M_1 . As the field excitation of G is increased, the voltage E_g increases.

and with it the speed of the motor M_1 . The motor M_1 can readily be reversed by reversing the excitation of G , so that the whole control is handled through a small field circuit rheostat and the efficiency is comparatively high.

The Ward Leonard system has been used for printing press work to obtain the very low speeds required when the paper is being fed into the machine, it has also been used to secure the delicate speed adjustment necessary for operating gun turrets in battleships. Because of the ease with which the motor M_1 can be reversed, this system has been used recently for the drive of large reversing planers, so as to eliminate the crossed belts.

131. Drive for Ventilating Fans.—For ventilating purposes it is necessary to control the volume of air delivered, to suit the requirements. This is done either by reducing the speed of the fan or by throttling the orifice.

When a fan is operated with a fixed orifice, the volume of air delivered is proportional to the speed, the pressure is proportional to the square of the speed, and the power required is proportional to the cube of the speed approximately.

When the volume of air is reduced by throttling the discharge, then the power taken is directly proportional to the volume delivered, the speed of the fan being constant.

For adjustable speed operation the shunt motor is used and, in the case of a fan drive, the speed reduction is obtained by the armature resistance method of control because of its simplicity; the total loss in the controlling resistance being small because of the large reduction in the load and therefore in the armature current as the speed drops. This may be seen from the following example, which is worked out by the same method as that on page 106:

The following data is taken from page 106:

The output is 10 h.p., 110 volts, 900 r.p.m. and the motor is shunt wound,

the armature resistance	= 0.08 ohms
the exciting current	= 2 amp.
the full-load armature current	= 75 amp.
the back e.m.f. at full-load and full speed	= 104 volts.

If the motor is driving a fan and the speed is reduced to 450 r.p.m. by inserting a resistance in the armature circuit, find the motor output, the armature current, the external resistance and the overall efficiency.

The horsepower output is proportional to the cube of the speed approximately and is therefore equal to $\frac{10}{2^3} = 1.25$ horsepower.

The torque = $\frac{\text{horsepower output} \times 33,000}{2\pi \text{ r.p.m.}}$ and is therefore equal to full-load torque $\times \frac{1.25 \text{ h.p.}}{10 \text{ h.p.}} \times \frac{900 \text{ r.p.m.}}{450 \text{ r.p.m.}} = 0.25$ times full-load torque.

The torque = $k\phi I_a$ and, since the flux ϕ is constant, therefore the current is proportional to the torque, so that the armature current is equal to 0.25 (full-load current) or 18.8 amp.

The back e.m.f. at half speed = $104/2 = 52$ volts, see page 106.

$$\begin{aligned} \text{The voltage applied to the motor} &= E_b + I_a R_a \\ &= 52 + (18.8 \times 0.08) \\ &= 53.5 \text{ volts} \end{aligned}$$

$$\begin{aligned} \text{The voltage drop across the external resistance} &= 110 - 53.5 \\ &= 56.5 \text{ volts.} \end{aligned}$$

the current in this resistance = 18.8 amp.

the resistance = $56.5/18.8 = 3$ ohms

the loss in the resistance = $56.5 \times 18.8 = 1060$ watts

the total input = $110 \times (18.8 + 2) = 2290$ watts

the motor output = 1.25 h.p. = $1.25 \times 746/1000 = 0.93$ kw.

the overall efficiency = $0.93/2.29 = 41$ per cent.

so that, although the overall efficiency is still low, the total loss in the control resistance is comparatively small.

132. Armature Resistance for Speed Reduction.—From the two problems on pages 106 and 111 it may be seen that the resistance required to reduce the speed to 50 per cent. of normal may be 0.7 ohms or 3 ohms, the corresponding losses in these resistances may be 3.9 kw. or 1.06 kw., and the currents 75 amp. or 18.8 amp., depending entirely on the kind of load.

If a rheostat built originally for constant torque duty is used with the same motor for fan operation, it will not have sufficient resistance to reduce the speed to the desired value; if a fan duty rheostat is used for constant torque service it will have to carry a larger current than it was designed for and will burn out. It is therefore very essential when specifying armature rheostats to specify the type of service for which it will be used.

133. Motors for Small Desk Fans.—These are usually series motors and are connected directly to the line without a starting resistance. When the current is switched on, the motor is at standstill and its back e.m.f. is zero, but the growth of the current in the machine is opposed by the self induction of the field and armature windings which are connected in series, while the inertia of the armature and fan are so small that the machine is up to speed before the current has time to reach a dangerous value. The load on a fan increases as the motor speeds up so that the motor cannot run away.

134. Printing presses must be run very slowly while being made ready, that is, while the web is being threaded, after which they must be smoothly accelerated to the desired running speed.

Large presses are equipped with two shunt motors, a main driving motor which is direct connected to the driving shaft, and an auxiliary starting motor which is connected to the driving shaft through a reduction gear and an automatic clutch.

While the press is being made ready, the auxiliary motor alone is connected to the power mains and drives the press at about 10 per cent. of normal speed. When the press is ready, the main motor is connected to the power circuit and is gradually accelerated, and, when the speed of the press has increased slightly above the make ready speed, the automatic clutch is released due to centrifugal force and the small motor is thereby disconnected mechanically from the press; it may then be disconnected from the power mains.

For small presses, the auxiliary starting motor is dispensed with, the make ready speed being obtained by inserting a resistance in the armature circuit. One objection to armature control is that the speed regulation is poor,

see page 107, and, when sufficient resistance is inserted to obtain 10 per cent. of normal speed, the regulation is very poor and the speed of the press is irregular. To obtain low speeds which are not irregular, the connection shown in Fig. 133 is used. If the current I_2 is large compared with I_a , then a considerable change in the value of I_a will have comparatively little effect on the total current I_1 so that the voltage e_r will not be greatly affected, the voltage E_a will therefore remain approximately constant and the speed regulation will be fairly good. The method is not economical since the current I_2 does no useful work but the larger the value of I_2 relative to I_a the better is the speed regulation. This method of control is used only where slow speeds are required for short intervals.

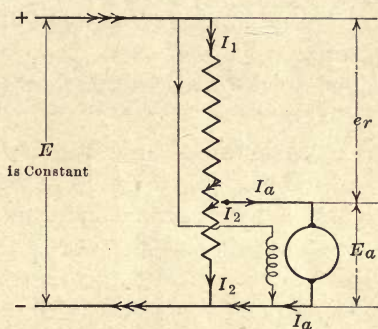

FIG. 133.—Connection for slow speed operation of shunt motors.

CHAPTER XIX

HAND-OPERATED FACE PLATE STARTERS AND CONTROLLERS

If a switch is opened in a circuit carrying current, an arc will be formed and, unless proper precautions are taken, the switch contacts will be burned.

135. Knife switches such as that shown in Fig. 143 are seldom used to open a circuit through which current is flowing; they are used to isolate a circuit after the current has been reduced to zero.

The quick-break switch shown in Fig. 134 has a main contact

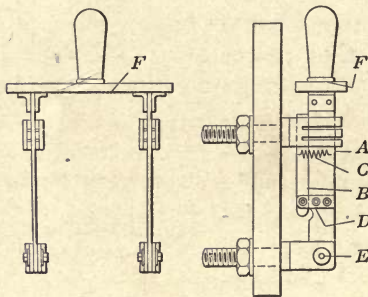

FIG. 134.—Quick break type of knife switch.

blade *A* and an auxiliary contact blade *B* held together by the spring *C*. When this switch is opened, the blade *B* is retained by friction until *A* has been withdrawn, the spring *C* then pulls out the blade *B* so quickly that no appreciable arc is formed. This quick-break principle in different forms is largely used when circuits carrying current have to be opened.

136. Auxiliary Carbon Contacts.—In the switch shown in Fig. 135, the main contact blocks *a* and *b* are bridged by an arch *c* of leaf copper, and an auxiliary carbon contact *d* is in parallel with the contact *a*. When this switch is opened, the contact *a* is the first to be broken, but the circuit is not interrupted since current can still pass through the contact *d*. This latter contact is broken

when the switch opens further, and an arc is formed which burns the carbon tips. Since these tips volatilize without melting, they remain in fairly good shape and, when badly burned, can readily be replaced; the carbon contacts have the additional

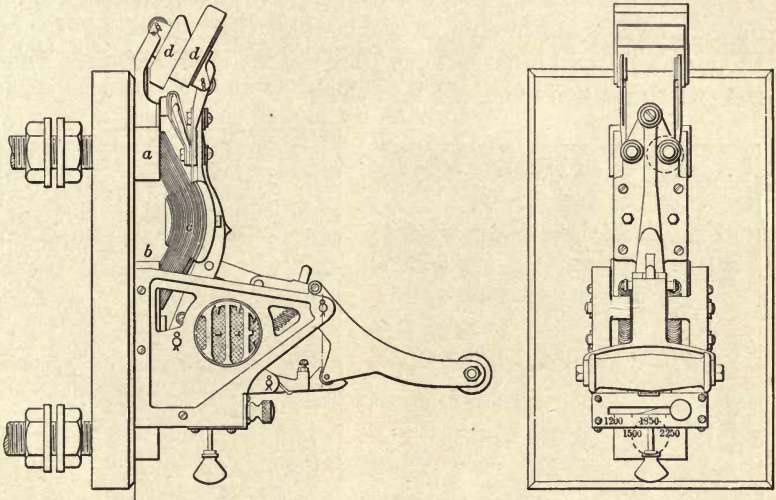

FIG. 135.—Circuit breaker with auxiliary carbon contacts.

advantage that by their means a comparatively high resistance is inserted in the circuit and the current is reduced before the circuit is broken.

137. Blow-out Coils.—If the conductor *ab*, Fig. 136, is carrying

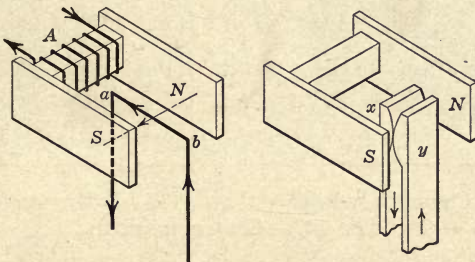
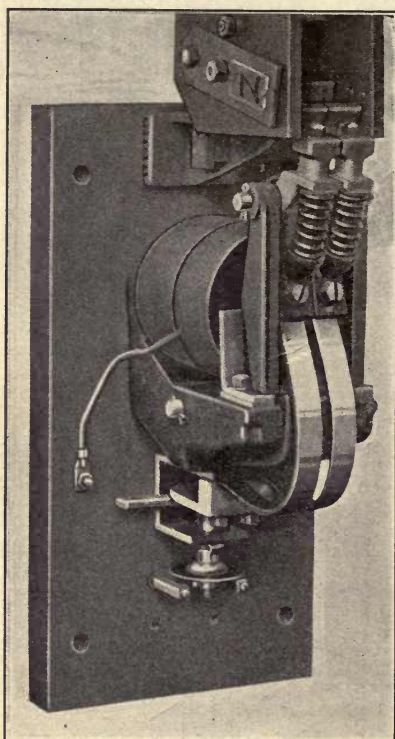

FIG. 136.—Principle of the blow-out coil.

current and is in the magnetic field *NS*, it is acted on by a force which, according to the left-hand rule, page 7, tends to move it upward. If *ab* is an arc formed between two contacts *x* and *y* as they are separated, this arc will be forced upward and will

lengthen and break. The coil *A* which produces the magnetic field is called the magnetic blow-out coil.

The application of this principle to a contactor switch is shown in Fig. 137. The blow-out coil *A* produces the magnetic field *NS*, so that if an arc passes between the switch contacts it will be forced upward and broken on the contact tips. The polarity of the magnetic field must be such that the arc is blown away from the switch contacts and not into them.



A Complete switch

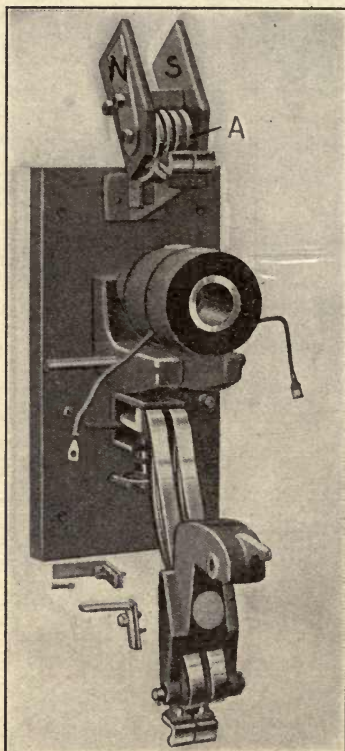

B Dismantled switch

FIG. 137.—Contactor switch.

138. Horn Gaps.—The intense heat of an arc causes convection currents of air to flow upward so that, if the switch jaws are shaped as shown in Fig. 138, the arc stream will be blown upward and will finally break between the arcing tips *c*, which tips may be removable.

This effect may be exaggerated by enclosing the contact in an

arc chute of such shape that the gases, expanding suddenly, can pass out only through the switch contacts. Such arc chutes, as for example that in diagram A, Fig. 137, when combined with magnetic blow-out coils, are very effective.

139. Fuses are used to protect electric circuits from overloads. A fuse is a piece of metal of such size and composition that it will melt and open the circuit when the current flowing becomes large enough to endanger the circuit.

The melting of a fuse is accompanied by an arc and by spattering of the fused metal so that it is generally advisable to mount the fuse in the center of a fiber tube and surround it with a fireproof powder to quench the arc, terminals being supplied as at *a*, Fig. 143, so that the fuse may readily be removed and replaced. A 10 amp. fuse is expected to carry 12.5 amp. continuously and 20 amp. for a period not greater than 2 minutes.

140. Circuit Breakers.—Circuits which are subject to frequent overloads are generally protected by automatic circuit breakers such as that shown in Fig. 135, rather than by fuses. The operation of such a circuit breaker has been described on page 40.

141. Motor Starters.—The requirements of a motor starter have been discussed on pages 85 and 87. These requirements have been met in many different ways but it is impossible in the space available to describe more than a few standard types.

142. The sliding contact type of starter, as used for shunt motors, is shown in Fig. 109. As the contact arm *A* is moved from the starting position A_1 to the running position A_2 the following operations are performed:

1. The field coils are fully excited as soon as contact is made with the first segment.
2. The starting resistance is gradually cut out as the contact arm is moved from A_1 to A_2 ; during this interval of time the motor should come up to speed.
3. The contact arm is held in the running position by the no-voltage release magnet *M*.

To stop the motor, the main switch is opened. This de-

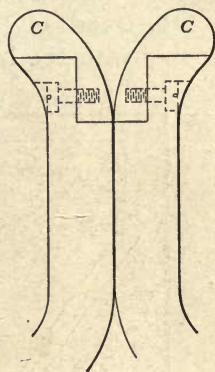

FIG. 138.—Removable horn tips for contactor switches.

energises the release coil M ; the contact arm is then pulled back to the starting position by the spring S .

143. Starting Resistance.—The resistance used with a starter must have sufficient current carrying capacity to allow the motor with which it is used to start up every 4 min. for an hour without overheating, the load being such that the motor shall come up to speed in less than 15 sec. with a starting current not greater than 1.5 times full-load current.

144. Overload Release.—The current in a shunt motor increases with the load and may damage the machine if the load

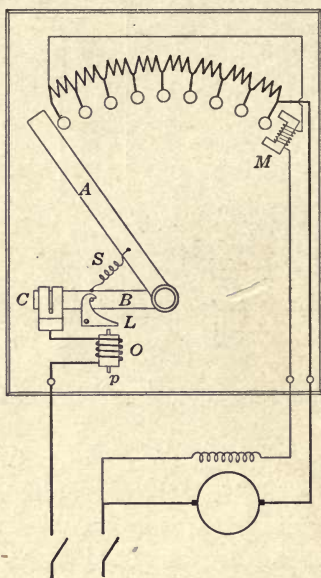

FIG. 139.

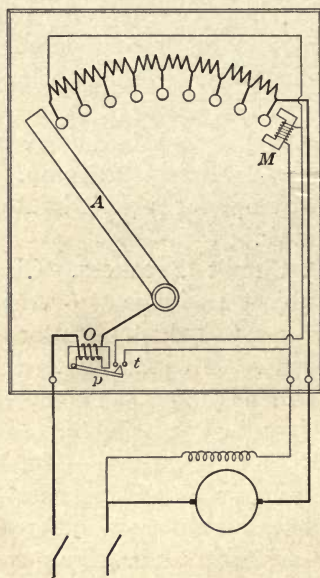

FIG. 140.

Starting boxes with both a no-voltage and an overload release.

becomes too large. To protect the motor, an overload release should be supplied to cut the machine out of operation as soon as the load becomes excessive. This overload release may take the form of fuses or of a circuit breaker, placed in the circuit as shown in Fig. 143, or it may consist of a special attachment on the starter as shown in Fig. 139.

In this type of starter the contact arm A performs the functions of a starting arm while the arm B , used to close the main circuit at C is connected to A by the spring S . To operate this starter,

the contact *C* is closed by the arm *B* and is held closed by the latch *L*, the arm *A* is then moved over the contact buttons so as to cut out the armature resistance, until it makes contact with the no-voltage release magnet *M* by which it is held against the tension of the spring *S*.

The latch *L* is released by the plunger *p* which is lifted when the line current passing round the solenoid *O* reaches a predetermined value; the arm *B* then flies up, opens the main circuit at *C* and at the same time deenergizes the magnet *M*. Before the motor can be started again the circuit must be closed at *C*; the spring *S* at the same time returns the contact arm *A* to the starting position thereby inserting the starting resistance in the armature circuit.

Another type of overload release is shown in Fig. 140. In this type, the motor current passes round the magnet *O* and,

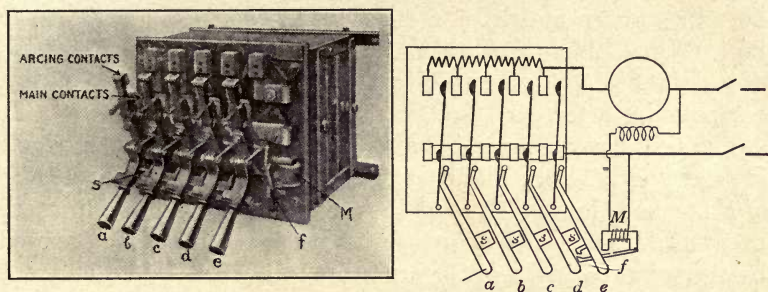

A Complete starter with resistance B Diagrammatic representation

FIG. 141.—Multiple switch type of starter.

when it reaches a predetermined value, the arm *p* is lifted to close the contacts *tt*, the no-voltage release coil *M* is thereby short circuited, the exciting current no longer passes around it, and a spiral spring in the hub brings the contact arm *A* back to the starting position and cuts the motor out of circuit. Such an overload release is shown on the starter in Fig. 143 and may be adjusted to open the circuit for any current up to 1.5 times full-load current. This type of release is cheaper than that in Fig. 139 but it has the disadvantage that it does not protect the motor during the starting period.

145. Multiple Switch Starters.—The sliding contact type of starter is liable to give trouble due to arcing at the contacts if used for motors larger than 35 h.p. at 110 volts or 50 h.p. at

220 to 500 volts; for such service the multiple switch type shown in Fig. 141 is to be preferred.

With this type of starter, each step of the armature resistance is cut out by a separate lever and the levers are so interlocked that they cannot be closed except in the proper order, thus switch *b* cannot be closed before *a* because of the stop *s*. Starting with *a*, the switches are closed hand over hand, each switch as it is closed keeping the one to the left of it in contact by means of the stops *s*; the last switch *e* is held closed by the latch *f*. Such a starter cannot be left partly closed with part of the resistance in circuit because none of the switches can stay closed until the last switch *e* is latched.

When the circuit is interrupted, the magnet *M* is deenergized, the latch *f* is released, and the switch *e* opens; the other switches then open one after the other.

146. Compound Starters.—The speed of a shunt motor may be adjusted by means of a rheostat in the field circuit (page 89). When this rheostat is incorporated in the starter, as shown in Fig. 142, the resulting piece of apparatus is called a compound starter.

The field contact arm *A* and the armature contact arm *B* are mounted on the same hub post; there is a spiral spring in the hub of *B* but none in *A*. To start the motor the two arms, which are interlocked, are moved over together, their motion being opposed by the spiral spring, and the armature resistance is gradually cut out by the arm *B* which finally makes contact with the no-voltage release magnet *M* by which it is held. The contact arm *A* is then free to move backward over the field contacts thereby weakening the shunt field and increasing the speed of the motor. During the operation of starting, the field resistance is short circuited by the switch *s* which is kept closed by a spiral spring in the hub *h*; this short circuit is removed while the starting arm *B* moves on to the last contact *c*, the switch *s* being then tripped by the projections *g*.

When the circuit is interrupted, the magnet *M* is deenergized, and the arm *B* is pulled back by the spiral spring in the hub and carries the field arm with it. With such a starter it is impossible to start up except with full field, it is also impossible to leave the starting arm *B* in any position intermediate between the starting and the running positions.

When a motor has to be operated with a weak magnetic field,

for adjustable speed operation, it is generally advisable to connect the no-voltage release coil *M* directly across the line so that its holding power is not weakened when resistance is put in the field coil circuit.

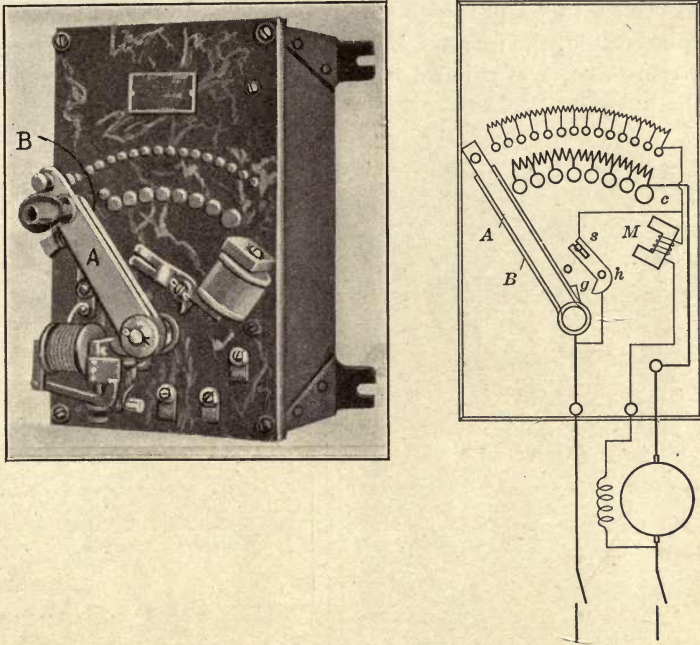

FIG. 142.—Compound starter.

147. Speed Regulators.—To obtain speeds lower than normal a resistance must be inserted in series with the armature, see page 89. Any of the starters already described can be used as a speed regulator if the resistance is able to carry the current of the machine continuously without overheating and if provision is made to return the contact arm to the starting position should the voltage fail.

A sliding contact type of speed regulator is shown in Fig. 143. Resistance in the armature circuit is used to cut down the speed below normal, while speeds higher than normal are obtained by inserting resistance in the field coil circuit on the steps between *c* and *d*.

This regulator operates in exactly the same way as a starter of the sliding contact type except that the handle can stay on any contact and can still be released from that contact by the no-

voltage release. Attached to the starting arm is the circular ratchet *C* which moves with the arm and, engaging in the ratchet from below, is a pawl which is caused to press against the ratchet by the no-voltage release magnet *M* and to notch into the ratchet when the contact arm is on a contact segment. Should the circuit be interrupted, the magnet *M* is deenergized, the pawl is released, and the starting arm is returned to the off position by a spring in the hub.

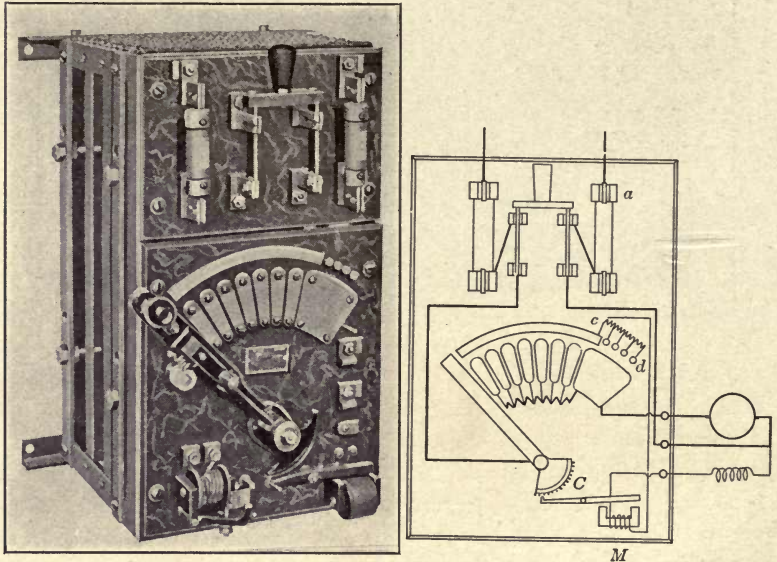

FIG. 143.—Sliding contact type of speed regulator.

148. Controllers for Series Motors.—Such motors are largely used for crane service and the controller used with them must be arranged to reverse the direction of rotation by reversing the armature connections and must also give speed regulation by means of resistance in the armature circuit.

A simple type of controller for this purpose is shown in Fig. 144. The path of the current through the controller is shown in diagram A when the motor is running in one direction and in diagram B when the direction is reversed.

The controller shown in Fig. 144 is supplied with a blow-out coil *A* which produces a magnetic field that passes from the front arms *B* to the back arms *C*, which arms are of iron. This magnetic field passes vertically through the slate front and so is at right

angles to the arc formed when a sliding contact leaves a segment, it therefore acts to blow out the arc.

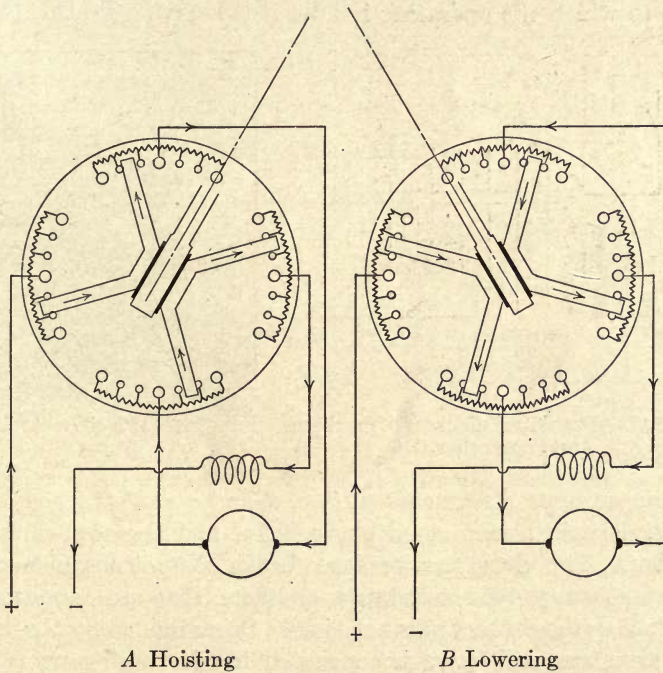
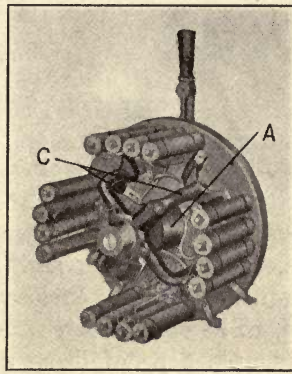
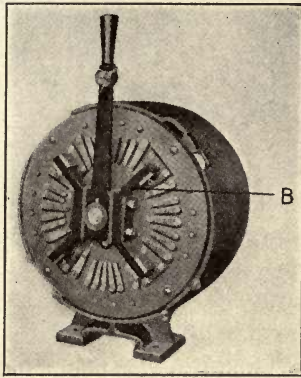

FIG. 144.—Face plate controller for a small reversing series motor.

The operation of crane and hoist motors is taken up in greater detail in Chapter XL.

CHAPTER XX

DRUM TYPE CONTROLLERS

149. Drum type controllers are particularly suited for adjustable speed motors which have to be started and stopped frequently, because the various operations are performed readily by the movement of a single handle and take place in their proper order. The controller is entirely enclosed and can readily be made weather-proof, while contact with the live parts is prevented.

A simple type of drum controller is shown in Fig. 146. It consists of a cast-iron drum cylinder *A*, insulated from a central shaft to which the operating handle *B* is keyed. To this drum,

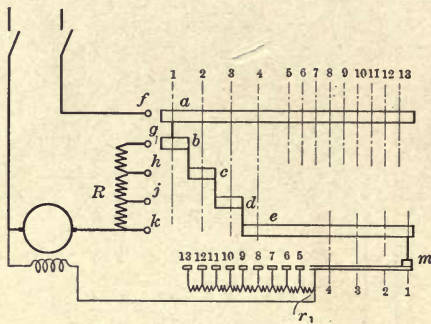

FIG. 145.—Developed diagram of machine tool controller.

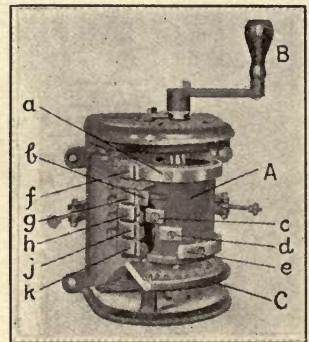

FIG. 146.—Machine tool controller.

the copper contact segments *a*, *b*, *c*, *d* and *e* are attached; these are in electrical contact with the drum and therefore with one another. The drum carries also a brush contact *m* which slides over stationary field resistance contacts that are mounted on the slate *C*; the contact *m* is not visible, being hidden by the drum. The armature resistance is connected to the stationary fingers *f*, *g*, *h*, *j* and *k* which are insulated from one another and mounted on a wooden base.

The action of such a controller may readily be understood from Fig. 145 which shows the controller drum developed on to

a plane; the vertical dotted lines indicate the successive positions of the contact drum with respect to the row of stationary fingers.

In position 1, the fingers *f* and *g* make contact with segments *a* and *b* of the drum, and the armature current passes through the whole armature resistance, while the field coils are fully excited, the exciting current passing through the contact *m*. In position 4, the armature resistance is all cut out but the field coils are still fully excited. In position 5, the brush *m* makes contact with field segment 5 and the resistance r_1 is inserted in the field coil circuit. With further motion of the drum from position 5 to position 13, the resistance in the field coil circuit is gradually increased, the magnetic field is weakened, and the speed of the motor is thereby increased above normal.

150. No-voltage and Overload Release.—The controller shown in Fig. 146 is not provided with either a no-voltage or an

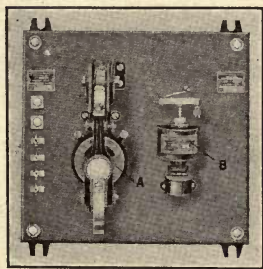

FIG. 147.—No-voltage and overload release panel.

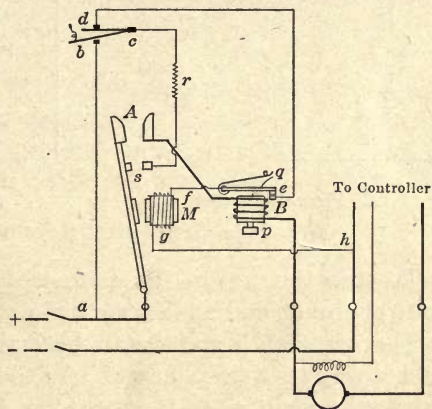

FIG. 148.—Connections of no-voltage and overload release panel.

overload release. These are sometimes incorporated in the controller but are more often supplied separately on a panel such as that shown in Fig. 147, the equipment consisting of a single pole magnetic switch *A* and an overload release coil *B*. The connections of this panel are shown diagrammatically in Fig. 148.

The contact *b* is kept open by means of a spring. When this contact is closed, current passes through the control circuit *abcdefgh*, from the positive to the negative side of the line, and

excites the electromagnet M , which closes the switch A and allows current to pass to the motor. When the switch A closes, the contact s also closes and current now passes through the circuit $ascdefgh$ and excites the magnet M , so that the contact b can be opened. In this latter circuit is a resistance r , which reduces the current in the holding coil M after the switch A has been closed so that this switch can open the more readily should power go off from the line; this magnetic switch A therefore acts as a no-voltage release.

The total current in the machine passes round the overload coil B and, when this current reaches a predetermined value, the plunger p is raised to strike the lever q and open the control circuit at e , thereby deenergizing the magnet M and allowing the switch A to open.

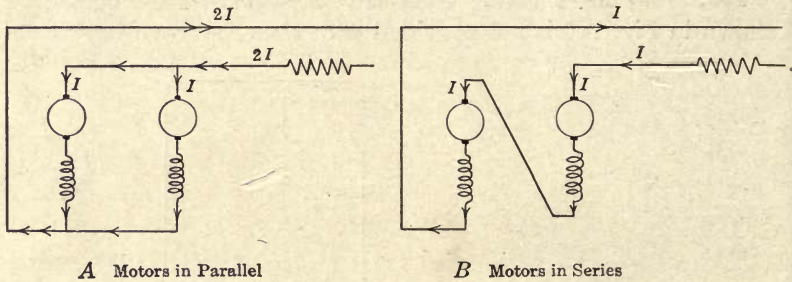

FIG. 149.—Series-parallel system of motor control.

To stop the motor, the contact d is opened; this opens the control circuit and allows the main switch A to open.

The contacts b and d can be embodied in the controller in such a way that the contact b and therefore the switch A cannot be closed except when the controller handle is in the off position and all the armature resistance is inserted in the armature circuit.

151. Street Car Controller for Series Parallel Control.—Street cars are equipped with series motors, and the number of motors per car is a multiple of two. To start these machines, a resistance is placed in series with the armatures as shown in diagram A, Fig. 149, and is then gradually cut out as the motors come up to speed.

The torque required to start and accelerate a car is much greater than that required to keep the car in motion so that the current I in the motor is large at starting and, if the motors are

connected as shown in diagram A, a large current $2I$ is taken from the line. To reduce this current for half of the starting period, the series parallel method of control is adopted.

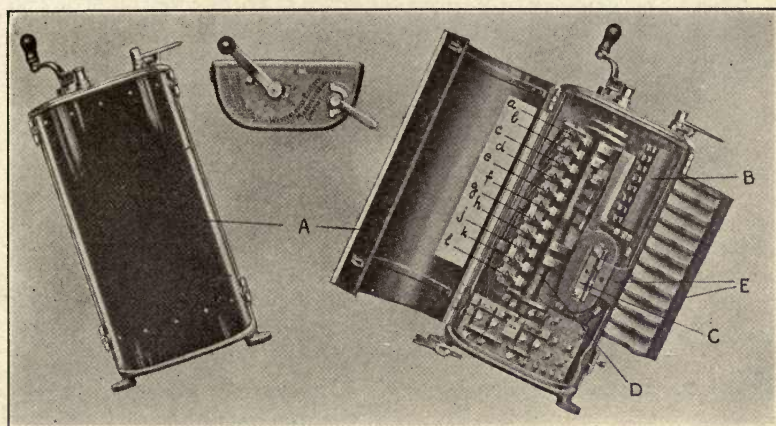

FIG. 150.—Street railway controller.

During the first half of the starting period, the motors are connected in series, as shown in diagram B, so that the total line current passes through both machines; when the starting resistance is all cut out, each motor has half of the normal voltage

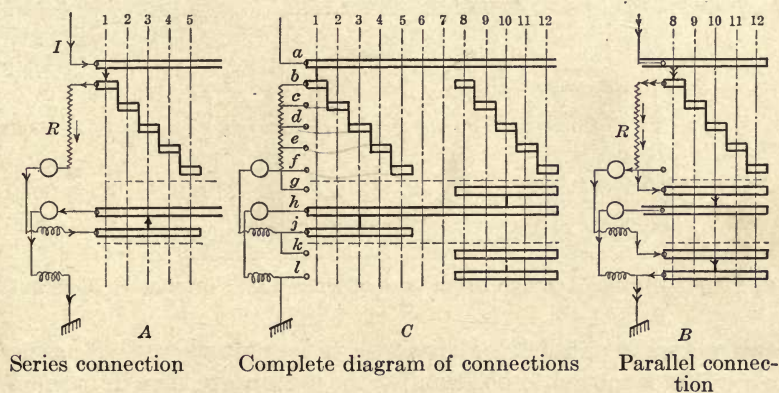

FIG. 151.—Diagram of connections of a street railway controller.

applied across its terminals and runs at half speed. To obtain higher speeds, the motors are now connected in parallel and the resistance is again inserted in the circuit as shown in diagram A;

this resistance is gradually cut out as the motors come up to speed and, when it is all cut out, each motor is running on normal line voltage.

These operations are performed with a drum controller of the type shown in Fig. 150, which controller is shown developed in Fig. 151.

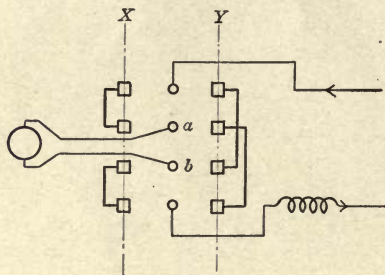

FIG. 152.—Diagram of connections of reversing drum.

The direction of the current when the controller is in position 1 is shown in diagram A. The current passes through the whole armature resistance R and then through the motors in series. The armature resistance is gradually cut out as the controller is moved to position 5, when the motors are in series across

the line and are running at half speed.

The direction of the current when the controller is in position 8 is shown in diagram B. The current passes through the whole armature resistance and then divides up and passes through the

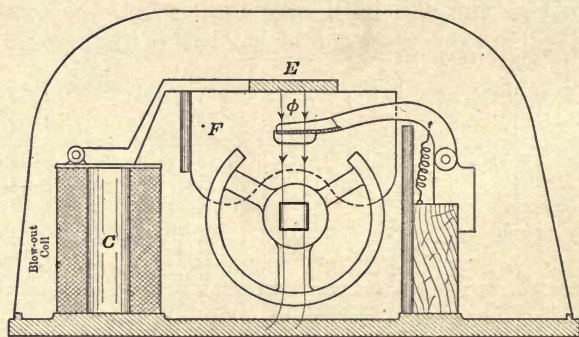

FIG. 153.—Section through drum type of controller, showing the blow out coil.

two motors in parallel. The resistance is gradually cut out as the controller is moved to position 12, the motors are then in parallel across the line and are running at full speed.

The complete controller is shown developed in diagram C. The student should draw the drum on tracing paper and move it over the stationary contacts and note how the various combinations are obtained.

152. Reversing Drum.—To reverse the motors, the armature connections are reversed relative to the field connections. This is done by means of the auxiliary drum B, Fig. 150, which is separate from the main drum but is so interlocked with it that the motors cannot be reversed except when the main drum is in the off position. This drum is shown developed in Fig. 152.

When the reversing drum is in position X, current passes through the armature from *a* to *b*; when in position Y, the current passes from *b* to *a*. A double set of such contacts are required for a pair of motors.

153. Mechanical Features of Drum Controllers.—The controller frame is of cast iron and has an asbestos lined removable cover A, Fig. 150; the back of the frame is pierced with a vertical row of holes lined with insulating bushings through which the necessary leads run.

The contact cylinder *D* with the copper contacts is supported by and insulated from a central shaft to which the operating handle is attached.

The blow-out coil is shown at *C*. Hinged to the case of the blow-out magnet is a steel plate *E* extending vertically the entire length of the cylinder and constituting such a magnetic circuit that a powerful magnetic field ϕ is maintained across the finger contacts as shown in Fig. 153. This steel plate is lined with asbestos on its inner side and carries moulded refractory insulating arc barriers *F* which project between the contact rings.

CHAPTER XXI

AUTOMATIC STARTERS AND CONTROLLERS

The tendency in the operation of electrical machinery is to make the starters and controllers self governing so that the machinery cannot be injured by careless or unskilled operators.

154. Automatic Solenoid Starter.—Fig. 154 shows a sliding contact type of starter in which the contact arm is moved by means of a solenoid. When the main switch *K* is closed, the solenoid *A* is excited and pulls the contact arm upward thereby cutting the resistance *R* out of the armature circuit; the rate at which the contact arm moves may be regulated by the dash pot *D*.

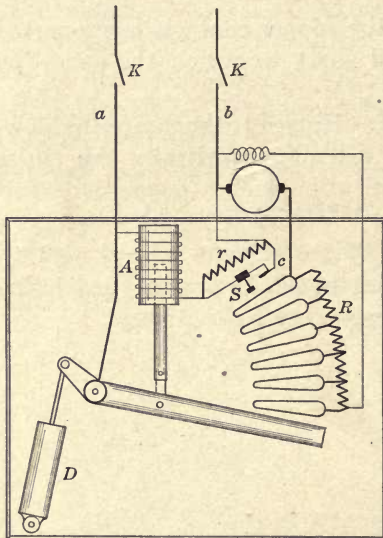

FIG. 154.—Automatic solenoid starter.

At the end of its travel the contact arm presses on the stop *s* and opens the contact *c* and thereby inserts the resistance *r* in the solenoid circuit so that the current in this circuit is reduced and is not larger than necessary to hold the arm in the running position. When the power is off, or when the switch *K* is opened, the solenoid is deenergized, and the starting arm falls by gravity to the starting position.

155. Float Switch Control.—With such an automatic starter it is not necessary to run the power mains to the point from which the motor has to be started. The main switch *K* may be magnetically operated and placed on the same panel as the starter as shown in Fig. 155. This switch is operated by a control circuit as shown diagrammatically in Fig. 156.

When the switch *s* is closed, the magnetic switch *K* is excited and closes the main circuit so that power is available at the motor

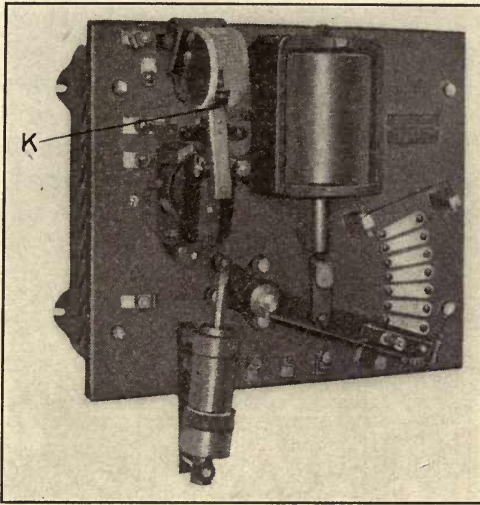

FIG. 155.—Automatic solenoid starter with main magnetic switch.

terminals. The switch *s* may readily be opened and closed by means of a float, a pressure gauge or some other device, so as to maintain the water level or the air pressure in a tank within prescribed limits.

When the float *F* in Fig. 156 falls below a certain point, the projection *e* raises the lever *l* and *W* is moved over. When *W* passes the vertical position it drops over and the projection *g* snaps the switch *s* into contact and closes the control circuit. When the water level reaches the upper limit, the projection *f* trips the lever *W* which opens the switch *s* and causes the motor to stop.

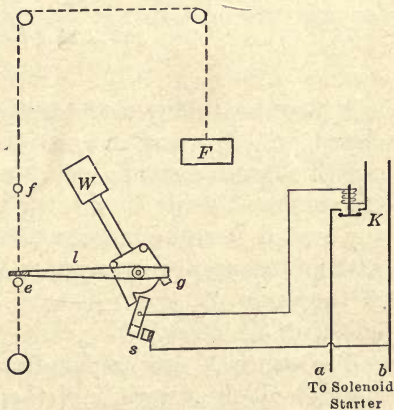

FIG. 156.—Float switch.

156. Magnetic Switch Controller.—Starters for large motors are of the multiple switch type, see page 119, and, when the

motors have to be operated from a distance, the switches are magnetically operated and are closed in their proper order by a master controller operating on a control circuit. Fig. 157 shows such a starter used to control a shunt motor by means of resistance in the armature circuit.

The switches *A*, *B*, *C*, *D*, *E* and *F* are magnetic contactor switches which close when the electromagnets *a*, *b*, *c*, *d*, *e* and *f* are excited. These magnets are connected across the mains *xy* in the proper order by means of a small drum controller *M* called a master controller.

As the drum *M* is turned, the first contacts to be made are *x* and 1 and the electromagnet *f* is excited and the main switch

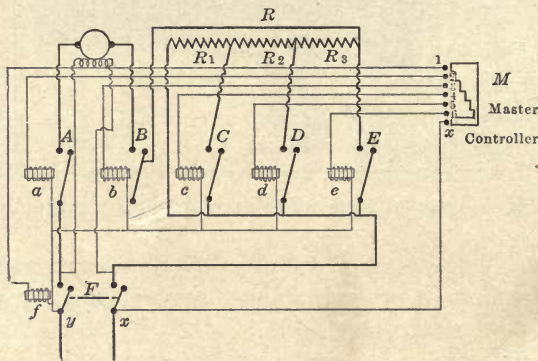

FIG. 157.—Magnetic switch controller.

F is closed. In the next position of the drum, the contact 2 is closed and the magnet *a* is thereby excited which closes the switch *A* and connects one terminal of the motor to the line. On contact 3 being closed, the magnet *b* is excited which closes the switch *B* and connects the motor armature across the line with all the armature resistance *R* in series. With further motion of the drum *M*, the resistances *R*₁, *R*₂ and *R*₃ may be cut out one after the other.

The drum *M* has to handle only the current in the control circuits which current is of the order of 1 amp., the drum may therefore be small in size.

With such a system of control, practically any series of operations can be performed in their proper order and several motors can be controlled from a single master controller.

157. Multiple Unit Control of Railway Motors.—The possibilities of magnetic switch controllers are well illustrated in the multiple unit system of car control. An electric train, made up of a number of cars each with its own motors and magnetic switch controller, can readily be controlled by a single operator at the head of the train.

The control circuit carries only a small current so that the leads are light and flexible; these leads are carried the whole length of the train. As each contact of the master controller is closed, the corresponding electromagnets under each car are excited and the switches closed. If for example, in Fig. 158, the contacts

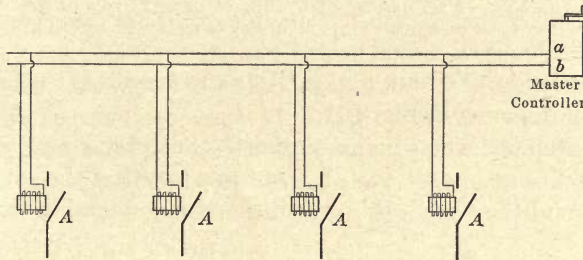

FIG. 158.—Principle of the multiple unit system of control.

a and *b* of the control circuit are energized by the master controller then the magnetic switches *A* on each of four separate cars will close simultaneously.

158. Automatic Magnetic Switch Starters.—With certain automatic features attached, the magnetic switch starter may be so constructed that the operator has only to close the main switch, after which the starting resistance is cut out automatically by the controller and the motor is brought up to speed without the starting current exceeding a predetermined value.

The operation of such automatic starters depends on the current changes in the armature circuit when the motor with which the starter is used is brought up to speed. In the hand operated starter in Fig. 159, when the switch *A* is closed, a current of about one and a half times full-load current flows through the armature and the starting resistance in series, and the motor starts up. As it gains in speed, the back e.m.f. increases and the current drops and, when this current has reached full-load value, the switch *B* is closed and the same current cycle is

again passed through. Fig. 160 shows the current cycle for a four switch starter such as that in Fig. 159.

In the automatic starter shown diagrammatically in Fig. 161, when the switch p is closed, the solenoid a is excited and the contractor switch A is closed thereby connecting one terminal of the motor to the positive side of the line and at the same time

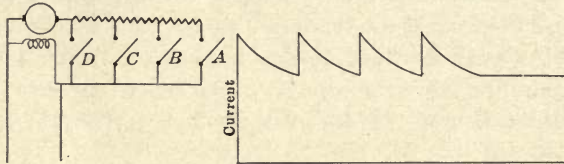

FIG. 159.—Multiple switch type of starter.

FIG. 160.—Current cycle in the armature circuit during starting.

closing the field coil circuit and exciting the machine; the field coil circuit is not shown in Fig. 161.

The switch A , when open, supports the relay e and when A closes e is dropped and closes the contacts f so that the solenoid b is excited and the switch B is closed thereby connecting the other

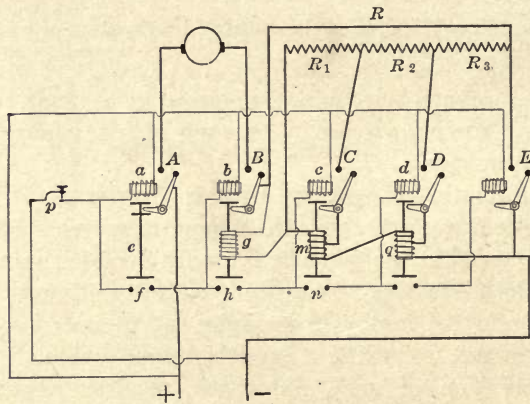

FIG. 161.—Automatic starter with shunt magnetic switches and series relays.

terminal of the motor to the negative side of the line with all the starting resistance in series. Current then passes through the armature, R_3, R_2, R_1, m and q .

When the switch B closes, a current of about one and a half times full-load current flows through the armature, and the motor starts up. Now the solenoid g is connected across the resistance

R , so that the voltage across this coil is the drop across the resistance, and the current which it sends through the coil is large enough to hold up the plunger g even although the mechanical support was removed when the switch B closed. As the motor gains in speed, its back e.m.f. increases and the drop across the resistance decreases so that the current in coil g decreases and, when this current has reached a predetermined value, the plunger of g drops and closes the contacts h , the solenoid c is thereby excited and the switch C is closed cutting out R_1 , the first step of the resistance.

After B closed but before c was excited, the motor current passed through the solenoid m and held up this plunger, but after the switch C has closed, this current passes through only the lower half of coil m . At the instant C closes, the current is large and although passing through only half of coil m it still holds the relay open. As the motor accelerates however, the current in the armature circuit decreases and finally reaches a value with which the solenoid m is no longer able to support its plunger, which plunger therefore drops and closes the contacts n , the solenoid d is thereby excited and the switch D is closed cutting out R_2 , the second step of the resistance.

The switch E operates in exactly the same way as D and cuts out the last step of the starting resistance. Such a relay switch as that used in this type of automatic starter is shown in Fig. 137.

159. Automatic Starter with Series Switches.—The closing electromagnets of the starter shown in Fig. 161 are shunt wound and the starter is said to be of the shunt switch type with series relays.

Another type of starter is shown in Fig. 163, the switches in this case carry the line current and are called series switches. They are so constructed that they will not close when the current flowing in the exciting coil exceeds a predetermined value. Such a switch is shown in Fig. 162. The upper end of the iron plunger E carries a non-magnetic stem G to which is attached a copper plate H which makes contact with the brushes k when the plunger is raised.

When a small current passes in the coil M , the flux in the magnetic circuit passes as shown in diagram A and the plunger tends to move upward so as to reduce the reluctance of the magnetic circuit.

When a large current passes in the coil, the flux in the magnetic

circuit passes as shown in diagram B; the reduced stem F becomes highly saturated so that a large part of the total flux passes across the gap l_2 without entering the stem and the plunger tends to move upward to reduce the gap l_1 and downward to reduce the gap l_2 . The larger the current, the larger the value of ϕ_2 relative to $\phi_1 + \phi_2$, and the less the tendency for the plunger to move up.

With such a solenoid then, when the current exceeds a pre-determined value, the downward pull plus the weight of the plunger keeps the plunger from being lifted, but as the current is decreased, the flux ϕ_2 and the downward pull both decrease

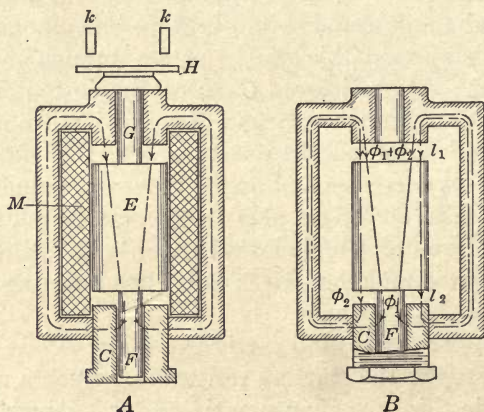

FIG. 162.—Series automatic switches.

rapidly as the stem F ceases to be saturated, until finally the upward pull is able to raise the plunger.

The critical value of current with which the plunger can be lifted may be adjusted by raising or lowering the iron plug C so as to change the value of ϕ_2 relative to that of $\phi_1 + \phi_2$.

A starter made with three such switches is shown in Fig. 163. When the switch A is closed, a large current flows through the armature, the starting resistance and the coil C_1 in series and the motor starts up; the switch g_1 however does not close until the motor has gained in speed and the current has dropped to the value for which the solenoid C_1 was set.

When C_1 closes, the first step of the starting resistance is cut out and the current, which increased considerably when the switch closed, now passes through C_1 and C_2 and the two remaining steps of the resistance. This current decreases as the

motor speeds up and then C_2 closes the contacts g_2 . The same current cycle is again passed through after which C_3 closes

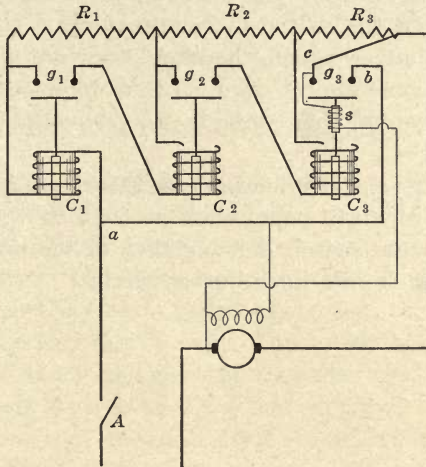

FIG. 163.—Automatic starter with series switches.

and cuts out the last step of the starting resistance. The contact g_3 is kept closed by means of the small shunt solenoid s .

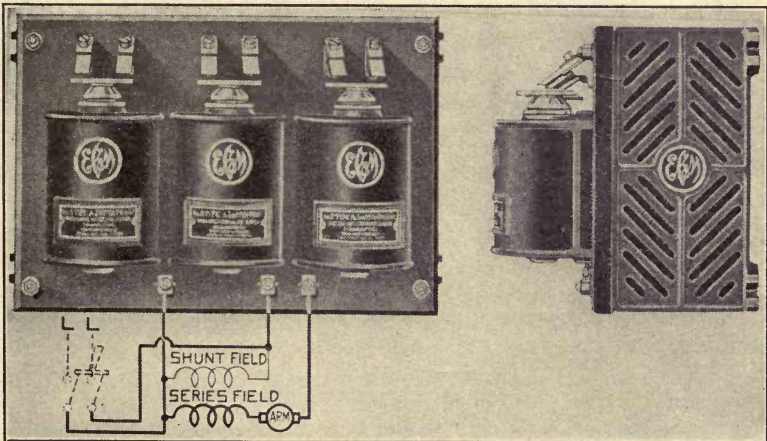

FIG. 164.—Automatic starter with three switches and with the starting resistance.

The contacts g_3 are the only ones that carry current continuously because, when C_3 closes, current no longer passes through

C_1 and C_2 because it has an easier path through the circuit abc , the plungers of C_1 and C_2 therefore drop.

When the main switch A is opened, the current in the motor circuit drops, but the switch C_3 requires only a small current to hold up the plunger which therefore does not drop until the current has become almost zero, so that blow-out coils are not required to protect the contacts g_3 . A complete starter is shown in Fig. 164.

The no-voltage and overload release attachments are generally supplied on a separate panel such as that shown in Fig. 147, page 125, the main switch A being then of the magnetic switch type is operated from a push-button circuit.

CHAPTER XXII

ELECTROLYSIS AND BATTERIES

160. Electrolysis.—Certain liquids conduct electricity but in doing so they undergo decomposition. Such liquids are called electrolytes and include bases, acids and salts, in solution or in the molten state. The conductors by which the current enters or leaves the electrolyte are called electrodes; that connected to the positive line terminal is called the anode and is the one at which the current enters, the other is called the kathode. The name electrolysis is given to the whole process.

It would seem that the electrolyte, in addition to containing complete molecules of the substance in solution, contains also molecules which are dissociated into ions (atoms carrying positive or negative charges) and that the metal and hydrogen atoms carry positive charges while non metals, the hydroxyl group (OH) and the acid radicals (SO_4 , NO_3 , etc.) carry negative charges. If then a difference of potential is established between the electrodes, the positively charged ions will be attracted to the negative electrode and the negatively charged ions to the positive electrode, where they give up their charges. When this occurs, the particle or group ceases to be an ion and displays at once its ordinary chemical properties.

If a direct current is passed through a solution of hydrochloric acid (HCl), using platinum electrodes, then the $+$ H ions will be attracted to the negative electrode where they will give up their charges and then appear as hydrogen gas, similarly the $-$ Cl will appear at the positive electrode.

If a solution of sulphuric acid (H_2SO_4) is used, then the $+$ H will be liberated at the negative electrode and the $-$ SO_4 at the positive electrode. The SO_4 , however, acts on the water of the solution to form sulphuric acid and oxygen, which latter gas is liberated while the acid goes into the solution. If the positive electrode had been of copper, then the SO_4 would have acted on the copper to form copper sulphate which would have gone into the solution.

161. Voltmeter.—If a negative electrode of platinum and a positive electrode of pure silver are used in a solution of silver nitrate (Ag NO_3), then silver is deposited on the negative plati-

num electrode and the $-NO_3$ acid radical, liberated at the positive electrode, acts on the silver to form more silver nitrate, which goes into solution and thereby keeps the concentration of the electrolyte constant.

Faraday's experiments showed that the mass of material deposited is proportional to the quantity of electricity (current \times time) so that the apparatus described above, called the silver voltameter, can be used as a measure of quantity of electricity. This instrument is used as a primary standard.

162. Electric Battery.—An electric battery is a device for transforming chemical energy into electrical energy and consists essentially of two dissimilar plates in a solution which acts more readily on one plate than on the other. A difference of potential is found between two such plates so that if they are joined by a wire an electric current will flow in this wire. The magnitude of this e.m.f. depends only on the material of the plates and on the electrolyte and, for a given pair of plates, is independent of their area.

There are innumerable types of battery, but in nearly every case one plate is of zinc and the other of either carbon or copper. If a battery is made of copper, zinc and dilute sulphuric acid, it will be found that, when current flows in a conducting wire connecting the copper and the zinc plates, the zinc goes into solution as $ZnSO_4$ while hydrogen is given off at the copper plate. The zinc and the sulphuric acid are therefore used up and electrical energy is obtained at the expense of the chemical energy which was contained in these materials.

When the cell becomes exhausted, the zinc plate and the electrolyte have to be renewed. When fresh materials are used, the battery is called a primary battery; when the materials are renewed by electrolysis in a way that shall be described later, the battery is called a secondary or storage battery.

163. Theory of Battery Operation.—If we consider a battery made up of copper, zinc and dilute sulphuric acid, then the essential difference between these metals so far as battery operation is concerned is that the zinc is the more readily acted on by oxygen or has the greater chemical attraction for oxygen so that, while both copper and zinc attract the $-O$ ions in the solution, the attraction of the zinc is the greater. As both metals combine with the attracted oxygen they become negatively charged and soon repel the negative oxygen ions as strongly electrically as

they attract them chemically. When equilibrium is established, both metals are negatively charged but the negative charge on the zinc is the greater and its potential is therefore the lower. If the two metals are now joined by a connecting wire outside of the solution, electricity flows from the copper to the zinc and the plates tend to come to the same potential, so that the state of equilibrium is disturbed; the potential of the zinc rises slightly above its potential of equilibrium so that it is able to attract more negative oxygen, while the potential of the copper falls slightly below its potential of equilibrium so that it now attracts the positive hydrogen ions, the voltage between the plates is therefore maintained and so also is the current in the conducting wire.

The zinc oxide formed is acted on by the sulphuric acid to form zinc sulphate which goes into the solution and is no longer an active constituent of the cell.

164. Polarization.—The action of this battery weakens after a few minutes of operation, and this weakening is found to be due to a layer of hydrogen bubbles which cling to the copper plate after giving up their charge. The cell is then one which has active plates of hydrogen and zinc and gives a much lower e.m.f. than one of copper and zinc. Hydrogen has also a high electrical resistance so that the current that can be drawn is small. This defect of the battery is called polarization, and different methods are used to keep the hydrogen bubbles away from the copper plate, generally by the use of a depolarizing substance containing an excess of oxygen, which substance is placed around the copper plate.

165. The E.M.F. and Resistance of Cells.—The electromotive force depends only on the materials of the cell and is independent of their size, shape or arrangement.

The internal resistance of a cell of given materials is proportional to the distance between the plates and inversely proportional to their area and, in order that a cell may have a low internal resistance, the plates should have a large surface and should be close together.

166. The Daniell cell is a commercial type of copper, zinc and sulphuric acid battery largely used for telegraph work. The depolarizing substance in this cell is copper sulphate (CuSO_4). In one form of this battery the sulphuric acid with the zinc are placed in a porous pot and this in turn is placed in a saturated

solution of copper sulphate contained in a glass jar, the copper plate is immersed in this latter solution. By means of the porous pot the liquids are kept from mixing but the action of the battery is not impaired since the ions pass freely through the walls of the pot.

The hydrogen liberated at the copper electrode acts on the adjoining copper sulphate to form copper and sulphuric acid; the copper is deposited on the electrode so that there is no hydrogen layer formed and therefore no polarization of the cell until all the copper sulphate in the solution has been exhausted.

The usual size of Daniell cell has a voltage on open circuit of about 1.1 and an internal resistance of about 2 ohms so the largest current that can be obtained from such a cell is 0.55 amperes on short circuit.

167. Calculation of the E.M.F. of a Daniell Cell.—Faraday's experiments showed that, when electrolysis takes place, the number of gm. of substance separated out per coulomb is equal to $\frac{\text{atomic weight}}{96,540 \times \text{valency}}$, or the coulombs required to produce a number of grams equal to the atomic weight is $96,540 \times \text{the valency}$.

Copper (Cu) and zinc (Zn) have a valency of two in compounds such as CuSO_4 and ZnSO_4 , because one atom of Cu or Zn replaces two atoms of H from H_2SO_4 , and, since the atomic weight of Cu is 63.75 and that of Zn is 65.37 therefore $96,540 \times 2$ coulombs will separate out 63.75 gm. of Cu from CuSO_4 and 65.37 gm. of Zn from ZnSO_4 .

When 63.75 gm. of Cu are formed into CuSO_4 , 197,500 gm. calories of energy are liberated and when 65.37 gm. of Zn are formed into ZnSO_4 , the energy liberated is 248,000 gm. calories.

In a Daniell cell then, when 65.37 gm. of Zn have been consumed, $96,540 \times 2$ coulombs have passed and 63.75 gm. of Cu have been separated out from the CuSO_4 , the energy given up by the cell must therefore be

$$\begin{aligned} 248,000 - 197,500 &= 50,500 \text{ gm. calories} \\ &= 50,500 \times 4.186 \text{ watt sec. see page 15} \\ &= 211,400 \text{ watt sec.} \end{aligned}$$

$$\begin{aligned} \text{and } 96,540 \times 2 \times \text{voltage of cell} &= \text{energy obtained} \\ &= 211,400 \text{ watt sec.} \end{aligned}$$

from which the voltage of the cell = $\frac{211,400}{96,540 \times 2} = 1.1$ volts
assuming that no energy was lost in the form of heat.

168. Local Action.—In a well-designed and constructed cell, action takes place only when the cell is delivering energy. Commercial zinc, however, dissolves in sulphuric acid even when the external circuit is not closed because the zinc is impure and local action is set up between the impurities and the zinc and a number of small internal batteries are formed in which the zinc is consumed but no voltage is available at the terminals. To prevent this action the zinc is amalgamated, that is covered with a layer of mercury. To amalgamate zinc, clean it with sandpaper, then immerse in dilute sulphuric acid and while still wet apply mercury to it with a rag. So far as the action of the battery is concerned the mercury is inert.

169. Leclanché Cell.—This battery consists of carbon (C) and Zinc (Zn) in ammonium chloride (NH_4Cl). The zinc is converted into zinc chloride (Zn Cl) while ammonia (NH_3) and hydrogen (H) appear at the carbon plate. To prevent polarization, the carbon is surrounded with an oxidizing agent in the form of manganese dioxide (MnO_2), the oxygen of which attacks the hydrogen to form water. In the usual form the carbon is placed in a porous pot and is surrounded with granules of manganese dioxide and of carbon. The action of this depolarizer is slow so that, when used to supply current for a considerable time, the cell becomes polarized and runs down; it will recover, however, if left on open circuit.

The battery gives a voltage of about 1.5 on open circuit and has an internal resistance of about 1.5 ohms. It is much used for bell ringing and other intermittent work and requires little attention beyond the addition of water as the solution evaporates, and the renewal of the zinc as it is used up. The zinc generally supplied is not amalgamated, and non-conducting crystals of ZnCl stick to its surface instead of dropping to the bottom; the operation is improved if amalgamated zinc is used.

170. Dry Cells.—These are largely used when the battery is subject to motion, as in motor cars and motor boats. There are innumerable types but nearly all consist of carbon, zinc and sal ammoniac with other ingredients, in fact they are Leclanché cells. The form usually taken consists of an outer cell of zinc which is one electrode and is lined with blotting paper. The carbon stick is placed in the center and is surrounded with a mixture of manganese dioxide and powdered carbon. The blotting paper and the powdered mixture are saturated with the electrolyte and

a layer of sawdust is placed on the top after which the cell is sealed with pitch. The outside is then wrapped with paper so as to insulate the zinc. The current depends on the size of the cell, the usual size, 2.5 in. dia. and 6 in. high, will give about 15 amperes on short circuit for a few seconds.

Such cells deteriorate in storage, to prevent which one type has a hollow carbon rod with a stopper; it is shipped dry and so is chemically inactive until ready for use when it is filled with water through the hole in the carbon.

These cells run down as the active materials are consumed but may often be recuperated temporarily by the addition of sal ammoniac to the blotting paper through a hole made in the pitch, even water will help in an emergency.

171. Edison Lalande Cell.—The active materials in this cell are copper oxide (CuO) and zinc in a solution of caustic potash KOH . The oxygen ions combine with the zinc to form zinc oxide and this combines with the potash to form a soluble salt. The hydrogen reduces the copper oxide to metallic copper and so does not polarize the cell. The construction is very rigid. The positive plate of CuO and the negative Zn plate are separated by porcelain spacers and rigidly fastened to the top of the containing jar which jar is of enameled steel. A layer of mineral oil is placed on the top of the electrolyte to keep out the air and to prevent the formation of creeping salts.

The internal resistance of this cell is low so that large currents can be drawn from it; thus a 600 ampere-hour battery has an open-circuit voltage of 0.95 and an internal resistance of about 0.02 ohm; this battery is designed to deliver 7 amp. for 85 hours although the battery would give over 40 amp. on short circuit.

172. Power and Energy of a Battery—The active materials in a battery contain a definite quantity of chemical energy which may be transformed into electrical energy, so that a battery can give a definite number of watt-hours or a definite number of ampere-hours at normal voltage.

This energy may be taken as a small current for a long time or a large current for a short time so that while the total energy in the battery is fixed by the weight of the active materials the power of the battery (volts \times amp.) may vary over a wide range.

173. Battery Connections.—If E_o is the open-circuit voltage of a battery, R_b is the internal resistance and R is the resistance

of the external circuit then the current $I = \frac{E_o}{R_b + R}$ and has a maximum value on short circuit $= \frac{E_o}{R_b}$.

If n batteries are connected in series, then the current $I = \frac{nE_o}{nR_b + R}$ and an increase in the number of batteries does not produce any considerable increase in the current unless R is large compared with R_b .

If n batteries are connected in parallel, then the current $I = \frac{E_o}{R_b/n + R}$ and an increase in the number of batteries does not produce any considerable increase in the current unless R is small compared with R_b .

The internal resistance of a Daniell cell is 2 ohms and the no-load voltage is 1.1 volts. The current when the batteries are connected in series and in parallel is given in the following table (a) when the external resistance is 10 ohms and is greater than that of the battery; (b) when the external resistance is 1 ohm and is less than that of the battery:

Number of cells	Total resistance of cells	External resistance	Amperes	Terminal voltage	
				Open circuit	With current
(a)	2 ohms	10 ohms	0.092	1.1	0.92
10 in series	20 ohms	10 ohms	0.365	11.0	3.65
10 in parallel	0.2 ohm	10 ohms	0.108	1.1	1.08
(b)	2 ohms	1 ohm	0.365	1.1	0.365
10 in series	20 ohms	1 ohm	0.52	11.0	0.52
10 in parallel	0.2 ohm	1 ohm	0.92	1.1	0.92

CHAPTER XXIII

STORAGE BATTERIES

174. Action of the Lead Cell.—If a plate of lead peroxide (PbO_2) and one of lead (Pb) are placed in a solution of sulphuric acid (H_2SO_4) a battery is formed with the peroxide plate at the higher potential. The generally accepted theory of operation is as follows:

The sulphuric acid acts on the lead plate to form lead sulphate, which material stays on the plate

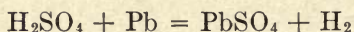

The hydrogen ions have their charge neutralized at the peroxide plate which they reduce to lead monoxide



The lead monoxide thus formed is acted on by the acid to form lead sulphate, which material stays on the plate

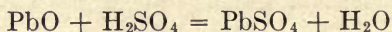

The final result may therefore be represented by the equation

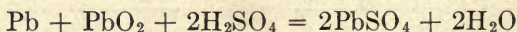

so that, during discharge, sulphuric acid is taken from the electrolyte, water is added to it, and the specific gravity of the electrolyte is thereby decreased, while both plates are converted into lead sulphate.

If now current from some external source is forced through the cell in the opposite direction so as to cause electrolysis, the action is completely reversed:

The positive H ions of the acid are attracted to the negative PbSO_4 and reduce it to lead



The negative SO_4 ions of the acid are attracted to the positive

PbSO₄ and, being liberated there, act on the water of the solution to form sulphuric acid and oxygen

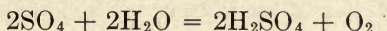

This oxygen, with more water from the electrolyte, act on the sulphate plate to form peroxide of lead and sulphuric acid

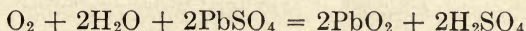

The final result may therefore be represented by the equation

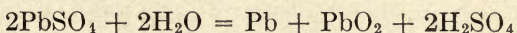

so that during charge the plates are reformed while sulphuric acid is added to the electrolyte, water is taken from it, and the specific gravity of the electrolyte is thereby increased.

After the plates have been completely reformed, further charging will cause the hydrogen and oxygen to appear as gases which bubble up through the electrolyte from the surfaces of the plates, the cell is then said to be gassing.

175. Storage or Secondary Battery.—An electric battery which can be reformed by chemical means is called a storage or secondary battery. There is no essential difference between a primary and a secondary battery. In the former the active materials themselves are renewed when the cell is exhausted, whereas the latter is designed to permit of the materials being brought back to their original state by electrolysis, that this may be possible, no product formed during discharge must be lost.

176. Sulphation.—There would appear to be two forms of lead sulphate, an unstable electrolytic form which is readily reduced by an electric current, and the lead sulphate formed by chemical precipitation which latter is a non-conducting substance not decomposed by an electric current. This latter substance must not be allowed to accumulate on the plates.

The electrolytic form changes slowly into the insoluble form and for that reason a lead battery must not be left discharged for any length of time; insoluble sulphate also tends to form if the battery is discharged too far.

The formation of this insoluble sulphate is called sulphation and must be prevented by proper operation of the battery. If sulphation has commenced on some of the plates and has not gone too far, the plates may be cleared by overcharging the

battery for a long time, the hydrogen and oxygen formed when the cell is overcharged tear off the insoluble sulphate.

177. Construction of the Plates.—When fully charged, the positive plates are chocolate in color and the peroxide is hard while the negative plates are gray in color and the spongy lead is so soft that it can be scraped off with the finger nail. During discharge, these plates are converted into lead sulphate, which is bulky, so that the plates expand and, unless carefully designed, are liable to buckle, especially if the cell is discharged rapidly so that the

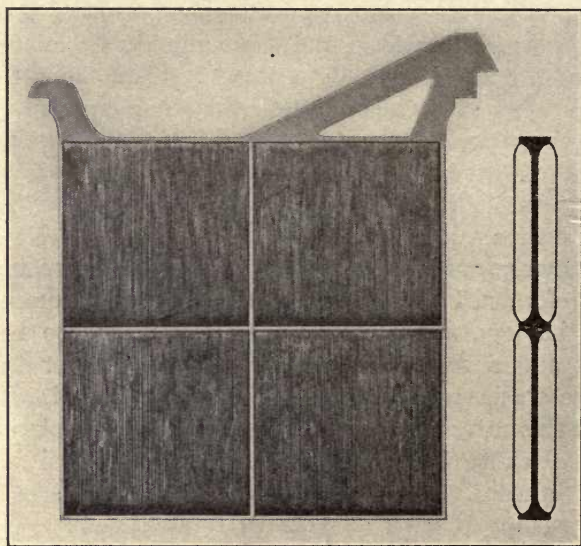

FIG. 165.—Planté plate, showing cross section.

sulphate is formed rapidly and loosely. The negative plate in addition must be so designed that the soft material will not be readily washed off.

There are two ways of forming the active material. By the Planté process the material is formed electrochemically out of the lead plate itself, the plates being grooved or made in the form of a grill so as to have a large exposed surface. The plates shown in Fig. 165 are made out of pure rolled lead passed backward and forward through grooving rolls which spin the lead into ribs the pitch of which is made to suit the service. The peroxide and spongy lead, formed electrochemically on the positive and nega-

tive plates respectively, pack into the grooves and are tightly held in the narrow spaces.

Pasted plates are made by spreading a paste of the active material on to a supporting grid of lead hardened with a small quantity of antimony, this being the only commercially available material which will resist the action of sulphuric acid and will not set up local action with either the spongy lead or with the peroxide. Most of the processes by which these plates are prepared are secret, but by such processes plates can be made soft and porous or hard and dense according to the service for which they are required.

Planté plates are used largely for stationary batteries; they are heavier and more costly than pasted plates but are also more

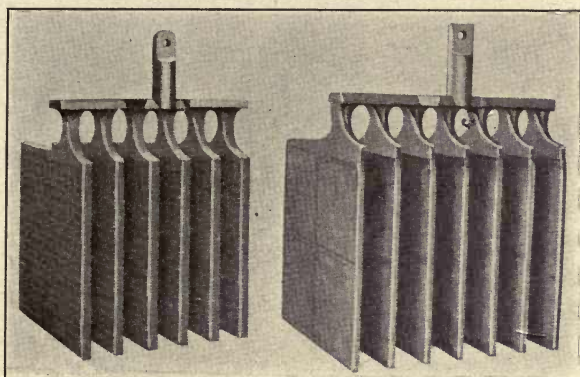

Positive group Negative group.
FIG. 166.—Groups of plates for a lead battery.

durable and less liable to lose active material by rapid charging and discharging. For automobile and motor truck service, pasted plates are generally used because they are lighter than Planté plates.

178. Construction of a Lead Battery.—To obtain large capacity from a battery, a large surface must be exposed to the electrolyte, and, since the size of a single plate is limited, increased capacity must be obtained by connecting a number of plates in parallel to form a group as shown in Fig. 166, there being one more plate in the negative than in the positive group. Two sets of plates are then sandwiched together, adjoining plates being separated from one another by glass rods in the case of large power-house cells or

by wooden and rubber separators in smaller cells. The wooden separators, see Fig. 167, are specially treated and are grooved vertically to allow the gases and the electrolyte to circulate freely; the flat side is placed against the soft negative plate while between the positive plate and the corrugations on the wood a sheet of perforated hard rubber is placed, as shown in Fig 167, which helps to prevent washing out of the active material.

The plate groups are placed in an acid-proof tank, generally of glass, hard rubber, or of wood lined with lead, and are sup-

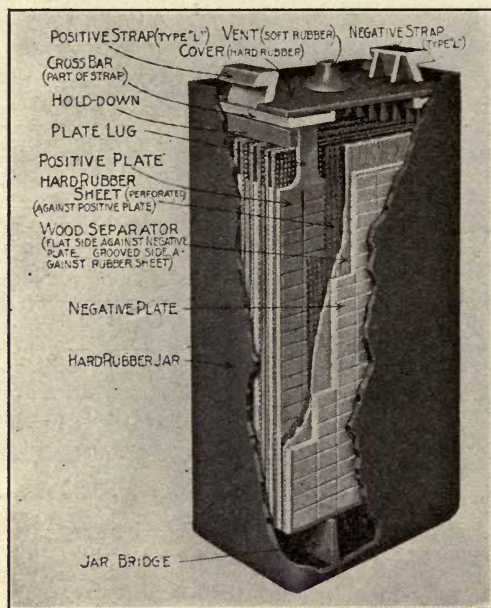

FIG. 167.—Portable type of lead battery.

ported in various ways as shown in Figs. 168 and 169, ample space being left below the plates for the accumulation of sediment which must not be allowed to short circuit the plates.

To minimize leakage of electricity, the tanks are insulated from one another. Small cells are generally carried on shallow trays filled with sand and supported on glass insulators as shown in Fig. 168. Large lead-lined tanks are generally mounted as shown in Fig. 169 with a double set of insulators between the tank and the ground.

To prevent loss of electrolyte due to spraying when the cells are gassing freely, glass sheets are placed over the tanks.

For automobile work, hard rubber jars are used. These are placed in a wooden box and compound is poured around the jars and flooded over the top so as to hold them securely and also to seal the battery and thereby prevent loss of electrolyte. To provide for the escape of the gases generated during over-charge, vents are provided, constructed so as to allow the gases to escape but prevent the escape of the electrolyte.

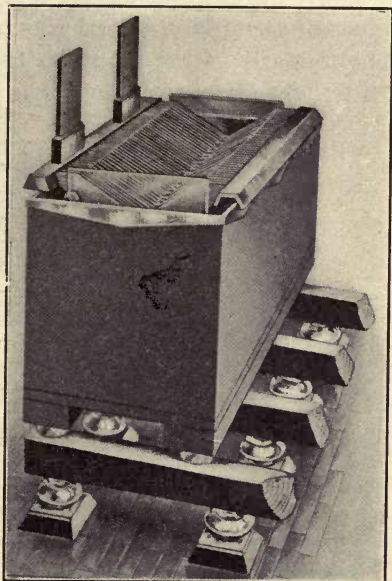
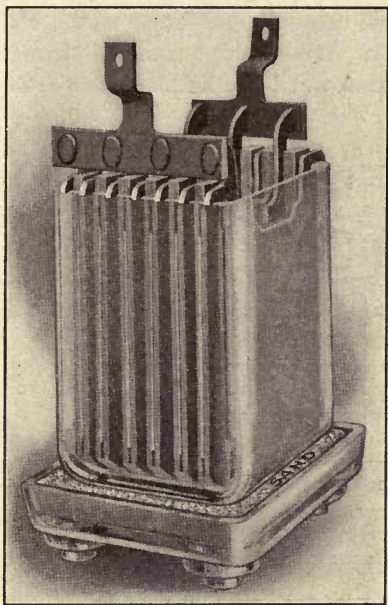

FIG. 168.—Small cell in a glass jar supported on sand.

FIG. 169.—Central station type of lead cell.

179. Voltage of a Lead Battery.—The terminal voltage of a battery

$$= E_b + IR \text{ while the battery is charging}$$

$$= E_b - IR \text{ while the battery is discharging}$$

where E_b is the internal generated voltage of the battery

I is the current in amperes

R is the effective internal resistance in ohms

so that the larger the current the greater the difference between the charge and discharge voltages.

The value of E_b , the generated voltage, depends on the strength of the electrolyte and increases slightly as the acid becomes stronger, it therefore increases during charge and decreases during discharge.

The internal resistance of the cell depends on the specific gravity of the electrolyte and is a minimum when this has a value of about 1.22, which is about the normal value used in cells. During discharge the acid becomes weak, particularly in the pores where the action is taking place, and sulphate is formed which is a comparatively poor conductor of electricity, so that, towards the end of discharge, the internal resistance of the cell increases rapidly. During charge the acid becomes strong, particularly in the pores, so that toward the end of charge the internal resistance again rises.

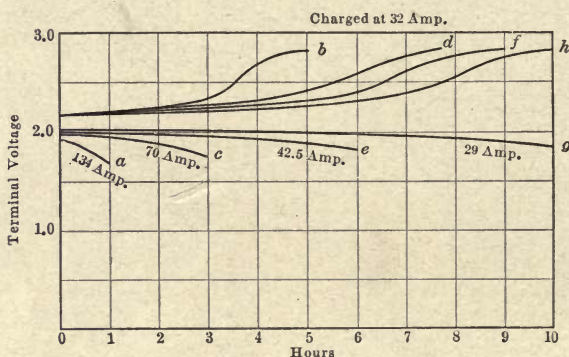

FIG. 170.¹—Charge and discharge curves of the same lead cell at different discharge rates.

The curves in Fig. 170 show how the voltage varies during charge and discharge, the charge being continued until the voltage and the specific gravity have become constant and the active materials therefore completely formed, while the discharge is stopped when the terminal voltage has dropped to about 1.8, the safe minimum value at the normal discharge rate. If the discharge is carried much further than this it becomes difficult to clear the plates of sulphate on re-charging.

The ratio $\frac{\text{average voltage on discharge}}{\text{average voltage on charge}} = \frac{E_b - IR}{E_b + IR}$ is called the volt efficiency and is lower the larger the current I , that is, the higher the rate of charge and discharge. At the normal rates of

¹Secondary cells by Aspinall Parr; Journal of the Inst. of Elect. Eng., vol. 36, p. 406; sec. 1905.

charge and discharge this efficiency is seldom less than 80 per cent.

180. Capacity of a Cell.—The current that can be drawn from a cell depends on the plate surface exposed to the electrolyte, on the porosity of the plates, and on the rate of discharge. An excessive current is liable to buckle the plates, see page 148, while a short circuit will cause such violent action and such a sudden evolution of gas in the body of the active material as to cause parts of this material to be ejected from the plates.

The capacity of a battery is given in ampere-hours at a definite rate of charge and discharge, generally an 8-hour rate, except in the case of automobile batteries which are generally rated at a 4-hour rate as this more nearly corresponds to the actual service conditions. A battery with a rating of 100 amp.-hours will deliver 12.5 amp. for 8 hours before the voltage drops below 1.8. Theoretically this same battery, after being fully charged, should give the same total quantity of electricity at all rates of discharge, that is, it should give 25 amp. for 4 hours or 50 amp. for 2 hours, but it is found that the ampere-hour capacity decreases as the discharge rate is increased as may be seen from the curves in Fig. 170. This particular battery had a capacity of

29 amp. for 10 hours or 290 amp.-hours at a 10-hour rate,
42.5 amp. for 6 hours or 255 amp.-hours at a 6-hour rate,
70 amp. for 3 hours or 210 amp.-hours at a 3-hour rate,
134 amp. for 1 hour or 134 amp.-hours at a 1-hour rate.

The cause of this loss of capacity at high rates of discharge is that the active acid in the pores becomes used up in forming sulphate, so that only water is left in the pores since the acid is not replenished fast enough by diffusion from the bulk of acid in the tank, the action is therefore limited to the surface layers when the rate of discharge is high and does not penetrate into the active material.

181. Ampere-hour Efficiency.—Test data is given in Fig. 170 on a particular battery which, after being completely charged, was able to deliver 134 amp. for 1 hour before the voltage had dropped to 1.7. To recharge this battery required 32 amp. for 5 hours or 150 amp.-hours before the voltage and the specific gravity had become constant. The reason for this additional quantity of electricity is that, toward the end of a charge, hydrogen and oxygen gases are given off and these require a definite

quantity of electricity for their formation, which electricity is not available on discharge because the gases have escaped.

If the charged battery is now discharged at 42.5 amp. the voltage does not drop to 1.75 until after 6 hours and the output is 42.5×6 or 255 amp.-hours. The action being slower has gone deeper into the plates and more active material has been turned into sulphate, but, just because of this increased depth of action it is not advisable to allow the voltage to drop so far. To recharge this battery now requires 32 amp. for 9 hours or 288 amp.-hours.

The number of ampere-hours required to charge a battery is greater than the number taken out during the previous discharge and the ratio $\frac{\text{ampere-hours output}}{\text{ampere-hours input to recharge}}$ is called the ampere-hour efficiency of the battery.

From the test curves in Fig. 170 the following results are determined:

Discharge			Charge			Amp.-hour efficiency, per cent.
Amp.	Hours	Amp.-hours	Amp.	Hours	Amp.-hours	
134	1	134	32	5.1	164	82
70	3	210	32	7.7	246	85
42.5	6	255	32	9.0	288	89
29	10	290	32	10.	320	91

From these figures it may be seen that the higher the rate of discharge the lower the ampere-hour efficiency, the charging rate being the same in each case. The reason for this is that when the discharge rate is high the output is small so that the useful input of the next charge is small and the portion used in forming gases is proportionately large.

182. Watt-hour efficiency.—This quantity

$$\begin{aligned}
 &= \frac{\text{watt-hours output}}{\text{watt-hours input to recharge}} \\
 &= \frac{\text{amp.-hours output} \times \text{average discharge voltage}}{\text{amp.-hours input} \times \text{average charging voltage}} \\
 &= \text{amp.-hour efficiency} \times \text{volt efficiency}
 \end{aligned}$$

both of which quantities are lower, the higher the rate of charge and discharge.

With floating batteries, which are used to carry peak loads

of short duration and are not charged and discharged completely, there is little or no gassing and the ampere-hour efficiency is almost 100 per cent., while the peak voltages at the end of a charge and the very low voltages at the end of a discharge are avoided and the volt efficiency is high. Thus, while a battery in a central station supplying a lighting load of several hours' duration will have an average watt-hour efficiency over a period of 12 months of 74 per cent., a similar battery in a central station supplying a traction load, the load on the battery being intermittent, will have an average watt-hour efficiency of 84 per cent. over a period of 12 months.

183. Effect of Temperature on the Capacity.—In general, the cooler a battery is kept the longer is its life but the lower the capacity. Lowering the temperature of the electrolyte increases its internal resistance and causes an increased drop for a given current. The curves in Fig. 171 show how large is the drop in capacity when the temperature is lowered; the temperature was

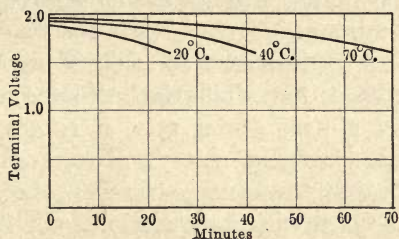

FIG. 171.*—Discharge curves of a lead cell with the same current but at different temperatures.

maintained constant during any one test by means of circulating water.

The salvation of a battery in cold weather lies in the fact that it is self warming, the internal resistance and therefore the I^2R loss become greater as the temperature decreases. For electric-truck work in cold climates it is advisable to lag the batteries, or at least to place them in a wind-proof compartment. The temperature on charge should be limited to about 40° C.; continual operation at higher temperatures tends to reduce the life of the cell.

184. Limit of Discharge.—As pointed out on page 152, a battery should not be allowed to discharge to a voltage below about 1.8 because there is then an excess of sulphate formed on

*Liagre, *L'Éclairage Électrique*, Vol. 29, p. 150; Nov. 2, 1901.

the plates and a tendency for the plates to buckle and to sulphate permanently. The amount of charge in a battery is best determined by measurements of the specific gravity of the electrolyte since this gives a measure of the amount of acid that has gone to form sulphate on the plates. The specific gravity may readily be measured by a hydrometer of the type shown in Fig. 172.



FIG. 172.—Hydrometer for testing the specific gravity of the electrolyte.

The voltage of a battery is not an accurate index of its condition because the voltage depends largely on the rate of discharge. Voltage readings on open circuit are of no value because this voltage is almost independent of the amount of charge still in the battery.

185. Treatment of Lead Cells.—From a study of the action of lead cells, the treatment they should receive may be determined. The manufacturers' instructions should be followed in every case but the following points require special attention.

A large part of the wear of plates is due to gassing so that, while the beginning of a charge may be at the 2-hour rate, it is advisable to keep the charging rate slow toward the end of a charge; the average charge rate of 8 hours should be used whenever possible.

Cells should be overcharged about once a month to get rid of the last traces of sulphate and also to even up the cells and make sure that they are all charged up to their full capacity.

Too rapid discharging causes the sulphate to form rapidly and tends to cause buckling, this will seldom cause trouble in a well-designed battery. Overdischarge however must be avoided, the terminal voltage not being allowed to drop below 1.8 at the normal 8-hour rate nor below 1.75 at the 4-hour discharge rate.

The cell should not be allowed to stand discharged for any length of time. If a battery has to stand idle for several months it should be charged monthly because even a small leakage current will cause enough sulphate to form on the plates to cause trouble if it turns into the insoluble form. This monthly charge should be continued until there is no further rise in voltage or of specific

gravity and until the cell has been gassing for about 5 hours, one may then be reasonably sure that no sulphate has been left on the plates.

Evaporation of the electrolyte should be made good by the addition of pure water; the acid does not evaporate and, unless there is excessive spraying due to the gases given off, the quantity of acid in the cell will not change.

The specific gravity of the acid used depends on the use to which the cell will be put while the permissible change in the specific gravity depends on the bulk of acid in the cell and should be obtained from the maker. When the cell has to stand inactive for long periods, a weak acid is used to lessen the risk of sulphation. For automobile work, the quantity of acid in the cell should be such that the specific gravity shall not change more than from 1.28 to 1.17 between full charge and full discharge; for other service a range of from 1.23 to 1.15 is more usual, the gravity being measured at a temperature of 70° F.

Before removing sediment from a cell, the plates should be fully charged, then taken out and the separators removed. The plates and tank should then be washed with water and the whole battery put back into commission before the plates have time to dry.

The gases formed during overcharge are explosive so that a naked flame should be kept away from the battery room. The room also should be well ventilated and the floor and walls should be of some acid-resisting material such as vitrified brick. The room should be obscured from direct sunlight, which tends to warp the plates; a heating system should be put in if the battery has to operate in a cold climate, so as to maintain the capacity under all conditions.

186. Action of the Edison Battery.—If a plate of nickel oxide (NiO_2) and one of iron (Fe) are placed in a solution of caustic potash (KOH), a battery is formed with the nickel oxide plate at the higher potential.

If current is drawn from this battery, the oxide (NiO_2) is reduced to a lower oxide (Ni_2O_3) while the iron is oxidized to form FeO , and the cell is gradually discharged;



If now current from some external source is forced through the cell in the opposite direction so as to cause electrolysis, the

action is completely reversed. The negative O ions are attracted to the positive Ni_2O_3 and the higher oxide NiO_2 is reformed while the positive H ions are attracted to the negative FeO and reduce it to iron

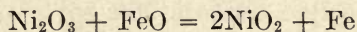

the result of charge and discharge is a transfer of oxygen from one plate to the other; the strength of the electrolyte is not changed so that the quantity required is less than for an equivalent lead cell.

After the battery has been completely charged, the hydrogen and oxygen appear as gases which bubble up through the electrolyte just as in the lead cell.

187. Construction of the Plates.—The positive or nickel plate shown in Fig. 173 consists of a nickel-plated steel grid carrying perforated steel tubes, one of which is shown in diagram B. These tubes are heavily nickel plated and are filled with alternate layers of nickel hydroxide and flaked metallic nickel. The hydroxide is acted on electrochemically and becomes nickel oxide. This oxide is such a poor conductor of electricity that the flaked nickel is added to bring the inner portions of the oxidè into metallic contact with the surface of the tubes and thereby reduce the internal resistance of the cell.

Each tube has a lapped spiral seam to allow for expansion, and is reenforced with steel rings to prevent the tube from expanding away from and breaking contact with the enclosed active material.

The negative or iron plate shown in Fig. 173 consists of a nickel plated steel grid holding a number of rectangular pockets filled with powdered iron oxide. Each pocket is made of two pieces of perforated steel ribbon flanged at the side to form a little flat box which may be filled from the end.

188. Construction of an Edison Battery.—A number of like plates are connected in parallel to form a group, there being one more plate in the negative than in the positive group. Two sets of plates are then sandwiched together as shown in Fig. 174, adjoining plates being separated from one another by strips of hard rubber. End insulators A are provided with grooves which carry the edges of the plates, and thereby act as spacers and at the same time insulate the plates from the steel tank. The outside negative plates are insulated from the tank by sheets of hard

rubber, while the whole unit rests on the rubber rack *B* by which the plates are insulated from the bottom of the tank; this rack is shallow since very little space is required for sediment in an Edison cell.

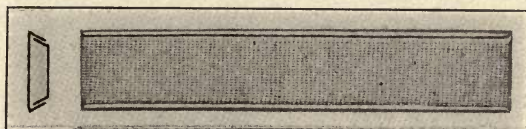

A. Pocket for negative plate.



B. Tube for the positive plate.

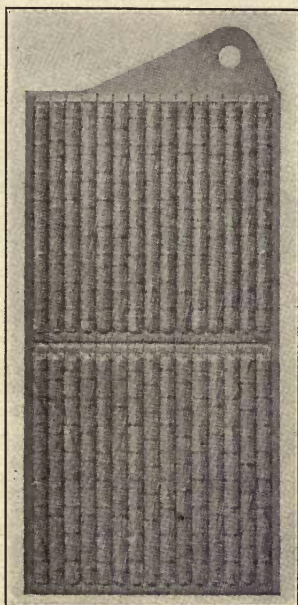

Positive plate

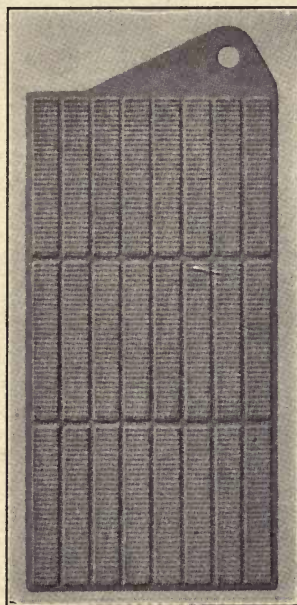

Negative plate.

FIG. 173.—Plates of an Edison Battery.

The tank, which is made of cold rolled steel welded at the joints, is corrugated for strength as shown in Fig. 175 and is heavily nickel plated as a protection against rust. The cover is of the

same material and is welded to the rest of the tank after the plates have been put in place. This cover carries two terminals, as well as a combined gas vent and filling aperture *A*. When the cover *b* is closed, the hemispherical-valve *a* closes the aperture and prevents the escape of electrolyte, but allows the gases generated on overcharge to escape as soon as the pressure in the tank becomes high enough to raise the valve.

The electrolyte used consists of a 21 per cent. solution of potash in distilled water to which a small amount of lithia is

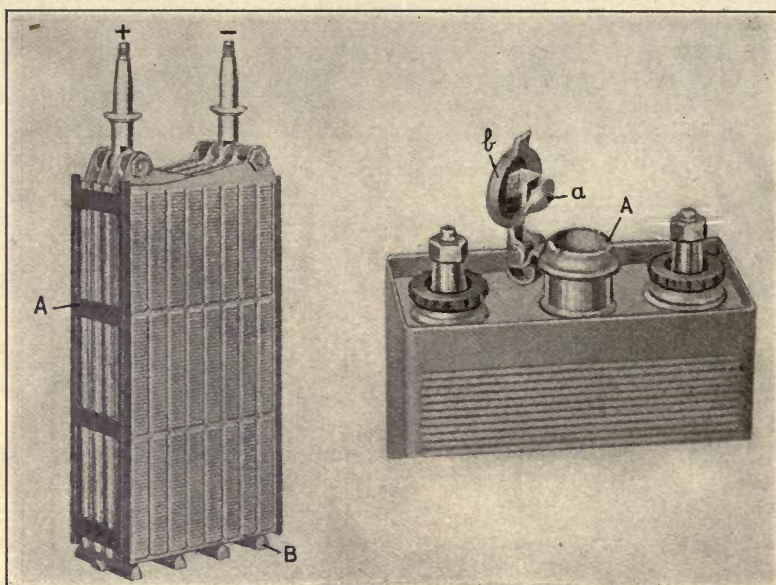

FIG. 174.—Plate groups of an Edison cell.

FIG. 175.—Top of the jar of an Edison cell.

added. No corrosive fumes are given off from this electrolyte so that no special care need be taken in mounting the cells.

189. The Voltage of an Edison Battery.—Fig. 176 shows how the voltage of an Edison battery changes when the battery is charged and then discharged. The voltage characteristics are similar to those of a lead battery.

There is no lower limit to the voltage of an Edison battery because in it there is nothing equivalent to sulphation, but discharge is not continued below a useful lower limit.

190. Characteristics of an Edison Battery.—These batteries are rated at a 7-hour charging rate and a 5-hour discharge rate

with the same current in each case, the ampere-hour efficiency being about 82 per cent. at this rate and the internal heating not more than permissible. A higher rate of discharge may be used so long as the internal temperature does not exceed about 45° C.; continual operation at higher temperatures shortens the life of the cell. A longer charge rate than 7 hours should not be used because, with low currents, the iron element is not completely reduced; this however does not permanently injure the cell but makes it necessary to overcharge the cell at normal rate and then discharge it completely to bring it back to normal condition.

Because of the comparatively high internal resistance of the

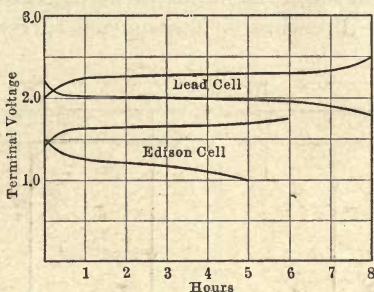

FIG. 176.—Charge and discharge curves of a lead cell and an Edison cell.

Edison battery, the volt efficiency is lower than in the lead cell, as may readily be seen from Fig. 176, and, since the ampere-hour efficiency is not any higher, the watt-hour efficiency of the Edison cell is also lower.

The great advantages of the Edison cell are that it is lighter than the lead cell and is more robust, it can remain charged or discharged for any length of time without injury, and so little sediment is formed that the makers seal it up. Since no acid fumes are given off, the cell may be placed in the same room as other machinery without risk of corrosion of that machinery.

The chief disadvantage of the Edison cell, in addition to its high cost, is that its efficiency is lower than that of the lead cell.

CHAPTER XXIV

OPERATION OF GENERATORS

191. Operation of the Same Shunt Machine as a Generator or as a Motor.—The generator G , Fig. 177, driven in the direction shown, supplies power to the mains mn . The same machine, operating as a motor from mains of the same voltage and polarity, is shown at M ; the direction and the strength of the shunt field are unchanged, the direction of the armature current is reversed, but

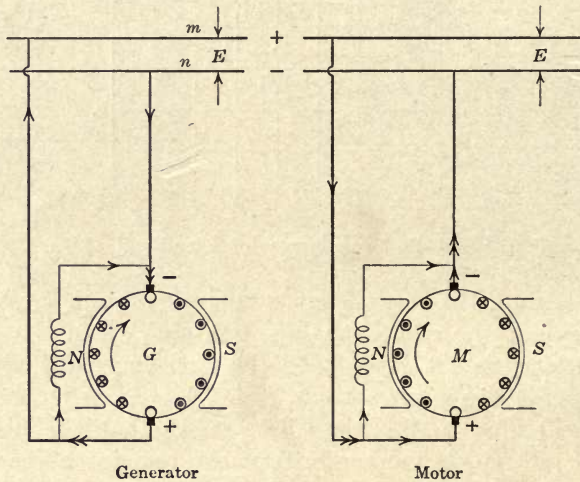

Fig. 177.—Operation of the same shunt machine as a generator and as a motor.

the direction of motion, determined by the left-hand rule, page 7 is the same as in G . Since the back e.m.f. when the machine is operating as a motor has to be practically equal to E , the e.m.f. of the machine when operating as a generator, the machine must run at the same speed in each case.

In diagram A, Fig. 178, m and n are two mains kept at a constant voltage E by the generators in a power house, and D is a single shunt generator of the same voltage running at normal speed. If the voltage E_d is exactly equal to E and the polarity

is as shown, then no current will flow in the lines a and b when the switch S is closed. If the excitation of D is now increased slightly so that the voltage generated in the machine is greater than the line voltage E , then current will flow in the direction of the generated voltage, as shown in diagram B, and the machine, operating as a generator, will supply power to the circuit mn . If now the excitation of D is decreased so that the voltage generated in the machine is less than the line voltage E , then current will flow in the direction of the greater voltage, that is, in a direction opposite to that of the generated voltage, as in diagram C, and the machine, operating as a motor in the same direction as before, will take power from the circuit mn . Thus by merely varying the excitation of D it may be made to act as a generator or as a motor.

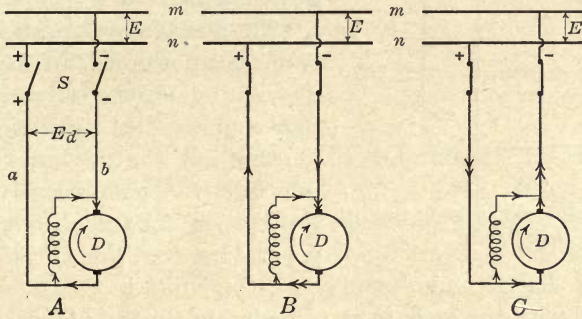

FIG. 178.—Operation of the same shunt machine as a generator and as a motor.

192. Loading Back Tests.—Load tests on large electrical machines must be made by some method whereby the power developed by the machine is not dissipated but is made available for the test, otherwise the power-house capacity may not be large enough to allow many machines to be tested, while the cost of such tests will be excessive.

If the machine to be tested is a generator, it is driven at normal speed by a motor of the same voltage but of larger capacity, and both machines are connected to the power house mains as shown in Fig. 179. The motor M is started up by means of a starting box in the usual way, and the generator G is excited until its voltage is equal to E , the switch S_1 is then closed and a voltmeter V is placed across the switch S_2 . If the reading of this voltmeter is twice normal voltage, then the polarity of G must be

reversed by reversing the shunt field, but if the reading is zero, then the switch S_2 may be closed and the generator G thereby connected to the mains. There will then be no current in the leads a and b so that the generator will be running light, and the motor will be taking from the power house only that power required to operate the two machines at no-load.

If the excitation of G is now increased so as to increase its generated voltage, then current will flow in the direction shown; the machine will deliver power to the circuit mn while the motor M , which drives G , will take from this same circuit an amount of power equal to the output of G plus the losses in the two machines, of which the portion required to supply the losses is all that is taken from the power house since the output of G is sent back into the power mains.

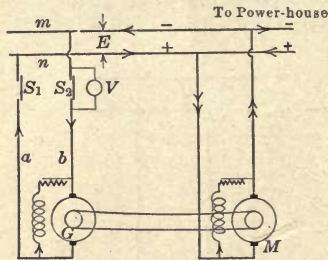

FIG. 179.—Loading back test on a generator.

193. Parallel Operation.—The load on a power station is generally distributed among several generators connected in parallel with one another, so that a breakdown of one unit will not seriously cripple the station. Parallel operation of generators has the additional advantage that the number of generating units in operation can be changed with the load, so as to maintain the individual machines at approximately full-load, at or near which load they operate with their highest efficiency.

194. Shunt Generators in Parallel.— A and B , Fig. 180, are shunt generators which feed into the same mains m and n . Suppose that A has been carrying all the load and that it has become necessary to connect generator B to the mains to share the load. This latter machine is brought up to speed with the switch S open, its field rheostat is adjusted until E_b is equal to E , and the switch S is closed. The load on B is then zero. To make the two machines divide the load, the excitation of B is increased so as to increase its generated voltage and thereby cause the machine to deliver current to the mains.

If, due to a momentary increase in speed or for some other reason, machine A takes more than its proper share of the total load, the voltage of A drops since it is a shunt generator, see page 73, and part of this load is automatically thrown on B , the machine with

the higher voltage at that instant. Furthermore, if the engine connected to *B* fails for an instant, that machine slows down, its generated voltage drops and the load is automatically thrown on *A*; if this generated voltage drops far enough, then current flows from the line to operate machine *B* as a motor at normal speed and in the same direction as before, see page 162, but, as soon as the engine recovers, this machine again takes its share of the load. The operation of two shunt machines in parallel is therefore stable, each machine refuses to take more than its proper share of the load and yet helps the other machine when necessary.

To disconnect machine *B*, its excitation should be reduced until *A* is carrying all the load, the switches *S* may then be opened.

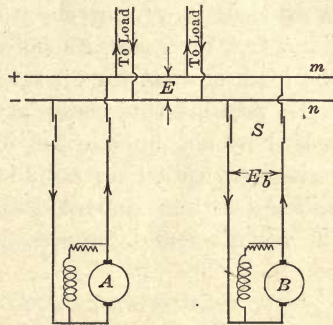

FIG. 180.—Parallel operation of shunt generators.

195. Division of Load among Shunt Generators in Parallel.

The external characteristics of the two shunt generators are shown in Fig. 181. When the line voltage is *E*, the currents in the machines are *I_a* and *I_b* and the line current is *I_a* + *I_b*. If the current drawn from the mains

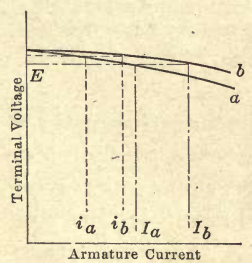

FIG. 181

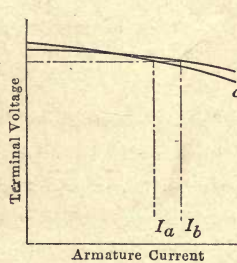

FIG. 182

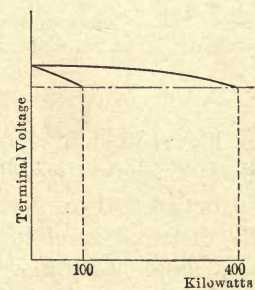

FIG. 183

FIGS.—181, 182 and 183.—Division of load between two shunt generators in parallel.

decreases, the voltage *E* rises and the currents in the two machines are then *i_a* and *i_b* when the line current is *i_a* + *i_b*.

To make machine *A* take a larger portion of the total load, its excitation must be raised so as to raise its characteristic as shown in Fig. 182.

If a 100-kw. and a 400-kw. machine have the same regulation

and therefore the same drop in voltage from no-load to full-load then, as shown in Fig. 183, the machines will divide the load according to their respective capacities.

196. Compound Generators in Parallel.—*A* and *B*, Fig. 184, are two compound generators which are operating in parallel. If, due to a momentary increase in speed, machine *A* takes more than its proper share of the total load, the series excitation of *A* increases, its voltage rises, and it takes still more of the load, so that the operation is unstable.

To prevent this instability, the points *e* and *f*, Fig. 185, are joined by a connection of large cross section and of negligible resistance, called an equalizer connection. The series coils *P* and *Q* are thus connected in parallel with one another between the equalizer and the negative main *n*, as is shown more clearly

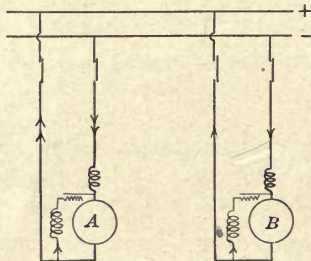

FIG. 184.—Compound generators in parallel.

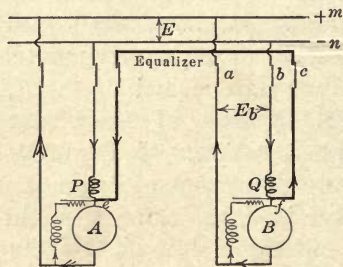

FIG. 185.—Compound generators in parallel, an equalizer being supplied and the machine *A* being over-loaded.

in Fig. 186, and the total current from the negative main *n* always passes through these coils in one direction and divides up between them inversely as their resistance, independently of the distribution of the load between the machines. If now, due to a momentary increase in speed, machine *A* takes more than its proper share of the total load, as shown in Fig. 185, and therefore less is left for machine *B*, the series excitation of the two machines is unchanged, since the total load is unchanged, so that the machines act as shunt generators with a constant superimposed excitation and the voltage of *A* decreases and that of *B* increases, and part of this load is automatically thrown on *B*, the machine with the higher voltage; the operation of the machines has therefore been made stable by the addition of the equalizer connection.

To connect machine *B* in parallel with machine *A* which is already running, bring the machine up to speed with the switches *a*, *b*, and *c* open, close switches *b* and *c* in order to excite the series coils, then adjust the shunt excitation until E_b is equal to E , and finally close switch *a*, the machine may then be made to take its share of the load by increasing its shunt excitation. To disconnect the machine, its shunt excitation should be reduced until all the load has been transferred to *A*, the switches should then be opened in the reverse order.

For large machines three separate switches are generally used. For smaller machines the switches *b* and *c* are often combined to form a double pole switch. When the machines are a considerable distance from the mains *m* and *n*, the equalizer is often run straight between the machines as shown in Fig. 186.

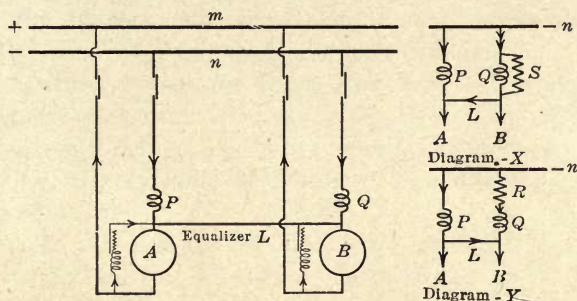

FIG. 186.—Compound generators in parallel, showing methods of changing the compounding.

197. Division of Load among Compound Generators.—When a single compound generator has too much compounding, a shunt in parallel with the series field coils will reduce the current in these coils and so reduce the compounding, page 77.

When one of a number of compound generators in parallel is found to take more than its share of the load, then its compounding must be reduced, this, however, can no longer be accomplished by placing a shunt in parallel with the series coils of that machine, for example the shunt *S* will not only reduce the current in the series coils *Q* but will, at the same time reduce the current in the series coils *P* since the two sets of series coils and the shunt *S* are then all connected in parallel between the negative main and the equalizer, as shown in diagram X, and the total line current will divide among them inversely as their resist-

ance. The compounding of both machines will therefore be reduced.

To reduce the current in the series coils Q without at the same time reducing that in the coils P , a resistance must be placed in series with Q as shown in diagram Y.

CHAPTER XXV

OPERATION OF GENERATORS AND BATTERIES IN PARALLEL

198. Isolated Lighting Plants.—The engine and generator capacity in such plants is generally sufficient for the total number of lamps connected, but since the lamps are seldom all in use at one time, the plant operates at partial load and consequently with low efficiency. When a suitable storage battery is installed, the generator may be operated for a few hours to charge the battery and may then be shut down, the battery being left connected to supply the load current.

199. Lighting Plants for Farm Houses.—The equipment for such plants is shown diagrammatically in Fig. 187, 30-volt tungsten lamps being used since they have stronger filaments than 110-volt lamps and can therefore be made in smaller sizes, see page 353.

The voltage of a lead cell varies from about 2.65 volts on full charge to 2.2 volts at the beginning of discharge and 1.8 volts at the end of discharge, so that if 16 cells are connected in series then:

the battery voltage on full charge	=	16×2.65	=	42.5 volts,
at the beginning of discharge	=	16×2.2	=	35.2 volts,
at the end of discharge	=	16×1.8	=	28.8 volts.

If the voltage across the lamps is raised much above 35 volts, then the 30-volt lamps will be burnt out, so that the lamp circuit must be disconnected while the generator is charging the battery.

Specify the generator and battery for a lighting plant with a connected load of 24 tungsten lamps of 15 watts and 12 candle power each.

watts per lamp = 15

current per lamp = $15/30 = 0.5$ amp.

current for 24 lamps = $0.5 \times 24 = 12$ amp.

battery capacity at normal 8-hour rate = $12 \times 8 = 96$ amp.-hours

maximum generator voltage = 16 cells at 2.65 volts = 42.5 volts

charging current at 8-hour rate = 12 amp.

generator output = $12 \times 42.5 = 510$ watts

If the average daily load on the battery is 6 lamps for 4 hours then the ampere-hours taken each day = $(6 \times 0.5) \times 4 = 12$ and a 96-amp.-hour battery will supply this load for $96/12$ or 8 days without having to be re-charged.

To prevent the generator from being connected in parallel with the battery except when its voltage is higher than the battery voltage, an automatic switch S is supplied. To charge the battery, the lights are disconnected, the generator which is shunt wound is started up by the engine, and the shunt rheostat r is gradually cut out to raise the generator voltage until the value is reached for which the solenoid F was set, the pull of this solenoid then closes the switch S and connects the generator in parallel with the battery. The generator then delivers current to the battery, which current flowing through the coil H , adds to the pull of F and helps to keep the switch S closed.

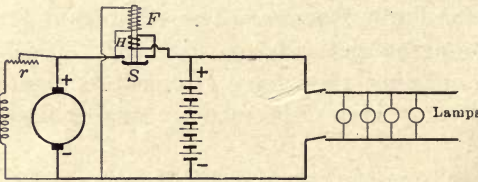

FIG. 187.—Connection diagram for a small isolated lighting plant.

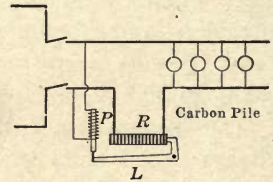

FIG. 188.—Lamp circuit regulator.

If, due to a loose field connection or for some other reason, the generator voltage drops below that of the battery then current flows back through the coil H in such a direction as to oppose the pull of F ; the switch S is thereby released and the generator disconnected from the circuit. The switch S therefore acts as a **reverse current circuit breaker**.

200. Lamp Circuit Regulator.—One objection to the above system is that the voltage across the lamps varies with the battery voltage from 35.2 to 28.8 and the life of the lamps is shortened due to the high voltage while the lighting is unsatisfactory when the voltage is below 30 volts. This trouble may be overcome by the addition of an automatic regulator. A very simple type of regulator for this purpose is shown diagrammatically in Fig. 188 and consists of a carbon pile resistance

R inserted in the lighting circuit, and a shunt solenoid P by which the pressure on the carbon pile is varied. If the voltage across the lamp circuit increases, the current in the solenoid P increases and lifts the lever L , thereby reducing the pressure on the carbon pile R and increasing its resistance, so that the voltage drop across the carbon pile increases and the lamp voltage remains approximately constant. A more elaborate regulator of this type is described on page 182.

201. Small Isolated Power Stations.—In such stations, provision must be made for charging the battery and also for carrying the day load at the same time. This is accomplished either by resistance control, end cell control or booster control.

202. Resistance Control.—To take the case of a 110-volt plant. The number of cells in series is $110/1.8 = 60$ and, to charge them in series, would require a maximum voltage of $60 \times 2.65 =$

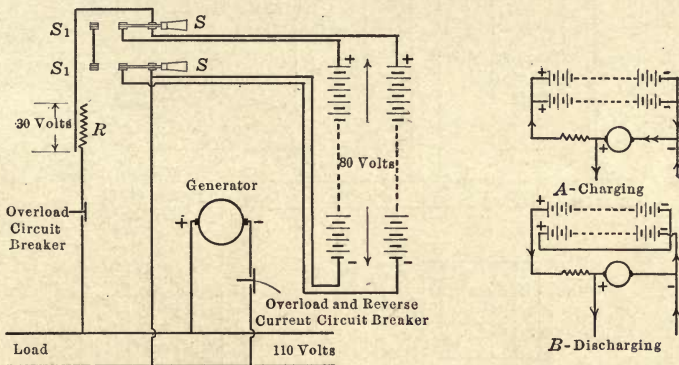

FIG. 189.—Resistance system of battery control.

160 volts. But since the day load has to be carried by the generators while the battery is being charged, it is not permissible to raise the generator voltage above 110 volts. This difficulty is overcome by dividing the battery into two halves for charging purposes and connecting them to the generator as shown in Fig. 189, the maximum battery voltage during charge will then be 80 volts and the remaining part of the 110 volts must be used up in the resistance R , by means of which resistance the charging current may be regulated.

When the battery is fully charged the cells are reconnected in series by throwing the switches over into position S_1 and, since the battery voltage at the beginning of discharge is

60×2.2 or 132 volts while the generator voltage is only 110 volts, the same resistance R must be kept in the battery circuit to control the discharge.

203. End Cell Control.—With this system of control, shown diagrammatically in Fig. 190, the battery is charged in series from a generator which has a voltage range up to 160 volts, the charging current being regulated by the generator field rheostat. Two end cell switches C_1 and C_2 are required so that the 110-volt load may be supplied while the battery is being charged.

When the battery is at the end of discharge, the number of

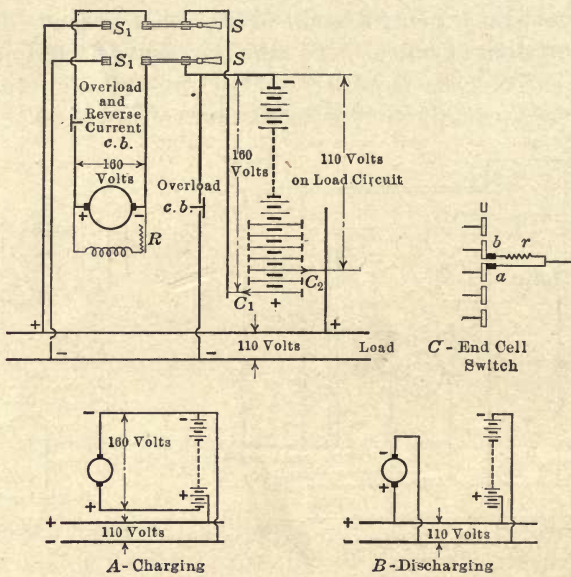

FIG. 190.—End cell system of battery control.

cells for 110 volts is $110/1.8$ or 61 while at the beginning of discharge $110/2.2$ or 50 cells are all that are required, and 11 end cells must be so arranged that they can be gradually connected in circuit as the battery discharges. When the end cell switches are in the position shown in Fig. 190, there are 50 main cells and 4 end cells on the lighting circuit while all the cells are being charged in series; these 4 cells on the lighting circuit will gradually be cut out as the battery becomes more fully charged and the voltage rises.

When the battery is fully charged, the switches are thrown over

into the position S_1 and the generator and battery are thereby connected in parallel across the mains.

In order that the end cell switch will not open the circuit when passing from one contact to that adjoining nor yet will it short circuit any one cell, this switch is generally constructed as shown diagrammatically in Fig. 190 with a main contact a and an auxiliary contact b electrically connected through a resistance r but otherwise insulated from one another. As the switch is moved over the contacts, it stands for an instant in the position shown and bridges one cell, but the resistance r keeps the current that flows through this cell from being dangerously large.

Since the end cells are gradually put in circuit as discharge proceeds, they are never so completely discharged as the rest of the battery, so that, when the battery is being recharged with all the cells in series, the end cells should be cut out one by one as they become fully charged and begin to gas freely.

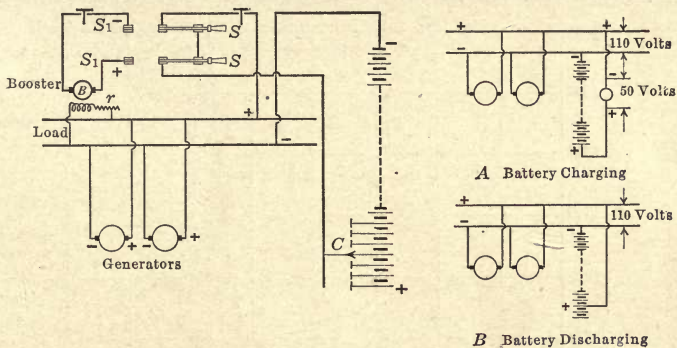

FIG. 191.—Booster charge and end cell discharge system of battery control.

With this system of control there is not the resistance loss that is present in the resistance control system, but the outfit is more costly.

204. Booster Charge, End Cell Discharge.—For larger self-contained plants, the high voltage for charging is obtained by connecting an additional generator B , called a booster, so that its voltage is added to that of the main generators. To charge the battery in Fig. 191, the switches must be thrown over into position S_1 and then, if the generated voltage is 110 and the maximum voltage on charge is 160, the booster has to supply 50 volts.

The booster is generally driven by a constant speed motor and

is excited from the generator mains, the field rheostat having sufficient resistance to allow the booster voltage to be reduced to about 2 volts.

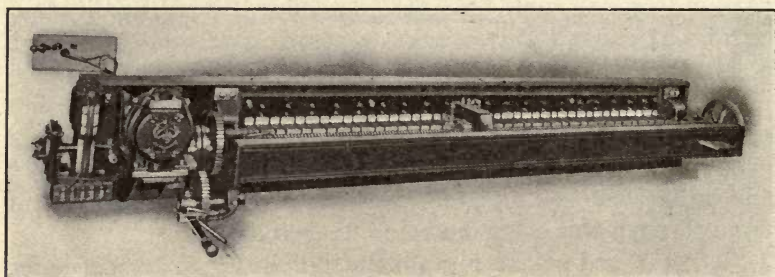

FIG. 192.—Large end cell switch.

When the battery is fully charged, the double throw switch is thrown over into the position shown in Fig. 191 so as to connect the battery directly across the mains, the discharge voltage is

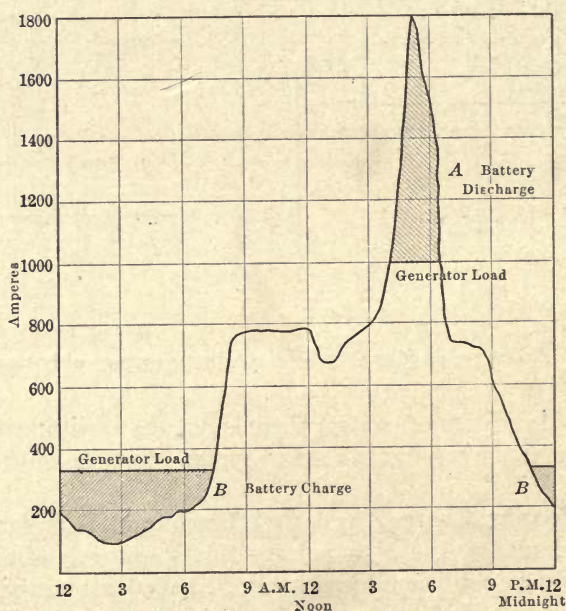

FIG. 193.—Daily load curve on a small station.

then regulated by the end cell switch *C*. The booster may be used for this purpose if the discharge current is not too large, see next article.

The end cell switch for such plants, when of large size, generally takes the form shown in Fig. 192, a laminated brush being moved across a series of contacts by a motor-driven operating screw. This motor may be provided with push-button control if desired.

205. Capacity of Battery.—The irregular curve in Fig. 193 is the load curve on a small power station, and a battery is required to supply all the current over 1000 amp.

The battery discharge = cross hatched area *A*
= 1140 amp. hours

the time of discharge = 2.7 hours

the average discharge current = 420 amp.

the maximum discharge current = 800 amp.

When the discharge takes place at the 2.7-hour rate, the capacity of the battery is only 75 per cent. of the normal capacity, see page 153, therefore the normal capacity of the above battery = $1140/0.75$
= 1500 amp.-hours.

To recharge the battery, about 20 per cent. more ampere-hours must be put in than were taken out on the previous discharge when this discharge was at the 2.7-hour rate, see page 154.

therefore:

the charge required = 1140×1.20
= 1370 amp.-hours
= shaded area *B*

the battery charges for 8.7 hours

the maximum charging current = 230 amp.

or is at the $1500/230 = 6.5$ -hour rate

the average charging current = $1370/8.7 = 157$ amp.

the booster has to carry a maximum of 230 amp. and must be designed for a maximum voltage of 50 the output is therefore $50 \times 230 = 11.5$ kw.

This booster could not be used to help the battery to discharge because the 800-amp. discharge current would burn up a 230-amp. booster, end cells must therefore be supplied.

In working out this problem it has been assumed that the battery will never be called on to deliver more than 1140 amp.-hours at the 2.7-hour rate.

No attempt has been made to determine whether or not the above outfit is the most suitable for the particular service, this is a question which can be answered only by trial of different combinations of generating and storage equipment, the total operating cost including maintenance and depreciation being figured out in each case.

206. Batteries for Rapidly Fluctuating Loads.—The load on the power house of plants such as rolling mills fluctuates so rapidly that hand-operated boosters and end cells cannot follow the fluctuations and automatic control becomes necessary. Only two of the many systems that have been devised will be described, the principle in each case being to control the field excitation of the booster by means of the load current in such a way that, when the load is heavy the booster will assist the battery to discharge, and when the load is light the booster will assist the generators to charge the battery.

207. The Differential Booster in its simplest form is connected as shown in Fig. 194 and is supplied with a set of shunt coils *A* and a set of series coils *B* which coils are connected so that their m.m.fs. are in opposition. With normal load on the generator,

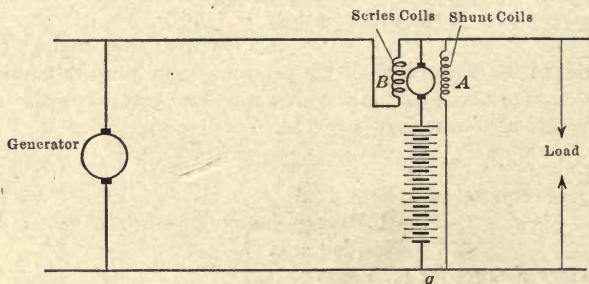

FIG. 194.—Differential booster system of battery control.

the m.m.f. of the series coils is equal and opposite to that of the shunt coils and the resultant magnetic field is zero, so that the booster voltage is zero and the battery neither charges nor discharges.

If the load on the generator increases, the series excitation of the booster becomes greater than the shunt excitation and the booster voltage is then added to the battery voltage and causes the battery to discharge and carry the larger part of the excess load. If the generator load now becomes less than normal then the series excitation decreases and the shunt excitation is now the greater so that the booster voltage is reversed, opposes the battery voltage, and thereby helps the generator to charge the battery.

208. Carbon Pile Regulator.—The diagram of connections for a booster system controlled by a carbon pile regulator is shown in Fig. 195. The booster *B* is excited by the coil *E* which takes

current from a small exciter, the field excitation of which is controlled by a regulator consisting of two carbon piles r_1 and r_2 . These carbon piles are subjected to pressure by the lever L , to

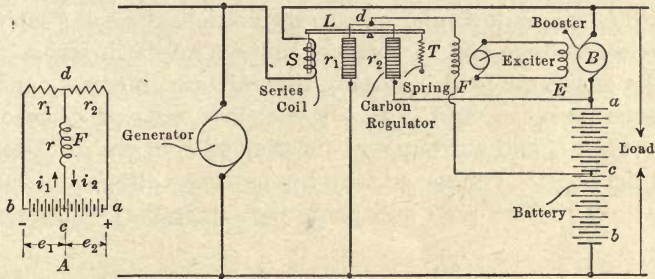

FIG. 195.—Carbon pile regulator for the automatic control of a battery.

one end of which is attached the plunger of the operating solenoid S and to the other end a spring T , the tension of which may be adjusted to counterbalance the pull of the solenoid when any

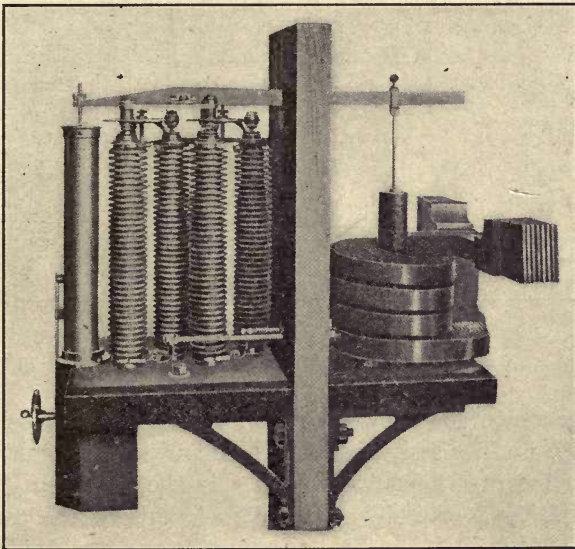

FIG. 196.—Carbon pile regulator for a battery.

desired current is flowing through it. The diagram of connections of the exciter field coil circuit is shown in diagram A . The voltage e_1 tends to send a current $i_1 = e_1 / (r + r_1)$ through

the coil F while the voltage e_2 tends to send a current $i_2 = e_2/(r+r_2)$ through the same coil in the opposite direction.

If the generator load is normal then the pull of the solenoid S is equal to the pull of the spring T and r_1 is then equal to r_2 , i_1 is equal to i_2 , diagram A , and no current flows in the coil F , so that the exciter voltage and the booster voltage are both zero.

If the generator load increases, the pull on r_1 increases and its resistance decreases and is now less than r_2 so that i_1 becomes greater than i_2 and current flows in the coil F in the direction of i_1 and the booster voltage adds to the battery voltage and causes the battery to discharge and carry the larger part of the excess load.

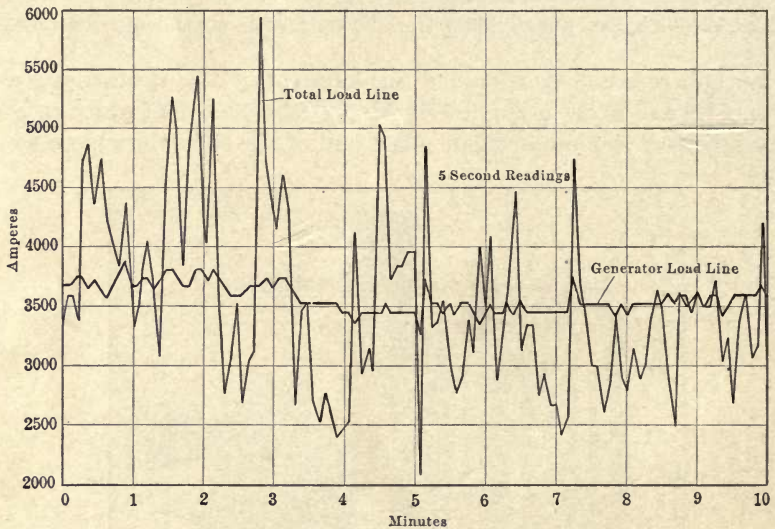

FIG. 197.—Load curves on the power house of a steel mill.

If the generator load now becomes less than normal, the pull on r_1 decreases and its resistance increases and is now greater than r_2 and current now flows in the coil F in the direction of i_2 , the booster voltage is thereby reversed and adds to the generator voltage and thereby helps the generators to recharge the battery.

The curves in Fig. 197 show how nearly constant the generator load may be maintained by such a regulator, while the indicator cards in Fig. 198 show the effect of the regulator in maintaining the steam consumption constant, an operating condition which is favorable to economy in steam consumption.

The average load on the generator is that at which the pull of the solenoid S is exactly counterbalanced by the tension of the spring T , for then the booster field excitation is zero; this load may be adjusted by varying the tension of the spring.

One advantage of the externally controlled booster over the differential booster is that the former machine is a standard shunt generator whereas the latter has special series field coils and heavy cables leading to these coils; some idea of the section of copper required for these coils and cables may be obtained from Fig. 196 which shows the section of copper required to carry the current in a carbon pile regulator.

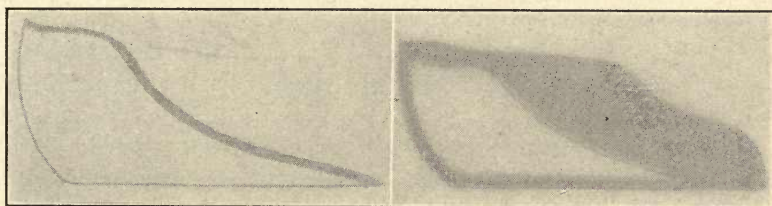

A—Battery in circuit.

B—Battery out of circuit.

FIG. 198.—Indicator cards from the steam engines in the power house of a steel mill.

209. Floating Batteries.—If a battery is connected in parallel with the generator and with the load, as shown in Fig. 199, then the condition to be fulfilled before the battery will carry the peak load is that the voltage regulation of the generator shall be worse than that of the battery, so that, as the load increases, the generator voltage drops below that of the battery and the battery has to discharge, while if the load decreases, the generator voltage rises above that of the battery and the battery is charged.

Such poor regulation is not desired in a power house, but is often found at the end of a transmission line. If the length L of this line is considerable and the section of the wire is small, then a heavy load on the line will cause the voltage to drop sufficiently to allow the battery to discharge, while with a light load on the line the drop is small and the voltage is then high enough to recharge the battery.

The exact equivalent of a line with poor regulation is shown in Fig. 200, which represents diagrammatically a hotel power plant supplying lamps L and elevator and other motors M .

The generator is flat compounded to maintain the voltage constant across the lamps, while a battery is inserted to carry the peak loads produced by the starting of the elevators. In order that the battery may operate properly, there must be a considerable drop in voltage between the generator and the battery. This is arranged for by placing a series wound booster in the

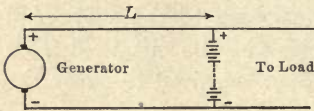

FIG. 199.—Battery floating at the end of a line.

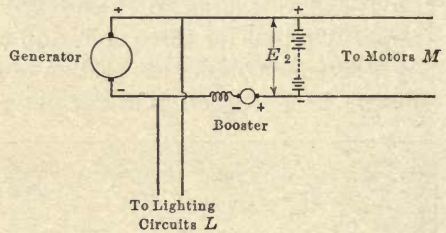

FIG. 200.—Series booster system of battery control.

circuit, the booster being driven at constant speed with its voltage opposing that of the generators, so that if the elevator motors take a large current the strength of the booster series field is increased, this causes the booster voltage to increase and the voltage E_2 to drop and thereby allows the battery to discharge.

CHAPTER XXVI

CAR LIGHTING AND VARIABLE SPEED GENERATORS

210. The essential condition to be satisfied by any system of electric lighting for vehicles is that the voltage across the lamps shall be approximately constant for all speeds of the vehicle from zero up to the maximum value.

For train lighting on steam railroads the three methods at present in use are:

a. Lighting from storage batteries, called the straight storage system.

b. Lighting from a constant voltage generator placed on the locomotive or in the baggage car, called the head and end system.

c. Lighting from generators which are belted to the car axle.

For motor-car lighting, power is supplied by a generator which is driven by the engine.

211. Straight Storage for Trains.—The power for the lighting load in this case is supplied entirely by storage batteries which are carried under the cars. At the end of each run the batteries must be recharged or else replaced by fully charged batteries.

212. Head and End System.—The lighting load in this case is supplied by a 100-volt compound wound generator driven at constant speed by a turbine which takes steam from the locomotive. The generating unit may be mounted on the locomotive or in the baggage car.

In order that the lights on the train may not go out if the train is parted or if the locomotive is disconnected, storage batteries must be placed on at least the front and the rear cars the general practice being to place a battery on each car. The system is then suitable for long runs where cars are not parted and where no interchange of equipment is made with other roads.

The standard battery equipment for such service, if a lead battery is used, consists of 32 cells in series so that

the battery voltage on full charge	= 32 × 2.65 = 85 volts
at the beginning of discharge	= 32 × 2.2 = 70 volts
at the end of discharge	= 32 × 1.8 = 57 volts

Since 60-volt lamps are used, an automatic regulator must be placed in the lamp circuit of each car so as to maintain the lamp voltage approximately constant.

213. Carbon Pile Lamp Regulator.—One type of regulator which depends on the variable resistance of a carbon pile for its operation is shown on the middle panel of Fig. 202 and is also shown diagrammatically in Fig. 201.

If the battery is being charged, then the voltage E_b increases and the lamp voltage E_l also increases slightly. This increases the pull on the plunger a which increases the pressure on the carbon pile r and decreases its resistance, more current therefore flows in the coil b which is connected in series with r across the lamp circuit, so that the plunger b is raised and the pressure on the carbon pile R is decreased and its resistance increased, the

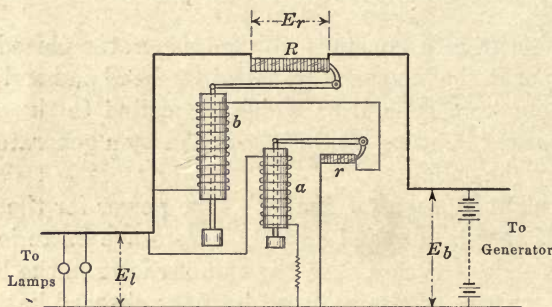

FIG. 201.—Lamp circuit regulator.

greater part of the increased battery voltage is therefore absorbed by the resistance R and the lamp voltage remains approximately constant. Due to the multiplying effect of the auxiliary solenoid a and carbon pile r , a slight change in the voltage across the lamps produces a considerable change in the pull of the solenoid b .

214. The Axle Generator Systems.—With these systems, the lighting equipment of each car is self contained and consists of a generator driven from the car axle and a storage battery to supply power when the car is at standstill.

An automatic switch must be provided so that the generator shall be connected to the battery only when the generator voltage is higher than the battery voltage and shall be disconnected when its voltage is lower. The generator also must be so controlled that the charging current shall not be excessive and

shall moreover be reduced automatically as soon as the battery is fully charged. The combined automatic switch and generator regulator shown on the bottom panel of Fig. 202 and diagrammatically in Fig. 203 is typical of the several carbon pile regulating systems on the market.

215. Automatic Switch.—As the car speeds up, the generator voltage increases and when it reaches a value which is greater than the maximum battery voltage the pull on the plunger *P* due to the current in *F* becomes large enough to close the switch *S* and connect the generator and the battery in parallel. The generator then delivers current to the lamps and to the battery which current, flowing through the coil *H*, adds to the pull on the plunger and helps to keep the switch closed.

If the car now slows down, the speed finally reaches a value below which the generator voltage is less than that of the battery, and current flows back through the coil *H* in such a direction as to oppose the pull of *F*, so that the switch *S* is released and the generator disconnected from the circuit, the battery being left connected to supply power to the lamps.

216. Generator Regulator.—As the speed of the generator increases, the voltage of the generator and the charging current in the battery both increase. This charging current is limited by the regulator shown diagrammatically in Fig. 203 which consists of a carbon pile rheostat *R* in the field coil circuit and a solenoid *B* in the battery circuit. The weight of the plunger of *B* keeps the carbon pile compressed, while the upward pull of the solenoid decreases the pressure and thereby inserts resistance in the shunt coil circuit and cuts down the voltage of the machine. The regulator is adjusted so that the plunger is pulled up and

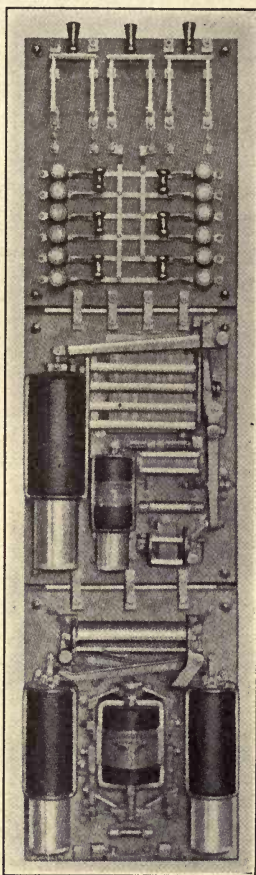

FIG. 202.—Control panel for a train lighting system.

the pressure on the carbon pile is relieved as soon as the current reaches the safe maximum charging rate of the battery.

If this were the only provision made for regulating the generator, then the battery current would be maintained even after the battery was fully charged, this would cause excessive gassing of the battery and a loss of water from the electrolyte; the generator voltage would then be $32 \times 2.65 = 85$ volts with a 32-cell battery.

In order to decrease the charging current once the battery is fully charged, an additional relay is provided which limits the generator voltage to some value lower than 85 volts. This is accomplished by the shunt solenoid *A* which is connected across the generator terminals as shown in Fig. 203. The weight of

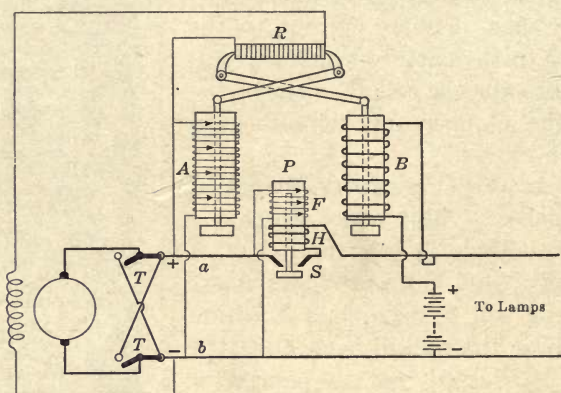

FIG. 203.—Automatic switch, and generator regulator.

the plunger of this solenoid keeps the carbon pile compressed, but when the generator voltage reaches a value somewhat lower than 85 volts the plunger is pulled up and the pressure on the carbon pile is relieved so that the voltage cannot increase further.

217. Pole Changer.—The polarity of the leads *a* and *b*, Fig. 203, must be independent of the direction of motion of the car in order that the battery-charging current may flow in the proper direction, and the generator shunt field coils are connected across *ab* instead of across the generator terminals in order that the magnetic field produced may always be in the same direction as that due to residual magnetism and may therefore build up properly, see page 71. If then the direction of motion of the car reverses, the polarity of the generator will also reverse, so that

provision must be made for reversing the connections between the brushes and the leads *a* and *b*. This may be accomplished by a double throw switch such as that shown at *T*, Fig. 203, which is thrown over by a mechanism on the generator shaft whenever the direction of rotation of the generator is reversed.

218. The Stone Generator.—The voltage and current of this generator are controlled by the slipping of the driving belt. The generator is suspended by an adjustable link *L*, Fig. 204, and is therefore free to swing toward or away from the driving pulley on the axle. The belt is then adjusted to pull the generator out of the position in which it would naturally hang and the tension put on the belt by this means may be so adjusted by the link *L* that the belt will slip when the load exceeds a certain value.

The combined automatic switch and pole changer is at the commutator end of the machine, see Fig. 205. The contacts *B*

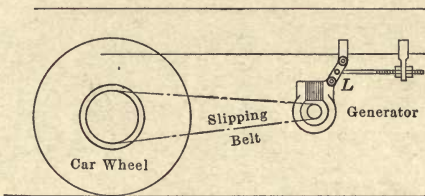

FIG. 204.—Suspension of a slipping-belt type of generator.

are fixed while the contacts *A* are carried on a rocker arm *C* which is loose on the shaft and is carried around by friction in the direction of rotation until arrested in the position shown by a stop, the blade *A*₁ is then opposite *B*₁ and *A*₂ opposite *B*₂. If the rotation had been in the opposite direction, the arm *C* would have been carried around in this direction until *A*₁ was opposite *B*₂ and *A*₂ opposite *B*₁ when the motion of the arm would have been arrested by another stop.

When the speed and the voltage of the generator reach such a value that the generator is able to charge the battery, then the weights *w* are thrown out and the arm *C* with the switch blades attached is pushed along so as to connect the generator and the battery in parallel. If the speed decreases to such a value that the generator is no longer able to charge the battery, then the spring *S* pulls the switch blades out of contact and disconnects the generator.

The various operations take place in the following order. When

the car starts up, the rocker arm *C* moves around to its proper position, and when the speed becomes high enough, the switches *AB* are closed and the generator charges the battery. As the speed increases, the generator voltage and the charging current both increase until the load becomes large enough to cause the belt to slip, the speed of the generator will then increase no further nor will the charging current in the battery increase. This system has given satisfaction although its efficiency is not so high as that of some of the other systems because of the loss in the slipping belt, it also has the objectionable feature that the charging current is not reduced after the battery is fully charged.

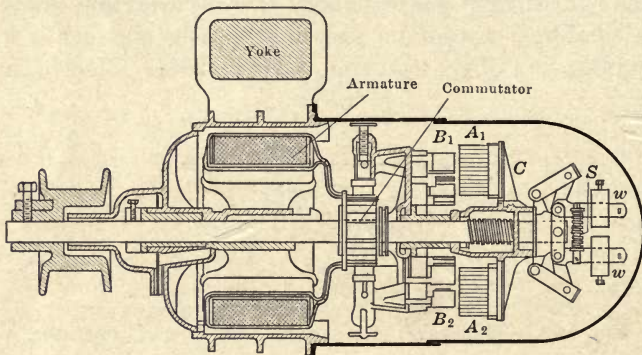

FIG. 205.—The Stone train lighting generator.

219. Lighting Generators for Motor Cars.—The equipment for motor-car lighting is similar to that supplied for train lighting except that a pole changer is not required since the generator, which is driven by the engine, always rotates in one direction when the speed is such that the generator is connected in parallel with the battery.

220. Constant Speed Generators.—Several machines operate on the same principle as the Stone train lighting generator, the slipping belt being replaced by a slipping clutch in order to make the outfit as compact as possible. This clutch slips when the generator output reaches a predetermined value.

221. Bucking Field Coils.—Differentially compounded generators have been successfully used for vehicle lighting, the field windings being connected as shown in Fig. 206 where *A* is a shunt winding which is connected across the battery and therefore

gives approximately constant excitation while *B* is a series winding which acts in opposition to or bucks the shunt winding.

When the speed of the generator reaches such a value that the generator is able to charge the battery, the automatic switch closes. As the speed increases further, the generator voltage and the charging current both increase, but this charging current passes through the coils *B* and reduces the excitation of the machine, so that the charging current is limited. The charging current can never exceed the value at which the ampere-turns of winding *B* is equal to the ampere-turns of winding *A* for then the flux in the machine and the generated voltage would both be zero.

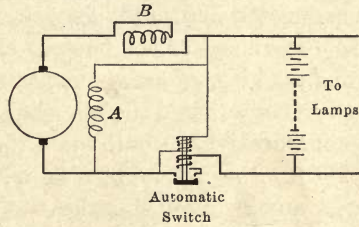

FIG. 206.—Generator with bucking field coils.

222. Vibrating Contact Regulator.—A compact and efficient regulator for a variable speed generator is shown diagrammatically in Fig. 207, the car being at standstill. As the car speeds up, the generator voltage increases and, when it reaches a predetermined value, the pull of the magnet *M* due to the shunt coil *a* closes the main switch *S* and connects the battery and the generator

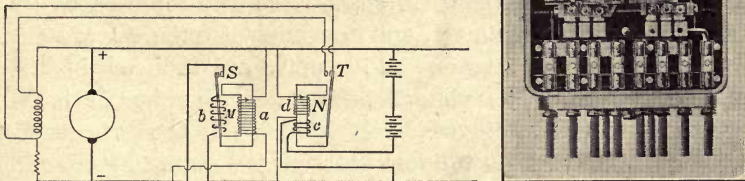

FIG. 207.—Vibrating contact regulator for a variable speed generator.

in parallel. The generator then delivers current to the battery and to the lamps which current, flowing through the coil *b*, adds to the pull of the magnet and helps to keep the switch *S* closed.

As the speed of the generator increases, the voltage of the generator and the charging current in the battery both increase. This current flows through the coil *c* and, when it becomes equal

to the safe charging current of the battery, the pull of the magnet N closes the contact T and short circuits the generator field coils thereby reducing the excitation and limiting the voltage of the machine, the battery is therefore protected from excessive charging currents.

In order to decrease the charging current once the battery is fully charged, an additional coil d is placed on the magnet N and is connected across the generator terminals. The voltage across coil d increases as the battery charges until finally the current in coil d is able to close the contact T , the voltage can then increase no further so that the charging current gradually decreases and is comparatively small when the battery is fully charged.

For motor-car work, a lamp circuit regulator is considered to be an unwarranted complication since the battery voltage changes slowly and the lamp voltage may be adjusted by means of a hand operated rheostat if desired.

223. The Rosenberg Generator.—Diagram A, Fig. 208, shows a generator with the field coils excited from a battery so as to produce a flux ϕ . When the armature revolves in the direction of the arrow, e.m.fs. are induced in the conductors, the directions of which are shown by crosses and dots, and the voltage between the brushes BB is E_1 , while that between the brushes bb is zero since the e.m.fs. in the conductors from b_1 to a are opposed by those in the conductors from a to b_2 . If the brushes BB are joined, then current will flow through the armature and will produce an armature cross field ϕ_{1a} , see page 67.

Consider now the effect of this cross field ϕ_{1a} acting alone. Since this field is stationary in space it can be represented by poles N_2S_2 as in diagram B, and the lines of force ϕ_{1a} are cut by the armature conductors and e.m.fs. are induced in the directions shown. The voltage between the brushes bb is E_2 while that between the brushes BB is zero. If the brushes bb are joined, then current will flow through the armature and will produce an armature cross field ϕ_{2a} .

In one form of the actual machine shown in diagram C, the poles N_1S_1 are excited from the battery while N_2S_2 have no field coils but carry the cross flux ϕ_{1a} . The brushes BB are short circuited while the brushes bb are connected to the load.

As the speed of the generator increases then, referring to diagram A, the voltage E_1 increases causing the current I_1 and the flux ϕ_{1a} to increase; referring now to diagram B, the voltage

E_2 increases with the flux ϕ_{1a} and causes I_2 and ϕ_{2a} to increase. But ϕ_{2a} opposes ϕ and demagnetizes the machine, and the greater the speed the greater the demagnetizing effect, so that I_2 increases by a smaller and smaller amount and over a wide range of speed remains practically constant. The current I_2 can never exceed the value with which ϕ_{2a} is equal to ϕ because then the flux in the machine would be zero.

Such a machine is therefore a constant current generator,

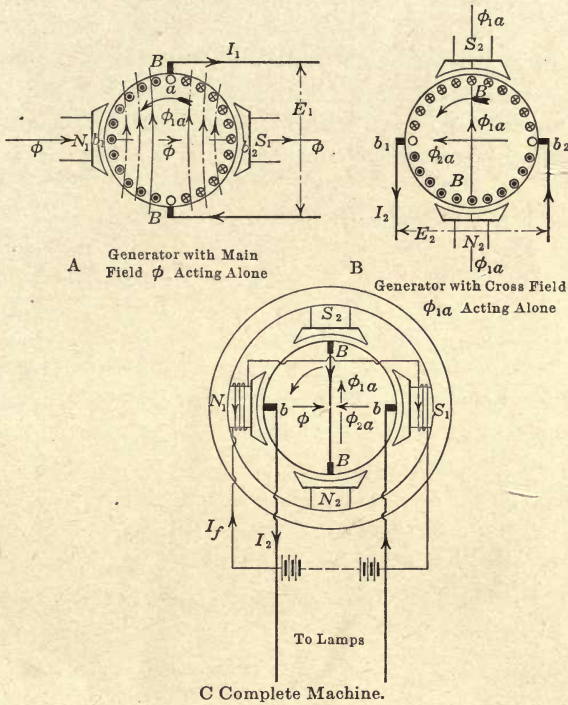

FIG. 208.—Rosenberg train lighting generator.

and by adjusting the exciting current I_f , the current I_2 can be limited to the normal charging current of the battery; the charging current however does not decrease as the battery becomes fully charged, a disadvantage this generator possesses in common with the slipping belt type of generator.

The operation of this generator is described in detail because it has several interesting applications. It is used for train lighting, when it is called the Rosenberg generator; a similar machine called the C. A. V. generator is used for motor cars. The machine has

also been used as a constant current generator for the operation of the arc of large searchlights and also for arc welding, since it is practically fool-proof and can be short circuited across the operating brushes *bb* without the current exceeding the normal value.

CHAPTER XXVII

ALTERNATING VOLTAGES AND CURRENTS

224. The Simple Alternator.—If the coil $abcd$, Fig. 209, be rotated between the poles N and S so that the conductors ab and cd cut lines of force, an alternating e.m.f. will be found between f and g , the ends of the coil. The direction of the e.m.f. in each conductor, found by the right-hand rule (page 9), is shown in diagrams A, B, C and D for different positions of the conductors relative to the poles. In diagram A the conductors are not cut-

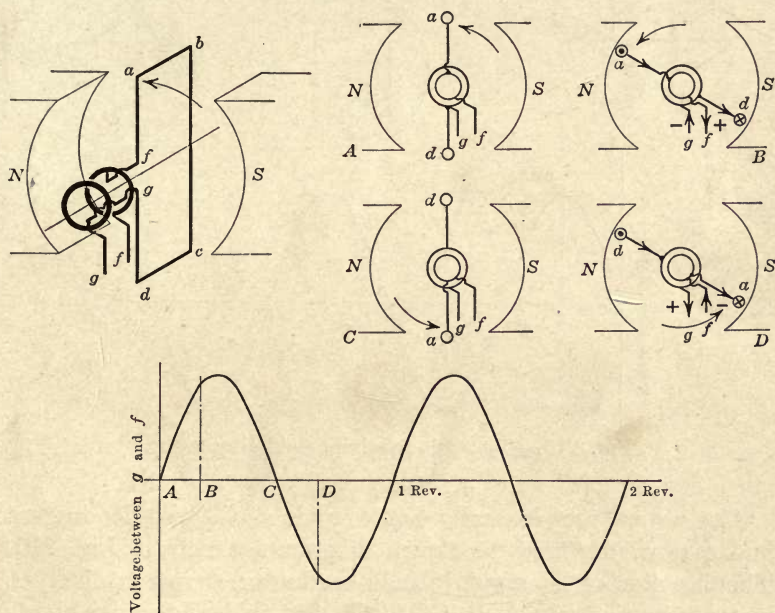

FIG. 209.—Simple two-pole alternator.

ting lines of force, and the e.m.f. between f and g is zero. In diagram B the e.m.fs. in the conductors are in such a direction as to force current from f to g through the external circuit, therefore f is the positive and g the negative terminal of the machine. In diagram C the e.m.f. between f and g is again zero. In dia-

gram D the e.m.fs. in the conductors are in such a direction as to force the current from *g* to *f* through the external circuit, therefore *g* is now the positive and *f* the negative terminal. The current in the external circuit connecting *f* and *g* therefore alternates; that is, electricity oscillates backward and forward in the circuit.

If the e.m.f. between *f* and *g* is plotted against time then a curve such as that in Fig. 209 is obtained.

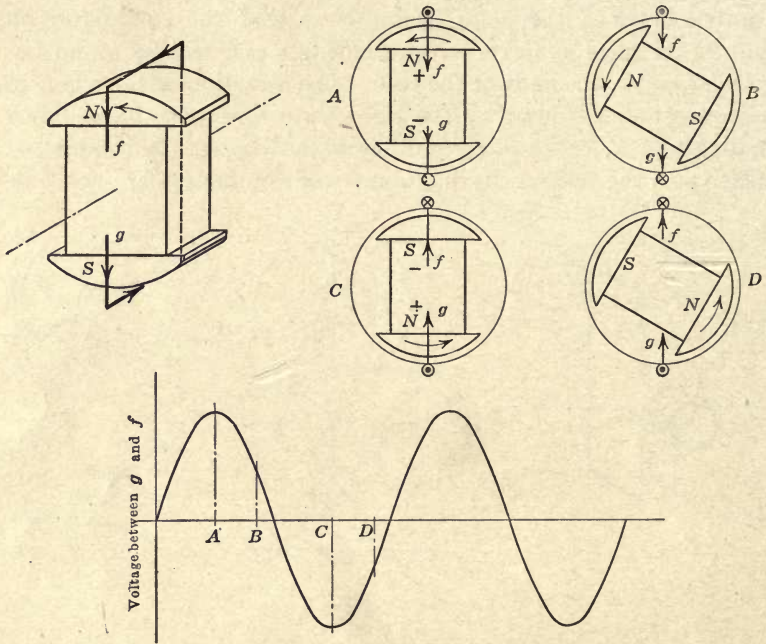

FIG. 210.—Two-pole revolving-field alternator.

Alternators are generally made with stationary conductors and a revolving field, as shown diagrammatically in Fig. 210. The direction of the e.m.f. in each conductor, shown at different instants in diagrams A, B, C and D, may be found by the right-hand rule;¹ it must be noted that in the case of a revolving-field machine the thumb is pointed in a direction opposite to that of the motion of the poles since, according to the rule, it must be

¹Thumb—direction of motion of conductor relative to magnetic field.
 Forefinger—direction of lines of force.
 Middle finger—direction of e.m.f.

pointed in the direction of motion of the conductors relative to the poles.

225. The Wave Form.—If the air-gap clearance under the pole is uniform in thickness then the lines of force crossing the air gap are spaced as shown in Fig. 211, and the e.m.f. in a conductor, being proportional to the rate of cutting of lines of force, varies as in curve A. By shaping the pole face, however, as in Fig. 212, the flux density in the air gap and therefore the rate of cutting of lines of force may be so regulated that the e.m.f. in a conductor shall vary according to a sine law as shown in curve B. The e.m.f. is then said to be simple harmonic and may be represented by the formula $e = E_m \sin \theta$.

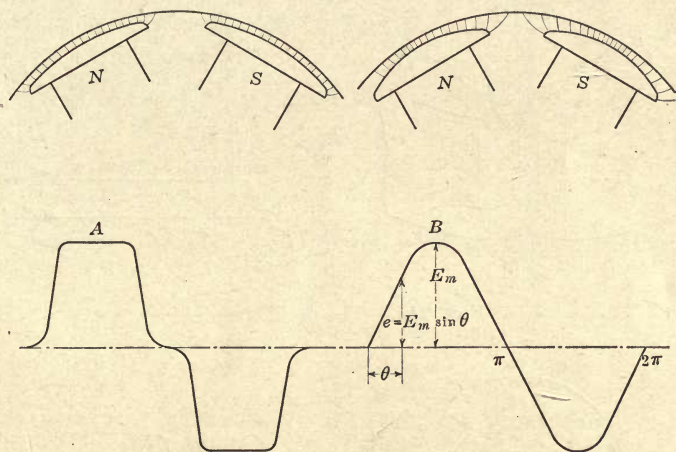

FIG. 211.

FIG. 212.

FIGS. 211 AND 212.—Wave form of electromotive force.

226. The Oscillograph.—The shape or form of the e.m.f. wave of an alternator may readily be determined by means of an instrument called an oscillograph, the essential parts of which are shown in Fig. 213.

In the narrow gap between the poles NS of a magnet are stretched two parallel conductors ss formed by bending a strip of phosphor bronze back on itself over an ivory pulley P . A spiral spring attached to this pulley serves to keep a uniform tension on the strips, and a guide piece L limits the length of the vibrating portion to the part actually in the magnetic field. A small mirror M bridges across the strips as shown.

If current is passed through the strips ss then one strip will

advance and the other will recede and the mirror will thereby be tilted about a vertical axis. If the current is alternating then the mirror will tilt backward and forward with a frequency equal to that of the current, and the deflection will be proportional to the current. (The natural frequency of vibration of the mirror is at least fifty times the frequency of the current.)

If now a beam of light is directed on the mirror, the reflected beam will move to and fro in the horizontal plane, its displace-

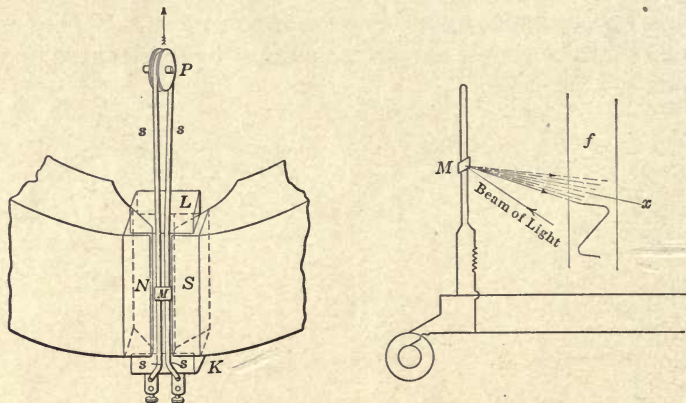

FIG. 213.—The oscillograph.

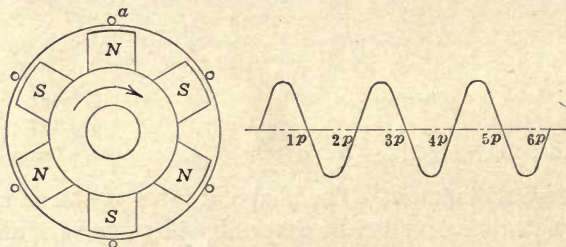

FIG. 214.—Six-pole alternator.

ment from the zero position c being proportional to the current flowing, so that if a photographic film f is moved downward at a constant speed a curve will be traced on it by the beam of light, which curve will be the wave of the e.m.f. applied at the oscillograph terminals.

227. Frequency.—In the two pole machine shown in Fig. 209, the e.m.f. between the terminals passes through a complete cycle while the machine makes one revolution. In the six-pole machine

shown in Fig. 214, the e.m.f. in any conductor a passes through three cycles, one cycle per pair of poles, while the machine makes one revolution.

If, in an alternator, p is the number of poles then

$$\text{the cycles per revolution} = \frac{p}{2}$$

$$\begin{aligned} \text{and the cycles per sec., called the frequency,} &= \frac{p}{2} \times \frac{r.p.m.}{60} \\ &= \frac{p \times r.p.m.}{120} \end{aligned}$$

and is represented by the symbol f .

The frequencies generally found in practice in America are 25 and 60 cycles per sec., while in Europe 25 and 50 cycles per sec. are more common.

A 60-cycle alternator has 24 poles, at what r.p.m. must it be run?

$$\begin{aligned} f &= p \times \text{r.p.m.}/120 \\ \text{therefore } 60 &= 24 \times \text{r.p.m.}/120 \\ \text{and r.p.m.} &= 300. \end{aligned}$$

The following table gives the relation between poles, speed and frequency:

Poles	Revolutions per minute		
	25 cycles	50 cycles	60 cycles
2	1500	3000	3600
4	750	1500	1800
6	500	1000	1200
8	375	750	900
p	$3000/p$	$6000/p$	$7200/p$

It is important to note that an alternator has a definite speed for a given frequency and cannot be run above or below that speed without changing the frequency. In a direct-current generator, the voltage may be varied by varying the speed, but in the case of an alternator this cannot be done without at the same time changing the frequency.

228. Vibrating Reed Type of Frequency Meter.—In this type of instrument a number of steel strips are fastened at one end as shown in Fig. 215, while the current whose frequency is to be determined is passed through the coil A . The reeds are attracted twice in a cycle by the electromagnet B and that reed which has a natural frequency equal to twice the frequency of the current

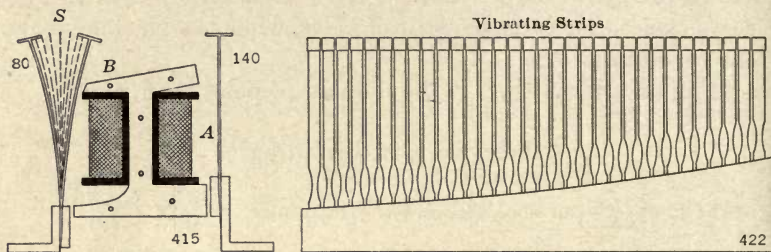

A—Interior construction.

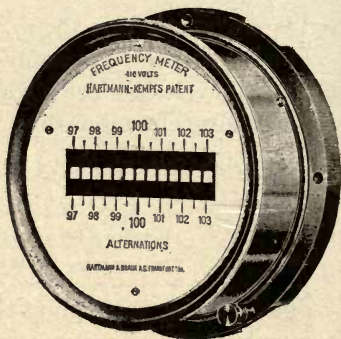
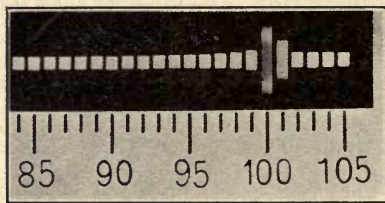

B—Scale when the frequency is 100 cycles. C—External appearance.
FIG. 215.—Vibrating reed type of frequency meter.

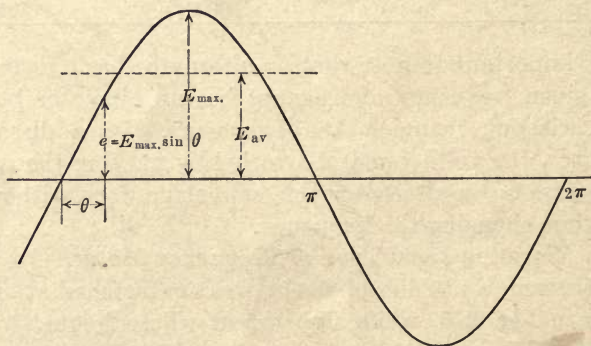

FIG. 216.—Average value of an alternating electromotive force

will be set in violent vibration. The reeds have their free ends whitened and appear as white bands when vibrating. The external appearance of such an instrument is shown in diagram C.

229. Average Value of Current and Voltage.—The average value of an alternating current or voltage is zero because similar sets of positive and negative values occur. The term average is generally applied to the average value during the positive part of a cycle as indicated in Fig. 216.

$$E_{av}, \text{ the average e.m.f.} = \frac{2}{\pi} E_m^1$$

$$I_{av}, \text{ the average current} = \frac{2}{\pi} I_m$$

230. The Heating Effect of an Alternating Current.—If a direct current I is forced through a resistance of R ohms then the power transformed into heat = I^2R watts.

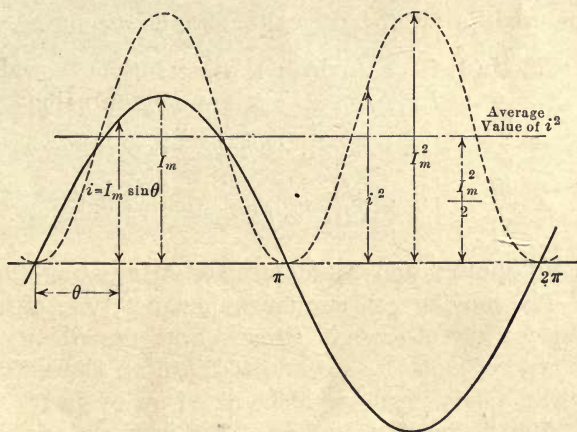

FIG. 217.

If an alternating current $i = I_m \sin \theta$ is forced through the same resistance, then the power transformed into heat at any in-

$$\begin{aligned} {}^1E_{av} \times \pi &= \int_0^\pi e \, d\theta = \int_0^\pi E_m \sin \theta \, d\theta \\ &= - \left[E_m \cos \theta \right]_0^\pi \\ &= 2 E_m \end{aligned}$$

therefore

$$E_{av} = \frac{2}{\pi} E_m$$

stant = $i^2 R$ watts and the average power transformed into heat

$$\begin{aligned} &= \text{the average value of } i^2 R, \text{ see Fig. 217.} \\ &= \text{the average value of } (I_m \sin \theta)^2 R \\ &= I_m^2 R \text{ (average value of } \sin^2 \theta)^1 \\ &= \frac{I_m^2 R}{2} \\ &= I_{eff}^2 R \end{aligned}$$

where $I_{eff} = I_m / \sqrt{2}$ is called the effective current.

When an alternating current or voltage is specified it is always the effective value that is meant unless there is a definite statement to the contrary, thus an alternating current of 10 amp. is one which has the same heating effect as 10 amp. direct current and has a maximum value of $10\sqrt{2}$ or 14.1 amp. and an average value of $\frac{2}{\pi} \times 14.1$ or 9 amp.

231. Symbols.—Hereafter in the text the following symbols shall be used for alternating voltages and currents:

$$\begin{aligned} e &= E_m \sin \theta; \quad i &= I_m \sin \theta; & \text{the instantaneous value} \\ E_m & & I_m & \text{; the maximum value} \\ E_{av} &= \frac{2}{\pi} E_m \quad I_{av} &= \frac{2}{\pi} I_m & \text{; the average value} \\ E &= \frac{E_m}{\sqrt{2}} \quad I &= \frac{I_m}{\sqrt{2}} & \text{; the effective value} \end{aligned}$$

232. Voltmeters and Ammeters for Alternating-current Circuits.—The moving coil permanent magnet type of instrument as used for direct-current circuits was described on page 8. If this type of meter was connected into an alternating-current circuit the moving coil would be acted on by forces tending to turn it first in one direction and then in the other but, due to its inertia, the coil itself would not move and the reading would be zero.

$$\begin{aligned} {}^1 \text{The average value of } \sin^2 \theta \times \pi &= \int_0^\pi \sin^2 \theta \, d\theta \\ &= - \int_0^\pi \frac{1}{2} (\cos 2\theta - 1) \, d\theta \\ &= - \frac{1}{2} \left(\frac{1}{2} \sin 2\theta - \theta \right)_0^\pi \\ &= \frac{\pi}{2} \end{aligned}$$

therefore the average value of $\sin^2 \theta = 1/2$.

In order that a moving coil instrument may be used for the measurement of alternating currents, the magnetic field and the current in the moving coil must alternate together. This result is obtained by replacing the permanent magnet by an electromagnet as shown in Fig. 218. The current to be measured is passed through the stationary coils *A* and through the moving coil *C* in series, and the sides of the moving coil are then acted on by forces which turn the coil against the tension of the spring *S*.

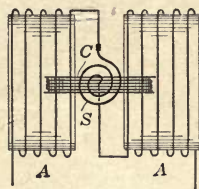
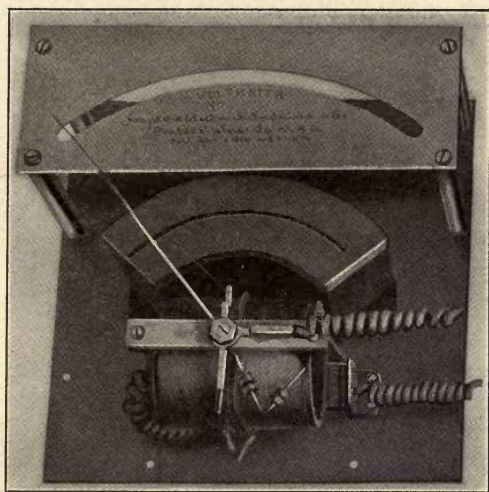

FIG. 218.—Electro-dynamometer type of instrument.

These forces are proportional to the current i in the coil *C* and to the flux ϕ produced by the current i in the coils *A*; the forces are therefore proportional to i^2 and the average turning force on the coil *C* while the current alternates is proportional to the average value of i^2 or to the effective current.

Such an instrument may be used to measure both direct and alternating currents and the reading would be the same for 10 amp. direct current as for 10 amp. effective alternating current.

CHAPTER XXVIII

REPRESENTATION OF ALTERNATING CURRENTS AND VOLTAGES

233. Part of a rotating field alternator is shown diagrammatically in Fig. 219. As the field rotates, stationary conductors

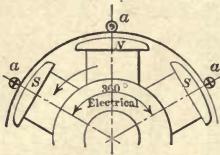

FIG. 219.

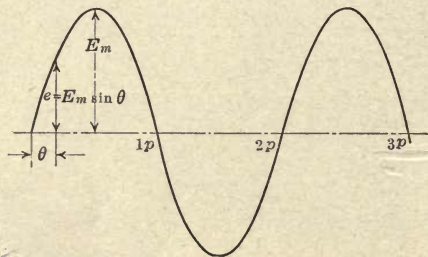

FIG. 220.

such as *a* are cut by lines of force and the e.m.f. in these conductors varies as shown in Fig. 220 and goes through one cycle for every pair of poles that pass.

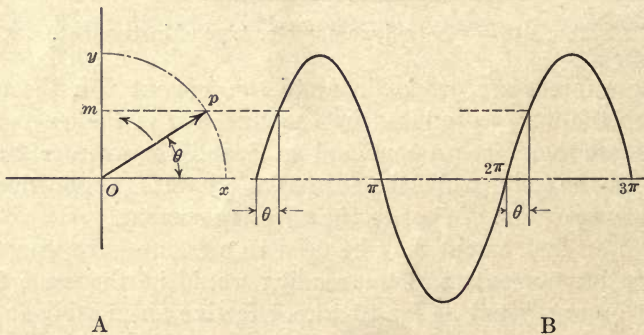

FIG. 221.—Representation of an alternating voltage.

234. **Electrical Degrees.**—If the vector *op* rotate in the counter-clock direction and the angle θ is measured from the *x*-axis then *om*, the projection of *op* on the *y*-axis = $op \sin \theta$ and its value, plotted in diagram B, passes through one cycle while θ changes through 360 degrees. If now *op* is drawn to scale equal to

E_m , Fig. 220, then $om = E_m \sin \theta$ and therefore represents the instantaneous e.m.f. e , the curves in Figs. 220 and 221 will therefore be alike in every respect if the angle the machine moves through in generating one cycle of e.m.f. is called 360 electrical degrees; in the machine in Fig. 219 this angle is that between two consecutive like poles. From this it follows that a curve such as that in Fig. 221 may be used to represent the voltage generated by an alternator with any number of poles and is the curve that would be obtained by an oscillograph.

235. Vector Representation of Alternating Voltages and Currents.—It is generally assumed that these quantities vary accord-

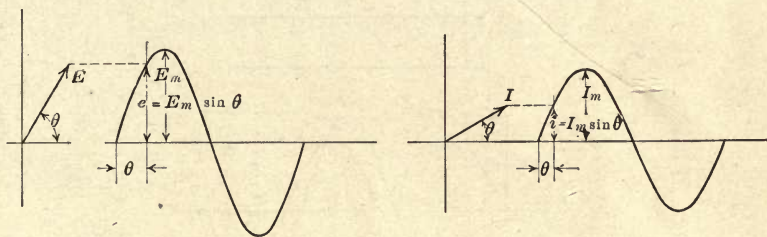

FIG. 222.—Representation of an alternating voltage and current.

ing to a sine law and can therefore be represented by sine curves as shown in Fig. 222, where

$$i, \text{ the current at any instant} = I_m \sin \theta$$

$$e, \text{ the voltage at any instant} = E_m \sin \theta$$

For much of the work on alternating-current circuits and machines it is more convenient to represent alternating voltages and currents by the corresponding vectors I and E , Fig. 222, from which vectors the sine curves may be obtained when desired by plotting the vertical components i and e against the angle θ , the vectors being rotated in the counter-clock direction.

If two oscillographs are used as in Fig. 223 one of which, A , gives the voltage curve while the other, B , gives the current curve, it will be found that the current and voltage do not necessarily reach their maximum values at the same instant but that curves such as those in diagrams A , B and C , Fig. 223, may be obtained, depending on the kind of load connected to the circuit. The reasons for the displacement of the current relative to the voltage are taken up in Chapters 29 and 30; it is necessary however to take up at this point the method of representing such curves by vectors.

If two vectors such as E and I , Fig. 224, be rotated in the counter-clock direction at the same rate, the angle α between them will remain unchanged and the vertical components $e = E_m \sin \theta$ and $i = I_m \sin \theta$, which are shown at three instants a , b and c ,

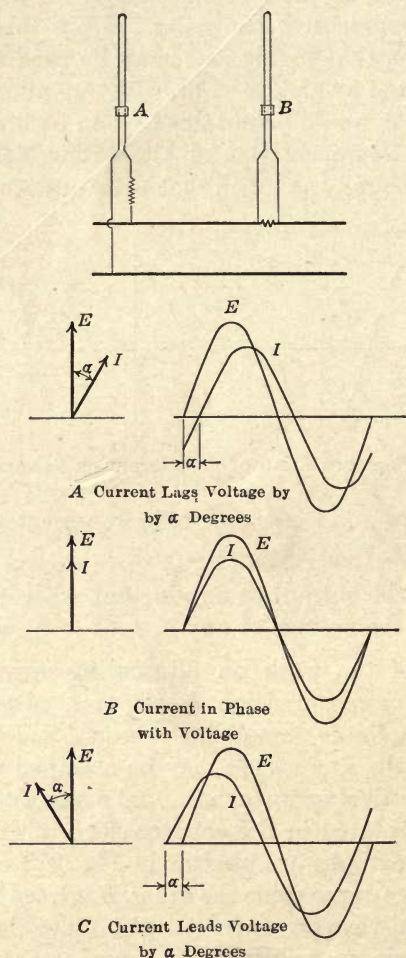

FIG. 223.—Phase relation between current and voltage.

when plotted against the angle through which the vectors have moved measured from any base line ox , will give the sine curves of E and I which curves represent a voltage and a current of the same frequency, the voltage E reaching its maximum value α degrees before the current becomes a maximum.

When the current and voltage reach their maximum values at the same instant they are said to be in phase with one another. When they reach their maximum values at different instants they are out of phase and the current is said to be leading or lag-

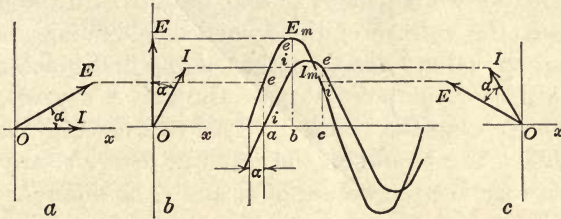

FIG. 224.—Representation of a lagging current.

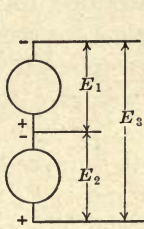

FIG. 225.

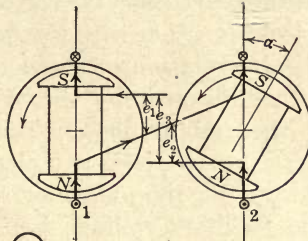

FIG. 226.

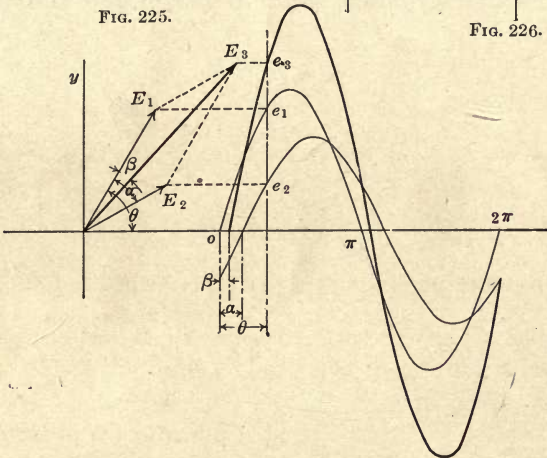

FIG. 227.—The sum of two alternating voltages of the same frequency.

ging according as it becomes a maximum before or after the voltage has reached its maximum value.

236. The Sum of Two Alternating Voltages of the Same Frequency.—If two direct-current generators are connected in

series as in Fig. 225, the resultant voltage E_3 is the numerical sum of E_1 and E_2 the voltages of the two machines.

If two alternators are connected in series as in Fig. 226, the voltage e_3 at any instant is the numerical sum of e_1 and e_2 the voltages of the two machines at that instant. In the particular case shown, the voltage of the second machine lags, or reaches its maximum value later than that of the first machine by the time required for the poles to pass through α degrees, and the curves representing the voltages of the two machines are e_1 and e_2 , Fig. 227. The points on the resultant curve e_3 are obtained by adding together the values of e_1 and e_2 at different instants.

The voltages of the two machines may be represented by the vectors E_1 and E_2 drawn to scale with an angle α between them because, if these two vectors are rotated together in the counterclock direction with this fixed angle α between them, then the vertical components e_1 and e_2 , when plotted against the angle turned through by the vectors, will give the curves e_1 and e_2 in their proper phase relation.

The resultant of these two electromotive forces is the vector sum obtained by the parallelogram law and is E_3 which represents the resultant voltage both in magnitude and in phase relation.

CHAPTER XXIX

INDUCTIVE CIRCUITS

237. Inductance.—It has been shown that whenever there is a change in the current flowing through a circuit, an e.m.f. of self induction is induced which opposes the change of the current, see page 11.

In Fig. 228, when the switch k is closed a current begins to flow in the coil and as this current increases in value the flux, ϕ

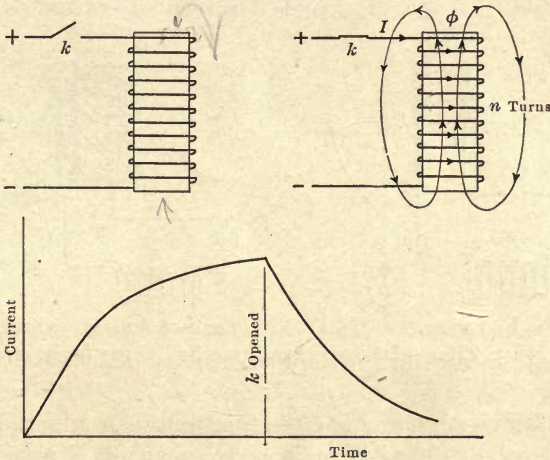

FIG. 228.—Growth and decay of current in an inductive circuit.

threading the coil also increases. Due to the change in the flux, an e.m.f. of self induction is induced in the coil which, according to Lenz's law, page 10, acts in such a direction as to oppose the increase of the current.

If, after the current has reached its final value, the switch k is suddenly opened, the current in the coil decreases, the flux threading the coil also decreases and causes an e.m.f. of self induction to be induced in such a direction as to oppose the decrease of the current. This e.m.f. is generally large enough to maintain the current between the switch contacts for a short

interval as they are opened and accounts for much of the flashing that is seen when a switch is opened in a circuit carrying current. The growth and decay of current in such a circuit is shown by the curves in Fig. 228.

That property of an electric circuit whereby it opposes a change in the current flowing is called the self induction or the inductance of the circuit; the two terms have the same meaning but the term inductance is generally used in engineering work.

238. Make and Break Spark Ignition.—One method of igniting the gas in a gas engine cylinder is based on the above properties of the inductive circuit; the essential parts of the mechanism are shown in Fig. 229.

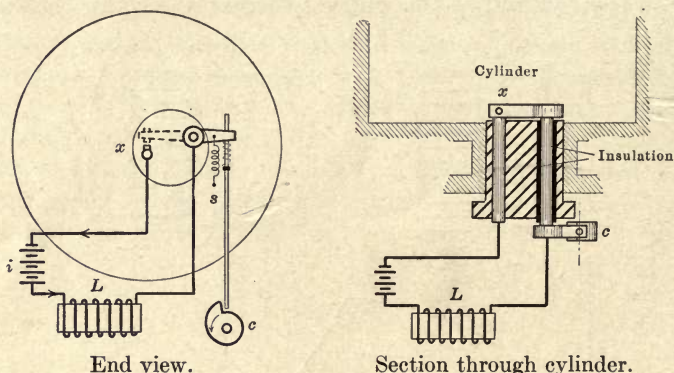

FIG. 229.—Make and break method of gas ignition.

When the contact at x is closed, current flows in the direction of the arrow. When the cam c has reached a predetermined position, the spring s opens the contact x and the current is maintained across the gap by the inductance coil L .

The current in the circuit changes as shown in Fig. 228 so that the contact x must be closed long enough to allow the current to grow to its full value, but should not be closed too long or the batteries will run down.

239. The Coefficient of Self Induction of a circuit is defined as the flux interlinkages per unit current. If, in Fig. 228, a current I produces a flux ϕ which links the n turns of the coil then the flux interlinkages = $n\phi$ and the flux interlinkages per unit current = $\frac{n\phi}{I}$.

A larger unit is used in practice and L , the coefficient of self induction in henries = $\frac{n\phi}{I}10^{-8}$ where I is in amperes.

If the current I is changing, the flux ϕ is also changing and a voltage of self induction is induced in the coil which is equal to

$$e_{si} = -n \frac{d\phi}{dt} 10^{-8} \text{ volts, see page 9}^1$$

$$\text{and since } L = \frac{n\phi}{I} 10^{-8}$$

$$\text{therefore } Ldi = n d\phi 10^{-8}$$

$$\text{and } e_{si} = -L \frac{di}{dt} \text{ volts}$$

240. Alternating Currents in Inductive Circuits.—If an alternating current is flowing in an inductive circuit then, since the current is always changing, there must be an induced e.m.f. of self induction opposing the change. If the current is represented

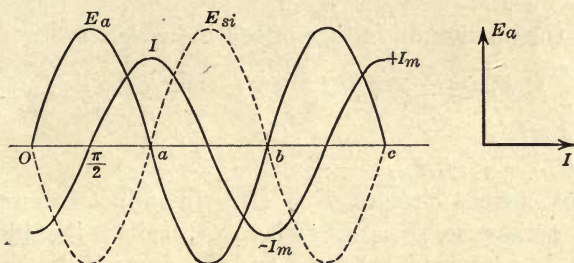

FIG. 230.—Voltage and current relations in an inductive circuit.

by curve I , Fig. 230, then between a and b , during which interval of time the current is decreasing, the e.m.f. of self induction, to oppose this decrease, must be positive, while between b and c , during which interval of time the current is increasing, the e.m.f. of self induction, to oppose this increase, must be negative. At the instants a , b and c the current is not changing and at these instants the e.m.f. of self induction must be zero. The e.m.f. which satisfies all those conditions is represented by the curve E_{si} ,² Fig. 230.

In order to force an alternating current I through a circuit, the applied e.m.f. must be large enough to overcome the e.m.f. of self induction and also the resistance of the circuit and, in the

¹The minus sign is used because the e.m.f. opposes the change of the flux.

²It is important to note that the generated voltage E_{si} lags the current i and therefore the flux θ by 90 degrees.

extreme case of an inductive circuit of negligible resistance, the applied e.m.f. must be equal and opposite to the e.m.f. of self induction. The applied e.m.f. in this latter case is represented by the curve E_a , Fig. 230, and it is important to note that, in the case of an inductive circuit of negligible resistance, the current I lags the applied voltage E_a by 90 degrees.

241. Voltage and Current Relations.—The current I in Fig. 230 changes from $-I_m$ to $+I_m$ in the time of half a cycle or in $\frac{1}{2f}$ seconds so that

$$\begin{aligned} E_{av}, \text{ the average voltage of self induction between } b \text{ and } c, \\ &= L \left(\text{average value of } \frac{di}{dt} \right) \\ &= L \left(\frac{2I_m}{\frac{1}{2f}} \right) = 4fLI_m \end{aligned}$$

and E_{maz} , the maximum voltage of self induction

$$\begin{aligned} &= \frac{\pi}{2} \times E_{av} = \frac{\pi}{2} \times 4fLI_m \\ &= 2\pi fLI_m \end{aligned}$$

therefore $E_{eff} = 2\pi fLI_{eff}$

In direct current circuits, $E = IR$. In inductive circuits of negligible resistance, $E = IX$ where X , called the inductive reactance, is expressed in ohms and is numerically equal to $2\pi fL$.

An alternating e.m.f. of 110 volts sends 2.2 amperes through an inductance coil of negligible resistance at 60 cycles. Find the reactance at 60 cycles and find also the coefficient of self induction.

$$\begin{aligned} X, \text{ the reactance} &= E/I \\ &= 110/2.2 = 50 \text{ ohms} \end{aligned}$$

$$\begin{aligned} L, \text{ the coefficient of self induction} &= \frac{X}{2\pi f} \\ &= \frac{50}{2\pi \cdot 60} = 0.133 \text{ henry} \end{aligned}$$

If the voltage applied to the above circuit is kept constant at 110, find the current that will flow through the inductance at 30, 60, 90 and 120 cycles

$$\begin{aligned} X, \text{ the reactance} &= 2\pi fL = 50 \text{ ohms at 60 cycles, from last problem} \\ &= 25 \text{ ohms at 30 cycles} \\ &= 75 \text{ ohms at 90 cycles} \\ &= 100 \text{ ohms at 120 cycles} \end{aligned}$$

$$\begin{aligned} I, \text{ the current} &= E/X = 110/25 = 4.4 \text{ amp. at 30 cycles} \\ &= 110/50 = 2.2 \text{ amp. at 60 cycles} \\ &= 110/75 = 1.47 \text{ amp. at 90 cycles} \\ &= 110/100 = 1.1 \text{ amp. at 120 cycles} \end{aligned}$$

The current is inversely proportional to the frequency because, the greater the frequency the smaller the current required to give the same voltage of self induction.

242. Power in an Inductive Circuit.—The power in a circuit at any instant in watts is the product of e and i the voltage and current at that instant. In an inductive circuit of negligible resistance the current lags the applied voltage by 90 degrees and the curves representing e and i are shown by light lines in Fig. 231.

At the instants a and b the voltage is zero so that the power is zero at these instants; it is also zero at instants g , d and f

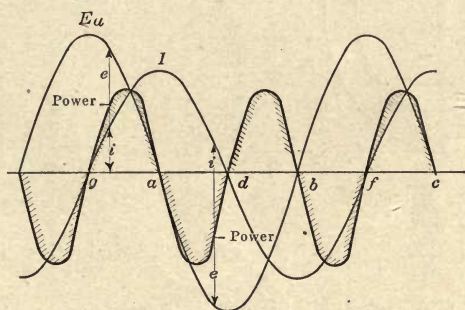

FIG. 231.—Voltage, current and power in an inductive circuit.

when the current is zero. Between g and a the voltage and current are in the same direction so that power is positive or energy is being put into the circuit, while between a and d the current and voltage are in opposite directions so that power is negative or energy is being taken from the circuit; the average power in the circuit is zero.

A hypothetical mechanical circuit with somewhat similar properties is shown in Fig. 232. As the weight W falls, work is done on the flywheel and the velocity increases until the rope is all unwound; the flywheel continues to rotate and now raises the weight, so that work is done by the flywheel until the weight has been lifted to the original position, the same cycle is then repeated. During one half cycle the power is positive or energy is put into the flywheel while during the next half cycle the power is negative or energy is being taken from the flywheel, so that the average power is zero.

243. Examples of Inductive and Non-inductive Circuits.—

The coefficient of self induction $L = \frac{n \phi}{I} 10^{-8}$ so that, to have a

large inductance, a circuit must be linked by a large flux ϕ for a given current I . The inductance of coil *B* Fig. 233 is much greater than that of the duplicate coil *A* because the flux ϕ has been greatly increased by the addition of the iron core *C*.

One form of adjustable inductance is shown in Fig. 234. If the iron cross piece *mn* is brought nearer to the poles *pq*, the

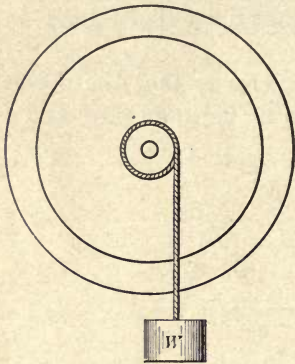

FIG. 232.

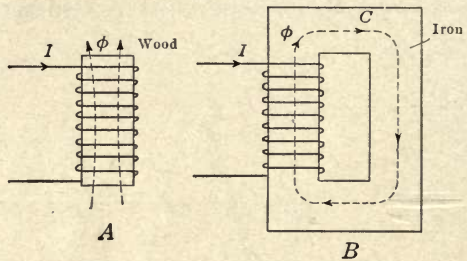

FIG. 233.—Inductive circuits.

reluctance of the magnetic circuit is decreased, so that a larger flux ϕ is produced by a given current I and the inductance is thereby increased.

An incandescent lamp filament has an inductance which is negligible compared with its resistance. The number of turns

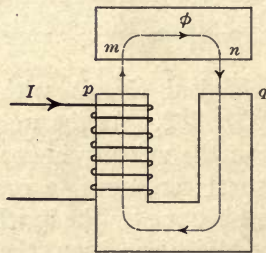
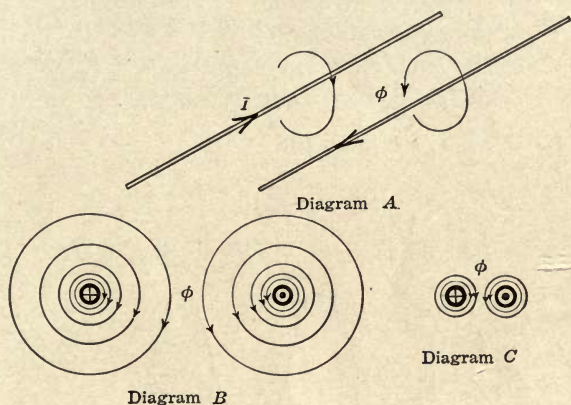

FIG. 234.—Adjustable inductance.

linked is small, while the flux ϕ has to pass through a path containing no iron and moreover is produced by an exciting coil having only two or three turns, so that ϕ is small and $L = (n\phi/I)10^{-8}$ is negligible. The resistance on the other hand is high, that of a 16 candle-power carbon lamp being about 200 ohms.

While a transmission line has only one turn, its inductance is not negligible because that one turn is very long and is linked by a large flux ϕ particularly if the wires are spaced far apart because then, as shown in Fig. 235, there is room for a large flux to pass between the wires.



Wires far apart. Wires close together.
FIG. 235.—Flux linking a transmission line.

A simple long loop such as that in Fig. 236 has a negligible inductance because there is no room for flux to pass between the wires. Non-inductive resistances are made in the form of a long narrow loop and are then coiled up for convenience as shown

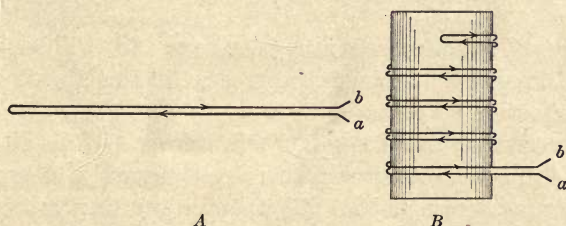

FIG. 236.—Non-inductive resistance.

in diagram B. The resistance between a and b may be large, but the inductance is negligible.

244. Voltage, Current and Power in Resistance Circuits.—If an alternating voltage is applied to a non-inductive circuit of resistance R then, since there is no e.m.f of self induction opposing the change of current, the current i at any instant = e/R

and increases and decreases with the voltage, or is in phase with the voltage, as shown in Fig. 237.

The power in such a circuit is zero at the instants a, b, c and d when both voltage and current are zero but is positive at all other instants, that is energy is put into the circuit but none is taken out again. The average power

$$\begin{aligned}
 &= \text{the average value of } ei \\
 &= \text{the average value of } E_m \sin \theta \times I_m \sin \theta \\
 &= E_m I_m (\text{average value of } \sin^2 \theta) \\
 &= \frac{E_m I_m}{2}, \text{ see page 198} \\
 &= \frac{E_m}{\sqrt{2}} \times \frac{I_m}{\sqrt{2}} \\
 &= EI \text{ and is also } = I^2 R \text{ since } E = IR
 \end{aligned}$$

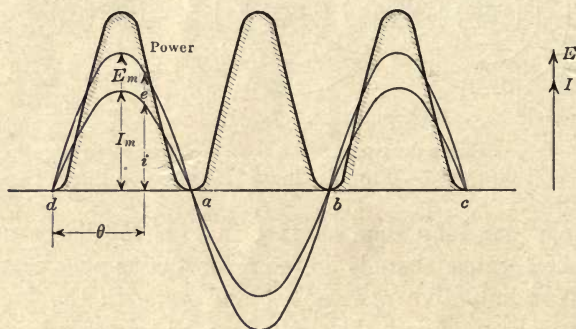

FIG. 237.—Voltage e , current i and power $e \times i$ in a resistance circuit.

where E and I are effective values, see page 198. Thus, in a non-inductive circuit, the power is the product of the effective voltage and the effective current.

245. Resistance and Inductance in Series.—If an alternating current I is flowing in a circuit with a resistance R and a reactance X in series, as shown in Fig. 238, then alternating voltages $E_r = IR$ and $E_x = IX$ will be found across the two parts of the circuit. The applied voltage E is the vector sum of the two components E_r and E_x and may be determined as follows:

A vector I is drawn in any direction.

A vector $E_r = IR$ is drawn to scale and in phase with I , see above.

A vector $E_x = IX$ is drawn to scale in such a direction that I lags E_x by 90 degrees, see page 207.

$$\begin{aligned}
 \text{Then } E &= \text{the vector sum of } E_r \text{ and } E_x \\
 &= \sqrt{E_r^2 + E_x^2} \\
 &= \sqrt{(IR)^2 + (IX)^2} \\
 &= I \sqrt{R^2 + X^2}
 \end{aligned}$$

The current now lags the applied voltage by an angle α , as shown by the vectors and by the curves in Fig. 238. The power curve $e \times i$ is also shown from which it may be seen that, although the power is negative during a portion of the cycle yet the average power is positive.

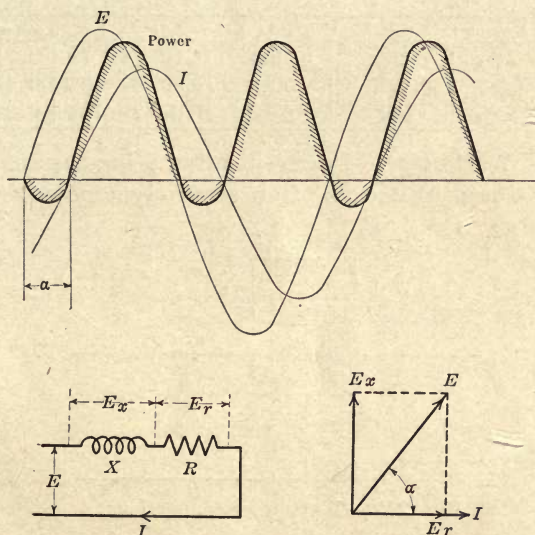

FIG. 238.—Voltage, current and power in a circuit which has resistance and inductance in series.

The voltage E is the resultant of two components one of which $E_r = E \cos \alpha$ is in phase with I while the other component $E_x = E \sin \alpha$ leads I by 90 degrees. The average power due to the in phase component $= (E \cos \alpha) \times I$, see page 212; that due to the other component is zero, see page 209, so that the total average power $= EI \cos \alpha$.

246. The power factor in an alternating-current circuit is defined as the ratio $\frac{\text{actual power}}{\text{apparent power}}$.

In any circuit in which the phase angle between the voltage E and the current I is α degrees then

$$\begin{aligned} \text{the apparent power} &= EI \text{ watts} \\ \text{but the actual power} &= EI \cos \alpha \text{ watts} \\ \text{therefore the power factor} &= \frac{EI \cos \alpha}{EI} \\ &= \cos \alpha \end{aligned}$$

and can never be greater than unity.

If a resistance of 25 ohms and an inductive reactance of 50 ohms at 60 cycles are put in series across 110 volts; find the current, the voltages across the two parts of the circuit and the power in the circuit at 30, 60 and 120 cycles.

The work is carried out in tabular form as follows:

Frequency	R ohms	$X = 2\pi fL$	$\sqrt{R^2 + X^2}$	I	E_r	E_x	$\cos \alpha$	Watts
30	25	25	35.4	3.10	78	78	0.71	240
60	25	50	56.0	1.96	49	98	0.44	96
120	25	100	103.0	1.07	27	107	0.24	29

247. The Wattmeter.—Power in alternating-current circuits may be measured by means of an electro-dynamometer type of

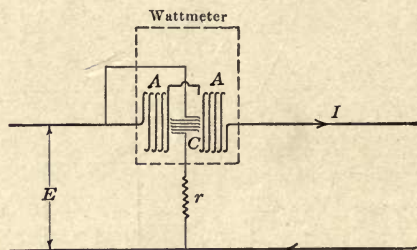

FIG. 239.—Wattmeter connections.

instrument called a wattmeter, constructed as described on page 199, and connected as shown in Fig. 239. The line current I is passed through the stationary coils A , while the current which passes through the moving coil C is proportional to the voltage E and is in phase with it since the inductance of the coil C is negligible compared with the additional resistance r .

Since the moving coil C is carrying current and is in a magnetic field it is acted on by a force tending to turn it about a vertical axis and this force is proportional to the current in the coil and to the strength of the magnetic field. When the instrument is connected as shown in Fig. 239, the magnetic field is proportional to the current I while the current in the moving coil is proportional to the voltage E , and the average turning force is propor-

tional to the average value of $e \times i$ or to $EI \cos \alpha$, the average power in the circuit.

If in the circuit shown in Fig. 239

$$E = 100 \text{ volts}$$

$$I = 50 \text{ amp.}$$

$$W = 4000 \text{ watts, measured by a wattmeter.}$$

$$\begin{aligned} \text{then the power factor of the circuit} &= \frac{\text{actual power}}{\text{apparent power}} \\ &= \frac{4000}{100 \times 50} \\ &= 0.8 \end{aligned}$$

and the phase angle between current and voltage is the angle whose cosine is 0.8 or is 37 degrees.

248. Transmission Line Regulation and Losses.—A transmission line has resistance and inductance and may therefore be

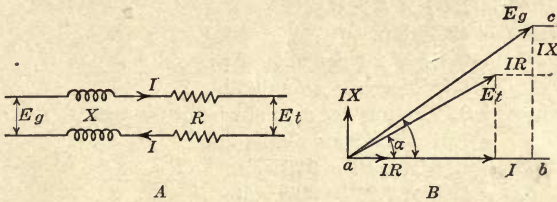

FIG. 240.—Vector diagram for a transmission line.

represented as in Fig. 240. E_g , the voltage at the generating station, is the vector sum of the terminal voltage E_t , the resistance drop IR and the reactance drop IX ; the phase relation between these voltages is shown in diagram *B*.

A vector I is drawn in any direction.

A vector E_t is drawn to scale equal to the receiver voltage, the angle α depending on the resistance and inductance of the load connected to the line;

A vector $E_r = IR$ is drawn to scale in phase with I .

A vector $E_x = IX$ is drawn to scale in such a direction that I lags E_x by 90 degrees.

The vector E_g is the vector sum of E_t , E_r and E_x and may be scaled off or determined by calculation.

Since there is no power loss in the inductance of the line, the total loss is in the resistance and is equal to I^2R watts.

Values of line resistance and line reactance are generally given in ohms per mile as in the following table:

Size of wire		Resistance Ohms per mile of wire	Inductive reactance per mile of wire at 60 cycles			
B. and S. gauge	Cir. mils		24"	48"	72"	96" spacing in inches
0000	211600	0.258	0.594	0.678	0.728	0.763
000	167800	0.326	0.608	0.692	0.742	0.776
00	133100	0.411	0.622	0.706	0.756	0.790
0	105500	0.518	0.637	0.721	0.770	0.804
1	83690	0.653	0.650	0.735	0.784	0.819
2	66370	0.824	0.665	0.749	0.797	0.833
4	41740	1.309	0.693	0.777	0.826	0.860
6	26250	2.082	0.721	0.805	0.854	0.889

75 kw. at 2200 volts and 60 cycles has to be delivered at the end of a 5-mile line, the size of wire being No. 0 B. and S. gauge and the spacing 48 in. Find the voltage in the generating station and the power loss in the line if the load current is lagging and the power factor is 0.8.

$$\text{watts} = E_t \times I \times \cos \alpha, \text{ see page 214,}$$

$$\text{or } 75 \times 1000 = 2200 \times I \times 0.8$$

$$\text{and the current} = 42.5 \text{ amp.}$$

$$\begin{aligned} \text{the resistance} &= 0.518 \text{ ohms per mile of wire} \\ &= 5.18 \text{ ohms for a 5-mile line} \end{aligned}$$

$$\begin{aligned} \text{the reactance} &= 0.721 \text{ ohms per mile of wire at 60 cycles} \\ &= 7.21 \text{ ohms for a 5-mile line} \end{aligned}$$

$$IR = 42.5 \times 5.18 = 220 \text{ volts}$$

$$IX = 42.5 \times 7.21 = 307 \text{ volts}$$

$$ab, \text{ Fig. 240} = (2200 \times 0.8) + 220 = 1980$$

$$bc, \text{ Fig. 240} = (2200 \times 0.6) + 307 = 1627$$

$$\begin{aligned} E_g &= \sqrt{(ab)^2 + (bc)^2} = \sqrt{1980^2 + 1627^2} \\ &= 2560 \text{ volts} \end{aligned}$$

$$\text{the power factor at the generating station} = \frac{cb}{ac} = \frac{1980}{2560} = 0.775$$

$$\text{the power put into the line} = 2560 \times 42.5 \times 0.775 = 84.4 \text{ kw.}$$

$$\text{the power delivered} = 75 \text{ kw.}$$

$$\text{the loss in the line} = 84.4 - 75 = 9.4 \text{ kw.}$$

$$\text{and this is equal to } I^2 R = (42.5)^2 \times 5.18 = 9.4 \text{ kw.}$$

249. Resistance and Inductance in Parallel.—If an alternating voltage E is applied to a circuit which has a resistance R and a reactance X in parallel, as shown in Fig. 241, then a current $I_r = E/R$ will flow through the resistance and will be in phase with E while a current $I_x = E/X$ will flow through the reactance and will lag E by 90 degrees.

These two currents are drawn to scale in diagram B and the total current I is the vector sum of I_r and I_x and

$$I = \sqrt{I_r^2 + I_x^2}$$

If a resistance of 25 ohms and an inductive reactance of 50 ohms at 60 cycles are put in parallel across 110 volts, find the current in each part of the circuit and also the total current at 30, 60 and 120 cycles.

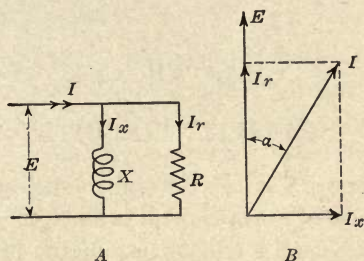

FIG. 241.—Vector diagram for a parallel circuit.

The work is carried out in tabular form as follows:

Frequency	R ohms	$X = 2\pi fL$	I_r	I_x	I	$\cos \alpha$	Watts
30	25	25	4.4	4.4	6.20	0.710	485
60	25	50	4.4	2.2	4.93	0.890	485
120	25	100	4.4	1.1	4.56	0.965	485

CHAPTER XXX

CAPACITY CIRCUITS

250. Condensers.—Two conducting bodies separated by insulating material form what is known as an electrostatic condenser. In diagram A, Fig. 242, *a* and *b*, two plates of a condenser, are at the same potential. When the switch *k* is closed a momentary current *i* passes in the direction of the arrows in diagram B and the condenser is said to be charged; the potential of plate *a* is raised to that of the positive line terminal, the potential of plate *b* is lowered to that of the negative line terminal and the difference of potential between the plates becomes equal to the line voltage.

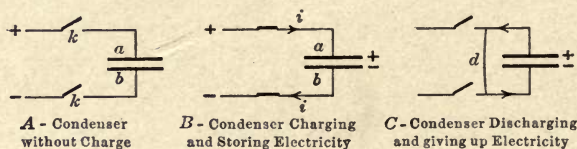

FIG. 242.—Charge and discharge of a condenser.

If the switch *k* is now opened, the voltage between the plates remains unchanged and a quantity, or charge, of electricity remains stored in the condenser.

To make the condenser give up its charge, the insulated plates must be connected by a conducting material, such as the wire *d* in diagram C, so as to bring them to the same potential. When this is done, a momentary current passes in the direction shown, from the positive to the negative plate.

The quantity of electricity stored in a condenser, called the charge, is equal to the average current flowing into the condenser multiplied by the time during which it flows or is equal to $\int idt$ where *i* is the charging current at any instant. In any condenser this charge is found to be directly proportional to the applied voltage or

$$q = Ce$$

where q is the charge in coulombs (amperes \times seconds)

e is the applied voltage

C is a constant called the capacity of the condenser and is expressed in farads.

A condenser of 1 farad capacity will hold a charge of 1 coulomb if a difference of potential of 1 volt is applied between the plates.

The capacity of a condenser of given dimensions is found to depend on the insulating material, or dielectric, between the plates. If a condenser with air as dielectric has a capacity of F farads then the capacity becomes equal to kF farads when another dielectric is used. The constant k is called the specific inductive capacity of the material. Average values of k are given in the following table for the materials generally used in commercial condensers.

Material	Specific inductive capacity
Air	1
Glass	4 (varies considerably with the quality of the glass)
Mica	6
Paraffined paper	2

251. Capacity Circuits with Direct and with Alternating Currents.—A capacity circuit is one which contains a condenser.

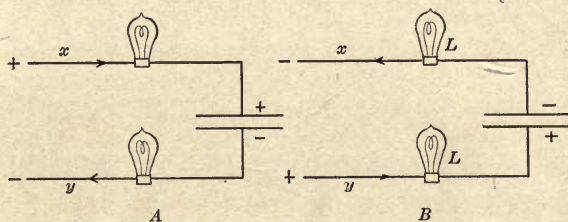

FIG. 243.—Flow of current in a capacity circuit.

If a constant e.m.f. is applied across the terminals of the circuit shown in Fig. 243, then a momentary current will flow in the direction shown in diagram A to charge the condenser but current will not flow continuously since the circuit is broken by the insulating material between the plates.

If the applied voltage is now reversed, current will flow in the direction shown in diagram B until the condenser has given up its charge, and will continue to flow in this direction until the condenser is re-charged in the opposite direction. If then the applied voltage is alternating, a charging current will flow in and

out of the wires x and y with a frequency which is the same as that of the applied voltage, and the lamps L will light up if sufficient current flows to heat the filaments.

The greater the capacity of a condenser, the more electricity it can hold, and the larger the charging current that passes through the connecting wires. Furthermore, the greater the frequency of the applied voltage, the shorter the time available in which to charge the condenser, and therefore the larger the current that must flow. With a given applied alternating voltage, and therefore with a definite alternating charge (since $q = C\epsilon$), the alternating current i is proportional to the capacity and to the frequency or

$$i = \text{a const.} \times C \times f$$

the constant will be determined later.

252. Phase Relation between Voltage and Current in Capacity Circuits.—If the voltage applied to the condenser in Fig. 244 be represented by curve E then the charge, which is proportional to the voltage, is represented by the curve Q ; the condenser is

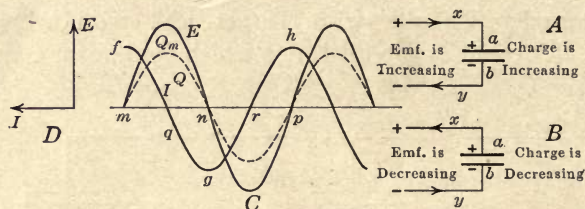

FIG. 244.—Phase relation between the voltage and current in a capacity circuit.

charged alternately in opposite directions, thus between the instants m and n the plate a is positive while between n and p the plate a is negative.

At the instants q and r the charge in the condenser is not changing, the currents in the leads x and y must therefore be zero.

Between m and q the voltage and the charge are increasing and current flows in the positive direction, from the positive to the negative terminal as shown in diagram A, until, at the instant q , the charge is complete and the current has become zero; this gives the part f q of the current curve, see diagram C.

Between q and n the voltage and the charge are decreasing so that current must now be flowing out of the condenser or in the

negative direction as shown in diagram B; this gives the part qg of the current curve.

During the next half cycle between n and p the condenser charges and discharges in the opposite direction, so that the current curve gh is the same as the curve fg except that the sign is reversed.

From these curves it may be seen that the current leads the voltage by 90 degrees.

In the above discussion of phase relation between current and voltage in capacity circuits it is assumed that the current has been flowing for a few seconds. It is obvious that, at the instant the switch in a circuit is closed, the current in that circuit must be zero no matter what value the e.m.f. may have, so that the current waves are generally abnormal for a few cycles after the closing of the switch, but they gradually change and become regular waves leading the e.m.f. by 90 degrees.

253. Voltage and Current Relations in Capacity Circuits.—The charge in the condenser shown in Fig. 244 changes from zero to $Q_m = CE_m$ coulombs in the time of one-quarter of a cycle, or in $1/4f$ seconds, so that, since charge = average current \times time,

$$\text{therefore } Q_m = CE_m = I_{av} \times \frac{1}{4f}$$

and I_{av} , the average charging current = $4fCE_m$ amp.

Now the maximum charging current $I_m = I_{av} \times \frac{\pi}{2}$, see page 197.

$$\begin{aligned} &= \frac{\pi}{2} \times 4fCE_m \\ &= 2\pi fCE_m \end{aligned}$$

therefore I , the effective current in a capacity circuit

$$= 2\pi fCE \text{ where } E \text{ is the effective voltage.}$$

The physical meaning of this equation was explained on page 220.

In direct-current circuits $E = IR$; in capacity circuits $E = IX$ where X , called the capacity reactance, is expressed in ohms and is numerically equal to $\frac{1}{2\pi fC}$

An alternating e.m.f. of 110 volts sends 2.2 amp. through a capacity circuit at 60 cycles. Find the reactance at 60 cycles and find also the capacity of the condenser.

$$X, \text{ the reactance} = \frac{E}{I} \\ = 110/2.2 = 50 \text{ ohms.}$$

$$C, \text{ the capacity} = \frac{1}{2\pi f X} \\ = \frac{1}{2\pi 60 \cdot 50} = 5.3 \times 10^{-5} \text{ farads} = 0.53 \text{ microfarads.}$$

If the voltage applied to the above circuit is kept constant at 110, find the current that will flow through the capacity at 30, 60, 90 and 120 cycles.

$$X, \text{ the reactance} = \frac{1}{2\pi f C} = 50 \text{ ohms at 60 cycles, from last problem} \\ = 100 \text{ ohms at 30 cycles} \\ = 33.3 \text{ ohms at 90 cycles} \\ = 25 \text{ ohms at 120 cycles}$$

$$I, \text{ the current} = E/X = 110/100 = 1.1 \text{ amp. at 30 cycles} \\ = 110/50 = 2.2 \text{ amp. at 60 cycles} \\ = 110/33.3 = 3.3 \text{ amp. at 90 cycles} \\ = 110/25 = 4.4 \text{ amp. at 120 cycles}$$

254. Parallel Plate Condenser.—As shown in the last problem, a condenser with a capacity of 0.53 microfarads will take a cur-

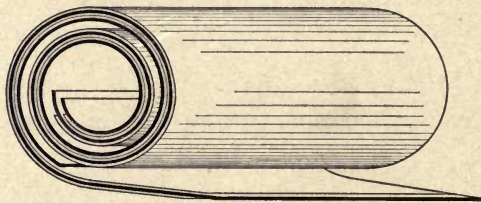

FIG. 245.—One method of constructing condensers.

rent of 2.2 amp. at 110 volts and 60 cycles. It is desirable to know the approximate dimensions of such a condenser.

The capacity of a parallel plate condenser is given by the formula

$$C \text{ in farads} = \frac{1}{4\pi} \times \frac{1}{9 \times 10^{11}} \times \frac{kA}{t}$$

where A is the area of the active surface of one plate in sq. cm.

t is the distance between plates in cm.

k is the specific inductive capacity, see page 219.

A condenser constructed as in Fig. 245 has plates of tin foil which are 40 ft. long and 3 in. wide and are separated by paraffined paper 0.0025 in. thick. Since both sides of each plate are active,

$$A = 2 \times 40 \times 12 \times 3 = 2,880 \text{ sq. in.} \\ = 18,600 \text{ sq. cm.}$$

$$t = 0.0025 \text{ in.} = 0.0063 \text{ cm.}$$

$$k = 2.0$$

$$\begin{aligned} \text{therefore } C \text{ in farads} &= \frac{1}{4\pi} \times \frac{1}{9 \times 10^{11}} \times \frac{18600}{0.0063} \times 2 \\ &= 0.53 \times 10^{-6} \text{ farads} \\ &= 0.53 \text{ microfarads} \end{aligned}$$

Such a condenser will go into a tin case 1.75 in. square by 4 in. deep.

255. Power in Capacity Circuits.—The power in a circuit at any instant is the product of e and i the voltage and the current at that instant. In a capacity circuit the current leads the applied voltage by 90 degrees and the curves representing e , i and ei are shown in Fig. 246. This latter curve is obtained by multiplying together corresponding values of e and i at different instants;

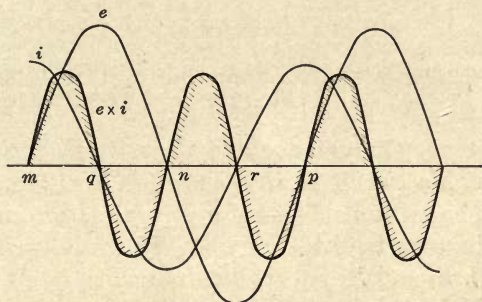

FIG. 246.—Voltage e , current i and power $e \times i$ in a capacity circuit.

at m and n the voltage and therefore the power are zero; the power is also zero at instants q and r when the current is zero. Between m and q energy is stored in the condenser while between q and n the same energy is given up by the condenser, so that the average value of the energy used is zero and so also is the average power in the circuit.

256. The Formulæ used in Circuit Problems are :

Resistance Circuit :

$$E = IR$$

current is in phase with voltage, see page 211

power = EI watts.

Circuit with Inductive Reactance :

$$E = IX \text{ where } X = 2\pi fL, \text{ see page 208}$$

current lags voltage by 90 degrees, see page 207

power is zero.

Circuit with Capacity Reactance :

$E = IX$ where $X = \frac{1}{2\pi fC}$, see page 221

current leads voltage by 90 degrees, see page 220

power is zero.

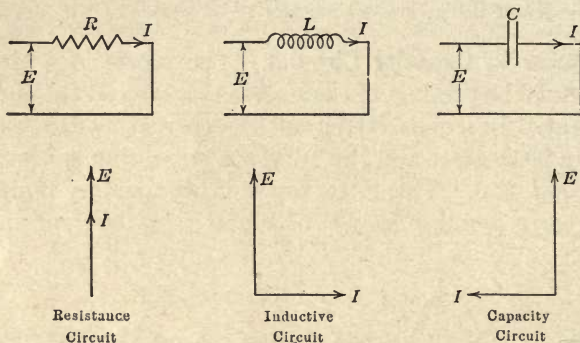

FIG. 247.

257. Resistance, Inductance and Capacity in Series.—In the solution of such a circuit as that shown in Fig. 248, the current vector has to be taken as a basis for phase relation since it is the same in all three parts of the circuit. The voltage E is the vector sum of E_r , E_l and E_c and is determined as follows:

A vector I is drawn in any direction.

A vector $E_r = IR$ is drawn to scale in phase with I .

A vector $E_l = IX_l$ is drawn to scale in such a direction that I lags E_l by 90 degrees.

A vector $E_c = IX_c$ is drawn to scale in such a direction that I leads E_c by 90 degrees.

Then $E =$ the vector sum of E_r , E_l and E_c

$$\begin{aligned} &= \sqrt{E_r^2 + (E_l - E_c)^2} \\ &= \sqrt{(IR)^2 + (IX_l - IX_c)^2} \\ &= I \sqrt{R^2 + (X_l - X_c)^2} \end{aligned}$$

and the current will lead or lag the applied voltage according as X_c is greater or less than X_l .

When $X_c = X_l$ the capacity and the inductive reactances exactly neutralize one another and the current has its maximum value and is equal to E/R . The circuit is then said to be in resonance.

The inductive reactance X_l is directly proportional to the frequency and is equal to $2\pi fL$ whereas the capacity reactance X_c is inversely proportional to the frequency and is equal to $1/2\pi fC$. If then in Fig. 248, the voltage E across the terminals is kept constant and the frequency is increased, X_l will increase and X_c will decrease until when

$$X_l = X_c$$

or
$$2\pi fL = \frac{1}{2\pi fC}$$

and
$$f = \frac{1}{2\pi \sqrt{LC}}$$

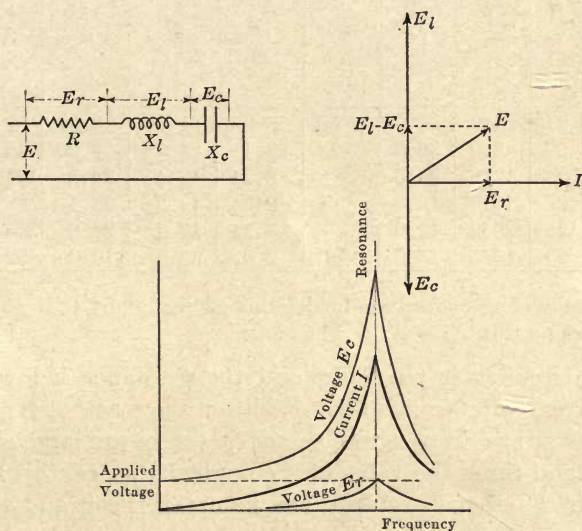

FIG. 248.—Voltage and current in a circuit with resistance R , inductive reactance X_l and capacity reactance X_c in series.

the circuit is said to be in resonance and the current has its maximum value.

The same problem is found in mechanics. An alternating force applied to a spring will cause the spring to oscillate. As the frequency of the applied force increases, the amplitude increases and reaches its maximum value when the applied frequency is the same as the natural frequency of vibration of the spring; with further increase of the frequency, the amplitude will decrease. This principle is made use of in the instrument shown in Fig. 215.

The frequency $f = \frac{1}{2\pi\sqrt{LC}}$ is called the frequency of resonance and is also called the natural frequency of the circuit.

If a resistance of 2 ohms, an inductive reactance of 12 ohms at 60 cycles and a capacity reactance of 20 ohms at 60 cycles are put in series across 110 volts plot the current I and also the voltages E_r , E_l and E_c against frequency.

Several points for these curves are determined as follows:

Frequency	R	$X_l = 2\pi fL$	$X_c = \frac{1}{2\pi fC}$	$(X_l - X_c)$	$\sqrt{R^2 + (X_l - X_c)^2}$	$I = \frac{E}{\sqrt{R^2 + (X_l - X_c)^2}}$	$E_r = IR$	$E_l = IX_c$	$E_c = IX_c$
20.0	2	4.0	60.0	-56	56+	1.97	3.94	7.9	118
40.0	2	8.0	30.0	-22	22.1	4.98	9.96	40.0	150
60.0	2	12.0	20.0	-8	8.24	13.4	26.8	161.0	268
80.0	2	16.0	15.0	1	2.24	49.2	98.4	788.0	738
100.0	2	20.0	12.0	8	8.24	13.4	26.8	268.0	161
77.5	2	15.5	15.5	0	2.0	55.0	110.0	852.0	852

the frequency of resonance can be determined readily by trial and is 77.5 cycles, because then $X_l = X_c = 15.5$ ohms.

If the circuit is in resonance and the resistance is low then a large current will flow, and if in addition the reactances are large then the voltage drops across these reactances are large and may have several times the value of the applied voltage, this result is shown in the above problem; the inductance coil and the condenser must be insulated to withstand 852 volts and not merely the applied 110 volts.

In a circuit which contains only resistance, $E = IR$

in a circuit which contains only inductance, $E = IX_l$

in a circuit which contains only capacity, $E = IX_c$

in a circuit which contains all three in series, $E = IZ$

where Z , called the impedance of the circuit $= \sqrt{R^2 + (X_l - X_c)^2}$

258. Resistance, Inductance and Capacity in Parallel.—In the solution of such a circuit as that shown in Fig. 249, the voltage vector has to be taken as a basis for phase relation since it is the same for all three parts of the circuit. The current I is the vector sum of I_r , I_l and I_c and is determined as follows:

A vector E is drawn in any direction.

A vector $I_r = E/R$ is drawn to scale in phase with E .

A vector $I_l = E/X_l$ is drawn to scale and lagging E by 90 degrees.

A vector $I_c = E/X_c$ is drawn to scale and leading E by 90 degrees.

Then I = the vector sum of I_r , I_l and I_c

$$\begin{aligned}
 &= \sqrt{I_r^2 + (I_l - I_c)^2} \\
 &= \sqrt{(E/R)^2 + (E/X_l - E/X_c)^2} \\
 &= E\sqrt{\left(\frac{1}{R}\right)^2 + \left(\frac{1}{X_l} - \frac{1}{X_c}\right)^2}
 \end{aligned}$$

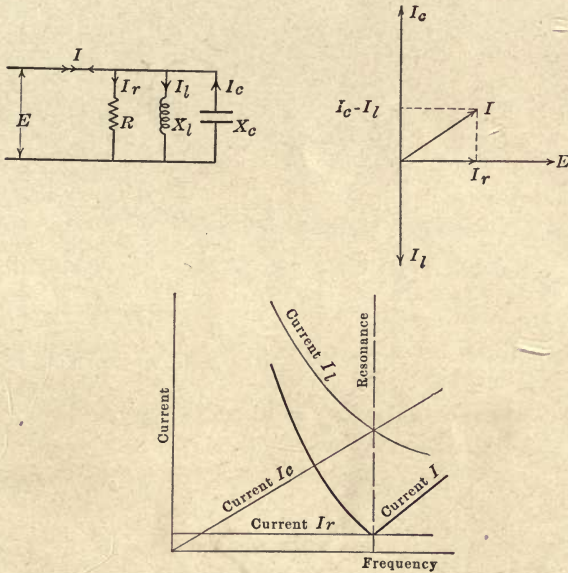

FIG. 249.—Circuit with resistance, inductance and capacity in parallel.

and the current will lead or lag the applied voltage according as I_c is greater or smaller than I_l .

When the circuit is in resonance, $X_c = X_l$ and the current in the line has its minimum value and is equal to E/R . If the reactances are then low compared with the resistance R , the currents I_l and I_c may be much larger than the line current I as shown in the following example.

If a resistance of 20 ohms, an inductive reactance of 2.4 ohms at 60 cycles and a capacity reactance of 4 ohms at 60 cycles are put in parallel across 110 volts, plot the currents in the different parts of the circuit against frequency.

Several points for those curves are determined as follows:

Frequency	R	$X_l = 2\pi fL$	$X_c = \frac{1}{2\pi fC}$	I_r	I_l	I_c	$I_l - I_c$	I
20.0	20	0.8	12.0	5.5	137	9	128	128+
40.0	20	1.6	6.0	5.5	69	18	51	51.2
60.0	20	2.4	4.0	5.5	46	28	18	18.8
77.5	20	3.1	3.1	5.5	35	35	0	5.5
80.0	20	3.2	3.0	5.5	34	37	- 3	6.2
100.0	20	4.0	2.4	5.5	28	46	-18	18.8

CHAPTER XXXI

ALTERNATORS

259. Alternator Construction.—The essential parts of a revolving field type of alternator are shown in Fig. 250. The

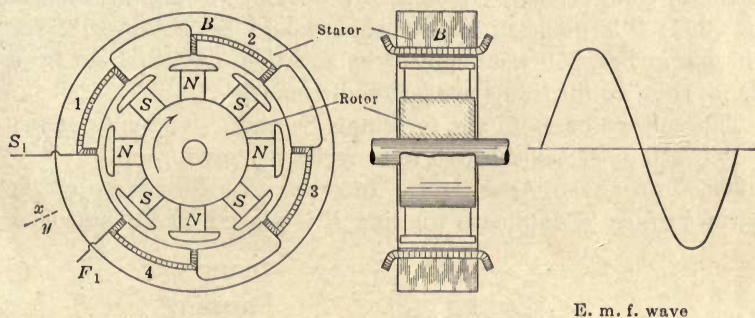

FIG. 250.—Revolving-field type of alternator.

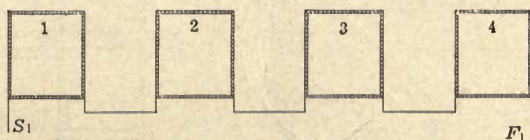

FIG. 251.—Winding diagram.

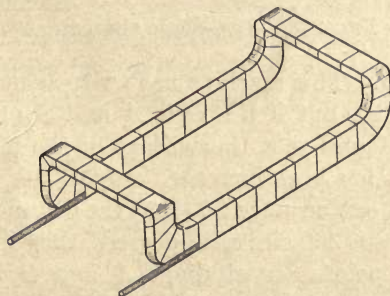

FIG. 252.—Alternator coil.

stationary part which carries the conductors that are cut by the revolving field is called **the stator**; the revolving field system is called **the rotor**.

The stator core B is built up of soft steel laminations and has slots on the inner periphery in which the stator coils are placed. One type of coil is shown in Fig. 252 and consists of several turns of copper wire which are insulated from one another and are then taped up with cotton and other such insulating material. The machine shown in Fig. 250 has four of these coils which are connected in series so that their voltages add up.

Since a connection diagram such as Fig. 250 shows only one end of the machine, it is found desirable in practice to show the coils and connections by means of a developed diagram such as Fig. 251; this diagram shows what would be obtained if the winding in Fig. 250 were split at xy and then flattened out on a plane; the two diagrams are lettered similarly.

The voltage between the terminals S_1 and F_1 varies as shown in Fig. 250 and goes through four cycles per revolution.

260. Two-phase Alternator.—In order to utilize more of the stator surface, a duplicate winding B is placed on the stator as

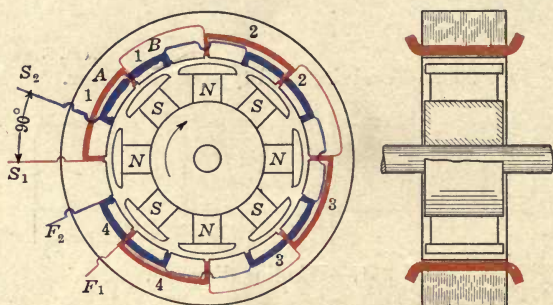

FIG. 253.—Two-phase alternator.

shown in Fig. 253. This machine has twice as many conductors as that in Fig. 250, but if the coils A and B are connected in series, it will be found that the voltage of the machine has not been doubled but has been increased only 41 per cent.

It was pointed out on page 200 that the distance between two adjacent like poles is 360 electrical degrees, therefore the distance between similar points on windings A and B is 90 electrical degrees. If then the voltage generated in the four coils A in series is represented by the curve E_a , Fig. 254, that generated in the four coils B in series has the same magnitude but lags E_a by 90 degrees and is therefore represented by the curve E_b ; when the poles are in the position shown, for example, the voltage in the

winding *A* is a maximum while that in *B* is zero, these values are obtained at the instant *c*, Fig. 254.

The resultant voltage when the two windings are connected in series is the vector sum of E_1 and E_2 and is equal to $\sqrt{2}E = 1.414E$ and if I is the maximum safe current the conductors of the winding can carry then the maximum output is $1.414 EI$ watts. It is therefore desirable to use the two windings *A* and *B* as if they belonged to separate alternators and then, by dividing up the load between them as shown diagrammatically in Fig. 256, each winding can be made to deliver EI watts or the whole machine be made to deliver $2EI$ watts.

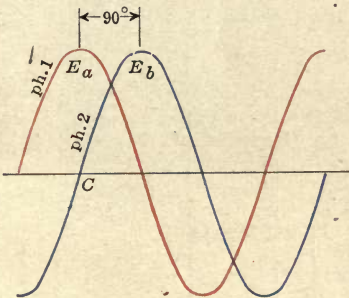

FIG. 254.—Voltage curves of a two-phase alternator.

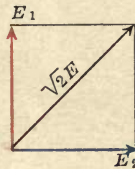

FIG. 255.—Voltage vector diagram for a two-phase alternator.

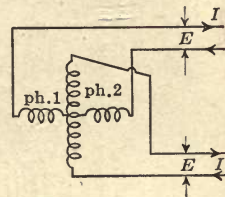

FIG. 256.—Diagrammatic representation of a two-phase alternator.

Since the voltage of winding *B* is out of phase with that of winding *A*, the machine operating as shown in Fig. 253 gives two phases of voltage and is called a two-phase machine, whereas that shown in Fig. 250 is a single-phase machine. The former machine requires four wires for the load while the latter requires only two.

261. Three-phase Alternators.—If three similar and independent single-phase stators are mounted beside one another as in Fig. 257 in such a way that their conductors are cut by the same revolving field, then three separate single-phase e.m.fs. may be obtained, one from each winding. If further these stators are mounted so that S_1, S_2 and S_3 , the starts of the windings of the three phases, are spaced 120 electrical degrees apart, then the e.m.f. in winding *B* will reach a maximum 120 degrees after that in winding *A* has reached its maximum value, and the e.m.f. in winding *C* will lag that in winding *B* by 120 degrees, as shown in Fig. 259.

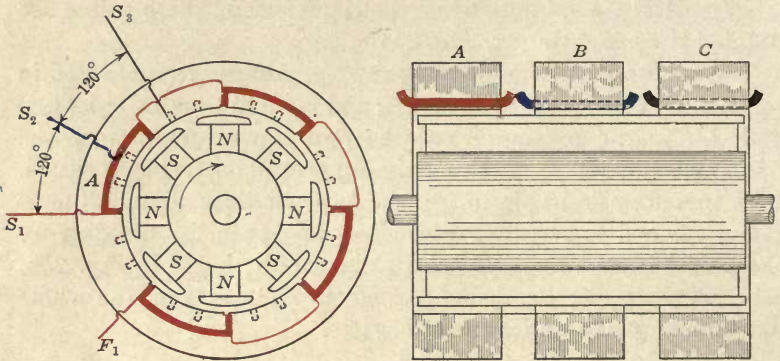

FIG. 257.—Three single-phase stators.

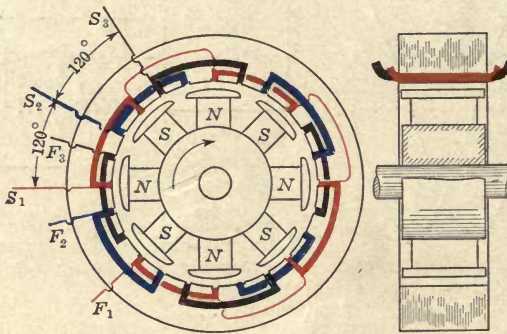

FIG. 258.—Three-phase alternator.

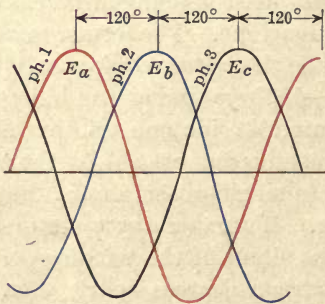

FIG. 259.—Voltage curves of a three-phase alternator.

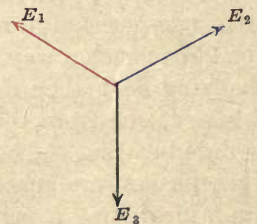

FIG. 260.—Voltage vector diagram for a three-phase alternator.

In practice the three windings are placed on the same core as in Fig. 258, but it must be noted that in the resulting three-phase machine the windings are independent of one another and supply distinct and independent e.m.fs. to three distinct and independent circuits so that the machine is exactly equivalent to three separate single-phase machines and is therefore called a three-phase machine. Part of the winding for such a machine is shown in Fig. 261.

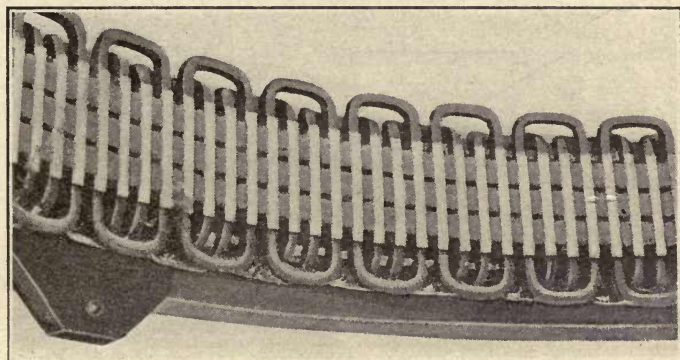

FIG. 261.—Part of the stator of a large three-phase alternator.

262. Y-Connection.—A three-phase machine is conveniently represented by a diagram such as that in Fig. 262, the three vectors in Fig. 260 being replaced by three separate and independent windings; such a machine has six terminals and six leads, two for each phase.

In order to reduce the number of leads, the three return wires a_2 , b_2 and c_2 may be connected together to form a single wire n . The current in this wire at any instant is therefore the sum of i_1 , i_2 and i_3 , the currents in the three phases. But it may be seen from diagram B that, at any instant, the sum of these three currents is zero; at instant a for example i_1 is equal and opposite to $i_2 + i_3$ while at instant b , i_1 is equal and opposite to i_3 and i_2 is zero, the wire n therefore carries no current and may be dispensed with. The resultant connection, shown in Fig. 263, is called the Y-connection and requires only three leads to supply the load, one lead always acting as the return for the other two.

263. Delta-connection.—Another method of connecting the three windings of a three-phase machine is shown diagrammatically in Fig. 264, the windings being connected in series in the

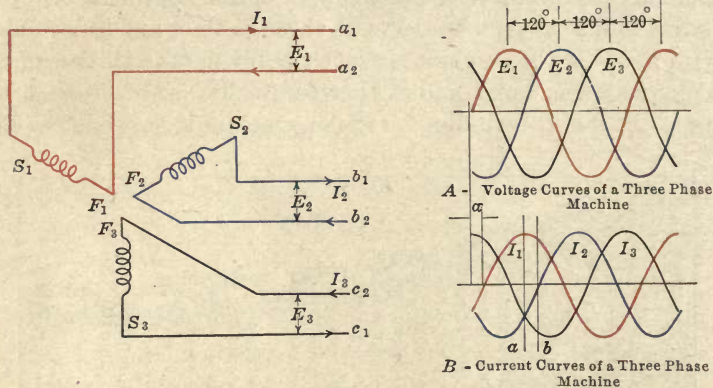

FIG. 262.—Diagrammatic representation of a three-phase machine.

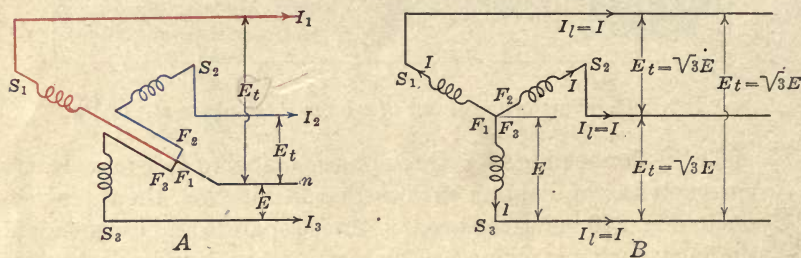

FIG. 263.—Y-Connection.

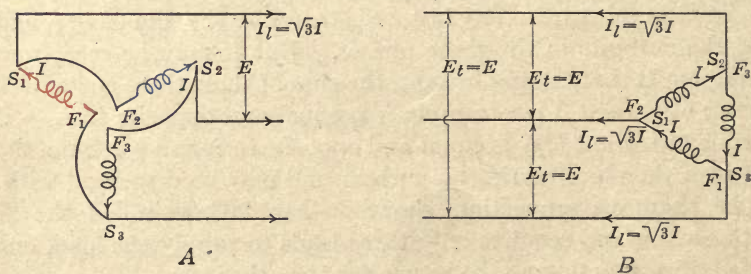

FIG. 264.—Delta-connection.

following order S_1F_2, S_2F_3, S_3F_1 . The wires making these connections may be shortened and the terminals connected directly to one another as shown in diagram B, the slope of the vectors being unchanged. On account of the appearance of this latter diagram, this three-phase connection is called the delta-connection.

Although the winding has been closed on itself, no current flows through this closed circuit. The resultant voltage in the closed circuit is the sum of the voltages in the three phases, but it may be seen from diagram A, Fig. 262, that, at any instant, $e_1 + e_2 + e_3$ is zero, the voltage in one phase being always equal and opposite to the sum of the voltages in the other two phases. If, however, an external circuit is connected between any two leads, then the voltage across that circuit will be E , the voltage of one phase, and current will flow through the circuit.

264. Voltages, Currents and Power in a Y-Connected Machine.

—If two coils S_1F_1 and S_2F_2 are connected as shown in Fig. 265

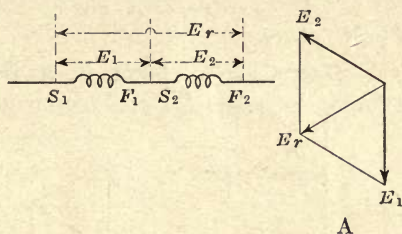
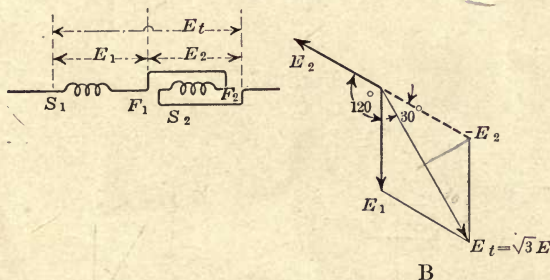

FIG. 265.



B

FIG. 266.—The vector difference between the two voltages E_1 and E_2 , each equal to E , is $E_t = \sqrt{3}E$.

and the voltage E_2 lags E_1 by 120 degrees then the resultant voltage E_r is the vector sum of E_1 and E_2 and may be determined as shown in diagram A.

If, however, the second coil is connected backward as shown in Fig. 266, then the resultant voltage E_t is no longer the vector sum but is the vector difference and is obtained by reversing the

vector to be subtracted and then taking the sum as shown in diagram B, where

$$\begin{aligned} E_t &= 2E \cos 30 \\ &= \sqrt{3}E \\ &= 1.73E \end{aligned}$$

This latter connection is the Y-connection, thus in Fig. 263, F_1 and F_2 are connected together and the voltage between S_1 and $S_2 = 1.73E$. The current I_l in the line is the same as the current I in the winding.

If the current I in each phase of the machine lags the voltage E of that phase by an angle α as shown in diagram B, Fig. 262, then the power in each phase = $EI \cos \alpha$ watts
the power in the three phases = $3EI \cos \alpha$

$$\begin{aligned} &= 3\left(\frac{E_t}{\sqrt{3}}\right)I_l \cos \alpha \\ &= \sqrt{3}E_t I_l \cos \alpha \end{aligned}$$

since $E_t = \sqrt{3}E$ and $I_l = I$.

265. Voltages, Currents and Power in a Delta-connected Machine.—If two coils S_1F_1 and S_2F_2 are connected as shown in

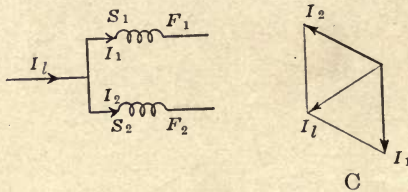

FIG. 267.

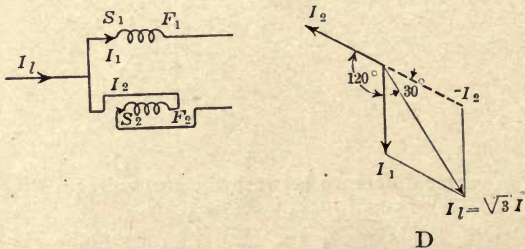

FIG. 268.—The vector difference between the two currents I_1 and I_2 , each equal to I , is $I_l = \sqrt{3}I$.

Fig. 267, and the current I_2 lags I_1 by 120 degrees then the resultant current I_l is the vector sum of I_1 and I_2 and may be determined as shown in diagram C.

-If, however, the second coil is connected backward as shown

in Fig. 268, then the resultant current I_l is no longer the vector sum but is the vector difference as shown in diagram D where

$$\begin{aligned} I_l &= 2I \cos 30 \\ &= \sqrt{3}I \\ &= 1.73I \end{aligned}$$

This latter connection is the delta-connection, thus in Fig. 264, S_1 and F_2 are connected together and the current I_l in the line connected to that point = $1.73I$. The voltage E_l is the same as the voltage E of the winding.

If the current I in each phase of the machine lags the voltage E of that phase by an angle α then

the power in each phase = $EI \cos \alpha$ watts

the power in the three phases = $3EI \cos \alpha$

$$= 3E_l \left(\frac{I_l}{\sqrt{3}} \right) \cos \alpha$$

$$= \sqrt{3} E_l I_l \cos \alpha$$

since $E_l = E$ and $I_l = \sqrt{3}I$

With the same current in the line and the same voltage between lines, the power is the same no matter whether the machine is connected Y or delta.

266. Connection of a Three-phase Load.—The load on a three-phase line may be connected Y as in diagram A, Fig. 269, or

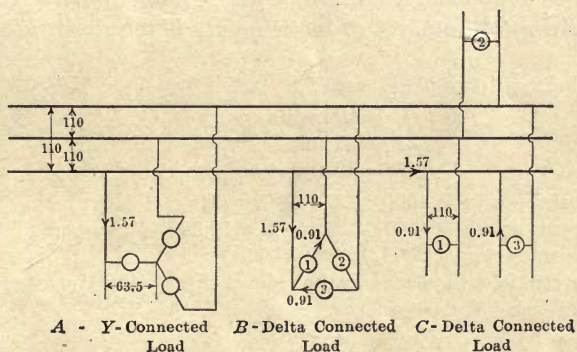

FIG. 269.—Connection of the load to a three-phase circuit.

delta as in diagram B. If the lamps shown are 100-watt lamps then, when Y-connected, the voltage per lamp is $110/\sqrt{3}$ or 63.5 volts and the current per lamp is $\frac{100}{63.5} = 1.57$ amp. When delta connected, 110-volt lamps are required and they take $\frac{100}{110} = 0.91$

amp. The delta-connection is generally used for the connection of individual loads across the phases, the distribution circuits being connected to the power mains as shown in diagram *C*.

If one of the lamps in diagram *B* burns out, the two remaining lamps will burn with their normal brilliancy, but if one of the lamps in diagram *A* burns out, then the two remaining lamps will be in series across 110 volts and will burn dimly since they are then operating at 55 volts instead of at the normal 63.5 volts.

267. Power Measurement in Polyphase Circuits.—A polyphase circuit is one with more than one phase. To measure the

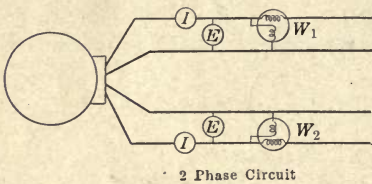

FIG. 270.

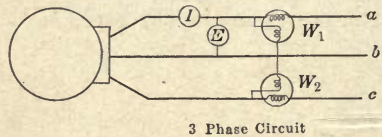

FIG. 271.

FIGS. 270 AND 271.—Wattmeter connections in polyphase circuits.

power in a two-phase circuit, each phase must be considered separately and two wattmeters used as shown in Fig. 270. If the load is balanced, that is divided equally between the two phases, then only one set of instruments is required.

If in a balanced two-phase circuit

$$E = 100 \text{ volts}$$

$$I = 50 \text{ amp.}$$

$$W = 4000 \text{ watts}$$

then the total power = $4000 \times 2 = 8000$ watts

the apparent power = $(100 \times 50) \times 2 = 10,000$ volt amperes

the power factor = $8000/10,000 = 0.8$

and the current in each phase lags the voltage of that phase by an angle whose cosine is 0.8 or by 37 degrees.

In a three-phase circuit it is usually impossible to reach the two leads of each phase and the power has to be measured out on the line where only three leads are available. One line, for example *b*, Fig. 271, is supposed to be the return line for the other two and two wattmeters are connected as shown to measure the power going out on these lines, the total power in the three-phase circuit is the sum of the readings obtained from the two meters.

If in Fig. 271 $E = 100$ volts
 $I = 50$ amp.
 $W_1 = 5000$ watts
 $W_2 = 2500$ watts

then the total power = 7500 watts

the apparent power = $1.73 \times 100 \times 50 = 8650$ volt amperes.

the power factor = $7500/8650 = 86.6$ per cent.

and the current in each phase lags the voltage of that phase by an angle whose cosine is 0.866 or by 30 degrees.

268. Alternator Construction.—The construction of a revolving field type of alternator is shown in Fig. 272.

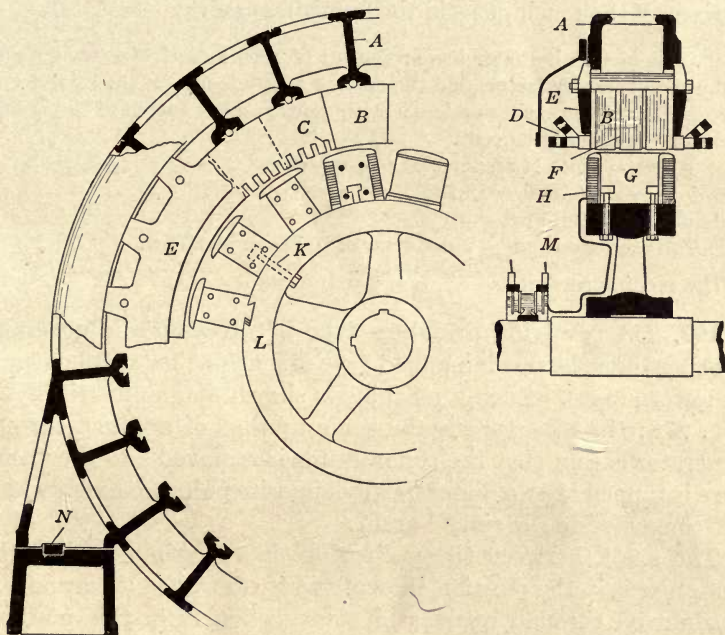

FIG. 272.—Revolving-field type of alternator.

The stator core B is built up of sheet steel laminations which are dovetailed into a cast-iron yoke A and clamped between two iron end heads E . These laminations have slots C on their inner periphery and in these slots are placed the armature conductors D which are insulated from the slots and are connected together to form a winding from which e.m.f. is supplied to an external circuit. The stator core is divided into blocks by means of vent segments F and the ducts thereby provided allow air to circulate freely through the machine and keep it cool.

The rotor or revolving field system consists of a series of N and S poles carrying exciting coils H and mounted on an iron field ring. An alternator has to be excited with direct current, it cannot therefore be self exciting. The exciting current, generally supplied by a small direct-current generator called an exciter, is led into the field coils through brushes M which bear on slip rings insulated from the shaft.

The exciter voltage is independent of that of the alternator and is generally chosen as 120 volts so that, in the case of high-voltage alternators, the exciting current may be larger than the full-load current of the machine as in the following case:

A single-phase alternator has an output of 1000 kw. at 13,200 volts and 100 per cent. power factor, find the current at full-load. If the exciter voltage is 120 and the excitation loss is 2 per cent. find the output of the exciter and also the exciting current.

a. Watts = volts \times amperes \times power factor,
therefore $1000 \times 1000 = 13,200 \times$ amperes $\times 1.0$
and amperes at full-load = 76

b. The exciter output = 2 per cent. of 1000 kw. = 20 kw.

The exciting current = $\frac{20 \times 1000}{120} = 167$ amp.

269. The revolving armature type of alternator is generally cheaper than the revolving field type of machine for small outputs at low voltages. Such a machine is shown diagrammatically in Fig. 273; the armature is the same as that of a direct-current generator except that the commutator is removed and the armature is tapped at two diametrically opposite points m and n which are connected to slip rings 1 and 2.

The e.m.f. between these slip rings is a maximum when the armature is in the position shown, and is zero when the armature has moved through quarter of a revolution from this position because then the voltages generated in the conductors between m and c are opposed by the equal voltages in the conductors between c and n . The e.m.f. again becomes a maximum after the armature has moved through half of a revolution from the position shown in Fig. 273 but the polarity of the slip rings is now reversed. The e.m.f. between the slip rings is therefore alternating and goes through one cycle per pair of poles passed.

If the armature is tapped at four points as shown in Fig. 274, the voltage E_1 between the slip rings 1 and 2 is a maximum when the armature is in the position shown, while the voltage E_2 between the rings 3 and 4 is zero at the same instant, and E_2

lags E_1 by 90 degrees so that the machine is now a two-phase alternator.

To obtain three-phase currents the armature must be tapped at three points as shown in Fig. 275, it then becomes a three phase delta-connected armature. At the instant shown, the

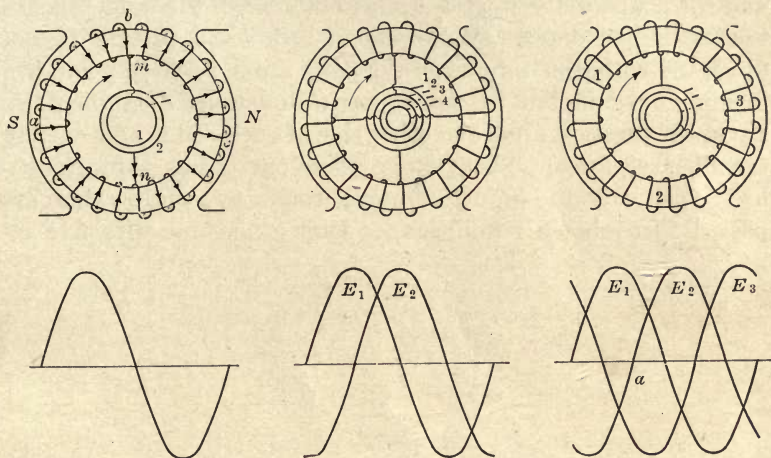

FIG. 273.—Single-phase. FIG. 274.—Two-phase. FIG. 275.—Three-phase.
FIGS. 273–275.—Revolving armature type of alternator.

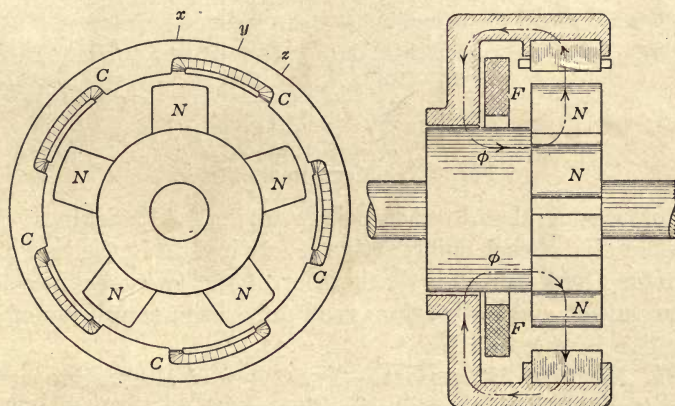

FIG. 276.—Inductor alternator.

voltage E_2 is zero while E_1 is positive and decreasing and E_3 is negative and increasing, this corresponds to instant a on the voltage curve diagram.

270. The inductor alternator, one type of which is shown diagrammatically in Fig. 276, has been found suitable for the gener-

ation of high frequency e.m.fs., because of the simplicity of the mechanical construction.

The stationary field coil F , when excited, produces a magnetic flux ϕ which causes all the inductors N to have the same polarity. The coils C are cut by the lines of force as the inductors rotate, and the generated voltage is a maximum when the inductors are in the position shown and one side of each coil is cutting lines of force, the voltage is zero when the poles are in position y and is a maximum again but in the opposite direction when the poles are in the position z and the other side of each coil is now cutting the lines of force. The voltage therefore passes through one-half cycle while the inductors move from x to z or 10 cycles are passed through per revolution, so that a machine with five in-

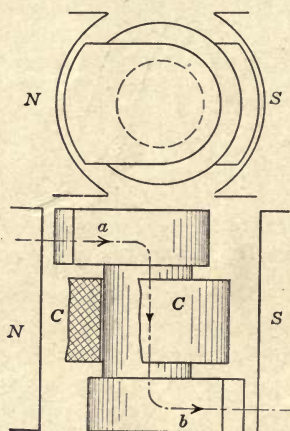

FIG. 277.—Magneto alternator.

ductors is equivalent to a ten-pole revolving field machine. Since only one side of each coil is active at any instant in the case of the inductor alternator, it is the heavier of the two machines for a given output and is therefore used only when simplicity of construction is essential.

271. Magneto Alternators.—Two types of alternating-current magnetos used for gas-engine ignition are shown in Figs. 277 and 278. In the former machine, the armature coil C is stationary and the flux threading this coil is varied by the rotating inductor ab , whereas in the latter machine the coil is wound on the inductor and rotates with it.

In each case, when the inductor is in the position shown, the flux ϕ passes through the coil C from a to b ; half a revolution later

b is under the N pole and a under the S pole and the flux ϕ now passes from b to a and therefore passes through coil C in the opposite direction.

A high peak of e.m.f. is obtained from such machines by shaping the pole faces of the revolving parts so that the flux threading the coil C changes as shown in curve a , Fig. 279; the flux changing very rapidly as the inductor moves from under the poles into the neutral position. The e.m.f. in the coil C , being proportional to the rate of change of the flux, has then its maximum value as shown

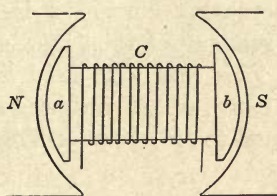

FIG. 278.—Magneto alternator.

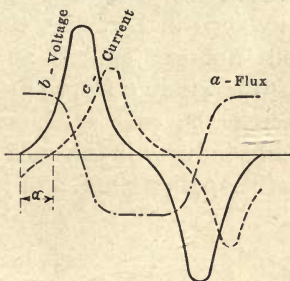

FIG. 279.—Voltage and current curves in a magneto alternator.

in curve b , Fig. 279. The current lags the voltage by an angle α which increases as the reactance of the circuit increases and therefore increases with the frequency of the alternator or the speed of the engine.

CHAPTER XXXII

ALTERNATOR CHARACTERISTICS

272. Armature Reaction.—Part of the winding of an alternator is shown in Fig. 280, the poles being stationary and the field coils not excited. If an alternating current I is passed through this winding from an external source then lines of force will encircle the coils as shown. This magnetic field is alternating and induces in the coils an e.m.f. of self induction which opposes the applied e.m.f. and is equal to IX , see page 208, where

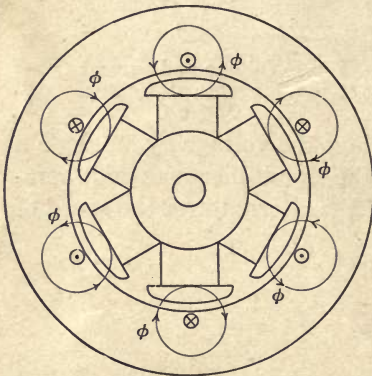

FIG. 280.—Magnetic flux due to the armature current.

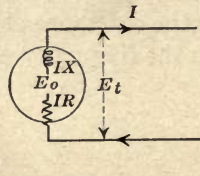

FIG. 281.—Diagrammatic representation of an alternator.

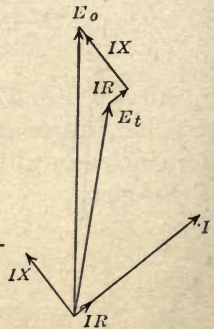

FIG. 282.—Vector diagram for an alternator.

I is the current flowing and X is the reactance of the winding due to its self induction. An alternator may therefore be considered as a circuit with a resistance R and a reactance X as shown diagrammatically in Fig. 281. The value of X is generally from 4 to 10 times the value of R .

If now an alternator is operating under normal conditions, fully excited, generating voltage and supplying current then, of the total voltage generated, a portion IX is required to overcome the

reactance of the winding and another portion IR to overcome the resistance; the terminal voltage E_t is obtained from the generated voltage E_o by subtracting IR and IX as vectors.

273. Vector Diagram at Full-load.—If in Fig. 282, E_o is the voltage generated by an alternator at no-load, and a circuit is then connected across the alternator terminals which takes a current I from the machine, the armature resistance drop IR is in phase with the current while the current lags the armature reactance drop IX by 90 degrees, see page 207, and the terminal voltage E_t is obtained by subtracting IX and IR from E_o as shown in Fig. 282.

Three cases are shown in Figs. 283, 284, and 285, in which an alternator has the same terminal voltage E_t and delivers the same

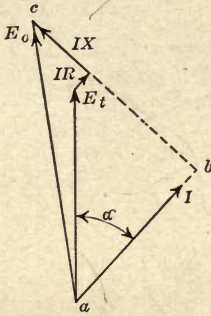

FIG. 283.—Lagging current.

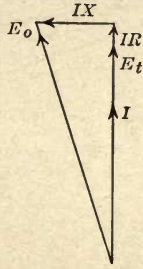

FIG. 284.—100 per cent. power factor.

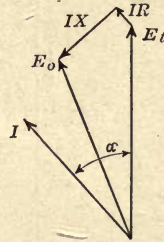

FIG. 285.—Leading current.

FIGS. 283-285.—Effect of the power factor of the load on the regulation of an alternator.

current I , but different circuits are used in the three cases so that the phase angles α are different.

It may be seen from these diagrams that the regulation of an alternator, namely, the ratio $(E_o - E_t)/E_t$, depends largely on the power factor of the load, and becomes negative if the current is leading considerably, as shown in Fig. 285 where E_t is greater than E_o .

274. Regulation Curves of an Alternator.—Since the regulation of an alternator depends on the power factor of the load as well as on the current, the external characteristics have to be given with different power factors as shown in Fig. 286. These curves are generally determined by calculation after the resistance and reactance of the winding have been measured.

A single-phase alternator with an output of 416 amp. at 2400 volts has a resistance of 0.2 ohms and a reactance of 2.3 ohms. Find the regulation at 100 per cent. power factor, and also at 80 per cent. power factor with a lagging current, the full-load voltage being 2400 volts in each case.

Full-load current = 416 amp.

the resistance drop $IR = 416 \times 0.2 = 83$ volts

the reactance drop $IX = 416 \times 2.3 = 960$ volts.

At 100 per cent. power factor, see Fig. 284

$$\begin{aligned} E_o^2 &= (E_t + IR)^2 + (IX)^2 \\ &= 2483^2 + 960^2 \end{aligned}$$

and $E_o = 2660$

$$\text{the regulation} = \frac{E_o - E_t}{E_t} = \frac{260}{2400} = 10.8 \text{ per cent.}$$

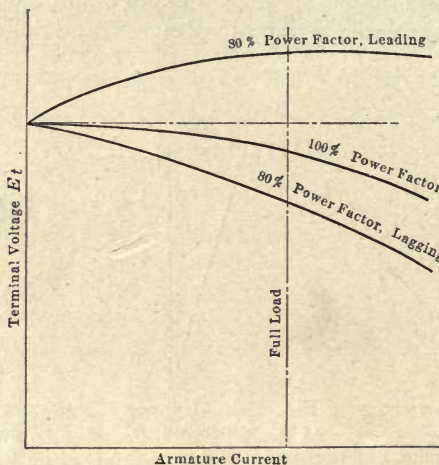

FIG. 286.—Regulation curves of an alternator.

At 80 per cent. power factor with lagging current, see Fig. 283

$$\begin{aligned} E_o^2 &= ab^2 + bc^2 \\ &= (E_t \cos \alpha + IR)^2 + (E_t \sin \alpha + IX)^2 \\ &= (2400 \times 0.8 + 83)^2 + (2400 \times 0.6 + 960)^2 \end{aligned}$$

and $E_o = 3120$

$$\text{the regulation} = \frac{3120 - 2400}{2400} = 30 \text{ per cent.}$$

275. Experimental Determination of Alternator Reactance.—

The no-load saturation curve in Fig. 287 is determined in the same way as for a direct-current generator, see page 70. The alternator is then short-circuited through an ammeter as shown in diagram *B*, and run at normal speed, while simultaneous readings are taken of the armature current I_a and the exciting current I_f from which the short-circuit curve is plotted.

From these two curves the reactance of the alternator may readily be determined. With an exciting current oa for example, the voltage generated by the alternator is $ab = 2400$ volts at no-load. With the same excitation and with the armature short-circuited, the terminal voltage is zero and the generated voltage ab is used up in sending a current $ac = 1040$ amp. through the resistance and reactance of the winding or

$$\text{voltage } ab = \text{current } ac \times \sqrt{R^2 + X^2}$$

$$2400 = 1040 \times \sqrt{R^2 + X^2}$$

and $\sqrt{R^2 + X^2} = 2.3 \text{ ohms}$

from which X may be determined if the value of R is known, and this may readily be measured by passing a direct current I through the alternator winding and measuring the voltage drop E , since $R = E/I$.

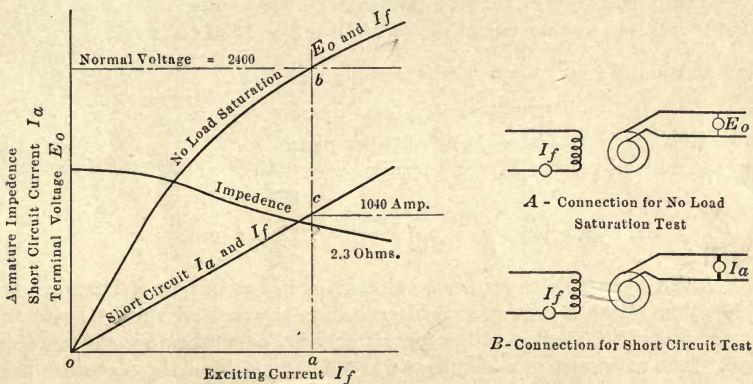

FIG. 287.—Determination of the impedance of an alternator.

It may be seen from Fig. 287 that the reactance X decreases as the magnetic circuit of the machine becomes saturated. The reactance is caused by the flux produced by the armature current, as shown in Fig. 280. When the field coils are excited so that the main flux of the machine is passing through the poles, then a smaller additional armature flux is produced with a given armature current than when the poles are not excited, and a smaller armature flux produces a smaller reactance.

1. A three-phase Y-connected alternator has an output of 240 amp. at 2400 volts. With a certain field excitation the no-load voltage between terminals was 2400 volts and the current in each line on short-circuit was 600 amp. The resistance of each phase is 0.2 ohms. Find the reactance per phase.

$$\begin{aligned}
 E_t, \text{ the terminal voltage at no-load} &= 2400 \text{ volts} \\
 E, \text{ the voltage per phase at no-load} &= 2400/\sqrt{3}, \text{ page 236} \\
 &= 1390 \text{ volts} \\
 I_t, \text{ the line current on short-circuit} &= 600 \text{ amp.} \\
 I, \text{ the current per phase on short-circuit} &= 600 \text{ amp., page 236} \\
 Z, \text{ the impedance per phase} &= \frac{1390}{600} = 2.3 \text{ ohms} \\
 X, \text{ the reactance per phase} &= \sqrt{Z^2 - R^2} \\
 &= \sqrt{2.3^2 - 0.2^2} \\
 &= 2.3 -
 \end{aligned}$$

Find the regulation of this machine at full-load and 100 per cent. power factor, the full-load voltage between terminals being 2400 volts.

$$\begin{aligned}
 \text{Full-load current in line} &= 240 \text{ amp.} \\
 \text{the full-load current per phase} &= 240 \text{ amp.} \\
 \text{the resistance drop } IR \text{ per phase} &= 240 \times 0.2 = 48 \text{ volts} \\
 \text{the reactance drop } IX \text{ per phase} &= 240 \times 2.3 = 550 \text{ volts} \\
 \text{the full-load voltage between terminals} &= 2400 \text{ volts} \\
 \text{the full-load voltage per phase} &= 2400/\sqrt{3} = 1390 \text{ volts}
 \end{aligned}$$

then at 100 per cent. power factor, see Fig. 284

$$\begin{aligned}
 E_o^2 &= (1390 + 48)^2 + 550^2 \\
 \text{and } E_o &= 1540 \text{ volts per phase} \\
 \text{and the no-load voltage between terminals} &= 1540 \times \sqrt{3} \\
 &= 2660 \text{ volts} \\
 \text{the regulation} &= \frac{2660 - 2400}{2400} = 10.8 \text{ per cent.}
 \end{aligned}$$

2. A three-phase delta-connected alternator has an output of 240 amp. at 2400 volts. With a particular field excitation the no-load voltage between terminals was 2400 volts and the current in each line on short-circuit was 600 amp. The resistance of each phase was 0.6 ohms. Find the reactance per phase.

$$\begin{aligned}
 E_t, \text{ the terminal voltage at no-load} &= 2400 \text{ volts} \\
 E, \text{ the voltage per phase at no-load} &= 2400 \text{ volts, page 237} \\
 I_t, \text{ the line current on short-circuit} &= 600 \text{ amp.} \\
 I, \text{ the current per phase on short-circuit} &= 600/\sqrt{3}, \text{ page 237} \\
 &= 346 \text{ amp.} \\
 Z, \text{ the impedance per phase} &= \frac{2400}{346} = 6.9 \text{ ohms} \\
 X, \text{ the reactance per phase} &= \sqrt{6.9^2 - 0.6^2} \\
 &= 6.9 -
 \end{aligned}$$

Find the regulation of this machine at full-load and 100 per cent. power factor, the full-load voltage between terminals being 2400 volts.

$$\begin{aligned}
 \text{Full-load current in the line} &= 240 \text{ amp.} \\
 \text{the full-load current per phase} &= 240/\sqrt{3}, \text{ page 237} \\
 &= 139 \text{ amp.}
 \end{aligned}$$

the resistance drop IR per phase = $139 \times 0.6 = 83$ volts
 the reactance drop IX per phase = $139 \times 6.9 = 960$ volts
 the full-load voltage between terminals = 2400 volts
 the full-load voltage per phase = 2400 volts, page 237
 at 100 per cent. power factor, see Fig. 284,

$$E_o^2 = (2400 + 83)^2 + 960^2$$

$$E_o = 2660 \text{ volts}$$

$$\text{the regulation} = \frac{2660 - 2400}{2400} = 10.8 \text{ per cent.}$$

276. Automatic Regulators.—To maintain the voltage of an alternator constant, the field excitation must be increased as the armature current increases and as the power factor decreases. This cannot be done by adding series field coils as in the case of the direct-current generator, see page 74, because the line current is alternating and not suitable for excitation purposes.

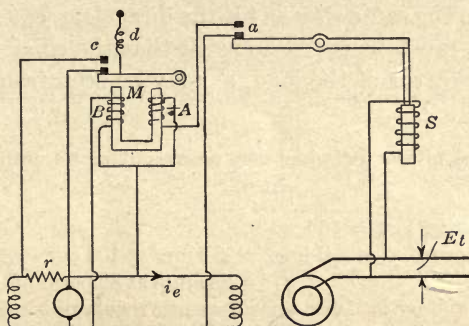

FIG. 288.—Automatic voltage-regulator.

Automatic regulators are used with alternators. The essential parts of such a regulator are shown diagrammatically in Fig. 288. To keep the voltage E_t constant, some means must be provided to close the contact c so as to short-circuit the resistance r and thereby increase the exciter voltage and also the exciter current i_e when the alternator voltage is too low, and to open this contact and insert the resistance r in the exciter field circuit when the alternator voltage is too high.

The contact c is opened by the electromagnet M on which are two opposing windings A and B . When the contact a is open, B alone is excited and opens the contact c against the tension of the spring d , but when a is closed, the coil A also is excited and neutralizes the pull of B and the spring d closes the contact c .

If then the alternator voltage rises, the pull of the solenoid S is

increased and its plunger is raised so as to open the contact *a*, the coil *A* is then deenergized and *B* opens the contact *c* and inserts the resistance *r* in the exciter field circuit. The alternator voltage now drops, the pull of the solenoid *S* decreases, and the weight of the plunger closes the contact *a* and thereby excites coil *A* which neutralizes the pull of *B*, the spring *d* then closes the contact *c* and short-circuits the resistance *r* and thereby increases the field excitation.

When additional attachments are added to this regulator to make it more sensitive, the voltage fluctuations on which the operation of the regulator depends cannot be detected on a sensitive voltmeter.

277. Efficiency.—The losses in an alternator are the same as in a direct-current generator and consist of the stray loss, the armature copper loss, and the field excitation loss. These losses are determined in the same way as for the direct-current machine, see page 97. It must be noted however that the efficiency depends on the power factor of the load, as may be seen from the following example.

In a two-phase alternator which has an output of 83 amp. per phase at 2400 volts

the stray power loss = 16 kw.

the exciting current at full-load = 68 amp. at 100 per cent. power factor
= 85 amp. at 80 per cent. power factor

the exciter voltage is 110 and no automatic regulator is supplied

the resistance of each phase of the armature winding, measured by direct current = 0.4 ohms.

Find the efficiency when the power factor of the load is 100 per cent. and also when 80 per cent.; find also the horse-power of the driving engine.

	at 100 per cent. power factor	at 80 per cent. power factor
The output	$= 2 \times 2400 \times 83$ $= 400 \text{ kw.}$	$= 2 \times 2400 \times 83 \times 0.8$ $= 320 \text{ kw.}$
The stray loss	$= 16 \text{ kw.}$	$= 16 \text{ kw.}$
The excitation loss	$= 110 \times 68$ $= 7.5 \text{ kw.}$	$= 110 \times 85$ $= 9.4 \text{ kw.}$
The armature copper loss	$= (83^2 \times 0.4) \times 2$ $= 5.5 \text{ kw.}$	$= 5.5 \text{ kw.}$
The total loss	$= 29 \text{ kw.}$	$= 30.9 \text{ kw.}$
The input	$= 429 \text{ kw.}$	$= 350.9 \text{ kw.}$
The horse-power of the driving engine	$= 575 \text{ h.p.}$	$= 470 \text{ h.p.}$
The efficiency	$= \frac{400}{429} = 93.4 \text{ per cent.}$	$= \frac{320}{350.9} = 91.4 \text{ per cent.}$

The lower the power factor, the smaller is the power output, and at the same time the greater the excitation loss because of the increase in the exciting current required to maintain the voltage.

278. Rating of Alternators.—An alternator is designed so as to give normal voltage and normal current without overheating, but the output in kilowatts will depend entirely on the power factor of the connected load. It is usual to specify the output at 100 per cent. power factor and then, to emphasize the fact that this output cannot be obtained from the machine at lower power factors, the unit of output is taken as the kilovolt ampere (kv.a.) and not as the kilowatt, where (kv.a. \times power factor) = kw.

A single-phase alternator can give 100 amp. at 2400 volts. What is the output of the machine in kv.a. and also in kw. if the power factor of the load is 80 per cent.

$$\text{kv.a.} = \frac{2400 \times 100}{1000} = 240$$

$$\text{kw.} = 240 \times 0.8 = 192$$

A three-phase alternator can give 100 amp. from each terminal with a voltage between terminals of 2400 then

$$\text{the output in kv.a.} = \frac{1.73 \times 2400 \times 100}{1000}, \text{ see page 236,} = 415$$

at 80 per cent. power factor the output would be $415 \times 0.8 = 332$ kw.

CHAPTER XXXIII

SYNCHRONOUS MOTORS AND PARALLEL OPERATION

279. Principle of Operation of Synchronous Motors.—An alternating-current generator may be made to operate as a motor. When an alternating e.m.f. is applied to the winding of the single-phase machine shown in Fig. 289, an alternating current flows through that winding. The conductors *a*, *b*, *c*, and *d* are then carrying current and are in a magnetic field so that a force acts on each conductor, while an equal and opposite force acts on the poles and tends to turn the rotor. The current however is alternating, so that the force on the rotor is alternating in direction unless the polarity of the poles is changed at the instant the current reverses.

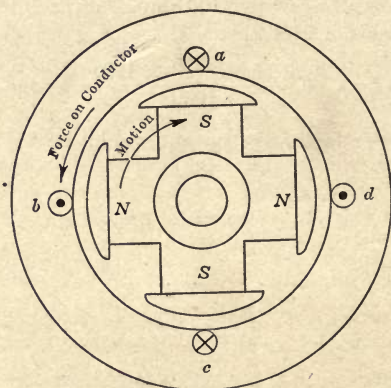

FIG. 289.—The synchronous motor.

This would be the case if the machine was already running at such a speed that, during the time of half a cycle or in $\frac{1}{2f}$ seconds, the rotor moves through the distance between two adjacent poles or through $1/p$ of a revolution. This speed, called the synchronous speed, is therefore equal to

$$\frac{1}{p} \times 2f \text{ rev. per sec.}$$

or

$$\frac{120f}{p} \text{ rev. per min.}$$

and is the speed at which the machine would have to run as an alternator in order to generate an e.m.f. of f cycles per second, see the formula on page 195. The table on page 195 therefore applies to synchronous motors, as this type of machine is called, as well as to alternators. When a synchronous motor is running at synchronous speed it is said to be in step with the alternators driving it.

A synchronous motor is not self starting, but will develop a torque continuously in one direction if running at synchronous speed. Such a machine is generally brought up to speed by a small self-starting motor which is direct connected to the shaft.

280. The Back E.m.f. of a Synchronous Motor.—If the motor M , Fig. 290, is rotating at synchronous speed, then its stator wind-

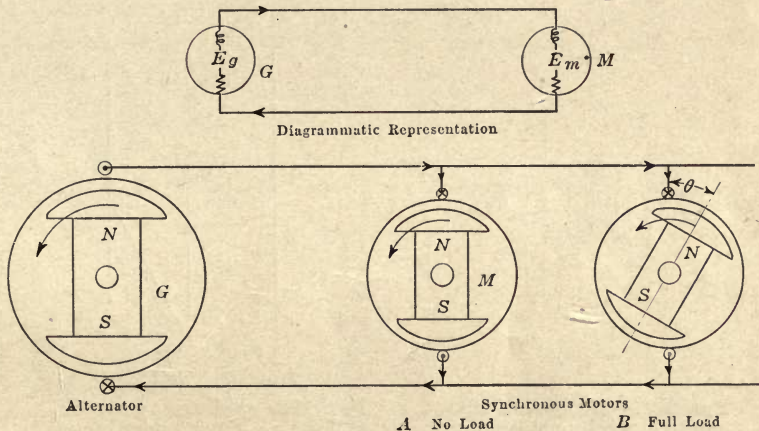

FIG. 290.—Alternator driving synchronous motors.

ing is being cut by lines of force and an e.m.f. is generated in the machine in the same way as if it were driven by an engine. This e.m.f. E_m , called the back e.m.f. of the motor, opposes the applied e.m.f. E_g and is of the same frequency, and, in the case where the two machines are equally excited, then $E_m = E_g$.

If the motor is running on no-load, the load current that it takes from the line is practically zero, being merely sufficient to overcome the friction of the machine, and in such a case E_m is exactly equal and opposite to E_g at every instant as shown by the vectors in Fig. 292, for, under these conditions, there is no resultant e.m.f. and no flow of current through the machines. The poles of the

two machines will then rotate together with the relative position shown in diagram A, Fig. 290.

If now the motor is loaded, it will slow down for an instant and will swing back relative to machine *G* as shown in diagram *B*, Fig. 290. The back e.m.f. E_m , although still equal to E_g is now no longer opposite in phase as at no-load, but lags its no-load value by an angle θ as shown by the vectors in Fig. 292. There is now a resultant e.m.f. E_r which sends a current through the machines, and the torque developed due to this current keeps the motor running at synchronous speed but always with such a lag behind the generator as to allow a current to flow large enough to develop a driving torque equal to the retarding torque of the load. The motor therefore automatically takes from the generator a current corresponding to the mechanical load.

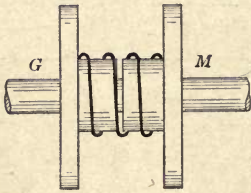
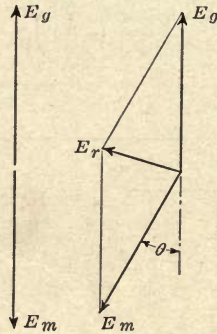

FIG. 291.—Mechanical analogy to a synchronous motor.



No load. Full load.
 FIG. 292.—Voltage vector diagrams for a synchronous motor.

281. Mechanical Analogy.—The transmission of power by means of an alternator and a synchronous motor is similar in many ways to the transmission of power by means of a flexible spring coupling such as that shown in Fig. 291. If the load on the side *M* is increased, the spring stretches and *M* drops back through a small angle relative to *G*, but both continue thereafter to rotate at normal speed.

282. Vector Diagram for a Synchronous Motor.—In Fig. 293 E_g is the e.m.f. generated in the alternator winding.

E_m is the back e.m.f. generated in the motor winding.

E_r , the resultant e.m.f., sends an alternating current I through both machines.

R_m and X_m are the resistance and reactance of the motor winding
 R_g and X_g are the resistance and reactance of the generator winding.

then
$$I = \frac{E_r}{\sqrt{(R_m + R_g)^2 + (X_m + X_g)^2}}$$

and since the resistances are generally small compared with the reactances, see page 244, therefore

$$I = \frac{E_r}{X_m + X_g}$$

Since the circuit is almost entirely inductive, the resistance being negligible, the current I must lag the voltage E_r by 90 degrees.

The power developed by the generator = $E_g I \cos \alpha$.

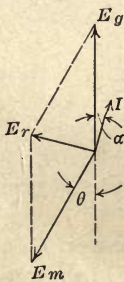
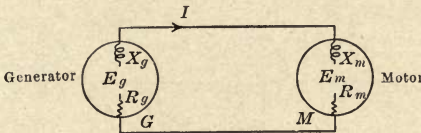

FIG. 293.
Light load.

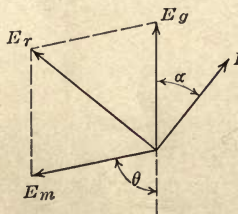

FIG. 294.
Heavy load.

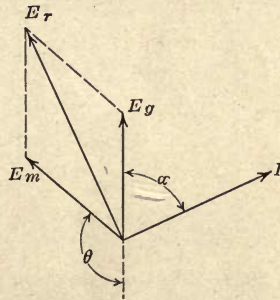

FIG. 295.—Load greater than the maximum output.

FIGS. 293-295.—Vector diagram for the synchronous motor at various loads.

If the load on the motor is now increased, the motor swings back relative to the generator by a greater angle θ , as shown in Fig. 294. The voltage E_r and the current I are now larger than before and so also is $E_g I \cos \alpha$ the power developed by the generator and put into the circuit.

283. Maximum Output.—An extreme case is shown in Fig. 295 where the load has caused the motor to swing back by a large angle θ , but the power put into the line, namely $E_g I \cos \alpha$, is

now less than in the case represented in Fig. 294, so that, while the angle θ increases as the load is increased, the power input $E_g I \cos \alpha$ increases only up to a certain point called the break-down point or point of maximum output. When the load exceeds this value the motor slows down and stops.

The maximum output is generally more than twice the normal output of the machine as fixed by the heating of the windings.

284. Operation of a Synchronous Motor when Under- and Overexcited.—In diagram *B*, Fig. 296, the excitation of the motor *M* is such that $E_m = E_g$. Two other conditions of operation are represented in diagrams *A* and *C*. In the former case the motor is overexcited and, since the speed cannot change but must always be synchronous speed, the voltage E_m must

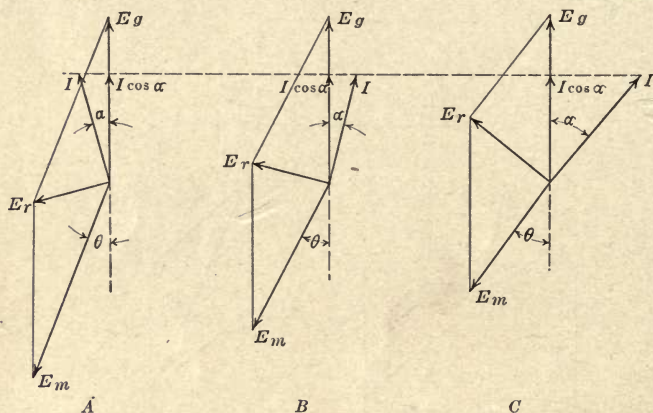

FIG. 296.—Effect of excitation on the power factor of a synchronous motor.

increase with the excitation and must now be greater than E_g . In the latter case the motor is underexcited and E_m must be less than E_g . The load on the motor however is unchanged so that $E_g I \cos \alpha$ is constant.

It is important to note that, in the case of the overexcited motor, diagram *A*, the current I leads the generator voltage E_g , or an overexcited synchronous motor draws a leading current from the line. Now a condenser always draws a leading current, see page 220, so that an overexcited synchronous motor acts to a certain extent like a condenser.

285. Use of the Synchronous Motor for Power Factor Correction.—If the load connected to an alternator has a low power factor, it is often advisable to arrange that some of the load shall be

carried by synchronous motors so as to improve the power factor of the whole system.

If 1000 horse-power of 2200-volt single-phase induction motors are operating at the end of a transmission line, find the current in the line and also the generator capacity required if the average power factor is 80 per cent. and the average efficiency is 90 per cent. (The induction motor, see Chap. 36, takes a lagging current, and its power factor cannot be controlled.)

The output of the motors is 1000 h.p.

$$\begin{aligned} \text{the input to the motors is } & \frac{1000}{0.9} = 1115 \text{ h.p.} \\ & = 830 \text{ kw.} \end{aligned}$$

$$\text{the generator capacity required} = \frac{830}{0.8} = 1040 \text{ kv.a.}$$

$$\text{the current in the line} = \frac{1040 \times 1000}{2200} = 473 \text{ amp.}$$

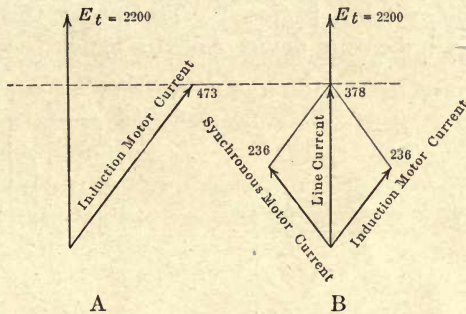

FIG. 297.

If 500 horse-power of the load is driven by a synchronous motor, the power factor of the whole system may be raised if this motor is overexcited and made to act as a condenser.

If the power factor of the synchronous motor be made 80 per cent., with the current leading, then the vector diagram for the load is as shown in diagram B, Fig. 297.

The induction motor output = 500 h.p.

$$\text{the induction motor input} = \frac{500}{0.9} \times \frac{746}{1000} = 415 \text{ kw.}$$

$$\text{the current for these motors} = \frac{415 \times 1000}{2200 \times 0.8} = 236 \text{ amp.}$$

The current for the synchronous motor also is 236 amp., but it leads by an angle whose cosine is 0.8 whereas the current for the induction motor lags by the same angle

$$\begin{aligned} \text{the resultant current in the line} & = 2 (236 \times 0.8) \\ & = 378 \text{ amp.} \end{aligned}$$

$$\begin{aligned} \text{the generator capacity required} & = \frac{378 \times 2200}{1000} \\ & = 830 \text{ kv.a.} \end{aligned}$$

By the use of an overexcited synchronous motor, the power factor of the system is improved, the generator capacity required for the load is reduced, and so also is the current in the line, so that overexcited synchronous motors may be used with advantage at the end of a long line.

286. Synchronizing.—Before a synchronous motor can carry a load it must be started and brought up to synchronous speed, and the switch S , Fig. 298, should not be closed until E_m is equal and opposite to E_g . If this switch were closed when E_m and E_g are acting in the same direction round the closed circuit, then the resultant voltage E_r would be equal to $E_m + E_g$ and would send a destructive current I through the circuit. When E_m and E_g are equal and opposite, then E_r is zero, and no current I will flow when the switch S is closed. To test for this condition, a lamp L , or an indicating device called a synchroscope, is placed

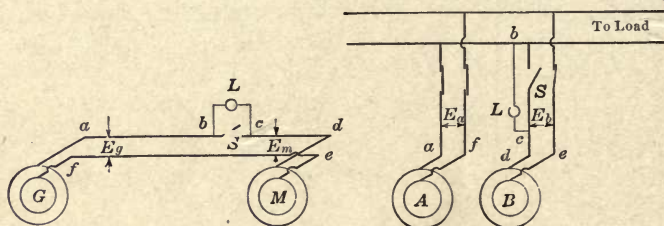

FIG. 298.—Alternator driving a synchronous motor.

FIG. 299.—Alternators in parallel.

across the switch S . When the lamp is brightest, then $E_r = E_m + E_g$; when darkest, then $E_r = \text{zero}$ and the switch S may be closed, after which the load may be put on the motor. The operation described above is called synchronizing.

287. Hunting.—In the case of an engine-driven alternator, and particularly if the engine is a gas engine, the angular velocity is not uniform but consists of a uniform angular velocity with a superimposed oscillation, the frequency of the generated e.m.f. therefore is not constant, but rises and falls regularly.

If this e.m.f. is applied to a synchronous motor, the synchronous speed of the motor tends to rise and fall regularly with the frequency, and the motor tends to have a superimposed oscillation similar to that of the alternator. If the natural period of oscillation of the motor has the same frequency as this forced oscillation then the effect will be cumulative and the motor will oscillate considerably.

A similar result would be found with the model shown in Fig. 291. If the torque applied to G is not uniform, then G will oscillate about its position of mean angular velocity and M will have an oscillating force impressed on it by the spring. If the moment of inertia of the flywheel M is such that its natural frequency of oscillation is the same as the frequency of the impressed oscillation then G and M will swing backward and forward relative to one another through a considerable angle.

As the two machines M and G oscillate relative to one another, the angle θ , Fig. 294, increases and decreases regularly, and the value of both E_r and of the current I vary above and below the average value required for the load. This surging of current is of comparatively low frequency and is indicated by an ammeter placed in the circuit. Due to this surging, the circuit breakers protecting the machines may be opened although the load is not greater than normal, while the cumulative swinging of the machines relative to one another, called hunting, may cause the motor to drop out of step.

To prevent hunting, the impressed oscillations must be eliminated or the natural frequency of vibration of the motor must be changed. The methods used in practice to minimize hunting are:

1. Dampen the governor if the impressed oscillations are found to be caused by a hunting governor.
2. Change the natural period of vibration of the machine by changing the flywheel; the larger the moment of inertia of the rotating part of the motor, the longer is its natural period of vibration.
3. Dampen the oscillations electrically by the use of pole dampers such as those described on page 295.

288. Parallel Operation of Alternators.—Two alternators connected to operate in parallel are shown in Fig. 299. If the voltage of machine B is not exactly equal and opposite to that of A at every instant then current will flow in the local circuit between the two machines just as in Fig. 298. To prevent this the two machines must be synchronized in the same way as an alternator and a synchronous motor; when the lamp L in Fig. 299 is dark, then E_b is exactly equal and opposite to E_a and the machines have the same frequency; the switch S may then be closed. If now the engine of B fails for an instant, then generator B will tend to slow down and will swing back relative to A , so that

current will flow in the local circuit and B will be driven as a synchronous motor in the same direction as before and at the same speed. As soon as the engine of B recovers, the generator will swing forward again and carry its share of the load.

If two direct-current generators are operating in parallel, and the field excitation of one of the machines is increased, then the voltage of that machine will be raised and it will take a larger portion of the load. An increase in load makes the engine and generator slow down and allows the engine to draw the additional amount of steam required for the additional load.

If two alternators are operating in parallel, an increase in the excitation of one machine raises the voltage of that machine and tends to make it carry more of the load. But the machine cannot slow down and allow the engine to take more steam because it can run only at synchronous speed. An increase in excitation of one machine therefore increases its voltage and at the same time makes the current in that machine lag further behind the voltage so as to maintain the load $EI \cos \alpha$ constant at the value corresponding to the steam supply. To change the distribution of load between two alternators operating in parallel, the governors of the driving engines must be manipulated so as to change the distribution of the steam supply.

As the total load on the two alternators increases, they both slow down, and the engine governors automatically allow the necessary amount of steam to flow, while the frequency of the generated e.m.f. decreases slightly. In order that the two machines may divide the load properly, the engines should have the same per cent. drop in speed between no-load and full-load.

The same applies to alternators driven by water wheels. To make any one of a number of turbine-driven alternators take a larger portion of the total load, the governor of that machine must be manipulated to allow the turbine to take more water.

CHAPTER XXXIV

TRANSFORMER CHARACTERISTICS

289. In order that electric energy may be transmitted economically over long distances, high voltages must be used; but in order that electric circuits may be safely handled, low voltages are necessary for distribution. The alternating-current transformer is a piece of apparatus by means of which electricity can be received at one voltage and delivered at another voltage either higher or lower. It consists essentially of two coils wound on an iron core; one coil receives energy and is called the primary coil, the other delivers energy and is called the secondary coil.

290. Constant Potential Transformer.—In Fig. 300, C is a closed magnetic circuit on which are wound two coils having n_1 and n_2 turns respectively. When an alternating e.m.f. e_1 is applied to the coil n_1 while coil n_2 is closed through a circuit as shown, then a current i_1 flows in the primary coil and produces an alternating magnetic flux ϕ which threads both coils and generates in them electromotive forces e_{1b} and e_2 which are proportional to n_1 and n_2 the number of turns.

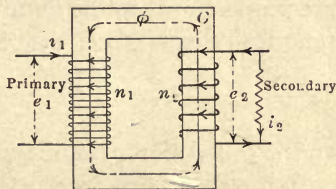

FIG. 300.—The transformer.

Now e_{1b} is called the back e.m.f. of the primary and, according to Lenz's law, opposes the change of the flux which produces it and therefore opposes e_1 which produces the change of flux; e_{1b} is less than e_1 by the e.m.f. required to send the current i_1 through the primary coil, which e.m.f. is small in modern transformers and seldom exceeds 1 per cent. of e_1 even at full-load.

The e.m.f. e_2 sends a current i_2 through the secondary winding in such a direction as to oppose the change of the flux ϕ which produces it, and therefore to oppose i_1 ; but the magnetizing effect of i_1 must always be greater than the demagnetizing effect of i_2 by the amount necessary to produce the flux ϕ in the magnetic circuit.

If now the impedance of the secondary circuit is decreased, the current i_2 will increase and thereby reduce the flux ϕ . But a reduction in ϕ causes the back e.m.f. e_{1b} to decrease and thereby allow a larger current i_1 to flow in the primary winding, so that the primary current always adjusts itself to suit the requirements of the secondary circuit.

Now the primary resistance is so small that e_{1b} and ϕ do not drop more than about 1 per cent. between no-load and full-load, so the statement may be made that ϕ is constant at all loads and therefore the resultant of $n_1 i_1$ and $n_2 i_2$, the primary and the secondary ampere-turns, must always be equal to some quantity $n_1 i_0$ which produces the constant flux ϕ .

The quantity $n_1 i_0$ may readily be found because, if the secondary circuit be opened, no current can flow in that winding, and the current in the primary under these conditions has merely to produce the flux ϕ . This current must therefore be i_0 and is called the magnetizing current of the transformer.

Since e_{1b} and e_2 are produced by the same magnetic flux ϕ they are proportional to the number of turns n_1 and n_2 , and since e_{1b} is practically equal to e_1 therefore

$$\frac{e_1}{e_2} = \frac{n_1}{n_2}$$

and is called the ratio of transformation.

It has also been shown that the resultant of $n_1 i_1$ and of $n_2 i_2$ must always be equal to $n_1 i_0$ where i_0 , called the magnetizing current, is comparatively small, so that if i_0 be neglected then

$$\begin{aligned} n_1 i_1 &= n_2 i_2 \\ \text{or} \quad \frac{n_1}{n_2} &= \frac{i_2}{i_1} = \frac{e_1}{e_2} \\ \text{and} \quad e_1 i_1 &= e_2 i_2 \end{aligned}$$

According to the law of conservation of energy, the input to a transformer must be exactly equal to the output, the losses being neglected (the efficiency of a 50-kilovolt ampere transformer is 98 per cent.) therefore

$$\begin{aligned} e_1 i_1 \cos \alpha_1 &= e_2 i_2 \cos \alpha_2 \\ \text{and} \quad e_1 i_1 &= e_2 i_2 \\ \text{therefore} \quad \cos \alpha_1 &= \cos \alpha_2 \end{aligned}$$

so that, neglecting the magnetizing current and the losses, the power factor of the primary is the same as that of the secondary.

291. Vector Diagram for a Transformer.—(a) No-load conditions. For a transformer which has a negligible no-load loss, the voltage and current phase relations are shown in Fig. 301.

ϕ is the magnetic flux threading both coils.

i_0 is the magnetizing current which produces ϕ .

e_2 and e_{1b} are the e.m.fs. generated in the coils n_2 and n_1 respectively, and lag the flux which produces them by 90 degrees, see the footnote on page 207.

e_1 , the applied primary e.m.f., is equal and opposite to e_{1b} .

(b) Full-load conditions. Let the secondary circuit now be closed and let its resistance and reactance be such that i_2 lags e_2 by α_2 degrees, then the voltage and current phase relations are as shown in Fig. 302.

ϕ is the magnetic flux threading both coils and has practically the same value at full-load as at no-load.

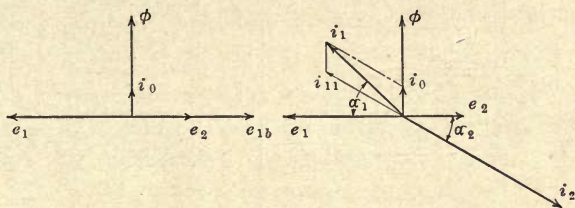

FIG. 301.—No load.

FIG. 302.—Full load.

Vector diagrams for a transformer.

i_0 is the component of the primary current required to produce the flux ϕ .

e_1 is the applied primary e.m.f.

e_2 is the secondary generated e.m.f.

i_2 is the secondary current, whose value and whose phase angle α_2 depend on the constants of the connected circuit.

i_{11} is the component of the primary current required to neutralize the demagnetizing effect of the current i_2 ;

$$n_1 i_{11} = n_2 i_2$$

i_1 is the primary current and is the resultant of i_0 and i_{11} .

If the current i_0 is small, then $\alpha_1 = \alpha_2$ and $n_1 i_1 = n_2 i_2$.

292. Induction Furnace.—An electric furnace which operates as a transformer is shown diagrammatically in Fig. 303 and is called an induction furnace, the secondary winding in this case being the charge which is contained in the annular channel A

and is heated by the secondary current. The amount of energy put into the secondary can be varied by varying the applied primary voltage.

Fig. 304 shows diagrammatically an electric welder which operates on the same principle. The single turn A in this case is open, and is closed by the two pieces to be welded, which pieces are held in the clamps B and are forced together under pressure while the welding current passes across the contact and heats the ends to be joined.

It might seem that, since the secondary load in this case is a resistance load being the resistance of the molten metal, the power factor of the transformer would be high at full-load, and yet in practice it seldom exceeds 70 per cent. To explain the

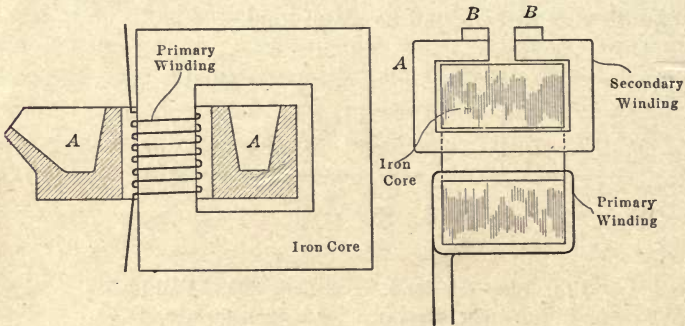

FIG. 303.—Induction furnace.

FIG. 304.—Induction welder.

cause of this low power factor it is necessary to take up the subject of leakage flux in transformers.

293. Leakage Reactance.—Fig. 306 shows the actual flux distribution in a transformer. The ampere-turns $n_1 i_1$ produce a flux ϕ_{1l} , called the primary leakage flux, which is proportional to i_1 and which threads the coil n_1 but does not thread n_2 .

The ampere-turns $n_2 i_2$ produce a flux ϕ_{2l} , called the secondary leakage flux, which is proportional to i_2 and which threads the coil n_2 but does not thread n_1 .

The ampere-turns $n_1 i_1$ and $n_2 i_2$ acting together produce a magnetic flux ϕ which threads both coils n_1 and n_2 and which is practically constant in magnitude; the effect of this constant flux has already been considered.

Now any coil in which a current i produces a flux ϕ which is proportional to the current is said to have self induction, see

Art. 239, page 206, and the voltage to send an alternating current I through such a coil = IX where X is the reactance of the coil; the current lags this voltage by 90 degrees, see page 208.

In Fig. 306, the flux ϕ_{1l} is proportional to the current i_1 and its effect is the same as if the coil n_1 had a reactance X_1 so that, instead of considering the effect of the flux ϕ_{1l} , the effect of the

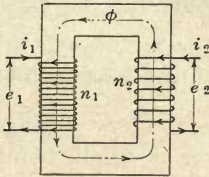

FIG. 305.

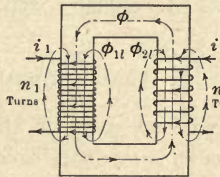

FIG. 306.

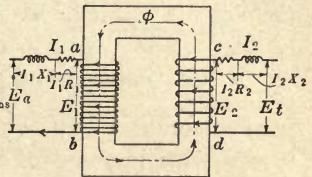

FIG. 307.

FIG. 305.—Ideal transformer.

FIG. 306.—Actual flux distribution in a transformer.

FIG. 307.—Transformer showing the resistances and reactances diagrammatically.

equivalent reactance X_1 may be considered. In the same way the leakage flux ϕ_{2l} may be represented by an equivalent reactance X_2 . Fig. 307 shows the diagram of an actual transformer in which the leakage fluxes ϕ_{1l} and ϕ_{2l} are replaced by the equivalent reactances X_1 and X_2 which, along with the resistances R_1 and R_2 of the coils, are placed for convenience outside of the actual winding.

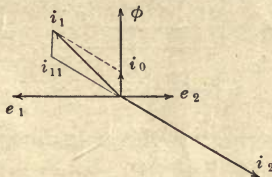

FIG. 308.—Vector diagram of an ideal transformer.

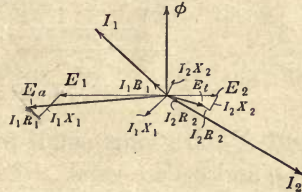

FIG. 309.—Vector diagram of an actual transformer.

Between the terminals ab and cd , the transformer diagram in Fig. 307 is the same as the ideal diagram in Fig. 305. The vector diagram for this ideal transformer is shown in Fig. 308 which is the same as Fig. 302, page 263.

The actual terminal voltage E_t is obtained by subtracting from E_2 the vectors $I_2 R_2$ and $I_2 X_2$, the voltages to overcome the sec-

ondary resistance and reactance respectively, where I_2R_2 is in phase with I_2 and I_2 lags I_2X_2 by 90 degrees.

The applied primary voltage E_a is obtained by adding to E_1 the vectors I_1R_1 and I_1X_1 , the primary resistance and reactance drops.

In the elementary discussion of transformer operation, the resistance and reactance drops were neglected and it was found

that $\frac{E_2}{E_1} = \frac{n_2}{n_1}$. In Fig. 309 this relation still holds, but the ratio

$\frac{E_l}{E_a}$ is less than $\frac{E_2}{E_1}$ and so less than $\frac{n_2}{n_1}$, so that the transformer

ratio decreases as the load increases or the secondary voltage drops with increase of load; this drop however is small, being less than 2 per cent. for a 5 kv.a. transformer at 100 per cent. power factor, while for leading currents in the secondary circuit the secondary voltage may rise with increase of load just as in the case of the alternator, see page 245; the student may satisfy himself on this point by drawing the vector diagram.

294. Leakage Reactance in Standard Transformers and in Induction Furnaces.—In power transformers, the leakage reactances

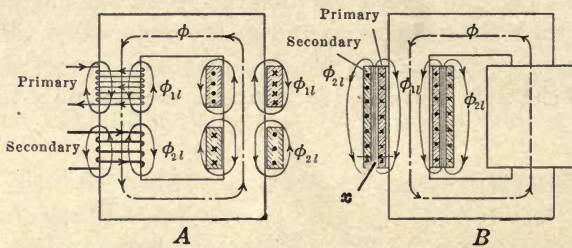

FIG. 310.—Leakage flux of transformers.

X_1 and X_2 are kept small by constructing the transformer so that ϕ_{1l} and ϕ_{2l} are small. Diagram A, Fig. 310, shows a transformer with a primary and a secondary coil on each leg and shows also the leakage fluxes. It may be seen from this diagram that, on each leg, ϕ_{1l} and ϕ_{2l} act in opposite directions, so that if n_2 were interwound with n_1 then the leakage fluxes would neutralize and only the main flux ϕ be left. This result is approximated in practice by constructing the transformer as shown in diagram B, where half of the primary and half of the secondary winding are placed over one another on each leg of the transformer core, the leakage fluxes have then to crowd into the space x between the

windings, and the smaller the space x , the smaller the leakage fluxes and the smaller the leakage reactances.

In the induction furnace, unfortunately, the distance x cannot be made small, so that the reactances are comparatively large. The vector diagram for such a furnace is shown in Fig. 311. The secondary winding is short-circuited since it consists of a ring of molten metal, so that E_t , the terminal voltage, is zero, and the secondary generated voltage E_2 is therefore made up of the two components I_2R_2 and I_2X_2 , where R_2 is the resistance of the ring of molten metal and X_2 its reactance due to the leakage flux ϕ_{2l} , Fig. 307. The remainder of this diagram is determined in the same way as in Fig. 309, and the power factor of the furnace is the $\cos \alpha_1$ and seldom exceeds 70 per cent.

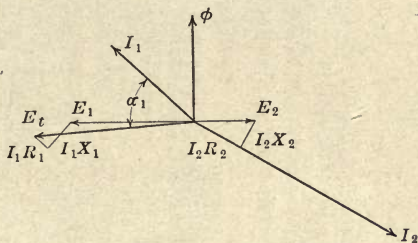

FIG. 311.—Vector diagram for an induction furnace.

295. The Constant-current Transformer.—For the operation of arc lamps in series, the constant-current transformer shown in Fig. 312 is used. The primary coil is stationary and receives power at constant potential, while the secondary coil, which is suspended and is free to move toward or away from the primary, delivers a constant current to the lighting circuit.

When the secondary coil is close to the primary, the reactances of the transformer are small and the secondary voltage is approximately equal to the primary voltage multiplied by the ratio of the number of turns. As the distance between the coils is increased, the leakage flux and the reactances increase and the secondary voltage drops, even although the primary voltage remains constant.

The primary and the secondary currents are opposite in direction and, under these conditions, the primary and the secondary coils repel one another. The counterweight on the secondary coil is so adjusted that, when the desired current is

flowing in this coil, the force of repulsion keeps the secondary coil suspended. If then some of the lamps in the circuit are cut out, the current tends to increase, but any increase in the current separates the coils and the voltage drops due to the increased reactance and so is unable to maintain the current at the increased value. The power factor of such a transformer

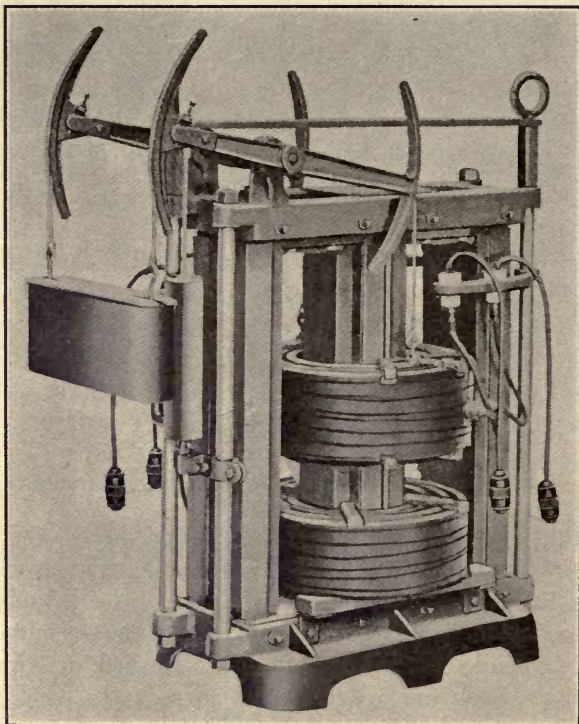

FIG. 312.—Constant-current transformer.

is high when the coils are close together but decreases as the distance between the coils is increased.

296. The efficiency of a transformer

$$= \frac{\text{output}}{\text{input}} = \frac{\text{output}}{\text{output} + \text{losses}}$$

where the losses are:

Iron losses; the hysteresis and eddy current losses in the core.

Copper losses; these are $I_1^2 R_1$ and $I_2^2 R_2$ watts respectively for

the primary and secondary windings. There is no power loss due to the primary and secondary reactances, see page 209.

297. Hysteresis Loss.—Since the flux in a transformer core is alternating, power is required to continually reverse the molecular magnets of the iron, this power is called the hysteresis loss.

298. Eddy Current Loss.—If the transformer core in Fig. 313 is made of a solid block of iron, then the alternating flux ϕ threading this core causes currents to flow as shown at *A*, in the same way as through a short-circuited secondary winding. Power is required to maintain these eddy currents which power is called the eddy current loss.

To keep these eddy currents small, a high resistance is placed in their path. This is accomplished by laminating the core, as shown at *B*, the laminations being separated from one another by varnish.

299. Iron Losses.—The hysteresis and the eddy current losses taken together constitute what is called the iron loss. Since the flux per pole is practically constant at all loads, see page 262, therefore the iron loss caused by this flux is also constant at all loads. This loss may readily be determined by operating the transformer at no-load with normal voltage and frequency, the input under these conditions, measured by a wattmeter, is equal to the iron loss, the small copper loss due to the no-load current being neglected.

300. The all-day efficiency is defined as the ratio of the total energy used by the customer to the total energy input to the transformer, during twenty-four hours. This efficiency is of importance in the case of lighting transformers, which are connected to the mains for twenty-four hours a day but which supply energy for about five hours a day, under such conditions the all-day efficiency =

$$\frac{\text{output} \times h}{\text{output} \times h + \text{iron loss} \times 24 + \text{copper loss} \times h}$$

where h is the number of hours per day during which energy is taken from the transformer.

In a 50-kv.a. 2200- to 220-volt transformer the iron loss is 300 watts, the primary resistance is 0.5 ohms and the secondary resistance is 0.005 ohms. Find

a. The efficiency when the load is 50 kw. and the power factor 100 per cent.

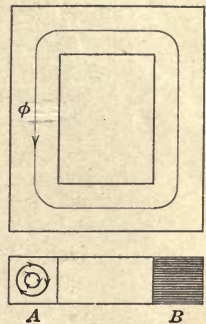

FIG. 313.—Transformer core.

b. The efficiency when the load is 5 kw. and the power factor 100 per cent.

c. The efficiency when the load is 50 kv.a. and the power factor 80 per cent.

d. The all-day efficiency in the latter case if the load is constant and connected for 5 hours a day while the transformer is connected to the line for 24 hours a day.

a. I_2 , the secondary current = $50000/220 = 227$ amp.

I_1 , the primary current = $50000/2200 = 22.7$ amp. approximately

Copper loss	$= 227^2 \times 0.005 + 22.7^2 \times 0.5$	= 514 watts.
Iron loss		= 300 watts
Total loss		= 814 watts
Output		= 50,000 watts
Input		= 50,814 watts
Efficiency		= 98.5 per cent.

b. $I_2 = 5000/220 = 22.7$ amp. and $I_1 = 5000/2200 = 2.27$ amp. approx.

Copper loss	$= 22.7^2 \times 0.005 + 2.27^2 \times 0.5$	= 5.14 watts
Iron loss		= 300 watts
Total loss		= 305 watts
Output		= 5000 watts
Input		= 5305 watts
Efficiency		= 94.4 per cent.

c. $I_2 = 50000/220 = 227$ amp. and $I_1 = 50000/2200 = 22.7$ amp. approx.

Copper loss	$= 227^2 \times 0.005 + 22.7^2 \times 0.5$	= 514 watts
Iron loss		= 300 watts
Total loss		= 814 watts
Output		= 40,000 watts
Input		= 40,814 watts
Efficiency		= 98 per cent.

$$d. \text{ All-day efficiency} = \frac{40000 \times 5}{40000 \times 5 + 300 \times 24 + 514 \times 5} = 95.5 \text{ per cent.}$$

301. Cooling of Transformers.—Transformers become heated up due to the losses. This heat must be dissipated and the temperature of the transformer windings kept below the value at which the insulation begins to deteriorate. Transformers with an output of less than 1 kv.a. can dissipate their heat by direct radiation, but it is usual to place all transformers up to 500 kv.a. into a steel tank, which is then filled with insulating oil above the level of the windings. The oil improves the insulation, and convection currents are set up in the oil by means of which the heat is carried from the surface of the transformer to the larger surface of the tank, from which it is dissipated to the surrounding air. Such a transformer is said to be self cooled.

The losses in a transformer are proportional to the volume of

the transformer, while the radiating surface is equal to the superficial area, so that, as the size of the transformer increases, the losses increase more rapidly than the radiating surface; special arrangements must therefore be made for cooling transformers of large output.

For outputs from 50 to 500 kv.a., corrugated tanks such as that in Fig. 314 are used, while for outputs from 500 to 2000 kv.a.,

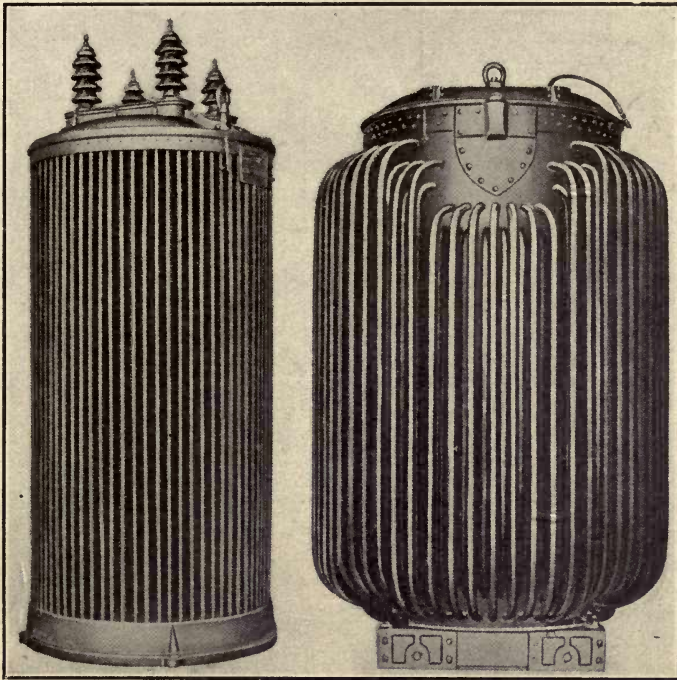

FIG. 314.—Corrugated tank.

FIG. 315.—Tank with external cooling pipes.

more surface must be provided than can be obtained from a corrugated tank and the construction shown in Fig. 315 is used; for outputs greater than 2000 kv.a., other methods of cooling allow the use of a smaller and cheaper transformer.

The water-cooled type is shown in Fig. 316; cold water is circulated through the water coil and takes the heat from the hot upper layers of the oil. About $2\frac{1}{2}$ lb. or a quarter of a gallon of water is required per minute per kilowatt loss in the transformer.

The air-blast type of transformer is shown in Fig. 317. The

transformer is well supplied with ducts so that the air can reach the points at which the heat is generated. This type of transformer is lighter than the oil-filled type but cannot be satisfactorily insulated for voltages greater than 30,000 volts. One hundred and fifty cubic feet of air is required per minute per kilowatt loss.

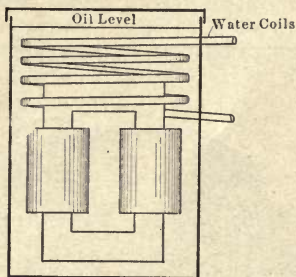

FIG. 316.—Diagrammatic representation of a water-cooled transformer.

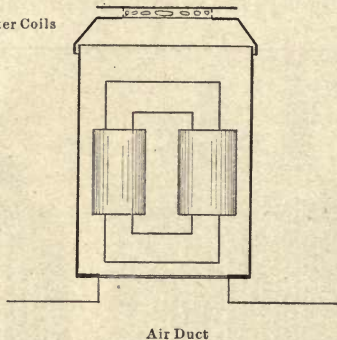

FIG. 317.—Diagrammatic representation of an air-blast transformer.

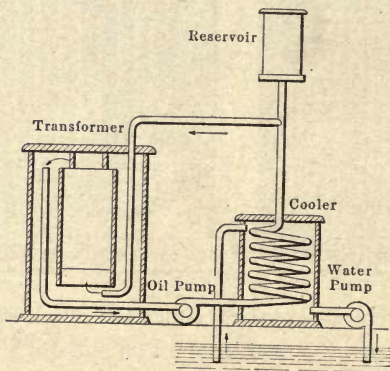

FIG. 318.—Method of cooling a transformer by circulating the oil.

The circulating oil type of transformer is shown in Fig. 318 and may be used with advantage where only hard water is available for cooling purposes. When such water is used in water-cooled transformers, salts are liable to deposit inside the cooling coils and throttle the supply of water. With the circulating oil method of cooling, these salts will deposit on the outside of the cooling coils.

CHAPTER XXXV

TRANSFORMER CONNECTIONS

302. Lighting Transformers.—These are generally built to transform from 2200 to 110 volts, but both primary and secondary windings are divided as shown diagrammatically in Fig. 319, and these windings may be so connected that a standard transformer can operate on the high-tension side at either 2200 or 1100 volts and on the low-tension side at either 220 or 110 volts. The different connections used are shown in Fig. 319.

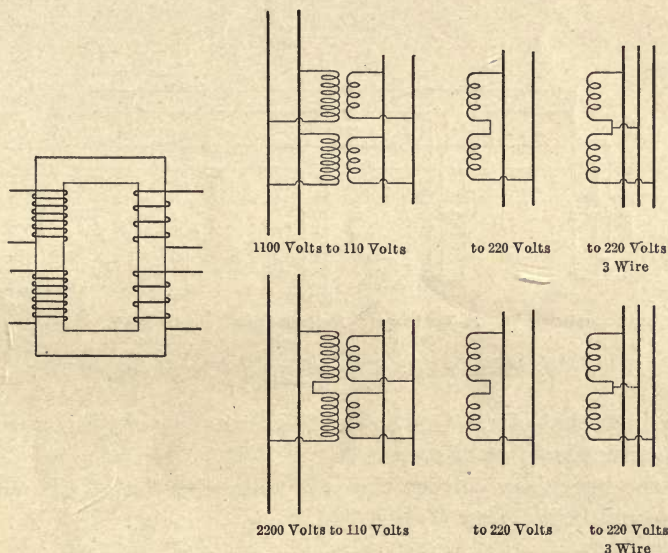

Fig. 319.—Standard connections for a lighting transformer.

303. Connections to a Two-phase Line.—In Fig. 320, diagram A shows the method of transforming from high-voltage two-phase to low-voltage two-phase, for the operation of motors.

Specify the transformers for a two-phase motor which delivers 50 h.p. at 440 volts with an efficiency of 90 per cent. and a power factor of 88 per cent., the line voltage being 2200.

$$\begin{aligned} \text{motor output} &= 50 \text{ h.p.} \\ &= 50 \times 0.746 = 37.2 \text{ kw.} \\ \text{motor input} &= 37.2/0.9 = 41.4 \text{ kw.} \\ &= 41.4/0.88 = 47 \text{ kv.a.} \end{aligned}$$

therefore two transformers are required each of 23.5 kv.a. output. The secondary current = $23500/440 = 53$ amp., the primary current, neglecting transformer losses = $23500/2200 = 10.7$ amp.

Diagram *B* shows the method of connecting a low-voltage single-phase load to a two-phase line; the load should be divided as equally as possible between the two phases.

Diagram *C* shows the Scott connection used to transform from two-phase to three phase. The two transformers *x* and *y* are wound for the same primary voltage, namely that of the two-phase line, but the secondary voltage of *y* is only $\sqrt{3}/2$ or

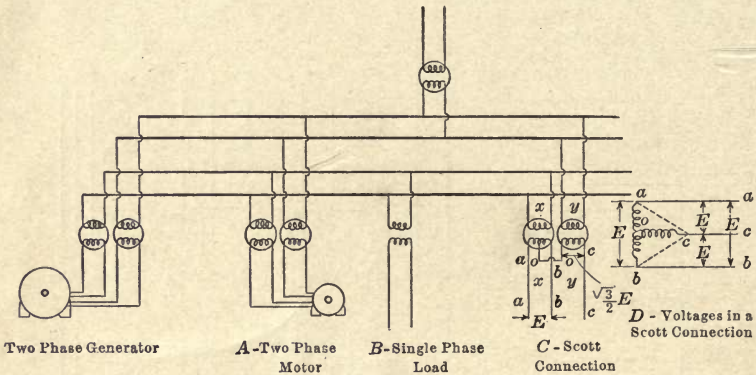

FIG. 320.—Connection of transformers to a two-phase line.

0.86 times that of *x*. One end of the secondary of *y* is connected to the middle point of *x*.

If the secondary voltage of *x* is *E* volts then that of *y* is $\sqrt{3}E/2$ volts and, in diagram *D*, Fig. 320,

the difference of potential between *a* and *b* = *E* volts

the difference of potential between *a* and *c* = $\sqrt{(ao)^2 + (oc)^2}$
= *E* volts

the difference of potential between *b* and *c* = *E* volts

and the phase relations between these voltages is the same as in a delta-connected bank of transformers.

A load which is balanced on the three-phase side is also balanced on the two-phase side. Fig. 321 shows the currents and voltages in a Scott connected

group which is used to transform from two-phase at E volts to three-phase at E volts.

Since the three-phase load is balanced, therefore I_1, I_2 and I_3 are all equal, and the kv.a. output on the three-phase side = $1.73EI$.

Now the magnetizing effect of the primary of a transformer is always equal to the magnetizing effect of the secondary, so that in transformer y

$$n_{1y} \times I_y = n_{2y} \times I$$

and

$$\frac{n_{1y}}{n_{2y}} = \frac{E}{\sqrt{3}E/2}$$

therefore

$$I_y = I \times \sqrt{3}/2$$

In transformer x , the current in $oa = I$ and that in ob also = I , but these currents are out of phase by 120 degrees and are in opposite directions there-

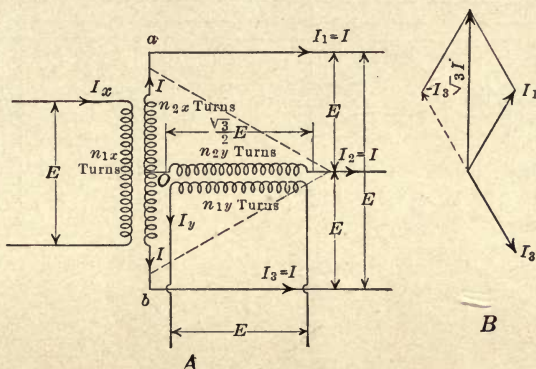

FIG. 321.—Voltage and current relations in a Scott-connected bank of transformers.

fore the resultant magnetizing effect is not equal to $n_{2x}I$ but to $n_{2x}I \times \sqrt{3}/2$ see diagram B

$$\text{now} \quad \frac{n_{1x}}{n_{2x}} = \frac{E}{E} = 1$$

$$\text{and} \quad n_{1x}I_x = n_{2x}I \times \sqrt{3}/2$$

$$\text{therefore} \quad I_x = I \times \sqrt{3}/2 = I_y$$

and the total two-phase kv.a. = $2EI_x = \sqrt{3}EI$, the same as on the three-phase side.

If a 50-h.p., 440-volt, three-phase motor is supplied from a 2200 volt, two-phase line, find the current I , Fig. 321, and also the currents I_x and I_y , if the efficiency of the motor is 90 per cent. and the power factor is 88 per cent.

$$\begin{aligned}
 \text{motor output} &= 50 \text{ h.p.} \\
 &= 50 \times 0.746 = 37.2 \text{ kw.} \\
 \text{motor input} &= 37.2/0.9 = 41.4 \text{ kw.} \\
 &= 41.4/0.88 = 47 \text{ kv.a.} \\
 &= \frac{1.73 \times E \times I}{1000} \text{ kv.a., Fig. 321} \\
 &= \frac{1.73 \times 440 \times I}{1000} \text{ kv.a.}
 \end{aligned}$$

and $I = 47,000/1.73 \times 440 = 62 \text{ amp.}$

neglecting transformer losses, $2 \times 2200 \times I_x = 47 \text{ kv.a.}$,
 and $I_x = 47,000/2 \times 2200 = 10.7 \text{ amp.}$

304. Connections to a Three-phase Line.—In Fig. 332: Diagram A shows three transformers connected Y on both primary and secondary sides. If E_1 is the voltage between the

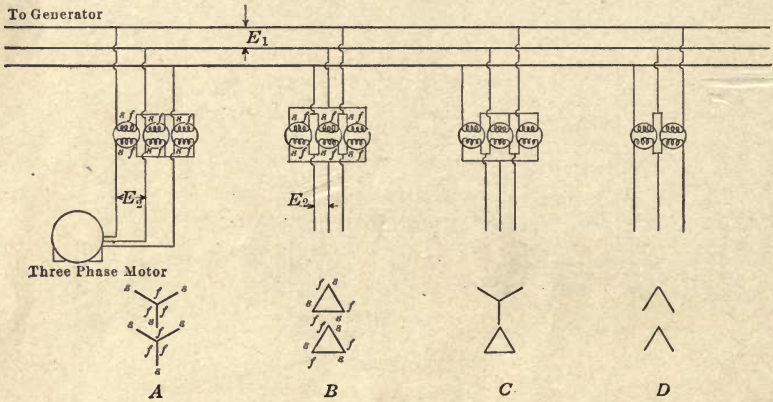

FIG. 322.—Connection of transformers to a three-phase line.

primary lines and E_2 is that between the secondary lines then
 The primary voltage of each transformer = $E_1/\sqrt{3}$, see page 236.
 The secondary voltage of each transformer = $E_2/\sqrt{3}$.
 The transformation ratio of each transformer = E_1/E_2 .

Diagram B shows the transformers connected delta on both primary and secondary sides:

The primary voltage of each transformer = E_1 , see page 237.
 The secondary voltage of each transformer = E_2 .
 The transformation ratio of each transformer = E_1/E_2 .

Diagram C shows the transformers connected Y on the primary side and delta on the secondary side:

The primary voltage of each transformer = $E_1/\sqrt{3}$.
 The secondary voltage of each transformer = E_2 .

The transformation ratio of each transformer = $E_1/\sqrt{3}E_2$.

In a delta connection, the voltage of any one phase at any instant is equal and opposite to the sum of the voltages in the other two phases, see page 233, so that if, in Fig. 323, one transformer *A* of a bank of delta-connected transformers is disconnected, the difference of potential between *a* and *b* is unchanged, being maintained by the transformers *B* and *C* in series, so that three-phase power can still be obtained from the lines *a*, *b* and *c*. This connection is called the *V* or open delta connection and is shown in diagram *D*, Fig. 322.

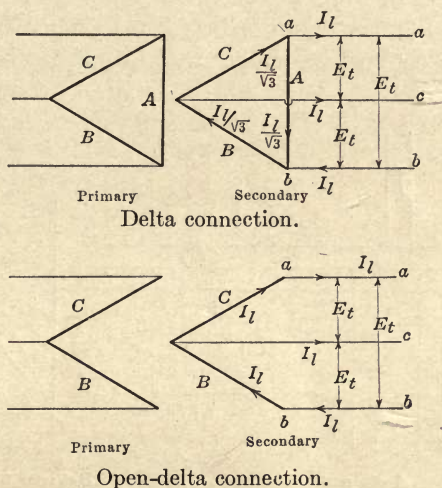

FIG. 323.—Comparison between the closed-delta and the open-delta connections.

In the open delta connection in Fig. 323.

The current in each transformer = I_l .

The voltage of each transformer = E_t

The rating of each transformer = $\frac{E_t I_l}{1000}$ kv.a.

But the total load on the three-phase line = $\frac{1.73 E_t I_l}{1000}$ kv.a.,

page 237, so that the rating of each transformer is greater than half the total load by the ratio 2/1.73 or by 15 per cent.

If 30 kv.a. has to be transmitted, then three delta-connected transformers may be used each with a capacity of 10 kv.a.

If one of these transformers is burnt out, then the power that can be transmitted by the remaining two transformers is not 20 kv.a., but

$$= 20 \times \sqrt{3}/2 = 17.3 \text{ kv.a.}$$

305. Advantages and Disadvantages of the Y and Delta Connection.—For a given voltage of 110,000 volts between lines, each transformer in a Y-connected bank has to withstand $110,000/\sqrt{3}$ or 64,000 volts and is therefore less liable to break down than the transformers in a delta-connected bank which have to withstand the full 110,000 volts.

When one transformer in a Y-connected bank breaks down, the system can no longer operate three-phase, whereas, if the transformers were connected delta, the faulty transformer could be

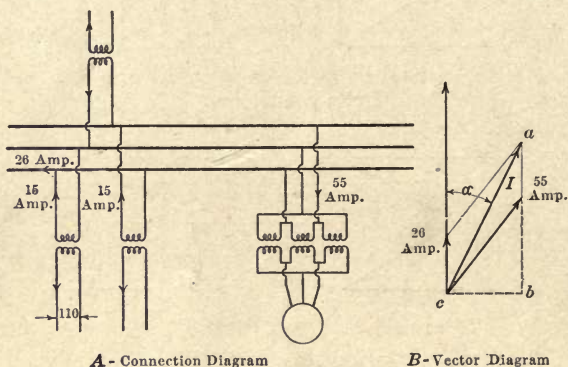

FIG. 324.

disconnected and about 58 per cent. of the load could still be carried by the two remaining transformers connected open delta.

Delta-connected transformers are used for practically all low voltage distribution. The Y to delta connection is often used for high-voltage work, the transformers being Y connected on the high-voltage side.

The load on a 2200-volt three-phase line consists of 1800, $1/2$ amp., 110 volt lamps on three circuits, and 200 h.p. of three-phase motors with an average power factor of 80 per cent. and an average efficiency of 88 per cent. all on one circuit. Draw the diagram of connections, specify the transformers, and find the current in the mains and also the resultant power factor. The connection diagram is shown in Fig. 324.

The kv.a. output of each motor transformer

$$\begin{aligned} &= 1/3(\text{motor kv.a.}) \\ &= 1/3(200 \times 0.746 \times \frac{1}{0.88} \times \frac{1}{0.8}) \\ &= 70 \text{ kv.a.} \end{aligned}$$

$$\text{the line current for the motors} = \frac{3 \times 70 \times 1000}{1.73 \times 2200} = 55 \text{ amp.}$$

the kv.a. output of each lighting transformer

$$\begin{aligned} &= \frac{600 \times 0.5 \times 110}{1000} \\ &= 33 \text{ kv.a.} \end{aligned}$$

$$\text{the primary current in each transformer} = \frac{33,000}{2200} = 15 \text{ amp., but these}$$

transformers form a delta-connected load on the line, see Fig. 269, page 237, therefore the current in each line = $1.73 \times 15 = 26$ amp.

the resultant current in the line is the resultant of 26 amp. at 100 per cent. power factor and of 55 amp. at 80 per cent. power factor and is equal to

$$\begin{aligned} I &= \sqrt{ab^2 + bc^2}, \text{ diagram } B \\ &= \sqrt{(0.8 \times 55 + 26)^2 + (0.6 \times 55)^2} \\ &= 77.5 \text{ amp} \end{aligned}$$

$$\begin{aligned} \text{the power factor} &= \frac{ab}{ac} = \frac{0.8 \times 55 + 26}{77.5} \\ &= 90.5 \text{ per cent.} \end{aligned}$$

306. Types of Transformer.—The transformer shown in Fig. 325 is said to be of the core type. If the coil on limb *B* is placed on *A*, and the iron of *B* is split and bent over as shown in Fig. 326, the resulting transformer is said to be of the shell type.

For three-phase transmission there is a considerable saving in cost and floor space if, instead of a bank of three transformers each in its own tank, a three-phase transformer is used in which the windings of the three phases are all placed on the same core as shown in Figs. 327 and 328. The principal objection to the three-phase transformer is that a breakdown in the winding of one phase puts the whole transformer out of commission, so that such transformers are used only in large central stations where there is ample reserve capacity.

307. The Autotransformer.—If a reactance coil is placed across an alternating-current line as shown in Fig. 329, the voltage E_2 obtained by tapping the coil as shown may have any value less than E_1 , and, as in the transformer, $\frac{E_1}{E_2} = \frac{n_1}{n_2} = \frac{I_2}{I_1}$. Since the

primary and secondary currents oppose one another, the current in the section *ab* is the difference between the currents I_1 and I_2 .

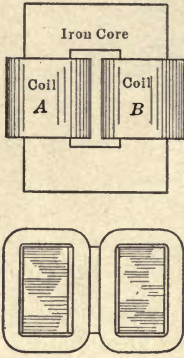

FIG. 325.—Core type of transformer.

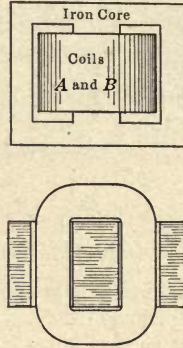

FIG. 326.—Shell type of transformer.

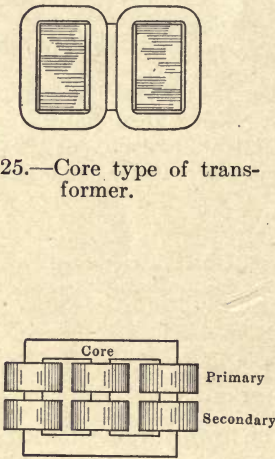

FIG. 327.—Three-phase core type of transformer.

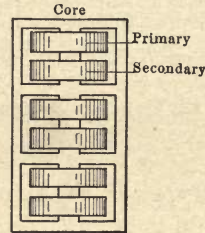

FIG. 328.—Three-phase shell type of transformer.

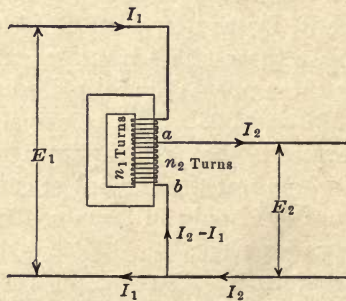

FIG. 329.—Autotransformer.

When the transformation ratio is comparatively small, the autotransformer, as this reactance coil is called, is cheaper than

the equivalent transformer with separate windings. It is much used for reducing the voltage applied to alternating-current motors during the starting period, see page 301.

308. Boosting Transformers and Feeder Regulators.—The voltage of a line may be raised by a small amount if a standard transformer is connected as shown in Fig. 330. The voltage of the line is boosted by the amount of the secondary voltage E_2 .

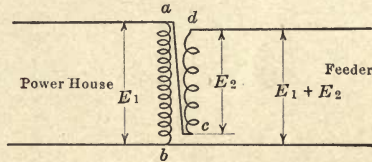

FIG. 330.—Boosting transformer.

When the secondary side of the transformer is tapped so that the boosting effect can be adjusted, the resulting piece of apparatus is the Stillwell feeder regulator. It is used to raise the feeder voltage above that of the power house, so as to compensate for the voltage drop in the feeder and maintain the voltage at the load.

Another type of feeder regulator is shown in Fig. 331. The

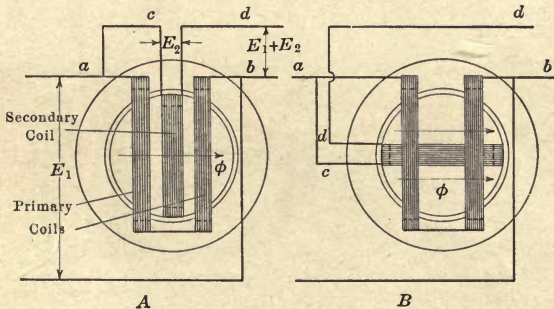

FIG. 331.—Induction regulator.

secondary coil in this case is movable relative to the primary. When the coils are in the relative position shown in diagram A, the voltage E_2 has its maximum value; when the secondary coil is moved through 90 degrees relative to the primary, as shown in diagram B, then the flux ϕ which threads the secondary coil is zero, and no voltage is induced in that coil. Such regulators may be made automatic if the core is turned by means of a small motor

which is controlled by a solenoid connected across the line to be regulated. When the line voltage increases, the plunger of the solenoid is raised and closes the motor circuit, and the motor then turns the regulator in such a direction as to lower the voltage. When the line voltage decreases, the plunger of the solenoid drops and reverses the motor, so that it now turns the regulator in the opposite direction.

CHAPTER XXXVI

POLYPHASE INDUCTION MOTORS

309. The induction motor is used for practically all the power work when only alternating current is available. The essential

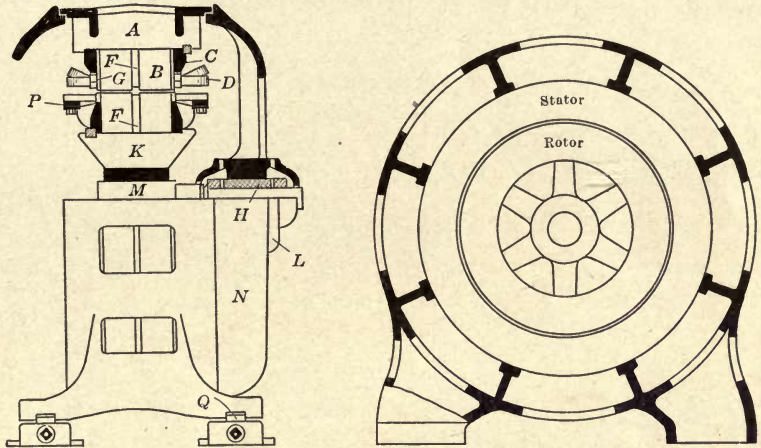

FIG. 332.—Squirrel-cage induction motor.

parts of such a machine are shown in Fig. 332. The stator or stationary part is exactly the same as that of an alternator, the

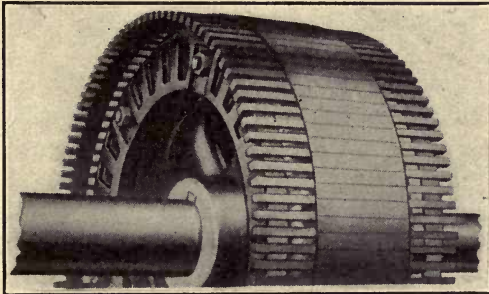

FIG. 333.—Squirrel-cage rotor.

rotor, however, is entirely different and the type most generally used, called the squirrel-cage type, consists of a cylindrical core

which carries a large number of copper bars on its periphery which bars are all joined together at the ends by copper or brass-end connectors as shown in Fig. 333. The action of this machine will be explained in detail.

310. The Revolving Field.—Diagram *P*, Fig. 334, shows the essential parts of a two-pole, two-phase induction motor. The stator carries two windings *M* and *N* which are spaced 90 electrical degrees apart and, in the actual machine, are bent back so that the rotor may readily be inserted. These windings are

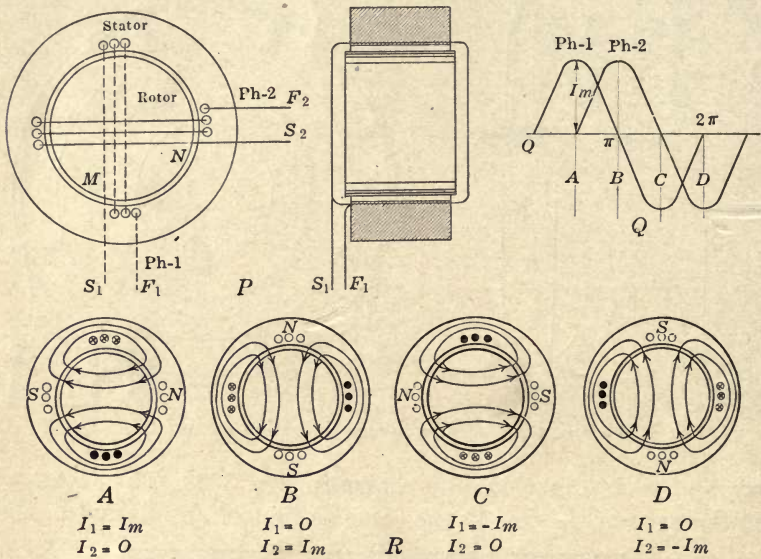

FIG. 334.—Revolving field of a two-pole, two-phase induction motor.

connected by wires to two-phase mains and the currents which flow at any instant in the coils *M* and *N* are given by the curves in diagram *Q*; at instant *A* for example the current in phase 1 = $+ I_m$ while that in phase 2 is zero.

The windings of each phase are marked *S* and *F* at the terminals and these letters stand for start and finish respectively; a + current is one that goes in at *S* and a - current one that goes in at *F*.

The resultant magnetic field produced by the windings *M* and *N* at instants *A*, *B*, *C* and *D* is shown in diagram *R* from which it may be seen that, although the windings are stationary, a revolving field is produced which is of constant strength and which

goes through one revolution while the current in one phase passes through one cycle.

311. The Revolving Field of a Three-phase Motor.—Diagram *P*, Fig. 335, shows the winding for a two-pole three-phase motor; *M*, *N* and *Q*, the windings of the three phases, are spaced 120 electrical degrees apart. These windings are connected to the three-phase mains and may be connected either Y or delta, see page 237, in either case the currents which flow at any instant in

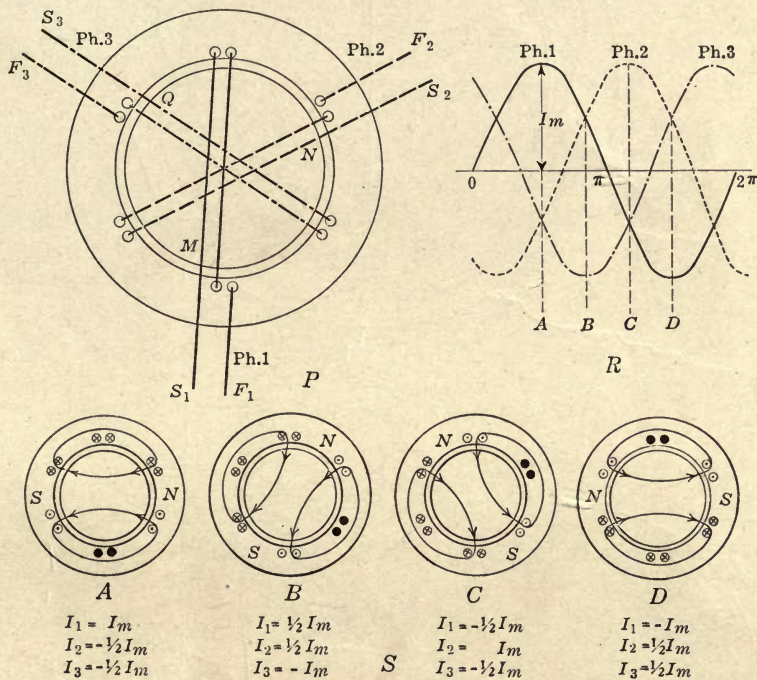

FIG. 335.—Revolving field of a two-pole, three-phase induction motor.

the coils *M*, *N* and *Q* are given by the curves in diagram *R*; at instant *A* for example the current in phase 1 = $+I_m$ that in phase 2 = $-\frac{I_m}{2}$ and that in phase 3 is also = $-\frac{I_m}{2}$.

The resultant magnetic field produced by the windings at instants *A*, *B*, *C* and *D* is shown in diagram *S* from which it may be seen that, just as in the case of the two-phase machine, a revolving field is produced which is of constant strength and which goes through one revolution while the current in one phase passes through one cycle.

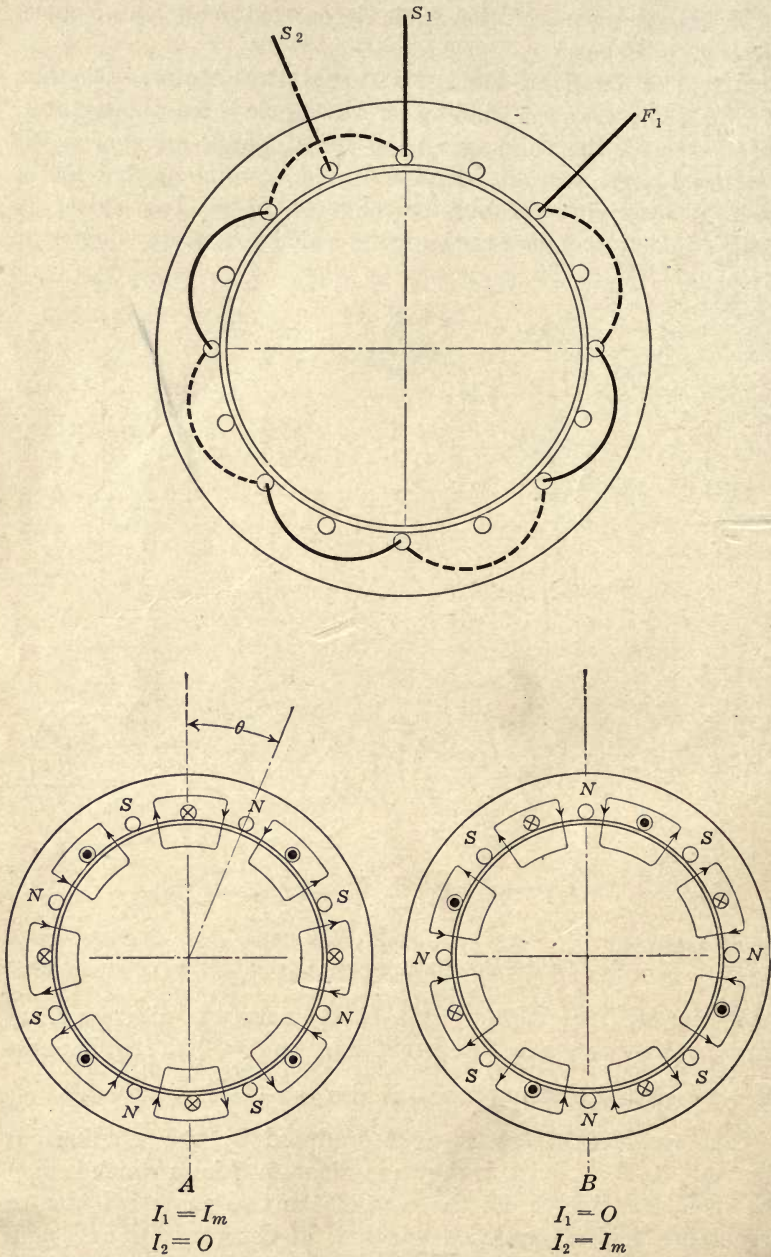

FIG. 336.—Revolving field of an eight-pole, two-phase induction motor.

312. Multipolar Machines.—Fig. 336 shows part of the winding of an eight-pole, two-phase induction motor and also the resultant magnetic field at the instants *A* and *B*, Fig. 334. The field moves through the angle θ , or through half the distance between two adjacent poles or $\frac{1}{2p}$ of a revolution, in the time interval between the instants *A* and *B* or in $\frac{1}{4f}$ seconds, therefore the speed of the revolving field

$$\begin{aligned} &= \frac{1}{2p} \times 4f \text{ rev. per sec.} \\ &= \frac{120f}{p} \text{ rev per. min.} \end{aligned}$$

This is called the synchronous speed, and is the speed at which an alternator with the same number of poles must be run in order to give the same frequency as that applied to the motor, the table on page 195 therefore applies to induction motors as well as to alternators.

313. The Starting Torque.—Let the revolving field of a two-pole machine, produced by either a two- or a three-phase stator,

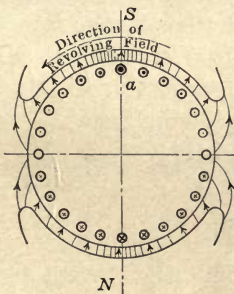

FIG. 337.—Direction of the e.m.f. in the rotor bars.

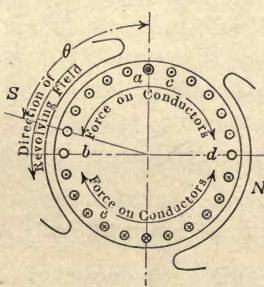

FIG. 338.—Direction of the currents in the bars of a low resistance rotor.

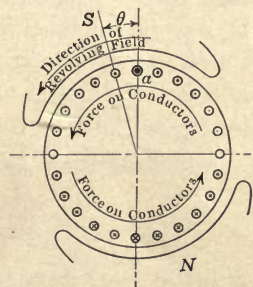

FIG. 339.—Direction of the currents in the bars of a high resistance rotor.

be represented by a revolving north and south pole as shown in Fig. 337. The field is moving in the direction of the arrow and therefore cuts the stationary rotor bars and generates in them e.m.fs. which are shown by crosses and dots. The e.m.f. will be a maximum in the conductor which is in the strongest field and the direction of the e.m.f. in each conductor may be found by the right hand rule, see page 192. Since the rotor winding forms a closed

circuit, the generated e.m.fs. will cause currents to flow in the rotor bars.

The frequency of the e.m.fs. generated in the stationary rotor bars by the revolving field = $\frac{p \times \text{syn. r. p.m.}}{120}$, see page 195, which is the same as the frequency of the e.m.f. applied to the stator, since the syn. speed = $\frac{f \times 120}{p}$, see page 287, so that the frequency of the rotor currents is high, and the reactance of the rotor, which is proportional to the rotor frequency, is large compared with the rotor resistance, the rotor current in each bar therefore lags considerably behind the e.m.f. in that bar. In conductor *a* for example, the e.m.f. has just reached its maximum value, but the current in that conductor lags the e.m.f. by an angle θ which is almost 90 degrees and so does not become a maximum until the poles have moved into the position shown in Fig. 338, which is almost 90 degrees from the position shown in Fig. 337.

Since the conductors in Fig. 338 are carrying current and are in a magnetic field, they are acted on by forces, the direction of which may be determined by the left-hand rule, from which it is found that while the force in the belts *bc* and *de* tends to make the rotor follow the revolving field, that on the conductors in the belts *cd* and *be* acts in the opposite direction. The former force is the larger, so that the rotor tends to follow the revolving field.

The current in the rotor conductors at standstill

$$= \frac{\text{rotor voltage at standstill}}{\text{rotor impedance at standstill}}$$

and the rotor impedance is large enough to limit the current to about five times the full-load value. On account of the large torque opposing the starting of the rotor, this large starting current produces an effective starting torque which seldom exceeds one and a half times the full-load torque of the motor.

314. The Wound Rotor Motor.—The starting torque for a given current can be increased if that current is brought more in phase with the e.m.f. This may be seen from Fig. 339 in which the current lags by such a small angle θ that there is practically no opposing torque.

The angle of lag in a circuit may be decreased by increasing the resistance of the circuit without changing the value of the react-

ance. In Fig. 340 for example, when the resistance R is increased, the vector diagram changes from A to B ; the current I is decreased and so also is the angle θ . If then sufficient resist-

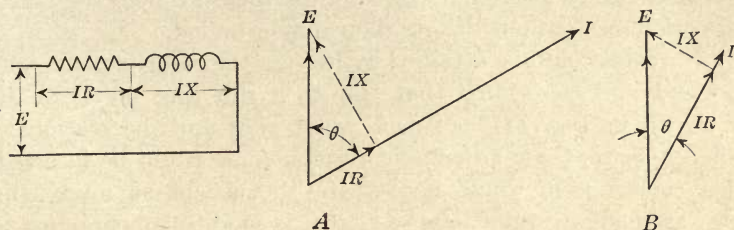

FIG. 340.—Effect of resistance on the magnitude and on the phase angle of current in a series circuit.

ance is put into the rotor bars to reduce the starting current to the full-load value, the angle of lag of the rotor currents will be so small that the torque is all effective, and full-load torque is

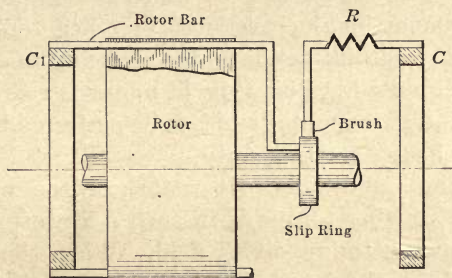

FIG. 341.—Squirrel-cage rotor with bars that have an adjustable resistance.

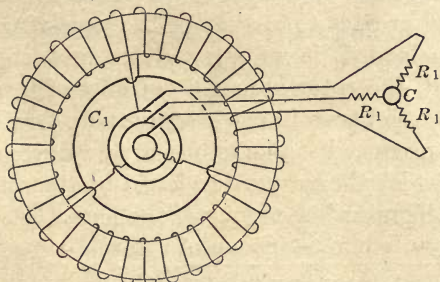

FIG. 342.—Wound rotor.

developed with full-load current. By using a lower resistance, twice full-load torque may be obtained with about twice full-load current.

When a motor is running under load, a large rotor resistance is undesirable because it causes large copper loss, low efficiency and excessive heating, so that some method must be devised whereby resistance can be inserted in the rotor conductors during the starting period and cut out during the running period.

This result could be attained by leaving the rotor bars open at one end and connecting that end to a slip ring on the shaft, as shown in Fig. 341, between which ring and the stationary end connector C an adjustable resistance R could be inserted. This construction would necessitate the use of as many slip rings as there are rotor bars so that it is modified in practice to reduce the number of slip rings.

The bars are connected so as to form a winding of three groups, as shown diagrammatically in Fig. 342. One end of each group is connected to the end connector C_1 , while the free ends are connected to slip rings and then through adjustable resistances R_1 to the other end connector C , which is now merely a short piece of wire connecting the resistances together. The resistances R_1 are gradually cut out as the motor comes up to speed, and are finally short-circuited. This type of motor is called the wound rotor type of induction motor and is to be preferred to the squirrel cage type for heavy starting duty.

315. Running Conditions.—It was shown on page 288 that the resultant starting torque is in such a direction as to make the rotor follow up the revolving field. When the motor is not carrying any load, the rotor will revolve at practically the speed of the revolving field, that is at synchronous speed; it can never run at a speed greater than that of the revolving field. If the motor is then loaded, it will slow down and slip through the revolving field, the rotor bars will cut lines of force, the e. m. fs. generated in these bars will cause currents to flow in them and a torque will be produced. The rotor will slow down until the point is reached at which the torque developed by the rotor is sufficient to overcome the retarding torque of the load.

The ratio $\frac{\text{syn. r.p.m.} - \text{r.p.m. of rotor}}{\text{syn. r.p.m.}}$ is called the per cent.

slip, and is represented by the symbol s , its value at full-load is generally about 4 per cent., that is, when the revolving field make one revolution, the rotor makes 0.96 of a revolution and the field moves relative to the rotor bars through 0.04 of a revolution.

When the rotor is at standstill, the rotor frequency is f cycles per second, see page 288, where f is the frequency of the e.m.f. applied to the stator, but at full-load the rotor frequency is only sf cycles per second because then the velocity of the field relative to the rotor is only s per cent. of the relative velocity at standstill.

As the load on the motor increases, the motor slows down and the rotor slips more rapidly through the revolving field and causes the rotor current to increase, but the frequency of the rotor current increases as well as its numerical value and this causes the rotor reactance to increase and the current to lag. Now the torque developed by the rotor tends to increase due to the increase in the rotor current and to decrease due to the increase in the

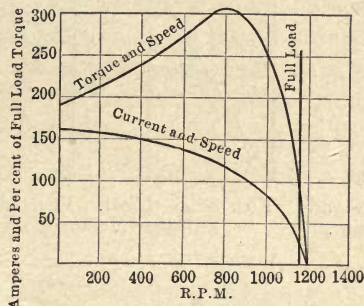

Starting current = 160 amp. = 5 times full load current
 Starting torque = 1.9 times full load torque
 Maximum torque = 3.1 times full load torque

FIG. 343.—The relation between torque, current and speed in a 25 h.p., 440 volt, 3-phase, 60 cycle induction motor.

current lag, see page 288. Up to a certain point, called the break-down point or point of maximum torque, the effect of the current is greater than that of the current lag, beyond that point the effect of the current lag is the greater, so that, after the break-down point is passed, the torque actually decreases even although the current is increasing. The relation between speed, torque and current is shown in Fig. 343 for a 25-h.p., 440 volt, three-phase, 60-cycle, 1200 syn. r.p.m induction motor.

316. Vector Diagrams for the Induction Motor.—*a.* No-load conditions. Alternating e.m.fs. E_1 , applied to the stator, cause alternating currents I_0 to flow in the stator windings and produce the revolving field ϕ , but no work is done if the no-load losses are neglected, so that the current flowing in each phase must lag the voltage applied to that phase by 90 degrees, as

shown in Fig. 344. This no-load current is kept as small as possible by the use of a small air gap clearance between the stator and rotor; a 50-h.p., 900-r.p.m. induction motor will have a rotor diameter of 20 in. (51 cm.) and an air gap clearance of 0.03 in. (0.075 cm.) and, in spite of this small air gap, the magnetizing current I_0 will not be less than 30 per cent. of full-load current.

The revolving field, in addition to cutting the rotor conductors, cuts also those of the stator and generates an e.m.f. E_{1b} , called the

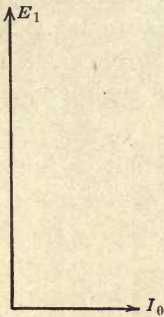

FIG. 344.—No-load vector diagram.

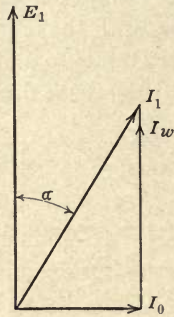

FIG. 345.—Ideal Full-load vector diagrams.

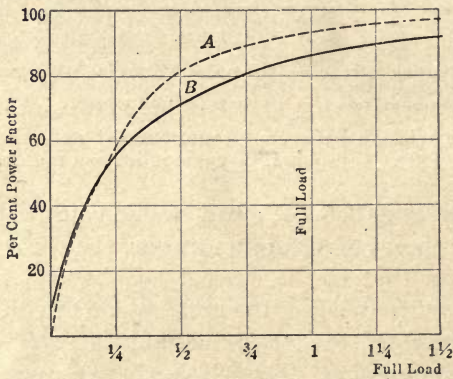
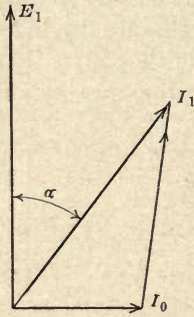

FIG. 347.—The power factor of an induction motor.

back e.m.f., in each phase of the stator winding. E_{1b} is less than E_1 by the e.m.f. required to send the magnetizing current I_0 through the impedance of the stator winding, which e.m.f. is comparatively small. The revolving field is therefore proportional to the voltage E_1 .

b. Full-load conditions. When the motor is loaded it slows down and current passes through the rotor windings and develops

the driving torque of the machine. This current, like that in the secondary of a transformer, tends to demagnetize the machine or to oppose the flux which produces it, but a reduction in the flux ϕ causes the back e.m.f. E_{1b} to decrease and allow a larger current to flow in the primary or stator winding, so that the stator current always adjusts itself to suit the requirements of the secondary or rotor.

The reduction in the value of ϕ is comparatively small, so that at full-load, a magnetizing component of current I_0 is still required to produce the revolving field while a power component I_w in phase with the applied voltage is required for the load, as shown in Fig. 345. The power factor of an induction motor, namely, the $\cos \alpha$, is therefore practically zero at no-load and gradually increases as the load increases, as shown in curve *A*, Fig. 347.

Due to the reactance of the stator winding, and to that of the rotor winding which, as pointed out on page 291, increases with the load, the current lags more than shown in Fig. 345 and the power factor in an actual machine changes with the load as shown in curve *B*.

317. Adjustable Speed Operation.—The squirrel cage motor is essentially a constant speed machine. For adjustable speed operation the wound rotor motor must be used. If such a motor is operating with a load having a constant torque, and a resistance is inserted in the rotor circuit, the rotor current will decrease and the motor will not be able to develop the necessary torque and so will slow down. As the speed drops however the rotor slips more rapidly through the revolving field, so that a greater e.m.f. is induced in the rotor conductors and the current increases, and, at some lower speed, is again sufficient for the load.

The speed regulation however is very poor because, if the load were decreased, less current would be required, and the motor would automatically speed up so as to reduce the slip and thereby reduce the rotor voltage and current. At no-load, the rotor current being then very small, the slip would be practically zero and the motor would run at practically synchronous speed. This method of speed control is therefore similar to that of a direct-current shunt motor with resistance in the armature circuit and has the objection that the speed regulation is poor and the efficiency is low.

Where good speed regulation is desired, the stator may be supplied with two separate windings, one of which is wound so as to

produce a revolving field with p poles and the other a revolving field with p_1 poles and then, by using one or other of these windings, the synchronous speed may be $\frac{120f}{p}$ or $\frac{120f}{p_1}$. It is seldom possible on account of expense to put more than two such windings on one stator.

318. Induction Generator.—Suppose that an electric car driven by an induction motor is operating on a road where there is a long pull up followed by a long coast down. When on the up-grade, the motor runs at about 4 per cent. less than synchronous speed, at which speed the rotor slips fast enough through the revolving field to cause full-load current to flow.

Starting on the down grade, the car begins to drive the motor and the speed of the motor first becomes equal to the synchronous speed, when the rotor current is zero, and then runs at a speed which is greater than synchronous so that the rotor is again slip-

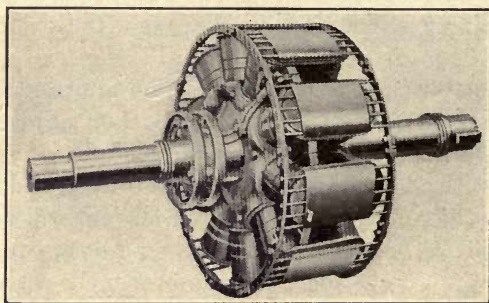

FIG. 348.—The rotor of a self-starting synchronous motor.

ping through the revolving field. But since it is now running faster than the field, the direction of motion of the conductors relative to the field has been reversed, and the torque which was a driving torque now becomes a retarding torque so that the machine is now acting as a generator and delivering power to the mains. When the speed is about 4 per cent. above synchronous speed, the machine will be delivering full-load as a generator.

319. Self-starting Synchronous Motors.—Polyphase synchronous motors have stators which are exactly the same as those of induction motors, they may therefore be made self starting if a squirrel cage winding is added to the rotor as shown in Fig. 348.

If alternating e.m.fs. are applied to the stator of such a machine, the field coils not being excited, the machine will start up as an induction motor and will attain practically synchronous speed. If the field coils are then excited, the machine will be pulled into synchronism.

The single-phase synchronous motor cannot be made self starting in this way because, as shown on page 308, the single-phase induction motor is not self starting.

320. Dampers for Synchronous Machines.—In addition to making a synchronous machine self starting, the squirrel cage acts as a damper to prevent hunting, see page 259.

A machine which is hunting is moving at a speed which is alternately slower and faster than the synchronous speed, and, in each case, the squirrel cage rotor cuts lines of force. A driving torque is produced as in an induction motor when the machine is running below synchronous speed, and this tends to speed it up, while a retarding torque is produced as in an induction generator when the machine is running above synchronous speed, and this tends to slow it down. When the machine is running at synchronous speed there is no current in the squirrel cage. The torque due to the squirrel cage therefore tends at all times to prevent oscillations in speed and therefore to prevent hunting.

CHAPTER XXXVII

INDUCTION MOTOR APPLICATIONS AND CONTROL

321. Choice of Type of Motor.—The synchronous motor is the only motor whose power factor can be controlled. Such a machine may be overexcited and made to draw a leading current from the line so as to raise the average power factor of the total load connected to the line and thereby allow the use of a smaller alternator and a smaller cross section of copper in the transmission line than would be required for a load consisting entirely of induction motors, see page 257.

The synchronous motor runs at a constant speed at all loads. It suffers from two disadvantages, namely, that the starting torque is small even if the motor is of the self-starting type, while direct current is necessary to excite the field magnets. Because of these disadvantages it is used only in large sizes and only when the starting torque required is small as, for example, for the driving of large constant speed fans, pumps, and air compressors, when the load can be relieved during the starting period; it is also much used as the motor end of a motor generator set, see page 318.

The **single-phase machines** described in the next chapter are more expensive than polyphase machines of the same output and are not used for general power work. They are used in comparatively small sizes where polyphase current is not available.

The polyphase induction motor is used for practically all the power work when only alternating current is available, care must be taken however to use the proper type.

The **squirrel-cage induction motor** takes a lagging current and has a full-load power factor of about 80 per cent. for a 1 h.p. motor and 90 per cent. for a 100 h.p. machine.

It is available only with the following speeds

Poles	On 25-cycle mains	On 60-cycle mains
2	1500 r.p.m.	3600 r.p.m.
4	750 r.p.m.	1800 r.p.m.
6	500 r.p.m.	1200 r.p.m.
8	375 r.p.m.	900 r.p.m.
10	300 r.p.m.	720 r.p.m.
p	120×25 r.p.m.	120×60 r.p.m.
	p	p

The full-load speed is about 4 per cent. lower than the above.

The principal objection to the squirrel-cage motor is that it takes a large starting current to develop a moderate starting torque. About 5 times full-load current is required to give 1.5 times full-load torque or, with reduced voltage, see page 302, 3.3 times full-load current for full-load torque. The motor is therefore not suitable for heavy starting duty.

It is very rugged, has no sliding contacts, and is the most satisfactory constant speed motor for loads that do not require a large starting torque.

The wound rotor induction motor has the same running characteristics as the squirrel-cage motor, but has better starting characteristics and will develop full-load torque at starting with full-load current in the line.

The service for which each of these induction motors is suited can best be illustrated by a few typical examples.

322. A line shaft should run at practically constant speed at all loads and may be driven by a squirrel-cage motor if there are not many countershaft belts, or if loose pulleys are used to take the load off the motor during the starting period. If the starting torque required exceeds full-load torque then a wound rotor type of motor must be used.

323. Wood-working machinery such as planers and saws are driven by squirrel-cage motors, except in the case of certain types of heavy planing mills which have a large inertia and require the large starting torque developed by the wound rotor motor.

324. Cement Mills.—The squirrel-cage motor is used for the driving of cement machinery because it has no sliding contacts; the commutator of a direct-current motor or the slip rings of a wound rotor motor would wear very rapidly in a cement mill.

To obtain the high starting torque required for some of the machines, a large resistance must be inserted in the rotor circuit, see page 289. In the case of the squirrel cage motor this is done

by making the rotor end connectors of high resistance metal. The resistance in this case remains permanently in the circuit and causes the efficiency at full-load to be about 5 per cent. lower than it would be with a wound rotor motor, since this latter machine is so constructed that the resistance can be cut out when the motor is up to speed.

325. Motors for Textile Machinery.—The quality of the finished product of a loom depends largely on the constancy of the motor speed and for such service induction motors are preferred to direct-current motors because their speed depends only on the frequency of the power supply and is not affected by variations of the applied voltage.

326. Adjustable Speed Motors.—A wound rotor induction motor with the rotor short-circuited drops about 4 per cent. in

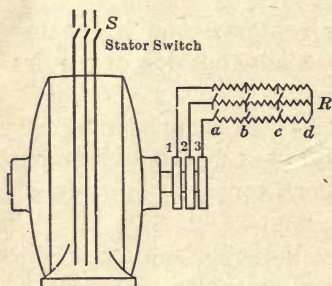

FIG. 349.

Effect of rotor resistance on the speed of an induction motor.

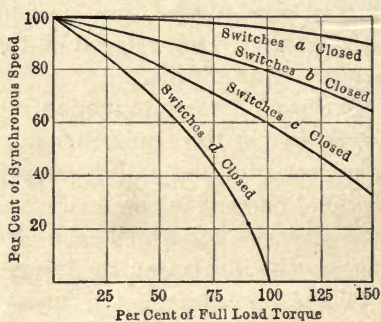

FIG. 350.

speed between no-load and full-load, as shown in curve *a*, Fig. 350.

When resistance is inserted in the rotor circuit, as shown in Fig. 349, the motor will drop in speed so as to generate the larger e.m.f. required to send the current through this higher resistance. At no-load however the rotor will run at practically synchronous speed because only a small slip is required to generate enough e.m.f. to send the no-load current through the rotor. Curves *b* and *c*, Fig. 350, are the speed curves with different values of rotor resistance; the larger the drop in speed required, the larger the rotor resistance must be, and the greater the loss in this resistance.

327. Crane motors should be able to develop a large starting torque without taking an excessive current from the line; they

should run at a slow speed when the load to be lifted is heavy and at a high speed when the load is light.

Large starting torque may be obtained by inserting resistance in the rotor circuit. By this means full-load torque may be obtained at starting with full-load current in the line, and twice full-load starting torque with about twice full-load current, see page 289.

A drooping speed characteristic such as that in curve *c*, Fig. 350, is also obtained by inserting resistance in the rotor circuit.

Crane motors in small sizes are generally of the squirrel cage type, the high rotor resistance being obtained by making the rotor end connectors of high resistance metal. This gives a very simple type of machine but, because of the large rotor resistance and therefore the large rotor resistance loss, the machine heats up quickly. For outputs greater than 20 h.p. it is therefore advisable to use the wound rotor type of machine in which case the resistance is outside of the machine and can be varied as desired.

Crane operation by means of induction motors is not so efficient as the operation by direct-current series motors, since these latter machines have the desired characteristics without the use of additional resistance, see page 103.

328. Shears and punch presses are generally supplied with a flywheel to carry the peak load. In order that the flywheel may be effective, the speed of the motor must drop as the load comes on. A standard machine drops in speed about 4 per cent. between no-load and full-load. For a larger drop in speed, resistance must be connected permanently in the rotor circuit so as to give a characteristic such as that shown in curve *b*, Fig. 350. The motor may be a squirrel-cage machine with high resistance end connectors, but for large presses it will often be necessary to use a wound rotor motor to obtain sufficient starting torque to accelerate the flywheel on first starting up.

329. For adjustable speed service such as the driving of lathes and other machine tools, the only alternating-current motor at present available is the wound rotor induction motor.

The speed of such a machine may be lowered for a given torque by inserting resistance in the rotor circuit as shown in Fig. 349, and the speed characteristics with different values of resistance are shown in Fig. 350.

Because of the use of this resistance, there is a large resistance loss which increases as the speed is decreased, so that the efficiency

of an induction motor at reduced speed is low. Moreover the speed regulation is poor, as shown by curves *b* and *c*, Fig. 350. If for example an induction motor operating at reduced speed is driving a lathe in which a forging such as that in Fig. 129, page 108, is being turned, then the motor will slow down when the cut is deep and will speed up when the cut is light, so that the speed will be very irregular.

For machine tool driving then the alternating-current motor is not such a suitable machine as the direct-current shunt motor controlled by field resistance, see Arts 126 and 127, page 107, and it has been pointed out that for crane service the direct-current motor is superior to the alternating-current motor, so that, when the bulk of the load consists of adjustable speed or crane motors, direct current should be supplied even if it is necessary to use a motor generator set, see page 318, to change from alternating to direct current.

330. Resistance for Adjustable Speed Motors.—As in the case of the direct-current motor, the number of ohms in the controlling rheostat and the current carrying capacity of the resistors depends on the service for which the motor has to be used.

If a fan and a reciprocating pump take 10 h.p. at full speed, then at half speed the pump takes 5 h.p. since the torque is constant, while the fan takes $\sqrt[3]{10}=2.15$ h.p., see page 111, the rotor current of the fan motor will therefore be less at half speed than that of the pump motor. The voltage generated in the rotor by the revolving field, however, will be the same in each case, so that the number of ohms in the fan rheostat must be greater than the number in the pump rheostat so as to reduce the current to the lower value.

STARTERS AND CONTROLLERS

331. Switches for Alternating-current Circuits.—It causes less arcing to open a circuit in which alternating current is flowing than to open one in which direct-current is flowing, because, in the former case, the current passes through zero twice every cycle.

The quick break type of switch, see page 114, is used for small currents. For larger currents or in high-voltage circuits the contacts are immersed in insulating oil which quenches any arc that forms. The oil switch in alternating-current circuits takes

the place of the magnetic blow-out switches used in direct-current circuits.

332. Starting of Squirrel-cage Induction Motors.—A squirrel cage motor at standstill takes about 5 times full-load current from the line with normal applied voltage, and develops about 1.5 times full-load torque.

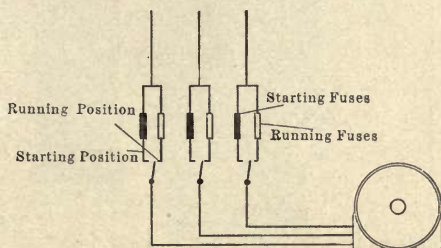

FIG. 351.—Connections for a small three-phase, squirrel-cage induction motor.

Motors with an output of 5 h.p. or less are generally connected directly to the line without a starter, by means of a double-throw switch such as that shown diagrammatically in Fig. 351. This switch is so constructed that it will stay in the starting position only when held there against the tension of a spring.

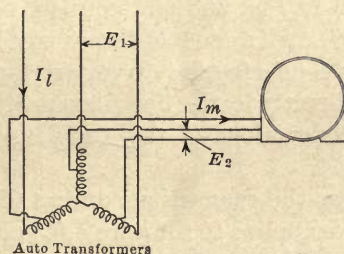

FIG. 352.—Connections of a starting compensator for a three-phase, squirrel-cage induction motor.

Motors with an output which is greater than 5 h.p. are generally started up on reduced voltage by means of autotransformers connected as shown in Fig. 352. By this means the starting current is reduced, but the starting torque also is reduced; the revolving field ϕ is proportional to the applied voltage E which produces it, see page 292, while the rotor current I_2 is proportional to the revolving field ϕ by which it is produced, so that the start-

ing torque, being proportional to $\phi \times I_2$ is proportional to ϕ^2 and therefore to E^2 .

A motor at standstill takes 5 times full-load current with normal applied voltage and develops 1.5 times full-load torque. - What must the applied voltage be to obtain full-load torque and what will be the starting currents in the motor winding and in the line?

$$\frac{(E_2)^2}{(E_1)^2} = \frac{\text{full-load torque}}{1.5 \text{ full-load torque}} = \frac{1}{1.5}$$

therefore
$$E_2 = \sqrt{\frac{1}{1.5}} \times E_1$$

$$= 0.815E_1$$

or 81.5 per cent. of normal voltage

The starting current in the motor = 5 (full-load current) $\frac{E_2}{E_1}$

$$= 4.1 \text{ (full-load current)}$$

$$= I_m, \text{ Fig. 352.}$$

The starting current in the line = 4.1 (full-load current) $\frac{E_2}{E_1}$

$$= 3.3 \text{ (full-load current)}$$

$$= I_l, \text{ Fig. 352.}$$

333. Starting Compensator.—The combined autotransformers and switches constitute what is called a starting compensator. One type is shown in Fig. 353 and consists essentially of three autotransformers T and a double-throw switch S by means of which the motor is connected to low-voltage taps for starting and is then connected directly to the line when nearly up to full speed.

The complete connections of this compensator are shown in diagram A , Fig. 354.

Diagram B shows the connections during the starting period; normal voltage E_1 is applied to the lines a, b , and c while a reduced voltage E_2 is tapped off from the autotransformers and is applied to the motor.

Diagram C shows the connections during the running period. The voltage applied to the motor is now normal and the overload relays O are connected in the circuit while the no-voltage release coil M is connected across one leg of the circuit.

The no-voltage release feature is similar in principle to that used on starters for direct-current motors, see page 120, and consists of a latching solenoid which holds the starting arm against the tension of a spring. When the line voltage fails, the solenoid

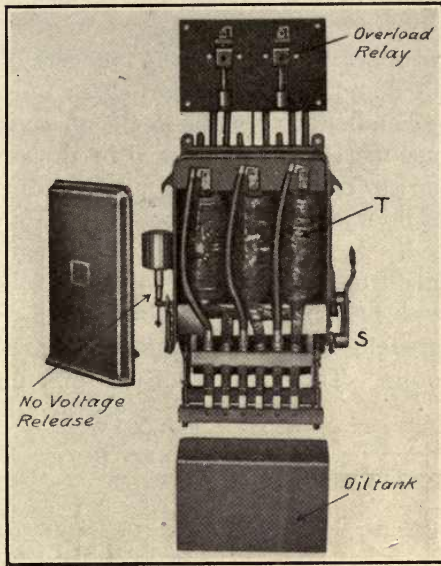

FIG. 353.—Starting compensator for a three-phase induction motor.

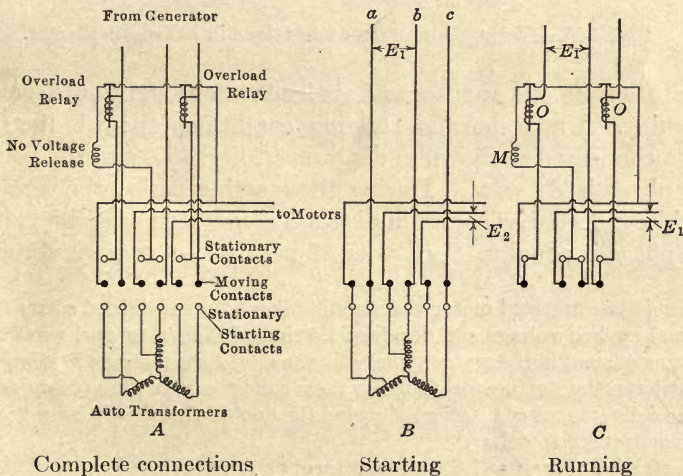

FIG. 354.—Diagram of connections of a three-phase starting compensator.

M is deenergized and the starting handle then returns to the off position.

In the case of a heavy overload, the plungers of the overload relays O are raised and open the circuit of the no-voltage release M , the starting handle then returns to the off position.

The no-voltage release is not supplied in all cases because an induction motor can carry a starting current of 5 times full-load current without injury during the short interval of time taken to attain full speed. As a rule, the only objection to this large current is the disturbance it causes due to the opening of circuit breakers.

334. The star-delta method of starting is sometimes used for three-phase motors. The windings of the three phases are kept

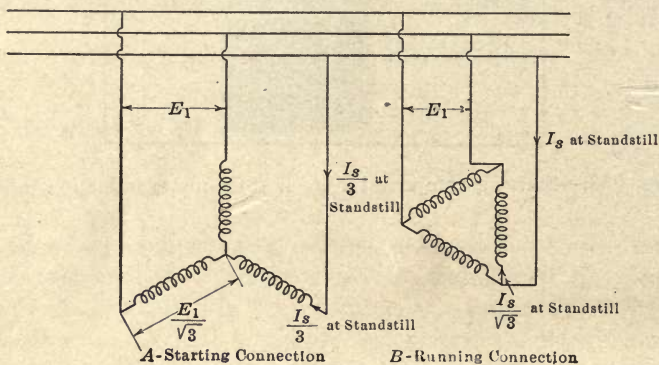

FIG. 355.—Voltage and current relations in a Y-delta starter.

separate from one another and six leads are brought out from the machine. Under normal running conditions the windings are delta connected as shown in diagram B , Fig. 355, and the voltage per phase is E_1 volts. During the starting period the windings are Y-connected as shown in diagram A in which case the voltage per phase is equal to $E_1/1.73$ or 58 per cent. of normal voltage.

If a delta-connected motor at standstill takes 5 times full-load current with normal applied voltage and develops 1.5 times full-load torque, what is the starting current in the motor and also in the line, if the motor is Y-connected, and what is the starting torque under these conditions? (The student should make a diagram of connections showing the double-throw switch required to change from Y to delta.)

$$\begin{aligned} \text{The starting torque} &= 1.5 \text{ (full-load torque)} \times (0.58)^2 \\ &= 0.5 \text{ (full-load torque)} \end{aligned}$$

The starting current in the line when delta connected	$= I_s$
The starting current in the motor when delta connected	$= I_s/\sqrt{3}$
The starting current in the motor when Y-connected	$= (I_s/\sqrt{3}) \times 0.58$
	$= I_s/3$
The starting current in the line when Y-connected	$= I_s/3$

Now I_s is 5 times full-load current, so that, when the motor is Y-connected, the starting current in the line is $1/3 \times 5$ or 1.67 times full-load current. The starting torque, however, is only 0.5 times full-load torque and, if this is not sufficient to start the motor with the load, then a starting compensator will be required.

335. Starter for a Wound Rotor Motor.—To start up a motor of this type the main switch S , Fig. 349, is closed and then the

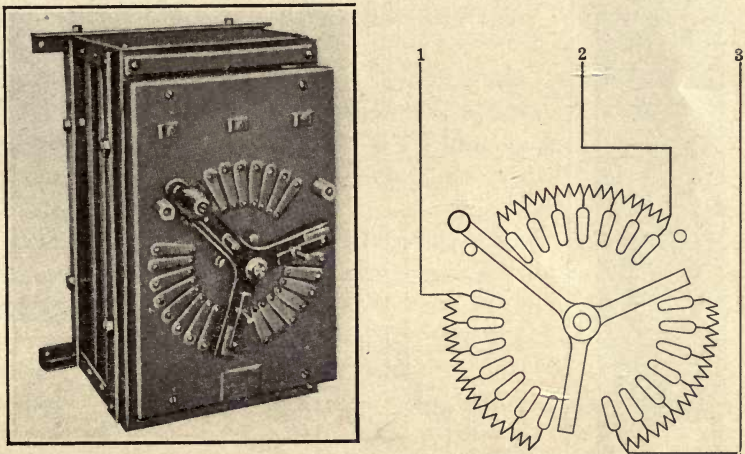

FIG. 356.—Sliding contact type of starter for a wound-rotor induction motor.

resistance R in the rotor circuit is gradually cut out as the motor comes up to speed.

Since the rotor is wound in three sections, see page 290, three sets of contacts are required which for small motors are generally mounted on a faceplate as shown in Fig. 356. This starter may be used as a speed regulator if the resistance has sufficient current carrying capacity.

For motors larger than about 50 h.p., the multiple switch type of starter, see page 119, is generally preferred. Such a starter for the motor shown diagrammatically in Fig. 357 would consist of three double-pole switches so interlocked that they can be closed only in the order A, B, C . The switches are held closed

by a latch which is released by the no-voltage release magnet when the voltage fails.

336. Automatic Starters.—Squirrel-cage motors of small output are thrown directly on the line and the self starter for such a motor consists of a single double-pole magnetic switch such as that shown diagrammatically at A, Fig. 357.

If a solenoid were attached to the handle of a starting rheostat such as that in Fig. 356, then a sliding contact type of self starter

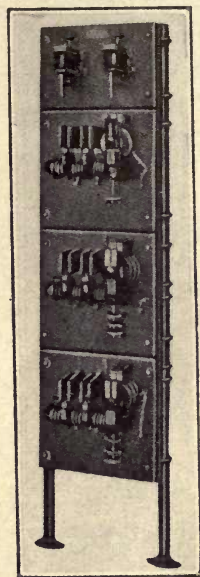

FIG. 359.

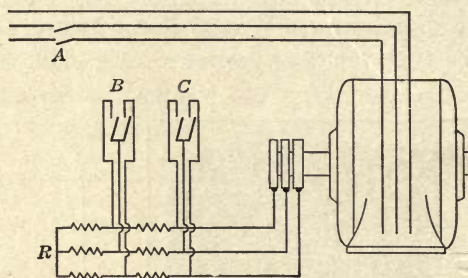

FIG. 357.—Wound rotor type of motor.

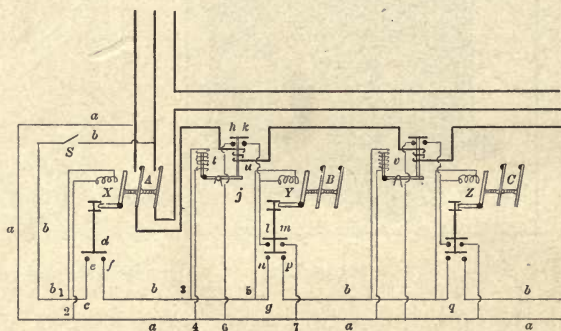

FIG. 358.—Automatic starter for a wound-rotor induction motor.

would be produced similar to the direct-current starter shown in Fig. 154, page 130. If in addition the main starter switch is magnetically operated then the motor may be started from a distance by a control circuit such as that shown in Fig. 156, page 131, this circuit being connected across one of the phases and the magnets being laminated¹ so as to be suitable for operation with alternating currents.

¹ The core of an alternating-current magnet must be laminated for the same reason as a transformer core is laminated, see page 269, namely, to prevent excessive core loss due to the alternating magnetic flux.

For large motors, the multiple switch type of starter is used, by means of which the switches *A*, *B* and *C*, Fig. 357 are closed in their proper order and the motor thereby brought up to speed without the starting current exceeding a predetermined value. The principle of operation is the same as for the direct-current starter described in Art. 158, page 133, although the mechanical details are different.

Fig. 358 shows the control circuit for the three switches *A*, *B* and *C* in Fig. 357. When the control switch *s* is closed, the line *b* is excited as far as point *c*, and the magnet *X*, connected between points 1 and 2, closes the double contactor switch *A*. The motor then starts up with all the rotor resistance *R*, Fig. 357, in the circuit, while about one and a half times full-load current flows in the lines.

When switch *A* closes, the disc *d* drops, closes the contacts *e* and *f*, and extends the excited part of line *b* as far as *g*. The coil *t* is now excited from the points 3 and 4 and its plunger is lifted, thereby tilting the lever *j* to which it is attached and removing the support of the plunger of coil *u*. The line current passing around *u* however holds up this plunger until the motor has attained about one-third of normal speed and the current has decreased to about full-load value when the plunger of *u* drops and closes the contacts *h* and *k*. The coil *Y* is now excited from the points 5 and 6 and closes the double-pole switch *B* thereby cutting out the first step of the resistance from each leg of the rheostat. The current then increases to about 1.5 times full-load current but gradually decreases as the motor speeds up further.

As soon as switch *B* closes, the interlock discs attached to that switch are lowered, and the contact *lm* is closed, so that coil *Y* is now excited from the points 5 and 7 and the switch *B* is therefore held closed independently of the plunger of coil *u*. The contact *np* is closed at the same instant by the lower interlock disc and the excited part of line *b* is thereby extended as far as *q*, and the same series of operations is repeated before switch *C* closes.

Fig. 359 shows the complete starter, with the relays *t* and *v* on the top panel and the switches *A*, *B* and *C* on the lower panels.

CHAPTER XXXVIII

SINGLE-PHASE MOTORS

337. Single-phase Induction Motors.—If one of the phases of a two-phase induction motor is opened while the motor is running, the machine will continue to rotate and carry the load.

A two-pole single-phase induction motor at standstill is shown diagrammatically in Fig. 360. When an alternating current flows in the winding A , an alternating flux ϕ is produced. Since this magnetic field is not rotating, there is no tendency for the rotor to turn, so that the machine is not self starting.

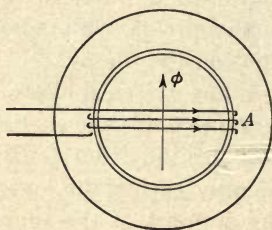

FIG. 360.—Diagrammatic representation of a single-phase induction motor.

338. Split-phase Method of Starting.—One of the many methods used to obtain a rotating field from a single-phase supply is shown diagrammatically in Fig. 361. The motor is wound as for two-phase operation, and a resistance R is inserted in series with the winding A . The current I_a therefore does not lag as much as the current I_b , and the resultant magnetic field of the motor has a rotating component which will cause the rotor to turn.

If, in addition to the resistance R , a condenser C is inserted in series with the winding A , then the current I_a may be made to lead the voltage E . The currents I_a and I_b will then be more nearly 90 degrees out of phase, and the operation of the motor will be more nearly that of a two-phase machine.

This method of starting is called the split-phase method.

339. Running Torque of a Single-phase Motor.—If, as in Fig. 363, two equal vectors P rotate with the same velocity but in opposite directions, the resultant vector R alternates between the values $R = 2P$ and $R = -2P$, and always lies in the line joining these two points.

An alternating magnetic flux ϕ , such as that in Fig. 362, is therefore equivalent to two rotating fields ϕ_x and ϕ_y which are of

equal strength and rotate in opposite directions with the same velocity. These fields tend to start the rotor in opposite directions, so that the resultant starting torque is zero.

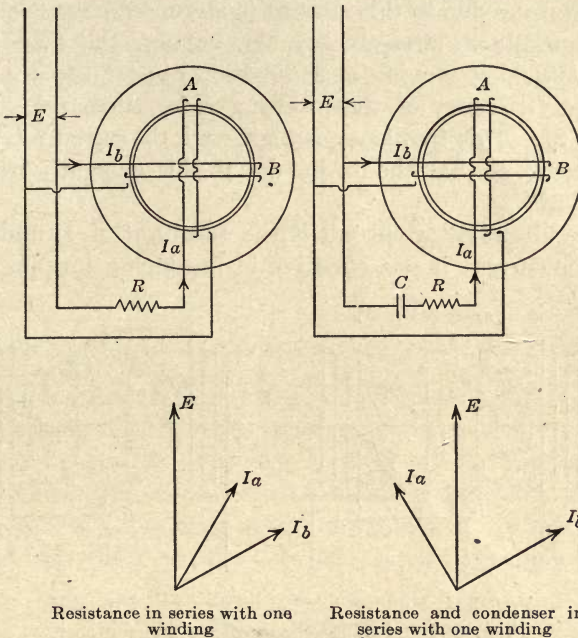

FIG. 361.—Split-phase connections for a single-phase induction motor.

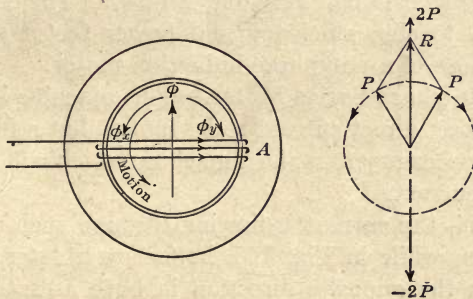

FIG. 362.

FIG. 363

FIGS. 362 and 363.—Resolution of an alternating field into two revolving components.

Suppose that the rotor has been started by phase-splitting and is running in the direction of the field ϕ_x with a speed which is little less than synchronous speed. The rotor bars will then be cutting the field ϕ_x , and an e.m.f. will be induced which will send

through these bars a current I_x of frequency sf , see page 291, where s is the per cent. slip and f is the applied frequency. Since this rotor frequency is low, the current lags by a very small angle, and the torque due to this current is large, see page 288.

The rotor bars, however, are also cutting the field ϕ_y , and, since this field is moving in a direction opposite to that of the rotor, the frequency of the resulting rotor current I_y is almost equal to $2f$. This frequency is high, and the current I_y lags by a large angle, so that the torque due to this current is negligible, see page 288.

The resultant rotor current is the resultant of I_x and I_y , but the latter current is not effective in producing torque, and the

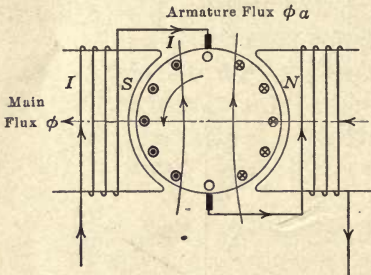

FIG. 364.

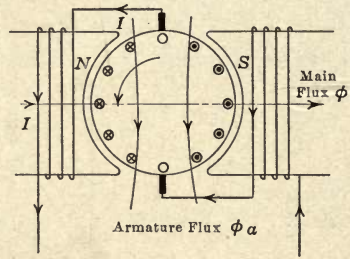

FIG. 365.

FIGS. 364 and 365.—Single-phase series motor.

machine runs as if it had only one field ϕ_x . The characteristics with respect to slip, efficiency and power factor are therefore similar to those of a polyphase induction motor.

340. Single-phase Series Motor.—This machine is wound and connected like a direct-current series motor, but a few structural changes are necessary to make a machine which will operate with alternating current.

In Fig. 364, the current is flowing through such a machine in one direction, while in Fig. 365, half a cycle later, the current is flowing in the opposite direction in both armature and field coils, but the direction of the torque is unchanged.

The characteristics of this machine are similar to those of the direct-current series motor. The torque is approximately proportional to the square of the current, since torque = $K\phi I$, where the flux ϕ is proportional to the current I . The torque, however, is pulsating, being a maximum when the current is a maximum and zero when the current is zero, but the average

torque is the same as would be produced by a direct current of the same magnitude.

Since the magnetic flux in the poles is alternating, the field structure must be laminated to keep the eddy current loss small. Due to this alternating flux, a voltage E_f of self induction is induced in the field coils, to overcome which the applied voltage must have a component E_f , Fig. 366.

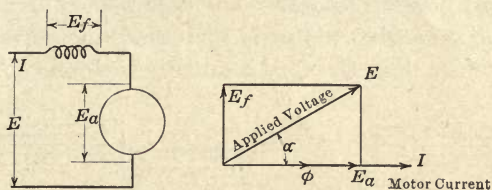

FIG. 366.—Vector diagram for a single-phase series motor.

Since the armature is rotating in a magnetic field, a back e.m.f. is generated in the armature in the same way as in a direct-current motor, see page 79. This e.m.f., however, is alternating since it is produced by the cutting of an alternating flux ϕ . It is a maximum when the flux is a maximum and zero when the flux is zero, so that, to overcome this back e.m.f., the applied voltage

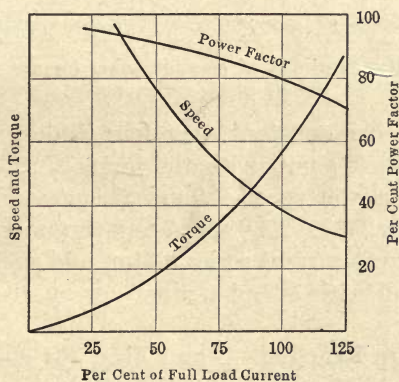

FIG. 367.—Characteristics of a single-phase series motor.

must have a component E_a in phase with the flux ϕ and therefore in phase with the current I .

In Fig. 366, then

ϕ is the alternating magnetic flux

I is the current in the machine

E_a is the component of voltage to overcome the back e.m.f.

E_f is the component of e.m.f. to send the current I through the self induction of the field coils

E , the resultant of E_a and E_f , is the applied voltage

$\cos \alpha$ is the power factor of the motor.

The lower the frequency of the supply, the smaller the value of E_f ; and the higher the speed of the motor, the larger the value of E_a , so that low frequency and high speed are the conditions for high power factor.

If the load on such a motor is increased, the current increases and so therefore does the flux ϕ and the voltage E_f . Since the

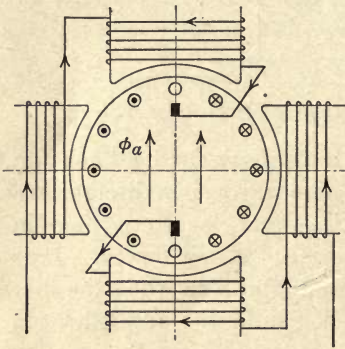

FIG. 368.—Conductively compensated.

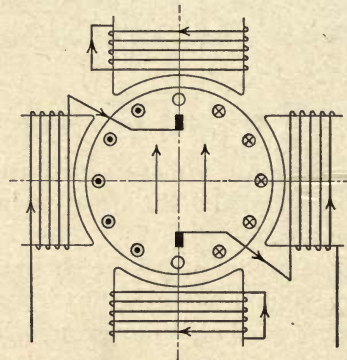

FIG. 369.—Inductively compensated.

Figs. 368 and 369.—Methods of compensating for armature reaction in a single-phase series motor.

applied voltage E is constant, therefore E_a decreases slightly; to generate this back e.m.f. with the larger flux ϕ , the armature must run at a slower speed. Typical curves for such a motor are shown in Fig. 367. The speed and torque curves are similar to those of a direct-current series motor, and such a machine will run equally well with either a direct- or an alternating-current supply.

341. Armature Reaction.—From Figs. 364 and 365 it may be seen that there is a cross magnetizing effect due to the armature current just as in the direct-current machine, but this cross flux ϕ_a is alternating and generates an e.m.f. of self induction in the armature coils which tends to lower the power factor, because self induction always tends to make the current lag. This cross flux is eliminated by means of a compensating winding connected as shown in Fig. 368 so that its magnetizing effect at every instant is exactly equal and opposite to that of the armature.

Another method of eliminating the cross flux ϕ_a is shown diagrammatically in Fig. 369. In this case the compensating coils are short circuited. The flux ϕ_a threads these coils and generates in them an e.m.f. which, according to Lenz's law, sends a current in such a direction as to oppose the change of the flux, so that the cross flux is automatically kept down to a small value.

342. The Repulsion Motor.—If, in the machine shown in Fig. 368, the armature is disconnected from the circuit and is then short circuited, as shown in Fig. 370, the resulting machine is what is called the repulsion motor.

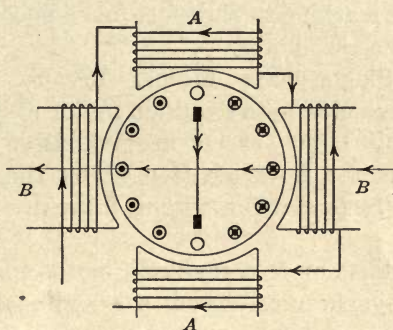

FIG. 370.

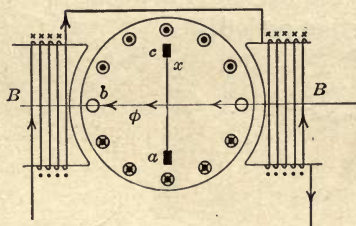

FIG. 371.

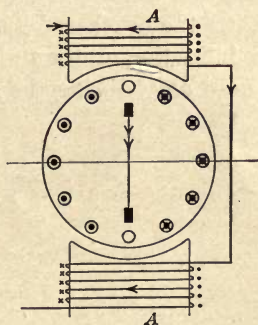

FIG. 372.

Figs. 370 to 372.—The starting torque of a single-phase repulsion motor.

If the coils B alone are acting, as shown in Fig. 371, then e.m.fs. are generated in the armature coils in such a direction as to oppose the change of the flux ϕ , but no current passes through the armature winding or through the conductor x since the voltage between a and b is opposed by that between b and c .

If the coils A alone are acting, as shown in Fig. 372, then a

large current can flow, but the resultant torque is zero because, under each pole, half of the conductors carry current in one direction while the other half carry current in the opposite direction.

If both sets of coils are acting, as in Fig. 376, then the current produced in the armature by coils *A* can produce a torque with the magnetic field produced by coils *B*.

343. Commutation of Series and Repulsion Motors.—The coils which are short circuited by the brushes on the commutator are threaded by an alternating flux ϕ , see Figs. 364 and 370, so that large currents are induced in these coils which currents, flowing through the brush contacts, cause sparking. The commutation of these machines is therefore much poorer than that of the direct-current series motor.

344. Wagner Single-phase Motor.—Because of the poor commutation, the single-phase repulsion motor has not come into extensive use in this country except in small sizes. The principle of the repulsion motor, however, is used by the Wagner company to obtain a large starting torque from a single-phase induction motor.

This machine starts up as a repulsion motor and, when it has attained almost synchronous speed, a centrifugal device short circuits all the commutator bars on one another and at the same time lifts the brushes. The motor operates thereafter as a single-phase induction motor and the commutator has a long life because it is used only during the starting period.

CHAPTER XXXIX

MOTOR-GENERATOR SETS AND ROTARY CONVERTERS

345. Motor-Generator Set.—When it is desired to change from one alternating voltage to another a static transformer is used, see Chap. 34. To change from one direct voltage to another no such simple device is available and a motor-generator set has to be used. This consists of two machines mechanically connected together one of which, running as a motor, takes power from the source of supply and drives the other machine as a generator; this latter machine is wound for the desired voltage.

If 10 kw. at 220 volts is required from a 110 volt line then:
the generator output = 10 kw. at 220 volts

$$\text{the motor output} = \frac{10 \times 1000}{746} \times \frac{1}{0.88} = 15 \text{ horse-power at 110 volts}$$

where the generator efficiency is taken as 88 per cent.

346. The booster set is a special type of motor-generator set and is shown diagrammatically in Fig. 373. The generator in

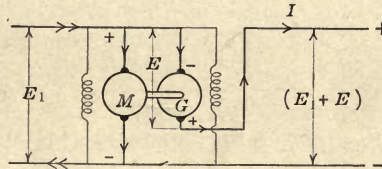

FIG. 373.—Booster motor-generator set.

this case is connected in series with the line and its voltage can add to or subtract from the line voltage.

If 10 kw. at 220 volts is required from a 110 volt line and a booster set is used then:

$$\begin{aligned} \text{the booster output} &= EI, \text{ Fig. 373} \\ &= 5 \text{ kw. at 110 volts} \end{aligned}$$

$$\text{the output of the driving motor} = \frac{5 \times 1000}{746} \times \frac{1}{0.85}$$

$$= 8 \text{ horse-power at 110 volts}$$

and this set can perform the same duty as that performed by the motor-generator set figured out in the last article.

347. The balancer set is a special type of motor-generator set used when it is desired to change from a two-wire to a three-wire direct-current system. As shown diagrammatically in Fig. 374, it consists of two shunt-wound direct-current machines with their armatures on the same shaft, which armatures in the particular case shown, are wound for 110 volts.

Compare now the operation of a three-wire system without a balancer as in Figs. 375 and 377, and with a balancer as in Figs.

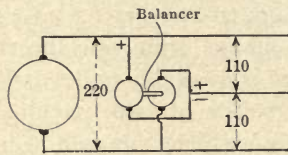

FIG. 374.—Balancer set.

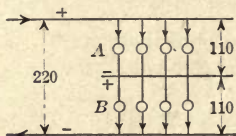

FIG. 375.

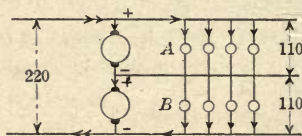

FIG. 376.

FIGS. 375 AND 376.—Balanced load.

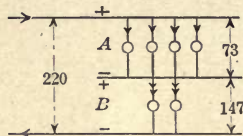

FIG. 377.

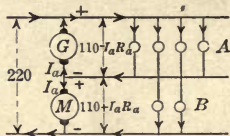

FIG. 378.

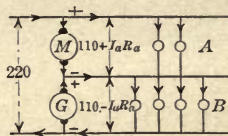

FIG. 379.

FIGS. 377 TO 379.—Unbalanced load.

376 and 378. In the case where the load is equal on the two sides of the system, there is no current in the neutral wire and the balancer in Fig. 376 is running light as two motors in series on 220 volts, while the voltages across the two sides of the system are equal.

If now some of the lamps on the side *B* of the system are switched off then in Fig. 377 the same total current is passing through the lamps connected across *A* as is passing through the smaller number of lamps connected across *B* so that each lamp *B* is carrying more current than each lamp *A* and the voltage across *B* is now greater than that across *A*. In the extreme case when

only one lamp is connected across B the voltage across that lamp is practically 220 volts.

When the balancer is used, as in Fig. 378, the voltages tend to take the same values as in Fig. 377, but when the voltage of B rises and that of A falls then the machine M tries to increase in speed and G to decrease in speed or each machine tries to run as a motor at the speed corresponding to its voltage. But the two machines are coupled together, so that the actual speed must be between these two values and the one that tends to run fast will try to increase in speed and will therefore act as a motor and drive the other machine as a generator, so that G operates as a generator and current passes through it from the negative to the positive terminal while M operates as a motor driving G and

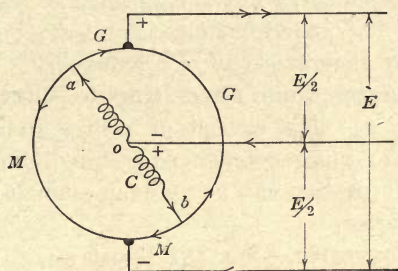

FIG. 380.—Three-wire generator.

current passes through it from the positive to the negative terminal. The voltage across G will be $(110 - I_a R_a)$ volts and that across M will be $(110 + I_a R_a)$ volts, where $I_a R_a$ is the armature resistance drop, and the change in the voltages across the two sides of the system is comparatively small even when the load is considerably unbalanced.

Neglecting the losses in the balancer itself, the generator output and the motor input are each equal to $(110 \text{ volts} \times \text{half the unbalanced current})$, and if care is taken to arrange that the load is nearly balanced under all conditions, then the balancer may be of comparatively small output.

When the load on side B of the system becomes greater than that on side A , the current in the neutral wire flows in the opposite direction, as shown in Fig. 379.

348. Three-wire Generator.—The balancer set is eliminated by the use of the three-wire generator shown diagrammatically in Fig. 380, which consists of a standard two-wire direct-current

generator with a coil C of high reactance and low resistance connected permanently across diametrically opposite points on the armature. The voltage between a and b is alternating, see page 240, so that, even with no external load, an alternating current flows through the coil C , this current, however, is extremely small since the reactance of coil C is large.

The center point o is always midway in potential between a and b and this point is connected to the neutral line of the three-wire system. When the loads on the two sides of the system differ, a current flows in the neutral line and enters the armature through the reactance coil which offers only a small resistance to direct current. The currents in the sections M flow against the generated e.m.f. so that these sections are equivalent to the motor end of a balancer, while the currents in sections G flow in the direction of the generated e.m.f. and so these sections are equivalent to the generator end of a balancer.

349. To transform from alternating to direct current, the motor-generator set may consist of either an induction or a synchronous motor, direct connected to a direct-current generator, The same transformation can be made in a single machine called the rotary converter.

350. Rotary Converter.—Fig. 381 shows an alternator such as that on page 241 connected to a direct-current generator which has the same number of poles. If an alternating e.m.f. is applied to machine M , it will operate as a synchronous motor and direct current may then be obtained from machine G . The two machines M and G may be combined to form a single machine as shown in Fig. 382, and, if an alternating voltage is applied to the slip rings ab , the machine will run as a synchronous motor while at the same time direct current may be obtained from the brushes at the commutator end. The resultant current in the armature will be the difference between the direct current I_d drawn from the machine and the alternating current I_a which the machine takes from the power mains.

There is a fixed ratio between the voltages of the direct and alternating current sides of the machine. The voltage between the slip rings a and b is a maximum when x and y are in the neutral position and this must be the voltage between the brushes c and d of the direct-current side therefore E_d , the voltage of the direct-current end, is equal to the maximum volt-

age at the alternating-current end or to $\sqrt{2}E_a$ where E_a is the effective voltage at the alternating-current end.

It is impossible to change the voltage of the direct-current side of the machine without changing the alternating applied voltage. A change in the field excitation for example does not change the applied voltage, but it does change the phase angle of the current the converter takes from the line, see page 256, and a converter can be used for power factor correction in the same way as a synchronous motor, see page 257.

If it is desired to raise the voltage of the direct-current side of the machine then the alternating applied voltage must be raised.

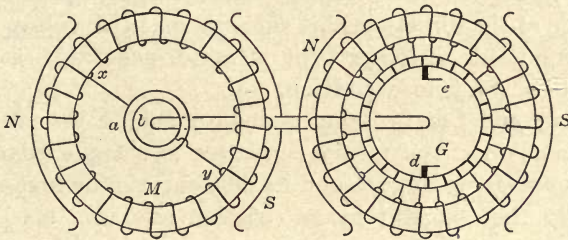

Synchronous Motor

Direct Current Generator

FIG. 381.

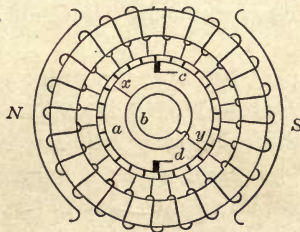

Rotary Converter

FIG. 382.—Diagrammatic representation of a rotary converter.

One method of doing this is to supply the rotary converter through a transformer which has taps on the secondary side by means of which the voltage may be raised or lowered. Another method is to insert a booster, generally on the alternating-current side of the machine. This booster consists of a small alternator, on the same shaft as the rotary converter, the voltage of which may be added to or subtracted from that of the alternating-current power mains.

351. Motor-Generator Sets and Rotary Converters.—The principal points of difference between the rotary converter, the

induction motor-generator set and the synchronous motor-generator set are as follows:

Starting.—On the alternating-current side, the rotary converter operates as a synchronous motor and must therefore be brought up to speed and synchronized, see page 258. The induction motor-generator set is self-starting.

Parallel Operation.—A synchronous motor and a rotary converter are liable to hunt, see page 258, although this trouble is practically eliminated by the use of dampers. Induction motors do not hunt.

Voltage Variation on the Direct-current Side.—In the case of the rotary, a booster or a boosting transformer is required to raise the voltage of the direct-current side whereas the voltage of the direct-current side of either type of motor-generator set can be controlled by the field excitation.

Efficiency and Cost.—Being a single machine instead of two separate machines, the rotary converter is cheaper than either type of motor-generator set and its efficiency is the highest since it has only the constant losses (friction and iron loss) of one machine.

Power Factor Control.—This is possible with the rotary converter and with the synchronous set but not with the induction motor-generator set.

For small sizes, up to 100 kw., the induction motor-generator set is generally preferred because it is easily started and because the voltage of the direct-current end can easily be regulated. For large sizes, 500 kw. and over, a synchronous machine is preferred because it can be used to control the power factor of the system; if the voltage regulation is not of great importance, as in railway work, the rotary converter is used, but if a wide variation of voltage is required from the direct-current side, a motor-generator set is generally preferred.

352. Polyphase Rotary Converter.—The only difference between the single-phase and the polyphase machine is that the former is tapped at two points, as shown in Fig. 382, whereas the latter has to be tapped as if the machine was a polyphase alternator of the revolving armature type, see page 241. A three-phase rotary is shown in Fig. 383; the armature is tapped at three points, 120 electrical degrees apart.

353. Split-pole Rotary Converter.—One method of changing the voltage of the direct-current side of a three-phase rotary con-

verter would be to change the total flux which passes between ab , Fig. 384, without changing the flux which passes between ac . This is accomplished by splitting each pole as shown diagrammatically in Fig. 384 and exciting each part separately. If then the excitation of the main pole M is unchanged, the flux threading ac will be unchanged, but the total flux threading ab may be increased or decreased by varying the excitation of R , and by this means the voltage of the direct-current side of the machine may be raised or lowered without any change being required in the alternating applied voltage.

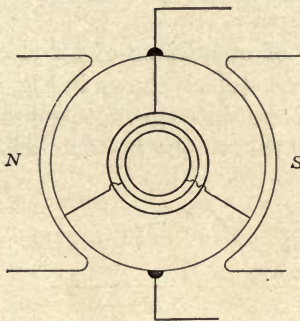

FIG. 383.—Three-phase rotary converter.

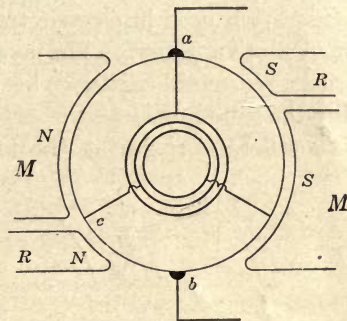

FIG. 384.—Split-pole rotary converter.

Another method of changing from alternating to direct current is described on page 357, the piece of apparatus by which the transformation is made is called the mercury vapor converter.

354. Frequency Changers.—To change from one frequency to another, a motor-generator set must be used which consists of a synchronous motor direct connected to an alternating-current generator. If 60 cycles have to be obtained from a 25-cycle line, then the number of poles must be in the ratio of 60 to 25, and the smallest possible number of poles would be 10 for the motor and 24 for the alternator; this set would run at 300 r.p.m., so that such frequency changers cannot readily be made for small outputs.

CHAPTER XL

ELECTRIC TRACTION

An electric car with a seating capacity for fifty persons is generally equipped with four motors each of 50 h.p. Such a powerful equipment is required to obtain the high speeds and high rates of acceleration used in electric traction.

355. Tractive Effort.—The cycle of operations of an electric car with a reasonable distance between stops is shown in Fig. 385. During the time interval *oa*, energy is put into the motors and the car is accelerating; during the interval *ab*, the motor circuit is

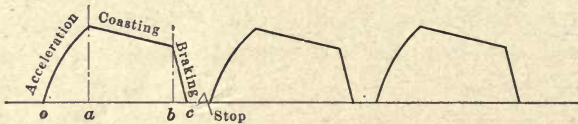

FIG. 385.—Cycle of operations of an electric car.

open and the car is coasting; during the interval *bc* the brakes are applied and the car gradually brought to rest.

If *W* is the weight of the train or car in tons (2000 lb.) and *a* is the acceleration in miles per hour per sec. then the tractive effort in lb., required for acceleration

$$\begin{aligned}
 &= \frac{\text{Weight in lb.}}{g} \times \text{acceleration in ft. per sec. per sec.} \\
 &= \frac{(W \times 2000)}{32.2} \times \frac{a \times 5280}{3600} \\
 &= 90 W \times a
 \end{aligned}$$

An additional accelerating tractive effort of about 10 per cent. is required to supply the rotational kinetic energy of the gears, motor armatures and other rotating parts so that the tractive effort required for acceleration = $100 W \times a = 100$ lb. per ton for each mile per hour per sec. of acceleration; an acceleration of 1.5 miles per hour per sec. may be used without discomfort to the passengers.

The tractive effort to overcome train friction (bearing, air and

rolling friction) is expressed in pounds per ton weight of train and is given by the empirical formula

$$f = \frac{50}{\sqrt{W}} + 0.03 V + 0.002 A \frac{V^2}{W} \left(1 + \frac{n-1}{10} \right)^1$$

where f is the tractive effort to overcome train friction in lb. per ton weight of train

W is the weight of the train in tons (2000 lb.)

V is the velocity of the train in miles per hour

A is the cross section of the car above the axle in sq. ft. and is generally about 120

n is the number of cars; the side friction of each additional car increases the air friction by 10 per cent.

When there is a curve in the track, an additional tractive effort of 0.7 lb. per ton for each degree of curvature is required due to the increased rolling friction; the number of degrees of curvature is equal to 5730 divided by the radius of the curve in feet.

When there is a grade an additional tractive effort of 20 lb. per ton is required for each 1 per cent. of grade. When the grade is 1 per cent. the car has to be lifted through 1/100 of the distance it travels and this is equivalent to lifting 1/100 of the weight, or 20 lb. per ton, through the whole distance travelled.

The maximum tractive effort that can be used without causing the driving wheels to slip is about 22 per cent. of the weight on these wheels, since maximum tractive effort = $\mu \times$ weight on the driving wheels, where μ , called the coefficient of adhesion, has the following values:

for a clean dry rail	= 0.28
a greasy moist rail	= 0.1 or when rail sanded = 0.25
a dry snow covered rail	= 0.11 or when rail sanded = 0.15

356. Speed Time Curve.—The characteristics of a traction load can best be shown by the working out of an actual example.

A 30-ton suburban car is equipped with four 50-h.p. motors having the characteristics shown in Fig. 386. The acceleration has to be 1.25 and the deceleration 1.5 miles per hour per sec.; the road is level and without curves and the distance between stops 0.75 miles, the time of the stop 9 sec. and the

¹ Electric Traction by A. H. Armstrong, Standard Handbook for Electrical Engineers.

schedule speed 21 miles per hour. It is required to draw the speed time curve.

$$f = \frac{50}{\sqrt{W}} + 0.03V + 0.002 \times 120 \times \frac{V^2}{W} \left(1 + \frac{n-1}{10}\right)$$

$$= 9 + 0.3 + 0.8 = 10.1 \text{ lb. per ton at 10 miles per hour}$$

$$= 9 + 0.6 + 3.2 = 12.8 \text{ lb. per ton at 20 miles per hour}$$

$$= 9 + 0.9 + 7.2 = 17.1 \text{ lb. per ton at 30 miles per hour}$$

Now the effective tractive effort for an acceleration of 1.25 miles per hr. per sec.

$$= 125 \text{ lb. per ton.}$$

The train friction during acceleration will be approximately

$$= 11 \text{ lb. per ton.}$$

Therefore the total tractive effort required

$$= 136 \text{ lb. per ton} = 136 \times \frac{30}{4} = 1020 \text{ lb. per motor.}$$

Corresponding to this value on Fig. 386, the speed with 550 volts = 19 miles per hour and the current per motor = 100 amp.

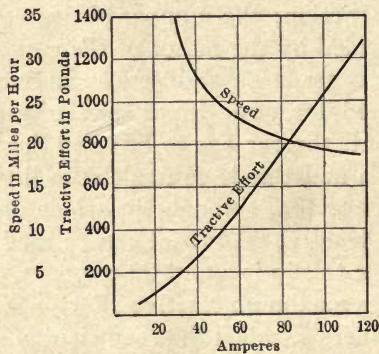

FIG. 386.—Characteristics of a 50-horse-power, 550-volt direct-current motor, the tractive effort and the speed being measured at the rim of the driving wheels of the car.

The motor is so controlled that the current remains constant at 100 amp. per motor and the acceleration has a constant value of 1.25 miles per hour per sec. until the speed has become 19 miles per hour; the starting resistance has then all been cut out and normal voltage is applied to the motors.

The time taken to attain this speed = $\text{vel./accel.} = 19/1.25 = 15.2 \text{ sec.}$
 and the distance covered during this time = $\frac{19 \times 5280}{2} \times \frac{15.2}{3600} = 211 \text{ ft.}$
 from these figures the points a , a_1 and a_2 are plotted in Fig. 387.

The motor, running on normal voltage, will now speed up, and the current will decrease. Let the current decrease to 60 amp. then:

The corresponding tractive effort = 500 lb. per motor and the speed = 23 miles per hour, Fig. 386.

The average tractive effort while the current is decreasing = $\frac{1020 + 500}{2}$

= 760 lb. per motor = $760 \times 4/30 = 101$ lb. per ton

The train friction at 21 miles per hour = 13 lb. per ton

The tractive effort available for acceleration = 88 lb. per ton

The average acceleration = $88/100 = 0.88$ mile per hour per sec.

The time taken for the speed to attain 23 miles per hour = $\frac{23 - 19}{0.88} = 4.6$ sec.

The distance covered during this time = $\frac{23 + 19}{2} \times \frac{5280}{3600} \times 4.6 = 142$ ft.

The distance covered from the start = $211 + 142 = 353$ ft.

From these figures the points b , b_1 , and b_2 , are plotted in Fig. 387; points c for a current of 40 amp. and d for 30 amp. are determined in a similar way.

Now the schedule speed is 21 miles per hour.

The distance covered is 0.75 mile.

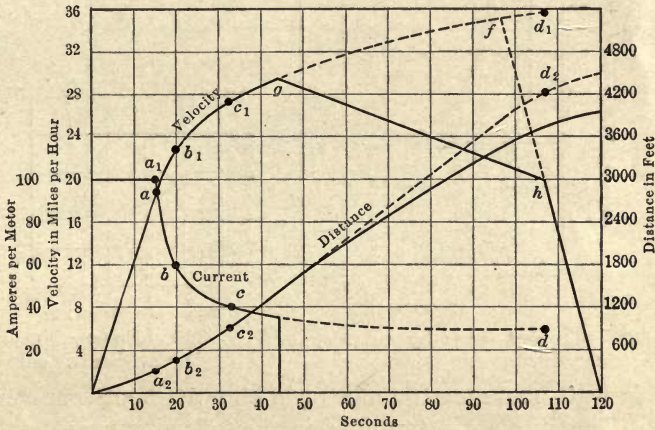

FIG. 387.—Speed-time curve of an electric car.

The time per cycle = $0.75/21 = 0.0356$ hour = 129 sec. of which 120 sec. is the running time and 9 sec. the time of the stop.

In order to bring the car to rest in 120 sec. from the start the brakes must be applied at some point f such that the deceleration will be 1.5 miles per hour per sec.

If the distance curve be now completed it will be found that the car has travelled a distance of 4500 ft. In order that this distance be 0.75 mile, power must be taken off the car at some point g and the car allowed to coast thereby reducing the average speed of the run. During coasting, the speed will fall off according to the curve gh . The slope of this line is determined as follows: the average velocity during coasting is 25 miles per hour and the corresponding retarding force due to train friction is 15 lb. per ton which will cause a deceleration of 0.15 mile per hour per sec. or a decrease in speed of 1.5 miles every 10 sec.

357. Energy Required by a Car.—The series parallel method of control, page 126, is used for railway motors so that between *a* and *b*, Fig. 388, the current taken from the line is twice the current per motor while between *b* and *c* four times the current per motor is taken from the line.

The average current per cycle = 225 amp.

The average power per cycle = $\frac{225 \times 550}{1000} = 123 \text{ kw.}$

The energy per cycle = $\frac{123,000 \times 44}{3600} = 1500 \text{ watt-hr.}$

It is convenient to express the energy required by a car or

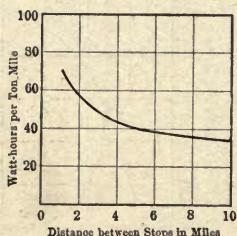
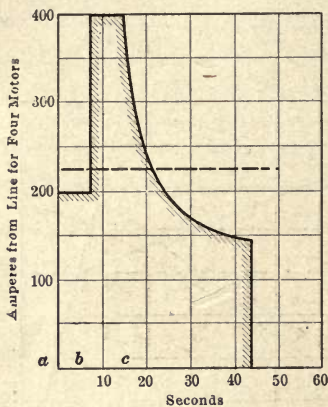

FIG. 388.—Current taken by an electric car during one cycle.

FIG. 389.—Energy consumed by an electric car.

train in watt-hours per ton mile or in kilowatt-hours per car mile. These quantities are determined in the following way:

The energy per cycle = 1500 watt-hours

The distance travelled per cycle = 0.75 mile

The weight of the car = 30 tons

The watt-hours per ton mile = $\frac{1500}{0.75 \times 30} = 67$

The kilowatt-hours per car mile = $\frac{1500}{1000} \times \frac{1}{0.75} = 2.0.$

These two quantities decrease as the distance between stops increases, as shown in Fig. 389, because then the energy required to accelerate the car becomes a smaller portion of the total energy per cycle. In the extreme case of city service, the coasting period is generally eliminated, the distance between stops being so short that only acceleration and braking are required.

From curves such as those in Fig. 389, the power house capacity

may be determined once the number of cars and their schedule has been fixed.

358. Characteristics Desired in Railway Motors.—The series motor is particularly suited for traction service, see page 103, because it develops the large starting torque required with the minimum current, see page 102. In addition, it takes light loads at a high speed and heavy loads at a slow speed, slows down on an up grade and speeds up on a down grade, it therefore maintains the load on the power house more uniform than if constant speed motors such as the direct-current shunt motor or the alternating-current induction motor were used.

The alternating-current series motor, see page 310, has the same characteristics as the direct-current series motor but is more

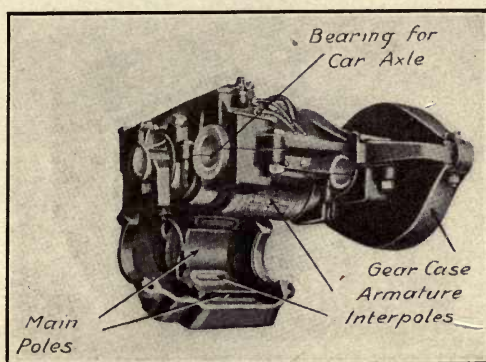

FIG. 390.—Direct-current street railway motor.

expensive, has a lower efficiency and does not commutate so well. The method of control is simpler however, the low voltage required for starting being obtained by means of an autotransformer instead of by the use of resistance and the series-parallel connection. These motors can run on direct as well as on alternating current circuits.

For one particular kind of service the polyphase induction motor is specially suited, even although it is a constant speed motor, and that is for mountain grade work where the grades are long and fairly uniform. When the car is on the down grade, the motors tend to speed up and run above synchronous speed, and, under these conditions they become induction generators and supply power back to the line. With a speed of 4 per cent. above synchronous speed, the machine will deliver its full-load rating

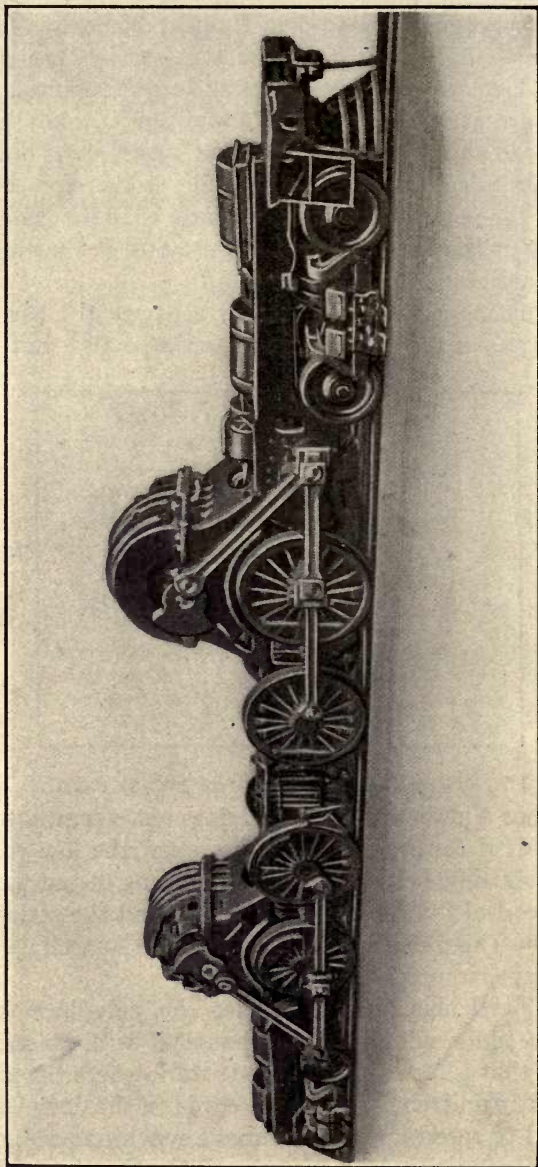

FIG. 391.—Electric locomotive driven through side rods.

to the line, so that braking with brake shoes is not necessary and the danger of trouble on a long grade due to overheating of brake shoes is practically eliminated.

359. Motor Construction.—To keep down the size of the motors they must run at a high speed, see page 101, so that gears are generally necessary. The standard construction for urban and interurban cars is shown in Fig. 390.

Motors which are placed between the driving wheels, as are all street car motors, are restricted in size. This restriction is most keenly felt in the design of large horse-power slow-speed motors for electric locomotives for freight service. One method of providing increased space for the motors is shown in Fig. 391 where two motors each of 2000 h.p. are mounted in the car and are connected to the driving wheels through side rods.

360. Distribution to the Cars.—The three standard railway systems are shown diagrammatically in Figs. 392, 393 and 394.¹

With the single-phase system the trolley voltage may be as high as 11,000 volts and in order to render high speed collection reliable with long spans the catenary construction is used, the trolley wire being carried from a steel messenger cable, the latter having a sag while the former lies parallel with the rails.

Because of commutation troubles the standard direct-current voltage is not higher than 600 volts although there are lines in operation at 1200 volts and a few experimental lines at 2400 volts. Large currents are therefore necessary for electric trains and to carry this current a third rail insulated from the ground is used instead of the trolley wire if the trains run on a private right of way. For city service the familiar trolley is used and the trolley system is supplied by feeders from substations.

The return circuit is through the rails in each case. This circuit is made as highly conducting as possible by bridging all the rail joints with flexible pieces of copper called bonds which are electrically welded to the side of the rail.

361. Alternating- and Direct-current Traction.—The single-phase alternating current system has the advantage that voltages as high as 11,000 volts may be used on the trolley so that the current in the trolley wire is small and power may be transmitted for long distances before the voltage drop becomes too large, the substations therefore are few in number and contain merely

¹ Taken from a paper by George Westinghouse, in the Trans. of American Soc. of Mech. Eng., July 1910.

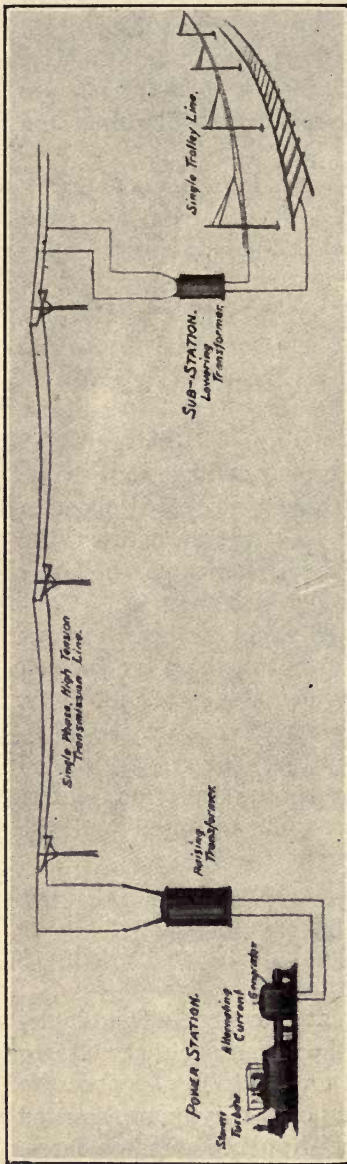

FIG. 392.—Single-phase system.

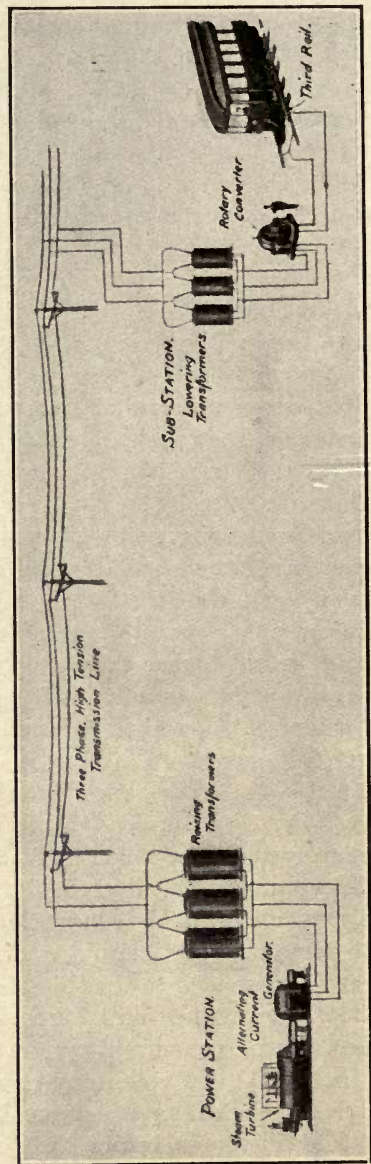

FIG. 393.—Direct-current system.

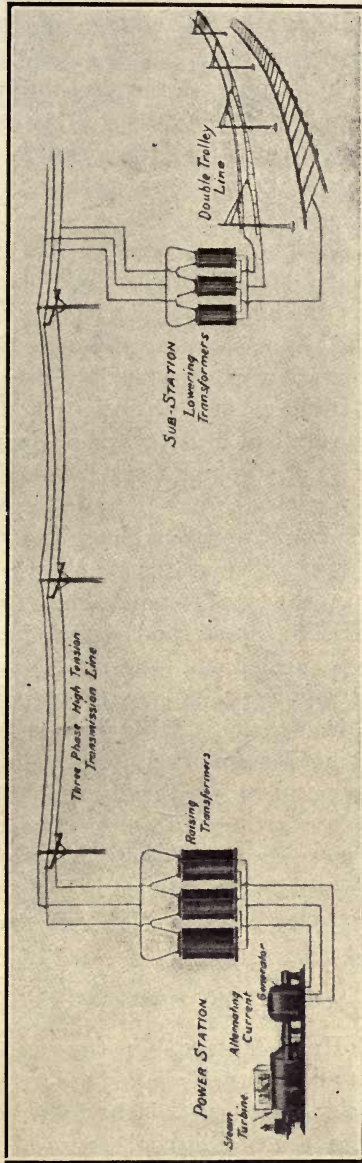

Fig. 394.—Three-phase system.

the necessary step-down transformers. For the direct-current system, on the other hand, at 600 volts, substations must be closer together to maintain the trolley voltage and these substations contain rotary converters as well as step-down transformers.

The principal disadvantages of the alternating-current system are that the motors are heavier than direct-current motors of the same horse-power, while the alternating magnetic flux linking the trolley causes interference with adjoining telephone systems.

362. Motor Car Trains.—A number of cars each with its own motors and controller may be joined together to form a train which, by means of the multiple unit system of control, see page 133, can be controlled by a single operator at the head of the train. This system of operation is very flexible because cars can be added to suit the traffic while trains can readily be split up at junctions or single cars can be attached or dropped as required without the necessity of stopping the whole train.

The acceleration can be rapid because all the weight is on the drivers and a large draw bar pull can be obtained. Heavier trains can also be run at higher speeds than by locomotives, while the wear and tear on the track is reduced because the weight is so well distributed. Such trains can be run in either direction without having to be turned end for end.

363. Electric Locomotives.—When the cars of a steam road have to be hauled into the city, through tunnels, or on mountain grades, electric locomotives are often used. Their capacity is not limited by grate area and boiler capacity so that they can develop very large torques for starting and accelerating and can generally give 50 per cent. more draw bar pull than a steam locomotive of the same weight. The torque also is uniform, such locomotives can therefore give high acceleration and high schedule speeds.

ELECTRIC HOISTING

364. Crane and Hoist Motors.—In the case of cranes, where the load is visible at all times and where the starting and accelerating of the load is a large part of the total hoisting cycle, the direct current series motor is used because of its good starting characteristics. Where only alternating current is available, the wound rotor polyphase induction motor is generally used, but it is not such a satisfactory machine, see page 298.

Motors for large cranes, such as those used in rolling mills, take large currents and are generally controlled by magnetic switch controllers.

When the load has to be raised a considerable distance, as in the case of mine hoisting, the load is accelerated for only a small portion of the total cycle and is run thereafter at a constant speed not greater than that fixed by law. For such service the direct-current compound motor is suitable because its speed cannot exceed a safe maximum value. Where only alternating current is available, the polyphase wound rotor induction motor is used.

365. Braking.—The brakes used on cranes and hoisting machines must be so constructed that they will set if there is any interruption in the current supply. Such a brake is shown in Fig. 395. When power is switched on to start the hoisting motor, the solenoid lifts the lever *L* and releases the brake, but as soon as current ceases to flow, the weight *W* sets the brake.

When a light load is being lowered, power must be applied to drive it down. When the load is heavy, it may be

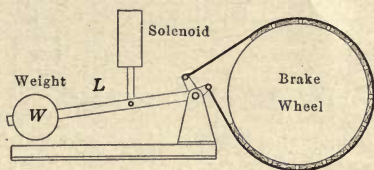

FIG. 395.—Brake for hoists and cranes.

allowed to overhaul the motor, the speed being kept within reasonable limits by means of the brake. This causes jerky operation, and excessive wear of the brake, and, for coal and ore unloaders and other such hoists doing fast hoisting service, mechanical braking is not very satisfactory and dynamic braking is now used.

The hoisting motors for such hoists are direct-current compound wound and are connected as in Fig. 396 during the hoisting period. When being lowered, the empty bucket is allowed to overhaul the motor, which is connected as shown in Fig. 397, the shunt coils being separately excited while the armature is short circuited through an adjustable resistance *R*. The machine then acts as a generator driven by the descending load and sends a current *I* through the resistance *R*. As the machine speeds up, the current *I* increases until the retarding torque due to the current *I* becomes equal to the effective torque driving the armature.

To raise the lowering speed, the resistance *R* must be increased. This reduces the current *I* and the braking torque temporarily, and the speed increases until the greater e.m.f. generated in the

armature is again able to send the necessary current I through the higher resistance. By varying the resistance R , the lowering speed may be varied from almost zero to any desired value. To stop the load, a mechanical brake must be applied, since dynamic braking can only take place while the armature is moving.

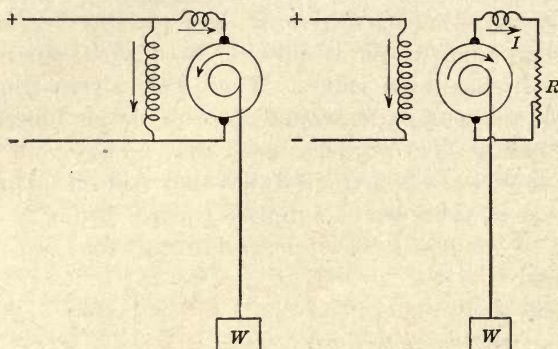

FIG. 396.—Hoisting period.

FIG. 397.—Lowering period, with dynamic braking.

FIGS. 396 and 397.—Connections of a compound-wound direct-current hoist motor.

Dynamic braking is also applied to crane motors. During hoisting, the motor is connected as shown in Fig. 398. On the first step of the controller about two-thirds of full-load current flows through the circuit, and this is sufficient to release the brake and start the average load.

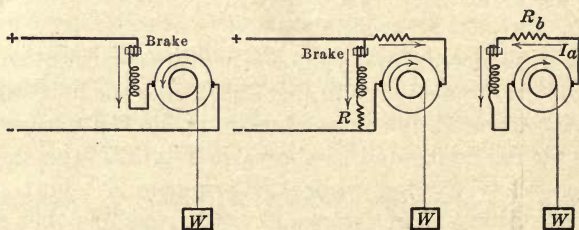

FIG. 398.—Hoisting. FIG. 399.—Lowering. FIG. 400.—Dynamic braking.

FIGS. 398 to 400.—Connection of a series-wound direct-current crane motor.

When lowering, the machine is changed over to a shunt machine as shown in Fig. 399 and a resistance R is inserted to limit the flow of current in the field coil circuit to two-thirds of full-load current, which is sufficient to release the brake. The direction of

the field current is the same as during hoisting, but the armature terminals are reversed so that the armature current is reversed and the motor drives the load down. If the load is heavy enough to overhaul the motor, then the motor speeds up and its back e.m.f. increases, until finally the machine runs as a generator and acts as a brake. The current I_a is now reversed and the machine supplies its own exciting current, so that it may be disconnected from the line as shown in Fig. 400 and the braking speed adjusted by means of the rheostat R_b .

366. Flywheel Motor Generator Sets for Mine Hoisting.—The load on the motor of a hoist is extremely variable, as shown by curve A, Fig. 401, and, when the motor has an output of 500 h.p. or more as in the case of motors for mine hoists, such a load is not a very desirable one for a power company, and a

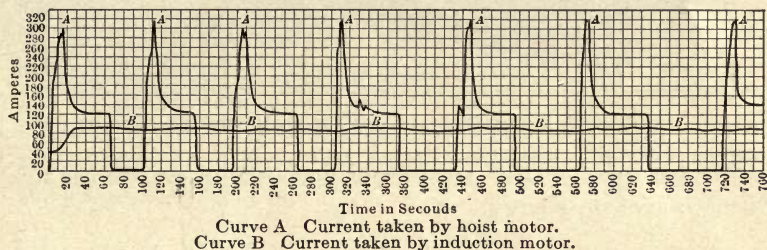

FIG. 401.—Characteristics of a hoisting load when a fly-wheel motor-generator set is used.

cheaper rate for power can generally be obtained if the load is more uniform.

To obtain this result and at the same time to reduce the large losses in the starting rheostat, the Ward Leonard system, see page 110, is used. The high speed motor generator set consists of a wound rotor induction motor which takes power from the transmission line, and a direct-current generator which supplies power to the hoisting motor, while a heavy flywheel is mounted on the same shaft as shown in Figs. 402 and 403.

The excitation of the hoisting motor is kept constant by means of the exciter E , while the speed of the motor is controlled by the resistance r in the generator field circuit, by means of which the voltage E_t applied to the motor terminals may be varied.

As the load on the hoist motor increases, the current in the induction motor leads tends to increase in the same ratio, but a slight increase in the current I causes the plunger p of the sole-

noid S to raise the plates of the water rheostat W thereby increasing the resistance in the rotor circuit, so that the rotor current and torque are maintained constant. This torque is not sufficient

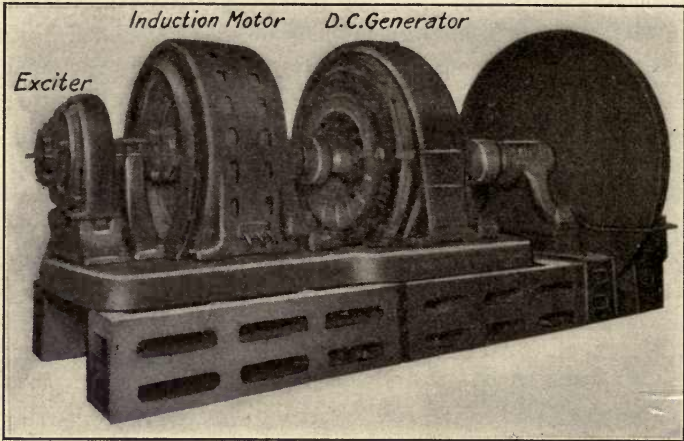

FIG. 402.—Flywheel motor-generator set for the operation of mine hoists.

for the load, so that the speed drops and thereby causes the fly-wheel to give up energy.

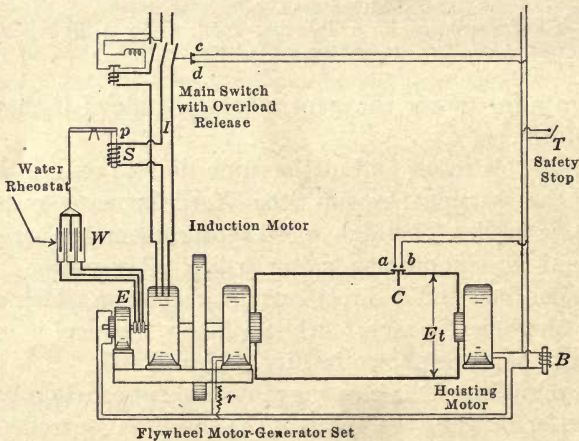

FIG. 403.—Connections for a hoist motor supplied by a fly-wheel motor-generator set.

If the load on the hoist motor now decreases, the current I tends to decrease, but a slight decrease in this current causes the pull of solenoid S to decrease and the plates of the water rheostat

to drop, thereby decreasing the resistance in the rotor circuit, so that the rotor current and the rotor torque are maintained. This torque is greater than necessary for the load and so accelerates the flywheel.

By means of such a slip regulator, the power taken from the line is maintained approximately constant, as shown in curve *B*, Fig. 401.

367. Safety Devices.—The safety brake is of the type shown in Fig. 395 and will set and hold the load as soon as current ceases to flow in the solenoid *B*.

If for example the field circuit of the hoisting motor were to open, the current in the solenoid *B* would be interrupted and the brake would set.

If the cage overtravels, it closes the switch *T* in the hatchway and this shunts the current from the solenoid *B* and allows the brake to set. The resulting overload then opens the circuit breaker *C*.

The solenoid *B* is also shunted when, due to an excessive overload, the circuit breaker *C* opens and closes the contacts *ab*. A similar pair of contacts *cd* ensure that the brake shall be set when the main switch is open.

CHAPTER XLI

TRANSMISSION AND DISTRIBUTION

368. Direct-current Stations.—When direct current is used, the voltage can be transformed up and down only by means of motor generator sets and, since these are expensive and require supervision, they are seldom used, so that the connected load of motors and lamps must operate at the power house voltage.

The 110-volt lamp is practically standard because it has a stronger filament than have lamps of higher voltage. The use of such a low voltage necessitates the use of conductors of large cross section to carry the current, and higher voltages are desirable.

If 50 kw. has to be transmitted a distance of 100 yd. with a drop in voltage not exceeding 2.5 per cent., find the necessary cross section of the conductor if the voltage is 110 volts and also if it is 220 volts. The resistance of copper is taken as 11 ohms per cir. mil foot.

	At 110 volts	At 220 volts
Current in the line . . .	$= \frac{50 \times 1000}{110} = 455 \text{ amp.}$	$= \frac{50 \times 1000}{220} = 227 \text{ amp.}$
Voltage drop in the line.	$= 2.5\% \text{ of } 110 = 2.75 \text{ volts}$	$= 2.5\% \text{ of } 220 = 5.5 \text{ volts}$
Resistance of the line..	$= \frac{2.75}{455} = 0.006 \text{ ohms}$	$= \frac{5.5}{227} = 0.024 \text{ ohms}$
Resistance of 200 yd. of wire.	$= \frac{11 \times 200 \times 3}{\text{cir. mils}} = 0.006$	$= \frac{11 \times 200 \times 3}{\text{cir. mils}} = 0.024$
Cross section of wire in cir. mils.	$= 1,100,000$	$= 275,000$

The cross section of the wire is inversely proportional to the square of the voltage for the same loss in the line.

If the three-wire system of distribution is used then 110 volt lamps may be operated from 220 volt mains as shown in Fig. 376, page 316. The neutral wire may be small in cross section if the load is nearly balanced under all conditions of loading.

Where there is only a small lighting load, or where the lights

are supplied from special mains, then a voltage of 550 may be used for the motors. Voltages greater than 550 are dangerous; even 110 volts may prove fatal to a person who happens to make unusually good contact with the mains.

369. Alternating-current Stations.—Where power has to be transmitted a long distance or has to be distributed over a wide area, the alternating-current system is preferred because the voltage can be transformed up and down by means of transformers. These require no supervision and may be installed in the open, on poles or in manholes.

A typical high-voltage transmission system is shown in Fig. 404. The power station contains the generators and step-up

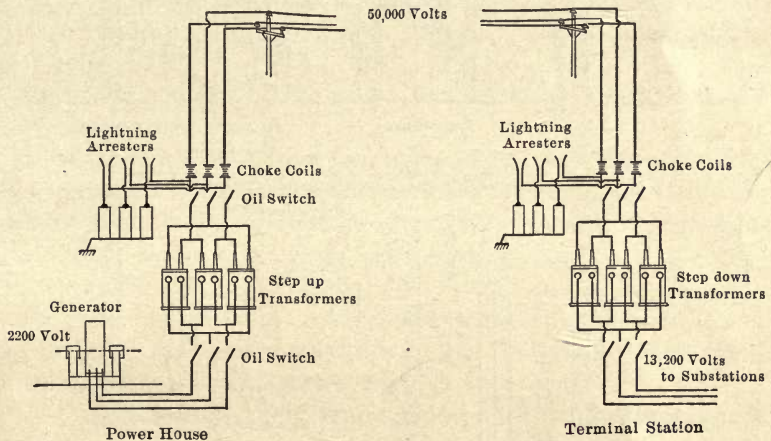

FIG. 404.—Diagrammatic representation of a high voltage transmission system.

transformers while the step-down transformers are placed in a terminal station. The load is carried by several units operating in parallel so that one machine may be shut down for repair without affecting the total load.

From the terminal station, power is transmitted to a number of substations which are conveniently located with respect to the load. In the case of a transformer substation, the equipment consists of the necessary step-down transformers to reduce the voltage to 2200 volts at which it is supplied to the feeders. Each feeder is generally controlled by a feeder regulator, see page 281, by means of which its voltage may be adjusted. These feeders

supply transformers which are placed on poles, or underground in manholes, and step the voltage down to 110 volts for the consumer.

When it is necessary to transform to direct current as for example to supply power to a large machine shop, the substation equipment is as shown in Fig. 405. Power enters the station over the three bare wires *a*, *b*, and *c* which are carried through porcelain

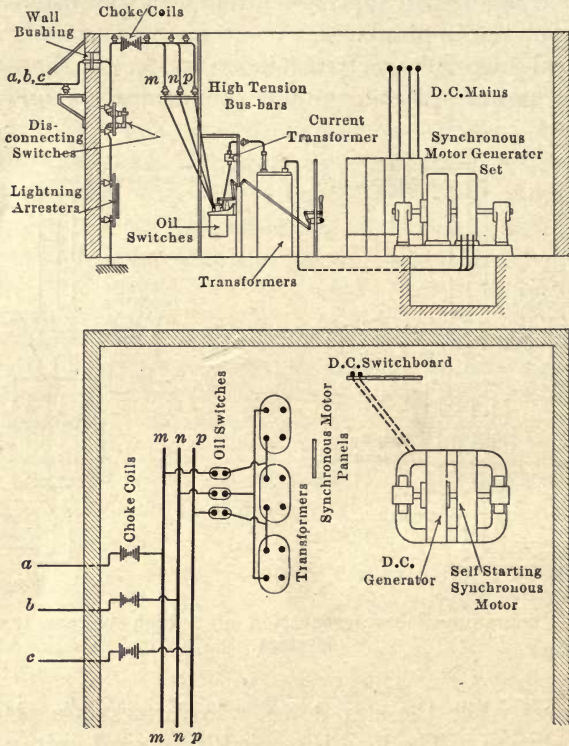

FIG. 405.—Connections of an A.-C. to D.-C. motor-generator sub-station.

wall bushings and are connected to the high-tension bus bars *m*, *n* and *p*. Power to operate the synchronous motor is taken from these bus bars through a delta-connected bank of transformers by which the voltage is reduced to 2200 volts, while half voltage taps are also supplied so that the self-starting motor may be started at half voltage; the double-throw switch for this purpose is not shown.

370. The voltages used in practice are:*Direct Current:*

110 volts for lighting, generally obtained from a 220-volt three-wire system.

110, 220 and 550 volts for motors.

600 volts for street railway systems.

1200 volts for interurban systems.

2400 volts for trunk-line electrification.

Alternating Current:

110 volts single phase for lighting and for small motors.

110, 220, 440 and 550 volts for polyphase motors up to 50 h.p.

440, 550 and 2200 volts for polyphase motors greater than 50 h.p.

13,200 volts is the highest voltage generated by alternators; low-voltage alternators with step-up transformers are more reliable.

100 volts per mile of line with a maximum of 110,000 volts for power transmission.

The tendency is to use a frequency of 60 cycles for power and lighting work as it gives a better choice of speeds for induction motors than does 25 cycles, see page 297. For single-phase railway work, however, 25 cycles are necessary because of the difficulty in constructing motors that will commutate satisfactorily at a higher frequency. In the case of cement mills and other such places where most of the induction motors are slow-speed machines, 25 cycles may be used with advantage.

371. Comparison between single-phase and three-phase transmission.

10,000 kw. at 80 per cent. power factor has to be delivered at the end of a single-phase 25-mile line at 50,000 volts and 60 cycles. The size of wire is No. 000 and the wires are spaced 72 in. apart. Find the voltage at the generating station and also the power loss in the line.

the resistance of this wire = 0.326 ohms per mile, page 216.

the reactance at 60 cycles = 0.742 ohms per mile, page 216.

the current in the line = $\frac{10,000 \times 1000}{0.8 \times 50,000} = 250$ amp.

the resistance drop in 50 miles of wire = IR
 $= 250 \times 0.326 \times 50$
 $= 4075$ volts

the reactance drop in 50 miles of wire = IX
 $= 250 \times 0.742 \times 50$
 $= 9250$ volts.

the voltage of the generating station = E_0 , Fig. 406.

the power loss in the line

$$\begin{aligned}
 &= \sqrt{(E_t \cos \alpha + IR)^2 + (E_t \sin \alpha + IX)^2} \\
 &= \sqrt{(40,000 + 4075)^2 + (30,000 + 9250)^2} \\
 &= 59,000 \text{ volts} \\
 &= I^2 R \\
 &= 250^2 \times 0.326 \times 50 \\
 &= 1020 \text{ kw.} \\
 &= 10.2 \text{ per cent. of the output}
 \end{aligned}$$

15,000 kw. at 80 per cent. power factor has to be delivered at the end of a three-phase 25-mile line at 50,000 volts and 60 cycles. The size of wire

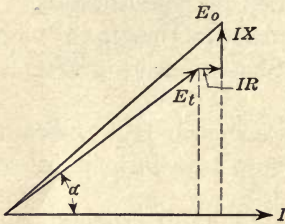

FIG. 406.

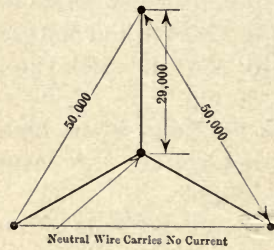

FIG. 407.

is No. 000 and the wires are spaced 72 in. apart. Find the voltage in the generating station and also the power loss in the line.

$$\begin{aligned}
 \text{the resistance of the wire} &= 0.326 \text{ ohms per mile.} \\
 \text{the reactance at 60 cycles} &= 0.742 \text{ ohms per mile.} \\
 \text{the current in the line} &= \frac{15,000 \times 1000}{0.8 \times 1.73 \times 50,000} = 217 \text{ amp.}
 \end{aligned}$$

The problem is best solved by considering each line separately as shown in Fig. 407 then

$$\begin{aligned}
 E_t, \text{ the line voltage to neutral} &= 50,000/1.73 = 29,000 \text{ volts} \\
 \text{the resistance drop in 25 miles of wire} &= IR \\
 &= 217 \times 0.326 \times 25 \\
 &= 1770 \text{ volts} \\
 \text{the reactance drop in 25 miles of wire} &= IX \\
 &= 217 \times 0.742 \times 25 \\
 &= 4020 \text{ volts} \\
 \text{the line voltage to neutral at the generating station}
 \end{aligned}$$

$$\begin{aligned}
 &= \sqrt{(29,000 \times 0.8 + 1770)^2 + (29,000 \times 0.6 + 4020)^2} \\
 &= 32,950 \text{ volts}
 \end{aligned}$$

$$\begin{aligned}
 \text{the voltage between lines} &= 32,950 \times 1.73 \\
 &= 57,000 \text{ volts} \\
 \text{the power loss in the line} &= 3 \times 217^2 \times 0.326 \times 25 \\
 &= 1150 \text{ kw.} \\
 &= 7.6 \text{ per cent. of the output.}
 \end{aligned}$$

372. Lightning arresters are used to protect electrical equipment from lightning discharges and abnormally high voltages of all kinds.

The current due to a lightning discharge has a high frequency and will not pass readily through a reactance, so that, if, as in Fig. 408, a resistance path R is provided to ground with an air gap g long enough to prevent the flow of current under normal conditions, and a reactance or choke coil C is placed between the line and the equipment to be protected, then a lightning discharge will be held up by the choke coil and will jump across the air gap to ground.

Once an arc is started across the gap, however, the line current will follow through the path $abcd$, and provision must be made in the arrester to prevent this current from passing. The current may be limited by inserting a resistance R in series with the gap, while, if the electrodes of the air gap are made of non-arcing metal,

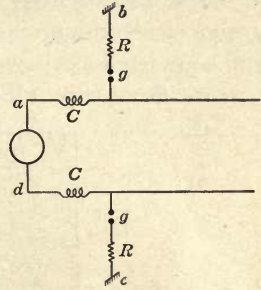

FIG. 408.—Connection of lightning arresters.

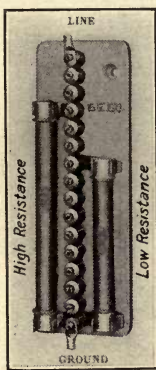

FIG. 409.—3000 volt multigap arrester for station installation.

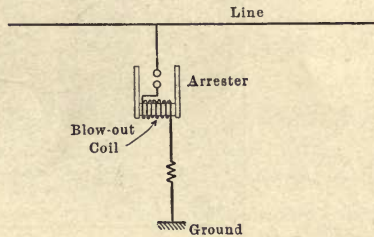

FIG. 410.—Lightning arrester for direct-current circuits.

that is metal such as zinc which has a low boiling point, then, on an alternating-current line, the arc will not be maintained but will stop as the alternating current passes through zero. A single gap of non-arcing metal will protect a 300-volt line, for higher voltages, several gaps are placed in series as in the 3000-volt

arrester shown in Fig. 409 which is really equivalent to three arresters one with 3 gaps and a high resistance in series, another with 6 gaps and a lower resistance in series, and the third with 15 gaps in series.

It is not so easy to rupture a direct current and, even when non-arcing electrodes are used, it is necessary also to supply a blow-out coil connected as shown in Fig. 410, which is excited when a power current flows through the arrester.

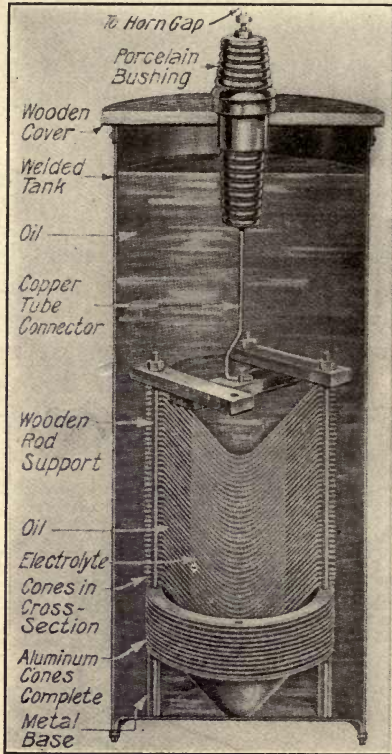

FIG. 411.—Aluminium arrester.

For the protection of long-distance high-voltage transmission lines the aluminium arrester is generally used. An aluminium cell consisting of two aluminium plates on which a film of hydroxide has been formed, when immersed in a suitable electrolyte, will allow only a very small current to flow, until the voltage reaches a critical value. At a higher voltage, the current that can flow is very large but the high resistance is reestablished as

soon as the voltage is reduced below the critical value. Such a cell can therefore act as a safety valve and aluminium arresters are made up in the form shown in Fig. 411, about 300 volts per pair of plates being allowed.

Even with 300 volts between plates, a small current flows, to prevent which, the arrester is connected to the line through a horn gap as shown in Fig. 404. When the arrester is disconnected from the line, however, the hydroxide film dissolves, so that the arrester must be charged daily by being connected to the line by the closing of the horn gap for a few seconds.

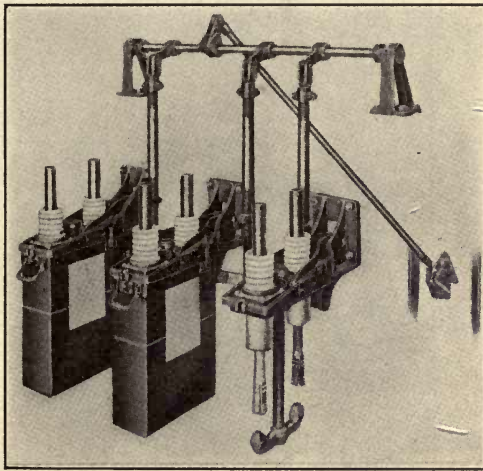

Fig. 412.—Hand-operated, triple-pole oil switch.

373. Switches.—Oil switches such as that shown in Fig. 412 are used to rupture the current in high-voltage lines. These switches are generally kept at a distance from the operator and are opened and closed through a system of levers, or may be of the remote control type operated by means of a solenoid or by a small motor. In all cases the switch is closed against the tension of a spring and is held closed by means of a latch. This latch may be released by an overload relay, so as to allow the switch to open when the current becomes excessive.

To localize trouble, important switches are generally mounted as shown in Fig. 413 with each pole in a separate brick or concrete compartment.

Disconnecting switches such as that shown in Fig. 405 are not

intended to open while current is flowing but are used to disconnect apparatus once the circuit has been opened by an oil switch. Such disconnecting switches are opened and closed by a long stick with a hook attached to the end.

374. Overhead Line Construction.—For voltages up to 50,000, wooden poles with pin insulators are used to support the line. For higher voltages, pin insulators become very large and the

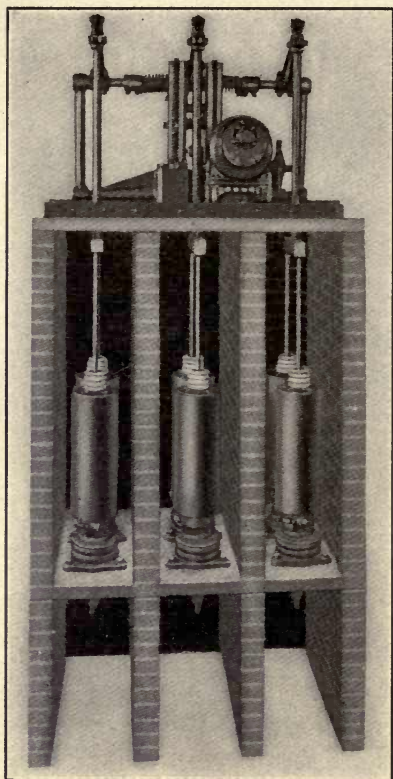

FIG. 413.—Motor-operated, triple-pole oil switch.

stresses on the pin become excessive, so that the suspension type of insulator has to be used and these are generally suspended from steel towers as shown in Fig. 415.

To protect the line from lightning, it is usual to run a steel wire parallel to the power wires, and to ground this wire at every tower. Lightning will generally strike this ground wire and pass to the

ground without doing injury, rather than strike the power wires and then pass to ground through the insulators.

375. Underground Construction.—To carry current underground, stranded copper cable is used. The copper is insulated with paper which is then impregnated with a compound such as

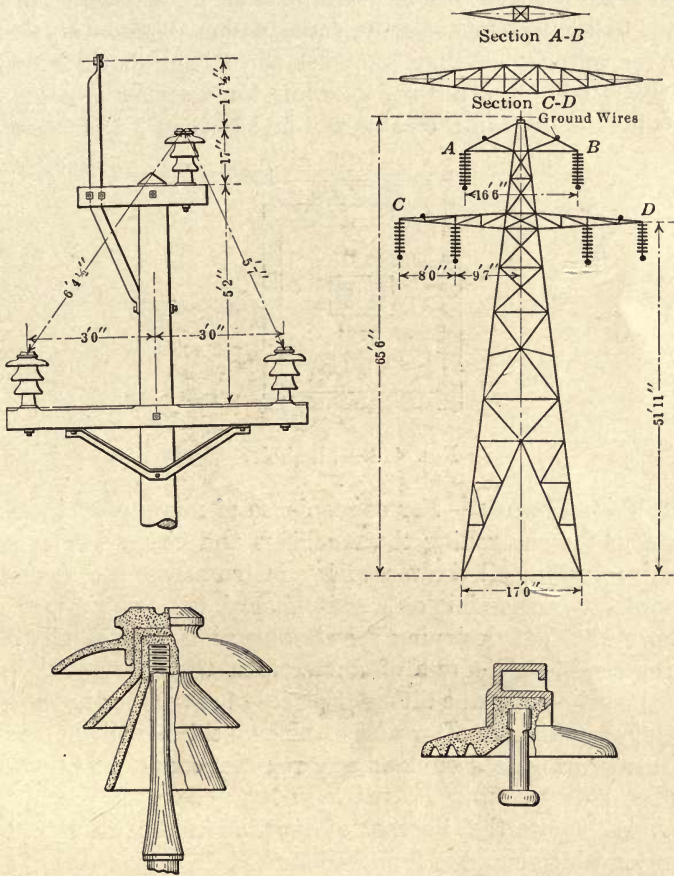

FIG. 414.—Wooden pole with pin insulators, and ground wire at top.

FIG. 415.—Steel tower with suspension insulators.

resin oil after which the cable is sheathed with lead which keeps out moisture and at the same time protects the cable against mechanical injury. The cable has to be flexible enough to bend round corners because it has to be drawn into tile ducts through manholes such as that shown in Fig. 416, which manholes are restricted in size.

The necessary cross section of copper is generally fixed by the permissible voltage drop in the case of low-voltage cables, but is always fixed by heating in high-voltage cables. A current density of 1000 amp. per sq. in. of copper section can seldom be exceeded, and this requires 8.7 volts per 500 ft., which is 2.5 per cent. of 350 volts, so that, if the voltage drop is limited to 2.5 per cent. and the transmission distance is 1000 ft., then, for voltages less than 350 volts, the current density must be less than 1000 amp. per sq. in. while for voltages greater than 350 volts, the drop in the cable will be less than 2.5 per cent.

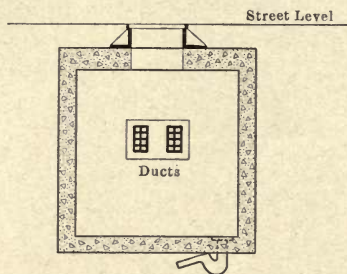

FIG. 416.—Manhole.

376. Switchboards.—For convenience of manipulation, all the apparatus for controlling the machines and circuits in a power station, as well as all the measuring instruments, are assembled as compactly as possible on a switchboard.

The method of designing a switchboard is first of all to lay out the complete diagram of connections, then design the front of the board placing the different pieces of apparatus in the most convenient positions, after which the connections on the back of the board can be laid out and any rearrangement necessary can then be made.

Fig. 417 shows the diagram of connections for a single shunt generator which supplies four feeders.

Fig. 418 shows the front of the board.

Fig. 419 shows the connections as they would appear if the slate front of the board was removed. This diagram is lettered similarly to Fig. 417.

In larger stations it is usual to provide a separate panel on the switchboard for each machine and also for each feeder.

Fig. 420 shows a three panel switchboard for a three phase alternator, a three phase feeder and an exciter.

The exciter panel is equipped with:

1 ammeter A_1 .

1 handwheel for the exciter rheostat R_1 .

1 switch S , with a fuse which is on the back of the panel.

2 switches S_1 and S_2 for the station lighting and other auxiliary circuits.

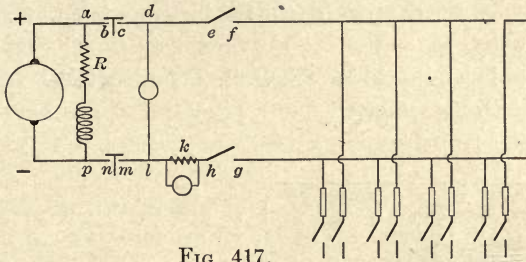

FIG. 417.

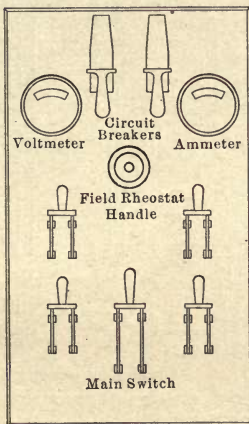

FIG. 418.

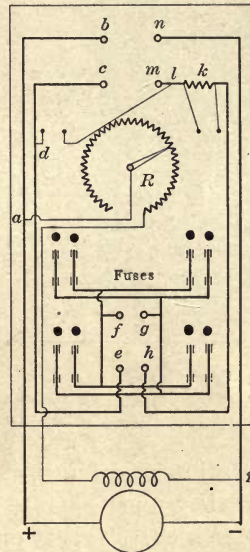

FIG. 419.

FIGS. 417 to 419.—Switchboard for a direct-current shunt generator, and four feeder circuits.

The exciter voltage is indicated by the voltmeter V_1 on the swinging bracket. As the station grows in size, a second exciter will have to be added to operate in parallel with the first but, by means of a plug P , the voltmeter V_1 may be made to indicate the voltage of each machine.

The generator panel is equipped with:

- 1 three phase indicating wattmeter.
- 1 ammeter.
- 1 voltmeter.
- 1 three phase watt-hour meter. (called in practice a recording wattmeter.)
- 1 handwheel for the alternator field rheostat R_2 .
- 1 field switch S_3 .
- 1 triple pole single throw (T. P. S. T.) oil switch.
- 1 current transformer C .
- 2 potential transformers V .

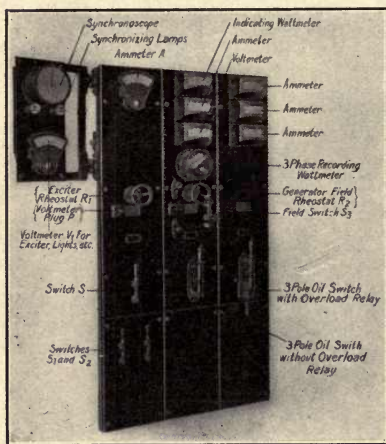

Switchboard

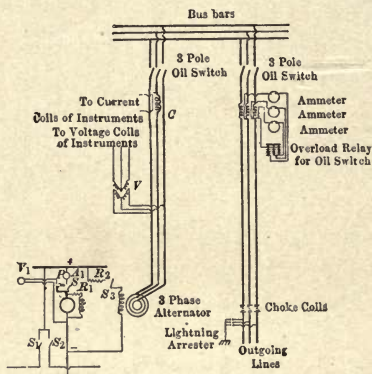

Connection diagram

FIG. 420.—Switchboard with an exciter panel, a three-phase alternator and a three-phase feeder panel.

As the station grows in size, additional alternators have to be added and they must operate in parallel so that a synchroscope must be provided. This is placed on the swinging bracket and the necessary connections are made by plugs on the generator panels. For a single alternator a synchroscope is not required.

The generator oil switch has no overload release; protection against overloads is provided for by the use of automatic switches on the feeder circuits.

The feeder panel is equipped with:

- 3 ammeters.
- 1 T.P.S.T. oil switch with overload release.
- 3 current transformers.

377. Instrument Transformers.—The instruments in circuits with a voltage of 2300 volts or greater are not connected directly in the circuit but are connected through transformers as shown diagrammatically in Fig. 421.

T is a potential transformer and is built exactly like a standard lighting transformer but on a smaller scale. The voltmeter *V* measures the secondary voltage but is calibrated in terms of the voltage of the primary side.

The series transformer has the primary side connected directly in the line and the secondary short circuited by an ammeter or by the current coils of a wattmeter.

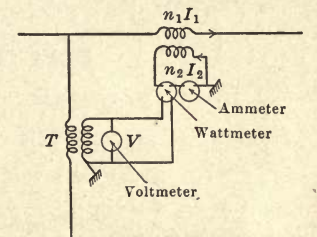

FIG. 421.—Connections of instrument transformers.

Since the secondary ampere turns of a transformer are always equal in number to the primary ampere turns therefore $n_2 I_2 = n_1 I_1$ or $I_2 = \frac{n_1}{n_2} I_1$ so that the current measured by the instruments is proportional to the current in the line.

CHAPTER XLII

ELECTRIC LIGHTING

A hot body gives off radiant energy in the form of heat, light and chemical energy and, to maintain the temperature of the body, energy must be given to the body at the same rate as it is dissipated by the body. An illuminant should have as much of the total radiation as possible in the form of light; power is required to maintain the other radiation but no light is obtained from it.

As the temperature of a body is raised, the color of its light changes from red to white, while its light efficiency increases rapidly, so that high temperature is a necessary condition for an illuminant of the incandescent type.

378. The carbon incandescent lamp consists of a filament of carbon enclosed in a glass globe from which the air has been exhausted. When the temperature of such a filament reaches about 1600°C ., the rate of evaporation of the carbon becomes excessive and the life of the filament becomes short. The life of such a lamp is the number of hours the lamp will burn before its candle power drops to 80 per cent. of the original value; the decrease in candle power is due largely to evaporation of carbon from the filament, this carbon deposits on the inside of the globe and blackens it.

If the voltage applied to a carbon lamp increases, the current increases, and so also does the temperature of the filament and the efficiency of the lamp, but the life is reduced. A standard 16 candle-power, 110 volt lamp takes 50 watts, or 3.1 watts per candle-power, with a life of about 500 hours; if the voltage is increased 2 per cent., the efficiency is increased about 7 per cent. and the life is reduced about 40 per cent.

379. The Tungsten Lamp has a filament of metallic tungsten. The temperature of such a filament can be maintained at about 2000°C ., which is higher than the operating temperature of a carbon filament, so that the tungsten lamp is the more efficient, taking only 1.2 watts per candle-power, and gives the whiter light. The

tungsten lamp is the more fragile of the two and the life of the lamp is not limited by a decrease in candle-power, but by the wear of the filament, which causes it to break after about 1000 hours of service.

A low-voltage lamp is more robust than a high-voltage lamp of the same candle-power, because the filament is shorter and of larger cross section, since it has to carry a larger current with a smaller voltage drop.

One important difference between tungsten and carbon is that, while the temperature coefficient of resistance of the former is positive, that of the latter is negative. Because of this, the tungsten lamp is less sensitive than the carbon lamp to voltage fluctuations. If for example the voltage is increased by k per cent., the corresponding increase of current in the tungsten lamp will be less than k per cent., because the resistance of the filament increases, while the increase of current in the carbon lamp will be greater than k per cent. because the resistance decreases. The effect of an increase in voltage is shown in the following table:

Voltage	Candle-power	Watts per candle-power	Life
Normal or 100%	100%	100%	100%
102%	111%	93%	60% carbon
	107%	96.3%	76% tungsten
98%	90%	106%	147% carbon
	93.3%	103.7%	125% tungsten

Because of the positive temperature coefficient of resistance, the tungsten lamp has a much lower resistance when cold than when hot, so that, when the lamp is switched on, the initial current is several times as large as the normal operating current. This result, called overshooting, reduces the life of a lamp if it is switched off and on frequently; for sign lighting, low-voltage lamps are used since they have a stouter filament than standard 110-volt lamps.

380. Gas-filled Tungsten Lamp.—If tungsten is heated in an atmosphere of nitrogen instead of in a vacuum, the temperature at which evaporation becomes excessive is higher in the former case than in the latter. Such nitrogen-filled lamps therefore have a high efficiency and, in large sizes, take only 0.5 watts per candle-power. Since the globe contains gas, convection currents are set

up when the lamp is lit, and the globe has the comparatively high temperature of about 200° C.

To obtain high efficiency from this lamp, it is found that the filament must be large in cross section; a filament to carry 20 amp. at 10 volts gives 2 candle-power per watt while a thinner filament to carry 5 amp. at 40 volts gives only 1.4 candle-power per watt. The lamp at its best efficiency cannot be made at present for less than about 350 candle-power, in which size it is suitable for the lighting of large areas at present lit by arc lamps of lower efficiency.

381. The Unit of Light.—The light giving power of a lamp is expressed in candle power. This, however, has little meaning

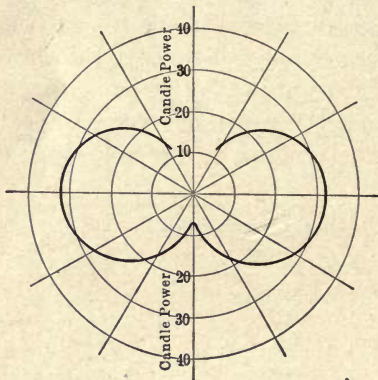

FIG. 422.—Light distribution in a vertical plane, from a 32 candle-power tungsten lamp.

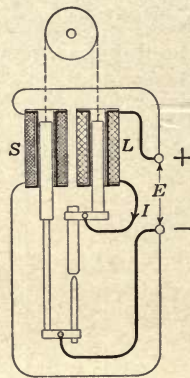

FIG. 423.—One type of arc-lamp mechanism.

unless the direction of the light is specified, and curves such as that in Fig. 422 are used for this purpose. This curve shows the distribution of light about the vertical plane of a tungsten lamp, and is obtained by measuring the candle power in different directions and then plotting along each radius a length proportional to the candle power in that direction.

Incandescent lamps are generally rated in mean horizontal candle power. Thus the lamp on which the curve in Fig. 422 was taken would be rated at 32 candle power although the average candle power in all directions, called the mean spherical candle power (m.s.c.p.) is only about 24 m.s.c.p.

382. Arc Lamps.—If two sticks of carbon connected in an electric circuit as shown in Fig. 423 are brought into contact, a

current will flow through the circuit and, since the contact between the carbons is poor and the resistance of the contact is therefore high, the carbons at the contact begin to glow, while a small quantity of carbon vapor passes between them.

If the carbon contacts are now separated by about a quarter of an inch, it will be found that the current still flows, because the space between the contacts is filled with carbon vapor which is conducting. The arc so formed is a powerful source of light.

An arc lamp consists of two sticks of carbon, with a mechanism which, when the voltage is applied, brings the carbons into contact and then separates them, and which also feeds the carbons together as they are consumed.

One of the many types of mechanism for this purpose is shown diagrammatically in Fig. 423. The upward pull of the shunt coil S tends to bring the carbons together, and this pull increases with the voltage E ; the upward pull of the series coil L increases with the current I and tends to separate the carbons. When the main switch is closed, a large current I passes through the coil L while the voltage E is comparatively small, so that the pull of L is greater than that of S and the carbons are separated. As they separate, E increases and I decreases and, when the arc has reached the proper length, then E and I have their normal values and the pulls balance.

383. The direct-current open arc takes the form shown in Fig. 425. The temperature of the positive tip is about 3700° C., the temperatures of the arc stream and of the negative tip are much lower. Of the total light from such an arc, 85 per cent. comes from the crater, 10 per cent. from the positive tip and 5 per cent. from the arc stream. The distribution of light from such an arc is shown by the polar curve in Fig. 424; directly below the arc the illumination is practically zero due to the shadow cast by the lower carbon.

Because of the high temperature, the light is white and the efficiency is high, but the life of the carbons is only about 10 hours.

384. Direct-current Enclosed Arc.—To cut down the trimming expense, the arc is enclosed in a globe which is almost air tight, so that after the first few seconds the arc is operating in an atmosphere of carbonic acid gas, and the carbons are consumed more slowly than in an open arc and have a life of about 100 hours. The arc is operating under slight pressure and, for satisfactory operation, the arc stream is longer than that of the open arc.

The crater is not now so pronounced, and a greater portion of the total light now comes from the arc stream, so that the light distribution in a horizontal direction is improved. Data on this arc is given in the table on page 360.

385. Alternating-current Enclosed Arc.—When operating with alternating current, the carbon arc lamp does not go out when the current passes through the zero value, because there is enough heat in the carbon tips to maintain the arc stream while the current reverses. Alternating-current arcs have no crater, and each tip is equally hot but is not so hot as the crater of a direct-current arc, so that the efficiency is lower, moreover the light is not directed downward but is directed horizontally, so that a reflector has to be supplied to deflect the light in the direction shown in Fig. 424.

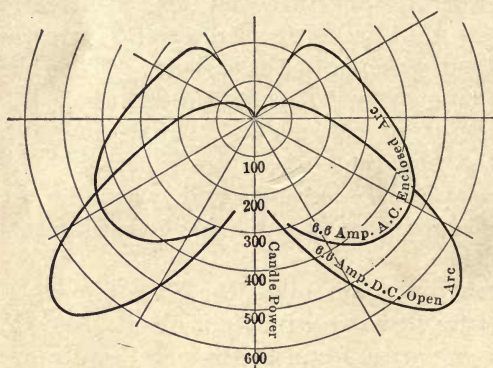

FIG. 424.—Light distribution of arc lamps.

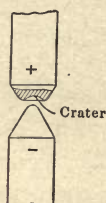

FIG. 425.—Shape of a direct-current arc.

386. Flame Arc Lamps.—The positive carbon of the direct-current flame arc lamp and either or both carbons of the alternating current flame arc are impregnated with salts which have high selective radiation. Such salts when heated give most of their radiation in one particular part of the spectrum. Being selective, the portion of the total radiation which is given off as light is greater than that given off by an ordinary incandescent body at the same temperature, such lamps are therefore very efficient, and a large portion of the light comes from the arc stream. Calcium salts are often used and give a yellow light. Barium salts give a white light, but the white flame arc is not so efficient as the yellow flame arc.

The open flame arc requires daily trimming. If the arc is enclosed so as to limit the supply of air, the life of the carbons may be increased to 100 hours without any marked reduction in the efficiency. The enclosing globe, however, must be kept free from soot, by arranging that the fumes shall be carried away and allowed to deposit in a condensing chamber and not on the sides of the enclosing globe.

387. Luminous Arc Lamp.—This is a low temperature arc which depends entirely on selective radiation for its efficiency. It is essentially a direct-current arc and has a positive electrode of copper and a negative electrode of magnetite. Magnetite boils at a much lower temperature than carbon, and the temperature of the arc is not high enough to melt the copper or to enable the arc to be used on alternating current; the arc goes out as the current passes through zero.

The efficiency is not so high as that of the flame arc. The light is white, and the magnetite electrode has a life of about 150 hours while that of the copper electrode exceeds 1000 hours. The magnetite arc must never be connected with the polarity reversed because, if the copper were made the negative electrode, a copper arc would be produced instead of a magnetite arc, since the material of the arc stream comes from the negative electrode.

For alternating-current circuits, titanium arcs are being developed, which have an efficiency comparable with that of the flame arc.

388. Mercury Vapor Converter.—To obtain direct-current from an alternating-current supply for the operation of magnetite arcs, the mercury vapor converter is used.

The globe shown in Fig. 426 is filled with mercury vapor. It is found that a very high voltage is required to start an arc between *a* and *b* but about 14 volts is all that is required to maintain the arc; there is a high resistance at the negative electrode which resistance is broken down when current is flowing, but is reestablished as soon as the current ceases to flow. Alternating current cannot pass between the electrodes because the high resistance is reestablished as the current passes through the zero value.

To operate as a converter, the globe is fitted with three electrodes and is connected up as shown in Fig. 428, and means are provided whereby the resistance of electrode *c* is kept broken down. At the instant shown in Fig. 428, the electrode *a* is posi-

tive and that of b is negative, so that current passes from a to c but no current can pass from a to b or from c to b , because of the high resistance of negative electrode b . Half a cycle later b is positive and a is negative, so that current can pass from b to c but no current can enter a . The current in the line L therefore flows always in one direction or is a direct current.

There is a small reactance coil S , called a sustaining coil, placed in the line L to carry the rectifier over the point of zero current. This coil causes the current to lag slightly behind the e.m.f. so that there is still a small current flowing from a , for exam-

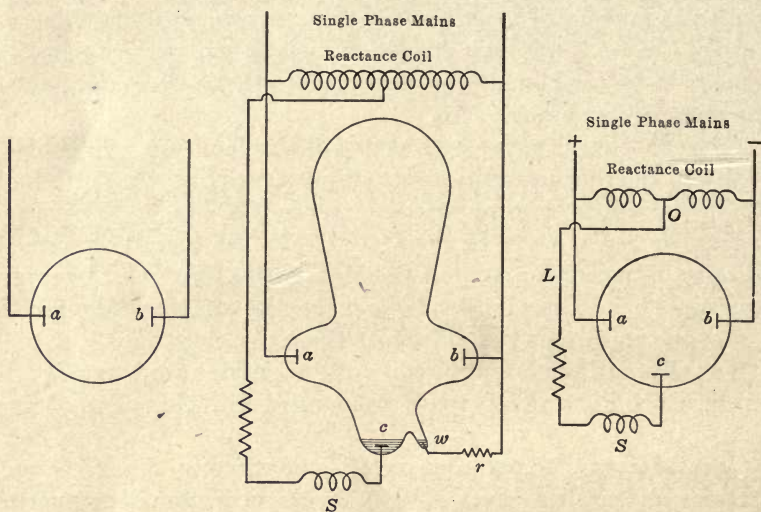

FIG. 426.

FIG. 427.

FIG. 428.

FIGS. 426 to 428.—The mercury-vapor converter.

ple, when the arc from b is ready to strike. The current entering c therefore never becomes zero and the high negative resistance of that electrode is always broken down.

Before such a converter can be started, the resistance at c must first be broken down. To accomplish this result an additional starting electrode is placed at w and current is passed between w and c by tipping the globe until the mercury forms a bridge between these two electrodes. The tube is then raised and an arc is drawn between w and c for half a cycle, which breaks down the resistance of c long enough to allow the arc to start from b and thereby start the rectifier in operation.

389. Mercury Vapor Lamp.—The converter described above is an arc lamp and, since the light is due to the selective radiation of mercury vapor, it is a high efficiency lamp. Unfortunately the color is greenish blue and gives ghastly color effects.

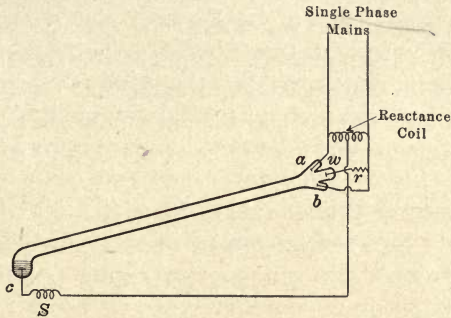

FIG. 429.—Mercury-vapour lamp for operation by alternating-current.

The alternating-current lamp is made in the form shown in Fig. 429, which is lettered similarly to Fig. 427. To start the arc, the lamp is tipped so that the mercury runs down and forms a metallic connection between the two electrodes through which a current flows, the lamp is then allowed to return to its original position, the mercury thread is ruptured, and an arc follows.

The direct-current lamp is supplied with two terminals and is started in the same way.

When a quartz tube is used instead of a glass tube, the lamp may be shortened, and run at a higher temperature with a higher efficiency.

390. Shades and Reflectors.

—The light distribution from a source can be completely changed by the use of a shade or reflector. Curve A, Fig. 430, shows the light distribution from a tungsten lamp while curves B, C and D show the distribution when

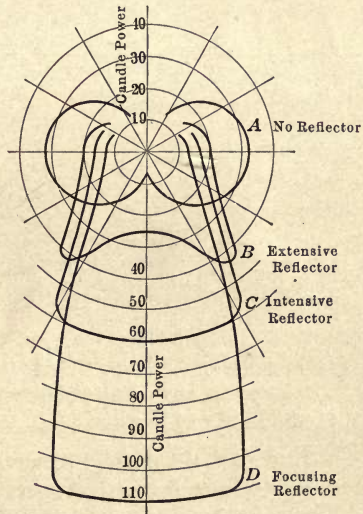

FIG. 430.—Light distribution of a 32 candle-power tungsten lamp equipped with different reflectors.

different types of reflectors are used. Curve *B* is obtained with what is called an extensive reflector, curve *C* with an intensive reflector, and curve *D* with a focusing reflector.

When the distance between the lamps is at least twice the height of the lamp above the ground, the extensive type is used; it is suitable for a small room lit by a source placed on the centre of the ceiling. When the distance between lamps is about one and a half times the mounting height, the intensive type is preferred; it is suitable for a large room lit from several points on the ceiling. The focusing type is used when the lamps are more closely spaced and is suitable for the illumination of desks, show cases, etc.

391. Efficiency of Illuminants.—Since the light from a source can be suitably directed by means of reflectors, light efficiency should be based on the mean spherical candle power of the lamp. Values attained in practice are given below¹

	Mean spherical candle power per watt	Candle power at 10° angle per watt	Available size in mean spherical candle power
Incandescent lamps			
Ordinary carbon filament	0.21	0.4	any size
Tungsten filament	0.64	1.25	any size
Gas-filled tungsten	1.28	2.5	above 350
Arc lamps			
Enclosed carbon			
6.6 amp., 450 watts A.C.	0.39	0.5	175
6.6 amp., 480 watts D.C.	0.62	1.0	300
Flame carbon			
500 watts, yellow	3.1	6.2	1550
300 watts, yellow	1.95	4.0	585
500 watts, white	1.95	4.0	975
D.C. magnetite			
4 amp., 300 watts	1.0	2.2	300
6.6 amp., 500 watts	1.5	3.2	750
A.C. titanium			
220 watts	1.9	4.0	420
Mercury lamps			
glass tube	1.55		
quartz tube	2.0		

These figures take account of the loss in the reflectors, and the candle power at 10° angle below the horizontal is that obtained when the lamp is equipped with a reflector suitable for street lighting.

¹ Efficiency of Illuminants by C. P. Steinmetz, General Electric Review, March, 1914.

392. Light and Sensation.—The eye is able to see objects distinctly over a range of intensity of 1,000,000 to 1 as determined by the exposure of a photographic plate. The size of the pupil is controlled automatically by the intensity of the light and decreases as the light intensity increases so as to limit the amount of light that can enter the eye. The sensibility of the optic nerve also changes automatically with the light intensity but at a much slower rate; when one goes from daylight into a darkened room, for example, objects that at first are invisible become quite distinct after a time.

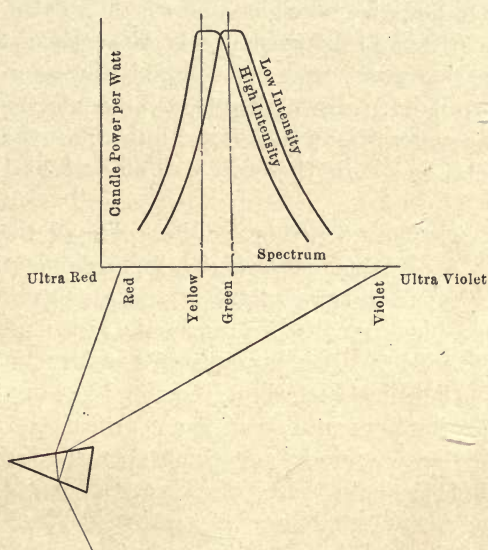

FIG. 431.—Effect of color on the light efficiency.

The light sensation produced by a given amount of radiant power entering the eye depends on the color of the light. White light is composite and, when passed through a prism, as shown in Fig. 431, is divided up into its constituents and produces a band of color varying from red to violet called the spectrum.

The relation between candle-power per watt and color is shown in Fig. 431; with a high light intensity the eye is most sensitive to yellow light while with a low intensity it is most sensitive to green light. If for example a mercury vapor lamp and a yellow flame arc burning side by side have the same brightness at a moderate distance from the observer, then, when the lamps are close at hand the flame arc appears the brighter since the light

intensity is high, but when the lamps are a considerable distance away the intensity is low and the green mercury lamp appears the brighter. A yellow light is therefore the most efficient for high intensity illumination and a green light the most efficient for low intensities; these colors however are often objectionable. There is one important exception; yellow light is used for fog signal work because it penetrates fog better than does green light.

393. Reflection and Color.—When light strikes an opaque body, some of the light is absorbed and some is reflected. The color of an opaque body is the color of the light which it reflects, a green opaque body is one which absorbs all but the green rays.

When light strikes a transparent body, the color of the body as seen from the side away from the source is the color of the light which is transmitted; a green glass transmits only the green rays, whereas a transparent body transmits all the light that falls on it, a colored globe on a lamp therefore cuts off light and reduces the efficiency.

The color of a body depends on the color of the light that strikes on it. An opaque body which is yellow in daylight reflects only yellow rays; in the green light of the mercury vapor lamp this body looks black because it absorbs the green light and there is no yellow to reflect. It is important therefore that colors be matched in the light in which they are going to be used.

The color of the light in a room is not always the color of the source. If daylight enters a room which has walls of a green color, then the bulk of the light that strikes the walls is absorbed while the green rays are reflected and a green tint is added to the light in the room. Dark walls and ceilings result in low efficiency of illumination. In an ordinary room, about 70 per cent. of the light from the source strikes the walls and, if the paper is dark, most of this light is absorbed and lost, if the paper is light yellow in color, a large part of the light is reflected and is useful.

Red wall papers and table cloths are to be avoided in a reading room because, under such circumstances, a large part of the light that enters the eye is red light and, for a given distinctness of vision, a larger amount of energy must enter the eye if the light is red than if yellow or white, see Fig. 431, page 361, and the excessive amount of energy is harmful to the eye tissues.

394. Principles of Illumination.—For satisfactory illumination, the light should be of good quality, glare should be avoided, and the shadows should be distinct so as to give good perspective.

395. Quality of the Light.—The light should be as nearly white as possible. Most of the harm done by artificial illumination is due to the red and ultra red rays for the reason just pointed out. Green light also is harmful under certain circumstances because it is found that the pupil fails to respond to variations in intensity of light of this color. Green light should therefore not be used for high intensity illumination, as for example for the lighting of drawing offices, but, as pointed out on page 362, it is particularly suited for low intensity illumination. Ultra red and ultra violet radiation is the most harmful and there is much of the latter in arc lamps, so that an arc should always be enclosed in a glass globe since glass is opaque to such radiation.

Flickering light is bad for the eye because the pupil tries to adjust itself to the rapidly varying intensity and becomes fatigued. Alternating current lighting at 25 cycles has not been uniformly successful for this reason.

396. Glare.—The eye cannot look with comfort on objects which have a higher surface intensity than 4 candle power per square inch, so that the sources of illumination should be kept out of the range of vision, and direct reflection into the eye from such sources should also be avoided. Side lights and light from below are particularly objectionable since the eye is not protected from such light.

If the source of illumination cannot be kept out of the range of vision, then frosted incandescent lamps should be used or the lamp supplied with a shade or globe that will keep the direct rays away from the eye.

It is impossible to see distinctly past a bright light and for that reason country roads should not be lit by powerful arc lamps spaced far apart because, not only does most of the light go to illuminate the adjoining fields, but the arcs are generally hung so low to clear the trees that it is impossible to see past them, and driving on such roads is dangerous. Incandescent lamps of moderate candle power, spaced closer together, give better illumination.

397. Shadows.—In certain cases as for example for the illumination of drafting rooms it is desirable to eliminate shadows. This result is obtained by the use of a large number of light sources, or by the use of indirect methods of lighting whereby a reflector is used to throw all the light on to the ceiling from which it is reflected on to the drawing tables.

For other classes of work, such as street lighting, diffusion is to be avoided since, due to the elimination of shadows, there is loss of perspective and obstacles are not clearly seen.

398. Intensity of Illumination.—The unit of light intensity is that produced by a source of one candle-power at a distance of 1 ft. and is called the foot-candle.

In Fig. 432, the same amount of light strikes the surfaces *A*, *B* and *C*, so that the intensity at *B* is less than that at *A* in the ratio a_r^2/b_r^2 , or intensity is inversely proportional to the square of the distance. Again the intensity on surface *C* is less than that at *B* in the ratio area *B*/area *C* = $\cos \alpha$.

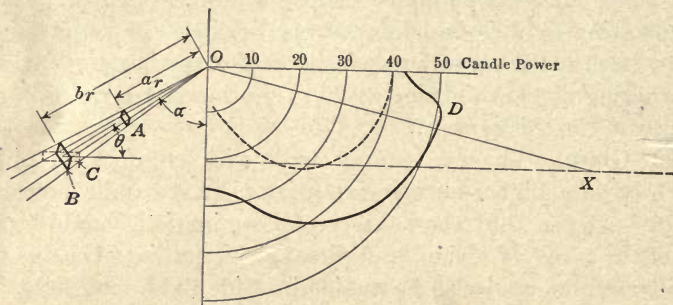

FIG. 432.—Variations of light intensity with the distance from the source, and with the angle of incidence.

Curve *D*, Fig. 432, shows the light distribution curve of a 40-candle-power tungsten lamp equipped with a reflector for street lighting. It is required to determine the illumination at a point *X*, 50 ft. from the post, the height of the lamp being 12 ft.

The candle-power in direction $OX = 51$

The distance $OX = \sqrt{50^2 + 12^2} = 51.5$ ft.

The intensity on an obstacle normal to the light

$$= \frac{51}{(51.5)^2} = 0.0192 \text{ ft.-candle}$$

The intensity on the street surface = $0.0192 \times \cos \alpha$

$$= 0.0192 \times \frac{12}{51.5} = 0.0045 \text{ ft.-candles.}$$

The minimum intensity on the street surface due to two lamps spaced 100 ft. apart = $2 \times 0.0045 = 0.009$ ft.-candles. For country roads, the minimum intensity on an obstacle normal to the light should not be less than 0.02 ft.-candles.

399. Lines of Illumination.—It is convenient to represent the total light from a source by lines of illumination, called lumens,

such that the number crossing unit area placed perpendicular to the direction of the light is made proportional to the light intensity. One foot-candle is represented by one line per sq. ft.

If a source of one candle-power were surrounded by a sphere of 1 ft. radius, the intensity at the surface of the sphere would be 1 ft.-candle, there must therefore be one line per sq. ft. or a total of 4π lines.

To provide for a surface intensity of I ft.-candles over an area of A sq. ft.

$$\text{The number of lines of illumination} = I \times A$$

$$\text{The candle-power of the source} = \frac{I \times A}{4\pi}$$

Since some of the light is absorbed by walls and ceilings

$$\text{the necessary candle-power} = \frac{I \times A}{4\pi \times k}$$

where $k = \frac{\text{useful light}}{\text{total light}}$ is less than 1; average values are

$$k = 0.6 \text{ if clear reflectors are used and the room has light walls and ceiling.}$$

$$= 0.4 \text{ with clear reflectors and dark walls and ceiling.}$$

Determine the candle-power required to give a light intensity of 3 ft.-candles over a room which is 40 ft. long and 30 ft. wide the room having light walls and ceiling.¹

The necessary candle-power = $\frac{3 \times 40 \times 30}{4\pi \times 0.6} = 477$ candle-power. A 40-watt lamp gives $40/1.25 = 32$ horizontal candle-power and 24 mean spherical candle-power, see page 354, so that $\frac{477}{24} = 20$ lamps of 40 watts each are required, or a smaller number of lamps of larger candle-power. The choice of the candle-power of each lamp, and the spacing of the lamps, is a matter that must be left to the judgment of the individual; there are many examples of good and of bad illumination to be found in every city.

In the above problem

$$\text{The total power required} = 20 \times 40 = 800 \text{ watts}$$

$$\text{The watts per sq. ft.} = 800/(40 \times 30) = 0.75.$$

400. Power Distribution for Lighting.—Interior lighting is generally carried out at 110 volts, either alternating or direct current, the lamps being connected in parallel across the circuit.

When arc lamps are connected across such a circuit, a steady-ing resistance must be placed in series with the arc as shown in Fig. 433. Suppose an arc is carrying a current I with a constant

¹ A list of economical intensities for all classes of work will be found in the American Electricians' Handbook by Terrell Croft.

voltage E at the terminals. If the current I were to increase for an instant, more carbon vapor would leave the negative electrode, the arc stream would become more conducting, and the current I would increase still further, so that an arc is unstable when used

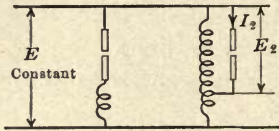
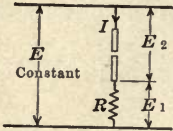

FIG. 433.—Direct-current. FIG. 434.—Alternating-current.
 FIGS. 433 and 434.—Multiple arcs.

on constant potential. If, however, a resistance is placed in series with the arc, as shown in Fig. 433, then an increase in the current I causes the voltage $E_1 = IR$ to increase, and therefore the arc voltage E_2 to decrease so that it cannot maintain the increased current across the arc.

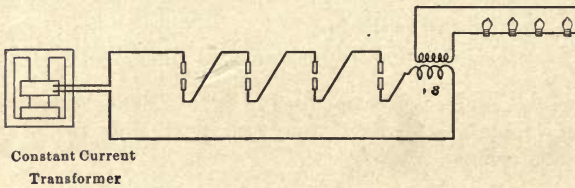

FIG. 435.—Alternating-current system.

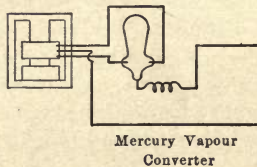

FIG. 436.—Direct-current system.
 Series connection of lamps.

In the case of alternating-current parallel arcs a steadying reactance is used, because it consumes very little power and still reduces the voltage. The same result may be obtained by supplying the lamp through an autotransformer since the secondary voltage E_2 , Fig. 434, decreases with an increase of the arc current I_2 .

If the lamps can be used in a series circuit, as shown in Fig. 435, then the wire has to carry the current of only one lamp and

may be small in cross section. This system of distribution is largely used for street lighting, the constant current required for the operation of the arcs being obtained by means of a constant current transformer, see page 267.

By means of a series transformer it is possible to connect a circuit of tungsten lamps taking a large current in series with a main circuit of arc lamps taking a smaller current.

For the operation of magnetite arcs, direct current is necessary and this is obtained by means of a mercury vapor converter connected as shown in Fig. 436.

The voltage between electrodes should be about:

- 47 volts for an open carbon arc,
- 72 volts for an enclosed carbon arc,
- 45 volts for an open flame arc,
- 78 volts for open magnetite arc.

CHAPTER XLIII

LABORATORY COURSE

401. Protection of Circuits.—A typical circuit is shown in Fig. 437. The lamps L take power from the mains and the current I is measured by the ammeter A while the voltage E is measured by the voltmeter V , see page 19.

All the connections should be made before the switch S is closed, and the circuit must be protected by fuses F , see page 117, or by an automatic circuit breaker, see page 39, set so as to open the circuit if the current should become large enough to injure any of the apparatus connected in the circuit.

To make sure that the instruments are reading in the proper direction, the switch S should be closed for an instant and then

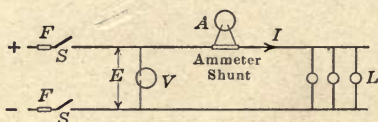

FIG. 437.—Typical circuit.

opened before any appreciable current has had time to flow. If the needle moves in the wrong direction, the instrument connections must be reversed.

402. Ammeter Shunts.—Most ammeters are wound with very fine wire, see page 8, and can carry only a small fraction of an ampere without being burnt out. To use such instruments for the measurement of large currents they must be connected in parallel with shunts as shown in Fig. 437. The current in the instrument, and therefore the deflection, will be proportional to the line current I so that, if the shunt and instrument are always used together, the scale of the instrument may be in terms of the line current to be measured and not in terms of the current in the instrument. For instruments with a range of less than 5 amperes, the shunt is generally placed inside the case.

403. Safe Carrying Capacity of Copper Wires.—If too large a current flows in an insulated wire, the insulation will be

damaged. The values given in the following table should not be exceeded.

Size of wire, Brown & Sharpe gauge number	Diameter of wire in inches	Maximum current in the wire in amperes	
		Rubber insulation	Other insulation
14	0.064	12	16
12	0.081	17	23
10	0.102	24	32
8	0.128	33	46
6	0.162	46	65
5	0.182	54	77
4	0.204	65	92
3	0.229	76	110
2	0.258	90	131
1	0.289	107	156
0	0.325	127	185

404. Control of the Current in a Circuit.—To vary the current flowing in the coil C , Fig. 438, an adjustable resistance R is inserted in the circuit, see page 25. This rheostat must be able to carry the current I without overheating.

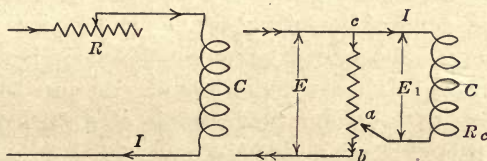

FIG. 438.

FIG. 439.

FIGS. 438 and 439.—Methods of controlling the current in a circuit.

If the resistance of the coil C is large compared with that of the resistance R , then the current variation will not be very large. Under such circumstances, the potentiometer connection shown in Fig. 439 is to be preferred for experimental work. If the movable contact a is placed at b then the voltage E_1 is equal to E , the line voltage. If contact a is placed at c , then the voltage E_1 is zero. By moving the contact between these two points, the voltage E_1 and the current I may have any value from zero to $E_1 = E$ and $I = E/R_c$. If the resistance R_c is small and the contact a is close to b , as shown in Fig. 439, then the current in ab may become dangerously large, so that the rheostat must

be watched during operation and the circuit opened if the rheostat becomes too hot.

EXPERIMENT 1

Object of Experiment.—To determine the resistance of the shunt field circuit of a direct-current machine with different values of current in the circuit.

Reference.—Pages 20 and 95.

Connections.—If the connection in Fig. 440 does not give sufficient range of current, then use the connection shown in Fig. 439.

Readings.—Volts and amperes.

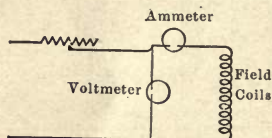

FIG. 440.

Report.—Describe the method of carrying out the experiment and embody the answers to the following questions in the report.¹

1. Find the resistance of the field coil circuit.
2. How does temperature affect this resistance? Show the result experimentally by measuring the resistance after the current has been flowing for 30 minutes.
3. What per cent. of the output of the machine is the excitation loss? The machine output is given on the name plate.
4. What range of instruments would you use to determine the resistance of the shunt field circuit of a 50 kw., 240 volt generator if the excitation loss is known to be less than 4 per cent.?

EXPERIMENT 2

Object of Experiment.—To determine the resistance of the armature circuit of a direct-current machine with different values of current in the circuit.

Connections.—See. Fig. 438, page 369. The rheostat used to control the current must be able to carry the full-load armature current of the machine without injury.

Readings.—Volts across the terminals; volts across the commutator, obtained by attaching the voltmeter leads to the segments which are under the brushes; amperes.

Report.—Describe the method of carrying out the experiment and embody the answers to the following questions in the report:

1. Plot the armature resistance against current.
2. Plot the brush contact resistance against current.
3. What per cent. of the output of the machine are the armature resistance loss and the brush contact resistance loss at full-load?
4. Has the pressure on the brushes much effect on the brush contact resistance? try the experiment. What do you imagine limits the brush pressure?
5. What range of instruments would you use to determine the resistance of the armature circuit of a 50-kw., 240-volt generator if the loss in the complete armature circuit is known to be less than 4 per cent. at full-load?

EXPERIMENT 3

Object of Experiment.—To find how the speed of a direct current shunt motor at no-load varies with:

- a. The exciting current; armature voltage being constant.
- b. The armature voltage; exciting current being constant.

References.—Pages 85 and 89.

Connection. Fig. 441.

Readings.—Exciting current; armature voltage; speed.

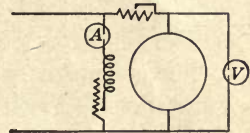

FIG. 441.

Curves a. Speed and exciting current.

b. Speed and armature voltage.

Questions.—1. Explain the shape of the curves, without formulæ

2. What would happen if, in starting up a shunt motor, a starting resistance was not placed in series with the armature circuit? How many times full-load current would flow through the armature under these conditions? (Use the value of armature resistance determined in the last experiment.)

3. What is the back e.m.f. of a motor and what relation has it to the applied e.m.f.? Perform the experiment described in Art. 88, page 79, to answer this question.

4. What would happen if, during operation, the field coil circuit were to open (do not perform this experiment)?

5. Draw a diagram of connections of any starter in the laboratory, which has a no-voltage release and also overload protection.

EXPERIMENT 4

Object of Experiment.—To find how the voltage of a direct-current generator at no-load varies with:

a. The exciting current; speed being constant.

b. The speed; exciting current being constant.

Reference.—Page 70.

Connection.—See Fig. 95, page 70.

Readings.—Voltage, exciting current and speed.

Curves *a.* Voltage and exciting current.

b. Voltage and speed.

Questions.—1. Why is there a small voltage even with no exciting current?

2. Explain the shape of the curves.

3. How would you reverse the polarity of the generator, *i.e.*, how reverse the direction of the voltage?

EXPERIMENT 5

Object of Experiment.—To determine how the terminal voltage of a constant speed generator varies with the load:

a. The generator being separately excited;

b. The generator being shunt excited;

c. The generator being compound excited.

References.—Pages 71 to 77.

Connections.—See Fig. 97, page 72; Fig. 98, Fig. 99.

Readings.—Terminal voltage, line current, exciting current and speed.

Curves.—Terminal voltage on a line current base.

Shunt exciting current on a line current base.

Questions.—1. Why does the terminal voltage of a separately excited generator decrease with increase of load? How much of the drop at full-load is due to armature resistance?

2. Why is the voltage drop greater in a shunt than in a separately excited generator?

3. What would be the effect of shifting the brushes further forward from the neutral position?

4. What is the principal advantage of the compound generator?

5. How would the terminal voltage of a compound generator vary with increase of load if the series field coils were connected so as to oppose the shunt coils?

6. If the generator is overcompounded while flat compounding is desired, what can be done to fix the machine?

7. If the voltage of a shunt generator builds up when the generator rotates in a given direction, why will it not build up if the direction of rotation is reversed? Try the experiment.

EXPERIMENT 6

Object of Experiment.—To determine the efficiency and also the speed and torque characteristics of shunt, series, and compound motors, by loading the machines by means of a brake, the applied voltage being constant.

References.—Chaps. XV, XVII and XVIII.

Connections.—Fig. 107, page 86, Fig. 113 and Fig. 117.

Readings.—Applied voltage (constant), armature current, shunt exciting current (constant), speed, brake reading.

Curves.—Speed and torque on an armature current base. Brake horse-power and total input on an armature current base. Efficiency on a brake horse-power base.

Questions.—1. How would you reverse the direction of rotation of each machine?

2. For what type of service is each machine suited?

3. The field coils of a machine become hot during operation, what effect will this have on the no-load and on the full-load speed of each type of motor?

4. How can the speed of each type of motor be varied for a given load?

5. Why is the speed regulation of a shunt motor poor when the speed is controlled by a resistance in the armature circuit? Try the experiment.

6. Explain without formulæ, the shapes of the speed, torque, and efficiency curves.

EXPERIMENT 7

Object of Experiment.—To determine the relation between starting torque and armature current in a shunt, a series, and a compound motor.

References.—Pages 85 and 90.

Connections.—Same as for experiment 6, with resistance in the armature circuit to limit the current (do not use a starting box for this purpose).

Readings.—Armature current and brake reading.

Curves.—Torque on an armature current base.

Questions.—1. How does the starting torque compare with the running torque, as determined in experiment 6, for the same armature current? Does theory indicate that there should be a difference?

2. Why is the series motor preferred for heavy starting duty?

EXPERIMENT 8

Object of Experiment.—To measure the stray loss, the armature copper loss, and the excitation loss in a shunt motor, and calculate the efficiency from these figures.

Reference.—Chap. XVI, page 95.

The work of this experiment should be done without instruction. A diagram of connections should be drawn out and the range of the necessary instruments determined before the apparatus is connected up.

Report.—Describe the method of carrying out the experiment. Plot the efficiency curve on a horse-power output base up to 25 per cent. overload, and compare this curve with that obtained by brake readings in experiment 6; if the results show considerable difference, which would you consider to be the more reliable?

EXPERIMENT 9

Object of Experiment. To run a shunt generator in parallel with the power house and determine the temperature rise of the machine at full-load.

References.—Pages 21, 99 and 163.

Connection.—Fig. 179, page 164.

Readings.—Measure the resistance of the field coil circuit at the beginning of the test and every ten minutes thereafter, take also readings of temperature of the field coil surface at the same time. Find the temperature of the armature core and armature winding immediately the generator is shut down; the heat run should last for at least an hour and a half.

Curves.—Observed temperature rise of field coil surface, and also the temperature rise determined by resistance measurements, on a time base.

Questions.—1. Explain the shape of the curves.

2. Why is the temperature rise of the field coils as determined by resistance measurements greater than that determined by thermometer?

EXPERIMENT 10

Object of Experiment.—To determine the voltage regulation of a three wire system.

References.—Pages 316, 317 and 338.

Connections.—Use a balancer set, see Fig. 374, or a three-wire

generator. If these are not available, a single-phase rotary converter with a suitable autotransformer may be connected up as shown in Fig. 442 to form a three-wire generator.

Readings.—Vary the loads on the two sides of the system from perfect balance, when $A_1 = A_2$ and A_n is zero, to a maximum of unbalance when the load on one side of the line is zero. Take readings of V_1 , V_2 , A_1 , and A_2 ; $V_1 + V_2$ to be kept constant.

Curves.—Plot V_1 and V_2 against the unbalanced current $A_1 - A_2$.

Questions.—1. Explain the action of the apparatus used.

2. What are the advantages of the three-wire over the two-wire system of distribution?

3. Explain the shapes of the curves.

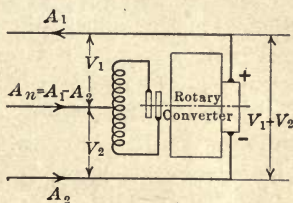

FIG. 442.

EXPERIMENT 11

Object of Experiment.—To determine the characteristics of fuse wire.

Reference. Page 117.

Connection. Fig. 443.

Readings.—Length of wire between blocks, average current, time taken for fuse to melt after switch S is closed.

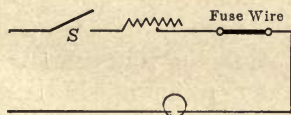

FIG. 443.

Curves.—Plot amperes on a time base for four lengths of fuse wire and from these curves plot another set with amperes on a length base for a fusing time of 10 sec.

Questions.—1. Explain the shape of the curves.

2. If a fuse is rated at 5 amp., about what current would you expect it to carry continuously, and what current for 30 sec.?

EXPERIMENT 12

Object of Experiment.—To calibrate a circuit breaker.

Reference. Page 39.

Connections.—Same as for fuse testing.

Readings.—Amperes to open, and position of plunger.

Curve.—Draw a current scale that could be attached to the circuit breaker.

Questions.—1. Explain the construction and the operation of the circuit breaker used.

2. What are the advantages and disadvantages of circuit breakers and fuses, for what type of circuit is each suited?

3. If a 10 amp. fuse, and a circuit breaker set for 15 amp., are used to protect the same circuit, which would open first in the case of an overload on the circuit.

4. If a circuit breaker and a switch are both in a circuit, as in Fig. 417, page 349, which would you close first?

EXPERIMENT 13

Object of Experiment.—To determine the effect of change of frequency on the constants of an alternating-current circuit.

Reference. Chaps. XXIX and XXX.

Connection. Fig. 444.

Readings.—Vary the alternator speed and adjust the alter-

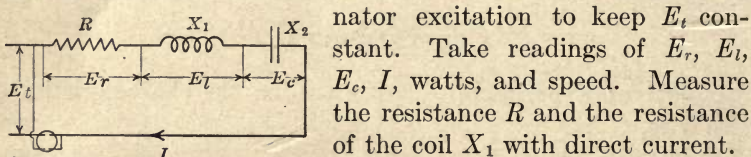

FIG. 444.

nator excitation to keep E_t constant. Take readings of E_r , E_l , E_c , I , watts, and speed. Measure the resistance R and the resistance of the coil X_1 with direct current.

Curves.—On a frequency base, plot the inductive reactance $X_1 = E_l/I$, the capacity reactance $X_2 = E_c/I$, the resistance R , and the power factor $\left(\frac{W}{E_t I}\right)$.

Questions.—1. For any one frequency, draw the voltage vector diagram to scale, and compare the value of E_t so found with that found experimentally.

2. Calculate the coefficient of self induction of the coil X_1 and the capacity of the condenser X_2 .

3. What is meant by resonance? At what frequency does it occur in this experiment and how does that frequency compare with the theoretical value $f = \frac{1}{4\pi\sqrt{LC}}$?

4. Explain the shape of the power factor curve.

5. Under what conditions can the voltage E_l be greater than the applied voltage E_t ?

EXPERIMENT 14

Object of Experiment.—To predetermine the characteristics of a given circuit and compare the results with those obtained by actual test.

Reference. Chaps. XXIX and XXX.

Connection.—Use the same resistance, inductance, and capacity as in the last experiment and connect as in Fig. 445.

Curves.—Predetermine the values of E_r , E_x , I_l , I_c and I , with E_t , the normal voltage of the alternator, the same as in the last experiment. Plot these values against frequency, then determine the same curves by test and compare the results.

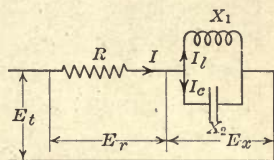

FIG. 445.

EXPERIMENT 15

Object of Experiment.—To determine the characteristics of a transformer.

References. Chap. XXXIV, page 261.

Connections.—A low voltage transformer should be used, connected as shown in Fig. 446, or else two like transformers connected as shown in Fig. 447 with the high-voltage leads taped up.

Readings.—Keep E_1 , the secondary power factor W_2/E_2I_2 , and the frequency all constant, and take readings of E_1 , I_1 , W_1 , E_2 , I_2 , and W_2 for values of I_2 from zero up to 25 per cent. over-load. Measure also the resistances of the primary and the secondary windings with direct current.



FIG. 446.

FIG. 447.

secondary windings with direct current.

Curves.—Plot efficiency (W_2/W_1), voltage V_2 , and primary and secondary power factors against I_2 .

Questions.—1. Why is the primary power factor less than that of the secondary particularly at light loads?

2. Why does the voltage E_2 decrease with increase of load, and why is the voltage drop greater with inductive than with non-inductive load?

3. Calculate the resistance loss in the windings at full-load. Find also by calculation the full-load efficiency and compare the result with that determined by test.

4. If the transformer is connected to the line for 24 hours a day, but carries full-load for only 5 hours a day, find the all day efficiency.

EXPERIMENT 16

Object of Experiment.—To predetermine the regulation curves of a single-phase alternator at 100 per cent., 80 per cent. and

zero power factors, from no-load saturation and short-circuit curves, and compare the result at 100 per cent. power factor with that found by actual load test. (A lamp bank has a power factor of approximately 100 per cent.)

Reference. XXXII, page 244.

Connections. Fig. 287, page 247.

Readings.—*a.* No-load saturation; armature volts and field current at constant speed.

b. Short-circuit; armature amperes and field current at the same speed.

c. Load curve; terminal voltage and armature current with constant field excitation and the same constant speed.

d. Measure the armature resistance with direct current.

Curves.—*a.* No-load saturation; armature voltage on a field current base.

b. Short circuit; armature current on a field current base.

c. Armature reactance determined from curves *a* and *b* plotted on a field current base.

d. Load curve; terminal voltage on an armature current base, by calculation at 100 per cent., 80 per cent. and zero power factors, and by test at 100 per cent. power factor.

Questions.—1. Why is the power factor of a bank of incandescent lamps approximately equal to 100 per cent.

2. Give the theory of the method used to determine the reactance of the armature of the alternator.

3. Why does the voltage drop more rapidly at low power factors than at high power factors?

4. Why are alternators rated in kilovolt-amperes and not in kilowatts?

5. How is the voltage of an alternator maintained constant in practice, at all loads and power factors?

EXPERIMENT 17

Object of Experiment.—To start up a synchronous motor and determine its running characteristics.

Reference. Chap. XXXIII, page 252, also page 296.

Connections.—Fig. 398, page 258, for single phase machines. For three phase machines use the connection in Fig. 448.

Method of Starting.—Start up the synchronous motor by means of the belted direct-current motor *M* and adjust the speed

of the synchronous motor and its excitation until the voltage E_2 is equal to E_1 and the synchronizing lamps all remain dark for a few seconds at a time. (If all the lamps do not become dark at the same instant then interchange two of the motor leads.)

When all three lamps are dark at the same instant, then close the three switches S_1 , S_2 and S_3 at the same time. The starting motor can then be disconnected by throwing the belt, and the synchronous motor loaded by means of a prony brake.

Readings.—With the applied voltage E_2 , the frequency, and the brake readings all constant; take readings of current I and of watts ($W_1 + W_2$) for different values of the exciting current I_f and for three different settings of the brake.

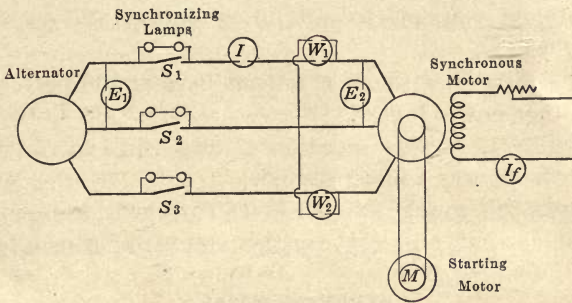

FIG. 448.

Curves.—Plot armature current, and power factor $\left(\frac{\text{watts}}{\text{volt amperes}}\right)$, on an exciting current base.

Questions.—1. Explain the shapes of the curves.

2. What are the advantages and disadvantages of the synchronous motor compared with the induction motor?

3. What effect has the power factor of the load on the size of the alternator and on the power loss in the transmission line supplying the load?

EXPERIMENT 18

Object of Experiment.—To determine the characteristics of a rotary converter.

Reference. Page 318.

Connection.—On the A.C. end the machine is connected in the same way as a synchronous motor, see experiment 17, while on the D.C. end it is connected in the same way as a shunt generator.

Method of Starting.—The machine may be started up as a motor from the D.C. end instead of by means of a starting motor, but it must be synchronized in the same way as a synchronous motor, see experiment 17, before it is connected to the A.C. mains.

Readings.—With the applied voltage E_2 , the frequency, and $E_3 I_3$ the output of the direct current side all constant, take readings of the current I and of the watts W for different values of the exciting current I_f . Take a complete set of readings for $1/4$, $1/2$, $3/4$ and full load output from the direct current side.

Curves.—Plot armature current, and power factor $\left(\frac{\text{watts}}{\text{volts amperes}}\right)$, on an exciting current base.

Plot applied voltage E_2 and direct voltage E_3 on a direct current (I_a) base.

Plot efficiency on a kilowatt output base at 100 per cent. and at some other power factor.

Questions.—1. Answer questions 1 and 3 in experiment 17 if that experiment was not performed.

2. Why is the voltage of the direct current side independent of the field current, and how can this voltage be controlled?

EXPERIMENT 19

Object of Experiment.—To determine the starting and the running characteristics of a polyphase induction motor.

References. Chaps. XXXVI and XXXVII, page 283.

Connections.—The student should draw out a diagram of connections and specify the range of the instruments required.

Readings.—To show the effect of increase in applied voltage on the current, torque and power factor at starting (start with a low value of applied voltage).

Also readings to show the variation of efficiency, power factor, current, and speed with horse-power output, the applied voltage and frequency being normal and constant.

Curves.—Draw the curves necessary to show the characteristics clearly.

Questions.—1. Why is the current for a given torque greater when the motor is at standstill than when running?

2. What are the advantages and disadvantages of the squirrel cage induction motor compared with the wound rotor induction motor?

3. What are the relative advantages and disadvantages of the squirrel cage induction motor and the synchronous motor?

4. Explain the shape of the power factor curve. Why is the power factor low at light loads?

5. Explain the shape of the speed curve.

6. How would you reverse the direction of rotation of an induction motor?

7. How can the speed of an induction motor be varied for a given load? How does the induction motor compare with the direct current shunt motor for the operation of machine tools, and with the direct current series motor for the operation of cranes?

8. What effect has an increase or decrease of applied voltage on the speed of an induction motor at no-load and at full-load? Try this experiment.

EXPERIMENT 20

Object of Experiment.—To determine the voltage and current relations with different transformer connections.

References.—Pages 233 to 238, also Chap. XXXV.

Connections.—*a* Y to Y, Fig. 322, page 276.

b Y to delta

c delta to delta

d Scott connection to obtain two phase from 3 phase.

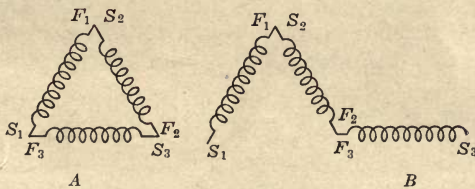

FIG. 449.

Note.—Each transformer should be protected with fuses in case of short circuit. If for example the third transformer in a delta connected bank was connected as in diagram B, Fig. 449, instead of as in diagram A, there would be a large voltage between points S_1 and S_3 , and if they were joined together a very large current would flow through the closed circuit.

Readings.—Measure the voltage per phase, the voltage between lines, the current in each transformer and the current in

the lines, and compare the values obtained with the theoretical values.

Question.—1. What are the advantages and disadvantages of the *Y* and delta connections?

2. Show by experiment that three phase power can be obtained from a delta connected bank if one transformer is removed, but cannot be obtained from a *Y*-connected bank after the removal of one transformer.

INDEX

- Adjustable speed operation, induction motors, 293, 298, 300
 series motors, 92
 shunt motors, 89, 105-112
- Air blast transformers, 271
- Air compressors, drive for, 296
- Air gap, direct current machines, 48, 68
 induction motors, 292
- All day efficiency, 269
- Alternating current, 48, 197
- Alternator, armature reaction of, 244
 characteristics, 244
 construction, 229, 239
 efficiency, 250
 excitation, 240
 inductor type, 241
 magneto, 242
 parallel operation of, 259
 rating, 251
 reactance, 246
 regulation, 245, 248
 revolving armature type 240
 revolving field type 229, 239
 simple, 191
 single-phase, 231
 three-phase, 231
 two-phase, 230
 vector diagram, 245
- Aluminium arrester, 344
- Amalgamation of zinc, 143
- Ammeter, 8, 19, 198
- Ammeter shunt, 368
- Ampere, 5, 18
- Ampere-hour, 18, 33
- Ampere-hour efficiency, 153, 161
- Ampere-turn, 33
- Anode, 139
- Arc lamps, 354, 365
- Arc light generator, 75
- Arc welding generator, 190
- Armature, 49 58,
Armature copper loss, 95
 core, 55
 reaction, 67, 83, 89, 244, 312
 resistance drop, 72, 79
 windings, 48, 230
- Arrester, lightning, 343
- Automatic current regulator, 76
 feeder regulator, 281
 motor starter, 130, 133, 306
 switch, 183
 voltage regulator, 74, 249
- Automobile batteries, 149, 151, 153
 lighting, 186
- Autotransformer, 279, 301
- Average current, 197
- Axle generator, 182
- Back e.m.f., 79, 253, 261, 311
- Balanced load, 238, 316
- Balancer, 316
- Battery capacity, 153, 155, 175
 characteristics, 152, 160
 construction, 148, 158
 control, 171-179
 efficiency, 153, 161
 electromotive force, 141, 142, 151, 161
 primary, 140-145
 resistance, 141, 152, 161
 storage, 146-161
 temperature, 155, 161
- Blow-out coil, 115, 123, 129
- Booster, 173, 176, 180, 315
- Boosting transformer, 281
- Boring mill, motor for, 108
- Brake, 46, 333
- Brake test, 98
- Braking, dynamic, 333
- Brushes, 50, 58
- Brushes, carbon, 66

- Brushes, resistance of, 63, 66
 shifting of, 63, 83
- Bucking field coils, 186
- Building up of voltage, 71
- C.A.V. generator, 189
- Cables, underground, 347
- Candle-power, 354, 365
- Capacity circuits, 218
- Capacity of a battery, 153, 155, 175
- Capacity reactance, 221
- Car lighting, 181
- Carbon battery regulator, 176
 brushes, 66
 incandescent lamp, 352
 lamp regulator, 170, 182
 pile rheostat, 29
 switch contacts, 114
- Cast iron grid resistance, 27
- Cement mill motors, 297
- Characteristics, alternator, 244
 battery, 152, 160
 d.c. generator, 70-77
 d.c. motor, 85-94
 induction motor, 290, 292
 single-phase motor, 310, 311
- Charge of a condenser, 218
- Choke coil, 343
- Circuit, breaker, 39, 117, 170
 formulæ, 223
 magnetic, 33, 46
- Circuits, electric and hydraulic, 18
 parallel and series, 22, 212, 216,
 224, 226
- Circular mil, 20
- Circulating oil method of cooling,
 272
- Clutch, electromagnetic, 46
- Coefficient of adhesion, 323
 of self induction, 206
- Color of light, 362
- Commutation, 62, 68, 83
 limit of output, 100
 of a.c. motors, 314
- Commutator, 50, 58
- Compensating winding, 312
- Compensator, starting, 302
- Compound excitation, 61
 generator, 74, 166
- Compound motor, 93
 starter, 120
- Condensers, 218, 222
- Constant current generator, 75
 regulator, 76
 transformer, 267
- Contact switch, 116, 132
- Contacts, carbon, 114
- Control, of batteries, 171-179
 of railway motors, 126, 133, 327
 multiple unit, 133
 series parallel, 126
- Controllers, 122, 124
 automatic, 130
 crane, 122
 magnetic switch, 131
 master, 132
- Conversion factors, 15
- Converter, mercury vapor, 357
 rotary, 318
- Cooling of machines, 99, 100
 transformers, 270
- Copper losses, 95
- Core depth, 49, 56
 laminations, 55
- Core type transformers, 279
- Corkscrew law, 5
- Cost of motors, 101, 108
- Coulomb, 18
- Coulomb's law, 1
- Counter e.m.f., 79
- Crane motors, 92, 103, 298, 332
- Cross magnetizing effect, 67, 83, 312
- Current, alternating, 48, 197, 212
 direct, 48
 direction of, 4
 effective, 197, 212
 unit, 5
- Current carrying capacity of wires,
 368
- Current transformer, 351
- Cycle, 194
- Dampers, 295
- Daniell cell, 141
- Delta connection, 233, 236, 276, 278,
- Demagnetizing effect, 68, 83
- Dielectric strength, 22
- Differential booster, 176

- Direct current, 48
 Direct current generator, see Generators
 Direction of current, 4
 e.m.f., 9, 11
 force on a conductor, 7
 magnetic field, 2
 Disconnecting switch, 345
 Driving force of a motor, 78
 Drop in armature, 72, 79
 in transmission lines, 23
 Drum type controllers, 124
 windings, 52
 Dry cells, 143
 Dynamic braking, 333

 Eddy current loss, 96, 269
 Edison battery, 157
 Edison Lalande cell, 144
 Effective current, 197, 212
 Efficiency, 97
 alternator, 250
 battery, 152, 161
 direct-current machines, 98
 illuminants, 360
 induction motor, 299
 rotary converter, 320
 transformer, 268
 values of, 98
 Electric furnace, 74
 hammer, 38
 locomotive, 332
 welder, 264
 Electrical degrees, 200
 energy, 14
 power, 14
 Electrodynamometer instruments, 199
 Electrolysis, 139
 Electrolyte, 139, 156, 160
 Electromagnet, 5, 37
 Electromagnetic brakes, 46, 333
 clutches, 46
 induction, 9
 motor, 41
 Electromotive force, back, 79
 direction of, 9, 11
 generation of, 9, 11
 of a battery, 141, 142, 151, 161
 Electromotive force, of self induction, 12,
 unit of, 9
 Elevator motors, 103
 Enclosed arc lamps, 355
 Enclosed machines, 100
 End cell control of batteries, 172
 Energy, chemical and electrical, 140
 heat and electrical, 15
 mechanical and electrical, 14
 required for an electric car, 326
 Equalizer connection, 166
 Ewing's theory of magnetism, 36
 Excitation, 59, 71
 Exciter for alternators, 240
 Exciting current, 60
 External characteristics, 71

 Fan drive, 111, 112, 296, 300
 Farads, 219
 Farm house lighting, 169
 Feeder regulator, 281, 339
 Field copper loss, 95
 Field, magnetic, 1-5, 32
 Field, reversing, 65, 68, 83
 Field rheostat, 74
 Flame arc lamp, 356
 Flashing at switches, 12
 Flat compounding, 75
 Fleming's rule, 9
 Float switch control, 130
 Floating battery, 154, 179
 Flux density, 3, 33, 44
 Flywheel motor generator set, 335
 Flywheel, use of, 94, 104
 Force on a conductor, 6
 Formulæ for circuits, 223
 Frequency, 194, 341
 natural, 226
 of resonance, 226
 Frequency changer, 321
 meter, 195
 Furnace, induction, 263, 267
 Fuses, 117

 Gas-filled lamp, 353
 Gassing of batteries, 147
 Generator, axle driven, 182
 car lighting, 181
 constant current, 75

- Generator, direct-current, armature
 reaction, 67
 characteristics, 71
 commutation, 62, 68
 compound, 74
 construction, 56
 excitation, 60
 limits of output, 100
 parallel operation, 164, 166
 regulation, 71
 series, 75
 shunt, 72
 windings, 48
 induction, 294
 retarding force of, 78
 three-wire, 317
 variable speed, 181
- Glare, 363
 Gramme ring winding, 48
 Grid resistance, 27
 Growth of current, 12
- Hammer, electric, 38
 Head and end system, 181
 Heat and electrical energy, 15
 Heater units, 27
 Heating of machines, 99, 100, 239
 of transformers, 270
 Henry, 207
 Hoist motor, 332
 Hoisting, 332
 Holding magnet, 43
 Horn gap arrester, 345
 switch, 116
 Horse-power, 14
 Horse-power-hour, 15
 Hunting, 258, 295
 Hydrometer, 156
 Hysteresis, 36
 loss, 95, 269
- Ignition, make and break, 206
 Illuminants, efficiency, 360
 Illumination, principles, 362
 intensity, 364
 Incandescent lamps, 352
 Inductance, 205, 209
 adjustable, 210
 of transmission line, 211, 216
- Induction, electromagnetic, 9
 furnace, 263, 267
 generator, 294
 motor, adjustable speed operation, 293, 298
 applications, 296
 characteristics, 291
 construction, 283
 efficiency, 290, 299
 for railway service, 327
 power factor, 293
 single-phase, 308
 slip, 290
 speed, 287, 290, 293
 squirrel cage, 283, 296
 starters, 301-307
 starting torque, 287, 297
 vector diagram, 291
 wound rotor, 288, 297
 mutual, 11
 regulator, 281
 self, 11, 206
- Inductive circuit, 207, 210
 reactance, 208
 Inductor alternator, 241
 Instrument transformers, 351
 Insulating materials, 22, 26, 32, 99
 Insulation of windings, 58
 Insulators, line, 346
 Intensity of illumination, 364
 of magnetic field, 2, 3
 Intermittent ratings, 101
 Internal resistance of a battery, 141,
 152, 161
 Interpole machines, 65, 100
 Ions, 139
 Iron loss, 96
 Iron, magnetic properties, 32
 Ironclad solenoids, 41
 Isolated lighting plants, 169
- Joules, 14
- Kathode, 139
 Kilovolt-amperc, 251
 Kilowatt, 14
 Kilowatt-hour, 15
 Knife switches, 114

- Lagging current, 203, 208
Lamination of armature core, 55
 transformer core, 269
Lamps, arc, 354
 connection of, 365
 incandescent, 352
 mercury vapor, 359
Lamp circuit regulator, 170, 182
Lathes, drive for, 108, 299
Lead battery, 146
Leading current, 203, 221
Leakage reactance of transformers, 264
Leclanché cell, 143
Left hand rule, 7
Lenz's law, 10
Lifting magnets, 43
Light, quality of, 363
 unit of, 354
Lighting of cars and vehicles, 181
 country roads, 363, 364
 drawing offices, 363
 farm houses, 169
 reading rooms, 362
 streets, 360, 364
Lightning arresters, 343
 protection, 346
Limits of output, 100, 255, 291
Line construction, 346
Line shaft drive, 102, 297
Lines of force, 2, 3
Liquid rheostat, 29, 335
Loading back tests, 163
Local action, 143
Locomotive, electric, 332
Long shunt, 61
Losses in alternators, 250
 direct-current machines, 95
 transformers, 268
 transmission lines, 215
Lumens, 364
Luminous arc lamps, 357

Machine tool drive, 108, 299
Magnet, 1
 alternating current, 306
 electro, 5, 37
 lifting, 43
 permanent, 35, 59
 pull of, 40
Magnetic, brakes, 46, 333
 circuit, 33, 46
 clutches, 46
 field, 1-5, 32
 flux density, 3, 33, 44
 hammer, 38
 properties of iron, 32
 separator, 47
 switch controller, 131
Magnetism, molecular theory of, 36
 residual, 35, 70
Magnetization curves, 34, 70
Magnetizing current, induction
 motor, 292
 transformer, 262
Magneto, 59, 242
Magnetomotive force, 34
Make and break ignition, 206
Manganin, 21
Manholes, 347
Master controller, 132
Maximum output of direct-current
 machines, 100
 induction motors, 291
 synchronous motors, 255
Maxwells' formula, 44
Mercury vapor converter, 357
 lamp, 359
Mechanical losses, 95
Mil, circular, 20
Molecular magnets, 36
Motor, direct-current, armature re-
 action, 83, 89
 commutation, 83
 compound, 93
 driving force, 78
 electromagnetic, 41
 limits of output, 100
 railway, 327
 series, 90
 shunt, 85
 speed, 80, 82
 starters for, 87, 117, 130
 theory of operation, 80
 variable speed, 89
 induction, see induction motor
 repulsion, 313
 single-phase induction, 308-310

- Motor, single phase series, 310, 313, 327
 synchronous, see synchronous motor
- Motor applications to air compressors, 296
 boring mills, 108
 cement mills, 297
 cranes, 92, 103, 298, 332
 crushers, 94
 elevators, 103
 fans, 111, 112, 296, 300
 lathes, 108, 299
 line shafts, 102, 297
 machine tools, 108, 300
 printing presses, 111, 113
 pumps, 103, 296
 shears and punch presses, 103, 299
 textile machinery, 298
 wood-working machines, 102, 297
- Motor car lighting, 186
 Motor car trains, 332
 Motor generator sets, 315, 335
 Multiple switch starter, 119, 131, 305
 unit control, 133
 voltage system, 109
- Multipolar machines, 51, 56, 287
 Mutual induction, 11
- Natural frequency, 226
 Neutral line, 62
 No-load saturation curve, 70
 No-voltage release, 87, 125, 302, 304
 Non-arcing metal, 343
 Non-inductive resistance, 211
- Ohm's law, 20
 Oil circulation for transformers, 272
 Oil for transformers, 270
 Oil switch, 300, 345
 Open delta connection, 277
 Open machines, 100
 Oscillograph, 193
 Overcompound generator, 75
 Overhead line construction, 346
- Overload relay on oil switch, 345, 350
 release, 118, 125, 304
- Parallel circuits, 22, 216, 226
 Parallel operation of alternators, 259
 direct-current generators, 164, 166
 rotary converter, 320
- Pasted plates for a battery, 149
 Permanent magnets, 35, 59
 Permeability, 33
 Phase, relation, 203
 single-, two-, and three-, 231
- Pin insulators, 346
 Planté plates, 148
 Polarization, 141
 Polyphase circuits, 238
 rotary converter, 320
- Potential transformer, 351
- Power, 14
 in a capacity circuit, 223
 in an inductive circuit, 209
 in a resistance circuit, 21, 211
 in a three-phase circuit, 236, 237
 measurement of, 214, 238
- Power factor, 213
 correction, 256, 320
 of an induction furnace, 267
 of an induction motor, 293
 of a synchronous motor, 256
 of a transformer, 262
- Power station, 171, 338
 Primary of a transformer, 261
 Printing press drive, 111, 113
 Pull of magnets, 40, 43
 solenoids, 37
- Pump drive, 103, 296
 Punch press drive, 103, 299
 Puncture of insulation, 22
- Quantity of electricity, 18, 218
 Quick break switch, 114, 300
- Railway motors, 327
 Rating of machines, 101, 251
 Ratio of transformation, 262
 of rotary converter, 318

- Reactance, capacity, 221
 inductive, 208
 of an alternator, 246
 of a transformer, 264
 of a transmission line, 211, 216
- Reflectors, 359
- Regulation curves, 71
 of alternators, 245, 248
 of direct-current generators, 71-75
 of a transmission line, 215
 speed, 107, 113, 293
- Regulator, axle generator, 184, 187
 constant current, 76
 feeder, 281, 339
 lamp circuit, 170, 182
 voltage, 74, 249
- Reluctance, 33
- Repulsion motor, 313
- Residual magnetism, 35, 70
- Resistance, 19
 battery internal, 141, 152, 161
 brush contact, 63, 66
 control of batteries, 171
 drop in armature, 72, 79
 for adjustable speed motor, 112, 300
 power loss in, 21, 211
 specific, 20
 starting for motor, 85, 87, 89, 118, 305
 steadying, 365
 temperature coefficient of, 21
- Resistors, 26
- Resonance, 224, 227
- Reverse current circuit breaker, 170
- Reversing drum, 129
- Reversing field, 65, 68, 83
- Revolving field alternator, 192, 229
 • 239
 of an induction motor, 284
- Rheostats, 25
 carbon pile, 29
 cast-iron grid, 27
 field circuit, 74
 liquid, 29, 335
- Right hand rule, 9, 192
- Ring winding, 48
- Rosenberg machine, 188
- Rotary converter, 318
- Rotor, 229
 induction motor, 283, 288
- Safety devices, 337
- Saturation curve, 70
 magnetic, 46, 71
- Scott connection, 274
- Searchlight generator, 190
- Secondary of a transformer, 261
- Self-cooled transformer, 270
- Self excitation, 60, 71
- Self induction, 11, 206
- Self-starting synchronous motor
 294, 296
- Semi-enclosed machines, 100
- Separately excited machines, 60, 71
- Separator, magnetic, 47
- Series arc lighting, 366
 booster, 180
 circuits, 22, 212, 224
 excitation, 60
 generators, 75
 motors, 90, 310
 parallel control, 126
 shunt, 77, 167
- Shades for lamps, 359
- Shadows, 363
- Shears, motor for, 103, 299
- Shell type transformers, 279
- Shifting of brushes, 63, 83
- Short-circuit curve, 246
- Short shunt, 61
- Shunt excitation, 60
 generators, 72, 162, 164
 motors, 85, 105
- Single-phase, 231
 motors, 308-314
 railway system, 329
- Sliding contact starter, 117
- Slip of induction motors, 290, 293
- Slipping belt generator, 185
 clutch generator, 186
- Slow speed drive, 113
- Solenoid, 32, 37, 41
 brake, 333
 starter, 130, 306
- Sparkling, at a commutator, 63

- Sparking, at a switch, 12
 limit of output, 100
 Specific gravity of electrolyte, 156,
 157
 inductive capacity, 219
 resistance, 20
 Speed, adjustable, 89, 92, 105-112,
 293, 298, 300
 Speed of a motor, 80-83, 89, 101
 of an induction motor, 287, 290,
 293, 298
 of a series motor, 92, 312
 of a shunt motor, 89, 105-112
 of a synchronous motor, 252,
 296
 regulation, 107, 113, 293
 regulators, 121
 synchronous, 252
 variation by armature control,
 105, 112
 by field control, 107
 Speed time curve, 323
 Spider, 59
 Split-phase method of starting, 308
 Split-pole rotary converter, 320
 Squirrel-cage motor, 283, 296
 Star-delta starter, 304
 Starters, automatic, 130, 133, 306
 hand-operated, 87, 117-121,
 301-305, 340
 Starting compensator, 302
 Starting torque of an induction
 motor, 287, 297
 of a series motor, 90
 of a shunt motor, 85
 of a synchronous motor, 252,
 294, 296
 Starting resistance, 85, 87, 89, 118,
 305
 Stator, 229, 283
 Steadying resistance, 365
 Stiff field, 69
 Stone generator, 185
 Storage battery, see battery, 146-
 161
 Stray loss, 96
 Street car controller, 126
 Street lighting, 360, 364
 Substation, 339
 Sulphation, 147
 Sum of alternating voltages, 203
 Suspension insulator, 346
 Switches, automatic battery, 183
 carbon break, 114
 contactor, 116, 132
 disconnecting, 345
 float, 130
 magnetic, 131
 oil, 300, 345
 quick-break, 114
 sparkling at, 12
 Switchboards, 348
 Symbols for alternating currents, 198
 Synchronizing, 258, 378
 Synchronous motor, 252-259, 294-
 296
 applications, 296
 dampers for, 295
 hunting, 258, 295
 power factor, 256
 self-starting, 294, 296
 speed, 252, 296
 starting torque, 252, 294, 296
 synchronizing, 258, 378
 vector diagram, 254
 Synchronous speed, 252
 Synchroscope, 258, 350
 Temperature coefficient of resistance,
 21
 of a battery, 155, 161
 of motors, 99, 100, 102
 Terminal station, 339
 Textile mill, drive, 298
 Three-phase alternator, 231
 connection of load, 237
 connection of transformers, 276
 transformers, 279
 Three-wire generators, 317
 system, 316, 338
 Torque of a motor, 82
 of an induction motor, 287, 297
 of a series motor, 90, 310
 of a single-phase motor, 308, 310
 of a shunt motor, 85, 88
 of a synchronous motor, 252,
 294, 296
 Traction, 322-332

- Tractive effort, 322
Train lighting, 181
 friction, 322
Transmission line, drop, 23
 inductance, 211, 216
 insulation, 346
 losses, 215
 regulation, 215
 single- and three-phase, 341
Transmission, underground, 347
 voltages, 338, 341
Transformation ratio, 262
Transformer, boosting, 281
 connections, 273-279, 381
 constant current, 267
 cooling, 270
 efficiency, 268
 instrument, 351
 leakage reactance, 264
 lighting, 273
 losses, 268
 theory of operation, 261
 vector diagram, 263, 265
Trolley wire, 329
Tungsten lamp, 352
Two-phase alternator, 230
 connection of transformers,
 273
Underground cables, 347
Unit of current, 5
 e.m.f., 9
 light, 354
 pole strength, 1
 power, 14
 work, 14
V-connection, 277
Variable speed generators, 182
Variable speed operation, induction
 motors, 293, 298, 300
 series motors, 92
 shunt motors, 89, 105-112
Vector diagram for alternators, 245
 induction motors, 291
Vector diagram for parallel circuit,
 217, 227
 series circuit, 213, 225
 series motor, 311
 synchronous motor, 254
 transformer, 263, 265
 transmission line, 215, 342
Vector sum, 203
Vector representation, 201
Vehicle lighting, 181
Vibrating contact regulator, 187
Volt, 9
Volt efficiency, 152, 161
Voltage, average, 197
 drop in transmission lines, 23
 effective, 212
 for arc lamps, 367
 for traction, 329
 for transmission, 338, 341
 of a battery, 151, 160
 regulators, 74, 249
Voltages used in practice, 341
Voltmeter, 139
Voltmeter, 19, 198
Wagner motor, 314
Ward Leonard system, 110, 335
Water cooled transformers, 271
Water rheostat, 29, 335
Watts, 14
Wattmeter, 214
Wave form, 193
Welder, electric, 264
Windings, 48, 229
Wire, current carrying capacity,
 338, 348, 368
Wood-working machinery, motors
 for, 102, 297
Work, unit of, 14
Wound rotor motor, 288
Y-connection, 233, 235, 237, 276,
 278
Y-delta starter, 304
Yoke of machine, 56, 58

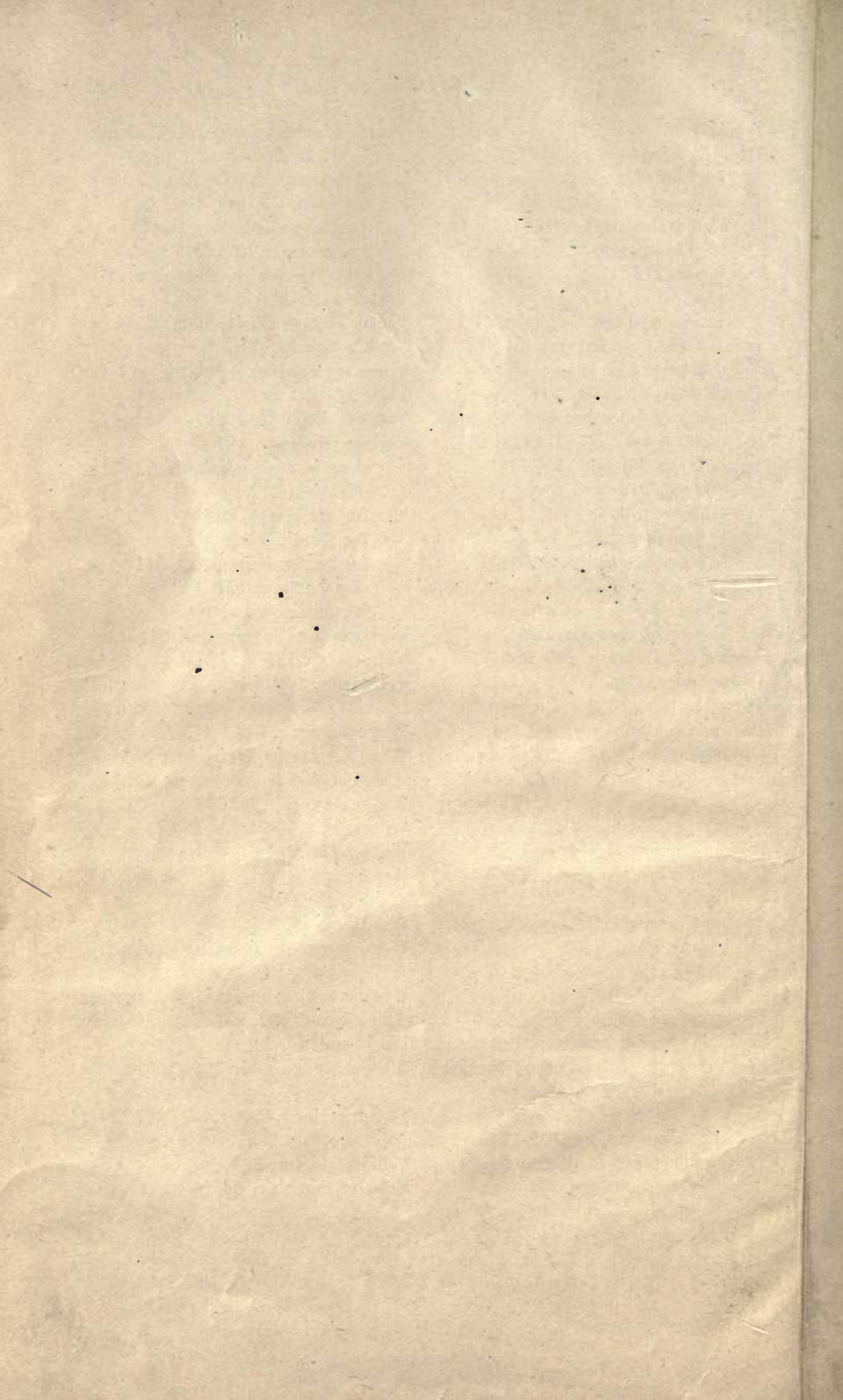

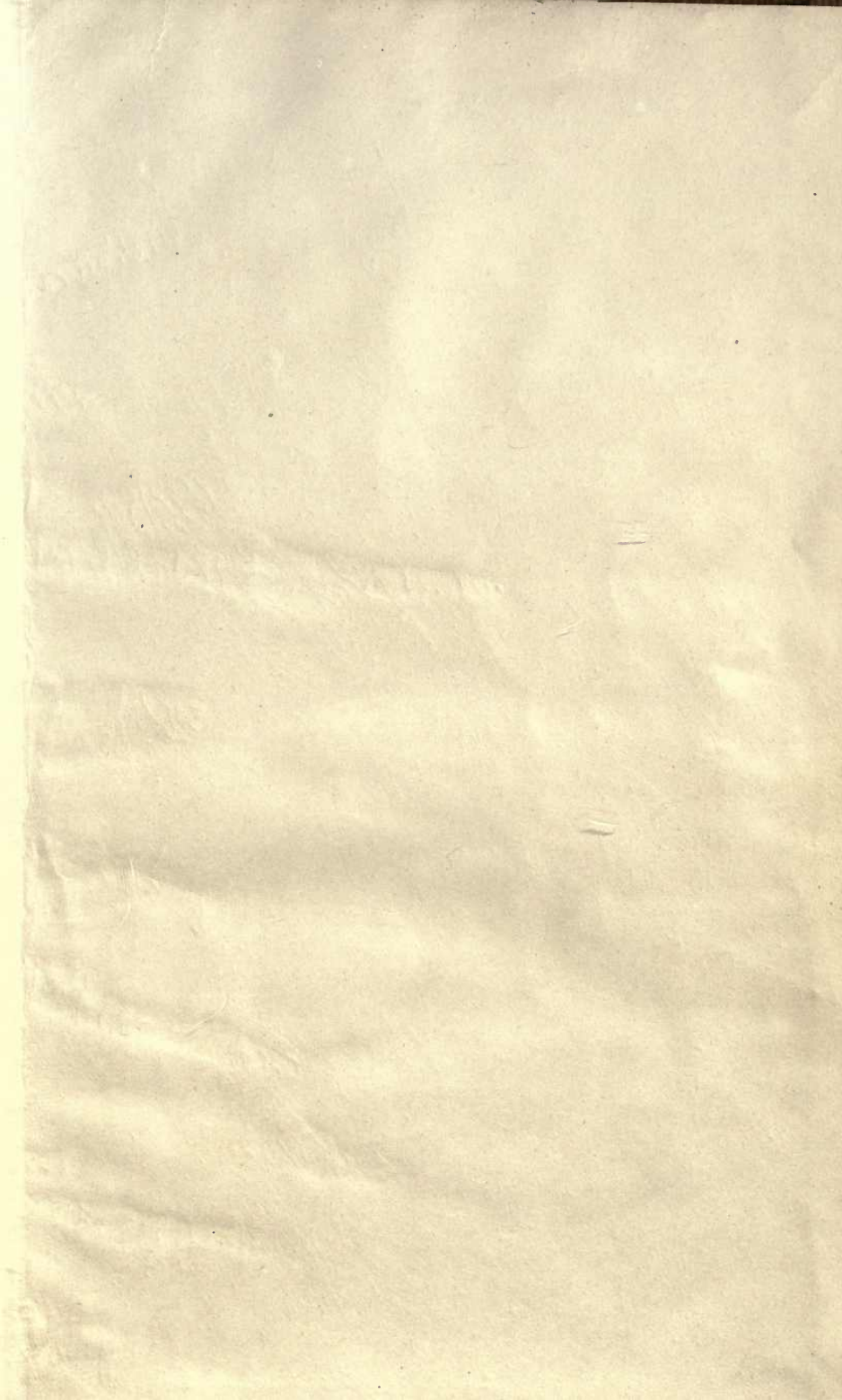

THIS BOOK IS DUE ON THE LAST DATE
STAMPED BELOW

AN INITIAL FINE OF 25 CENTS
WILL BE ASSESSED FOR FAILURE TO RETURN
THIS BOOK ON THE DATE DUE. THE PENALTY
WILL INCREASE TO 50 CENTS ON THE FOURTH
DAY AND TO \$1.00 ON THE SEVENTH DAY
OVERDUE.

ICLT (N)

NOV 27 1940

MAR 9 1943

DEC 12 1940 M

FEB 14 1944

NOV 4 1946

DEC 17 1940

28 Aug 51 RF

27 Aug 51 LU

FEB 22 1941 M

14 Oct '58 WW

MAR 13 1941 M

REC'D LD

SEP 30 1958

MAR 27 1941

APR 10 1941 M

AUG 8 1967 94

FEB 12 1942

AUG 11 '67 - 1 PM

LD 21-100m-7,'40 (6936s)

YC 19562

294683

TK145

97

UNIVERSITY OF CALIFORNIA LIBRARY

