

EX LIBRIS

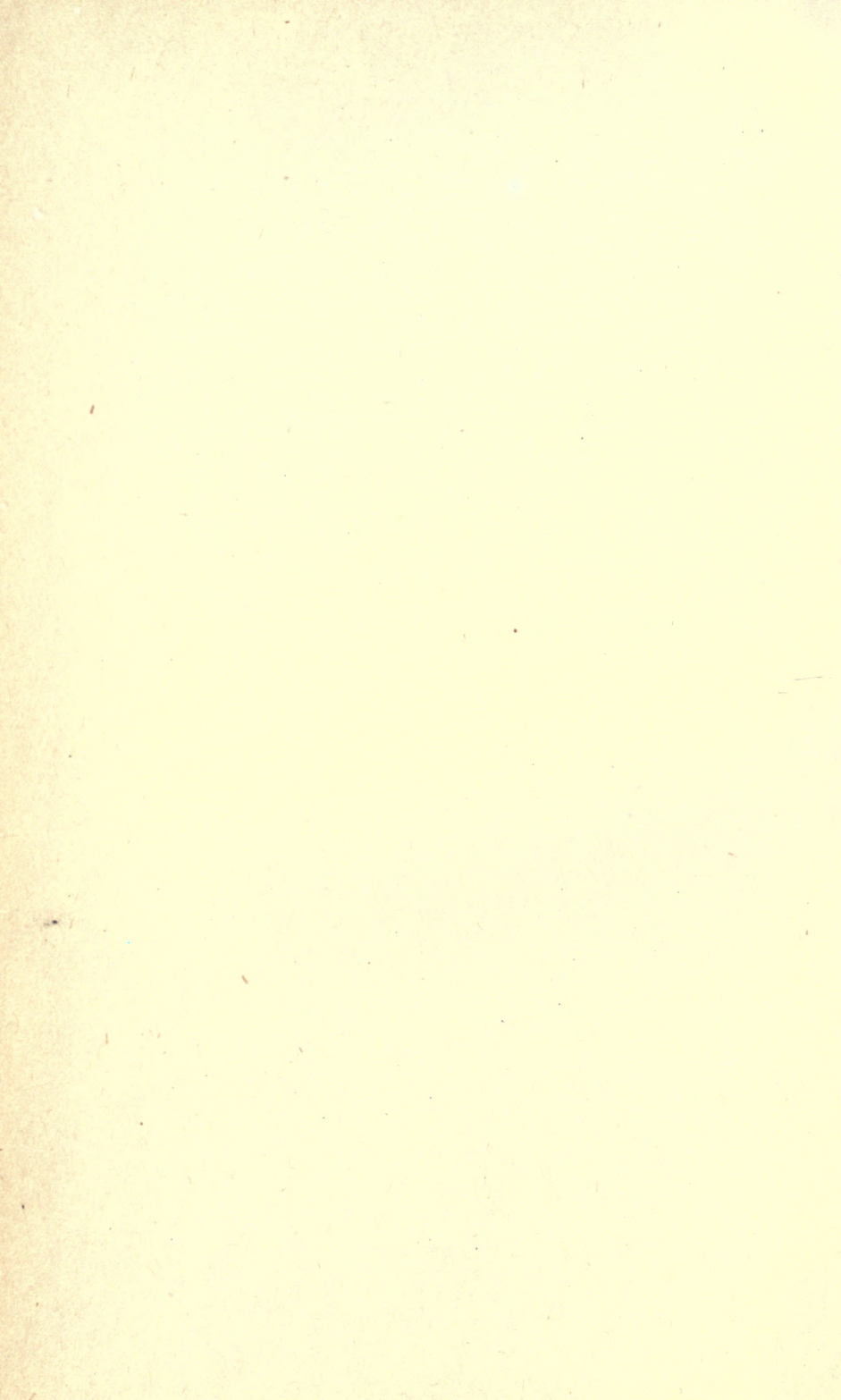

ELECTRICAL ENGINEERING
ADVANCED COURSE

McGraw-Hill Book Company

Publishers of Books for

Electrical World	The Engineering and Mining Journal
Engineering Record	Engineering News
Railway Age Gazette	American Machinist
Signal Engineer	American Engineer
Electric Railway Journal	Coal Age
Metallurgical and Chemical Engineering	Power

ELECTRICAL ENGINEERING

ADVANCED COURSE

BY

ERNST JULIUS BERG Sc. D.

PROFESSOR OF ELECTRICAL ENGINEERING UNION
COLLEGE, SCHENECTADY, N. Y.

AUTHOR OF "ELECTRICAL ENGINEERING," FIRST COURSE

UNIV OF
CALIFORNIA

FIRST EDITION

McGRAW-HILL BOOK COMPANY, INC.
239 WEST 39TH STREET. NEW YORK

LONDON: HILL PUBLISHING CO., LTD.

6 & 8 BOUVERIE ST., E. C.

1916

TK145
B45

COPYRIGHT, 1916, BY THE
MCGRAW-HILL BOOK COMPANY, INC.

TO VIM
ABROAD

THE MAPLE PRESS YORK PA

PREFACE

This volume contains abstracts of a series of lectures given to graduate students in electrical engineering at Union College. It is primarily intended to prepare the student to understand and to deal mathematically with phenomena which are incidental to abnormal or transient conditions in electric circuits.

The first part is practically a reprint of a series of articles published by the author some years ago in the *General Electric Review*. These cover the simple transients in circuits containing concentrated inductance, capacity, and resistance, which have been treated by many authors, notably by BEDELL AND CREHORE in their "Alternating Currents," published 1893.

The second part deals with the somewhat more difficult problems of transients in circuits of distributed inductance, capacity and resistance. These were treated mathematically very fully almost thirty years ago by Heaviside in a series of papers on "Electromagnetic Theory," later published in book form. In 1909 Steinmetz's "Transient Phenomena" appeared. This book covered in a broad sense very much the same ground as that of the authors given above, but covered it in an essentially different way; introducing for the first time—as far as the author knows—a really advanced book on practical electrical engineering problems.

The third part of the book deals with problems in electrostatics. These again have been very fully treated almost fifty years ago by Maxwell in his famous books on "Electricity and Magnetism." Since that time a large number of papers and books have appeared on the subject, notably by Heaviside, Kelvin, Gray, Jeans and Webster, and quite recently by Coffin in his interesting little book on "Vector Analysis."

While the literature on this phase of engineering is thus very extensive, it has, for all purposes, been closed to the practical engineer because of his lack of sufficient mathematical knowledge. Dr. W. S. Franklin has, however, recently published a number of papers, which in a beautifully simple way have demonstrated that these advanced problems can be solved with simple mathematics.

The last part of the book gives an outline of the theory of electric radiation. The mathematical theory was again given almost fifty years ago by Maxwell. Hertz's verification of Maxwell's theoretical work given twenty years later and published in his "Electric Waves" is today almost the last word in the theory of wireless transmission of energy. Yet it would be out of place to omit a reference to the recent excellent papers and books by Marconi, Lodge, Flemming, Pierce, Zenneck, Cohen, Austin and a score of others.

It is evident then that the field covered in this volume is not new. Nevertheless, the book seems justified because it endeavors to give the theory in a way comprehensible to students who have had only the ordinary undergraduate course in electrical engineering. It is hoped that the volume will also serve a useful purpose in bringing to the attention of students a field of mathematics of extreme practical importance that is hardly known to them.

The author is greatly indebted to one of his graduate students, MR. M. K. TSEN, who not only examined the manuscript in detail, but checked and elaborated upon the theoretical work. He is also indebted to DR. A. S. McALLISTER, who kindly criticized the manuscript prior to its publication and offered valuable suggestions.

CONTENTS

CHAPTER	PAGE
INTRODUCTION	1

PART I

TRANSIENT PHENOMENA

I.	CIRCUITS CONTAINING CONCENTRATED INDUCTANCE AND RESISTANCE.	3
II.	PROBLEMS INVOLVING MUTUAL INDUCTANCE.	33
III.	CIRCUITS OF RESISTANCE AND VARIABLE INDUCTANCE	56
IV.	CHARACTERISTICS OF CONDENSERS	68
V.	A CIRCUIT CONTAINING DISTRIBUTED RESISTANCE AND INDUCTANCE	106
VI.	CIRCUIT CONTAINING DISTRIBUTED LEAKAGE—CONDUCTANCE AND CAPACITY.	110
VII.	CIRCUIT CONTAINING DISTRIBUTED RESISTANCE AND CAPACITY.	113
VIII.	DISTRIBUTED INDUCTANCE AND CAPACITY.	127
IX.	DISTRIBUTED RESISTANCE—INDUCTANCE—LEAKAGE—CONDUCTANCE AND CAPACITY	143
X.	PERMANENT CONDITIONS WHEN ONE OF THE FOUR CONSTANTS, R, L, G, AND C IS NEGLIGIBLE	148
XI.	DISTRIBUTION OF FLUX OR CURRENT IN A CYLINDRICAL OR FLAT CONDUCTOR	150

PART II

PROBLEMS IN ELECTRO-STATICS

XII.	FUNDAMENTAL LAWS.	157
XIII.	METHODS OF IMAGES, APPLIED TO THE PROBLEM OF POINT CHARGES + 10 AND - 5, SEPARATED 5 CM.	168
XIV.	APPLICATION OF THE POTENTIAL FORMULA $V = \sum_r^m$ TO SOME MAGNETIC PROBLEMS	180
XV.	DIVERGENCE OF A VECTOR, POISSON AND LAPLACE EQUATIONS. 186	186
XVI.	LEGENDRE'S FUNCTION	189
XVII.	DISTRIBUTION OF CHARGE ON AN ELLIPSOID.	199
XVIII.	CONCENTRIC SPHERES	209
XIX.	CYLINDRICAL CONDUCTORS	218
XX.	MUTUAL AND SELF-INDUCTION OF ELECTRO-STATIC CHARGES OR FLUXES—MAXWELL'S COEFFICIENTS	232
XXI.	TWO-CONDUCTOR CABLE	237

XXII.	THE ELECTRO-STATIC EFFECT OF A THREE-PHASE LINE ON AN ADJACENT WIRE OR WIRES	249
XXIII.	THE CURL OF A VECTOR	257
XXIV.	THE EQUATION OF THE ELECTROMOTIVE FORCE	260
XXV.	SOLUTION OF ALTERNATING CURRENT IN CYLINDRICAL CON- DUCTOR—SKIN EFFECT	271
XXVI.	ELECTROMAGNETIC RADIATION.	278
APPENDIX I:	PARTIAL DIFFERENTIATION	319
APPENDIX II:	ELEMENTS OF VECTOR ANALYSIS.	327
INDEX		331

ELECTRICAL ENGINEERING ADVANCED COURSE

PART I. TRANSIENT PHENOMENA

CHAPTER I

CIRCUITS CONTAINING CONCENTRATED INDUCTANCE AND RESISTANCE

The study of transients in circuits of concentrated inductance and resistance involves as a rule a knowledge of the solution of linear differential equations of the first order.

One example of such a differential equation is:

$$\frac{dy}{dx} + f_1(x)y = f_2(x) \quad (1)$$

where $f_1(x)$ and $f_2(x)$ may be functions of x or constants, but must not be functions of y .

For the sake of convenience $f_1(x)$ will be denoted by P and $f_2(x)$ by Q . P and Q in the most general case are then functions of x but not of y . Thus, equation (1) becomes

$$\frac{dy}{dx} + Pdy = Q \quad (2)$$

A solution of this equation can be obtained, in several ways, all of which, however, involve "educated guesses."

Let, for instance,

$$y = uv \quad (3)$$

where u and v are unknown functions of x , which will be determined in the most advantageous way.

Since

$$y = uv, \quad \frac{dy}{dx} = u \frac{dv}{dx} + v \frac{du}{dx} \quad (4)$$

Substituting (3) and (4) in equation (2),

$$\therefore u \frac{dv}{dx} + v \frac{du}{dx} + Puv = Q,$$

or

$$v \left(\frac{du}{dx} + Pu \right) + u \frac{dv}{dx} = Q \quad (5)$$

Since u is entirely arbitrary, this expression can be greatly

simplified, by selecting such a value of u as to make the coefficient of v or the parenthesis zero. Therefore let:

$$\frac{du}{dx} + Pu = 0, \text{ or } \frac{du}{u} = -Pdx.$$

$$\therefore \log u = -\int Pdx + C.$$

Since the simplest possible function is sought, let that particular one be chosen, which makes $C = \text{zero}$. Thus:

$$\log u = -\int Pdx,$$

and

$$u = \epsilon^{-\int Pdx} \quad (6)$$

Substituting now this value in (5), there is obtained,

$$\epsilon^{-\int Pdx} \frac{dv}{dx} = Q, \text{ or } \frac{dv}{dx} = Q\epsilon^{\int Pdx}.$$

$$\therefore v = \int \epsilon^{\int Pdx} Qdx + C.$$

and since

$$y = \epsilon^{-\int Pdx} [\int \epsilon^{\int Pdx} Qdx + C] \quad (7)$$

Special cases:

First.—Let P be constant, a ; and Q be a function of x

$$\therefore \frac{dy}{dx} + ay = Q,$$

and

$$y = \epsilon^{-ax} [\int \epsilon^{ax} Qdx + C] \quad (8)$$

Second.—Let P be a function of x , but Q be a constant, b .

$$\therefore \frac{dx}{dy} + Py = b$$

and

$$y = \epsilon^{-\int Pdx} [b \int \epsilon^{\int Pdx} dx + C] \quad (9)$$

Third.—Let both P and Q be constants, a and b respectively,

$$\therefore \frac{dy}{dx} + ay = b,$$

and,

$$y = \epsilon^{-ax} \left[\frac{b}{a} \epsilon^{ax} + C \right],$$

or,

$$y = \frac{b}{a} + C\epsilon^{-ax} \quad (10)$$

Fourth.—Let P be a function of x and Q be zero.

$$\therefore \frac{dy}{dx} + ay = 0,$$

and,

$$y = \epsilon^{-\int Pdx + C_1} = C\epsilon^{-\int Pdx} \quad (11)$$

If P is a constant a , then $y = C\epsilon^{-ax}$.

Fifth.—Let P be zero and Q be a constant, b ,

$$\therefore \frac{dy}{dx} = b,$$

and,
$$y = bx + C. \tag{12}$$

Two useful integrals that can, of course, easily be solved but will frequently appear are given below for the sake of convenience.

$$\int \epsilon^{\alpha t} \cos \omega t \, dt = \frac{\epsilon^{\alpha t}}{\alpha^2 + \omega^2} [\omega \sin \omega t + \alpha \cos \omega t].$$

$$\int \epsilon^{\alpha t} \sin \omega t \, dt = \frac{\epsilon^{\alpha t}}{\alpha^2 + \omega^2} [\alpha \sin \omega t - \omega \cos \omega t].$$

A study will now be made of the equation of the current flowing in such circuit when the impressed e.m.f. is steady and also when it varies with time. Referring to Fig. 1, it is evident that the following e.m.fs. exist:

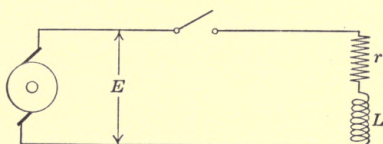

FIG. 1.

First, the impressed e.m.f., E ;

Second, the e.m.f. consumed by the resistance = ir ;

Third the e.m.f. consumed by the self-inductance = $\frac{N}{10^8} \frac{d\phi}{dt}$ or $L \frac{di}{dt}$;

where E is the impressed e.m.f. in volts,

r the resistance in ohms,

N the number of turns of the coil,

L the inductance in henrys (assumed constant),

$\frac{d\phi}{dt}$ the rate of change of flux at a particular instant, t , and

i the current in amperes at any particular instant.

The e.m.f. consumed by self-inductance can be expressed as $\frac{Nd\phi}{10^8 dt}$ or $L \frac{di}{dt}$ because the inductance by definition is:

$$L = \frac{N\phi}{10^8 i}$$

thus

$$\frac{Nd\phi}{10^8 dt} = L \frac{di}{dt}$$

The equation connecting these e.m.fs. is obviously:

$$E = ir + \frac{N}{10^8} \frac{d\phi}{dt} \quad (13)$$

or,

$$E = ir + L \frac{di}{dt} \quad (14)$$

That is, at any instant the impressed e.m.f. E is numerically equal to the e.m.f. consumed by the resistance and the e.m.f. consumed by the inductance. Note that e.m.fs. *consumed* by but not e.m.fs. of resistance and self-induction are considered. The latter are:

$$-ir \text{ and } -L \frac{di}{dt}$$

Equation (14) can be written:

$$\frac{di}{dt} + \frac{r}{L} i = \frac{E}{L} \quad (15)$$

Compare this equation with (2) and note that $P = \frac{r}{L}$ and $Q = \frac{E}{L}$ are constant when the impressed e.m.f. is constant and not function of t . Thus the solution is found in equation (10) and is:

$$i = C\epsilon^{-\frac{r}{L}t} + \frac{E}{r} \quad (16)$$

The integration constant C is determined from the fact that time is required to impart energy, that is, in this case to produce or alter a magnetic field.

Before the switch is closed, there is obviously no field surrounding the turns. Shortly after, however, there is a current and thus a field which appears simultaneously with the current.

Thus since a magnetic field can not be produced instantaneously, no current can pass at the very first instant. Thus for $t = 0$, $i = 0$. Therefore

$$0 = C\epsilon^{-\frac{r}{L}0} + \frac{E}{r},$$

but

$$\epsilon^0 = 1,$$

therefore

$$O = C + \frac{E}{r}, \text{ and } C = -\frac{E}{r};$$

and

$$i = \frac{E}{r} \left(1 - \epsilon^{-\frac{r}{L}t} \right) \tag{17}$$

This equation shows, that as t increases, the current increases, and finally reaches a value,

$$i_f = I = \frac{E}{r}.$$

Assume now that after the current has reached this value, the circuit is disconnected from the generator, and at the same instant short-circuited. What can be expected to happen?

The Dying Away of a Current in an Inductive Circuit.—Referring to Fig. 2, since the coil is surrounded by a magnetic field, and the field can not be destroyed instantaneously, and since the magnetic field can not exist without a current, it is evident that the current can not disappear instantaneously, but must die away gradually.

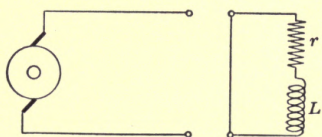

FIG. 2.

Referring to equation (15) which is the general equation of the current and remembering that the impressed e.m.f. E is zero, we have:

$$\frac{di}{dt} + \frac{r}{L} i = 0$$

the solution of which has been shown to be:

$$i = C \epsilon^{-\frac{r}{L}t}.$$

To determine the integration constant, it is remembered that at the very first instant when $t = 0$, there was a definite current I in the circuit.

Thus,

$$i = I \text{ when } t = 0,$$

which substituted above gives:

$$C = I,$$

and the equation of the decaying current becomes:

$$i = I \epsilon^{-\frac{r}{L}t} \tag{18}$$

If dW is the energy delivered during a short interval dt , then the rate of energy supply, or power is:

$$P = \frac{dW}{dt}$$

The practical unit of power is the watt, which is work done at the rate of 1 joule per second. At any instant the power is the product of the instantaneous values of e.m.f. and current.

Thus the power equation corresponding to equation (14) is:

$$\begin{aligned} Ei &= i \times ir + i \times L \frac{di}{dt} \\ &= i^2r + Li \frac{di}{dt} \end{aligned} \quad (19)$$

It is seen from this equation that when the instantaneous value of the current is i , energy is being dissipated at the rate of i^2r joules per sec., or watts, in heat, and is being stored in the magnetic field at the rate of $Li \frac{di}{dt}$ watts. The energy that has been supplied to the circuit t sec. after the switch is closed and the current started is:

$$\int_0^t E i dt \quad \text{joules} \quad (20)$$

The energy dissipated in heat

$$= \int_0^t i^2 r dt \quad (21)$$

and the energy stored in the magnetic field

$$= \int_0^t Li \frac{di}{dt} dt = L \int_0^t i di = L \frac{I_0^2}{2} \quad (22)$$

where I_0 is the particular value of i when the time is t .

In almost all calculations of transient phenomena, the expression ϵ^{-ax} is met with. ϵ is the base of the natural logarithm. It has the numerical value of approximately 2.718. To calculate the numerical value of any particular expression, the ordinary logarithms are used. Thus, for instance, to find the value of $y = \epsilon^{-0.2}$, the method is as follows:

$$\begin{aligned} \log y &= -0.2 \log \epsilon = -0.2 \times 0.434 = -0.0868 \\ &= +0.9132 - 1, \end{aligned}$$

therefore $y = 0.819$,

therefore $\epsilon^{-0.2} = 0.819$.

In Fig. 3 are shown the values of this function for a large number of values of the exponents. Since this curve is plotted on rectangular coördinate paper, it is rather unsatisfactory for small values of the exponent, and the table below has therefore been worked out.

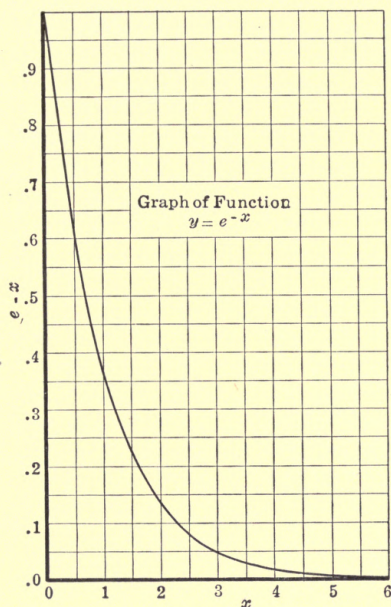

FIG. 3.

x	e^{-x}	x	e^{-x}	x	e^{-x}	x	e^{-x}
0.00	1.0	0.25	0.78	0.80	0.449	1.8	0.165
0.02	0.98	0.30	0.741	0.85	0.427	2.0	0.135
0.04	0.96	0.35	0.705	0.90	0.407	2.5	0.084
0.06	0.942	0.40	0.67	0.95	0.387	3.0	0.05
0.08	0.923	0.45	0.638	1.0	0.368	4.0	0.018
0.10	0.905	0.50	0.607	1.1	0.333	5.0	0.0067
0.12	0.887	0.55	0.577	1.2	0.301	6.0	0.0025
0.14	0.870	0.60	0.549	1.3	0.273	7.0	0.0009
0.16	0.852	0.65	0.522	1.4	0.247	8.0	0.00034
0.18	0.835	0.70	0.497	1.5	0.202	9.0	0.00012
0.20	0.819	0.75	0.472	1.8	0.165	10.0	0.00004

Example No. 1.—A coil having 1000 turns and 5 ohms resistance is connected to a source of constant potential of 100 volts.

(a) Show at what rate energy is being delivered to the entire circuit and to the resistance. Show at what rate it is being stored in the magnetic field as the current is increasing after the circuit is closed.

(b) What is the rate of change of the flux when the current is 10 amp.?

Referring to equation (13),

$$E = ir + \frac{N}{10^8} \frac{d\phi}{dt} \quad (23)$$

therefore the rate of energy supply to the entire system is Ei watts,

and

$$Ei = i^2r + \frac{Ni}{10^8} \frac{d\phi}{dt} \quad (24)$$

The current will begin at zero value and finally reach a value of

$$i = I = \frac{E}{r} = 20 \text{ amp.}$$

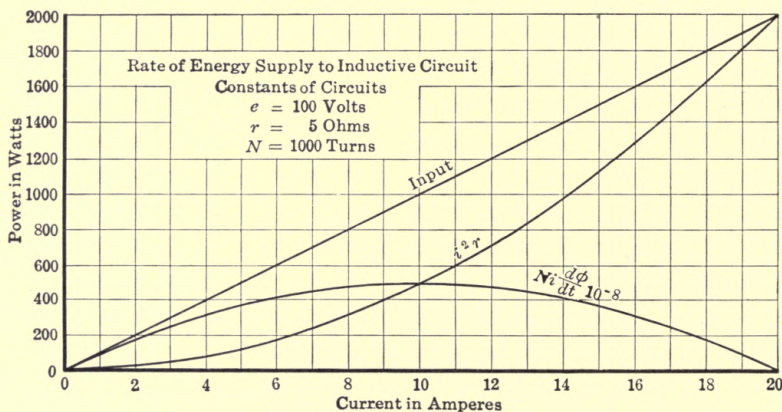

FIG. 4.

The rate at which energy is dissipated in heat is i^2r and the rate at which energy is stored in the magnetic field is:

$$\frac{Ni}{10^8} \frac{d\phi}{dt} = Ei - i^2r \quad (25)$$

The three curves in Fig. 4 show these rates.

It is interesting to note that energy is being stored at the greatest rate when the current is one-half of the the final value. This can readily be proven by differentiation of equation (25) and equating the result to zero, thus,

$$E - 2ir = 0,$$

therefore

$$i = \frac{E}{2r} = \frac{I}{2}.$$

The rate of change of the flux as the current changes is obviously

$$\frac{d\phi}{dt} = \frac{E - ir}{N \times 11^{-8}}.$$

Therefore when the current is 10 amp. the rate of change is 5,000,000 lines per sec. The rate of change is greatest at first and becomes zero when the current reaches its final value.

The determination by calculation of the inductance L of a circuit is usually very difficult, in fact almost impossible except in the very simplest cases, such as parallel long circular conductors. Approximations of one nature or another have almost always to be resorted to. Usually the inductive circuit contains iron, and in that case the reluctance (and hence the inductance) is not constant but changes with the degree of magnetization. Later in this volume the effect of the changing inductance in iron circuits will be considered, but at present it shall be assumed that L is a constant regardless of the value of the current.

The inductance of the field circuit of a dynamo can readily be determined for any particular field current by experiment. All that is needed is to run the machine at some speed and to read the voltage and field current. These data in addition to those of the field and armature windings suffice. By definition,

$$L = \frac{\text{total flux} \times \text{turns}}{\text{current} \times 10^8} \quad (26)$$

The total flux per pole is determined from the voltage, speed and armature winding. Consider a 10-kw., two-pole, direct-current, 110-volt generator, having 2.5 megalines of flux per pole, and 1500 field-turns per pole. Assume that at normal voltage its field current is 3 amp. and that the field spools are connected in series. Thus

$$L = \frac{2.5 \times 10^6 \times 1500 \times 2}{3 \times 10^8} = 25 \text{ henrys.}$$

Example No. 2.—Figs. 5 and 6 represent the direct-current generator referred to above. M is the armature and F the field. If a voltmeter of 11,000 ohms resistance is connected as shown and switch S is opened without arc when the field current in ammeter A is 3 amp., what will be the effect on the voltmeter and will the ammeter and voltmeter read in the same direction as

before the switch was opened? Before the switch is opened the current flow is as shown in Fig. 5. As the switch is opened the field flux can not die away instantaneously. The field current therefore can not die away instantaneously, but continues to flow through the only available path, which is that of the voltmeter. Since the resistance of the voltmeter is 11,000 ohms it is evident that the voltage across the instrument becomes at the very first instant very high.

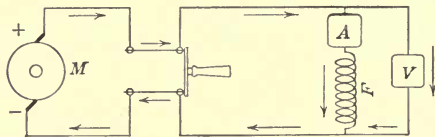

FIG. 5.

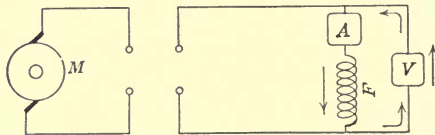

FIG. 6.

It tends to become $ir = 3 \times 11,000 = 33,000$ volts.

Thus the voltmeter will probably burn out as the needle swings to the opposite side of the scale. The ammeter needle will remain stationary for the first instant and gradually come down to zero.

This problem gives an idea of the nature of the shock that is experienced where the field current of a generator is carelessly interrupted and permitted to pass through a person. Depending upon the nature of the contact the resistance of a body may be from 1000 to 10,000 ohms. If, therefore, a person touches both sides of the field winding when the field circuit is interrupted, he will experience a very severe shock. The energy stored is usually quite considerable. In this case it is $\frac{1}{2}LI^2 = \frac{1}{2} \times 25 \times 9 = 113$ joules. Since 1 joule is 0.74 ft.-lb., the energy available is 84 ft.-lb., *i.e.*, that of a pound weight dropping 84 ft.

It may be asked, what would happen if the voltmeter were not connected across the field winding? Where would the initial rush of current, of 3 amp. flow, when the switch was opened?

In reality it is impossible to open the field switch without an arc; therefore the current can not be interrupted instantaneously.

Furthermore the circuit is more complex than assumed. The field winding has considerable capacity and therefore acts as if it were shunted by a condenser. A portion of the 3 amp. will therefore flow as condenser current, but a large portion will appear as secondary currents in the iron circuit of the poles. This phenomenon will be understood later from the investigation of circuits having mutual inductance.

The problem is instructive in that it explains frequent burnout of voltmeters, and in that it teaches that the voltmeter should always be disconnected before the switch is opened, or otherwise be connected on the armature side of the field switch. It teaches also that in opening the field switch a relatively low resistance should be shunted across the field winding to prevent high voltage, and finally that it is well to open the field switch slowly. The importance of shunting the field circuit is best illustrated by a numerical example.

Example No. 3 (Fig. 7).—Assume that the field circuit having a resistance of 36.5 ohms is shunted by a resistance of 50 ohms, and assume again, for the sake of simplicity, that the field current of

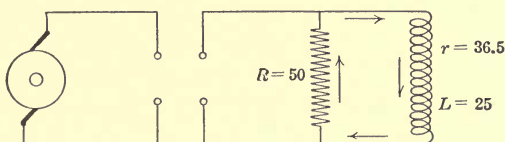

FIG. 7.

3 amp. is interrupted without arc and that L is constant at 25 henrys. The total resistance in the circuit is then $50 + 36.5$ ohms or 86.5 ohms. Determine the current in the field winding and the shunted resistance and the voltage across the field coils which is the same as the voltage across the resistance after the switch is opened.

Referring to equation (18)

$$i = Ie^{-\frac{rt}{L}} = 3e^{-3.46t}.$$

For t	0	0.05	0.10	0.20	0.5	1.0
$e^{-3.46t}$	1	0.84	0.71	0.50	0.18	0.03
i	3	2.32	2.13	1.5	0.54	0.09
iR	150	116.0	107.0	75.0	27.0	3.0

It is seen that in this case the maximum voltage across the field coils, which, of course, occurs at the moment of opening the switch, is 150 volts, as compared with 33,000 when the voltmeter shunted the field coils. The field current i dies away very rapidly. In 1 sec. it has almost disappeared. The energy stored in the field is spent in heating as an i^2r loss.

Example No. 4.—Prove that in discharging an inductive circuit all energy stored is spent in heat.

The instantaneous value of the current was found to be:

$$i = I\epsilon^{-\frac{r}{L}t},$$

therefore the energy expended in heat from time zero to infinite time is:

$$\begin{aligned} \int_{t=0}^{t=\infty} i^2 r dt &= I^2 r \int_0^{\infty} \epsilon^{-\frac{2r}{L}t} dt \\ &= I^2 r \left[-\frac{L}{2r} \epsilon^{-\frac{2r}{L}t} \right]_0^{\infty} = -L \frac{I^2 r}{2r} (0 - 1) = \frac{1}{2} LI^2. \end{aligned}$$

It is of interest to study the rate at which the field flux, or what is equivalent, the field current, can build up when closing the field winding on a constant-potential busbar, and to see how much more rapidly the field current can be made to build up when a considerable resistance is inserted in series with the field coils.

It will be assumed that use is made of the winding described in example 3, that is, one with a resistance of 36.5 ohms and inductance of 25 henrys. This circuit is connected to a direct-current busbar having a constant potential of 110 volts. Referring to equation (17),

$$i = \frac{E}{r} \left[1 - \epsilon^{-\frac{r}{L}t} \right] = 3 \left[1 - \epsilon^{-1.46t} \right].$$

The lower curve in Fig. 8 shows the result of this calculation.

If, instead of exciting the winding from a 110-volt main, it is connected to a 220-volt circuit and sufficient resistance is inserted in series to keep the permanent current at 3 amp., the rise in current will be more rapid than in the first case, as shown in the upper curve of Fig. 8.

There is an interesting mechanical analogy for the starting or stopping of a current in an inductive circuit.

To bring a train up to speed a certain force is necessary; this force must overcome the friction and provide the necessary acceleration.

Let F be the total force necessary, and fv the force of friction and wind resistance which, for simplicity's sake, is assumed to be proportional to the velocity v , and the mass M .

Then $F = fv + \text{mass} \times \text{acceleration}$

$$= fv + M \frac{dv}{dt},$$

or,
$$\frac{dv}{dt} + \frac{f}{M}v = \frac{F}{M}.$$

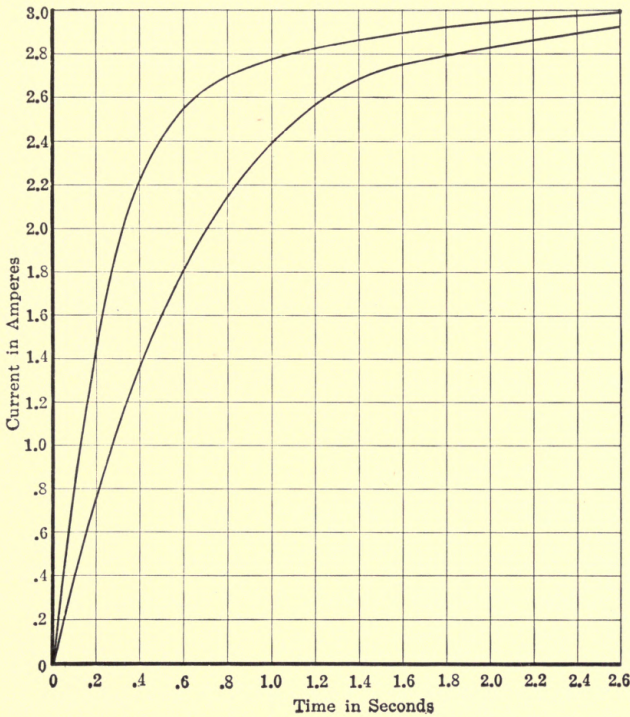

FIG. 8.

If the drawbar pull F as well as the coefficient of friction f be assumed constant during acceleration,

$$v = \frac{F}{f} + C\epsilon^{-\frac{f}{M}t},$$

where C is the integration constant.

If the train start from rest, then for $t = 0$, $v = 0$.

$$\therefore O = \frac{F}{f} + C, \text{ or, } C = -\frac{F}{f},$$

or,

$$v = \frac{F}{f} \left[1 - e^{-\frac{f}{M}t} \right].$$

By comparing this with the equation for the starting of a current in an inductive circuit, which is, $i = \frac{E}{r} \left[1 - e^{-\frac{r}{L}t} \right]$, it is seen that in electrical problems, the current corresponds to velocity, the e.m.f. to the mechanical force, the ohmic resistance to frictional resistance and the inductance to the mass.

The analogy can be carried further. The energy stored in the magnetic field, $\frac{1}{2}LI^2$, corresponds to the kinetic energy of a moving body, $\frac{1}{2}Mv^2$. The electromagnetic momentum LI corresponds to the mechanical momentum Mv , etc.

A problem involving mechanical as well as electrical transients will next be considered.

Find the equation of the dying away of the field current in a direct-current self-excited shunt motor disconnected from the circuit and permitted to decelerate to standstill.

Let the moment of inertia of the revolving part be I . Let the full speed be N revolutions per second corresponding to an angular velocity of α_0 radians per second. Let the power required to run the motor at full speed but at no-load be P hp., and assume that this power is represented by friction loss in the brushes and bearings, which is a very close approximation, particularly after a few seconds of deceleration, when the core loss becomes very small; and neglect the i^2r loss. Assume that the saturation curve is a straight line, so that proportionality exists between the field current and the flux.

Let the normal field current be I_0 . Let the normal flux per pole corresponding to this current be Φ . Let the armature e.m.f. at full speed and flux be E , and the total field-circuit resistance be r , and let the motor have p poles and each field spool have n turns.

Mechanical Calculations.—1. Determine the angular velocity α_0 . It is, $\alpha_0 = 2\pi N$.

2. Determine the friction torque, or moment Q . We have

$$P = \frac{2\pi RN \times \text{lb.}}{550},$$

or
$$Q = R \times \text{lb.} = \frac{550P}{2\pi N} = \frac{550P}{\alpha_0}.$$

3. Determine the stored energy. In general $W = \frac{1}{2}Mv^2$, in the case of a revolving wheel; if ρ is the radius of gyration,

$$W = \frac{1}{2}M(2\pi\rho N)^2 = \frac{1}{2}I\alpha_0^2,$$

where $I = M\rho^2 = \text{moment of inertia.}$

Thus, with revolving masses, I takes the place of M , and α of v .

During deceleration, no external force or torque is applied. Thus,

$$O = Q + I \frac{d\alpha}{dt} = \text{torque of friction} + \text{torque of deceleration.}$$

(For sake of simplicity the small power given electrically is neglected.)

or
$$d\alpha = -\frac{Q}{I} dt, \text{ or, } \alpha = -\frac{Q}{I} t + C;$$

for $t = 0, \alpha = \alpha_0. \therefore C = \alpha_0.$

$$\therefore \alpha = \alpha_0 - \frac{Q}{I} t.$$

If T denotes the time at which the rotor stops, then for $t = T, \alpha = 0.$

$$\therefore 0 = \alpha_0 - \frac{Q}{I} T, \therefore T = \frac{I}{Q} \alpha_0.$$

And,
$$\alpha = \alpha_0 - \frac{\alpha_0}{T} t = \alpha_0 \left(1 - \frac{t}{T}\right).$$

Check whether all energy is spent at $t = T$, neglecting the supply of energy from the diminution of magnetic field and the consumption of energy in heat. The stored energy is $\frac{1}{2}I\alpha_0^2$.

The energy consumed by friction during deceleration is:

$$\int_0^T \text{force} \times \text{vel.} dt = \int_0^T Q 2\pi N dt = \int_0^T Q \alpha dt = Q \int_0^T \left(\alpha_0 - \frac{Q}{I} t\right) dt = Q \left[\alpha_0 T - \frac{Q}{I} \frac{T^2}{2}\right];$$

substituting,
$$T = \frac{I}{Q} \alpha_0,$$

$$\therefore \int_0^T Q \alpha dt = Q \left[\alpha_0 \frac{I}{Q} \alpha_0 - \frac{Q}{I} \frac{T^2}{2} Q^2 \alpha_0^2\right] = \frac{I}{2} \alpha_0^2, \text{ Q.E.D.}$$

Electrical Calculations.—If the field current remained constant during the deceleration (which it obviously does not), the arma-

ture voltage at speed α would be: $e_1 = \frac{\alpha}{\alpha_0} E$, so that due to the loss of speed alone, the armature voltage is reduced from E to $\frac{\alpha}{\alpha_0} E$.

If the field current is reduced from I to i , the flux is reduced from Φ to φ , and therefore the e.m.f. at constant speed is reduced in the proportion $\frac{i}{I_0}$.

Thus, at field excitation i and speed α , the armature voltage is $e = \frac{\alpha}{\alpha_0} \frac{i}{I_0} E$.

$$= \frac{i}{I_0} \frac{\alpha_0}{\alpha_0} \left(1 - \frac{t}{T}\right) E = \frac{i}{I_0} E \left(1 - \frac{t}{T}\right);$$

but

$$\frac{E}{I_0} = r,$$

$$\therefore e = ir \left(1 - \frac{t}{T}\right).$$

But the relation between the current and the e.m.f. is:

$$e = ir + L \frac{di}{dt},$$

or,

$$ir \left(1 - \frac{t}{T}\right) = ir + L \frac{di}{dt}, \text{ or, } \frac{di}{dt} + \frac{irt}{LT} = 0.$$

$$\therefore i = C \epsilon^{-\int \frac{rt}{LT} dt} = C \epsilon^{-\frac{r}{LT} \frac{t^2}{2}};$$

for

$$t = 0, i = I_0. \therefore C = I_0.$$

$$\therefore i = I_0 \epsilon^{-\frac{rt^2}{2TL}}.$$

The motor stops, when $t = T$, and when the current is:

$$i_0 = I_0 \epsilon^{-\frac{rT}{2L}}$$

Remembering the equation of the decaying current in an ordinary inductive circuit, $i = I_0 \epsilon^{-\frac{rT}{L}}$, it is evident that in the case of a decelerating self-exciting machine the current does not die as fast.

After the motor has stopped, the current obviously dies down according to the law:

$$\begin{aligned} i &= i_0 \epsilon^{-\frac{r}{L}(t-T)} \\ &= I_0 \epsilon^{-\frac{rT}{2L}} \epsilon^{-\frac{r}{L}(t-T)} = I_0 \epsilon^{-\frac{r}{L}\left(t - \frac{T}{2}\right)}. \end{aligned}$$

NOTE.—For a more detailed discussion of this see STEINMETZ'S "Transient Phenomena."

Verify the curve (a) in Fig. 9 in the case of a four-pole, 7.5-hp. motor having the following constants:

$P = 4$	$I_0 = 2.75$ amp.
$N = 20$	$E = 110$
$I = 0.25$	$r = 40$ ohms, total
$\Phi = 1.5$ megohms per pole	$n = 1000$ per pole
$P = 0.72$ hp.	

In large machines, the windage loss is frequently greater than the loss in the bearings.

The windage loss may be assumed to be proportional to the square of the velocity. In other words the torque necessary to overcome the windage is proportional to the speed.

Assuming again that the electric power is small and that it can be neglected then the equation connecting speed and time during deceleration becomes:

$$O = Q_1 + Q_2 \alpha + I \frac{d\alpha}{dt},$$

or,
$$\frac{d\alpha}{dt} + \frac{Q_2}{I} \alpha = -\frac{Q_1}{I}.$$

$$\therefore \alpha = -\frac{Q_1}{Q_2} + C \epsilon^{-\frac{Q_2}{I} t};$$

when $\alpha = \alpha_0, t = 0. \therefore C = \alpha_0 + \frac{Q_1}{Q_2}$

$$\therefore \alpha = -\frac{Q_1}{Q_2} + \left(\alpha_0 + \frac{Q_1}{Q_2}\right) \epsilon^{-\frac{Q_2}{I} t};$$

when

$$t = T, \text{ the motor stops, } \alpha = 0,$$

$$\therefore 0 = -\frac{Q_1}{Q_2} + \left(\alpha_0 + \frac{Q_1}{Q_2}\right) \epsilon^{-\frac{Q_2}{I} T},$$

$$\therefore \epsilon^{-\frac{Q_2}{I} T} = \frac{Q_1}{Q_2 \alpha_0 + Q_1}$$

$$\therefore \log \frac{Q_1}{Q_2 \alpha_0 + Q_1} = -\frac{Q_2}{I} T, \text{ or, } \log \frac{Q_2 \alpha_0 + Q_1}{Q_1} = \frac{Q_2}{I} T.$$

$$\therefore T = \frac{I}{Q_2} \log \frac{Q_2 \alpha_0 + Q_1}{Q_1}.$$

$$e = E_0 \frac{\alpha}{\alpha_0} \frac{i}{I_0} = \frac{\alpha}{\alpha_0} ir,$$

$$\therefore \frac{\alpha}{\alpha_0} ir = ir + L \frac{di}{dt},$$

or,

$$\frac{di}{dt} + \frac{ir}{L} \left(1 - \frac{\alpha}{\alpha_0}\right) = 0,$$

$$1 - \frac{\alpha}{\alpha_0} = 1 - \frac{1}{\alpha_0} \left[-\frac{Q_1}{Q_2} + \left(\alpha_0 + \frac{Q_1}{Q_2}\right) \epsilon^{-\frac{Q_2}{I}t} \right],$$

which, transformed, becomes:

$$\frac{\alpha}{\alpha_0} = A(1 - \epsilon^{-kt}),$$

where

$$A = 1 + \frac{Q_1}{Q_2 \alpha_0}$$

and

$$K = \frac{Q_2}{I}.$$

$$\therefore \frac{di}{dt} + \frac{irA}{L} (1 - \epsilon^{-kt}) = 0,$$

$$\therefore i = C \epsilon^{-\int P dx} = C \epsilon^{-\int \frac{rA}{L} (1 - \epsilon^{-kt}) dt},$$

but

$$\int \frac{rA}{L} (1 - \epsilon^{-kt}) dt = \int \frac{rA}{L} dt - \int \frac{rA}{L} \epsilon^{-kt} dt$$

$$= \frac{rA}{L} \left[t + \frac{e^{-kt}}{k} \right].$$

$$\therefore i = C \epsilon^{-\frac{rA}{L} \left[t + \frac{e^{-kt}}{k} \right]},$$

when $t = 0$, $i = I_0$;

$$\therefore C = I_0 \epsilon^{\frac{rA}{Lk}};$$

$$\therefore i = I_0 \epsilon^{-\frac{rA}{L} \left\{ t + \frac{1}{k} (1 - \epsilon^{-kt}) \right\}}.$$

If the problem given above is modified, so as to include a windage loss at full speed of 0.15 hp. as well as the bearing loss of 0.72 hp., the constants are:

$$r = 40,$$

$$I = 0.25,$$

$$L = 21\epsilon,$$

$$Q_2 = \frac{P_2 \cdot 550}{\alpha_0^2} = 0.00525,$$

$$\alpha_0 = 125.8,$$

$$Q_1 = 3.16.$$

T becomes 9.04 sec., and

$$A = 5.71,$$

$$\frac{Ar}{L} = 10.60,$$

$$K = 0.021,$$

$$\therefore i = I_0 \epsilon^{(-10.60t + 504.6 - 504.6 \epsilon^{-0.021t})}.$$

In curve b , Fig. 9, is given the relation between the current and time in this case.

The problems considered up to this point have all involved very simple integrations. Frequently, however, this is not the case, and to solve the differential equations, it is necessary to make algebraic transformations.

The most important of these transformations is to separate fractions into partial fractions.

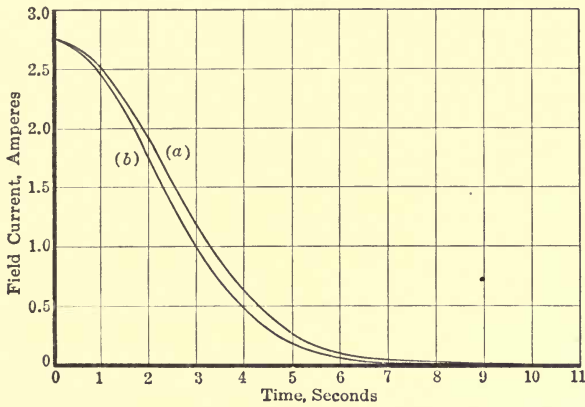

FIG. 9.

Almost any algebra deals with this; nevertheless it may be opportune to refer to it briefly here, although it is suggested that the student's memory be refreshed by reading, for instance, WILLSON'S "Advanced Algebra," from which the following is largely abstracted.

If $\frac{f(x)}{F(x)}$ is a fraction, that is, the numerator is of lower degree than the denominator.

It is known that $F(x)$ can always be expressed as the product of linear factors, which are not necessarily real.

If the factors are real, then $F(x)$ can be expressed as the product of real linear and quadratic factors. Two cases will be here considered.

First.—No factors are repeated.

Example.— $F(x) = (a_1x + b_1)(a_2x + b_2)(a_3x^2 + b_3x + c_3)$.

Then
$$\frac{f(x)}{F(x)} = \frac{A_1}{a_1x + b_1} + \frac{A_2}{a_2x + b_2} + \frac{A_3x + B_3}{a_3x^2 + b_3x + c_3},$$

where A_1 , A_2 , A_3 , and B_3 are constants, which can readily be found, since if the expression:

$a_0x^n + a_1x^{n-1} + a_2x^{n-2} + \dots + i = b_0x^n + b_1x^{n-1} + b_2x^{n-2} + \dots$
holds for all values of x , then the coefficients of like powers of x must be equal, thus $a_0 = b_0$, $a_1 = b_1$, etc.

Show that

$$\frac{x^2 + 1}{x(x-1)(x-2)(x^2+x+1)} = \frac{1}{2x} - \frac{2}{3(x-1)} + \frac{5}{14(x-2)} - \frac{4x+5}{21(x^2+x+1)}$$

Second.—Some factors of the denominator are repeated.

$$F(x) = (a_1x + b_1)^2(a_2x + b_2)(a_3x^2 + b_3x + c_3)^2$$

Then

$$\frac{f(x)}{F(x)} = \frac{A_1}{(a_1x+b_1)^2} + \frac{A_1^1}{a_1x+b_1} + \frac{A_2}{a_2x+b_2} + \frac{A_3x+B_3}{(a_3x^2+b_3x+C_3)^2} + \frac{A_3^1x+B_3^1}{a_3x^2+b_3x+c_3}$$

Prove that

$$\frac{2x^3 + b}{(x-1)^2(x-3)^2} = \frac{2}{(x-1)^2} + \frac{7}{2(x-1)} + \frac{15}{(x-3)^2} - \frac{3}{2(x-3)}$$

The application of this transformation is found in any transient phenomenon in which disproportionality between magnetomotive force and resulting flux exists.

As an example the condition governing the self-excitation of a direct-current shunt-wound generator will be considered. (For a more detailed discussion see STEINMETZ'S "Transient Phenomena.")

It will be assumed that the relation between the flux φ and the field current i can be sufficiently closely represented by FROELICH'S equation:

$$\varphi = \frac{ki}{1 + k_1i} \quad (1)$$

Let e_c be the e.m.f. generated per megaline of flux at normal speed, and e_0 be the normal e.m.f. at normal flux φ_0 .

Then

$$e_c = \frac{e_c}{\varphi_0}$$

The e.m.f. e corresponding to any other flux φ is:

$$e = e_c\varphi$$

The e.m.f. consumed by the resistance is ir .

The e.m.f. consumed by the changing flux is $\frac{n}{100} \frac{d\varphi}{dt}$

if φ is expressed in megalines

and n is the total number of turns enclosing the flux.

Thus

$$e_c\varphi = ir + \frac{n}{100} \frac{d\varphi}{dt}$$

from (1)

$$i = \frac{\varphi}{k - k_1\varphi}$$

$$\therefore e_c\varphi = \frac{\varphi r}{k - k_1\varphi} + \frac{n}{10^8} \frac{d\varphi}{dt}$$

Separating the variables

$$\begin{aligned} \frac{100}{n} dt &= \frac{k - k_1\varphi}{e\varphi(k - k_1\varphi) - \varphi r} d\varphi \\ &= \frac{k - k_1\varphi}{\varphi(e_c k - r - e_c k_1\varphi)} d\varphi. \end{aligned}$$

To integrate this the fraction is broken up into partial fractions thus:

$$\frac{100}{n} dt = \left[\frac{A}{\varphi} + \frac{B}{ek - r - k_1e_c\varphi} \right] d\varphi$$

and A is found to be $\frac{k}{e_c k - r}$

and B is found to be $\frac{k_1 r}{e_c k - r}$.

Integrating each term we get after a slight transformation

$$\frac{100}{n} t = \frac{k}{e_c k - r} \log \varphi - \frac{r}{e_c(e_c k - r)} \log (e_c k - r - k_1 e_c \varphi) + C.$$

If at the time of closing the field circuit the remanent flux is φ_r and the corresponding voltage = e_r then for $t = 0$, $\varphi = \varphi_r$, $e = e_r$.

When C is determined and the final expression becomes:

$$t = \frac{n}{100e_c(e_c k - r)} \left[k e_c \log \frac{e}{e_r} - r \log \frac{e_c k - r - k_1 e}{e_c k - r - k_1 e_r} \right].$$

The voltage ultimately reached is $e = e_0$ when $t = \infty$.

Thus

$$\log \frac{e_c k - r - k_1 e_0}{e_c k - r - k_1 e_r} = -\infty \text{ thus}$$

$$e_c k - r - k_1 e_0 = 0 \text{ or } e_0 = \frac{e_c k - r}{k_1}.$$

The greatest value of r which gives a positive value of e_0

$$r = e_c k.$$

The condition of self-excitation is thus $r \leq e_c k$.

Up to this point, the problems have involved inductive circuits, on which a direct-current e.m.f. has been impressed. In case of alternating current the impressed e.m.f. varies from instant to instant and, while a harmonic e.m.f. is usually assumed, frequently the variation represented by a wave is much more complex. As long, however, as the e.m.f. is obtained from a dynamo of symmetrical poles, no matter how shaped, the e.m.f. wave can be expressed by a series of sine functions of odd frequencies.

In the study of transient phenomena in connection with alternating current, the equations are derived for the fundamental wave only, that is, the instantaneous values of the e.m.f. are represented by $e = E \sin \theta$.

If it is desired to know the result with distorted waves, the simplest method is to treat each harmonic independently and to add the instantaneous values so obtained. If the effective value is desired the square root of the sum of the squares of the effective value of each wave should be taken.

As stated previously, the instantaneous value of the e.m.f. is generally expressed in two ways, either $e = E \sin \omega t$ or $e = E \sin \theta$, or the expression may be of more general form: $e = E \sin (\omega t + \alpha)$ and $e = E \sin (\theta + \alpha)$. In these expressions, e is the particular value of the e.m.f. at time t , or at phase angle θ , and E is the maximum value of the e.m.f. In the first case, the angle ωt is expressed in radians, not in degrees. ω is the angular velocity = $2\pi f$, where f is the frequency. The relation between radians and degrees is $360^\circ = 2\pi$ radians, thus 1 radian is $\frac{360}{2\pi} = 57.3^\circ$. To reduce equation $e = E \sin (\omega t + \alpha)$ to degrees it should therefore be written $e = E \sin (57.3 \omega t + \alpha)$, where in all cases α is expressed in degrees, as is customary. To reduce the expression to radians it should be written

$$e = E \sin \left(\omega t + \frac{\alpha}{57.3} \right).$$

Note in connection with this that in the expression, $y = \sin x$, x is expressed in radians, not in degrees. To bring it to degrees the equation becomes $y = \sin 57.3 x$.

In the development the value of the sine function

$$\sin x = x - \frac{x^3}{3} + \frac{x^5}{5} - \frac{x^7}{7} + \dots$$

x is again expressed in radians.

It is important to have this clearly in mind. It is well worth while to plot some curves of distorted waves from equations involving phase angle as well as radians.

Example No. 5.—Verify the e.m.f. wave in Fig. 10, $e = E_1 \sin \omega t + E_3 \sin (3 \omega t + \alpha)$ for $E_1 = 10$, $E_3 = 5$, $\alpha = 30^\circ$ and the frequency 25 cycles.

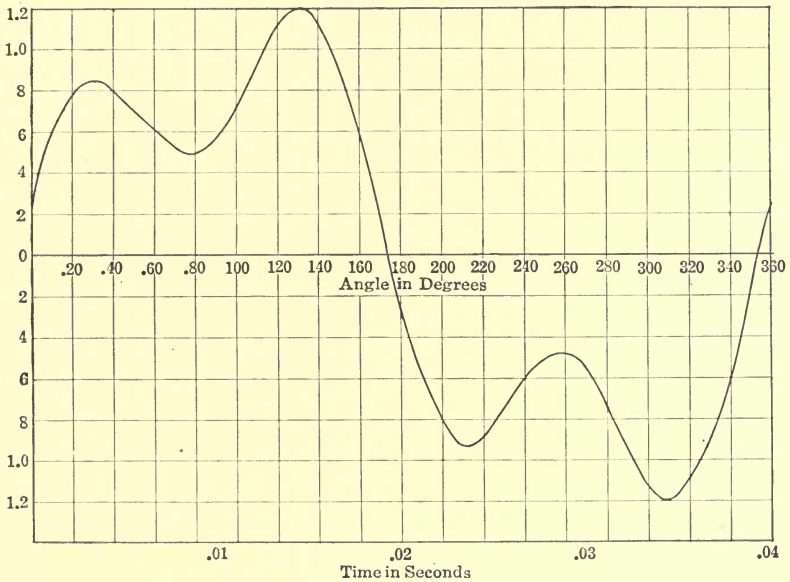

FIG. 10.

Prove by integration that with a distorted wave:

$$e = E_1 \sin (\omega t + \alpha_1) + E_3 \sin (3 \omega t + \alpha_3)$$

the effective value is $e_{eff} = \sqrt{e_1^2{}_{eff} + e_3^2{}_{eff}}$.

Thus in this instance, since the effective value of the fundamental wave is $\frac{E_1}{\sqrt{2}} = \frac{10}{\sqrt{2}} = 7.07$, and that of the triple harmonic is $\frac{E_3}{\sqrt{2}} = \frac{5}{\sqrt{2}} = 3.53$, the effective value of the wave

recorded by a voltmeter is $e = \sqrt{7.07^2 + 3.53^2} = 7.9$.

Referring to Fig. 11: prove that ammeter *A* when placed in a circuit carrying 10 amp. direct current, 8 amp. 60-cycle current, and 5 amp. 125-cycle current reads 13.7 amp.

Harmonic e.m.f. Impressed on a Circuit of Resistance and Inductance in Series.—Let time be counted from zero value of the impressed e.m.f. and let the e.m.f. be rising.

Thus $e = E \sin \omega t$ where e is the instantaneous value of the harmonic e.m.f. at time t . E is the maximum value. $\omega = 2\pi f$, is the angular velocity, f the frequency, r the resistance and L the inductance of the circuit.

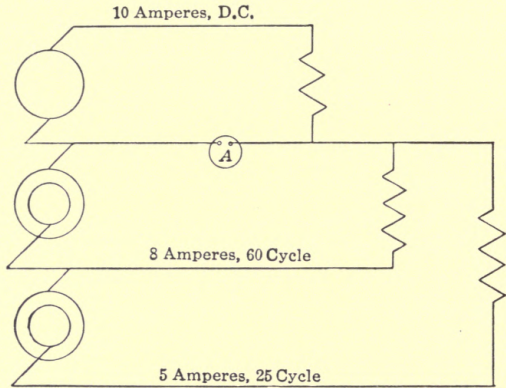

FIG. 11.

If i is the instantaneous value of the current when the e.m.f. is e , then:

$$e = E \sin \omega t = ir + L \frac{di}{dt} \quad (27)$$

or

$$\frac{di}{dt} + \frac{r}{L} i = \frac{E}{L} \sin \omega t \quad (28)$$

By comparing this equation with equation (2), it is seen that $\frac{r}{L} = P$ and $\frac{E}{L} \sin \omega t = Q$.

P is not a function of the independent variable t , but Q depends thereon, thus the solution is given in equation (8).

It is

$$i = e^{-\frac{r}{L}t} \left[\int e^{+\frac{r}{L}t} \frac{E}{L} \sin \omega t dt + C \right] \quad (29)$$

The solution of this equation depends upon solving

$$\int e^{+\frac{r}{L}t} \frac{E}{L} \sin \omega t dt = \frac{E}{L} \int e^{+\frac{r}{L}t} \sin \omega t dt.$$

$\frac{E}{L}$ is a constant and can be left out of consideration at present.

It is also convenient to substitute a single letter for $\frac{r}{L}$. Let then $\alpha = \frac{r}{L}$.

The immediate problem then is to solve $\int \epsilon^{\alpha t} \sin \omega t dt$.

An integral involving exponentials or sine functions is usually easy to solve, because the differential of the functions are similar to the functions.

$$\text{If } y = \epsilon^{\alpha x} \text{ then } \frac{dy}{dx} = \alpha \epsilon^{\alpha x}.$$

Similarly if $y = \sin \omega x$, then $\frac{dy}{dx} = \omega \cos \omega x$,

or if $y = \cos \omega x$, then $\frac{dy}{dx} = -\omega \sin \omega x$.

Thus

$$\int \epsilon^{\alpha t} dt = \frac{1}{\alpha} \epsilon^{\alpha t}$$

and

$$\int \sin \omega t dt = -\frac{1}{\omega} \cos \omega t.$$

Fortunately for the engineer there are only very few methods of integration that need to be known. One of these is "Integration by Parts."

That is:

$$\int u dv = uv - \int v du \quad (30)$$

In integral $\int \epsilon^{\alpha t} \sin \omega t dt$, let $u = \epsilon^{\alpha t}$ and $dv = \sin \omega t dt$.

$$\therefore du = \alpha \epsilon^{\alpha t} \text{ and } v = -\frac{1}{\omega} \cos \omega t$$

$$\therefore \int \epsilon^{\alpha t} \sin \omega t dt = -\frac{\epsilon^{\alpha t}}{\omega} \cos \omega t + \int \frac{\alpha}{\omega} \epsilon^{\alpha t} \cos \omega t dt \quad (31)$$

This equation is indeed more complicated than the original. It is evident, however, that by again integrating the last term in 31, an integral results which contains an exponential term $\epsilon^{\alpha t}$ and a sine term instead of the cosine term. Thus the final expression will contain integrals of the same trigonometrical and exponential functions, which therefore can be solved directly. However, it is somewhat more convenient to use another method.

Referring again to (30) let in this case:

$$u = \sin \omega t \text{ and } dv = \epsilon^{\alpha t} dt$$

$$\therefore du = \omega \cos \omega t dt \text{ and } v = \frac{1}{\alpha} \epsilon^{\alpha t}$$

$$\therefore \int \epsilon^{\alpha t} \sin \omega t dt = \frac{\epsilon^{\alpha t}}{\alpha} \sin \omega t - \int \frac{\omega}{\alpha} \epsilon^{\alpha t} \cos \omega t dt \quad (32)$$

By multiplying 31 by $\frac{\omega}{\alpha}$ and 32 by $\frac{\alpha}{\omega}$ and adding the two equations, it is readily seen that

$$\int \epsilon^{\alpha t} \sin \omega t \, dt = \frac{\epsilon^{\alpha t} \alpha \omega}{\omega^2 + \alpha^2} \left(\frac{\sin \omega t}{\omega} - \frac{\cos \omega t}{\alpha} \right) \quad (33)$$

Substituting $\alpha = \frac{r}{L}$ and remembering that x , the reactance corresponding to the inductance L is $2\pi fL = \omega L$ and that the impedance $z = \sqrt{r^2 + x^2}$.

Then
$$\int \epsilon^{\frac{r}{L} t} \sin \omega t \, dt = \epsilon^{+\frac{r}{L} t} \frac{L}{z^2} [r \sin \omega t - x \cos \omega t] \quad (34)$$

Let the angle of lag of current be β thus

$$\tan \beta = \frac{x}{r} \text{ and } r = z \cos \beta \quad (35)$$

$$x = z \sin \beta \quad (36)$$

Substituting the values in 34:

$$\int \epsilon^{\frac{r}{L} t} \sin \omega t \, dt = \epsilon^{+\frac{r}{L} t} \frac{L}{z} \sin (\omega t - \beta) \quad (37)$$

Referring to equation 29

$$i = \frac{E}{z} \sin (\omega t - \beta) + C \epsilon^{-\frac{r}{L} t} \quad (38)$$

The integration constant C is determined from the particular problem under consideration.

Assume that it is desired to find the value of the current at any instant after the switch is closed and the alternating e.m.f. is impressed upon the circuit, and that the switch is closed at time $t = t_1$, when the instantaneous value of the e.m.f. is $e = E \sin \omega t_1$.

Since, as has previously been discussed, it is impossible to establish a magnetic field instantaneously, the current can not flow at the first instant. Thus for $t = t_1$, $i = 0$. Substituting these values in equation 38, then:

$$0 = \frac{E}{z} \sin (\omega t_1 - \beta) + C \epsilon^{-\frac{r}{L} t_1},$$

$$\therefore C = \frac{E}{z} \epsilon^{\frac{r}{L} t_1} \sin (\omega t_1 - \beta),$$

Substituting this in (38)

$$i = \frac{E}{z} \left[\sin (\omega t - \beta) - \epsilon^{-\frac{r}{L} (t-t_1)} \sin (\omega t_1 - \beta) \right] \quad (39)$$

It is often convenient, to eliminate t entirely from the expression and to use the phase angle θ only and to express θ in degrees.

That is, the e.m.f. is expressed as $e = E \sin \theta$. In that case $\theta = \omega t = 2\pi ft$.

The exponential term $\epsilon^{-\frac{r}{L}(t-t_1)}$ becomes $\epsilon^{-\frac{r}{L\omega}(\theta-\theta_1)} = \epsilon^{-\frac{r}{x}(\theta-\theta_1)}$ if θ and θ_1 are expressed in radians or $\epsilon^{\frac{r}{x} \frac{(\theta-\theta_1)}{57.3}}$ if θ and θ_1 are expressed in degrees.

Thus when θ and θ_1 represent degrees

$$i = \frac{E}{z} \left[\sin(\theta - \beta) - \epsilon^{-\frac{r}{x} \frac{(\theta-\theta_1)}{57.3}} \sin(\theta_1 - \beta) \right] \quad (40)$$

The equation is, however, always written

$$i = \frac{E}{z} \left[\sin(\theta - \beta) - \epsilon^{-\frac{r}{x}(\theta-\theta_1)} \sin(\theta_1 - \beta) \right] \quad (41)$$

and it is understood that the exponential term should be expressed in radians.

Equation (41) can, of course, be derived directly by using the phase angle θ instead of ωt .

Thus

$$E \sin \theta = ir + L \frac{di}{dt}$$

may be written

$$E \sin \theta = ir + x \frac{di}{d\theta}, \quad (42)$$

where x is the reactance.

Thus,

$$x = 2\pi fL = \omega L$$

and

$$\omega t = \theta.$$

$$\therefore d\theta = \omega dt \text{ or } dt = \frac{d\theta}{\omega}$$

Prove that equation 41 is the solution of

$$E \sin \theta = ir + x \frac{di}{d\theta}$$

The exponential term in equation (41), while of importance during the first second or so, ceases to affect the result very shortly after the switch is closed.

Thus the equation for the current after the system is stable is

$$i = \frac{E}{Z} \sin(\theta - \beta) \quad (43)$$

The current lags behind the e.m.f., $E \sin \theta$, by an angle β , whose tangent is $\frac{x}{r}$.

The effective value of the e.m.f. is

$$E_{eff} = \frac{E}{\sqrt{2}}$$

and of the current

$$I_{eff} = \frac{E}{\sqrt{2}Z}$$

It is of interest to note that the transient term is a maximum when $\sin(\theta_1 - \beta) = 1$, that is $\theta_1 - \beta = 90$, or $\theta_1 = 90 + \beta$.

This value of θ_1 also gives the maximum value of the permanent current.

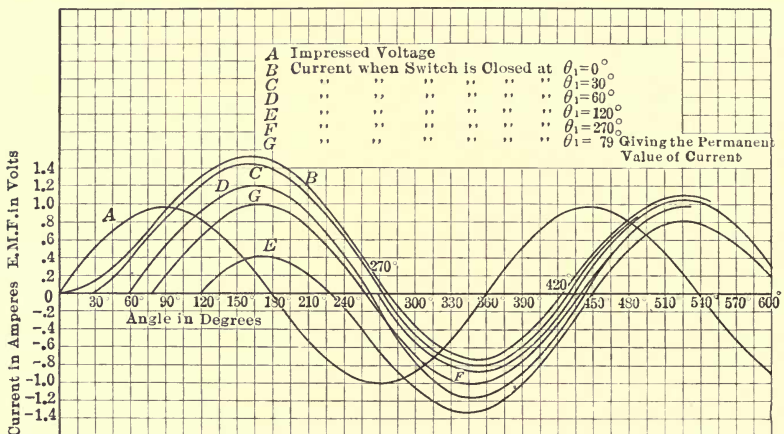

FIG. 12.

The exponential term is zero, that is, there is no transient effect if $\theta_1 - \beta = \theta$ or $\theta_1 - \beta = \theta + 2\pi$ or, in other words, if the circuit is closed at such a time as would give zero value of the permanent current.

Fig. 12 shows a series of such transient currents. Each curve corresponds to the closing of the switch at a particular value θ_1 of the phase of the e.m.f.

Thus, for instance, curve *D* shows the starting current when the e.m.f. wave has a phase angle of $+60^\circ$, that is, when $\theta_1 = 60^\circ$. These curves are calculated with the following constants

$$E = 1 \quad r = 0.196 \quad x = 0.98.$$

Problem No. 6.—Check some curve in Fig. 12.

It is of interest to study the rate at which energy is being sup-

plied at any instant. This is equal to the product of the e.m.f. and the current:

$$P = ci = E \sin \theta \times \frac{E}{Z} \left[\sin (\theta - \beta) - \epsilon^{-\frac{r}{x}(\theta - \theta_1)} \sin (\theta_1 - \beta) \right] \quad (44)$$

By simple transformations the equation becomes

$$P = \frac{E^2}{Z} \left[\frac{\cos \beta - \cos (2\theta - \beta)}{2} - \epsilon^{-\frac{r}{x}(\theta - \theta_1)} \sin (\theta_1 - \beta) \sin \theta \right] \quad (45)$$

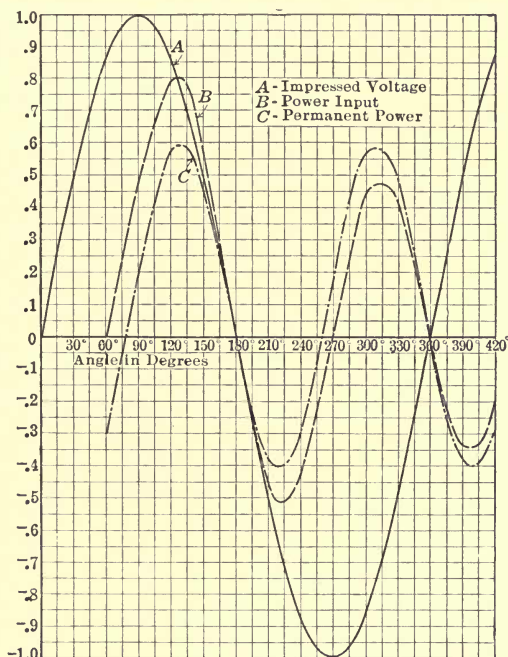

FIG. 13.

The first term in equation 45 must represent the power at any instant after the conditions have become stable. This power is expressed by

$$P_1 = \frac{E^2}{2Z} [\cos \beta - \cos (2\theta - \beta)] \quad (46)$$

It consists of two terms, one a constant term $\frac{E^2}{2Z} \cos \beta$, the other a term which changes with double frequency; the net result of which over a complete period is zero, since the positive values are as large as the negative. Thus while the instantaneous values of the power vary from instant to instant and may

alternate from positive to negative values there is a definite average power delivered, which is

$$P = \frac{E^2}{2Z} \cos \beta$$

The exponential part of the power,

$$P_2 = -\epsilon^{-r/x} (\theta - \theta_1) \sin (\theta_1 - \beta) \sin \theta \quad (47)$$

is gradually decreasing in magnitude as well as oscillating at normal frequency.

In Fig. 13 are given three curves; the first, *A*, is the wave of the impressed e.m.f.; the second, *B*, the power input; and the third, *C*, the power curve after conditions are stable. These curves have been based upon the constants given in problem 6 and are well worth reproducing by calculation.

The curves show that during the transient period the instant of maximum power is practically the same as that for permanent condition. They also show that the first rush of power is greater than that which corresponds to permanent condition, the reason being that the change of flux during the first part of the cycle is greater than during the corresponding time under stable condition.

CHAPTER II

PROBLEMS INVOLVING MUTUAL INDUCTANCE

Up to this point the problems considered have dealt with circuits of inductance and resistance only. However, in many circuits of commercial interest there are secondary circuits which are more or less closely coupled with the primary, and which influence the former materially. As instances of such circuits may be given the secondary winding of a transformer, the eddy currents in pole pieces of generators and motors, induced currents in telephone lines running parallel to transmission lines, etc.

Sometimes the secondary circuits carry currents by virtue of impressed e.m.fs., but frequently the currents are the result of the action of the primary currents. With a change of primary current obviously there is a change of the flux produced by the current and if this flux interlinks with the second circuit, e.m.fs. are induced therein, the values of which become higher as the interlinkage becomes more nearly perfect. While it is impossible to arrange two circuits so that all flux interlinking one will also interlink the other, the condition can be approached reasonably close under the most favorable conditions.

The limiting case is, of course, perfect mutual induction, which condition will therefore first be considered briefly.

Two Coils of Perfect Mutual Inductance.—Assume then that it is possible to place two coils so close together that there is no leakage flux between them, that is, so that all flux that surrounds one coil also surrounds the other. Let the first coil, the primary coil, have N_1 turns and r_1 ohms resistance, and the secondary coil N_2 turns and r_2 ohms resistance. Determine the open-circuit voltage of the second winding. When the first is connected to a source of constant potential E , we have obviously:

$$E = i_1 r_1 + \frac{N_1}{10^8} \frac{d\phi}{dt}$$

The rate of change of flux is thus

$$\frac{d\phi}{dt} = \frac{E - i_1 r_1}{N_1 10^{-8}}$$

Therefore the voltage of the second coil e_2 is

$$-\frac{N_2}{10^8} \frac{d\phi}{dt} = -\frac{N_2}{N_1}(E - i_1 r_1)$$

At the instant of starting, when i_1 is zero, the secondary voltage is $e_2 = -\frac{N_2}{N_1}E$, that is, it is proportional to the ratio of turns.

When the primary current reaches its constant value $I_0 = \frac{E}{r}$ the secondary voltage e_2 is zero. If the secondary winding has more turns than the primary, then at first the secondary voltage is higher than the impressed voltage. It decreases rapidly, however, and soon becomes zero.

Prove that the two voltages are equal numerically when

$$i_1 = \frac{E}{r_1 N_2} (N_2 - N_1).$$

Assume that two coils, which, when considered alone, have resistances and inductances of r_1, r_2 and L_1, L_2 , respectively, are placed so close together that there is perfect mutual inductance between them (which of course is in reality impossible). Find the open-circuit voltage of the second coil if the first coil is connected to a source of constant potential.

In the primary we have:

$$E = i_1 r_1 + L_1 \frac{di_1}{dt}.$$

The counter e.m.f. of self-induction of the primary coil is $-L_1 \frac{di_1}{dt}$, and thus the voltage of the second coil is

$$\therefore e_2 = -\frac{N_2}{N_1} L_1 \frac{di_1}{dt} = -\sqrt{\frac{L_2}{L_1}} L_1 \frac{di_1}{dt} = -\sqrt{\frac{L_2}{L_1}} (E - i_1 r_1).$$

Check the values of the primary current and secondary voltage as given in full lines of Fig. 14.

for

$$\begin{array}{llll} E = 10 & r_1 = 0.10 & L_1 = 2.5 & N_1 = 10 \\ & r_2 = 0.50 & L_2 = 10 & N_2 = 20 \end{array}$$

In the case referred to above the primary current will rise from zero to a final value of 100 amp., while the secondary voltage decreases from -20 volts to zero.

If when the primary current has reached its final value the coil is suddenly short-circuited, what will the primary current and secondary voltage be?

The primary current will decrease according to equation:

$$i_1 = I \epsilon^{-\frac{r_1}{L_1} t} = \frac{E}{r_1} \epsilon^{-\frac{r_1}{L_1} t}$$

$$e_2 = -\frac{N_2}{N_1} (E - i_1 r_1) = -\frac{EN_2}{N_1} \left(I - \epsilon^{-\frac{r_1}{L_1} t} \right).$$

Check numerically the two dotted curves in Fig. 13.

During the discharge of the primary the number of coulombs are

$$\int_0^\infty i_1 dt = \int_0^\infty I_1 \epsilon^{-\frac{r_1}{L_1} t} dt = 100 \frac{L_1}{r_1} = 2500 \text{ coulombs.}$$

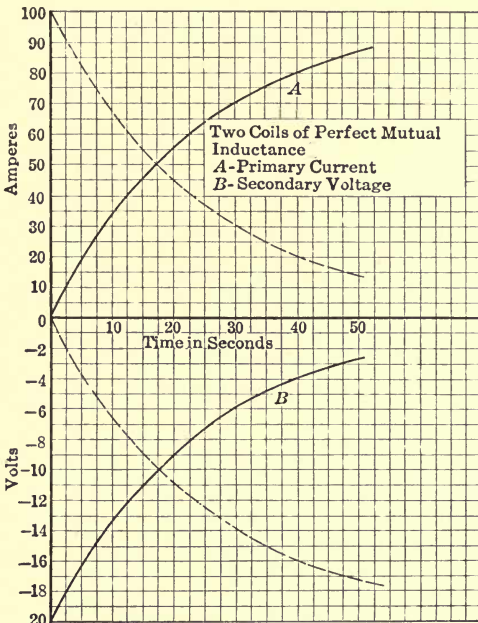

FIG. 14.

Obviously, when connecting the primary to the source of supply, the number of coulombs required up to the time when the current becomes stationary is infinite, since it takes infinite time for the current to reach this value.

Two coils of resistances and inductances of r_1, r and $L_1 L$ are connected in series and placed so close together that it is assumed that they have perfect mutual inductance. What will be the resultant resistance and inductance (a), if the coils are wound

in the same direction; (b), if the coils are wound in opposite directions?

The inductance of an air coil is subject to rigid mathematical determination, but the complete solution is very cumbersome. However, one of the best approximations, that of BROOKS and TURNER, published as an Engineering Experiment Station Bulletin by the University of Illinois, is:

$$L = \frac{cm^2}{10^9(b+c+R)} \times \frac{10b+12c+2R}{10b+10c+1.4R} \times 0.5 \log_{10} \left(100 + \frac{14R}{2b+3c} \right) \quad (1)$$

For coils which are not extremely thin or extremely long, this equation becomes approximately:

$$L = \frac{cm^2}{(b+c+0.9R)10^9} \quad (2)$$

Where L is expressed in henrys

cm = centimeter length of wire

b and c are the height and thickness respectively of the coil and R the *outside* radius, all in cm .

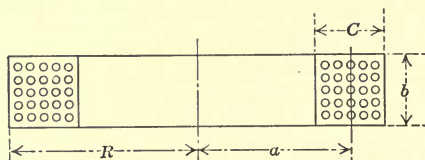

FIG. 15.

The maximum inductance is obtained when $b = C$ and $R = 2C$ (see Fig. 15). Then

$$L = - \frac{0.27\overline{Cm}^2}{C \times 10^9} \text{ henrys.}$$

It is seen that the inductance is proportional to the square of the total length of wire, which is, of course, proportional to the turns. Thus the inductance is proportional to the square of the number of turns, or

$$L = KN^2.$$

(a) Coils in the same direction.

Let N be the number of turns in the first coil, or,

$$N = \sqrt{\frac{L}{K}};$$

and N_1 the number of the turns in the second coil, or,

$$N_1 = \sqrt{\frac{L_1}{K}}.$$

The total number of turns in the two coils when considered as one coil (which is permissible when perfect mutual inductance is assumed) is

$$N_0 = N + N_1 = \frac{\sqrt{L} + \sqrt{L_1}}{\sqrt{K}}.$$

The combined inductance is then

$$L_0 = KN_0^2 = (\sqrt{L} + \sqrt{L_1})^2 = L + L_1 + 2\sqrt{LL_1}.$$

The resistance is obviously $r_0 = r + r_1$.

(b) By similar reasoning it is found that if the turns are in opposite directions

$$L_0 = L + L_1 - 2\sqrt{LL_1} \text{ and } r_0 = r + r_1.$$

From the above it is evident that the equation for the starting current, for instance, is:

$$i = \frac{E}{r_0} \left[1 - e^{-\frac{r_0}{L_0} t} \right].$$

Two Coils of Perfect Mutual Inductance Connected Simultaneously to Sources of Constant e.m.fs. E and E_1 .—Let r , r_1 and L , L_1 be the resistance and inductances respectively, and assume that the circuits are closed at the same instant. Assume first that the coils are connected in the same direction, that is, in such a way that the permanent current in both coils will produce magnetic fields of the same polarity. It is evident that in this case the impressed e.m.f. has to overcome not only the resistance and inductance drop due to the current in the coil, but also the e.m.f. which by transformer action is induced in one coil by the change of current in the other.

Consider one coil alone, for instance the second coil: The counter e.m.f. of this coil is $-L_1 \frac{di_1}{dt}$. If it has N_1 turns, the voltage per turn is $-\frac{L_1}{N_1} \frac{di_1}{dt}$. Since it has been assumed that

there is no leakage field between the two coils, it is evident that this same voltage per turn is induced in the first coil by the current in the second. Thus the "transformer" e.m.f. in the first coil having N turns is $-\frac{N}{N_1} L_1 \frac{di_1}{dt}$, and similarly the transformer e.m.f. produced in the second coil by the current in the first is

$$-\frac{N_1}{N} L \frac{di}{dt}.$$

But

$$\frac{N}{N_1} = \sqrt{\frac{L}{L_1}};$$

therefore the e.m.f. in the first coil caused by the mutual flux is

$$-\sqrt{\frac{L}{L_1}} L_1 \frac{di_1}{dt} = -\sqrt{LL_1} \frac{di_1}{dt}.$$

Thus it is seen how, when the mutual inductance usually denoted by M is perfect, $M = \sqrt{LL_1}$. In reality M is always smaller than $\sqrt{LL_1}$. The general equation dealing with e.m.fs. consumed by resistance, inductance and mutual inductance, are then

$$E = ir + L \frac{di}{dt} + M \frac{di_1}{dt} \quad (3)$$

and

$$E_1 = i_1 r_1 + L_1 \frac{di_1}{dt} + M \frac{di}{dt} \quad (4)$$

To solve for instance i the following transformation is convenient, multiplying (3) by L_1 and (4) by $-M$ and add the equations so obtained.

It is:

$$\begin{aligned} L_1 E - M E_1 &= L_1 i r + L L_1 \frac{di}{dt} \\ &\quad - M i_1 r - M^2 \frac{di}{dt} \end{aligned} \quad (5)$$

Since with perfect mutual inductance

$$M^2 = L L_1 \quad (6)$$

$$i_1 = \frac{L_1 i r - L_1 E + M E_1}{M r_1} \quad (7)$$

$$\therefore \frac{di_1}{dt} = \frac{L_1 r}{M r_1} \frac{di}{dt}$$

Substituting this in equation (3):

$$\begin{aligned} E &= ir + L \frac{di}{dt} + L_1 \frac{r}{r_1} \frac{di}{dt} \\ &= ir + \frac{L_1 r_1 + L_1 r}{r_1} \frac{di}{dt} \end{aligned} \quad (8)$$

or
$$\frac{di}{dt} + \frac{rr_1}{Lr_1 + L_1r} i = \frac{Er_1}{Lr_1 + L_1r}.$$

Thus,
$$i = \frac{E}{r} + C\epsilon^{-\frac{rr_1}{Lr_1 + L_1r}t} \tag{9}$$

To determine the integration constant C , it would be a mistake to assume that the current i is zero when $t = 0$. All that is known is that the combined coil can not be surrounded instantaneously by a flux—it takes some time to produce or alter a magnetic field, because a transfer of energy is involved. It is possible that currents will flow the very first instant, currents which produce m.m.fs. of equal magnitude but in opposite direction. One particular case of this would be where the currents were zero, but this is not a general solution.

What is known, then, is that no flux will exist the first instant. Thus the m.m.fs. must be equal and opposite, and since the cross-section of the magnetic flux and the direction of the turns are assumed the same in both coils, it follows that for

$t = 0, iN = -i_1N_1$
 or
$$i_1 = -\frac{N}{N_1} i = -i\sqrt{\frac{L}{L_1}} \tag{10}$$

Substituting this value in equation (7)

$$-i\sqrt{\frac{L}{L_1}} = \frac{L_1\dot{i}r - L_1E + ME_1}{Mr_1},$$
 or
$$i = \frac{L_1E - ME_1}{Lr_1 + L_1r} \tag{11}$$

for $t = 0.$

$$\frac{L_1E - ME_1}{Lr_1 + L_1r} - \frac{E}{r} + C$$

$$\therefore C = -\frac{ME_1r + LEr_1}{r(Lr_1 + L_1r)}$$

$$\therefore i = \frac{E}{r} - \frac{ME_1r + LEr_1}{r(Lr_1 + L_1r)} \epsilon^{-\frac{rr_1}{Lr_1 + L_1r}t} \tag{12}$$

Similarly i_1 is found to be

$$i_1 = \frac{E_1}{r_1} - \frac{MEr_1 + L_1E_1r}{r_1(Lr_1 + L_1r)} \epsilon^{-\frac{rr_1}{Lr_1 + L_1r}t} \tag{13}$$

Problem No. 7.—Prove by complete calculation that if the terminals of the second coil are reversed the following are the equations of the currents

$$i = \frac{E}{r} - \frac{LEr_1 - ME_1r}{r(Lr_1 + L_1r)} \epsilon^{-\frac{rr_1}{Lr_1 + L_1r} t} \quad (14)$$

$$i_1 = \frac{E_1}{r_1} - \frac{L_1E_1r - MEr_1}{r_1(Lr_1 + L_1r)} \epsilon^{-\frac{rr_1}{Lr_1 + L_1r} t} \quad (15)$$

In the case that the two coils are excited from the same direct-current busbars when $E = E_1$ the equations become:

For coils wound in the same direction:

$$i = \frac{E}{r} \left[1 - \frac{Lr_1 + Mr}{Lr_1 + L_1r} \epsilon^{-\frac{rr_1}{Lr_1 + L_1r} t} \right] \quad (16)$$

$$i_1 = \frac{E}{r_1} \left[1 - \frac{L_1r + Mr_1}{Lr_1 + L_1r} \epsilon^{-\frac{rr_1}{Lr_1 + L_1r} t} \right] \quad (17)$$

For coils wound in opposite direction:

$$i = \frac{E}{r} \left[1 - \frac{Lr_1 - Mr}{Lr_1 + L_1r} \epsilon^{-\frac{rr_1}{Lr_1 + L_1r} t} \right] \quad (18)$$

$$i_1 = \frac{E}{r_1} \left[1 - \frac{L_1r - Mr_1}{Lr_1 + L_1r} \epsilon^{-\frac{rr_1}{Lr_1 + L_1r} t} \right] \quad (19)$$

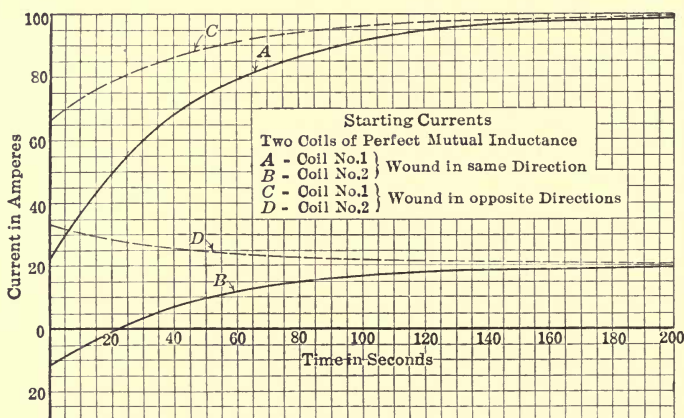

FIG. 16.

In Fig. 16 are given four curves showing the currents in two such coils of perfect mutual inductance, having the following constants:

$$r = 0.10$$

$$r_1 = 0.50$$

$$L = 2.5$$

$$L_1 = 10.0$$

$$E = E_1 = 10 \text{ volts.}$$

It is assumed that they are connected in parallel to the same source of direct current at a constant potential of 10 volts. The full-drawn curves correspond to the condition in which the turns are in the same direction; the dotted curves to that in which the turns are in opposite directions. It is well to verify these curves by calculation. It is of interest to note from the full-drawn curves that, while the two coils are connected to the same source of constant potential, during the first few seconds the currents actually flow in opposite direction. The *second* coil having twice as many turns as the *first*, and therefore a smaller final value of current, has a current of negative value at the first instant of one-half the magnitude of the current in the first coil. Eventually the currents become positive and are proportional inversely as the ohmic resistances.

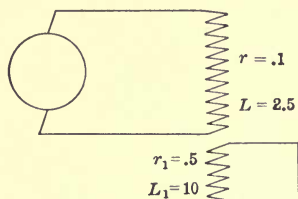

FIG. 17.

It is of interest to deduce the equations of the currents in the two coils when the first is connected to a source of constant potential, and the second is short-circuited upon itself, as shown diagrammatically in Fig. 17.

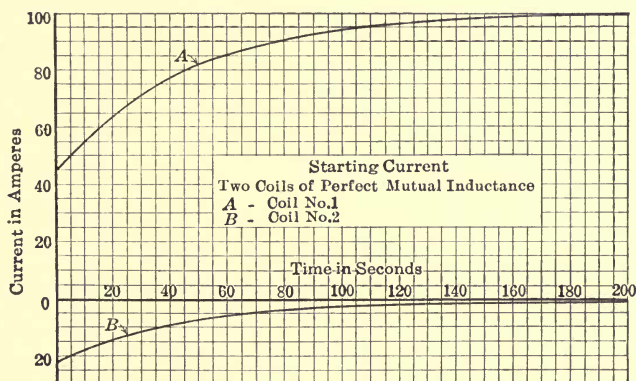

FIG. 18.

Prove that with the coils wound in the same direction:

$$i = \frac{E}{r} \left[1 - \frac{Lr_1}{Lr_1 + L_1r} \epsilon^{-\frac{rr_1}{Lr_1 + L_1r} t} \right] \tag{20}$$

$$i_1 = -\frac{MEr}{r_1(Lr_1 + L_1r)} \epsilon^{-\frac{rr_1}{Lr_1 + L_1r} t} \tag{21}$$

In Fig. 18, which gives the values of the currents, it is of interest to note that the current in the second coil, under this condition, remains negative and approaches a value of zero. The initial values of the currents are twice as great as before. Thus the impedance is greatly reduced, as would be expected by the presence of the short-circuited winding.

As a further illustration consider:

Two similar coils having perfect mutual induction and calculate the currents in the two coils when a sine wave of e.m.f. is impressed upon one coil while the other is short-circuited.

Referring to Fig. 19

$$\begin{aligned} L_1 &= L_2 = L \\ M &= \sqrt{L_1 L_2} = L \\ r_1 &= r_2 = r. \end{aligned}$$

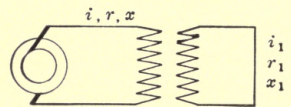

FIG. 19.

The equations evidently become:

$$\left. \begin{aligned} E \sin \theta &= ir + x \frac{di}{d\theta} + x \frac{di_1}{d\theta} \\ 0 &= i_1 r + x \frac{di_1}{d\theta} + x \frac{di}{d\theta} \end{aligned} \right\}$$

$$\therefore i - i_1 = \frac{E}{r} \sin \theta \text{ and } \frac{di}{d\theta} - \frac{di_1}{d\theta} = \frac{E}{r} \cos \theta \quad (22)$$

$$\therefore 0 = i_1 r + x \frac{di_1}{d\theta} + \frac{Ex}{r} \cos \theta + x \frac{di_1}{d\theta}$$

and

$$\frac{di_1}{d\theta} + \frac{r}{2x} i_1 = -\frac{E}{2r} \cos \theta$$

$$\begin{aligned} \therefore i_1 &= -\epsilon^{-\frac{r}{2x}\theta} \int \epsilon^{\frac{r\theta}{2x}} \frac{E}{2r} \cos \theta d\theta + C \epsilon^{-\frac{r}{2x}\theta} \\ &= -\frac{E}{Z_0} \frac{x}{r} \cos(\theta - \varphi) + C \epsilon^{-\frac{r}{2x}\theta} \end{aligned} \quad (23)$$

where

$$Z_0 = \sqrt{r^2 + (2x)^2}.$$

The condition determining the integration constant is that when the switch is closed no flux exists, thus $i = -i_1$.

Let then the switch be closed when $\theta = \theta_1$.

Thus from (22)

$$-2i_1 = \frac{E}{r} \sin \theta_1 \quad (24)$$

and from (23)

$$i_1 = -\frac{E}{Z_0} \frac{x}{r} \cos(\theta_1 - \varphi) + C \epsilon^{-\frac{r}{2x}\theta_1} \quad (25)$$

From (24) and (25)

$$C = \epsilon^{\frac{r}{2x} \theta_1} \left[\frac{Ex}{Z_0 r} \cos(\theta_1 - \varphi) - \frac{E}{2r} \sin \theta_1 \right]$$

$$\therefore i_1 = -\frac{E}{r} \left[\frac{x}{Z_0} \cos(\theta - \varphi) - \epsilon^{-\frac{r}{2x}(\theta - \theta_1)} \right] \left[\frac{x}{Z_0} \cos(\theta_1 - \varphi) - \frac{\sin \theta_1}{2} \right] \quad (26)$$

The transient term disappears when

$$\frac{x}{Z_0} \cos(\theta_1 - \varphi) = \frac{\sin \theta_1}{2}.$$

Expanding and substituting it is readily seen that this occurs when $\tan \theta_1 = \frac{2x}{r}$, that is when $\theta_1 = \varphi$.

The transient is a maximum when:

$$\frac{d}{d\theta_1} \left[\frac{x}{Z_0} \cos(\theta_1 - \varphi) - \frac{\sin \theta_1}{2} \right] = 0$$

that is when $\tan \theta_1 = -\frac{r}{2x}$ or $\theta_1 = \varphi - 90^\circ$.

Limiting Cases.—(a) r small compared with $2x$. $\therefore \varphi = 90^\circ$ and $\cos(\theta - \varphi) = \sin \theta$ and $\cos \varphi = 0$.

The transient effect is greatest when

$$\therefore i_1 = -\frac{E}{r} \sin \theta \text{ and } i = \frac{E}{2r} \sin \theta \quad (27)$$

(b) r large compared with $2x$ when

$$i_1 = \frac{E}{ir} \text{ and } i = -\frac{E}{2r} \quad (28)$$

When dealing with commercial problems involving mutual inductance it is never possible except as a first approximation to assume perfect mutual inductance M^2 is always smaller than LL . In that case the solution demands differential equations of the second or even higher order.

Fortunately, however, the solutions of these equations are as a rule simple.

The majority come under the class of linear differential equations with constant coefficient or they are of the types given below.¹

¹For a complete discussion see "A Course in Mathematics," WOODS AND BAILEY, vol. II; "Differential Equations," JOHNSON; "Differential Equations," MURRAY, or indeed almost any book on differential equations.

First. $\frac{d^2y}{dx^2} = f(x)$ = an expression that is a function of x .

Second. $\frac{d^2y}{dx^2} = f\left(x, \frac{dy}{dx}\right)$ = an expression that is a function of x and the first derivative of y with respect to x .

Third. $\frac{d^2y}{dx^2} = f\left(y, \frac{dy}{dx}\right)$

Fourth. $\frac{d^2y}{dx^2} = f(y)$.

Fifth. Linear differential equations $\frac{d^2y}{dx^2} + a \frac{dy}{dx} + by = X$.

First. $\frac{d^2y}{dx^2} = f(x)$ = a function of the independent variable only. By integration we get:

$$\frac{dy}{dx} = \int f(x)dx + C_1$$

and

$$y = \int \int f(x)dx^2 + C_1x + C_2.$$

This is equally true for $\frac{d^ny}{dx^n} = f(x)$

Second. $\frac{d^2y}{dx^2} = f\left(x, \frac{dy}{dx}\right)$.

Let

$$\frac{dy}{dx} = p, \quad \frac{d^2y}{dx^2} = \frac{dp}{dx}$$

$\therefore X \frac{dp}{dx} = f(x, p)$ which is of the first order of p and x .

If we can find p from this equation then we can find y because $\frac{dy}{dx} = p$.

Third. $\frac{d^2y}{dx^2} = f\left(y, \frac{dy}{dx}\right)$.

Let

$$\frac{dy}{dx} = p \quad \therefore \frac{d^2y}{dx^2} = \frac{dp}{dx} = \frac{dp}{dy} \cdot \frac{dy}{dx} = p \frac{dp}{dy}$$

$\therefore X p \frac{dp}{dy} = f(y, p)$ which equation is of the first order of p and y .

If we can find p from this equation we can find y , since $\frac{dy}{dx} = p$.

Fourth. $\frac{d^2y}{dx^2} = f(y)$

multiply both sides by $2 \frac{dy}{dx} dx$

$$2 \frac{d^2y}{dx^2} \cdot \frac{dy}{dx} \cdot dx = 2f(y) \frac{dy}{dx} dx$$

$$d \left[\left(\frac{dy}{dx} \right)^2 \right] = 2f(y) dy.$$

Integrating

$$\left(\frac{dy}{dx} \right)^2 = \int 2f(y) dy + C$$

or

$$\frac{dy}{dx} = \sqrt{\int 2f(y) dy + C}$$

or

$$\frac{dy}{\sqrt{\int 2f(y) dy + C}} = dx$$

or

$$\int \frac{dy}{\sqrt{2 \int f(y) dy + C}} = x + C_1$$

Fifth.—Linear differential equations of the second order with constant coefficients. If the coefficients are not constant, the solution is quite complicated. It is therefore omitted here. As a matter of fact in almost all problems the coefficients *are* constants.

$$\frac{d^2y}{dx^2} + a \frac{dy}{dx} + by = X \tag{29}$$

where a and b are constants and X is either a function of x or a constant or zero.

For convenience the symbol D which represents the differential operator $\frac{d}{dx}$ is introduced.

D means one operation of differentiation in respect to x , D^2 two operations of differentiation in respect to x .

Thus equation (29) can be written

$$\begin{aligned} D^2y + aDy + by &= X \\ (D^2 + aD + b)y &= X \end{aligned} \tag{30}$$

from this follows that

$$y = \frac{X}{D^2 + aD + b}$$

Obviously this does not mean an ordinary fraction but is simply a symbol to express the solution of equation (29). The denominator on the right-hand side is not a number but is an operator which has a definite meaning, so for instance $(D^2 + aD + b)e^{mx}$

really is the sum of three terms the first of which for instance is obtained by differentiating ϵ^{mx} twice with respect to x , the second once with respect to x , etc.,

The expression is:

$$m^2\epsilon^{mx} + am\epsilon^{mx} + b\epsilon^{mx}$$

Equation (30) can, as will be shown, be written

$$(D - m_1)(D - m_2)y = X \quad (31)$$

$$(D - m_2)y \text{ means } \frac{dy}{dx} - m_2y.$$

Thus

$$\begin{aligned} (D - m_1)(D - m_2)y &= \frac{d}{dx} \left(\frac{dy}{dx} - m_2y \right) - m_1 \left(\frac{dy}{dx} - m_2y \right) \\ &= \frac{d^2y}{dx^2} - m_2 \frac{dy}{dx} - m_1 \frac{dy}{dx} + m_1m_2y \\ &= \frac{d^2y}{dx^2} - (m_1 + m_2) \frac{dy}{dx} + m_1m_2y \quad (32) \end{aligned}$$

(Incidentally it is seen that the same result would be obtained by the simple multiplication of (31) treating D as an ordinary quantity). Comparing equations (29) and (32) it is seen that

$$-(m_1 + m_2) = a$$

and

$$m_1m_2 = b.$$

From these equations m_1 and m_2 can be expressed in terms of a and b which are known.

A slight consideration will show that m_1 and m_2 are also the roots of the so-called auxiliary equation $m^2 + am + b = 0$, which corresponds to the so-called complementary function

$$\frac{d^2y}{dx^2} + a \frac{dy}{dx} + by = 0$$

and the auxiliary equation corresponding thereto

$$m^2 + am + b = 0$$

$$\therefore m = -\frac{a}{2} \pm \sqrt{\frac{a^2}{4} - b}$$

and

$$m_1 = -\frac{a}{2} + \sqrt{\frac{a^2}{4} - b} \quad (33)$$

$$m_2 = -\frac{a}{2} - \sqrt{\frac{a^2}{4} - b} \quad (34)$$

The rule then is to solve the so-called auxiliary equation

$$m^2 + am + b = 0$$

and find the values of m_1 and m_2

Then write,

$$(D - m_1)(D - m_2)y = X.$$

To solve for y

Let
$$u = (D - m_2)y \tag{35}$$

$$(D - m_1)u = X$$

and

$$\frac{du}{dx} - m_1u = X$$

$$u = \epsilon^{m_1x} \int \epsilon^{-m_1x} X dx + C_1 \epsilon^{m_1x}.$$

From (35)

$$\frac{dy}{dx} - m_2y = \epsilon^{m_1x} \int \epsilon^{-m_1x} X dx + C_1 \epsilon^{m_1x} = X_1$$

$$y = \epsilon^{m_2x} \int \epsilon^{-m_2x} X_1 dx + C_2 \epsilon^{m_2x}.$$

Instance:

$$\frac{d^2y}{dx^2} - 3 \frac{dy}{dx} + 2y = \cos x$$

$$m^2 - 3m + 2 = 0$$

$$m = 1.5 \pm \sqrt{2.25 - 2} = 1.5 \pm 0.5 \begin{cases} m_1 = 2 \\ m_2 = 1 \end{cases}$$

$$(D - 1)(D - 2)y = \cos x$$

$$(D - 1)u = \cos x$$

$$\frac{du}{dx} - u = \cos x$$

$$u = \epsilon^x \int \epsilon^{-x} \cos x dx + C_1 \epsilon^x$$

but

$$\epsilon^x \int \epsilon^{-x} \cos x dx = \frac{1}{2} (\sin x - \cos x) \text{ by simple integration}$$

$$(D - 2)y = \frac{1}{2} (\sin x - \cos x) + C_1 \epsilon^x = X_1$$

$$\frac{dy}{dx} - 2y = \frac{(\sin x - \cos x)}{2} + C_1 \epsilon^x = X_1$$

$$y = \epsilon^{2x} \int \epsilon^{-2x} X_1 dx + C_2 \epsilon^{2x}.$$

The three integrals involved are readily solved and the result is

$$\frac{\cos x}{10} - 3 \frac{\sin x}{10} - C_1 \epsilon^x + C_2 \epsilon^{2x}.$$

In many cases a simpler integration is obtained by the following method which involves the breaking up of a fraction in partial fractions.

It is known from algebra that if the equation given below holds for all values of x then the coefficients of the like powers of x are equal.

$$a_0x^n + a_1x^{n-1} + a_n = b_0x^n + b_1x^{n-1} + b_n$$

Thus

$$a_0 = b_0$$

$$a_1 = b_1$$

$$a_2 = b_2$$

Equation $\frac{d^2y}{dx^2} + a \frac{dy}{dx} + by = X$ can be written

$$(D - m_1)(D - m_2)y = X \text{ or } y = \frac{X}{(D - m_1)(D - m_2)}$$

But it is known from algebra that the fraction

$$\frac{1}{(D - m_1)(D - m_2)} = \frac{A}{D - m_1} + \frac{B}{D - m_2}$$

where A and B are to be determined.

$$\frac{1}{(D - m_1)(D - m_2)} = \frac{A(D - m_2) + B(D - m_1)}{(D - m_1)(D - m_2)}$$

This equation shall hold for all values of D .

Rearranging the equation we get:

$$\frac{1}{(D - m_1)(D - m_2)} = \frac{D(A + B) - (Am_2 + Bm_1)}{(D - m_1)(D - m_2)}$$

On account of the identity the coefficient for D must be zero and the constant terms must be equal, thus

$$A + B = 0 \text{ or } A = -B$$

and

$$Am_2 + Bm_1 = -1$$

$$B = \frac{1}{m_2 - m_1} \text{ and } A = -\frac{1}{m_2 - m_1}$$

$$y = \frac{X}{m_2 - m_1} \left[-\frac{1}{D - m_1} + \frac{1}{D - m_2} \right]$$

$$= \frac{X}{m_1 - m_2} \left[\frac{1}{D - m_1} - \frac{1}{D - m_2} \right]$$

Let

$$y = u + v$$

$$u = \frac{1}{m_1 - m_2} \frac{X}{D - m_1} \tag{36}$$

and

$$v = -\frac{1}{m_1 - m_2} \frac{X}{D - m_2} \tag{37}$$

Equation (36) written out is

$$\frac{du}{dx} - m_1 u = \frac{X}{m_1 - m_2}$$

$$u = \frac{\epsilon^{m_1 x}}{m_1 - m_2} \int \epsilon^{-m_1 x} X dx + C_1 \epsilon^{m_1 x}.$$

Similarly

$$v = - \frac{\epsilon^{m_2 x}}{m_1 - m_2} \int \epsilon^{-m_2 x} X dx + C_2 \epsilon^{m_2 x}.$$

The general solution is thus

$$y = C_1 \epsilon^{m_1 x} + C_2 \epsilon^{m_2 x} + \frac{\epsilon^{m_1 x}}{m_1 - m_2} \int \epsilon^{-m_1 x} X dx$$

$$- \frac{\epsilon^{m_2 x}}{m_1 - m_2} \int \epsilon^{-m_2 x} X dx.$$

When X is a constant = K

$$\frac{d^2 y}{dx^2} + a \frac{dy}{dx} + by = K.$$

The solution evidently becomes:

$$y = C_1 \epsilon^{m_1 x} + C_2 \epsilon^{m_2 x} + \frac{K}{b}.$$

When X is zero the equation is called the complementary function and its solution is found by making $K = 0$ in the above.

The solution of the equation,

$$\frac{d^2 y}{dx^2} + a \frac{dy}{dx} + by = 0$$

is

$$y = C_1 \epsilon^{m_1 x} + C_2 \epsilon^{m_2 x}.$$

Before leaving the subject it is necessary to discuss the values of m_1 and m_2 which involve a square root in (33) and (34) which might be real, imaginary or zero.

(a) The square root is real, that is $\frac{a^2}{4} > b$.

We have shown then that m_1 and m_2 depend upon the auxiliary equation $\frac{d^2 y}{dx^2} + a \frac{dy}{dx} + by = 0$ and that the solution of this equation is,

$$y = C_1 \epsilon^{m_1 x} + C_2 \epsilon^{m_2 x}$$

$$= C_1 \epsilon^{\left(-\frac{a}{2} + \sqrt{\frac{a^2}{4} - b}\right)x} + C_2 \epsilon^{\left(-\frac{a}{2} - \sqrt{\frac{a^2}{4} - b}\right)x}$$

$$= \epsilon^{-\frac{a}{2}x} \left[C_1 \epsilon^{x \sqrt{\frac{a^2}{4} - b}} + C_2 \epsilon^{-x \sqrt{\frac{a^2}{4} - b}} \right].$$

(b) the square root is imaginary, that is $b > \frac{a^2}{4}$

then

$$y = C_1 \epsilon^{\left(-\frac{a}{2} + j\sqrt{b - \frac{a^2}{4}}\right)x} + C_2 \epsilon^{\left(-\frac{a}{2} - j\sqrt{b - \frac{a^2}{4}}\right)x}$$

$$= \epsilon^{-\frac{ax}{2}} [C_1 \epsilon^{j\alpha x} + C_2 \epsilon^{-j\alpha x}] \text{ where } \alpha = \sqrt{b - \frac{a^2}{4}}.$$

But

$$\begin{aligned} e^{j\alpha x} &= \cos \alpha x + j \sin \alpha x \\ \therefore C_1 e^{j\alpha x} &= C_1 \cos \alpha x + C_1 j \sin \alpha x \\ e^{-j\alpha x} &= \cos \alpha x - j \sin \alpha x \\ \therefore C_2 e^{-j\alpha x} &= C_2 \cos \alpha x - C_2 j \sin \alpha x \end{aligned}$$

$$y = \epsilon^{-\frac{ax}{2}} [(C_1 + C_2) + \cos \alpha x (C_1 - C_2) \sin \alpha x j].$$

In order that y shall be real it is necessary that $C_1 + C_2$ and $j(C_1 - C_2)$ shall be real, in other words, $C_1 - C_2$ must be imaginary.

Let

$$A = C_1 + C_2 \text{ and } B = j(C_1 - C_2)$$

$$y = \epsilon^{-\frac{ax}{2}} [A \cos \alpha x + B \sin \alpha x] \quad (38)$$

$$= C_1 \epsilon^{-\frac{ax}{2}} \sin(\alpha x + C_2) \quad (39)$$

where

$$C_1 = \sqrt{A^2 + B^2}$$

and

$$\tan C_2 = \frac{A}{B}.$$

(c) the square root is zero, that is $\frac{a^2}{4} = b$, or $m_1 = m_2$

$$\therefore X y = C_1 \epsilon^{m_1 x} + C_2 \epsilon^{m_2 x} = \epsilon^{m_1 x} (C_1 + C_2) = C \epsilon^{m_1 x}$$

This is not a complete solution of the complementary function because we have only one integration constant.

The equation can obviously be written.

$$\begin{aligned} (D - m_1)^2 y &= 0 \\ &= (D - m_1)(D - m_1)y = 0 \end{aligned} \quad (40)$$

Let

$$(D - m_1)y = v \quad (41)$$

Then 40 becomes

$$(D - m_1)v = 0$$

or

$$\frac{dv}{dx} - m_1 v = 0$$

$$v = C_1 \epsilon^{m_1 x}.$$

From (41)

$$(D - m_1)y = C_1\epsilon^{m_1x}$$

or

$$\frac{dy}{dx} - m_1y = C_1\epsilon^{m_1x}$$

$$y = \epsilon^{m_1x} [\int \epsilon^{-m_1x} C_1\epsilon^{m_1x} dx + C_2]$$

or

$$y = \epsilon^{m_1x} [C_1x + C_2] \tag{42}$$

Two Coils Having Resistance, Self-inductance and Imperfect Mutual Inductance Constant Impressed e.m.f.—Let the constant e.m.f. impressed on the first coil be E and that on the second coil E_1 . Let their resistances and inductances be respectively r , r_1 and L , L_1 and let $M < LL_1$.

It follows that

$$E = ri + L \frac{di}{dt} + M \frac{di_1}{dt} \tag{43}$$

and

$$E_1 = i_1r_1 + L_1 \frac{di_1}{dt} + M \frac{di}{dt} \tag{44}$$

Differentiate (44).

$$\therefore 0 = r_1 \frac{di_1}{dt} + L_1 \frac{d^2i_1}{dt^2} + M \frac{d^2i}{dt^2} \tag{45}$$

From (43) is found

$$\frac{di_1}{dt} = \frac{1}{M} \left(E - ir - L \frac{di}{dt} \right) \tag{46}$$

$$\therefore \frac{d^2i_1}{dt^2} = -\frac{1}{M} \left(r \frac{di}{dt} + L \frac{d^2i}{dt^2} \right) \tag{47}$$

Substitute (46) and (47) in (45) and arrange the equation with reference to the derivatives.

$$\therefore \frac{d^2i}{dt^2} (LL_1 - M^2) + \frac{di}{dt} (L_1r + Lr_1) + irr_1 = Er_1 \tag{48}$$

Or

$$\begin{aligned} \frac{d^2i}{dt^2} + \left[\frac{L_1r + Lr_1}{LL_1 - M^2} \right] \frac{di}{dt} + \frac{rr_1}{LL_1 - M^2} \\ = \frac{Er_1}{LL_1 - M^2} \end{aligned} \tag{49}$$

$$\therefore i = \frac{E}{r} + A_1\epsilon^{m_1t} + A_2\epsilon^{m_2t} \tag{50}$$

Similarly

$$i_1 = \frac{E_1}{r_1} + B_1\epsilon^{m_1t} + B_2\epsilon^{m_2t} \tag{51}$$

where m_1 and m_2 are the roots of the equation.

$$m^2 + \frac{L_1 r + L r_1}{LL_1 - M^2} m + \frac{rr_1}{LL_1 - M^2} = 0 \quad (52)$$

$$m = - \frac{(L_1 r + L r_1) \mp \sqrt{(L_1 r - L r_1)^2 + 4M^2 r r_1}}{2(LL_1 - M^2)} \quad (53)$$

It is evident, from the factors under the square root sign, that in this case the two roots are real.

Thus the solution is

$$m_1 = - \frac{L_1 r + L r_1 - \sqrt{(L_1 r - L r_1)^2 + 4M^2 r r_1}}{2(LL_1 - M^2)} \quad (54)$$

and

$$m_2 = - \frac{L_1 r + L r_1 + \sqrt{(L_1 r - L r_1)^2 + 4M^2 r r_1}}{2(LL_1 - M^2)} \quad (55)$$

The integration constants A_1 , A_2 and B_1 , B_2 are readily determined, since in this case (where the mutual inductance is not perfect) currents can not flow without producing some flux, and thus, since the establishment of flux requires time, the currents can not appear instantaneously.

Therefore at $t = 0$, $i = i_1 = 0$.

Referring to (50) and denoting the final current

$$\left(\text{where } I = \frac{E}{r} \right) \quad (56)$$

by $0 = I + A_1 + A_2$, or $A_2 = -(A_1 + I)$

we get $i = I + A_1 \epsilon^{m_1 t} - (A_1 + I) \epsilon^{m_2 t}$ (57)

and $i_1 = I_1 + B_1 \epsilon^{m_1 t} - (B_1 + I_1) \epsilon^{m_2 t}$ (58)

These equations still contain the two unknown quantities A_2 and B_2 . To determine them, multiply (43) by L_1 and (44) by $-M$.

$$L_1 E = L_1 i r + LL_1 \frac{di}{dt} + L_1 M \frac{di_1}{dt} \quad (59)$$

$$-ME_1 = -Mi_1 r_1 - ML_1 \frac{di_1}{dt} - M_2 \frac{di}{dt} \quad (60)$$

$$\therefore L_1 E - ME_1 = L_1 i r - Mi_1 r_1 + (LL_1 - M^2) \frac{di}{dt}$$

$$\therefore i_1 = \frac{1}{Mr_1} \left[L_1 i r + ME_1 - L_1 E + \frac{di}{dt} (LL_1 - M^2) \right] \quad (61)$$

The value of $\frac{di}{dt}$ is found by differentiating (57) and the value of

i directly from equation (57). Substituting these values in (61) and remembering that for $t = 0$, $i_1 = 0$, the integration constant A_1 is found to be:

$$A_1 = \frac{L_1 E - M E_1 + m_2 I (L L_1 - M^2)}{(m_1 - m_2) (L L_1 - M^2)} \quad (62)$$

$$\therefore A_2 = - (A_1 + I) \quad (63)$$

Similarly
$$B_1 = \frac{L E_1 - M E + m_2 I_1 (L L_1 - M^2)}{(m_1 - m_2) (L L_1 - M^2)} \quad (64)$$

$$B_2 = - (B_1 + I_1) \quad (65)$$

The equations of the currents are found by substituting these constants in equations (57) and (58). They are so long and cumbersome, however, that it seems unnecessary to insert them in this text.

Assume that the two coils are identical and wound in the same direction, and are connected across the same constant potential busbars. What are the equations of the currents?

m_1 and m_2 are found from equations (54) and (55).

$$m_1 = - \frac{r}{L + M} \quad (66)$$

$$m_2 = - \frac{r}{L - M} \quad (67)$$

$A_1 = B_1$ is found from equation (62) by substituting these values.

$$A_1 = B_1 = - \frac{E}{r} = - I$$

thus $A_2 = B_2 = 0$.

Referring to equation (57):

$$i = i_1 = \frac{E}{r} \left[1 - \epsilon^{-\frac{r}{L+M} t} \right] \quad (68)$$

This shows that the mutual inductance acts as self-inductance.

It is also evident that if the two coils are wound in opposite directions the circuit is almost non-inductive. It would be non-inductive if $M = L$; that is, with perfect mutual inductance. It is of particular interest to study the relations of the currents in two such identical windings inductively related when one is supplied with current from a source of constant potential and the other is short-circuited.

It is well to deduce the equations from the two general expressions:

$$E = ir + L \frac{di}{dt} + M \frac{di_1}{dt}$$

and

$$0 = i_1 r_1 + L_1 \frac{di_1}{dt} + M \frac{di}{dt}$$

However, it is evident that having once determined the general equations (57), (58), (62), (63), (64) and (65), it is possible to give the equations for the case in consideration by putting $E_1 = 0$;

that is,
$$I_1 = \frac{E_1}{r_1} = 0$$

$$i = I + A_1 \epsilon^{m_1 t} - (A_1 + I) \epsilon^{m_2 t} \quad (69)$$

and
$$i_1 = B_1 \epsilon^{m_1 t} - B_1 \epsilon^{m_2 t} = B_1 (\epsilon^{m_1 t} - \epsilon^{m_2 t}) \quad (70)$$

Referring to equation (62) and substituting equations (66) and (67)

$$A_1 = -\frac{I}{2},$$

and

$$A_2 = -(I + A_1) = -\frac{I}{2}$$

$$\therefore i = I - \frac{I}{2} \left[\epsilon^{-\frac{r}{L+M}t} - \epsilon^{\frac{r}{L-M}t} \right] \quad (71)$$

Referring to equation (64) and making similar substitutions we get

$$B_1 = -\frac{I}{2}$$

$$\therefore i_1 = -\frac{I}{2} \left[\epsilon^{-\frac{r}{L+M}t} - \epsilon^{-\frac{t}{L-M}t} \right] \quad (72)$$

It is evident that these equations do not lend themselves to the limiting condition $M = L$, on account of the assumption made in determining the integration constants; that is, that leakage flux exists between the two coils. To get these values, equations (20) and (21) should be used.

In Fig. 20 are given some very interesting curves which show how the current in the short-circuited winding depends upon the leakage flux between the windings. These curves represent the conditions of two identical coils having a resistance of 0.10 ohm

and an inductance of 2.5 henrys, placed at various distances apart so that the mutual inductance is $M = L$ in curve *a*, $M = 0.9L$ in curve *b*, $M = 0.7L$ in curve *C*, $M = 0.5L$ in curve *d*, and $M = 0.1L$ in curve *e*.

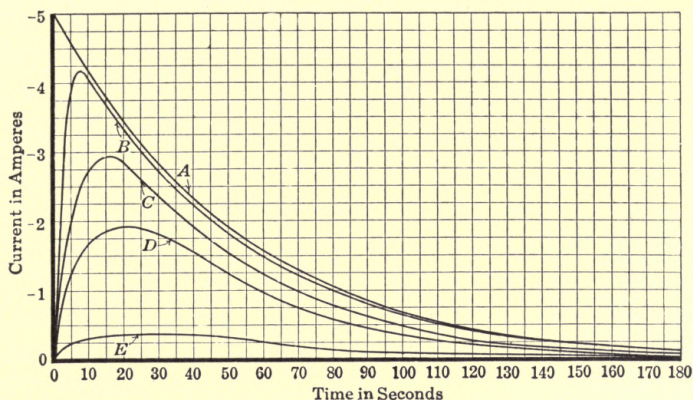

FIG. 20.

One of the coils is connected to a source of constant potential, $e = 1$ volt, while the other is short-circuited.

Prove that the time for the maximum value of the secondary current is:

$$t = \frac{L^2 - M^2}{2Mr} \log \frac{L + M}{L - M}.$$

CHAPTER III

CIRCUITS OF RESISTANCE AND VARIABLE INDUCTANCE

In the discussions given so far it has been assumed that the inductance L has been constant. In almost all cases of interest to engineers this is, however, not the case because almost all magnetic circuits contain iron, and the permeability of iron is not

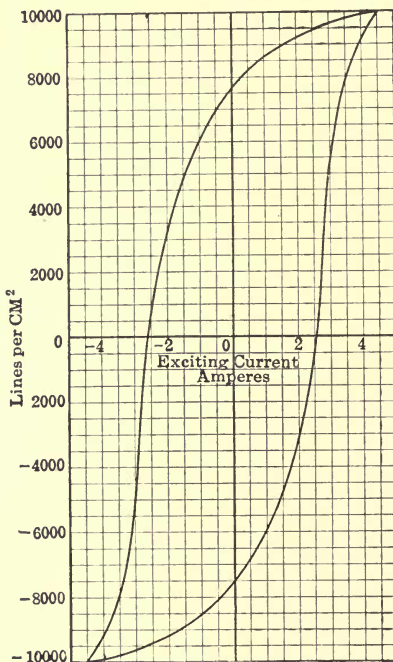

FIG. 21.

constant but depends upon the magnetization. In other words the flux produced by a given current is not proportional to the current. Fig. 21 gives the saturation curve of an entirely closed iron magnetic circuit, as shown in Fig. 22. It is the familiar hysteresis loop, which shows how the magnetism lags behind the m.m.f. producing it.

This particular sample has a remnant magnetism of 7600 lines per cm.², so that this density corresponds to an exciting current of 0 amp. The maximum density is 10,000, which corresponds to an exciting current of 4.5 amp. If, after the maximum

density is reached, the current is gradually reduced the relation between existing current and density is found in curve *a*. The flux does not disappear until the current is 2.6 amp. in opposite direction to the original 4.5 amp.

If, instead of being entirely of iron, the magnetic circuit consisted partly of air circuit and partly iron (Fig. 23), the influence of the air circuit would as a rule be so much greater than that of

the iron that the shape of the saturation curve would become materially modified. Thus the saturation curve of a dynamo, having a magnetic circuit largely of iron but also of at least a small air gap, can be represented by a set of curves similar to those in Fig. 24.

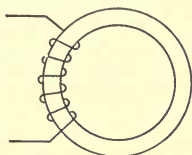

FIG. 22.

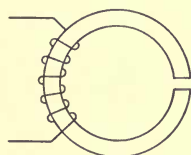

FIG. 23.

If the air circuit is very small the two curves corresponding to *a* and *b* in Fig. 21 can be observed. If the gap is reasonably large the two curves merge into one as shown in the dotted line.

FRÖLICH evolved an equation of such a saturation curve for a magnetic circuit consisting partly of iron and partly of an air gap; which, modified by KENNELLY, can be written thus

$$\phi = \frac{ki}{1 + k_1i}$$

where ϕ is the flux corresponding to an exciting current of *i* amp.

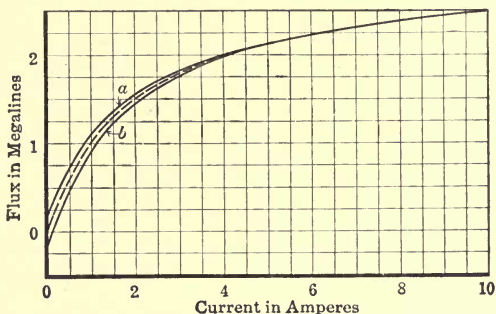

FIG. 24.

If the number of turns of the exciting winding is known then the inductance for any particular value of current *i* can be determined. It is

$$L = \frac{N\phi}{10^8i} \text{ where } N = \text{number of turns.}$$

$$\therefore L = \frac{Nk10^{-8}}{1 + k_1i}$$

The general equation thus becomes:

$$\begin{aligned} e &= ir + \frac{d}{dt}(Li) = ir + L \frac{di}{dt} + i \frac{dL}{dt} \\ &= ir + \frac{Nk10^{-8}}{1 + k_1i} \frac{di}{dt} - \frac{iNkk_110^{-8}}{(1 + k_1i)^2} \frac{di}{dt} \end{aligned} \tag{73}$$

To solve this equation the variables are separated

$$\therefore \frac{di}{(e - ir)(1 + k_1 i)^2} = \frac{10^8 dt}{Nk}$$

or

$$\int \frac{di}{(e - ir)(1 + k_1 i)^2} = \frac{10^8 t}{Nk} + C.$$

The integral is solved by breaking up the fraction $\frac{1}{(e - ir)(1 + k_1 i)^2}$ into three fractions

$$= \frac{A}{e - ir} + \frac{B}{1 + k_1 i} + \frac{C}{(1 + k_1 i)^2}.$$

The constants can be readily found and the integration carried out without the slightest difficulty.

$$A \text{ becomes } \frac{r^2}{a^2}$$

$$B \text{ becomes } \frac{k_1 r}{a^2}$$

$$\text{and } C \text{ becomes } \frac{k_1}{a}.$$

The result is:

$$t = \frac{Nk}{10^8 a} \left[\frac{r}{a} \log e \frac{(1 + k_1 i)}{e - ir} + \frac{k_1 i}{1 + k_1 i} \right]$$

where

$$a = r + ek_1.$$

In this case a simple solution which is quite accurate is obtained if the last term in (73) be omitted since an inspection will show it to be small as compared with the second term.

We have then

$$e = ir + L \frac{di}{dt} = ir + \frac{Nk10^{-8}}{1 + k_1 i} \frac{di}{dt}$$

Separating the variables we get:

$$\int \frac{di}{(e - ir)(1 + k_1 i)} = \frac{10^8 t}{Nk} + C \quad (74)$$

again

$$\begin{aligned} \frac{1}{(e - ir)(1 + k_1 i)} &= \frac{A}{e - ir} + \frac{B}{1 + k_1 i} \\ &= \frac{A + Be + i(Ak_1 - Br)}{(e - ir)(1 + k_1 i)}. \end{aligned}$$

Since the left-hand member does not contain the unknown i and since the constant term is 1, we get

$$A + Be = 1$$

$$Ak_1 = Br.$$

Thus
$$A = \frac{r}{r + ek_1} \text{ and } B = \frac{k_1}{r + ek_1}$$

The intergral is thus broken up into two simple integrals

$$\begin{aligned} \int \frac{di}{(e - ir)(1 + k_1i)} &= \int \frac{rdi}{(r + ek_1)(e - ir)} + \int \frac{k_1di}{(r + ek_1)(1 + k_1i)} \\ &= -\frac{r}{r + ek_1} \frac{1}{r} \log(e - ir) + \frac{k_1}{r + ek_1} \frac{1}{k_1} \log(1 + k_1i) \\ &= \frac{1}{r + ek_1} \log \frac{1 + k_1i}{e - ir} \\ \therefore \log \frac{1 + k_1i}{e - ir} &= (r + ek_1) \frac{10^8t}{Nk} + C. \end{aligned}$$

If it is desired to find the value of i at any time after the circuit is closed then $i = 0$ for $t = 0$

$$\therefore C = \log \frac{1}{e}$$

$$\therefore \log e \frac{(1 + k_1i)}{e - ir} = (r + ek_1) \frac{10^8t}{Nk}$$

or
$$\frac{1 + k_1i}{e - ir} = \frac{1}{e} E^{\frac{(r + ek_1) 10^8t}{Nk}} \tag{75}$$

The curve connecting i and t can conveniently be obtained by assuming different values of t and solving for the left-hand member of the equation. The value of i can then, of course, be easily determined.

Curve a in Fig. 25 shows the relation between the exciting current and the time for the field current of a direct-current generator having the following constants:

- $e = 100$ volts = voltage impressed on the field.
- $r = 100$ ohms = field resistance.
- $N = 4000$ = total number of field-turns in series.
- $\phi_1 = 1$ megaline with 1 amp. excitation.
- $\phi_2 = 0.6$ megaline with 0.5 amp. excitation.

From FRÖLICH'S equation follows then:

$$1 = \frac{k}{1 + k_1} \text{ and } 0.6 = \frac{0.5k}{1 + 0.5k_1} \therefore k = 1.5$$

$$k_1 = 0.5.$$

It is instructive to verify this curve.

Curve b gives the corresponding values if the saturation curve had been a straight line, *i.e.*, if the flux were 1 megaline for 1 amp. excitation, and 0.5 megaline for 0.5 amp. excitation.

In that case the inductance L would be constant and would be

$$L = \frac{4000 \times 1,000,000}{10^8 \times 1} = 40 \text{ henrys}$$

and the equation $e = ir + L \frac{di}{dt}$ would be $100 = 100i + 40 \frac{di}{dt}$ in which case

$$i = 1 - e^{-2.5t} \quad (76)$$

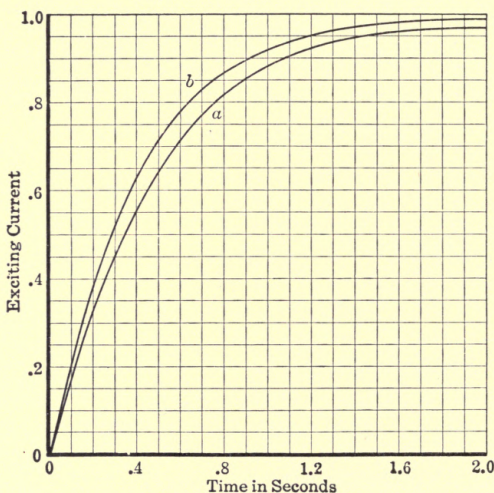

FIG. 25.

It is interesting to see that the field flux builds up considerably slower than would have been the case if L had been constant. The reason for this is that, while at the final value $i = 1$, the inductance is the same in both cases, for all smaller values of current the inductance is greater because the flux is greater for the same current. When the saturation can not be expressed by a simple equation, there is no better method than to calculate step by step.

Let Fig. 26 represent such a saturation curve. Determine the rise of current when a constant impressed e.m.f. of 100 volts is impressed on a coil 4000 turns having a resistance of 100 ohms.

Thus

$$e = ir + \frac{N}{10^8} \frac{d\phi}{dt}$$

Using differences instead of differentials:

$$e = ir + \frac{N}{10^8} \frac{\Delta\phi}{\Delta t} \tag{77}$$

or

$$\begin{aligned} \Delta\phi &= \frac{10^8 (e - ir) \Delta t}{N} \\ &= 0.25 \times 10^7 (1 - i) \Delta t \end{aligned} \tag{78}$$

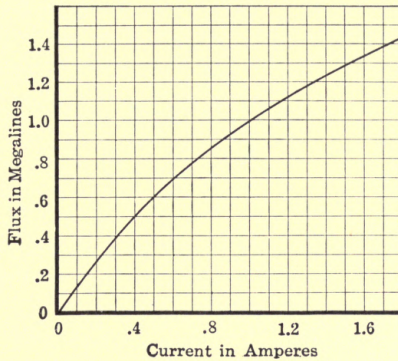

FIG. 26.

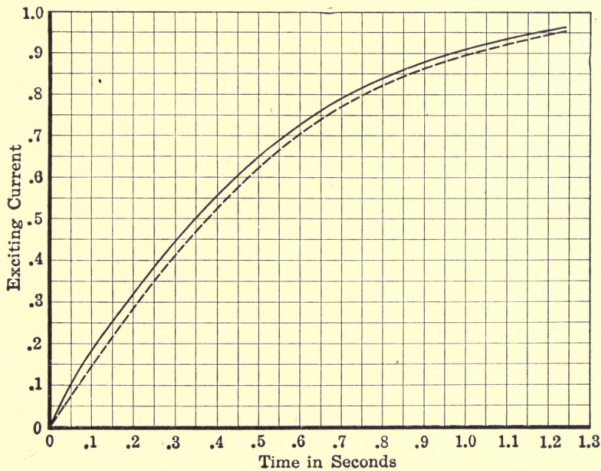

FIG. 27.

If the values of current are determined every one tenth of a second $\Delta t = 0.10$.

$$\therefore \Delta\phi = 0.25 \times 10^6 (1 - i).$$

The actual flux at any time is of course $\Sigma\Delta\phi$ the corresponding relation as obtained by the use of the differential equation.

The method of calculating is illustrated in the table given below and the results plotted in full-drawn lines in Fig. 27.

First approximation				Second approximation			
t	$\Delta\varphi$	$\Sigma\Delta\varphi$	i^1	$1 - i$	$\Delta\varphi$	$\Sigma\Delta\varphi$	i
0.10	0.25	0.25	0.182	0.818	0.205	0.205	0.146
0.20	0.205	0.41	0.316	0.684	0.171	0.376	0.286
0.30	0.171	0.547	0.447	0.553	0.138	0.514	0.413
0.40	0.138	0.652	0.555	0.445	0.111	0.625	0.525
0.50							

The starting of an alternating current in an inductive circuit containing iron is of special interest since almost all electrical devices used with alternating current have iron. Unfortunately the equations are very complex and are not subject to solution, even with long and elaborate treatment by series. Even in the simplest case, when the saturation curve can be represented by FRÖLICH'S equation, an accurate solution is not possible, although to be sure it is not difficult to bring the relation into the form of a linear differential equation. The problem in that case can be solved as far as a mathematician is interested; but the engineer, and indeed the mathematician, can not use the solution for any practical purpose.

To illustrate this assume that an alternating-current e.m.f. is impressed on a magnetic circuit having N effective turns per phase, and a saturation curve represented by $\phi = \frac{ki}{1 + k_1i}$. Assume that the resistance of the winding is r ohms, and that the impressed e.m.f. is a sine wave. At any instant the following relation exists:

$$E \sin \omega t = ir + L \frac{di}{dt} + i \frac{dL}{dt}.$$

But $L = \frac{N\phi}{10^8i}$ where N = number of turns,

¹ i is read off the saturation curve or since in this particular case a saturation curve which can be expressed by FRÖLICH'S equation has been assumed for the relation $i = \frac{\varphi}{1.5 - 0.5\varphi} = \frac{1.5}{1 + 0.5i}$

again neglecting the last term.

$$\begin{aligned} \therefore E \sin \omega t &= ir + \frac{Nk10^{-8}}{1 + k_1 i} \frac{di}{dt} \\ &= ir + \frac{a}{1 + k_1 i} \frac{di}{dt} \end{aligned} \tag{79}$$

where $a = Nk 10^{-8}$

substituting for $1 + k_1 i = \frac{1}{y}$;

$$\therefore i = \frac{1}{k_1} \left(\frac{1}{y} - 1 \right) \tag{80}$$

$$\frac{di}{dt} = - \frac{1}{k_1 y^2} \frac{dy}{dt}$$

$$\begin{aligned} \therefore E \sin \omega t &= \frac{1 - y}{yk_1} r - \frac{ay}{k_1 y^2} \frac{dy}{dt} \\ &= \frac{r}{k_1 y} - \frac{r}{k_1} - \frac{a}{k_1 y} \frac{dy}{dt} \end{aligned}$$

$$k_1 y E \sin \omega t = r - ry - a \frac{dy}{dt}$$

$$\frac{dy}{dt} + y \frac{(r + k_1 E \sin \omega t)}{a} = \frac{r}{a} \tag{81}$$

$$y = \epsilon^{-\int \frac{r + k_1 E \sin \omega t}{a} dt}$$

$$\left[\frac{r}{a} \int \epsilon^{+\int \frac{r + k_1 E \sin \omega t}{a} dt} dt + c \right] \tag{82}$$

Since $i = \frac{1}{k_1} \left(\frac{1}{y} - 1 \right)$

the solution for i is found by a simple substitution.

Unfortunately, however, the solution is not in a simple form and can not be simplified; and thus, while mathematically the problem is solved, practically it is unsolved. In cases like this it is necessary to proceed by a step-by-step method.

Consider then the case of an alternating-current impressed upon a magnetic structure having a saturation curve of any shape. Let it, for instance, be expressed by

$$\phi = \frac{ki}{1 + k_1 i}$$

The following relation exists at any instant:

$$E \sin \omega t = ir + \frac{N}{10^8} \frac{d\phi}{dt} \tag{83}$$

where r is the resistance

$$\therefore E \sin \omega t dt = ir dt + \frac{N}{10^8} d\phi \quad (84)$$

$$\therefore d\phi = \frac{E \times 10^8}{N} \sin \omega t dt - \frac{ir \cdot 10^8}{N} dt \quad (85)$$

If, with full-load effective current I_e the resistance drop is p per cent. of the rated voltage, then

$$I_e r = \frac{p}{100} \frac{E}{\sqrt{2}}, \text{ and for any other value of } I \text{ as } i, ir = \frac{p}{100 I_e} \frac{iE}{\sqrt{2}} \quad (86)$$

$$\therefore d\phi = \frac{E \times 10^8}{N} \left[\sin \omega t dt - \frac{i}{I_e} \frac{p}{100 \sqrt{2}} dt \right]$$

or since

$$d \frac{\cos \omega t}{\omega} = - \sin \omega t dt$$

$$d\phi = \frac{E \times 10^8}{N} \left[- d \frac{\cos \omega t}{\omega} - \frac{pi dt}{100 I_e \sqrt{2}} \right].$$

It is usually more convenient in alternating-current problems to introduce θ , the phase angle, instead of ωt .

In that case $\theta = \omega t$ and $dt = \frac{d\theta}{\omega}$.

Referring to (127)

$$\begin{aligned} d\phi &= \frac{E \times 10^8}{N} \left[\frac{\sin \theta d\theta}{\omega} - \frac{pi d\theta}{I_e 100 \sqrt{2} \omega} \right] \\ &= \frac{E \times 10^8}{N \omega} \left[\sin \theta d\theta - \frac{pi d\theta}{I_e 100 \sqrt{2}} \right] \\ &= - \frac{E \times 10^8}{N \omega} \left[d \cos \theta + \frac{pi}{I_e 100 \sqrt{2}} d\theta \right] \quad (87) \end{aligned}$$

In most problems E , N , Φ_{max} and the frequency are known, so that numerical values can directly be substituted in the above equation. Since, however, there is a relation between them, one or more of the quantities may be unknown.

The most general aspect of the problem is given by eliminating the numerical value of the impressed voltage, turns and frequency, and specifying the maximum value of the flux: ϕ maximum = Φ .

We have the following well-known relation between Φ , N , E and ω .

$$E = \frac{2\pi f \Phi N}{10^8} = \frac{\Phi \omega N}{10^8}$$

$$\therefore \Phi = \frac{E \cdot 10^8}{\omega N} \quad (88)$$

When in an inductive circuit the resistance is very small compared with the reactance so that the impressed and counter e.m.f. are equal numerically.

Substituting this value in (87)

$$d\phi = -\Phi \left[d \cos \theta + \frac{pi}{I_e 100 \sqrt{2}} d\theta \right].$$

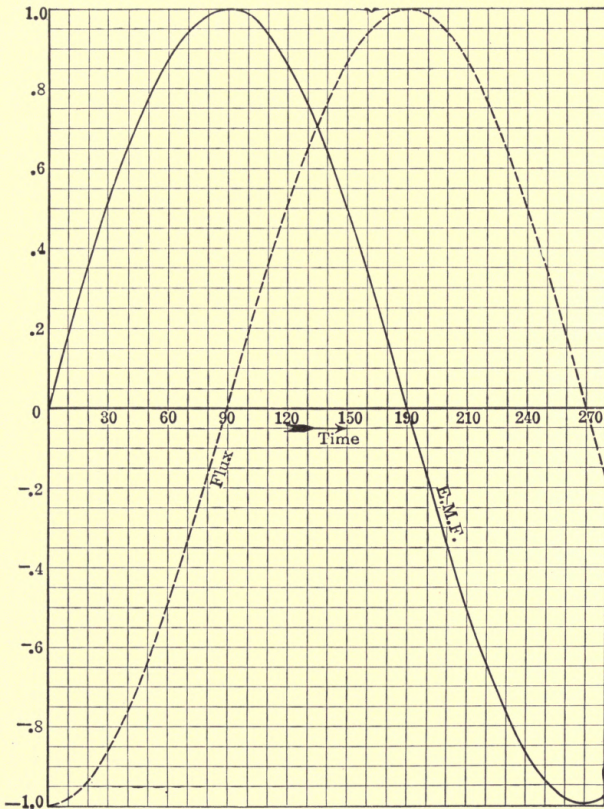

FIG. 28.

Substituting differences

$\Delta\phi$, $\Delta \cos \theta$ and $\Delta\theta$ instead of differentials, the equation becomes:

$$\Delta\phi = -\Phi \left[\Delta \cos \theta + \frac{pi}{I_e 100 \sqrt{2}} \Delta\theta \right].$$

If the ratio between flux, current and phase angle θ is determined every 10° then $\Delta\theta = 10^\circ = 0.175$ radians.

$$\therefore \Delta\phi = -\Phi \left[\Delta \cos \theta + 0.00124 p \frac{i}{I_e} \right]$$

Numerical Example.—Determine by “step-by-step” method the current in an iron-clad inductive circuit when an alternating-current e.m.f. is impressed thereon. Assume that the saturation

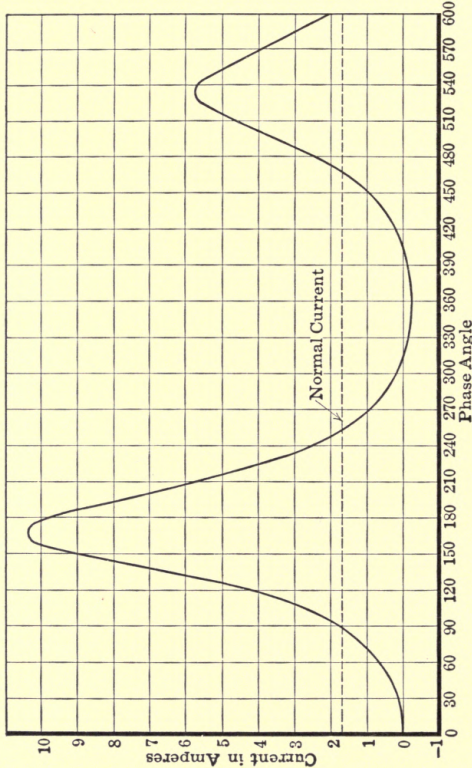

FIG. 29

curve of the magnetic circuit is represented by Fig. 26 and equation:

$$\phi = \frac{1.5i}{1 + 0.5i} \text{ megalines.}$$

Assume that before the switch is closed the remanent magnetism is zero as is practically the case when the magnetic circuit contains an air gap. Assume further that under normal conditions

CIRCUITS OF RESISTANCE AND INDUCTANCE 67

of operation the maximum flux is 1.4 megalines, that normal effective current is 1.7 amp., and that the resistance drop is 3.91 per cent. Then

$$\begin{aligned} \Delta\phi &= -1.4 [\Delta \cos \theta + 0.00286i] \\ &= -1.4 \Delta \cos \theta - 0.004i \end{aligned}$$

The total flux is obviously $\Sigma\Delta\phi$. If the switch is closed when the e.m.f. passes through zero and is rising, the normal flux at that instant would be a maximum in the negative direction as shown in Fig. 29. As it has been assumed that the flux really is zero it is evident that there is a transient stage in the magnetization before permanent condition is reached. It is evident also that if the switch were closed when the e.m.f. was a maximum no transient condition would result, because the condition then demands zero flux, and the flux is assumed to be zero. In the numerical example it is assumed that the switch is closed when the e.m.f. wave passes through zero.

The method of using the above equation is best shown by the table given below.

No. 1	No. 2	No. 3	No. 4	No. 5	No. 6	No. 7	No. 8	No. 9
θ	$\cos \theta$	$\Delta \cos \theta$	$-1.4 \Delta \cos \theta$	$\Sigma\Delta\phi$	i	$0.004i$	$\Sigma\Delta\phi$	i
0	1.0	0	0	0	0	0	0	0
10	0.98	-0.02	0.028	0.028	0.01884	0.000075	0.027925	0.01875
20	0.94	-0.04	0.056	0.0839	0.0576	0.00023	0.08367	0.0573
30	0.87	-0.07	0.098	0.18167	0.1289	0.000516	0.1811	0.1288
40	0.77	-0.10	0.14	0.32115	0.2398	0.000959	0.3202	0.2395
50	0.64	-0.13	0.182	0.5020	0.402	0.001608	0.5004	0.4010
60	0.50	-0.14	0.196	0.6960	0.604	0.002416	0.6935	0.6020
70	0.34	-0.16	0.224	0.9175	0.881	0.00352	0.9139	0.8740
80	0.17	-0.17	0.238	1.1519	1.247	0.00497	1.1469	1.238
90	0.00	-0.17	0.238	1.385	1.712	0.00684	1.3781	1.699

Column No. 1, phase angle; No. 2, the cosine of the phase angle; No. 3, difference in the value of the cosine between two successive steps, for instance $\cos 20^\circ - \cos 10^\circ$; No. 4 is self-explanatory; No. 5, first approximation of the flux (sum of No. 8 of the preceding line and No. 4 on the line under consideration); No. 6, current as obtained from the saturation curve or the equation if such is given; No. 7, ohmic drop; No. 8, second approximation to the flux which takes into consideration the ohmic drop (the algebraic sum of No. 5 and No. 7); No. 9, current corresponding to the last approximation of the flux column, No. 8.

CHAPTER IV

CHARACTERISTICS OF CONDENSERS

The charge q of a condenser is proportional to the voltage; or $q = Ce$, where C is the capacity the value of which depends upon the mechanical construction, dimensions, etc., of the condenser, and e is the voltage.

The charge q is expressed in coulombs or ampere-seconds. Thus the charge dq given in a time dt when the current is i amp. is:

$$dq = idt.$$

The capacity is expressed in farads, a very large unit; so large indeed that in actual practice it is never used. The capacities of condensers are almost always given in microfarads, that is, in a unit which is one-millionth of a farad. Nevertheless, in all formulæ involving capacity, C stands for farads, not microfarads (m-f.) unless stated to the contrary.

To give an idea of the capacity of condensers used in engineering, it may be of interest to know that the ordinary paraffine paper and tinfoil 500-volt blocks of the size of the average text-book have a capacity from 1 to 2 m-f. In a high-potential transmission line the capacity of one wire against neutral is about 0.016 m-f. per mile. The capacity of underground cables is relatively high. Depending upon the voltage and type of cable, etc., it must obviously vary much. It is usually less than 2 m-f. per mile and more than $\frac{1}{10}$ m-f. The capacity of an ordinary Leyden jar is extremely small—a very small fraction of a microfarad.

The fundamental equations for the condenser are as stated above

$$q = Ce \tag{1}$$

and
$$dq = idt \tag{2}$$

From these follow:
$$e = \frac{q}{C} \tag{3}$$

$$dq = Cde \tag{4}$$

and
$$i = \frac{dq}{dt} \tag{5}$$

Substituting (4) in (2)

$$Cde = idt \text{ or } i = C \frac{de}{dt} \tag{6}$$

or e , the voltage across the condenser = $\frac{1}{C} \int idt$ (7)

The rate of energy supply or power is ei
or from (6),

$$ei = e \frac{Cde}{dt} = Ce \frac{de}{dt} \tag{8}$$

or from (3) and (9), $ei = \frac{q}{C} i = \frac{q}{C} \frac{dq}{dt}$ (9)

The energy stored in a condenser, which is the same as that required to charge a condenser to a voltage E or to a final charge Q , is therefore the rate of energy multiplied by the time. It is:

$$\int_0^E Ce \frac{de}{dt} dt = C \int_0^E e \frac{ed}{dt} dt = C \left| \frac{e^2}{2} \right|_0^E = \frac{CE^2}{2} \tag{10}$$

or $\int_0^Q \frac{q}{C} \frac{dq}{dt} dt = \frac{1}{C} \int_0^Q q \frac{dq}{dt} dt = \frac{1}{C} \left| \frac{q^2}{2} \right|_0^Q = \frac{Q^2}{2C}$ (11)

Equations (10) and (11) are obviously identical, since at any instant

$$q = Ce \text{ thus for } e = E \text{ when } q = Q$$

$Q = CE$, which, substituted in (11), gives

$$\frac{C^2E^2}{2C} = \frac{CE^2}{2}$$

As in the case of inductance, the calculation of the capacity of any but the simplest circuits is difficult. It will be dealt with in later chapters.

Of particular interest to engineers, however, are a few simple forms of condensers, the approximate capacity of which are given by equations which are well known.

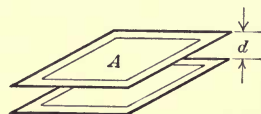

FIG. 30.

Thus the capacity between parallel plates, Fig. 30 is:

$$C = \frac{KA}{11.3d \times 10^8}, \text{ in microfarads}$$

where K , the specific inductive capacity is approximately 1 for air, 2 for paraffin paper, 3 for rubber, 5 for mica and 6 for glass.

A , the effective area is given in sq. cm. and d , the thickness of the dielectric, in centimeters.

The capacity between concentric conductors (Fig. 31) is:

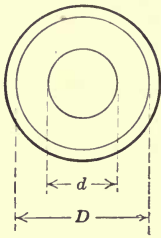

FIG. 31.

$$C = \frac{0.0386lK}{\log_{10} \frac{D}{d}}, \text{ in microfarads}$$

where the length l is given in miles of cable, K is the specific inductive capacity, D the inside diameter of the outside conductor, and d the diameter of the inside conductor. This is the capacity between the conductors, not the capacity to neutral or ground. The capacity of one conductor 1 mile long to neutral is twice as great.

The capacity between transmission lines is:

$$C = \frac{0.0386l}{\log_{10} \frac{D}{r}}, \text{ in microfarads}$$

where l is expressed in miles and the capacity is that of one line against neutral. D is the distance between wires, center to center, and r the radius of wire. The charging current is thus

$$i_c = \frac{2\pi f C e}{10^6}$$

where e is one-half of the line voltage in the single-phase system and 58 per cent. thereof in the three-phase system.

Circuits Containing Concentrated Capacity and Resistance

Consider at first the case of a constant e.m.f. E impressed upon a circuit of resistance r and capacity C , Fig. 32. After the circuit is established a current flows and energy is delivered to the resistance and the condenser. In the resistance heat is developed and in the condenser an electrostatic field is produced.

The energy given by the source of supply of power is $\int E i dt$. The energy supplied to the resistance is

$$\int i^2 r dt$$

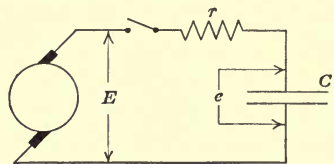

FIG. 32.

and the energy supplied to the condenser

$$\int q \frac{dq}{C} dt$$

Thus

$$\int E i dt = \int i^2 r dt + \int q \frac{dq}{C} \quad (12)$$

or

$$E i dt = i^2 r dt + q \frac{dq}{C}$$

or

$$E i = i^2 r + \frac{q}{C} \frac{dq}{dt} \text{ which is the power equation} \quad (13)$$

and

$$E = i r + \frac{q}{C} \frac{dq}{dt}$$

or substituting for $dq = i dt$

$$E = i r + \frac{q}{C} \text{ which is the voltage equation} \quad (14)$$

Obviously the voltage equation could have been derived directly, since $i r$ is the e.m.f. consumed by the resistance and $\frac{q}{C}$ the voltage across the condenser.

The condenser voltage is thus $e_1 = E - i r$; but

$$i = C \frac{de_1}{dt} \therefore e_1 = E - Cr \frac{de_1}{dt}$$

or

$$\frac{de_1}{dt} + \frac{1}{Cr} e_1 = \frac{E}{Cr}$$

Referring to equation (14) $e_1 = A \epsilon^{-\frac{1}{Cr} t} + E$ (15)

where A is the integration constant: The current is readily found, since $i = C \frac{de_1}{dt}$

$$\therefore i = -\frac{CA}{Cr} \epsilon^{-\frac{1}{Cr} t} = -\frac{A}{r} \epsilon^{-\frac{1}{Cr} t} \quad (16)$$

The charge q is $= C e_1 = CA \epsilon^{-\frac{1}{Cr} t} + EC$. (17)

Special cases:

(a) Condenser charge.

At time $t = 0$, $e_1 = 0$.

\therefore referring to equation (15), $0 = A + E \therefore A = -E$

$$\therefore e_1 = E \left[1 - \epsilon^{-\frac{1}{Cr} t} \right] \quad (18)$$

Referring to equation (16)

$$i = \frac{E}{r} \epsilon^{-\frac{1}{Cr} t} \quad (19)$$

Referring to equation (17)

$$q = EC \left[1 - \epsilon^{-\frac{1}{Cr}t} \right] \tag{20}$$

(b) Condenser discharge.

In this case the impressed voltage $E = 0$ for $t = 0$, $e_1 = e_0$. Referring to equation (15)

$$e_1 = A \epsilon^{-\frac{1}{Cr}t} \text{ and } e_0 = A$$

$$\therefore e_1 = e_0 \epsilon^{-\frac{1}{Cr}t} \tag{21}$$

$i = -\frac{e_0}{r} \epsilon^{-\frac{1}{Cr}t}$ that is in opposite direction to charging current (22)

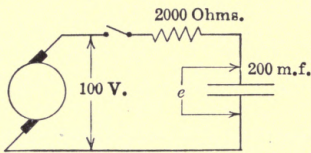

FIG. 33.

$$q = Ce_0 \epsilon^{-\frac{1}{Cr}t} \tag{23}$$

Referring to the e.m.f. of the condenser rather than to the impressed e.m.f., the current becomes positive since the discharge current

$$i = -\frac{dq}{dt} = -C \frac{de_1}{dt} \tag{24}$$

$$\therefore i = \frac{Ce_0}{Cr} \epsilon^{-\frac{1}{Cr}t} = \frac{e_0}{r} \epsilon^{-\frac{1}{Cr}t} \tag{25}$$

In order fully to understand the action of condensers it is not sufficient to follow the equations given above, but it is essential and indeed necessary to figure a number of numerical examples.

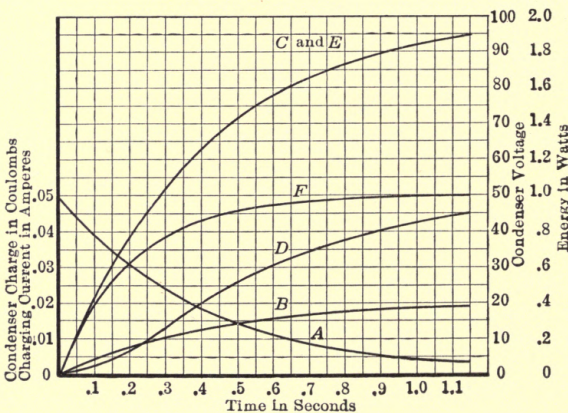

FIG. 34.

For this reason Figs. 33 and 34 are given. The curves shown there should be checked numerically by every student. They

are calculated under the assumption that a constant impressed e.m.f. of 100 volts is impressed on a circuit of 2000 ohms resistance and 200 m-f. capacity, as shown in Fig. 33.

An interesting problem in connection with the charging and discharging of condensers, is to consider the flow of current between two Leyden jars of different capacity and voltage (Fig. 35). The energy stored in condenser *A* at voltage *E* is $\frac{1}{2}CE^2$. The energy stored in condenser *A* at voltage *e* is $\frac{1}{2}Ce^2$. The energy stored in condenser *B* at voltage E_1 is $\frac{1}{2}C_1E_1^2$. The energy stored in condenser *B* at voltage e_1 is $\frac{1}{2}C_1e_1^2$. While current flows between the two condensers, a readjustment of energy takes place.

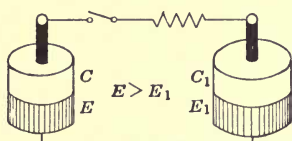

FIG. 35.

The energy equation is obviously:

$$0.5CE^2 + 0.5C_1E_1^2 - 0.5Ce^2 - 0.5C_1e_1^2 = \int i^2 r dt.$$

By differentiating this equation, the following results:

$$- Cede - C_1e_1de_1 = i^2 r dt \tag{26}$$

As it is assumed that the voltage of *A* is higher than that of *B*, the latter being charged; thus

$$i = C_1 \frac{de_1}{dt} \tag{27}$$

where e_1 is the voltage of *B* at any time. Equation (26) contains three variables, *e*, e_1 , and *i*, which, however, are dependent upon each other.

At any instant the following relation exists between the e.m.fs.

$$e = ir + e_1$$

Thus
$$\frac{de}{dt} = r \frac{di}{dt} + \frac{de_1}{dt} = rC_1 \frac{d^2e_1}{dt^2} + \frac{de_1}{dt}$$

Substituting in (26)

$$- C \left(C_1 r \frac{de_1}{dt} + e_1 \right) \left(C_1 r \frac{d^2e_1}{dt^2} + \frac{de_1}{dt} \right) - C_1 e_1 \frac{de_1}{dt} = C_1^2 r \left(\frac{de_1}{dt} \right)^2 \tag{28}$$

or

$$- C \left(C_1 r \frac{de_1}{dt} + e_1 \right) \left(C_1 r \frac{d^2e_1}{dt^2} + \frac{de_1}{dt} \right) - C_1 \frac{de_1}{dt} \left(C_1 r \frac{de_1}{dt} + e_1 \right) = 0$$

or

$$- \left(C_1 r \frac{de_1}{dt} + e_1 \right) \left(C_1 \frac{de_1}{dt} + C C_1 r \frac{d^2e_1}{dt^2} + C \frac{de_1}{dt} \right) = 0$$

Since $C_{1r} \frac{de_1}{dt} + e_1$ can not be zero

$$C_1 \frac{de_1}{dt} + CC_{1r} \frac{d^2e_1}{dt^2} + C \frac{de_1}{dt} = 0 \quad (29)$$

Integrating (157)

$$C_1 e_1 + CC_{1r} \frac{de_1}{dt} + C e_1 = K$$

or
$$\frac{de_1}{dt} + e_1 \frac{C + C_1}{CC_{1r}} = \frac{K}{CC_{1r}} = K_1 \quad (30)$$

Thus
$$e_1 = K_1 + K_2 \epsilon^{-\frac{1}{C_{or}}t} \quad (31)$$

where

$$C_0 = \frac{CC_1}{C + C_1} \quad (32)$$

The integration constants K_1 and K_2 are determined from the initial condition that for $t = 0$, $e_1 = E_1$ and $e = E$

$$\therefore E_1 = K_1 + K_2 \text{ or } K_2 = E_1 - K_1$$

$$\therefore e_1 = K_1 + (E_1 - K_1) \epsilon^{-\frac{1}{C_{or}}t}$$

$$\therefore e_1 = E_1 + \frac{C}{C + C_1} (E - E_1) \left[1 - \epsilon^{-\frac{1}{C_{or}}t} \right] \quad (33)$$

$$i = C_1 \frac{de_1}{dt} = \frac{C(E - E_1)}{C_{or}} \epsilon^{-\frac{1}{C_{or}}t} \quad (34)$$

but

$$e = ir + e_1$$

$$\therefore e = -\frac{C_1}{C_0} (E_1 - K_1) \epsilon^{-\frac{1}{C_{or}}t} + K_1 + (E_1 - K_1) \epsilon^{-\frac{1}{C_{or}}t}$$

for

$$t = 0 \quad e = E$$

$$\therefore E = -\frac{C_1}{C_0} (E_1 - K_1) + K_1 + E_1 - K_1$$

$$\therefore K_1 = E_1 + \frac{C_0}{C} (E - E_1)$$

and

$$K_2 = -\frac{C_0}{C_1} (E - E_1)$$

$$\therefore e = E - \frac{C_1}{C + C_1} (E - E_1) \left[1 - \epsilon^{-\frac{1}{C_{or}}t} \right] \quad (35)$$

The problem can be solved in a simpler way if it is realized that the total charge in the system is not changed after the switch is closed. Thus

$$Q_0 = EC + E_1 C_1 = q + q_1 \quad (36)$$

Where q and q_1 are the charges at any time in jars A and B respectively.

In that case $e = ir + e_1$; or since $q = eC$ and $q_1 = e_1C_1$,

$$\frac{q}{C} = ir + \frac{q_1}{C_1} = ir + \frac{Q_0}{C_1} - \frac{q}{C_1}.$$

Assuming $E > E_1$, then jar A is being discharged thus

$$i = - \frac{dq}{dt}$$

$$\therefore \frac{q}{C} = - \frac{rdq}{dt} + \frac{Q_0}{C_1} - \frac{q}{C_1}$$

or

$$\frac{dq}{dt} + \frac{C + C_1}{CC_1r}q = \frac{Q_0}{C_1r}$$

$$\therefore q = \frac{Q_0C}{C + C_1} + K\epsilon^{-\frac{1}{C_0r}t}$$

where

$$C_0 = \frac{CC_1}{C + C_1}$$

for

$$t = 0, \quad q = EC$$

$$\therefore EC = \frac{Q_0C}{C + C_1} + K.$$

Since condenser B is being charged

$$i = + C_1 \frac{de_1}{dt}$$

$$\therefore i = - \frac{C_1}{C_0r}(E_1 - K)\epsilon^{-\frac{1}{C_0r}t}$$

or

$$K = EC - \frac{Q_0C}{C + C_1} = C_0(E - E_1)$$

$$q = \frac{Q_0C}{C + C_1} + C_0(E - E_1)\epsilon^{-\frac{1}{C_0r}t}.$$

Since condenser A is being discharged

$$i = - \frac{dq}{dt} = + \frac{E - E_1}{r}\epsilon^{-\frac{1}{C_0r}t}.$$

The voltage across condenser A , which is being discharged is

$$\begin{aligned} e &= - \frac{1}{C} \int idt = + \frac{1}{C} \left(\frac{E - E_1}{r} \right) C_0r\epsilon^{-\frac{1}{C_0r}t} + K_1 \\ &= \frac{C_1}{C - C_1} (E - E_1)\epsilon^{-\frac{1}{C_0r}t} + K_1 \end{aligned}$$

for

$$t = 0 \quad e = E$$

$$\therefore K_1 = E - \frac{C_1}{C + C_1} (E - E_1)$$

$$\therefore e = E - \frac{C_1}{C + C_1}(E - E_1) \left[1 - \epsilon^{-\frac{1}{C_0 r} t} \right]$$

$$q_1 = Q_0 - q = Q_0 - \frac{Q_0 C}{C + C_1} - C_0(E - E_1)\epsilon^{-\frac{1}{C_0 r} t}$$

$$= \frac{Q_0 C_1}{C + C_1} - C_0(E - E_1)\epsilon^{-\frac{1}{C_0 r} t}$$

$$e_1 = \frac{1}{C_1} \int idt = -\frac{1}{C_1} \frac{E - E_1}{r} C_0 r \epsilon^{-\frac{1}{C_0 r} t} + K_2$$

$$= -\frac{C}{C + C_1}(E - E_1)\epsilon^{-\frac{1}{C_0 r} t} + K_2$$

for $t = 0, e_1 = E_1$

$$\therefore K_2 = E_1 + \frac{C}{C + C_1}(E - E_1)$$

and $e_1 = E + \frac{C}{C + C_1}(E - E_1) - \frac{C}{C + C_1}(E - E_1)\epsilon^{-\frac{1}{C_0 r} t}$

$$e_1 = E_1 + \frac{C}{C + C_1}(E - E_1) \left[1 - \epsilon^{-\frac{1}{C_0 r} t} \right]$$

With a slight modification of this equation it is seen that for $t = \infty$ the final voltage between the coatings of the Leyden jars is

$$E_f = \frac{Q_0}{C + C_1}$$

Numerical example: condenser *A* has a capacity of 1 m.f. and is charged to 1000 volts; condenser *B* has a capacity of 2 m.f. and is charged to 500 volts; the resistance is 10,000 ohms. Find the current after the switch is closed.

The original charge in *A* is then $1000 \times \frac{1}{10^6} = 0.001$ coulomb; the charge in *B* is $\frac{500 \times 2}{10^6} = 0.001$ coulomb also.

$$E - E_1 = 500$$

$$C_0 = \frac{2 \times 10^6}{3 \times 10^{12}} = \frac{2}{3 \times 10^6}$$

and $\frac{1}{C_0 r} = 150$

$$C + C_1 = 3 \times 10^{-6} \frac{C_1}{C + C_1} = 0.667 \frac{C}{C + C_1} = 0.333$$

$$\therefore i = \frac{500}{10,000} \epsilon^{-150t} = 0.05 \epsilon^{-150t}$$

$$\begin{aligned}
 e &= 1000 - 0.667 \times 500(1 - e^{-150t}) \\
 &= 500[2 - 0.667(1 - e^{-150t})] \\
 e_1 &= 500 + 0.333 \times 500(1 - e^{-150t}) \\
 &= 500[1 + 0.333(1 - e^{-150t})].
 \end{aligned}$$

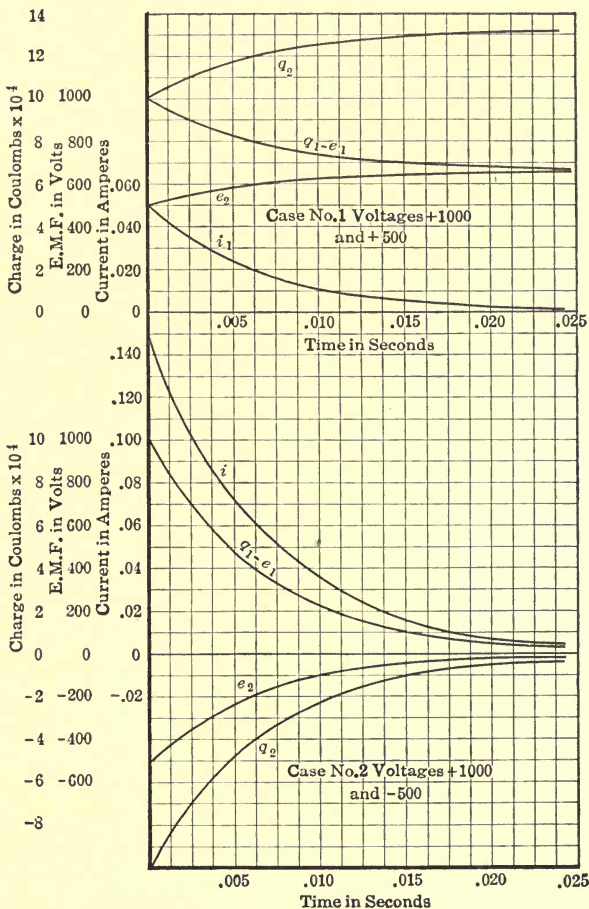

FIG. 36.

For $t = \infty$, $e_0 = e_{01} = 0.667$ volts which is the final voltage of the two jars.

Fig. 36 gives the result of these calculations.

Harmonic E.m.f. Impressed upon a Circuit of Resistance and Capacity in Series.—Let $e = E \sin \omega t$ be the impressed e.m.f., r the resistance, C the capacity and q the charge at any instant.

Then, referring to Fig. 37,

$$E \sin \omega t = ir + \frac{q}{C} = ir + \frac{1}{C} \int idt \quad (1)$$

Differentiating

$$E\omega \cos \omega t = r \frac{di}{dt} + \frac{i}{C}$$

$$\therefore \frac{di}{dt} + \frac{i}{Cr} = \frac{E\omega \cos \omega t}{r}$$

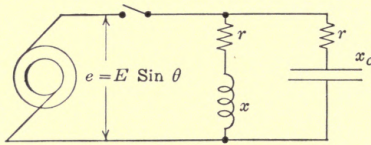

FIG. 37.

Thus,

$$i = \epsilon^{-\frac{1}{Cr}t} \left[\int \epsilon^{+\frac{1}{Cr}t} \frac{E\omega}{r} \cos \omega t dt + K \right] \quad (2)$$

The integration is readily made and the result is:

$$i = \frac{E}{Z} \sin (\omega t + \beta) + K \epsilon^{-\frac{1}{Cr}t} \quad (3)$$

where

$$Z = \sqrt{r^2 + x_c^2} = \sqrt{r^2 + \frac{1}{\omega^2 C^2}}$$

and

$$\tan \beta = \frac{x_c}{r}.$$

The voltage across the condenser is:

$$e_c = \frac{1}{C} \int idt = \frac{1}{C} \int \frac{E}{Z} \sin (\omega t + \beta) dt + \frac{K}{C} \int \epsilon^{-\frac{1}{Cr}t} dt$$

$$= -\frac{E}{C\omega Z} \cos (\omega t + \beta) - rK \epsilon^{-\frac{1}{Cr}t}.$$

At the moment of closing the switch $e_c = 0$.

Thus for $t = t_1$, $e_c = 0$.

$$\therefore K = -\frac{Ex_c}{rZ} - \frac{1}{Cr t_1} \cos (\omega t_1 + \beta)$$

thus,

$$i = \frac{E}{Z} \left[\sin (\omega t + \beta) - \frac{x_c}{r} \epsilon^{-\frac{1}{Cr}(t-t_1)} \cos (\omega t_1 + \beta) \right] \quad (4)$$

or

$$i = \frac{E}{Z} \left[\sin (\theta + \beta) - \frac{x_c}{r} \epsilon^{-\frac{x_c}{r}(\theta-\theta_1)} \cos (\theta_1 + \beta) \right] \quad (5)$$

As an interesting application of these equations and the corresponding equation for inductive circuits, consider the nature of the current supplied to a tuned circuit, Fig. 37, when the resistance is small.

$$x = -x_c, Z = \sqrt{r^2 + x^2} = \sqrt{r^2 + x_c^2}$$

The line current at any time is the sum of the currents in the two circuits.

$$\therefore i_0 = \frac{E}{Z} \left[\sin(\theta - \beta) + \sin(\theta + \beta) - \epsilon^{-\frac{r}{x}(\theta - \theta_1)} \sin(\theta_1 - \beta) - \frac{x_c}{r} \epsilon^{-\frac{x_c}{r}(\theta - \theta_1)} \sin(\theta_1 + \beta) \right] \quad (6)$$

$$= \frac{E}{Z} \left[2 \sin \theta \cos \beta - \epsilon^{-\frac{r}{x}(\theta - \theta_1)} \cos(\theta_1 - \beta) - \frac{x_c}{r} \epsilon^{-\frac{x_c}{r}(\theta - \theta_1)} \cos(\theta_1 + \beta) \right] \quad (7)$$

The line current is a combination of a sine wave of form $\frac{2E \cos \beta}{Z} \sin \theta$ and two exponential or logarithmic curves. Since r is small compared with x or x_c , one of the logarithmic curves $\epsilon^{-\frac{r}{x}(\theta - \theta_1)} \sin(\theta_1 - \beta)$ dies down at a slow rate, whereas the other $\frac{x_c}{r} \epsilon^{-\frac{x_c}{r}(\theta - \theta_1)} \cos(\theta_1 + \beta)$ dies down with *extreme rapidity*.

In the limiting case when $\frac{x}{r}$ is large and β therefore approaches 90° the permanent term disappears since $\cos \beta = 0$,

$$\text{and} \quad 0 = \frac{E}{Z} \left[\epsilon^{-\frac{r}{x}(\theta - \theta_1)} \cos \theta_1 + \frac{x_c}{r} \epsilon^{-\frac{x_c}{r}(\theta - \theta_2)} \sin \theta_1 \right]$$

$$\text{for} \quad r = 0, i_0 = \frac{E}{x} \cos \theta_1$$

Thus the interesting situation occurs that if an alternating voltage is impressed on a tuned circuit as shown in Fig. 37 and if the resistance is zero the line current is a steady unidirectional current having the value:

$$i = \frac{E \cos \theta_1}{x}$$

If the switch is closed when $\theta_1 = 0$, then the direct current is a maximum and is $\frac{E}{x}$. At any other time it has a smaller value.

In Fig. 38 is shown a series of curves which illustrate this in the case where the resistance is considerable and the circuit is closed when $\theta_1 = 0$. The constants for the circuit are:

$$E = 1, r = 0.05, x = x_c = 1$$

i_0 is the total line current, the dotted sine wave is the impressed e.m.f., i_A the current in the condenser circuit, and i_B the current in the inductive circuit. As is seen, i_0 is a unidirectional current

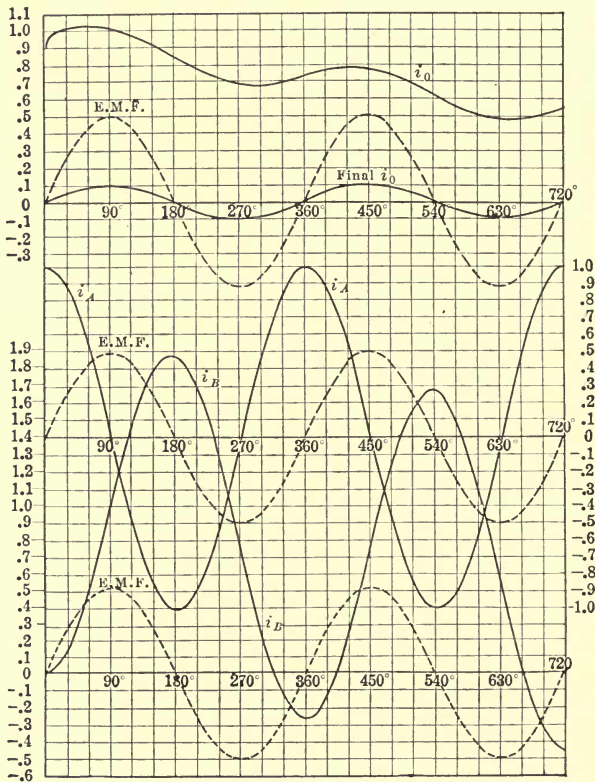

FIG. 38.

of slight pulsation, slowly decreasing in magnitude. After a number of cycles it would become a small alternating current, as shown in the curve marked Final i_0 .

This feature of a tuned circuit might be of practical importance in connection with problems of rectification—charging of storage batteries from an alternator by occasional interruption of the

current and starting it at the time when normal current in either branch would be a maximum.

Circuits of Inductance and Capacity.—While practically such circuits can never exist they offer much interest from a theoretical point of view since their study represents an introduction to oscillating circuits, which are of much importance in electrical engineering.

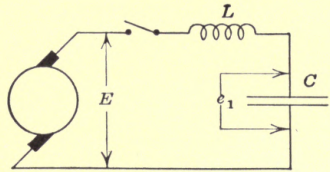

FIG. 39.

In Fig. 39 is shown such a circuit. In practice the condition there indicated is approached when a very low resistance overhead transmission line supplies power to a cable net work, which

case, however, is fully treated in a subsequent chapter.

The following relation exists at any time.

$$E = L \frac{di}{dt} + e_1$$

where E is the instantaneous value of the impressed voltage and e_1 the voltage across the condenser.

But
$$i = C \frac{de_1}{dt}$$

thus
$$\frac{di}{dt} = C \frac{d^2e_1}{dt^2}$$

thus
$$LC \frac{d^2e_1}{dt^2} + e_1 = E$$

or
$$\frac{d^2e_1}{dt^2} + \frac{e_1}{CL} = \frac{E}{CL}$$

The solution of this equation has been given, it is:

$$e_1 = E + A_1 \epsilon^{m_1 t} + A_2 \epsilon^{m_2 t}$$

m_1 and m_2 are the roots of equation;

$$m^2 + \frac{1}{CL} = 0$$

or
$$m_1 = +j \sqrt{\frac{1}{CL}}$$

$$m = \pm j \sqrt{\frac{1}{CL}}$$

or

$$m_2 = -j\sqrt{\frac{1}{CL}}$$

$$\therefore e_1 = E + A_1\epsilon^{+jt\sqrt{\frac{1}{CL}}} + A_2\epsilon^{-jt\sqrt{\frac{1}{CL}}}$$

But

$$\epsilon^{jat} = \cos at + j \sin at$$

$$\epsilon^{-jat} = \cos at - j \sin at$$

$$\begin{aligned} \therefore A_1\epsilon^{+jt\sqrt{\frac{1}{CL}}} + A_2\epsilon^{-jt\sqrt{\frac{1}{CL}}} &= (A_1 + A_2) \cos at \\ &+ j \sin at(A_1 - A_2) \\ &= A_0 \cos at + B_0 \sin at = A \sin (at + B) \end{aligned}$$

$$\therefore e_1 = E + A \sin \left(\frac{t}{\sqrt{CL}} + B \right)$$

where A and B are integration constants.

The current

$$i = C \frac{de_1}{dt} = \frac{AC}{\sqrt{CL}} \cos \left(\frac{t}{\sqrt{CL}} + B \right) = A\sqrt{\frac{C}{L}} \left(\cos \frac{t}{\sqrt{CL}} + B \right)$$

The integration constants are determined from the knowledge of the initial conditions.

Assume for instance that it is desired to know the current and the voltage across the condenser at any instant after the switch is closed:

At the time $t = 0$, $i = 0$ and $e_1 = 0$;

$$\therefore 0 = E + A \sin B$$

and

$$0 = A \sqrt{\frac{C}{L}} \cos B.$$

Thus $\cos B$ must be: 0

$$\therefore B = \frac{\pi}{2} \text{ thus } \sin B = 1 \text{ and } A = -E$$

$$\therefore e_1 = E \left[1 - \sin \left(\frac{t}{\sqrt{CL}} + \frac{\pi}{2} \right) \right] = E \left[1 - \cos \frac{t}{\sqrt{CL}} \right]$$

and

$$i = E\sqrt{\frac{C}{L}} \sin \frac{t}{\sqrt{CL}}$$

The voltage across the reactance is $L \frac{di}{dt}$ it is

$$e^1 = LE \sqrt{\frac{C}{L}} \frac{1}{\sqrt{CL}} \cos \frac{t}{\sqrt{CL}} = E \cos \frac{t}{\sqrt{CL}}$$

In Fig. 40 are shown the voltages across the condenser and inductance as a function of time. It is seen that there is no time at which the voltage across the inductance is greater than the impressed voltage and it is also seen

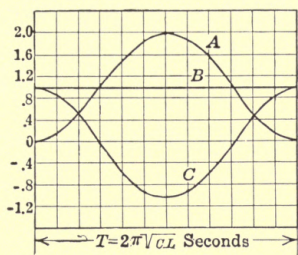

FIG. 40.

that at the instant of the first half period the voltage across the condenser is twice as great as the impressed. Thus the condenser will be subjected to double voltage during each cycle.

The maximum value of the current is, as seen;

$$i_{max} = E \sqrt{\frac{C}{L}}$$

The frequency of the alternating current $f = \frac{1}{2\pi\sqrt{LC}}$ is called the natural frequency.¹ It is almost always much higher than the frequencies used in commercial alternating-current circuits.

The Discharge of a Condenser through an Inductance.—Referring to Fig. 41. Let E_0 be the voltage of the condenser before the circuit is closed and i the current at any instant after the switch is closed.

Then

$$e_0 = L \frac{di}{dt}$$

But the discharge current

$$i = -C \frac{de_0}{dt}$$

thus

$$L \frac{di}{dt} = -CL \frac{d^2e_0}{dt^2}$$

and

$$e_0 = -CL \frac{d^2e_0}{dt^2}$$

or

$$\frac{d^2e_0}{dt^2} + \frac{1}{CL} e_0 = 0$$

$$\therefore e_0 = A_1 \epsilon^{m_1 t} + A_2 \epsilon^{m_2 t}$$

the auxiliary equation becomes:

$$m^2 + \frac{1}{CL} = 0 \text{ or } m = \pm j \sqrt{\frac{1}{CL}}$$

¹ In case of a transmission line the natural frequency will be shown to

be: $f = \frac{1}{4\sqrt{LC}}$

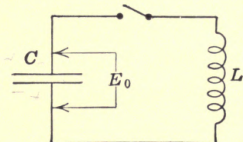

FIG. 41.

thus

$$e_0 = A \sin \left(\frac{t}{\sqrt{CL}} + B \right)$$

and

$$i = -C \frac{de_0}{dt} = -\frac{CA}{\sqrt{CL}} \cos \left(\frac{t}{\sqrt{CL}} + B \right) = -A \sqrt{\frac{C}{L}} \cos \left(\frac{t}{\sqrt{CL}} + B \right).$$

The integration constants A and B are determined from the fact that at $t = 0$, $i = 0$, and $e_0 = E_0$. Thus:

$$E_0 = A \sin B$$

$$0 = -A \sqrt{\frac{C}{L}} \cos B$$

$$\therefore \cos B = 0 \text{ and } B = \frac{\pi}{2}$$

$$\therefore \sin B = 1 \text{ and } A = E_0$$

$$\therefore e_0 = E_0 \sin \left(\frac{t}{\sqrt{LC}} + \frac{\pi}{2} \right) = E_0 \cos \frac{t}{\sqrt{LC}}$$

and

$$i = E_0 \sqrt{\frac{C}{L}} \cos \left(\frac{t}{\sqrt{LC}} + \frac{\pi}{2} \right) = E_0 \sqrt{\frac{C}{L}} \sin \frac{t}{\sqrt{LC}}$$

It is seen that the discharge frequency is the same as the frequency at charge, and that the maximum value of the current is $E_0 \sqrt{\frac{C}{L}}$.

As another application of this will be considered the condition

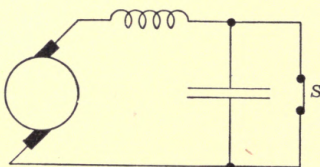

FIG. 42.

when a short-circuit is suddenly opened and the large current instantly interrupted.

This condition is diagrammatically illustrated in Fig. 42. S represents a switch which short-circuits the condenser and is

opened at the instant under consideration. (In practice this switch may represent a short-circuit across the cables opened by the magnetic effects of the current.) The current I in the short-circuit is evidently the same as the current in the inductance; therefore the energy stored in the magnetic field is $0.5LI^2$.

At any time after the switch is opened the current i flowing through the condenser, inductance and generator (all assumed as

having zero resistance) is governed by the condition that the energy stored in the condenser and inductance is the same as the original energy.

$$\therefore 0.5Li^2 + 0.5Ce^2 = 0.5LI^2$$

$$LI^2 - Li^2 = Ce^2$$

but

$$i = C \frac{de}{dt}$$

thus

$$i^2 = C^2 \left(\frac{de}{dt}\right)^2$$

$$\therefore LI^2 - LC^2 \left(\frac{de}{dt}\right)^2 = Ce^2.$$

Differentiating

$$-2LC^2 \frac{d^2e}{dt^2} \frac{de}{dt} = 2Ce \frac{de}{dt}$$

$$\therefore \frac{d^2e}{dt^2} + \frac{1}{CL} e = 0$$

and

$$e = A \sin \left(\frac{t}{\sqrt{CL}} + B \right)$$

$$i = C \frac{de}{dt} = \frac{CA}{\sqrt{CL}} \cos \left(\frac{t}{\sqrt{CL}} + B \right) = A \sqrt{\frac{C}{L}} \cos \left(\frac{t}{\sqrt{CL}} + B \right)$$

for

$$t = 0, i = I, e = 0$$

Thus

$$0 = A \sin B; \text{ and } \sin B = 0, \text{ and } B = 0$$

$$I = A \sqrt{\frac{C}{L}} \quad \therefore A = I \sqrt{\frac{L}{C}}$$

$$\therefore e = I \sqrt{\frac{L}{C}} \sin \frac{t}{\sqrt{LC}}$$

$$i = I \cos \frac{t}{\sqrt{LC}}$$

It is interesting to note that while at the instant of opening the switch, or the short-circuit, the voltage e across the condenser is zero, one-quarter of a period later (period being here the natural period which is extremely short) the voltage is a maximum and is

$$e_{max} = I \sqrt{\frac{L}{C}}$$

These equations are instructive in that they show that the maximum voltage obtained in opening a short-circuit in a cable

or transmission line is independent of the length of the line and depends only upon the constants of the circuit per unit length and the current at the time the circuit is interrupted.

They also show that when the circuit is closed on a transmission line of considerable inductance and capacity, the maximum rush of current is also independent of the length of the line and depends only upon the value of the e.m.f. and the circuit constants.

Harmonic E.m.f. Impressed upon a Circuit of Inductance and Capacity but Negligible Resistance.—This strictly theoretical condition is chosen for two reasons. The solution of the equations introduces some mathematical operations which have hitherto not been considered and the problem from the electrical point of view illuminates in a relatively simple way what happens in the extreme case in switching high-potential circuits.

The general equation obviously becomes:

$$E \sin \omega t = e_1 + L \frac{di}{dt} \quad (1)$$

where e_1 is the voltage across the condenser, Fig. 43.

But

$$i = C \frac{de_1}{dt} \quad \text{thus} \quad L \frac{di}{dt} = CL \frac{d^2e_1}{dt^2}$$

$$\therefore E \sin \omega t = CL \frac{d^2e_1}{dt^2} + e_1$$

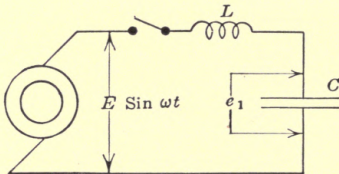

FIG. 43.

or

$$\frac{d^2e_1}{dt^2} + \frac{e_1}{CL} = \frac{E}{CL} \sin \omega t \quad (2)$$

It is seen that the right-hand member of the equation is a function of t . To solve such equation the solution of the complementary function is first found; that is, zero is substituted for the right-hand member:

$$\therefore \frac{d^2e_1}{dt^2} + \frac{e_1}{CL} = 0 \quad (3)$$

$$\therefore m^2 + \frac{1}{CL} = 0 \quad \text{or} \quad m = \pm j \sqrt{\frac{1}{CL}}$$

$$\therefore e_1 = A_1 \epsilon^{+j\sqrt{\frac{1}{CL}}t} + A_2 \epsilon^{-j\sqrt{\frac{1}{CL}}t} = A_1 \epsilon^{j\alpha t} + A_2 \epsilon^{-j\alpha t} \quad (4)$$

where

$$\alpha = \frac{1}{\sqrt{CL}}$$

The equation, as has been shown previously, can be written

$$e_1 = A \sin (\alpha t + B)$$

Thus the complementary function is

$$e_0 = A \sin (\alpha t + B) \quad \text{+} \quad (5)$$

The next step is to eliminate the sine function from the general equation (2) by two successive differentiations:

$$\begin{aligned} \frac{d^3 e_1}{dt^3} + \alpha^2 \frac{de_1}{dt} &= E \alpha^2 \omega \cos \omega t \\ \frac{d^4 e_1}{dt^4} + \alpha^2 \frac{d^2 e_1}{dt^2} &= - E \alpha^2 \omega^2 \sin \omega t \end{aligned} \quad (6)$$

Substituting the value of $E \alpha^2 \sin \omega t$ from equation (2) and arranging the equation in the order of the derivatives:

$$\frac{d^4 e_1}{dt^4} + (\alpha^2 + \omega^2) \frac{d^2 e_1}{dt^2} + \omega^2 \alpha^2 e_1 = 0 \quad (7)$$

The complete solution of (7) is obtained in the usual way:

$$\begin{aligned} m^4 + (\alpha^2 + \omega^2)m^2 + \omega^2 \alpha^2 &= 0 \\ m^2(m^2 + \alpha^2) + \omega^2(m^2 + \alpha^2) &= 0 \end{aligned}$$

or

$$\begin{aligned} (m^2 + \omega^2) (m^2 + \alpha^2) &= 0 \\ \therefore m &= \pm j\omega \\ m &= \pm j\alpha \end{aligned}$$

Thus
$$e_1 = A_1 \sin (\omega t + B_1) + A_2 \sin (\alpha t + B_2) \quad (8)$$

By referring to (5) it is evident that A_2 and B_2 must be the same as A and B .

Thus
$$e_1 = e_0 + A_1 \sin (\omega t + B_1)$$

The integration constants A_1 and B_1 are determined from the fact that the expression $A_1 \sin (\omega t + B_1)$ must be a particular solution of (2).

Thus
$$\begin{aligned} e_1 &= A_1 \sin (\omega t + B_1) \\ \frac{de_1}{dt} &= A_1 \omega \cos (\omega t + B_1) \\ \frac{d^2 e_1}{dt^2} &= - A_1 \omega^2 \sin (\omega t + B_1) \end{aligned}$$

Substituting these values in (2).

Thus

$$-A_1\omega^2 \sin(\omega t + B_1) + A_1\alpha^2 \sin(\omega t + B_1) = E\alpha^2 \sin \omega t \quad (9)$$

or
$$A_1(\alpha^2 - \omega^2) \sin(\omega t + B_1) = E\alpha^2 \sin \omega t.$$

Thus equating the coefficients of similar terms:

$$E\alpha^2 = A_1(\alpha^2 - \omega^2)$$

or
$$A_1 = \frac{E\alpha^2}{\alpha^2 - \omega^2} = \frac{Ex_c}{x_c - x} \quad (10)$$

and
$$B_1 = 0 \therefore \text{from (8)} \quad (11)$$

$$e_1 = \frac{Ex_c}{x_c - x} \sin \omega t + A \sin(\alpha t + B) \quad (12)$$

The second term in this equation may in this case be more advantageously written:

$$A_0 \sin \alpha t + B_0 \cos \alpha t$$

$$\therefore e_1 = \frac{Ex_c}{x_c - x} \sin \omega t + A_0 \sin \alpha t + B_0 \cos \alpha t \quad (13)$$

$$= Ix_c \sin \omega t + A_0 \sin \alpha t + B_0 \cos \alpha t \quad (14)$$

Where I is the maximum value of the permanent current, that is,

$$I = \frac{E}{x_c - x} \quad (15)$$

$$i = C \frac{de_1}{dt} = Ix_c\omega \cos \omega t + A_0\alpha \cos \alpha t - B_0\alpha \sin \alpha t \quad (16)$$

Considering the problem of starting a current in such a circuit: when $t = t_1$, $i = 0$ and $e_1 = 0$. If these values are substituted in equations (13) and (16) it is readily found that

$$B_0 = Ix_c \left[\frac{\omega}{\alpha} \sin \alpha t_1 \cos \omega t_1 - \sin \alpha t_1 \cos \alpha t_1 \right] \quad (17)$$

and
$$A_0 = -Ix_c \left[\sin \alpha t_1 \sin \omega t_1 + \frac{\omega}{\alpha} \cos \alpha t_1 \cos \omega t_1 \right] \quad (18)$$

Substituting these values in the equations for the current and e.m.f. across the condenser we find:

$$e_1 = \frac{Ex_c}{x_c - x} \left[\sin \omega t - \frac{\omega}{\alpha} \cos \omega t_1 \sin \alpha(t - t_1) - \sin \omega t_1 \cos \alpha(t - t_1) \right] \quad (19)$$

and

$$i = C \frac{de_1}{dt} = \frac{E}{x_c - x} \left[\cos \omega t - \cos \omega t_1 \cos \alpha(t - t_1) + x_c \sqrt{\frac{C}{L}} \sin \omega t_1 \sin \alpha(t - t_1) \right] \quad (20)$$

While as a rule equations of the form given in (2) having a sine function or exponential function on the right-hand member, can be solved by the method given above, it may be opportune here to call attention to another well-known method of more general application.

The differential equation is:

$$\frac{d^2e_1}{dt^2} + e_1\alpha^2 = E\alpha^2 \sin \omega t$$

This expression is given in symbolic factors as follows:

$$(D - m_1)(D - m_2)e_1 = E\alpha^2 \sin \omega t \quad (21)$$

where D is an abbreviation of $\frac{d}{dt}$ and m_1 and m_2 are the roots of the complementary function

$$\begin{aligned} \frac{d^2e_1}{dt^2} + e_1\alpha^2 \quad \text{or} \quad m^2 + \alpha^2 &= 0 \\ \therefore m &= \pm j\alpha \quad \text{or} \quad m_1 = +j\alpha \\ &\quad \text{and} \quad m_2 = -j\alpha \end{aligned}$$

Equation 21 can thus be written

$$(D + j\alpha)(D - j\alpha)e_1 = E\alpha^2 \sin \omega t$$

Let

$$u = e_1(D - j\alpha)$$

$$\therefore (D + j\alpha)u = E\alpha^2 \sin \omega t$$

or

$$\frac{du}{dt} + j\alpha u = E\alpha^2 \sin \omega t \quad (22)$$

This is a linear differential equation of the first order and its solution is.

$$u = \epsilon^{-jat} \int \epsilon^{+jat} E\alpha^2 \sin \omega t dt + C_1 \epsilon^{-jat} \quad (23)$$

$$\int \epsilon^{jat} \sin \omega t dt = \epsilon^{jat} \left(\frac{j\alpha \sin \omega t - \omega \cos \omega t}{\omega^2 - \alpha^2} \right)$$

$$\therefore u = \frac{E\alpha^2(j\alpha \sin \omega t - \omega \cos \omega t)}{\omega^2 - \alpha^2} + C_1 \epsilon^{-jat} \quad (24)$$

Since

$$\begin{aligned}
 u &= e_1(D - j\alpha) \\
 \frac{de_1}{dt} - j\alpha e_1 &= u \\
 \therefore e_1 &= \epsilon^{+jat} \int \epsilon^{-iat} u dt \\
 &= \epsilon^{jat} \int \epsilon^{-iat} \frac{E\alpha^3}{\omega^2 - \alpha^2} (j\alpha \sin \omega t - \omega \cos \omega t) dt \\
 &\quad + \epsilon^{jat} \int \epsilon^{-iat} C_1 \epsilon^{-iat} dt + C_2 \epsilon^{jat} \quad (25)
 \end{aligned}$$

These four integrals are solved independently below:

First,

$$\begin{aligned}
 j \frac{E\alpha^3}{\omega^2 - \alpha^2} \epsilon^{jat} \int \epsilon^{-iat} \sin \omega t dt &= j \frac{E\alpha^3}{\omega^2 - \alpha^2} \epsilon^{jat} \\
 \left(\epsilon^{-iat} \frac{-j\alpha \sin \omega t - \omega \cos \omega t}{\omega^2 + \alpha^2} \right) &= -j \frac{E\alpha^3}{\omega^2 + \alpha^2} \\
 (j\alpha \sin \omega t + \omega \cos \omega t) &\quad (26)
 \end{aligned}$$

Second,

$$\begin{aligned}
 \frac{E\alpha^2\omega}{\omega^2 - \alpha^2} \epsilon^{jat} \int \epsilon^{-iat} \cos \omega t dt &= \frac{E\alpha^2\omega}{\omega^2 - \alpha^2} \epsilon^{jat} \\
 \left(\epsilon^{-iat} \frac{\omega \sin \omega t - j\alpha \cos \omega t}{\omega^2 + \alpha^2} \right) &= -j \frac{E\alpha^2\omega}{\omega^2 - \alpha^2} \\
 (\alpha \cos \omega t - j\omega \sin \omega t) &\quad (27)
 \end{aligned}$$

Third,

$$\begin{aligned}
 C_1 \epsilon^{jat} \int \epsilon^{-iat} \epsilon^{-iat} dt &= C_1 \epsilon^{-iat} \int \epsilon^{-2iat} dt = \\
 - \frac{C_1}{2j\alpha} \epsilon^{jat} \epsilon^{-2iat} &= \frac{C_1}{2j\alpha} \epsilon^{-iat} = C_3 \epsilon^{-iat} \quad (28)
 \end{aligned}$$

Fourth,

$$C_2 \epsilon^{jat} \quad (29)$$

The last two terms can be written

$$C_3 \epsilon^{-iat} + C_2 \epsilon^{jat} = C_4 \sin(\alpha t + C_5) \quad (30)$$

In the general equation it is seen that the second integral is negative thus:

$$\begin{aligned}
 e_1 &= C_4 \sin(\alpha t + C_5) + \frac{E\alpha^2}{\omega^2 - \alpha^2} \left[j\alpha\omega \cos \omega t \right. \\
 &\quad \left. + \omega^2 \sin \omega t + \alpha^2 \sin \omega t - j\alpha\omega \cos \omega t \right] \quad (31)
 \end{aligned}$$

$$\begin{aligned}
 &= C_4 \sin(\alpha t + C_5) + \frac{E\alpha^2 \sin \omega t}{\omega^2 - \alpha^2} \\
 &= C_4 \sin(\alpha t + C_5) + \frac{Ex_c}{x_c - x} \sin \omega t \quad (32)
 \end{aligned}$$

This equation is identical with (12).

As an application of these formulæ will be considered a 100-mile 60-cycle transmission line supplying power to a cable network of 50 miles. For the sake of simplicity and for the sake of later instructive comparison the resistance of the cable and of the overhead line will be neglected in this particular investigation and it will also be assumed that the inductance of the cables and the capacity of the overhead lines are so small as to be negligible when compared with the inductance of the overhead line and the capacity of the cables.

While the inductance of a line, of course, depends upon the size of the conductors and the distance between them, in reality it is not subject to a great deal of variation in ordinary lines. It is about 0.002 henrys per mile of single conductor.

The capacity of a cable system is, however, subject to great variation, depending upon the nature of the cables. Assume that in this case it is 2 m-f. per mile of single conductor, when referring to neutral voltage:

Thus $C = \frac{1}{10^4}$ farads and $L = 0.2$ henrys

$$\therefore \alpha = \frac{1}{\sqrt{LC}} = 223 \quad \sqrt{\frac{C}{L}} = 0.0223$$

$$x_c = \frac{1}{2\pi fC} = 26.4 \text{ ohms}$$

$$x = 2\pi fL = 75.4 \text{ ohms}$$

$$\omega = 2\pi f = 377.$$

If the circuit is closed when the impressed e.m.f. is zero, that is, when $t_1 = 0$, then equations 209 and 210 become:

$$e_1 = -0.54E[\sin 377t - 1.69 \sin 223t]$$

and $i = -0.0204E[\cos 377t - \cos 223t]$

The time for one complete cycle of the fundamental wave is $\frac{1}{60} = 0.0166$ sec.

If, therefore, the circuit is closed when the impressed e.m.f. is a maximum, that is, when

$$t_1 = t = 0.00416$$

then the equations become:

$$e_1 = -0.54E[\sin 377t - \cos 223(t - 0.00416)]$$

$$i = -0.0204E[\cos 377t + 0.59 \sin 223(t - 0.00416)]$$

These curves are shown in Figs. 44 and 45 when the impressed e.m.f. is 100 volts.

The curve e_1 in Fig. 44 shows the e.m.f. across the condenser, the curve i the current when the switch is closed at zero value of

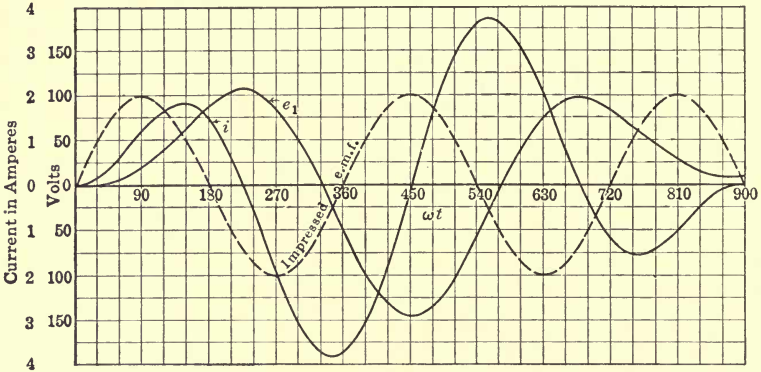

FIG. 44.

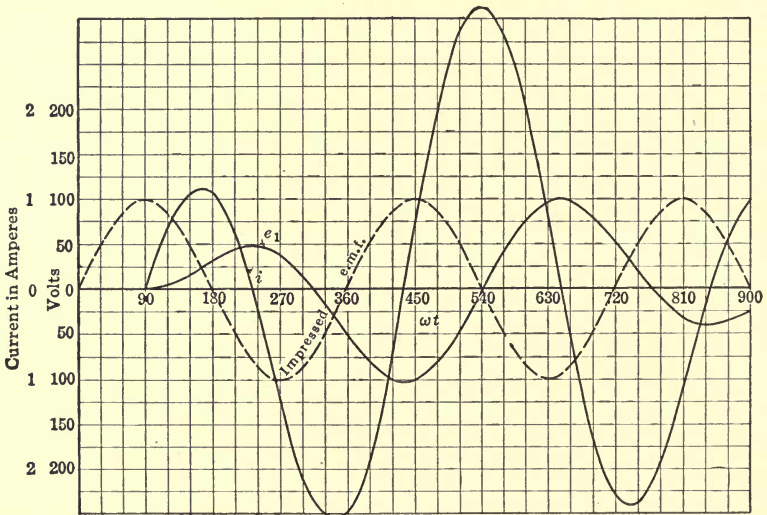

FIG. 45.

the impressed e.m.f. The corresponding lines in Fig. 45 show the same quantities when the switch is closed when the impressed e.m.f. is a maximum. In both figures the dotted sine wave is the impressed e.m.f.

Circuits Having Resistance, Inductance and Capacity. Constant Impressed E.m.f.—Let E , Fig. 46, be the constant impressed e.m.f.

r , the resistance

L , the inductance

and

C , the capacity in farads.

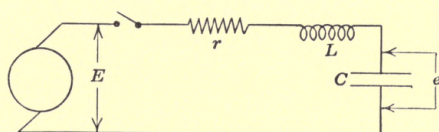

FIG. 46.

Then

$$E = ir + L \frac{di}{dt} + \frac{1}{C} \int idt.$$

Differentiating

$$0 = r \frac{di}{dt} + L \frac{d^2i}{dt^2} + \frac{i}{C}$$

or

$$\frac{d^2i}{dt^2} + \frac{r}{L} \frac{di}{dt} + \frac{i}{CL} = 0.$$

The solution of this equation has been shown previously to be:

$$i = A_1 \epsilon^{m_1 t} + A_2 \epsilon^{m_2 t}.$$

Where m_1 and m_2 are the roots of the auxiliary equation.

$$m^2 + \frac{r}{L} m + \frac{1}{CL} = 0$$

$$\therefore m_1 = -\frac{r}{2L} + \sqrt{\frac{r^2}{4L^2} - \frac{1}{CL}} = -\alpha + \beta$$

$$m_2 = -\frac{r}{2L} - \sqrt{\frac{r^2}{4L^2} - \frac{1}{CL}} = -\alpha - \beta$$

where

$$\alpha = \frac{r}{2L}$$

and

$$\beta = \sqrt{\frac{r^2}{4L^2} - \frac{1}{CL}} = \frac{1}{2L} \sqrt{r^2 - \frac{4L}{C}}$$

$$\therefore i = A_1 \epsilon^{(-\alpha + \beta)t} + A_2 \epsilon^{(-\alpha - \beta)t} = \epsilon^{-\alpha t} [A_1 \epsilon^{\beta t} + A_2 \epsilon^{-\beta t}].$$

Three conditions are possible:

- (a) $r^2 - \frac{4L}{C}$ is positive.
 (b) $r^2 - \frac{4L}{C}$ is negative.
 (c) $r^2 - \frac{4L}{C}$ is zero.

Considering first the *Case (a)*,

$$r^2 - \frac{4L}{C} \text{ (positive).}$$

Then
$$i = \epsilon^{-\alpha t} [A_1 \epsilon^{\beta t} + A_2 \epsilon^{-\beta t}].$$

The e.m.f. across the condenser is:

$$e_1 = E - ir - L \frac{di}{dt} = E - r\epsilon^{-\alpha t} [A_1 \epsilon^{\beta t} + A_2 \epsilon^{-\beta t}] - L[(\beta - \alpha) A_1 \epsilon^{(\beta - \alpha)t} - (\beta + \alpha) A_2 \epsilon^{-(\beta + \alpha)t}].$$

The integration constants for starting the current in this circuit are determined from the fact that when $t = 0$, $i = 0$ and $e_1 = 0$.

Thus

$$\begin{aligned} A_1 &= -A_2 \text{ and } A_1 = \frac{E}{2L\beta} \\ \therefore i &= \frac{E}{2L\beta} \epsilon^{-\alpha t} (\epsilon^{\beta t} - \epsilon^{-\beta t}) = \frac{E}{2L\beta} \epsilon^{-(\alpha - \beta)t} \\ &- \epsilon^{-(\alpha + \beta)t} = \frac{E}{\sqrt{r^2 - 4\frac{L}{C}}} (\epsilon^{-(\alpha - \beta)t} - \epsilon^{-(\alpha + \beta)t}) \end{aligned}$$

If

$$\sqrt{r^2 - 4\frac{L}{C}} = S,$$

then

$$i = \frac{E}{S} \left(\epsilon^{-\left(\frac{r-S}{2L}\right)t} - \epsilon^{-\left(\frac{r+S}{2L}\right)t} \right).$$

By differentiating i and substituting its value and that of i in the equation of the voltage of the condenser:

$$e_1 = E - ir - L \frac{di}{dt}$$

we get

$$e_1 = E \left[1 - \frac{1}{2S} \left((r+S)\epsilon^{-\frac{r-S}{2L}t} - (r-S)\epsilon^{-\frac{r+S}{2L}t} \right) \right].$$

The equation for the *discharge current* can readily be proven to be exactly the same as that of the initial current except for reversed sign.

During the discharge the voltage is

$$e_d = \frac{E_0}{2S} \left((r + S)\epsilon^{-\frac{r-S}{2L}t} - (r - S)\epsilon^{-\frac{r+S}{2L}t} \right)$$

where E_0 is the voltage of the condenser before the discharge.

Case (b).— $r^2 - 4\frac{L}{C}$ negative.

In this case $\sqrt{r^2 - \frac{4L}{C}}$ can be written $j\sqrt{\frac{4L}{C} - r^2}$
 $= jS_1$ where $S_1 = \sqrt{\frac{4L}{C} - r^2}$

$$\therefore i = A_1\epsilon^{m_1t} + A_2\epsilon^{m_2t} = \epsilon^{-\frac{r}{2L}t} \left(A_1\epsilon^{j\frac{S_1}{2L}t} + A_2\epsilon^{-j\frac{S_1}{2L}t} \right).$$

It has been shown previously that this equation can be written:

$$i = A\epsilon^{-\frac{r}{2L}t} \sin \left(\frac{S_1}{2L}t + B \right) \quad (1)$$

where A and B are integration constants. The e.m.f. across the condenser is

$$e_1 = E - ir - L \frac{di}{dt}.$$

Substituting the values of i and $\frac{di}{dt}$ as obtained from equation (1)

$$e_1 = E - A\epsilon^{-\frac{r}{2L}t} \left[r \sin \left(\frac{S_1}{2L}t + B \right) + \frac{LS_1}{2L} \cos \left(\frac{S_1}{2L}t + B \right) - \frac{r}{2} \sin \left(\frac{S_1}{2L}t + B \right) \right] \quad (2)$$

Counting time from the instant of closing the circuit, then for $t = 0, i = 0,$ and $e_1 = 0.$

From equation (1) it is found that $A \sin B = 0; \therefore B = 0,$ and from equation (2) $A = \frac{2E}{S_1}.$

$$\therefore i = \frac{2E}{S_1} \epsilon^{-\frac{r}{2L}t} \sin \frac{S_1 t}{2L}$$

and

$$e_c = E \left[1 - \frac{\sqrt{r^2 + S_1^2}}{S_1} \epsilon^{-\frac{r}{2L}t} \sin \left(\frac{S_1 t}{2L} + \gamma \right) \right]$$

where $\tan \gamma = \frac{S_1}{r}.$

In a similar way is found the equation for the discharge current which will be identical with the charging current, and the voltage across the condenser, $e_a = E_0\epsilon^{-\frac{r}{2L}t} \sin \left(\frac{S_1 t}{2L} + \gamma \right),$ where E_0 is the original voltage across the condenser.

Case (c).—
$$r^2 - \frac{4L}{C} = 0$$

In this case, as has been shown previously,

$$i = e^{m_1 x} (A + Bx)$$

or

$$i = \epsilon^{-\frac{r}{2L} t} (A + Bt)$$

$$e_1 = E - ir - L \frac{di}{dt}$$

$$= E - r\epsilon^{-\frac{r}{2L} t} (A + Bt) - LB\epsilon^{-\frac{r}{2L} t} + \frac{r}{2L} \epsilon^{-\frac{r}{2L} t} (A + Bt).$$

If the time is counted from the instant of closing the switch, then for $t = 0$, $i = 0$, and $e_1 = 0$

$$A = 0$$

and

$$0 = E - LB, \text{ or } B = \frac{E}{L}$$

$$\therefore i = \frac{E}{L} t \epsilon^{-\frac{r}{2L} t}$$

and

$$e_1 = E \left[1 - \epsilon^{-\frac{r}{2L} t} \left(1 + \frac{rt}{2L} \right) \right].$$

The equation for the discharge current is the same as that of the initial charging current, the voltage across the condenser during discharge being:

$$e_d = E_0 \left(1 + \frac{rt}{2L} \right) \epsilon^{-\frac{r}{2L} t}.$$

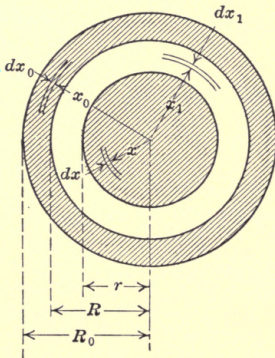

FIG. 47.

As an application of these equations will be considered the case of starting a direct current at 500 volts in a 20-mile concentric cable having the dimensions given in Fig. 47.

In this instance it will be assumed that the capacity of the line can be represented as that of a condenser at the end of the line taking one-half of the charging current.

It will be assumed that the specific inductive capacity is 3, the diameter of the inside conductor 0.5 in., the

diameter of the outside conductor 0.7 in., and the outside diameter 0.86 in. The resistance of the 20 miles of cable is 8.8 ohms.

The capacity per mile of concentric cable previously given is

$$Cmf = \frac{0.0386K}{^{10}\log \frac{D}{d}} = 0.795 \text{ m-f. per mile.}$$

Thus the capacity of the 20 miles of cable is 15.9 m-f. and the equivalent capacity at the end of the line is 7.95 m-f., or 7.95 by 10^{-6} farads.

Since the determination of the inductance of a concentric cable involves the general method applied to other systems, it will be given below, although such determinations do not come within the scope of this treatise.

The inductance is recollected to be numerically equal to the interlinkages of the turns and flux per unit current.

In general if the m.m.f. acting in a circuit is M then the flux produced is $\frac{4\pi M \times \text{area of magnetic circuit}}{\text{length of magnetic circuit}}$. The interlinkage factor is that fraction of the total current which is enclosed by the flux and

$$L = \frac{1}{I} \Sigma \text{ flux} \times \text{turns} \times \text{interlinkage factor.}$$

Consider first the flux in the inside conductor due to the assumed uniform distribution of the current.

At a distance x from the center see Fig. 47, the m.m.f. is $\frac{\pi x^2}{\pi r^2} I$ where I is the total current. The area of the flux per centimeter of length of conductor is dx and the length of the magnetic circuit is $2\pi x$.

$$\therefore d\phi_1 = 4\pi \frac{x^2}{r^2} I \frac{dx}{2\pi x} = 2I \frac{x}{r^2} dx$$

This flux interlinks with $\frac{\pi x^2}{\pi r^2}$ of the total current, and hence the interlinkage factor is $\frac{x^2}{r^2}$.

$$\therefore L_1 = \frac{1}{I} \int_0^r 2I \frac{x^3}{r^4} dx = \frac{1}{2} \text{ (assuming } \mu = 1)$$

Between the conductors the flux interlinks with the whole current, and hence by a similar reasoning we get

$$L_2 = \frac{1}{I} \int_r^R 2I \frac{dx_1}{x_1} = 2 \log \frac{R}{r}$$

The current in the inner conductor interlinks with the entire flux which is inside of the outer conductor but which is caused by the difference in m.m.f. in the inner and outer conductor.

At a distance x_0 the m.m.f. is thus

$$I - \frac{x_0^2 - R^2}{R_0^2 - R^2} I = I \frac{R_0^2 - x_0^2}{R_0^2 - R^2}$$

The interlinkage of this flux with the current in the inner conductor is of course unity; therefore

$$L_3 = \frac{1}{I} \int \frac{2I}{x_0} \frac{R_0^2 - x_0^2}{R_0^2 - R^2} dx_0 = \frac{2R_0^2}{R_0^2 - R^2} \log \frac{R_0}{R} - 1$$

The inductance of the outer conductor should be added to give the total inductance of the cable.

The m.m.f. is $-I \frac{R_0^2 - x_0^2}{R_0^2 - R^2}$

The interlinkage factor is

$$\frac{x_0^2 - R^2}{R_0^2 - R^2}$$

$$\begin{aligned} \therefore L_4 &= -\frac{1}{I} \int \frac{2I}{x_0} \frac{(R_0^2 - x_0^2)}{(R_0^2 - R^2)} (x_0^2 - R^2) dx_0 \\ &= -\frac{1}{2} \frac{R_0^2 + R^2}{R_0^2 - R^2} + \frac{2R_0^2 R^2}{(R_0^2 - R^2)^2} \log \frac{R_0}{R} \end{aligned}$$

The total inductance $L = L_1 + L_2 + L_3 + L_4$ which is readily proven to be:

$$L = \frac{1}{2} + 2 \log \frac{R}{r} + \frac{2R_0^4}{(R_0^2 - R^2)^2} \log \frac{R_0}{R} - \frac{1}{2} \frac{3R_0^2 - R^2}{R_0^2 - R^2}$$

This inductance is expressed in the absolute system of units. By dividing by 10^9 the inductance is expressed in henrys.

The combined inductance $L = 0.0039$ henrys; thus $r = 8.8$, $L = 0.0039$, and $C = 7.95$ m.f.

$$r^2 - \frac{4L}{c} = 77.5 - 1960 \text{ is thus negative.}$$

Therefore this problem comes under the second case and

$$S_t = \sqrt{\frac{4L}{C} - r^2} = 43.4.$$

$$\frac{S}{2L} = 5550 \frac{r}{2L} = 1130 \tan \gamma = \frac{S_1}{r} = 4.93r = 78.5$$

$$= 1.37 \text{ radians}$$

$$\therefore i = 23e^{-1130t} \sin 5550t$$

and $e_c = 500[1 - 1.02e^{-1130t} \sin (5550t + 1.37)].$

The frequency of the oscillation is $\frac{5550}{2\pi} = 885$ cycles, and the time for one oscillation 0.00113 sec.

The maximum value of the current is determined by differentiation. It occurs when $t = 0.000246$ sec. When $5550t = 78.5^\circ$, the current is 17.1 amp. The next maximum value occurs when $t = 0.000246 + 0.00113 = 0.001376$ sec.

The maximum value of the voltage across the condenser is also determined by differentiation. It occurs when $t = 0.000565$ sec., when $e_c = 763$ volts. The next high value occurs obviously at $t = 0.001695$ sec.

These curves are shown in Fig. 48.

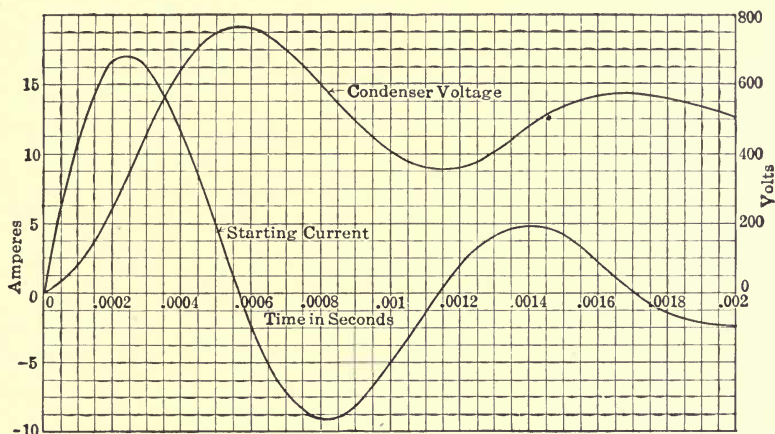

FIG. 48.

It is of interest to note that for a given *distance* of transmission the capacity, and therefore the charging current, is several times as great in the case of the concentric cable as in the case of the cable with parallel wires.

Similarly the inductance is several times as great in the case of an overhead line as in the case of the cable. As a second numerical application of these equations will be considered: 100 miles of overhead transmission line supplying energy to a cable network 50 miles in length.

It will be assumed that the cable system consists of a large number of short cables projecting in different directions from the terminal substation, as would be the case when a high-tension

line supplies energy to a city lighting network. The resistance of the cable system can therefore be neglected. It will be assumed that the high-potential line is three-phase and consists of No. 00 B. & S. wire, having a resistance per 100 miles of 40 ohms and an inductance of approximately 0.2 henry. Hence the capacity of the overhead line is very small compared with that of the cable and it will be neglected.

The problem is to determine the values of the current and voltage across the condenser when a steady e.m.f. of E volts is applied at the generating station.

$$E = 100$$

$$r = 40$$

$$L = 0.2$$

$$C = 0.0001 \text{ farad.}$$

$$\therefore r^2 = 1600$$

$$\frac{4L}{C} = 0.8 \times 10^4 = 8000.$$

$$\therefore r^2 = \frac{4L}{C} \text{ is negative.}$$

Therefore there is an oscillation when the switch is closed, and the constants are to be obtained from case (b).

$$S_1 = \sqrt{\frac{4L}{C} - r^2} = 80, \quad \frac{S_1}{r} = \frac{80}{40} = 2 \therefore \tan \gamma = 2$$

and

$$\gamma = 63.5 \quad \frac{r}{2L} = \frac{40}{-4} = -10, \quad \frac{S_1}{2L} = \frac{80}{0.4} = 160$$

$$\therefore i = 0.025E\epsilon^{-100t} \sin 160t$$

and

$$e_1 = E[1 - \epsilon^{-100t} 1.12 \sin (160t + 63.5^\circ)].$$

The time for a complete cycle is $\frac{2\pi}{160} = 0.0392$ sec., corresponding

to a natural frequency of $\frac{1}{T} = 25.5$ cycles per sec. It is interesting to see that the effect of the resistance is to lower the natural frequency, since if the resistance is neglected it would be

$$\frac{1}{2\pi\sqrt{LC}} = 35.5 \text{ cycles.}$$

Circuit Containing Resistance, Inductance and Capacity in Series. Harmonic E.m.f. Impressed.—Fig. 49. From previous discussions it is evident that the general equation is

$$E \sin \omega t = ir + L \frac{di}{dt} + \frac{1}{C} \int idt \quad (1)$$

or

$$E \sin \theta = ir + x \frac{di}{d\theta} + x_c \int id\theta \quad (2)$$

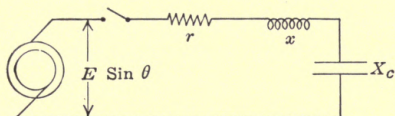

FIG. 49.

The latter form is preferable when dealing with alternating-current phenomena, but of course it must be remembered that x and x_c refer to the impressed frequency and not to the natural frequency of the system; that is,

$$x = 2\pi fL \text{ and } x_c = \frac{1}{2\pi fC}.$$

The solution of (2) can best be obtained by differentiating twice,

$$\begin{aligned} E \cos \theta &= r \frac{di}{d\theta} + x \frac{d^2i}{d\theta^2} + x_c i - E \sin \theta \\ E \sin \theta &= r \frac{d^2i}{d\theta^2} + x \frac{d^3i}{d\theta^3} + x_c \frac{di}{d\theta} \\ &= -ir - x \frac{di}{d\theta} - x_c \int id\theta \end{aligned} \quad (3)$$

Differentiating (3) and rearranging the equation:

$$x \frac{d^4i}{d\theta^4} + r \frac{d^3i}{d\theta^3} + (x_c + x) \frac{d^2i}{d\theta^2} + r \frac{di}{d\theta} + x_c i = 0 \quad (4)$$

The auxiliary equation is:

$$\begin{aligned} xm^4 + rm^3 + (x_c + x)m^2 + rm + x_c &= 0 \\ m^2(xm^2 + rm + x_c) + xm^2 + rm + x_c &= 0 \\ \therefore (m^2 + 1)(xm^2 + rm + x_c) &= 0 \end{aligned}$$

$$\therefore m = \pm j \text{ and } m = -\frac{r}{2x} \pm \frac{\sqrt{r^2 - 4xx_c}}{2x}$$

Let

$$\frac{r}{2x} = \alpha \text{ and } \frac{\sqrt{r^2 - 4xx_c}}{2x} = \beta \quad (5)$$

then

$$\begin{aligned} m_1 &= +j \\ m_2 &= -j \\ m_3 &= -\alpha + \beta \\ m_4 &= -\alpha - \beta \end{aligned}$$

$$\text{and } i = A_1 \sin(\theta + A_2) + \epsilon^{-\alpha\theta} (A_3 \epsilon^{-\beta\theta} + A_4 \epsilon^{-\beta\theta}) \quad (6)$$

The integration constants A_1 and A_2 could be found by methods outlined in the chapter on circuits of inductance and capacity. It is possible, however, for students familiar with elementary electrical engineering to determine them at once.

Apparently the first term represents the permanent and the second the transient condition. In permanent operation the current leads or lags behind the impressed e.m.f. by an angle ϕ which depends upon the numerical values of the two reactances. The final value of the current becomes, then,

$$i = \frac{E}{Z_0} \sin(\theta + \phi)$$

$$\text{if } \tan \phi = \frac{x_c - x}{r} \text{ and } Z_0 = \sqrt{r^2 + (x_c - x)^2} \quad (7)$$

$$\therefore i = \frac{E}{Z_0} \sin(\theta + \phi) + \epsilon^{-\alpha\theta} (A_3 \epsilon^{\beta\theta} + A_4 \epsilon^{-\beta\theta}) \quad (8)$$

The integration constants A_3 and A_4 depend upon the terminal conditions.

Before proceeding farther it is well to discuss the possible conditions, namely:

- (a) $r^2 - 4xx_c$ is positive.
- (b) $r^2 - 4xx_c$ is negative.
- (c) $r^2 - 4xx_c$ is zero.

Case (a).—

$$r^2 - 4xx_c \text{ is positive.}$$

Here β is real and the solution of i is given in equation (8).

Case (b).—

$$r^2 - 4xx_c \text{ is negative.}$$

$$\text{In this case } \sqrt{r^2 - 4xx_c} = j\sqrt{4xx_c - r^2} \quad (9)$$

$$\text{Let } \frac{\sqrt{4xx_c - r^2}}{2x} = \beta_1 \text{ and } \beta = j\beta_1 \quad (10)$$

$$\text{then } i = \frac{E}{Z_0} \sin(\theta + \phi) + A_7 \epsilon^{\alpha\theta} \sin(\beta_1\theta + \gamma) \quad (11)$$

where

$$A_7 = \sqrt{A_5^2 + A_6^2} = \sqrt{(A_3 + A_4)^2 + [(A_3 - A_4)]^2}$$

and

$$\gamma = \tan^{-1} \frac{A_5}{A_6} = \tan^{-1} \frac{A_3 + A_4}{(A_3 - A_4)}$$

also

$$i = \frac{E}{Z_0} \sin(\theta + \phi) + \epsilon^{-\alpha\theta} [A_5 \cos \beta_1\theta + A_6 \sin \beta_1\theta] \quad (12)$$

Case (c).— $r^2 = 4xx_c$.

If (12) is true, then $m_3 = m_4$, and we do not have a general solution; that is:

$$-\alpha + \beta = -\alpha - \beta \text{ since } \beta = 0 \quad (13)$$

A general solution is obtained by letting

$$m_4 = m_3 + h \quad (14)$$

where h is very small.

Here $m_3 = -\alpha$ and $m_4 = -\alpha + h$

then (see also equation 42, Chap. II),

$$i = \frac{E}{Z_0} \sin(\theta + \phi) + A_3\epsilon^{-\alpha\theta} + A_4\epsilon^{(-\alpha+h)\theta} \quad (15)$$

which may be written:

$$i = \frac{E}{Z_0} \sin(\theta + \phi) + \epsilon^{-\alpha\theta} [A_8 + A_9\theta] \quad (16)$$

where

$$A_8 = A_3 + A_4 \text{ and } A_9 = A_4h.$$

Each case will be considered independently.

Case (a).— $r^2 - 4xx_c$ (positive).

Since $r^2 - 4xx_c$ is positive, β is a real number and the solution of the differential equation (4) is:

$$i = \frac{E}{Z_0} \sin(\theta + \phi) + A_3\epsilon^{-(\alpha-\beta)\theta} + A_4\epsilon^{-(\alpha+\beta)\theta} \quad (17)$$

Let

$$(\alpha - \beta) = K \text{ and } (\alpha + \beta) = K_1 \quad (18)$$

By differentiating equation (17) and substituting in the equation

$$e_1 = E \sin \theta - ir - x \frac{di}{d\theta}, \quad (19)$$

the voltage across the condenser is:

$$e_1 = E \sin \theta - \frac{EZ}{Z_0} \sin(\theta + \phi + \Psi) + A_3\epsilon^{-K\theta} (Kx - r) + A_4\epsilon^{-K_1\theta} (K_1x - r) \quad (20)$$

where

$$\tan \Psi = \frac{x}{r} \quad (21)$$

$$Z = \sqrt{r^2 + x^2} \quad (22)$$

If the problem is to find the current and the condenser voltage at any instant after the circuit is closed, and if the circuit is closed when $\theta = \theta_1$, then $i = 0$ and $e_1 = 0$.

Substituting these conditions in equation (23), it may be written:

$$A_3\epsilon^{-K\theta_1} + A_4\epsilon^{-K_1\theta_1} = -\frac{E}{Z_0} \sin(\theta_1 + \phi) \quad (24)$$

Also equation (20) can be written:

$$A_3\epsilon^{-K\theta_1} (Kx - r) + A_4\epsilon^{-K_1\theta_1} (K_1x - r) = \frac{EZ}{Z_0} \sin(\theta_1 + \phi + \Psi) - E \sin \theta_1 \quad (25)$$

Solving equations (24) and (25) for A_3 and A_4 we have:

$$A_3 = \frac{E}{Z_0x(K - K_1)} \epsilon^{K\theta_1} [Z \sin(\theta_1 + \phi + \Psi) + (K_1x - r) \sin(\theta_1 + \phi) - Z_0 \sin \theta_1] \quad (26)$$

and,

$$A_4 = -\frac{E}{Z_0x(K - K_1)} \epsilon^{K_1\theta_1} [Z \sin(\theta_1 + \phi + \Psi) + (Kx - r) \sin(\theta_1 + \phi) - Z_0 \sin \theta_1] \quad (27)$$

Case (b).—As stated before the expression $\sqrt{r^2 - 4xx_c}$ is imaginary and from equation

$$\beta_1 = \sqrt{\frac{4xx_c - r^2}{2x}} \quad (28)$$

Equation (11) may be written:

$$i = \frac{E}{Z_0} \sin(\theta + \phi) + \epsilon^{-\alpha\theta} [A_5 \cos \beta_1\theta + A_6 \sin \beta_1\theta] \quad (29)$$

where $A_5 = A_3 + A_4$ and $A_6 = j(A_3 - A_4)$.

If the switch is closed at $\theta = \theta_1$, $e_1 = 0$ and $i = 0$. From these conditions

$$A_5 = \left[-\frac{E}{Z_0} \sin(\theta_1 + \phi) - A_6 \epsilon^{-\alpha\theta_1} \sin \beta_1\theta_1 \right] \frac{\epsilon^{\alpha\theta_1}}{\cos \beta_1\theta_1} \quad (30)$$

From these relations and the equation (19)

$$e_1 = E \sin \theta - ir - x \frac{di}{d\theta}$$

can be written

$$e_1 = E \sin \theta - \frac{EZ}{Z_0} \sin(\theta + \phi + \Psi) + \epsilon^{-\alpha\theta} [A_5[\beta_1x \sin \beta_1\theta + (\alpha x - r) \cos \beta_1\theta] + A_6[-\beta_1x \cos \beta_1\theta + (\alpha x - r) \sin \beta_1\theta]]$$

where

$$A_6 = \frac{E \cos \beta_1 \theta_1}{\beta_1 Z_0} \epsilon^{\alpha \theta} \left[\frac{Z_0}{x} \sin \theta_1 - \cos (\theta_1 + \phi) - \beta_1 \right. \\ \left. \sin (\theta_1 + \phi) \frac{\sin \beta_1 \theta_1}{\cos \beta_1 \theta} - \alpha \sin (\theta_1 + \phi) \right]$$

and

$$A_5 = - \left[\frac{E \sin (\theta_1 + \phi) \epsilon^{\alpha \theta_1} + A_6 Z_0 \sin \beta_1 \theta_1}{Z_0 \cos \beta_1 \theta} \right]$$

Case (c).—

($r^2 = 4xx_c$), or the “critical case.”

Equation (16) may be written:

$$i = \frac{E}{Z_0} \sin (\theta + \phi) + A_8 \epsilon^{-\alpha \theta} + A_9 \theta \epsilon^{-\alpha \theta} \quad (31)$$

If as before the switch is closed when $\theta = \theta_1$ then $i = 0$ and $e_1 = 0$. From these relations and the equation (19)

$$e_1 = E \sin \theta - ir - x \frac{di}{d\theta}$$

the condenser voltage is found to be:

$$e_1 = E \sin \theta - \frac{EZ}{Z_0} \sin (\theta + \phi + \Psi) + \epsilon^{-\alpha \theta} [A_8(\alpha x - r) + \\ A_9(\alpha x - x - r)] \quad (32)$$

where,

$$A_9 = \frac{E}{Z_0} \epsilon^{\alpha \theta_1} \left[\frac{Z_0}{x} \sin \theta_1 - \cos (\theta_1 + \phi) - \alpha \sin (\theta_1 + \phi) \right] \quad (33)$$

and

$$A_8 = - \frac{E}{Z_0} \epsilon^{\alpha \theta_1} \sin (\theta_1 + \phi) - A_9 \theta \quad (34)$$

CHAPTER V

A CIRCUIT CONTAINING DISTRIBUTED RESISTANCE AND INDUCTANCE

An aerial transmission line with negligible capacity and leakage conductance is an example of such circuit.

Fig. 50 represents an aerial transmission line with negligible capacity and leakage conductance and with a load having an impedance of $\sqrt{R_1^2 + L_1^2\omega^2}$.

Measuring x from the receiving end, consider an element of the line dx .

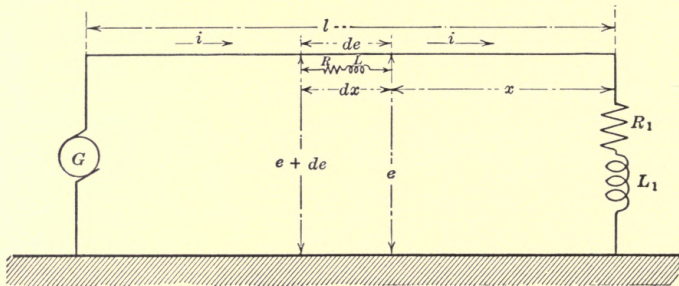

FIG. 50.

Let the resistance of the line be R ohms per unit length of the conductor and the inductance L henrys per unit length.

Then the resistance of the element is Rdx and its inductance Ldx , and the voltage across the element is de . Therefore,

$$de = Rdx i + Ldx \frac{di}{dt},$$

or

$$\frac{de}{dx} = Ri + L \frac{di}{dt} \quad (1)$$

As the same current flows in all parts of the line i is not a function of x , thus equation (1) is readily integrated, it is:

$$e = \left(Ri + L \frac{di}{dt} \right) x + K$$

where

$$x = 0, e = R_1 i + L_1 \frac{di}{dt}$$

$$\therefore K = R_1 i + L_1 \frac{di}{dt}$$

$$\therefore e = \left(R_1 i + L_1 \frac{di}{dt} \right) x + R_1 i + L_1 \frac{di}{dt} \quad (2)$$

where $x = l$, $e = E$ or $E \sin \omega t$, depending upon whether the generator voltage is constant (a) or alternating (b), therefore,

$$(a) \quad E = \left(R_1 i + L_1 \frac{di}{dt} \right) l + R_1 i + L_1 \frac{di}{dt} = (Rl + R_1) i + (Ll + L_1) \frac{di}{dt} \quad (3)$$

$$(b) \quad E \sin \omega t = (Rl + R_1) i + (Ll + L_1) \frac{di}{dt} \quad (4)$$

$Rl + R_1$ is the total resistance and $Ll + L_1$ the total inductance of the circuit. Hence, neglecting capacity and leakage conductance, a circuit of distributed resistance and inductance may be considered as if the resistance and inductance were concentrated as far as the determination of the current is concerned.

Case (a).—Unidirectional voltage impressed on the circuit.

For the current, solution of (3) gives

$$i = \frac{E}{Rl + R_1} \left(1 - e^{-\frac{Rl + R_1}{Ll + L_1} t} \right) \quad (\text{see equation (17), Chap. I}) \quad (5)$$

Substituting (5) in (2)

$$e = E \left[\frac{Rx + R_1}{Rl + R_1} + \left(\frac{Lx + L_1}{Ll + L_1} - \frac{Rx + R_1}{Rl + R_1} \right) e^{-\frac{Rl + R_1}{Ll + L_1} t} \right] \quad (6)$$

From (5) and (6) it is seen that at the moment of closing the circuit, that is, when $t = 0$, $i = 0$ and $e = \frac{Lx + L_1}{Ll + L_1} E$. In the

case of non-inductive load (when $L_1 = 0$), $e = \frac{x}{l} E$ and $e = 0$ for $x = 0$.

It is interesting to note, that, while resistances consume no voltages when $i = 0$, inductances *do* consume voltages when $i = 0$, provided $\frac{di}{dt} = 0$. When $t = \infty$, that is, when the current and the voltage reach their permanent conditions,

$$i = \frac{E}{Rl + R_1}, \quad e = \frac{Rx + R_1}{Rl + R_1} E, \quad \text{the expected results.}$$

Problem.—Assume reasonable values for the constants, and plot a series of curves for the voltages at various values of t and x .

Case (b).—Alternating voltage impressed on the circuit.

From equation (39) in Chap. I, the solution of (4) is found to be:

$$i = \frac{E}{Z} \left[\sin(\omega t - \beta) - \sin(\omega t_1 - \beta) \epsilon^{-\frac{Rl + R_1}{Ll + L_1}(t - t_1)} \right] \quad (7)$$

where t_1 is the time at which the circuit is closed.

$$Z = \sqrt{(Rl + R_1)^2 + (Ll + L_1)^2 \omega^2}$$

and

$$\beta = \tan^{-1} \frac{(Ll + L_1) \omega}{(Rl + R_1)}$$

Differentiating (7),

$$\frac{di}{dt} = \frac{E}{Z} \left[\omega \cos(\omega t - \beta) + \frac{Rl + R_1}{Ll + L_1} \sin(\omega t_1 - \beta) \epsilon^{-\frac{Rl + R_1}{Ll + L_1}(t - t_1)} \right] \quad (8)$$

Substituting (7) and (8) in (2), or,

$$e = EZ' \left[\frac{\sin(\omega t + \beta' - \beta)}{Z} + \frac{\sin(\beta' - \beta) \sin(\omega t_1 - \beta)}{Ll + L_1} \epsilon^{-\frac{Rl + R_1}{Ll + L_1}(t - t_1)} \right] \quad (9)$$

where

$$Z' = \sqrt{(Rx + R_1)^2 + (Lx + L_1)^2 \omega^2}, \text{ and } \beta' = \tan^{-1} \frac{(Lx + L_1) \omega}{(Rx + R_1)}$$

Referring to (7) and (9) it is seen that the current is the same as if the resistance and inductance were concentrated, but the voltage is different at different points, being modified in magnitude, and displaced in time phase.

It is noticed that no transient component in the voltage or current exists at any point of the line, if the circuit is closed at

$t_1 = \frac{\beta}{\omega}$, or in other words when $\sin(\omega t_1 - \beta) = 0$.

If $\sin(\omega t_1 - \beta)$ is not zero, the transient voltage appears at all values of x except $x = l$, for β' can not equal β , or $\frac{(Lx + L_1) \omega}{Rx + R_1}$

can not equal to $\frac{(Ll + L_1) \omega}{Rl + R_1}$ unless $x = l$.

When t becomes large, that is, many cycles after the circuit is closed, the exponential term approaches zero and the whole circuit becomes free of the transient, and (7) and (9) become:

$$i = \frac{E}{Z} \sin(\omega t - \beta) \quad (10)$$

$$e = \frac{EZ'}{Z} \sin(\omega t + \beta' - \beta) \quad (11)$$

where $x = l$, that is, at the generating end, $\frac{Z'}{Z} = 1$

$\beta' = \beta$, therefore,

$e = E \sin \omega t$, as assumed.

The voltages at other values of x can readily be computed from (11) and it is seen at once that the amplitude is proportional to $\frac{Z'}{Z}$ and the phase is $(\beta' - \beta)$ radians leading the impressed e.m.f.

The effective value of the voltage at any value of x is:

$$e_{eff} = E_{eff} \frac{Z'}{Z} \quad (12)$$

where e_{eff} = the effective value of the voltage at x , and E_{eff} that at generator, that is, at $x = l$.

When the line is open, that is, when $R_1 = \infty$, then (7) and (9) become: $i = 0$, and $e = E \sin \omega t$ for all values of x . No current flows, which is to be expected.

Grounding the receiving end of the line, $R_1 = 0$ and $L_1 = 0$.

$\therefore \frac{Z'}{Z} = \frac{x}{l}$ and $\beta' = \beta$, hence (7) and (9) become:

$$i = \frac{E}{lZ''} [\sin(\omega t - \beta'') - \sin(\omega t_1 - \beta'') \epsilon^{-\frac{R}{L}(t-t_1)}] \quad (13)$$

and

$$e = \frac{Ex}{L} \sin \omega t \quad (14)$$

where

$$Z'' = \sqrt{R^2 + L^2\omega^2}, \text{ and } \beta'' = \tan^{-1} \frac{L\omega}{R}$$

It is interesting to note that in this case the voltage has no transient component and is in time-phase throughout the line.

PROBLEMS

1. Assume reasonable constants of the circuit for equation (9) and plot e against t for (a) $x = 0$, (b) $x = \frac{l}{2}$.

2. When an accidental ground occurs on an aerial transmission line the voltage 10 miles away from the generator station is found to be 60 per cent. of the generator voltage. Determine the point of grounding.

CHAPTER VI

CIRCUIT CONTAINING DISTRIBUTED LEAKAGE CONDUCTANCE AND CAPACITY

A low-voltage cable may be considered as an approximate representation of such a circuit, since it contains distributed leakage conductance and capacity but usually low resistance and inductance. Since the resistance and inductance are considered negligible as a limiting case, it remains to consider a system of parallel conductance and capacity. The voltage may be considered the same at all points of the circuit, that is, independent of x .

Let i in Fig. 51 be the current at x , then $i + \frac{\partial i}{\partial x} dx$ is the current at $x + dx$. Let C be the capacity in farads per unit length of the conductor against the ground or neutral, and G the conductance

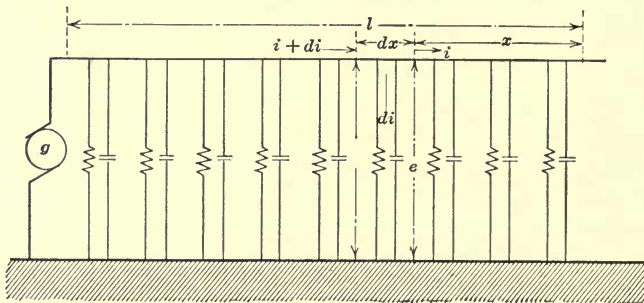

FIG. 51.

in ohms per unit length of the conductor to the neutral. Hence the current in the path of the capacity is $C dx \frac{de}{dt}$, and the current in the path of the conductance is $G dx e$. The difference in current between the two sides of the element dx is $\frac{\partial i}{\partial x} dx$. Therefore

$$\frac{\partial i}{\partial x} dx = C dx \frac{de}{dt} + G dx e,$$

or

$$\frac{\partial i}{\partial x} = C \frac{de}{dt} + Ge \tag{1}$$

This equation is similar to (1) in Chap. V with i for e , e for i , C for L , and G for R .

As e is independent of x , equation (1) integrated gives:

$$i = \left(C \frac{de}{dt} + Ge \right) x + K \quad (2)$$

It is of no interest to consider short circuit of the cable, since the resistance and inductance are neglected, for it would mean a dead short-circuit on the generator. Therefore consider the case of switching the generator on the open cable. Thus, where $x = 0$, $i = 0$. $\therefore K = 0$, and (2) becomes:

$$i = \left(C \frac{de}{dt} + Ge \right) x \quad (3)$$

Case (a).—Unidirectional voltage impressed on the cable.

In this case, it is assumed that $e = E$ from $t = 0$ to $t = \infty$, but just before $t = 0$, $e = 0$. Therefore it is assumed that $\frac{de}{dt} = \infty$ just before $t = 0$, and $\frac{de}{dt} = 0$, just after $t = 0$; that is, equivalent to assuming that the fictitious condensers were charged with an infinitely large current during an infinitely small period. In reality, the rise of the impressed e.m.f. takes time, though extremely short, and the resistance and inductance of the circuit limit the initial value of the current and lengthen the period of charging.

These assumptions thus do not allow a study of the transient condition. The equation indicates simply that $i = \infty$, for $t = 0$. For the permanent condition we have $\frac{de}{dt} = 0$, and (3) becomes:

$$i = GE x \quad (4)$$

which is expected.

Case (b).—Alternating voltage impressed on the cable.

Let the impressed e.m.f. be $e = E \sin \omega t$, and the time of applying to the cable be t_1 , thus $e = E \sin \omega(t - t_1)$. Hence,

$$\frac{de}{dt} = E\omega \cos \omega(t - t_1).$$

Substituting these in (3)

$$i = [C\omega \cos \omega(t - t_1) + G \sin \omega(t - t_1)]Ex,$$

or
$$i = Ex\sqrt{C^2\omega^2 + G^2} \sin(\omega t - \omega t_1 + \beta) \quad (5)$$

where

$$\beta = \tan^{-1} \frac{C\omega}{G}.$$

This equation represents the permanent values of the current, and shows that the current is proportional to x at all values of t , and leads the impressed e.m.f. by β radians at all values of x . The transient component does not appear in this equation, as explained in case (a).

The transients will be studied in the following chapters, where the capacity and inductance are considered.

CHAPTER VII

CIRCUIT CONTAINING DISTRIBUTED RESISTANCE AND CAPACITY

In the study of the problems involving distributed inductance and capacity, and the simpler problems involving the penetration of current or flux in conductors, etc., where alternating current of sine shape is assumed, a certain differential equation, given below is met.

Its solution is of importance to the engineer and deserves consideration.

The equation is

$$\frac{\partial^2 y}{\partial x^2} = k^2 \frac{\partial y}{\partial t} \quad (1)$$

A general solution which can readily be verified differentiation is:

$$y = A_0 + \sum A \epsilon^{ax+bt} \sin(\alpha x + \beta t + \gamma) \quad (2)$$

or

$$y = A_0 + A_1 \epsilon^{a_1 x + b_1 t} \sin(\alpha_1 x + \beta_1 t + \gamma_1) \\ + A_2 \epsilon^{a_2 x + b_2 t} \sin(\alpha_2 x + \beta_2 t + \gamma_2) + \dots$$

The evaluation of the different constants is accomplished partly from the known conditions at some points of the system, and partly by solving for the constants by differentiation and substitution.

In most problems, y or its derivative is known at some point, where for instance after permanent condition has been reached

$$y = Y \sin \omega t.$$

If the point happens to be where $x = x_1$, then equation (2) becomes

$$Y \sin \omega t = A_0 + \sum A \epsilon^{ax_1+bt} \sin(\alpha x_1 + \beta t + \gamma) \\ = A_0 + \sum A' \epsilon^{bt} \sin(\beta t + \gamma) \\ = A_0 + A'_1 \epsilon^{b_1 t} \sin(\beta_1 t + \gamma'_1) + A'_2 \epsilon^{b_2 t} \sin(\beta_2 t + \gamma'_2) + \dots$$

Writing the equivalent of sines in terms of ϵ

$$\begin{aligned} Y - \frac{\epsilon^{j\omega t} - \epsilon^{-j\omega t}}{2j} &= A_0 + A'_1 \epsilon^{b_1 t} \frac{j(\beta_1 t + \gamma'_1) - j(\beta_2 t \gamma'_2)}{2j} \\ &+ A'_2 \epsilon^{b_2 t} \frac{\epsilon^{j(\beta_2 t + \gamma'_2)} - \epsilon^{-j(\beta_2 t + \gamma'_2)}}{2j} + \dots \\ &= A_0 + A'_1 \frac{\epsilon^{b_1 t + j(\beta_1 t + \gamma'_1)} - \epsilon^{b_1 t - j(\beta_2 t + \gamma'_2)}}{2j} + \dots \end{aligned}$$

Thus, since the left-hand member contains the imaginary only, and the right-hand member a constant and the complex imaginary and the two sides must be equal for all values of t it is evident that A_0 and the b 's are separately equal to zero.

$$\therefore y = \Sigma A \epsilon^{ax} \sin (\alpha x + \beta t + \gamma) \quad (3)$$

$$\frac{\partial y}{\partial x} = \Sigma A \epsilon^{ax} [a \sin (\alpha x + \beta t + \gamma) + \alpha \cos (\alpha x + \beta t + \gamma)]$$

$$\frac{\partial^2 y}{\partial x^2} = \Sigma A \epsilon^{ax} (a^2 - \alpha^2) \sin (\alpha x + \beta t + \gamma) + 2a\alpha \cos (\alpha x + \beta t + \gamma)$$

$$\frac{\partial y}{\partial t} = \Sigma A \epsilon^{ax} \beta \cos (\alpha x + \beta t + \gamma)$$

Substituting these values in (1) and equating the coefficients for similar trigonometric terms,

$$a^2 - \alpha^2 = 0, \text{ and } 2a\alpha = k^2\beta \quad (4)$$

$\therefore (a + \alpha)(a - \alpha) = 0$, thus $a + \alpha = 0$, or $a - \alpha = 0$, or both.

For $a + \alpha = 0$, or $a = -\alpha$, the second equation of (4) gives, $-2\alpha^2 = k^2\beta$, which is evidently impossible. Thus there remains only $a - \alpha = 0$ or $a = \alpha$.

Then $2\alpha^2 = k^2\beta$, or, $a = \alpha = \pm k \sqrt{\frac{\beta}{2}}$ where a and α must have like signs.

The general solution then becomes:

$$y = A_1 \epsilon^{ax} \sin (ax + \beta t + \gamma_1) + A_2 \epsilon^{-ax} \sin (-ax + \beta t + \gamma_2) \quad (5)$$

and,

$$\begin{aligned} \frac{\partial y}{\partial x} &= A_1 \epsilon^{ax} a [\sin (ax + \beta t + \gamma_1) + \cos (ax + \beta t + \gamma_1)] \\ &- A_2 \epsilon^{-ax} a [\sin (-ax + \beta t + \gamma_2) + \cos (-ax + \beta t + \gamma_2)] \\ &= \sqrt{2} a \left[A_1 \epsilon^{ax} \sin (ax + \beta t + \gamma_1 + \frac{\pi}{4}) \right. \\ &\quad \left. - A_2 \epsilon^{-ax} \sin (-ax + \beta t + \gamma_2 + \frac{\pi}{4}) \right] \quad (6) \end{aligned}$$

Application of these equations will be found in the case of a circuit of distributed resistance and capacity but negligible inductance and leakage conductance, such circuit being approximately represented by the cable in Fig. 52.

Let R and C be the resistance and capacity respectively per unit length of the cable. Let the distance be counted from the receiving end of the line.

Let the voltage at B be e , and the voltage at A $e + \frac{\partial e}{\partial x} dx$.

\therefore the voltage consumed in the line element is:

$$e + \frac{\partial e}{\partial x} dx - e = \frac{\partial e}{\partial x} dx.$$

Let the current at B be i and the current at A be $i + \frac{\partial i}{\partial x} dx$.

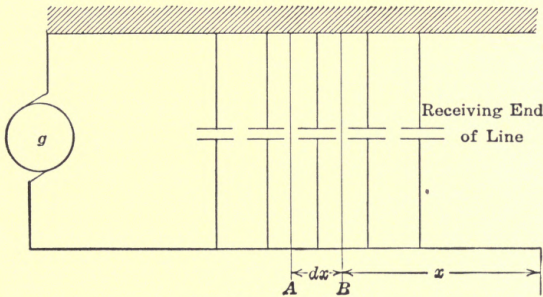

FIG. 52.

Thus the difference in current on each side of the line element is

$$i + \frac{\partial i}{\partial x} dx - i = \frac{\partial i}{\partial x} dx.$$

$$\therefore \frac{\partial e}{\partial x} dx = iRdx,$$

or,

$$\frac{\partial e}{\partial x} = iR \quad (7)$$

The difference in current on each side of the element is the charging current of the element.

$$\therefore \frac{\partial i}{\partial x} dx = Cdx \frac{\partial e}{\partial t} \quad (8)$$

or

$$\frac{\partial i}{\partial x} = C \frac{\partial e}{\partial t}$$

From equation (7) we get: $\frac{\partial i}{\partial x} = \frac{1}{R} \frac{\partial^2 e}{\partial x^2}$

$$\therefore \frac{1}{R} \frac{\partial^2 e}{\partial x^2} = C \frac{\partial e}{\partial t},$$

or, $\frac{\partial^2 e}{\partial x^2} = CR \frac{\partial e}{\partial t}$ (9)

Referring now to the general equation, it is seen that $k^2 = CR$, and $y = e$, and $a = \alpha = \pm \sqrt{\frac{RC\beta}{2}}$

$\therefore e = A_1 \epsilon^{ax} \sin(ax + \beta t + \gamma_1) + A_2 \epsilon^{-ax} \sin(-ax + \beta t + \gamma_2)$ (10)
and,

$$i = \frac{1}{R} \frac{\partial e}{\partial x} = \frac{\sqrt{2}a}{R} \left[A_1 \epsilon^{ax} \sin\left(ax + \beta t + \gamma_1 + \frac{\pi}{4}\right) - A_2 \epsilon^{-ax} \sin\left(-ax + \beta t + \gamma_2 + \frac{\pi}{4}\right) \right] \quad (11)$$

Case (a).—Alternating current supplied to a circuit of distributed resistance and capacity.

Example No. 1.—If the voltage at the generator end of the line ($x = e$) is $e = E \sin \omega t$, and if the cable is open at the receiving end, then $i = 0$ for $x = 0$ and all values of t , and $e = E \sin \omega t$ for $x = e$. From (10)

$$E \sin \omega t = A_1 \epsilon^{al} \sin(al + \beta t + \gamma_1) + A_2 \epsilon^{-al} \sin(-al + \beta t + \gamma_2)$$

$$= [A_1 \epsilon^{al} \cos(al + \gamma_1) + A_2 \epsilon^{-al} \cos(-al + \gamma_2)] \sin \beta t +$$

$$[A_1 \epsilon^{al} \sin(al + \gamma_1) + A_2 \epsilon^{-al} \sin(-al + \gamma_2)] \cos \beta t$$

$$\therefore A_1 \epsilon^{al} \cos(al + \gamma_1) + A_2 \epsilon^{-al} \cos(-al + \gamma_2) = E$$

and $\beta = \omega$,

and $A_1 \epsilon^{al} \sin(al + \gamma_1) + A_2 \epsilon^{-al} \sin(-al + \gamma_2) = 0$ (12)

For $x = 0$, $i = 0$ for all values of t from (11),

$$0 = A_1 \sin\left(\beta t + \gamma_1 + \frac{\pi}{4}\right) - A_2 \sin\left(\beta t + \gamma_2 + \frac{\pi}{4}\right)$$

Since this must hold for all values of t ,

$$A_1 = A_2 = A \text{ and } \gamma_1 = \gamma_2 = \gamma$$

Then from (12) we have:

$$A = \frac{E}{\epsilon^{al} \cos(al + \gamma) + \epsilon^{-al} \cos(-al + \gamma)}$$

and, $\epsilon^{al} \sin(al + \gamma) + \epsilon^{-al} \sin(-al + \gamma) = 0$

$$\text{or, } \begin{cases} \gamma = \tan^{-1} \left[-\frac{\epsilon^{al} - \epsilon^{-al}}{\epsilon^{al} + \epsilon^{-al}} \tan al \right], \text{ and} \\ A = \frac{E}{\sqrt{\epsilon^{2al} + \epsilon^{-2al} + 2(\cos^2 al - \sin^2 al)}} \end{cases} \quad (13)$$

$$e = A[\epsilon^{ax} \sin(ax + \omega t + \gamma) + \epsilon^{-ax} \sin(-ax + \omega t + \gamma)] \quad (14)$$

and,

$$i = \sqrt{\frac{C\omega}{R}} A \left[\epsilon^{ax} \sin \left(ax + \omega t + \gamma + \frac{\pi}{4} \right) - \epsilon^{-ax} \sin \left(-ax + \omega t + \gamma + \frac{\pi}{4} \right) \right] \quad (15)$$

Where A and γ are given in (13) and

$$a = + \sqrt{\frac{RC\omega}{2}}$$

If the voltage at the receiving end of the line were known rather than the voltage at the generator then:

$$e = E_0 \sin \omega t \text{ for } x = 0,$$

E_0 being the maximum value of the voltage at the receiving end of the line.

Thus,

$$\begin{aligned} E_0 \sin \omega t &= A_1 \sin(\beta t + \gamma_1) + A_2 \sin(\beta t + \gamma_2) \\ &= \sin \beta t (A_1 \cos \gamma_1 + A_2 \cos \gamma_2) + \cos \beta t (A_1 \sin \gamma_1 + A_2 \sin \gamma_2) \\ \therefore A_1 \cos \gamma_1 + A_2 \cos \gamma_2 &= E_0, \beta = \omega \text{ and, } A_1 \sin \gamma_1 \\ &\quad + A_2 \sin \gamma_2 = 0 \end{aligned} \quad (16)$$

For $x = 0$, $i = 0$ for all values of t (assuming again an open line).

$$\therefore A_1 \sin \left(\beta t + \gamma_1 + \frac{\pi}{4} \right) = A_2 \sin \left(\beta t + \gamma_2 + \frac{\pi}{4} \right)$$

$$\text{or, } \begin{aligned} A_1 \sin \beta t \cos \left(\gamma_1 + \frac{\pi}{4} \right) + A_1 \cos \beta t \sin \left(\gamma_1 + \frac{\pi}{4} \right) &= \\ A_2 \sin \beta t \cos \left(\gamma_2 + \frac{\pi}{4} \right) + A_2 \cos \beta t \sin \left(\gamma_2 + \frac{\pi}{4} \right) & \end{aligned}$$

In order that this shall hold for all values of t , the coefficients of the similar trigonometric terms of t must be the same.

$$\left. \begin{aligned} \therefore A_1 \cos \left(\gamma_1 + \frac{\pi}{4} \right) &= A_2 \cos \left(\gamma_2 + \frac{\pi}{4} \right) \text{ and,} \\ A_1 \sin \left(\gamma_1 + \frac{\pi}{4} \right) &= A_2 \sin \left(\gamma_2 + \frac{\pi}{4} \right) \\ \therefore \tan \left(\gamma_1 + \frac{\pi}{4} \right) &= \tan \left(\gamma_2 + \frac{\pi}{4} \right), \end{aligned} \right\} \quad (17)$$

$$\text{or, } \gamma_1 = \gamma_2 = \gamma.$$

Then from (16)

$$(A_1 + A_2) \cos \gamma = E_0 \text{ and } (A_1 + A_2) \sin \gamma = 0 \\ \therefore \gamma = 0 \text{ and } A_1 + A_2 = E_0.$$

From (17)

$$A_1 = A_2 = A \quad \therefore A = \frac{E_0}{2}.$$

Therefore

$$e = \frac{E_0}{2} [\epsilon^{ax} \sin(ax + \omega t) + \epsilon^{-ax} \sin(-ax + \omega t)] \quad (18)$$

and,

$$i = \frac{E_0}{2} \sqrt{\frac{C\omega}{R}} \left[\epsilon^{ax} \sin\left(ax + \omega t + \frac{\pi}{4}\right) - \epsilon^{-ax} \sin\left(-ax + \omega t + \frac{\pi}{4}\right) \right] \quad (19)$$

where $a = +\sqrt{\frac{RC\omega}{2}}$ and E_0 is the maximum value of the e.m.f. at the receiving end.

In the examples, both 1 and 2, the current leads the voltage by 45° at all points of the line.

Let e_0 be the voltage at the receiving end and e_1 that at the generating end.

From (14)

$$e_0 = 2A \sin(\omega t + \gamma) = \frac{2E \sin(\omega t + \gamma)}{\sqrt{\epsilon^{2al} + \epsilon^{-2al} + 2(\cos^2 al - \sin^2 al)}}$$

and

$$e_1 = E \sin(\omega t)$$

From (18)

$$e_0 = E_0 \sin(\omega t),$$

and

$$e_1 = \frac{E_0}{2} [\epsilon^{al} \sin(al + \omega t) + \epsilon^{-al} \sin(-al + \omega t)] \\ = \frac{E_0}{2} [(\epsilon^{al} + \epsilon^{-al}) \cos al \sin \omega t + (\epsilon^{al} - \epsilon^{-al}) \sin al \cos \omega t] \\ = 2E_0 \sqrt{\epsilon^{2al} + \epsilon^{-2al} + 2(\cos^2 al - \sin^2 al)} \sin(\omega t - \gamma).$$

Hence both equations show that, (a) the voltage at the receiving end leads the generator voltage by an angle γ , and (b) the maximum voltage at the receiving end is:

$$\frac{2}{\sqrt{\epsilon^{2al} + \epsilon^{-2al} + 2(\cos^2 al - \sin^2 al)}}$$

times the maximum generator voltage. In fact examples (1) and (2) refer to one phenomenon, but one terminal condition already known and one terminal condition to be determined are interchanged in the statements of the examples.

Example No. 3.—The same phenomenon may be studied in still a different way, namely, measuring x from the generator end, that is, $x = l$ refers to the receiving end of the line.

When the generator is taken as the point from which the distance is measured, then, as the voltage and current decrease as x increases, we have:

$$-\frac{\partial e}{\partial x} dx = iR dx,$$

and

$$-\frac{\partial i}{\partial x} dx = C dx \frac{\partial e}{\partial t}$$

which by a similar transformation, also resolves in the differential equation:

$$\frac{\partial^2 e}{\partial x^2} = CR \frac{\partial e}{\partial t}$$

$$\therefore e = A_1 \epsilon^{ax} \sin(ax + \beta t + \gamma_1) + A_2 \epsilon^{-ax} \sin(-ax + \beta t + \gamma_2)$$

and,

$$i = -\sqrt{\frac{C\omega}{R}} \left[A_1 \epsilon^{ax} \sin\left(ax + \beta t + \gamma_1 + \frac{\pi}{4}\right) - A_2 \epsilon^{-ax} \sin\left(-ax + \beta t + 2\frac{\pi}{4}\right) \right]$$

For $x = l$. $i = 0$ for all values of t .

$$\therefore A_1 \epsilon^{al} \sin\left(al + \beta t + \gamma_1 + \frac{\pi}{4}\right) = A_2 \epsilon^{-al} \sin\left(-al + \beta t + \gamma_2 + \frac{\pi}{4}\right)$$

or,

$$= A_1 \epsilon^{al} \left[\sin \beta t \cos\left(al + \gamma_1 + \frac{\pi}{4}\right) + \cos \beta t \sin\left(al + \gamma_1 + \frac{\pi}{4}\right) \right]$$

$$= A_2 \epsilon^{-al} \left[\sin \beta t \cos\left(-al + \gamma_2 + \frac{\pi}{4}\right) + \cos \beta t \sin\left(-al + \gamma_2 + \frac{\pi}{4}\right) \right]$$

As this must hold for all values of t ,

$$\therefore A_1 \epsilon^{al} \cos\left(al + \gamma_1 + \frac{\pi}{4}\right) = A_2 \epsilon^{-al} \cos\left(-al + \gamma_2 + \frac{\pi}{4}\right)$$

and,

$$A_1 \epsilon^{al} \sin\left(al + \gamma_1 + \frac{\pi}{4}\right) = A_2 \epsilon^{-al} \sin\left(-al + \gamma_2 + \frac{\pi}{4}\right)$$

$$\therefore \tan\left(al + \gamma_1 + \frac{\pi}{4}\right) = \tan\left(-al + \gamma_2 + \frac{\pi}{4}\right)$$

$$\therefore \gamma_2 = \gamma_1 + 2al,$$

and it follows that,

$$A_2 = A_1 \epsilon^{2al} \tag{20}$$

For $x = 0$, $e = E \sin \omega t$;

$$\begin{aligned} \therefore E \sin \omega t &= A_1 \sin (\beta t + \gamma_1) + A_2 \sin (\beta t + \gamma_2) \\ &= (A_1 \cos \gamma_1 + A_2 \cos \gamma_2) \sin \beta t + (A_1 \sin \gamma_1 + A_2 \sin \gamma_2) \cos \beta t. \end{aligned}$$

In order to make this hold for all values of t ,

$$\beta = \omega$$

$$A_1 \cos \gamma_1 + A_2 \cos \gamma_2 = E,$$

and

$$A_1 \sin \gamma_1 + A_2 \sin \gamma_2 = 0.$$

From (20)

$$A_1 \sin \gamma_1 + A_1 \epsilon^{2al} \sin (\gamma_1 + 2al) = 0$$

$$\therefore \sin \gamma_1 = -\epsilon^{2al} (\sin \gamma_1 \cos 2al + \cos \gamma_1 \sin 2al),$$

$$\therefore \gamma_1 = \tan^{-1} \frac{-\epsilon^{2al} \sin 2al}{1 + \epsilon^{2al} \cos 2al} \quad (21)$$

Let $\gamma = \gamma_1 + al$, then $\gamma_1 = \gamma - al$, and $\gamma_2 = \gamma + al$. And let $A = A_1 \epsilon^{al} = A_2 \epsilon^{-al}$. Then,

$$\epsilon^{-al} \cos (\gamma - al) + \epsilon^{al} \cos (\gamma + al) = \frac{E}{A} \quad (22)$$

From (21) and $\gamma_1 = \gamma - al$, we have:

$$\tan \gamma_1 = \tan (\gamma - al) = \frac{\sin (\gamma - al)}{\cos (\gamma - al)} = \frac{-\epsilon^{2al} \sin 2al}{1 + \epsilon^{2al} \cos 2al},$$

$$\therefore \gamma = \tan^{-1} \left[\frac{-\epsilon^{al} - \epsilon^{-al}}{\epsilon^{al} + \epsilon^{-al}} \tan al \right],$$

which is the same as that in example (1)

Substituting the value of γ in (22)

$$A = \frac{E}{\sqrt{\epsilon^{2al} + \epsilon^{-2al} + 2(\cos^2 al - \sin^2 al)}}$$

also the same as that in example (1).

Hence,

$$e = A \left[\epsilon^{-a(l-x)} \sin (-al - x + \omega t + \gamma) + \epsilon^{a(l-x)} \sin (al - x + \omega t + \gamma) \right]$$

$$\begin{aligned} i = -A \sqrt{\frac{C\omega}{R}} & \left[\epsilon^{-a(l-x)} \sin \left(-al - x + \omega t + \gamma + \frac{\pi}{4} \right) \right. \\ & \left. - \epsilon^{a(l-x)} \sin \left(al - x + \omega t + \gamma + \frac{\pi}{4} \right) \right] \end{aligned}$$

which are identical with the equations obtained in example (1), only with $(l - x)$ in the place of x .

It is noticed that at any particular point of the line the current and e.m.f. waves are sine waves.

The wave length λ is found when, $x\sqrt{\frac{CR\omega}{2}} = 2\pi$

$$\begin{aligned}\therefore x &= \lambda \frac{2\pi}{\sqrt{\frac{CR\omega}{2}}} = 2\pi\sqrt{\frac{2}{CR\omega}} \\ &= 2\pi\sqrt{\frac{2}{CR2\pi f}} = 2\sqrt{\frac{\pi}{fCR}}.\end{aligned}$$

The time required for the wave to go one complete wave length is $T = \frac{l}{f}$.

Thus the velocity of propagation is:

$$\text{vel.} = \frac{\text{distance}}{\text{time}} = 2\sqrt{\frac{\pi}{fCR}} \div \frac{l}{f} = 2\sqrt{\frac{f\pi}{CR}} = \sqrt{\frac{2\omega}{CR}}.$$

Thus the velocity of propagation is proportional to the square root of the frequency.

Higher harmonics travel faster than the fundamental. The third harmonic travels 73 per cent. faster, etc.

But while the higher harmonics travel faster than the fundamental their attenuation is greater as will be seen.

When the wave has traveled one complete wave length, that is, when $x = \lambda = 2\pi\sqrt{\frac{2}{CR\omega}}$

The exponential term becomes:

$$\epsilon^{-2\pi\sqrt{\frac{2}{CR\omega}}\sqrt{\frac{CR\omega}{2}}} = \epsilon^{-2\pi} = \frac{1}{\epsilon^{2\pi}} = 0.0019.$$

That is, the wave is only 0.2 per cent. of its original value. It has reached $\frac{l}{\epsilon} = \frac{1}{2.72} = 0.368$ of its original value when

$$x\sqrt{\frac{CR\omega}{2}} = 1, \text{ or } x = \sqrt{\frac{2}{CR\omega}} = \sqrt{\frac{2}{CR2\pi f}} = \sqrt{\frac{1}{CR\pi f}}.$$

Thus the third harmonic has decreased to 37 per cent. of its original value in a distance which is only 58 per cent. of that required by the fundamental to be reduced to 37 per cent. of its original value.

To find the time for the wave to decay to $\frac{1}{e}$ of its original value, we have:

$$\begin{aligned} \text{time} &= \frac{\text{distance}}{\text{velocity}} = \sqrt{\frac{1}{CR\pi f}} \div 2 \sqrt{\frac{f\pi}{CR}} = \\ &= \frac{1}{2} \sqrt{\frac{CR}{f\pi CR\pi f}} = \frac{1}{2\pi f} = \frac{1}{\omega}. \end{aligned}$$

Thus the time required for a given decay varies inversely as the frequency. The third harmonic requires only one-third of the time of that of the fundamental.

Instance.—A concentric cable 100 miles long. Assume a capacity of 1 m-f. per mile to the neutral.

Using the mile as the unit of distance,

$$C = 10^6.$$

Assume the cable to have a resistance (of one conductor) of 1 ohm per mile.

Then $R = 1$

At 60 cycles, $f = 60$ and $\omega = 377$.

\therefore Velocity of propagation = $\sqrt{\frac{2 \times 377}{10^6 \times 1}} = 27,500$ miles per sec. The velocity of the triple frequency wave would be,

$$\sqrt{3} \times 27,500 = 47,500 \text{ miles per sec.}$$

The main wave is reduced to 37 per cent. of its original value after $\frac{1}{377} = 0.00265$ sec.; and the triple frequency wave is reduced to the same fraction in one-third of the time or 0.0009 sec. In the first case the wave has traveled 73 miles; in the case of the triple harmonic 42 miles.

Problem.—Develop the equation of the voltage and the current in a closed cable under alternating impressed e.m.f.

Case (b).—Direct current supplied to the cable.

Example No. 1.—Consider the line open at the receiving end ($x = 0$).

Assume,

$$e = K + \Sigma A^{ax+bt} \sin(\alpha x + \beta t + \gamma)$$

where $x = 1$, $e = E$ for all values of t ,

This is evidently only possible if

$$\Sigma A e^{a+bt} \sin(\alpha + \beta t + \gamma) = 0 \text{ and } K = E.$$

As this must hold for all values of t , $\beta = 0$, and $al + \gamma = n\pi$.¹ It is found convenient to let $\gamma = -\frac{\pi}{2}$, that is, to make

$$\Sigma A \epsilon^{al+bt} \cos al = 0, \text{ and } al = n\pi + \frac{\pi}{2} = \frac{(2n+1)\pi}{2}$$

where

$$al = \frac{\pi}{2}, \frac{3\pi}{2}, \frac{5\pi}{2}, \frac{7\pi}{2}, \text{ etc.},$$

Thus,

$$e = E + \Sigma A \epsilon^{ax+bt} \cos \alpha x$$

$$\frac{\partial^2 e}{\partial x^2} = \Sigma A(a^2 - \alpha^2) \epsilon^{ax+bt} \cos \alpha x - \Sigma 2A\alpha a \epsilon^{ax+bt} \sin \alpha x$$

$$\frac{\partial e}{\partial t} = \Sigma A b \epsilon^{ax+bt}$$

Substituting these values in the general equation

$$\frac{\partial^2 e}{\partial x^2} = RC \frac{\partial e}{\partial t}$$

and equating the coefficient of similar trigonometric terms we get:

$$b = \frac{a^2 - \alpha^2}{CR}$$

and $\alpha x = 0$ or $a = 0$, since α can not equal zero.

$$\text{Thus, } e = E + \sum_{n=0}^{\infty} A_n \epsilon^{\frac{-\pi^2(1+2n)^2}{4RCl^2}t} \cos \frac{\pi(1+2n)x}{2l} \quad (23)$$

$$\text{and } i = \frac{1}{R} \frac{\partial e}{\partial x} = \frac{1}{R} \sum_{n=0}^{\infty} A_n \epsilon^{\frac{-\pi^2(1+2n)^2}{4RCl^2}t} \sin \frac{\pi(1+2n)x}{2l} \quad (24)$$

When $t = 0$, $x < 1$, $e = 0$

$$\therefore \sum_{n=0}^{\infty} A_n \cos \frac{\pi(1+2k)x}{2l} = -E$$

¹ In this equation appear several constants, some of which are determined by the terminal conditions, others by mathematical transformations. It is, of course, possible to do a certain amount of choosing as long as the choice satisfies the differential equation as well as the known conditions which exist in the problem. So, for instance, we may assign an arbitrary value of γ and carry the calculations through when we may find that the final expression is simple or too complicated to be of practical value.

It is reasonable that in the first trial γ may be assumed as zero. When the problem is worked out on this basis it is seen that the answer is not susceptible to a simple equation. The trial will suggest another value, most likely $\gamma = -\frac{\pi}{2}$. This is therefore used.

In order to determine the values of A_n , multiply both sides of (24) by $\cos \frac{\pi(1+2k)x}{2l} dx$ and integrate between 0 and l , thus

$$\int_0^l \cos \frac{\pi(1+2k)x}{2l} \sum_{n=0}^{\infty} A_n \cos \frac{\pi(1+2n)x}{2l} dx = -E \int_0^l \cos \frac{\pi(1+2k)x}{2l} dx.$$

Each term on the left-hand side equals zero except that one which has $n = k$, and hence this particular value is used, and we have

$$A_n \int_0^l \cos^2 \frac{\pi(1+2n)x}{2l} dx = -E \int_0^l \cos \frac{\pi(1+2n)x}{2l} dx$$

Integrated,

$$\frac{\pi(1+2n)}{4} A_n = -E(-1)^n, \therefore A_n = \frac{-(-1)^n 4E}{(1+2n)\pi}$$

$$\therefore e = E - \frac{4E}{\pi} \sum_{n=1}^{\infty} \frac{(-1)^n}{(1+2n)} \epsilon^{-\frac{\pi^2(1+2n)^2}{4RCl^2} t} \cos \frac{\pi(1+2n)x}{2l} \quad (25)$$

$$i = \frac{2E}{Rl} \sum_{n=1}^{\infty} (-1)^n \epsilon^{-\frac{\pi^2(1+2n)^2}{4RCl^2} t} \sin \frac{\pi(1+2n)x}{2l} \quad (26)$$

The voltage at the receiving end is:

$$e = E - \frac{4E}{\pi} \sum_{n=1}^{\infty} \frac{(-1)^n}{(1+2n)} \epsilon^{-\frac{\pi^2(1+2n)^2}{4RCl^2} t}.$$

For $x = 0, t = 0$

$$e = E = \frac{4E}{\pi} \sum_{n=1}^{\infty} \frac{(-1)^n}{1+2n},$$

which is zero, in accordance with the assumption made in developing the equation.

Therefore, incidentally, we get

$$1 = \frac{4}{\pi} \left(1 - \frac{1}{3} + \frac{1}{5} - \frac{1}{7} + \frac{1}{9} \mp \dots \right)$$

which is a known interesting series from which the value of π can be computed.

The current at the generating end is

$$i = \frac{2E}{Rl} \sum_{n=1}^{\infty} \epsilon^{-\frac{\pi^2(1+2n)^2}{4RCl^2} t} \quad (27)$$

when $t = 0$ and $x = l$,

$$i = \frac{2E}{Rl} (1 + 1 + 1 + \dots) = ,$$

which is a limiting value never reached, since with the slightest increase in t the series converges very rapidly.

For the sake of briefness, write m for $\frac{\pi^2}{rRCl^2}$ then, for $x = l$,

$$i = \frac{2E}{Rl}(\epsilon^{-mt} + \epsilon^{-9mt} + \epsilon^{-25mt} + \epsilon^{-49mt} + \dots) \quad (28)$$

From (28) it is readily seen, that, when t has any appreciable value, the current dies out approximately according to the exponential, ϵ^{-mt} . When the line is very long, the initial large current will remain during a considerable length of time. When l is very small, the limiting case is that of concentrated capacity. As $l = 0$ (28) approaches:

$$i = \frac{2E}{Rl}\epsilon^{-\frac{\pi^2}{4RCl^2}t}$$

Rl is the resistance and Cl the capacity of the entire line.

In the case of concentrated resistance and capacity it has been shown that

$$i = \frac{E}{R}\epsilon^{-\frac{l}{CR}t}$$

Comparing the equations it is seen that the transient current can be fairly well approximated by assuming that the line capacity is concentrated in the middle of the line.

Example No. 2.—In case the line is grounded at the receiving end, the permanent voltage is $\frac{Ex}{l}$.

Thus,

$$e = \frac{Ex}{l} + \sum A_n \epsilon^{-\frac{\alpha^2}{CR}t} \sin(\alpha x + \gamma)$$

γ may in this case be conveniently taken as zero, thus,

$$e = \frac{Ex}{l} + \sum A_n \epsilon^{-\frac{\alpha^2}{CR}t} \sin \alpha x$$

for $x = l$, $e = E$ for all values of t .

Thus $\sin \alpha l = 0$, and $\alpha l = n\pi$

$$\therefore e = \frac{Ex}{l} + \sum_{n=0}^{n=\infty} A_n \epsilon^{-\frac{n^2\pi^2}{CRl^2}t} \sin \frac{n\pi x}{l}$$

For $t = 0$, $e = 0$ for all values of $x < l$.

$$\therefore \sum A_n \sin \frac{n\pi x}{l} = -\frac{Ex}{l}$$

A_n is determined as before by multiplication and integration and we get finally:

$$e = \frac{Ex}{l} + \frac{2E}{\pi} \sum_{n=1}^{n=\infty} \frac{(-1)^n}{n} \epsilon^{-\frac{n^2\pi^2}{RCl^2}t} \sin \frac{n\pi x}{l} \quad (29)$$

$$i = \frac{E}{Rl} + \frac{2E}{Rl} \sum_{n=1}^{n=\infty} (-1)^n \epsilon^{-\frac{n^2\pi^2}{RCl^2}t} \cos \frac{n\pi x}{l} \quad (30)$$

The current at the receiving end is:

$$i = \frac{E}{Rl} \left[1 + 2 \sum_{n=1}^{n=\infty} (-1)^n \epsilon^{-\frac{n^2\pi^2}{RCl^2}t} \right] \quad (31)$$

CHAPTER VIII

DISTRIBUTED INDUCTANCE AND CAPACITY

Permanent Condition.—Let L and C (Fig. 53) be respectively the inductance and capacity per unit length of the circuit.

The voltage consumed in the line element dx is:

$$\frac{\partial e}{\partial x} dx = L \frac{\partial i}{\partial t} dx \quad (1)$$

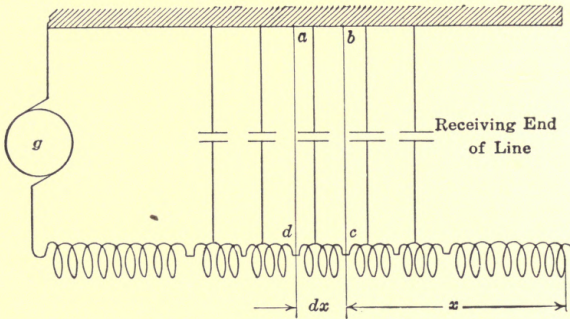

FIG. 53.

The difference in current between two sides of the element is:

$$\frac{\partial i}{\partial x} dx = C \frac{\partial e}{\partial t} dx \quad (2)$$

Differentiating (1) with respect to x

$$\frac{\partial^2 e}{\partial x^2} = L \frac{\partial i}{\partial t \partial x}$$

Differentiating (2) with respect to t ,

$$\begin{aligned} \frac{\partial^2 i}{\partial x \partial t} &= C \frac{\partial^2 e}{\partial t^2} \\ \therefore \frac{\partial^2 e}{\partial x^2} &= LC \frac{\partial^2 e}{\partial t^2} \end{aligned} \quad (3)$$

Similarly,

$$\frac{\partial^2 i}{\partial x^2} = LC \frac{\partial^2 i}{\partial t^2} \quad (4)$$

In this problem there is, therefore, encountered an equation of the following type:

$$\frac{\partial^2 y}{\partial t^2} = k^2 \frac{\partial^2 y}{\partial x^2} \quad (5)$$

An often successful procedure for finding particular solutions of simple partial equations of this or similar simple types, is to assume the solution to be:

$$y = UV \quad (6)$$

Where U is a function of t only and V is a function of x only. Differentiating, we get:

$$\left. \begin{aligned} \frac{\partial^2 y}{\partial x^2} &= U \frac{\partial^2 V}{\partial x^2} \\ \frac{\partial^2 y}{\partial t^2} &= V \frac{\partial^2 U}{\partial t^2} \end{aligned} \right\} \quad (7)$$

Substituting (7) in (5)

$$V \frac{\partial^2 U}{\partial t^2} = k^2 U \frac{\partial^2 V}{\partial x^2} \text{ or } \frac{1}{U k^2} \frac{\partial^2 U}{\partial t^2} = \frac{1}{V} \frac{\partial^2 V}{\partial x^2} \quad (8)$$

Since the left-hand member is a function of t only and the right-hand member a function of x only, it follows that each side of the equation must be equal to the same constant. Let that constant be $-\alpha^2$.

$$\text{and } \left. \begin{aligned} \therefore \frac{\partial^2 U}{\partial t^2} &= -\alpha^2 k^2 U \\ \frac{\partial^2 V}{\partial x^2} &= -\alpha^2 V \end{aligned} \right\} \quad (9)$$

The following trigonometric terms evidently satisfy (9).

$$\begin{aligned} U &= \sin \alpha kt \text{ or } U = \cos \alpha kt \\ V &= \sin \alpha x \text{ or } V = \cos \alpha x \end{aligned} \quad (10)$$

Thus the solution is:

$$y = K + \Sigma [A_1 \sin \alpha x \sin \alpha kt + A_2 \sin \alpha x \cos \alpha kt + A_3 \cos \alpha x \sin \alpha kt + A_4 \cos \alpha x \cos \alpha kt] \quad (11)$$

Where A_1, A_2, A_3, A_4 and K are to be determined, and $k = \sqrt{\frac{1}{CL}}$ and the Σ sign refers to summation with all possible values of α .

Consider now the specific case of an open alternating-current line of negligible resistance and leakage. Determine the values of the current and e.m.f. at any time at any point of the line after the permanent condition has been reached.

If the distance is counted from the generator end the generator voltage is $e = E \sin \omega t$

$$\text{then} \quad - \frac{\partial i}{\partial x} dx = + C \frac{\partial e}{\partial t} dx \quad (12)$$

$$\text{and,} \quad - \frac{\partial e}{\partial x} dx = L \frac{\partial i}{\partial t} dx \quad (13)$$

The final differential equation becomes, the same as equation (3).

The conditions for open line are:

$$\text{for } x = 0, e = E \sin \omega t$$

for $x = l, i = 0$ for all values of t .

Since we are dealing with permanent condition the current and e.m.f. vary with fundamental frequency and the solution is therefore:

$$\begin{aligned} e &= A_1 \sin \alpha x \sin kat + A_2 \sin \alpha x \cos kat + \\ &\quad A_3 \cos \alpha x \sin kat + A_4 \cos \alpha x \cos kat \\ i &= A_5 \sin \alpha x \sin kat + A_6 \sin \alpha x \cos kat + \\ &\quad A_7 \cos \alpha x \sin kat + A_8 \cos \alpha x \cos kat \end{aligned} \quad (15)$$

These are related by the equation:

$$\frac{\partial e}{\partial x} = - L \frac{\partial i}{\partial t}$$

$$\begin{aligned} \frac{\partial e}{\partial x} &= \alpha[A_1 \cos \alpha x \sin kat + A_2 \cos \alpha x \cos kat - \\ &\quad A_3 \sin \alpha x \sin kat - A_4 \sin \alpha x \cos kat]. \end{aligned}$$

$$\begin{aligned} L \frac{\partial i}{\partial t} &= Lk\alpha[A_5 \sin \alpha x \cos kat - A_6 \sin \alpha x \sin kat + \\ &\quad A_7 \cos \alpha x \cos kat - A_8 \cos \alpha x \sin kat]. \end{aligned}$$

Equating the coefficients for similar trigonometric terms, of t ,

$$\left. \begin{aligned} A_1 \cos \alpha x - A_3 \sin \alpha x &= -Lk[-A_6 \sin \alpha x - A_8 \cos \alpha x] \\ \text{and,} \\ A_2 \cos \alpha x - A_4 \sin \alpha x &= -Lk[A_5 \sin \alpha x + A_7 \cos \alpha x] \end{aligned} \right\} (A)$$

Since these must hold for all values of x , we can substitute $\alpha x = 0$ and $\alpha x = \frac{\pi}{2}$,

$$\therefore A_1 = LkA_8 \quad (16)$$

$$A_2 = -LkA_7 \quad (17)$$

and, $-A_3 = LkA_6 \quad (18)$

$$-A_4 = -LkA_5 \quad (19)$$

For $x = l$, $i = 0$ for all values of t ,

$$\therefore 0 = A_5 \sin \alpha l \sin kat + A_6 \sin \alpha l \cos kat + A_7 \cos \alpha l \sin kat + A_8 \cos \alpha l \cos kat \quad (B)$$

$$\therefore A_5 \sin \alpha l + A_7 \cos \alpha l = 0$$

$$\therefore A_6 \sin \alpha l + A_8 \cos \alpha l = 0$$

$$\therefore A_7 = -A_5 \tan \alpha l \quad (20)$$

$$\therefore A_8 = -A_6 \tan \alpha l \quad (21)$$

$$\therefore e = LkA_8 \sin \alpha x \sin kat - LkA_7 \sin \alpha x \cos kat - LkA_6 \cos \alpha x \sin kat + LkA_5 \cos \alpha x \cos kat.$$

For $x = 0$, $e = E \sin \omega t$

$$\therefore E \sin \omega t = -LkA_6 \sin kat - LkA_5 \cos kat,$$

$$\therefore E = -LkA_6, \text{ or } A_6 = -\frac{E}{Lk}, A_5 = 0, \text{ and } \omega = k\alpha.$$

From (19) and (19) $A_3 = E$

and $A_4 = 0$

From (20) and (21) $A_7 = 0$

and, $A_8 = \frac{E}{Lk} \tan \alpha l$

From (16) and (17) $A_1 = E \tan \alpha l$

and $A_2 = 0$

Therefore, $A_1 = E \tan \alpha l$

$$A_2 = 0$$

$$A_3 = E$$

$$A_4 = 0$$

$$A_5 = 0$$

$$A_6 = -\frac{E}{Lk}$$

$$A_7 = 0$$

$$A_8 = \frac{E}{Lk} \tan \alpha l$$

$$\therefore e = E \tan \alpha l \sin \alpha x \sin kat + E \cos \alpha x \sin kat$$

and,
$$i = -\frac{E}{Lk} \sin \alpha x \cos k\alpha t + \frac{E}{Lk} \tan \alpha l \cos \alpha x k\alpha t.$$

Substituting,
$$k = \frac{1}{\sqrt{LC}}, \alpha = \frac{\omega}{k} = \omega\sqrt{LC}$$

$$e = E[\tan \omega l \sqrt{LC} \sin \omega\sqrt{LC} x \sin \omega t + \cos \omega\sqrt{LC} x \sin \omega t],$$

$$i = \frac{E}{LK}[\tan \omega l \sqrt{LC} \cos \omega\sqrt{LC} x \cos \omega t - \sin \omega\sqrt{LC} x \cos \omega t],$$

or,

$$e = E \sin \omega t [\tan \omega l \sqrt{LC} \sin \omega\sqrt{LC} x + \cos \omega\sqrt{LC} x],$$

$$i = E\sqrt{\frac{C}{L}} \cos \omega t [\tan \omega l \sqrt{LC} \cos \omega\sqrt{LC} x - \sin \omega\sqrt{LC} x],$$

or,

$$e = E \sin \omega t \frac{\cos \omega\sqrt{LC} (l - x)}{\cos \omega\sqrt{LC} l} \tag{22}$$

$$i = E\sqrt{\frac{C}{L}} \cos \omega t \frac{\sin \omega\sqrt{LC} (l - x)}{\cos \omega\sqrt{LC} l} \tag{23}$$

The voltage at the end of the line is:

$$e = \frac{E \sin \omega t}{\cos \omega\sqrt{LC} l} \tag{24}$$

Example.—If the receiver voltage, instead of the generator e.m.f. is known and if the distance had been counted from the receiving end of the line, then

$$i = 0, \text{ for } x = 0$$

and,

$$\frac{\partial e}{\partial x} = +L \frac{\partial i}{\partial t}.$$

Thus the signs for A_5, A_6, A_7 and A_8 , in equation (A) would have been reversed.

$$\therefore A_1 = -A_8 Lk.$$

$$A_2 = +A_7 Lk.$$

$$A_3 = LkA_6.$$

$$A_4 = -LkA_5.$$

Equation (B) would have been:

$$0 = A_7 \sin k\alpha t + A_8 \cos k\alpha t, \therefore A_7 \text{ and } A_8 = 0$$

$$\therefore e = LkA_6 \cos \alpha x \sin k\alpha t - LkA_5 - \cos \alpha x \cos k\alpha t$$

For $c = 0, e = E_0 \sin \omega t.$

$$\therefore E_0 = \sin \omega t = LkA_6 \sin k\alpha t - LkA_5 \cos k\alpha t,$$

$$\therefore E_0 = LkA_6, \text{ and } A_5 = 0 \text{ and } \alpha t = \omega t$$

$$\therefore e = E_0 \cos \alpha x \sin k\alpha t$$

$$i = \frac{E_0}{Lk} \sin \alpha x \cos k\alpha t$$

$$\text{or, } e = E_0 \cos \omega \sqrt{LC} \times \sin \omega t \quad (25)$$

$$i = E_0 \sqrt{\frac{C}{L}} \sin \omega \sqrt{LC} \times \cos \omega t \quad (26)$$

Therefore the generator voltage is:

$$e = \cos \omega \sqrt{LC} l E_0 \sin \omega t = E \sin \omega t,$$

$$\therefore E_0 = \frac{E}{\cos \omega \sqrt{LC} l},$$

and (25) becomes:

$$e = E \sin \omega t \frac{\cos \omega \sqrt{LC} x}{\cos \omega \sqrt{LC} l},$$

which is obviously identical with (23) as obtained before.

It is seen at once that the receiver voltage is

$$\frac{1}{\cos \omega \sqrt{LC} l}$$

times that of the generator e.m.f. As the cosine is always less than unity except $l = 0$, the receiver voltage is always greater than the generator e.m.f.

Therefore the receiver voltage would approach infinity, when

$$\omega \sqrt{LC} l = \frac{\pi}{2}$$

or,

$$2\pi f \sqrt{LC} l = \frac{\pi}{2}$$

or,

$$f = \frac{1}{4 \sqrt{LC} l} = \frac{1}{4 \sqrt{(Ll)(Cl)}} = \frac{1}{4 \sqrt{L_0 C_0}}$$

that is, when the natural frequency of the line and the frequency of the impressed e.m.f. coincide.

$$\text{The wave length is } \lambda = \frac{2\pi}{\omega \sqrt{L_0 C_0}}$$

$$\text{Thus the velocity of propagation} = \frac{\lambda}{T} = \frac{2\pi f}{\omega \sqrt{L_0 C_0}} = \frac{1}{\sqrt{L_0 C_0}}$$

If the inductance inside of the conductor is negligible, then the velocity becomes that of light = 188,000 miles per second. In reality it is somewhat less.

So for instance in a transmission line consisting of No. 0 B. & S. wires, 18 in. apart,

$$L = 1.6 \times 10^{-3} \text{ henrys per mile.}$$

$$C = 0.019 \times 10^{-6} \text{ farads per mile.}$$

Then

$$\frac{1}{\sqrt{LC}} = 182,000 \text{ miles per sec.}$$

For short distances,

$$\begin{aligned} \sin \omega \sqrt{LC} x &= \omega \sqrt{LC} x \\ \cos \omega \sqrt{LC} x &= 1 \\ \therefore e &= E_0 \sin \omega t \\ i &= E_0 \sqrt{\frac{C}{L}} \omega \sqrt{LC} x \cos \omega t \\ &= E_0 C \omega x \cos \omega t = \frac{E_0}{x_c} \cos \omega t \end{aligned}$$

where x_c is the capacity reactance of length α of the cable. It is seen that the current in time phase leads the voltage by 90° .

Transient Condition.—When a steady voltage is impressed upon the circuit.

DR. FRANKLIN in his book on waves and his paper before the A. I. E. E. of April, 1914, has approached the subject from a most simple and instructive point of view and has been able to make some generalizations which are of great value.

He shows that whatever the distribution of the current or e.m.f. in a travelling wave along a transmission line there must be a fixed ratio between the instantaneous values, which ratio is $\sqrt{\frac{C}{L}}$ when the line resistance and leakage reactance are negligible, and it can be represented by a somewhat more complicated expression when they are taken into consideration.

His reasoning is briefly as follows:

If the current in an element of the line is i the magnetic flux in the area a, b, c, d , Fig. 53, is $Lidx$.

If the current wave progresses toward the right with a velocity V the time required for the flux to sweep past bc is $\frac{dx}{V}$; thus the e.m.f. induced along bc is $\frac{Lidx}{\frac{dx}{V}} = LiV$.

Similarly if e' is the voltage in the line element then the charge on ab is $e' C dx$.

This charge flows past the point in time $\frac{dx}{V'}$, where V' is the velocity of propagation of the e.m.f. distribution; thus

$$i' = \frac{Q}{t} = e \frac{C dx}{\frac{dx}{V'}} = Ce' V'$$

In order then that these distributions shall sustain each other, $i = i'$, $e = e'$ and $V = V'$.

$$\therefore e = LiV \text{ and } i = CeV$$

or

$$V = \frac{1}{\sqrt{LC}}$$

and

$$Ce^2 = Li^2 \text{ or, } \frac{i}{e} = \pm \sqrt{\frac{C}{L}}$$

The + sign belonging to outgoing waves, and the - sign to the reflected waves.

$$\therefore \frac{i}{e} = +\sqrt{\frac{C}{L}} \text{ and } \frac{i'}{e'} = -\sqrt{\frac{C}{L}} \text{ or } \frac{i}{e} = -\frac{i'}{e'}$$

where index ' refers to the reflected waves.

When the line is open at the receiving end the sum of the incoming and reflected current waves must be zero, thus $i + i' = 0$ or $i' = -i$.

$$\therefore e' = -i' \frac{e}{i} = +\frac{i}{i} e = +e \quad \therefore \frac{e'}{i'} = +\frac{e}{-i}$$

When the line is short-circuited at the receiving end, $e + e' = 0$ $\therefore e' = -e$. Thus $i' = i$.

When the receiving circuit is non-inductive and of resistance R ,

$$e + e' = R(i + i')$$

but

$$\frac{e}{i} = \sqrt{\frac{L}{C}} = a = -\frac{e'}{i'}$$

substituting these values above, then,

$$e' = e \frac{(R - a)}{R + a} \text{ and } i' = i \frac{a - R}{a + R}$$

It is seen that the reflected current and e.m.f. waves may be positive, zero, or negative, depending upon the relative values of R and $\sqrt{\frac{L}{C}}$

In DR. FRANKLIN'S American Institute Paper (April, 1914) is given a very full discussion of the nature of these reflected waves and some highly instructive diagrams are shown.

For example, when the receiving circuit is inductive the line acts at the instant of reflection as if it were open circuited, since the current can not rise instantaneously in an inductive circuit. After some time the condition becomes that of a non-inductive

receiving circuit, discussed above (since we are dealing with direct-current voltage). Between the two periods of time the current and e.m.f. change according to a simple exponential law.

Of special interest is the condition of the waves when the line constants change. DR. FRANKLIN illustrates this condition in the case of an overhead line connected to a cable system.

Let i , i_r and i_t be the instantaneous values of the outgoing current, the reflected current and the transmitted current, and let e , e_r and e_t be the corresponding values of the e.m.f.

Then

$$e + e_r = e_t$$

$$i + i_r = i_t$$

$$\frac{e}{i} = -\frac{e_r}{i_r} = a \frac{e_t}{i_t} = b$$

From these equations are found

$$e_r = \frac{b - a}{b + a} e$$

$$i_r = \frac{a - b}{a + b} i$$

$$e_t = \frac{2b}{a + b} e$$

$$i_t = \frac{2a}{a + b} i$$

It is of interest to apply these simple relations numerically.

Assume that the inductance and the capacity of a cable supplying power to an overhead line are: $L = 0.0002$ henrys and $C = \frac{0.8}{10^6}$ farads per mile, and that the corresponding constants for the overhead line are $L_1 = 0.0015$ henrys and $C_1 = \frac{0.02}{10^6}$ farads per mile.

$$\therefore a = \sqrt{\frac{0.0002}{0.0000008}} = \sqrt{250} = 15.8$$

and

$$b = \sqrt{\frac{0.0015}{0.00000002}} = \sqrt{75,000} = 274$$

If therefore such cable-overhead line combination is connected to a source of steady e.m.f., e , the voltage at the junction as the wave reaches it will be $e_t = \frac{548}{289.8} = 1.88$ times that at the

generator. Should the overhead line be open at the receiving end the voltage will be doubled as the reflected wave starts on its journey back. Thus as a maximum at the junction the voltage would equal 3.76 times the impressed value.

The mathematical solution of the problem is given in equation (11) which can be written in the following way:

$$e = K + \Sigma A \sin (\pm \alpha x + k\alpha t + \gamma) \quad (27)$$

where

$$k = \frac{1}{\sqrt{LC}}$$

$+\alpha$ applies to the waves issuing from the generator and $-\alpha$ to those going toward it. From the expression $\pm \alpha x + k\alpha t$, it is seen that the waves of all frequencies travel with the same velocity, $+k$ or $-k$ where the signs indicate the direction of motion.

It will be shown that in the case of an open line connected to a source (of negligible resistance) of unidirectional voltage, four waves have to be considered before the cycle repeats itself.

First the outgoing rectangular wave of value E which begins at the generator progresses toward the open end of the line. Second the reflected wave also of strength E which returns from the open end toward the generator which with the initial wave gives a wave of double voltage. Third a negative wave of strength $-E$ which progresses from the generator toward the open end of the line, which wave is necessary in order to maintain the generator voltage E . Fourth the reflected wave of the negative wave which is of strength $-E$ and which progresses toward the generator.

Consider now what happens at a point located say at one-fourth of the length of the line from the generator.

If the time required for the wave to reach the end of the line is T , it is evident that during $\frac{1}{4}T$ there is no voltage at the point. After that time the voltage remains constant at a value E until the first reflected wave arrives. This occurs evidently when $t = 1\frac{3}{4}T$. Thus between $t = \frac{T}{4}$ and $t = 1.75T$ the voltage at the point is E .

From that on it has a value of $2E$ until the negative generator wave reaches the point which occurs when $t = 2T + \frac{T}{4} = 2.25T$. After that time the voltage has a value of $2E -$

$E = E$ until the reflected wave of the negative wave arrives which is when $t = 4T - \frac{T}{4} = 3.75T$. Then the voltage = $2E - 2E = 0$, and it remains zero until a time $t = 4.25T$ when the voltage again equals E and the cycle is repeated.

The result is the wave shown in Fig. 54.

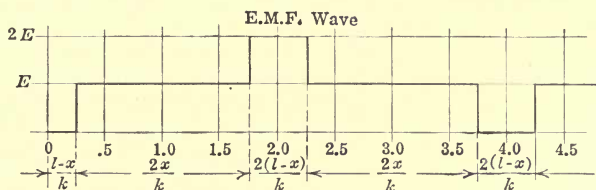

FIG. 54.

A train of waves would pass the point indefinitely since we have neglected the energy loss in resistance. The wave length is evidently four times that of the open line.

Consider now the current wave of Fig. 55.

As successive equal elements of the line are being charged to voltage E a constant current has been shown to flow from the generator while the voltage wave progresses toward the end of

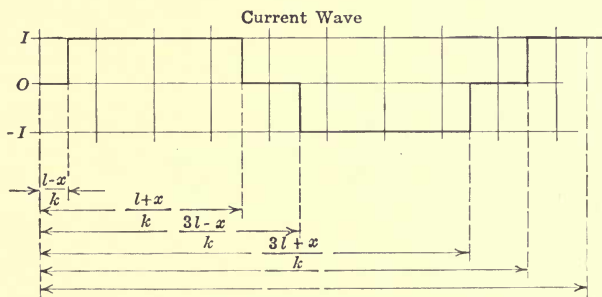

FIG. 55.

the line. At the end the current must be zero, therefore the reflected current wave must be equal but opposite to the incoming wave. The reversed current reaches the generator after a time $2T$, when the current becomes zero. After that time the generator supplies $-E$ voltage and a negative wave of current flows until it also is neutralized by the reflected current which occurs when $t = 4T$.

Consider the current at the particular point mentioned above.

From $t = 0$ to $t = \frac{T}{4}$ no current flows. After that the current is constant until the reflected current reaches the point (at $t = 1.75T$) when it drops to zero. It remains zero until the negative current issuing from the generator reaches the point (at $t = 2T + \frac{T}{4}$). Then it becomes negative and remains negative until the negative reflected current—now positive—reaches the point ($t = 4T - \frac{T}{4}$), when it again is zero—and so forth.

In general centering our mind on a particular point x , from the receiving end of the line there is no e.m.f. or current at that point until $t = \frac{l-x}{k}$. After this the voltage is E , the generator voltage for some time. At $t = \frac{l}{k}$, the waves reach the end of the line and reflect, therefore after $t = \frac{l+x}{k}$, $e = 2E$ for a period of time. At $t = \frac{2l}{k}$, the waves return to the generator end. In order to keep the voltage at the generator end constant at E the generator must now begin to supply $-E$. Therefore after time $t = \frac{3l-x}{k}$, e at x becomes $2E - E = E$; and after $t = \frac{3l+x}{k}$, e at x becomes $2E - 2E = 0$. At $t = \frac{4l}{k}$ the generator reverses its voltage from $-E$ to $+E$ again, and the voltage at x repeats its cycle again and again.

Referring now to equation (27)

$$e = K + \Sigma A \sin(\alpha x + kat + \gamma) + \Sigma A' \sin(-\alpha x + kat + \gamma') \quad (28)$$

when $x = l$, $e = E$ for all values of t .

$$\begin{aligned} \therefore \Sigma A &= \Sigma A' \text{ and } \sin(\alpha l + \gamma) = -\sin(\alpha l + \gamma') \\ &= \sin(n\pi - \alpha l + \gamma') \text{ thus } \alpha = \frac{\gamma' - \gamma + n\pi}{2l} \end{aligned}$$

where $n =$ is an odd number

(29)

and

$$K = E$$

$$\therefore e = E + \Sigma A [\sin(\alpha x + kat + \gamma) + \sin(-\alpha x + kat + \gamma')] \quad (30)$$

At the receiving end of the line ($x = 0$).

$$e = 0 \text{ for all values of } t \text{ which are less than } \frac{l}{k}.$$

But when $t = \frac{l}{k}$ the voltage is $2E$.

Thus $t = \frac{l}{k}$ is a transition point, a point of discontinuity, e is either 0 or $2E$. Substituting the two values in equation (30) we get:

$$\mp E = \Sigma A [\sin (\alpha l + \gamma) + \sin (\alpha l + \gamma')] \text{ respectively} \quad (31)$$

At the open end of the line where there is complete reflection the incoming and outgoing waves are identical

$$\therefore \gamma = \gamma'.$$

Thus from (29) $\alpha = \frac{n\pi}{2l}$ where n is an odd number.

$$\therefore (31) \text{ becomes } \mp E = 2 \Sigma A \sin \left(\frac{n\pi}{2} + \gamma \right) \quad (32)$$

In the development of the trigonometric series it is found that:

$$\mp 1 = \frac{4}{\pi} \sum_{n=l \text{ odd}}^{n=\infty} \frac{\sin n\theta}{n} \text{ where } n \text{ is an odd number} \quad (33)$$

where the negative sign refers to values of θ between π and 2π and the positive sign to values between 0 and π or $\pi < \theta < 2\pi$ for negative sign. $0 < \theta < \pi$ for positive sign.

See "BYERLY'S FOURIER'S Series and Spherical Harmonics" (page 51). Comparing equations (32) and (33) it is evident that:

$$A_n = \frac{E}{2} \frac{4}{\pi} \frac{1}{n}$$

and

$$\frac{n\pi}{2} + \gamma = n\theta.$$

It remains to determine the value of θ . The two series have π and 2π or 0 in common. It remains to choose the proper value of these.

If π were chosen the \pm signs in (32) and (33) would be reversed, if however, 0 or 2π is chosen, the signs are satisfied. Thus

$$\frac{n\pi}{2} + \gamma = 2n\pi \text{ or } 0 \quad \therefore \gamma = -\frac{n\pi}{2}$$

Thus equation (30) becomes:

$$e = E + \frac{E}{2} \frac{4}{\pi} \sum \frac{1}{n} \left[\sin \frac{n\pi}{2l} (x + kt - l) + \sin \frac{n\pi}{2l} (-x + kt - l) \right] \quad (34)$$

and since

$$\frac{\partial e}{\partial x} = L \frac{di}{dt}$$

$$i = \frac{E}{2} \sqrt{\frac{C}{L}} \sum \frac{1}{n} \left[\sin \frac{n\pi}{2l} (x + kt - l) - \sin \frac{n\pi}{2l} (-x + kt - l) \right] \quad (35)$$

The curves drawn in Figs. 54 and 55 may be verified as follows:

$$x = \frac{3l}{4}$$

$$\text{for } t < \frac{l-x}{k}$$

$$x + kt - l < x + l - x - l \text{ or smaller than } 0$$

$\therefore \theta$ in the trigonometric series lies between π and 2π .

$$\text{Therefore } \sum \frac{1}{n} \sin (x + kt - l) = -\frac{\pi}{4}.$$

Consider with the second term in (34), $-x + kt - l < -x + l - x - l$, thus smaller than $-2x$ or smaller than $-2 + \frac{3l}{4}$ or $-1.5l$ thus θ is again negative and the series of the second term in (35) adds up to $-\frac{\pi}{4}$

$$\therefore e = E + \frac{E}{2} \frac{4}{\pi} \left(-\frac{\pi}{4} - \frac{\pi}{4} \right) = 0 \text{ which agrees with the curve.}$$

$$\text{When } t = \frac{k}{l} \quad x + kt - l = x + l - l = x = \frac{3l}{4}$$

we are in the first quadrant

$$\therefore \sum \frac{1}{n} \sin (x + kt - l) = +\frac{\pi}{4}$$

$$\text{and } -x + kt - l = -x + l - l = -x = -\frac{3}{4}l.$$

θ lies in the fourth quadrant

$$\therefore \sum \frac{1}{n} \sin (-x + kt - l) = -\frac{\pi}{4}$$

$$\therefore e = E \text{ which agrees with the curve.}$$

$$\text{For } t = \frac{2l}{k} \quad x + kt - l = x + 2l - l = x + l = 1.75l.$$

θ lies in the second quadrant, thus:

$$\sum \frac{1}{n} \sin (x + kt - l) = +\frac{\pi}{4}$$

and $-x + kt - l = -x + l = 0.25l$.

θ lies in the first quadrant, thus:

$$\sum \frac{1}{n} \sin(-x + kt - l) = + \frac{\pi}{4}$$

$\therefore e = 2E$ which agrees with the curve.

The current wave may similarly be checked. When for instance $t = \frac{l}{k}$, it is readily seen that the algebraic sum of the trigonometric terms become $\frac{\pi}{4}$

$$\therefore i = \frac{E}{2} \frac{4}{\pi} \sqrt{\frac{C}{L}} \frac{\pi}{2} = E \sqrt{\frac{C}{L}} \text{ which agrees with the curve.}$$

It is thus seen that when considering the outgoing waves only the relation between the current and e.m.f. waves must be $\frac{i}{e} = \sqrt{\frac{C}{L}}$, the equation also shows that when considering the reflected waves

$$\frac{i'}{e'} = - \sqrt{\frac{C}{L}}$$

The effect of the line resistance is to taper the waves so that instead of their being represented as a ribbon of parallel sides the sides slant toward each other; thus the reflected e.m.f. wave is not as great as the original wave, and the line soon reaches a state of permanent condition.

In reality the wave front is not vertical but slants and the corner is rounded off, due to the skin effect of the conductors. The higher harmonics of the current meet a much higher resistance than do the lower, and hence the resistance is not a constant quantity but different resistances should be assumed in connection with the different harmonics.

The mathematics involved becomes, however, altogether too complicated for any practical application. The important point is that if the values of the waves are determined in a circuit having no resistance, the most pronounced variations in current and e.m.f. are discovered.

A circuit having no resistance and no leakage is said to produce pure waves the characteristics of which are, as has been shown, such that

$$\frac{1}{2}Ce^2 = \frac{1}{2}Lc^2$$

That is the electric energy is always equal to the magnetic energy.

The wave may, however, be pure even if there is resistance and leakage but in that case the energy dissipated in heat per unit length of line must be equal to the energy dissipated by leakage in the electric field.

$\therefore i^2 R = \frac{e^2}{R_1}$ where R_1 is the leakage resistance per unit length.

$$\therefore RR_1 = \frac{e^2}{i^2} = \frac{L}{C}$$

A line in which this relation exists is called a distortionless line.

For a full discussion of such circuit the reader is again referred to DR. FRANKLIN'S book on waves.

CHAPTER IX

DISTRIBUTED RESISTANCE, INDUCTANCE, LEAKAGE, CONDUCTANCE AND CAPACITY

Let R , L , G and C , Fig. 56, be the line constants per unit length of the line, R being expressed in ohms, L in henrys, G in ohms and C in farads.

The voltage equation is evidently

$$\frac{\partial e}{\partial x} dx = R dx i + L dx \frac{\partial i}{\partial t}$$

or,

$$\frac{\partial e}{\partial x} = Ri + L \frac{\partial i}{\partial t} \tag{1}$$

$$\frac{\partial i}{\partial x} dx = G dx e + C dx \frac{\partial e}{\partial t}$$

or,

$$\frac{\partial i}{\partial x} = Ge + C \frac{\partial e}{\partial t} \tag{2}$$

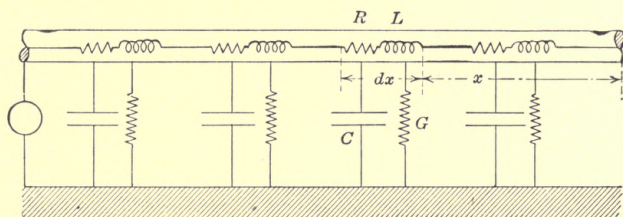

FIG. 56.

Differentiating (1) partially with respect to x and (2) with respect to t and combining the results with (1) and (2) we get:

$$\frac{\partial^2 e}{\partial x^2} = LC \frac{\partial^2 e}{\partial t^2} + (RC + GL) \frac{\partial e}{\partial t} + RGe \tag{3}$$

and,

$$\frac{\partial^2 i}{\partial x^2} = LC \frac{\partial^2 i}{\partial t^2} + (RC + GL) \frac{\partial i}{\partial t} + RGi \tag{4}$$

The general solution of these equations is

$$\Sigma A e^{\alpha' x + \beta' t}$$

where α' and β' may be positive or negative, real or imaginary, simple or complex.

Substituting the general solution in (3) or (4) and equating the coefficient, we get

$$\alpha'^2 = LC\beta'^2(RC + GL)\beta' + RG \quad (5)$$

Substituting $a + j\alpha$ for α' and $b + j\beta$ for β' in (5) and separating the real and imaginary terms, we have

$$a^2 - \alpha^2 = LC(b^2 - \beta^2) + (RC + GL)b + RG \quad (6)$$

and

$$2a\alpha = 2LCb\beta + (RC + GL)\beta \quad (7)$$

A slight consideration shows that the exponential solution given above can be written

$$e = k + \Sigma A\epsilon^{\pm ax \pm bt} \sin(\beta t \pm \alpha x + \gamma) \quad (8)$$

If now for the sake of simplicity only the *permanent* condition is considered we get

$$e = k + \Sigma A\epsilon^{\pm ax} \sin(\beta t \pm \alpha x + \gamma) \quad (9)$$

If as a further limitation the current and e.m.f. are assumed to be simple sine functions, depending in time upon the impressed frequency, then β has only one value ω . From (6) and (7) follows then that only two values of α and a exist, one being positive the other negative

$$\therefore e = A_1\epsilon^{ax} \sin(\beta t + \alpha x + \gamma_1) + A_2\epsilon^{-ax} \sin(\beta t - \alpha x + \gamma_2) \quad (10)$$

In this equation, one term represents the sum of the outgoing, the other the sum of the incoming waves.

If the line is open at the receiving end then the beginning value of the reflected waves must be identical with the final value of the incoming waves when $x = 0$.

Thus under this condition for $x = 0$

$$A_1 \sin(\beta t + \gamma_1) = A_2 \sin(\beta t + \gamma_2)$$

Since this must hold for all values of t

$$\therefore \gamma_1 = \gamma_2 \text{ and } A_1 = A_2$$

If the voltage at the generator end is $E \sin \omega t$, then

$$E = \sin \omega t = A_1[\epsilon^{al} \sin(\beta t + \alpha l + \gamma_1) + \epsilon^{-al} \sin(\beta t - \alpha l + \gamma_1)]$$

which by simple transformation becomes

$$\begin{aligned} E \sin \omega t &= A_1 \left\{ \sin \beta t [\epsilon^{al} \cos(\alpha l + \gamma_1) + \epsilon^{-al} \cos(-\alpha l - \gamma_1)] \right. \\ &\quad \left. + \cos \beta t [\epsilon^{al} \sin(\alpha l + \gamma_1) + \epsilon^{-al} \sin(-\alpha l + \gamma_1)] \right\} \\ &= A_1 \sqrt{\epsilon^{+2al} + \epsilon^{-2al} + 2(\cos^2 \alpha l - \sin^2 \alpha l)} \sin(\beta t + \theta) \end{aligned}$$

where $\tan \theta = \frac{\epsilon^{al} \sin (\alpha l + \gamma_1) + \epsilon^{-al} \sin (-\alpha l + \gamma_1)}{\epsilon^{al} \cos (\alpha l + \gamma_1) + \epsilon^{-al} \cos (-\alpha l + \gamma_1)}$

Thus $\beta = \omega$ and $\theta = 0$

$$\therefore A_1 = \frac{E}{\sqrt{\epsilon^{2al} + \epsilon^{-2al} + 2(\cos^2 \alpha l - \sin^2 \alpha l)}}$$

Since $\theta = 0$

$$\epsilon^{al} \sin (\alpha l + \gamma_1) + \epsilon^{-al} \sin (-\alpha l + \gamma_1) = 0$$

which gives $\gamma_1 = \tan^{-1} - \frac{\epsilon^{al} - \epsilon^{-al}}{\epsilon^{al} + \epsilon^{-al}} \tan \alpha l$

Equation (10) is now completely determined.

$$\begin{aligned} \frac{C \partial e}{\partial t} + Ge &= A_1 \{ C\omega [\epsilon^{ax} \cos (\omega t + \alpha x + \gamma_1) + \epsilon^{-ax} \cos (\omega t - \alpha x + \gamma_1) \\ &\quad + G [\epsilon^{ax} \sin (\omega t + \alpha x + \gamma_1) + \epsilon^{-ax} \sin (\omega t - \alpha x + \gamma_1)] \} \\ &= A_1 \sqrt{C^2 \omega^2 + G^2} [\epsilon^{ax} \sin (\omega t + \alpha x + \gamma_1 + \varphi) + \\ &\quad \epsilon^{-ax} \sin (\omega t - \alpha x + \gamma_1 + \varphi)] \end{aligned} \quad (11)$$

where

$$\varphi = \tan^{-1} \frac{C\omega}{G}$$

Let i now be the permanent component of the current, and assume:

$$\begin{aligned} i &= B_1 \epsilon^{ax} \sin (\omega t + \alpha x + \varphi_1) + B_2 \epsilon^{-ax} \sin (\omega t - \alpha x + \varphi_2) \quad (12) \\ \frac{\partial i}{\partial x} &= B_1 a \epsilon^{ax} \sin (\omega t + \alpha x + \varphi_1) - B_2 a \epsilon^{-ax} \sin (\omega t - \alpha x + \varphi_2) \\ &\quad + B_1 a \epsilon^{ax} \cos (\omega t + \alpha x + \varphi_1) - B_2 a \epsilon^{-ax} \cos (\omega t - \alpha x + \varphi_2) \\ &= \sqrt{\alpha^2 + a^2} [B_1 \epsilon^{ax} \sin (\omega t + \alpha x + \varphi_1 + \sigma) \\ &\quad - B_2 \epsilon^{-ax} \sin (\omega t - \alpha x + \varphi_2 + \sigma)] \end{aligned} \quad (13)$$

where

$$\sigma = \tan^{-1} \frac{\alpha}{a}$$

According to (2), (11) and (13) must be identical, and hence,

$$\begin{aligned} \sqrt{\alpha^2 + a^2} B_1 &= -\sqrt{\alpha^2 + a^2} B_2 = \sqrt{C^2 \omega^2 + G^2} A_1, \\ \varphi_1 + \sigma &= \gamma_1 + \varphi, \varphi_2 + \sigma = \gamma_1 + \varphi, \therefore \varphi_1 = \varphi_2 = \gamma_1 + \varphi - \sigma \end{aligned}$$

To sum up,

$$e = \frac{E [\epsilon^{ax} \sin (\omega t + \alpha x + \varphi_1) + \epsilon^{-ax} \sin (\omega t - \alpha x + \varphi_1)]}{\sqrt{\epsilon^{2al} + \epsilon^{-2al} + 2(\cos^2 \alpha l - \sin^2 \alpha l)}} \quad (14)$$

$$\begin{aligned} i &= E \sqrt{\frac{C^2 \omega^2 + G^2}{\alpha^2 + a^2}} \\ &\quad \frac{[\epsilon^{ax} \sin (\omega t + \alpha x + \gamma_1) - \epsilon^{-ax} \sin (\omega t - \alpha x + \gamma_1)]}{\sqrt{\epsilon^{2al} + \epsilon^{-2al} + 2(\cos^2 \alpha l - \sin^2 \alpha l)}} \end{aligned} \quad (15)$$

where

$$\gamma_1 = \tan^{-1} \left[\frac{\epsilon^{al} - \epsilon^{-al}}{\epsilon^{al} + \epsilon^{-al}} \tan \alpha l \right]$$

$$\sigma = \tan^{-1} \frac{\alpha}{a}$$

$$\varphi = \tan^{-1} \frac{C\omega}{G}$$

$$\varphi_1 = \varphi + \gamma_1 - \sigma$$

and,

$$a = + \sqrt{+ \sqrt{\left(\frac{R^2 + L^2\omega^2}{2}\right) \left(\frac{G^2 + C^2\omega^2}{2}\right) + \frac{RG - LC\omega^2}{2}}} \quad (16)$$

$$\alpha = + \sqrt{+ \sqrt{\left(\frac{R^2 + L^2\omega^2}{2}\right) \left(\frac{G^2 + C^2\omega^2}{2}\right) - \frac{RG - LC\omega^2}{2}}} \quad (17)$$

the latter two values being determined from (6) and (7) by letting $b = 0$ and $\beta = \omega$.

These solutions apply when the transient terms become negligible, *i.e.*, when t is large enough to make ϵ^{-bt} comparatively small.

Case (b).—Direct-current distribution in an open line. Consider the line open as before. For the permanent component of the solution, *i.e.*, a solution which applies after the line has been switched to the generator for a sufficient length of time, the equation can be derived as follows:

Referring to equations (6) and (7), b is zero, when only the permanent component is considered, and β is also zero, as there exists no periodic phenomenon, when the impressed voltage is constant and when the starting phenomenon is reduced to negligible magnitude.

Substituting $b = 0$ and $\beta = 0$ in (6) and (7) we get:

$$a^2 - \alpha^2 = RG \text{ and } 2a\alpha = 0,$$

from the latter, either a or α must be zero, while from the former a can not be zero, since α itself must not be imaginary.

$$\therefore \alpha = 0 \text{ and } a = \pm \sqrt{RG}.$$

Let e' be the permanent component of the voltage and assume:

$$e' = A_1\epsilon^{ax} + A_2\epsilon^{-ax} \quad (18)$$

where $x = l$, $e' = E$

$$\therefore E = A_1\epsilon^{al} + A_2\epsilon^{-al} \quad (19)$$

Let i be the permanent component of the current. According to (2),

$$\frac{\partial i}{\partial x} = C \frac{\partial e'}{\partial t} + Ge' \quad (20)$$

Substituting (18) and (20)

$$\frac{\partial i'}{\partial x} = 0 + G(A_1 \epsilon^{ax} + A_2 \epsilon^{-ax}).$$

Integrating,
$$i' = \frac{G}{a} (A_1 \epsilon^{ax} - A_2 \epsilon^{-ax}) + K \quad (21)$$

According to (1)
$$\frac{\partial e'}{\partial x} = Ri + L \frac{\partial i'}{\partial t} \quad (22)$$

Substituting (18) and (21) in (2),

$$a(A_1 \epsilon^{ax} - A_2 \epsilon^{-ax}) = \frac{RG}{a} (A_1 \epsilon^{ax} - A_2 \epsilon^{-ax}) + RK.$$

Since $a^2 = RG$, $K = 0$, and (21) becomes:

$$i = \frac{G}{a} (A_1 \epsilon^{ax} - A_2 \epsilon^{-ax})$$

where

$$x = 0, i' = 0, \therefore A_1 = A_2.$$

From (19)

$$A_1 = A_2 = \frac{E}{\epsilon^{al} + \epsilon^{-al}}.$$

Therefore,

$$e' = E \frac{\epsilon^{ax} + \epsilon^{-ax}}{\epsilon^{al} + \epsilon^{-al}} \quad (23)$$

$$i = E \sqrt{\frac{G}{R}} \frac{\epsilon^{ax} - \epsilon^{-ax}}{\epsilon^{al} - \epsilon^{-al}} \quad (24)$$

where $a = +\sqrt{RG}$, these equations apply when the transient terms become negligible.

CHAPTER X

PERMANENT CONDITIONS WHEN ONE OF THE FOUR CONSTANTS, R, L, G, AND C IS NEGLIGIBLE

I. $R = 0.$

Case (a).—Alternating current: The solutions are given by (14) and (15) in the previous chapter, but in this case,

$$a = +\sqrt{\frac{L\omega}{2} [+ \sqrt{C^2\omega^2 + G^2} - C\omega]}$$

and,

$$\alpha = +\sqrt{\frac{L\omega}{2} [+ \sqrt{C^2\omega^2 + G^2} + C\omega]}.$$

Case (b).—Direct current: Referring to (23) and (24) in the previous chapter,

$$a = \sqrt{RG} = 0$$

$$\therefore e' = E.$$

Under this condition the equations deduced give $\frac{0}{0}$ in the case of the permanent current. Thus they do not lend themselves to the determination of the current.

II. $G = 0$

Case (a).—Alternating current: With

$$a = +\sqrt{\frac{C\omega}{2} [+ \sqrt{L^2\omega^2 + R^2} - L\omega]},$$

and

$$\alpha = +\sqrt{\frac{C\omega}{2} [+ \sqrt{L^2\omega^2 + R^2} + L\omega]}$$

equations (14) and (15) in the previous chapter give the solution.

Case (b).—Direct current: From (23) and (24) in the previous chapter,

$$e' = E \text{ and } i = 0.$$

III. $L = 0.$

Case (a).—Alternating current: In this case

$$a = +\sqrt{\frac{R}{2} [+ \sqrt{G^2 + C^2\omega^2} + G]}$$

and

$$\alpha = +\sqrt{\frac{R}{2} [+ \sqrt{G^2 + C^2\omega^2} - G]}$$

Case (b).—Direct current:

$$e' = E \frac{\epsilon^{ax} + \epsilon^{-ax}}{\epsilon^{at} + \epsilon^{-at}}$$

and,

$$i = E \sqrt{\frac{G}{R}} \frac{\epsilon^{ax} - \epsilon^{-ax}}{\epsilon^{at} - \epsilon^{-at}} \text{ where } a = +\sqrt{RG}$$

IV.

$$C = 0$$

Case (a).—Alternating current: In this case,

$$a = +\sqrt{\frac{R}{2} [+ \sqrt{G^2 + C^2\omega^2} + G]}$$

and

$$\alpha = +\sqrt{\frac{R}{2} [+ \sqrt{G^2 + C^2\omega^2} - G]}$$

Case (b).—Direct current: Same as III.

CHAPTER XI

THE DISTRIBUTION OF FLUX OR CURRENT IN A CYLINDRICAL OR FLAT CONDUCTOR

The general reasoning and the mathematics involved in the study of flux or current distribution in conductors is very similar to that involved in the study of propagation phenomena in transmission lines. It is therefore included in this part of the book even though it is again and more fully considered in a later chapter, where the subject is approached from a different point of view.

Distribution of Flux in Cylindrical and Flat Bars.—When a cylindrical bar is magnetized by a winding surrounding it, the

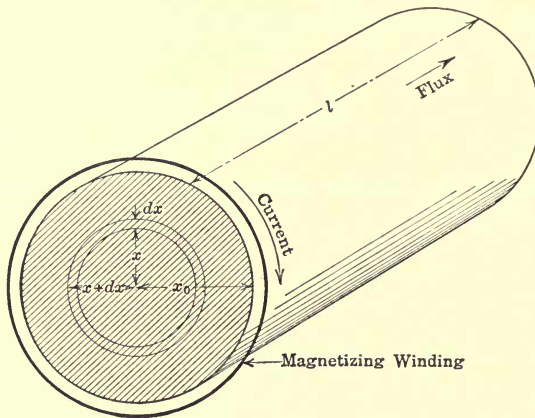

FIG. 57.

flux of final flux density corresponding to the external m.m.f. appears at the surface nearest to the magnetizing winding.

At a distance from the surface of the bar, the flux density is less than that at the surface, because as the flux penetrates the inner layers of the bar, it induces a voltage in the outer layers, which causes a flow of current that produces m.m.f. of a direction more or less in opposition to the external impressed m.m.f.

Referring to Fig. 57, consider a concentric tubular element of

thickness dx and mean radius x , then another of thickness dx but mean radius $x + dx$.

Let ϕ be the flux in the tubular element of radius x , and $\phi + d\phi$ that of radius $x + dx$. Thus $d\phi$ is the increment of flux in the tubular element, as x increases from x to $x + dx$, but the total flux in the tubular element is ϕ .

ϕ is the result of the external m.m.f. and the m.m.f. (demagnetizing) due to the current between x and x_0 ; $\phi + d\phi$ is the result of the external m.m.f. and the m.m.f. due to the current between $x + dx$ and x_0 . Therefore $d\phi$ is caused by the decrement of demagnetizing m.m.f. due to the current between x and $x + dx$, i.e., within dx .

Let i be the current density at x , then the current within dx is $ildx$, and the m.m.f. due to it is also $ildx$, as the number of turns is unity (l being the length of the cylinder).

Let B be the flux density at x then dB the increment of flux density as x increases from x to $x + dx$. Thus $d\phi = 2\pi x dx dB$.

$$\text{Since flux} = 0.4 \pi \frac{\text{m.m.f.}}{\text{reluctance}}$$

$$\text{and the reluctance in this case is } \frac{l}{2\pi \times dx \mu}$$

$$\text{We get } d\phi = 2\pi \times dx \times dB = \frac{0.4\pi ildx}{2\pi \times dx \mu}$$

$$\text{thus } \frac{dB}{dx} = 0.4\pi \mu i \tag{1}$$

If ρ is the spec. resistance

$$\text{then the resistance that the current within } dx \text{ meets is } \int \frac{\rho 2\pi r}{ldx}$$

$$\text{and the e.m.f. consumed by the resistance} = ildx \int \frac{2\pi x}{ldx} = 2\pi \rho x i.$$

Let e be the e.m.f. induced in the circle of radius x , and $e + de$ that in the circle of radius $x + dx$.

As no external e.m.f. is applied around the circle of radius x the sum of the consumed and the induced e.m.f.s. is zero, thus:

$$e + 2\pi \rho x i = 0 \tag{2}$$

Substituting (2) in (1)

$$\frac{dB}{dx} = - \frac{0.4\pi \mu e}{2\pi \rho x} \tag{3}$$

e is induced by all the flux within the circle of radius x , and $e + de$ by all the flux within the circle of radius $x + dx$, thus de is induced by all flux in the tubular element $2\pi x dx$, which is ϕ according to our notation. Hence $de = -\frac{1}{10^8} \frac{d\phi}{dt}$ or using partial differentials,

$$\partial e = -\frac{1}{10^8} \frac{\partial \phi}{\partial t}$$

or

$$\partial e = -\frac{1}{10^8} \frac{0.2\pi x \partial x \partial B}{\partial t}$$

or,

$$\frac{\partial e}{\partial x} = -\frac{2\pi x}{10^8} \frac{\partial B}{\partial t} \quad (4)$$

Equation (3) may be written:

$$x \frac{\partial B}{\partial x} = -\frac{0.4\pi\mu}{2\pi\rho} e.$$

Differentiating with respect to x ,

$$x \frac{\partial^2 B}{\partial x^2} + \frac{\partial B}{\partial x} = -\frac{0.4\pi\mu}{2\pi\rho} \frac{\partial e}{\partial x} \quad (5)$$

Combining (4) and (5), dividing by x

$$\frac{\partial^2 B}{\partial x^2} + \frac{1}{x} \frac{\partial B}{\partial x} = \frac{0.4\pi\mu}{10^8\rho} \frac{\partial B}{\partial t} \quad (6)$$

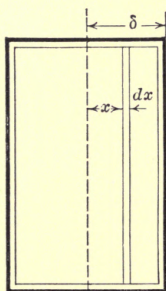

Winding
FIG. 58.

A long thin flat bar may be considered as a cylindrical bar of infinitely small curvature or infinitely large radius, thus x considered as the radius becomes infinity and equation (6) becomes:

$$\frac{\partial^2 B}{\partial x^2} = \frac{0.4\pi\mu}{10^8\rho} \frac{\partial B}{\partial t} \quad (7)$$

while ∂x and x take the meanings as shown in the Fig. 58.

Equation (7) may be directly derived from consideration of a flat bar in place of a cylindrical bar.

Distribution of Current in Cylindrical and Flat Bars.—Reasoning as in the previous paragraph, but considering the current and flux interchanged in their places, not only similar but also identical equations will be derived for the distribution of current.

Let B in Fig. 59 be the flux density at x , i be the current density at x , and $i + di$ the current density at $x + dx$.

The flux in the tubular element dx is $Bldx$.

The reluctance of the flux path is $\frac{2\pi x}{\mu dx}$

Thus since flux = $\frac{0.4\pi \text{ m.m.f.}}{\text{reluctance}}$

$$\text{m.m.f.} = m = \frac{2\pi Bx}{2.4\pi\mu} \tag{8}$$

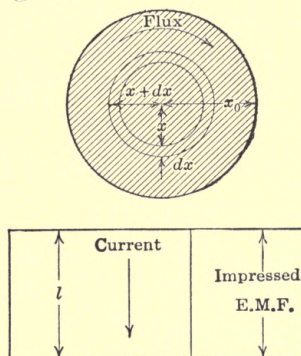

FIG. 59.

As x increases from x to $x + dx$, the m.m.f. increases from what is within the circle of radius x to that of radius $x + dx$

$$dm = 2\pi x dx i, \text{ or } \frac{dm}{dx} = 2\pi x i \text{ where } i \text{ is the current density at distance } x \tag{9}$$

Differentiating (8)

$$\frac{dm}{dx} = \frac{2\pi}{0.4\pi\mu} \left(x \frac{dB}{dx} + B \right) \tag{10}$$

Equating (2) and (3)

$$\frac{dB}{dx} + \frac{B}{x} = 0.4\pi\mu i \tag{11}$$

As x increases from x to $x + dx$, the increment of current density is di , and the increment of current in the tubular element is $2\pi x dx di$. The resistance of the material that this increment of current traverses is $\frac{\rho l}{2\pi x dx}$. Therefore the increment of the consumed e.m.f. is:

$$2\pi x dx di \frac{\rho l}{2\pi x dx} = \rho l di.$$

Hence the decrement of the induced e.m.f., $-de$ is $-\rho l di$. This $-de$ is caused by the flux in the tubular element, viz., $B l dx$. Therefore

$$-de = -\rho l di = -\frac{1}{10^8} \frac{d}{dt} B l dx,$$

using signs of partial differentials, and re-arranging, we have:

$$\frac{di}{dx} = \frac{1}{10^8 \rho} \frac{\partial B}{\partial t} \quad (12)$$

Differentiating (11) with respect to t and (5) to x ,

$$\frac{\partial^2 B}{\partial x \partial t} + \frac{1}{x} \frac{\partial B}{\partial t} = 0.4 \pi \mu \frac{\partial i}{\partial t} \quad (13)$$

and

$$\frac{\partial^2 i}{\partial x^2} = \frac{1}{10^8 \rho} \frac{\partial^2 B}{\partial x \partial t} \quad (14)$$

Substituting (12) and (14) in (13)

$$\frac{\partial^2 i}{\partial x^2} + \frac{1}{x} \frac{\partial i}{\partial x} = \frac{0.4 \pi \mu}{10^8 \rho} \frac{\partial i}{\partial t} \quad (15)$$

For long or thin flat bars,

$$\frac{\partial^2 i}{\partial x^2} = \frac{0.4 \pi \mu}{10^8 \rho} \frac{\partial i}{\partial t} \quad (16)$$

The solution of equation (15) is somewhat difficult and is therefore delayed until later (see Skin Effect in Cylindrical Conductors).

Equation (16), however, which shows the flux distribution in a lamination is readily solved when the impressed m.m.f. and therefore, at least in non-magnetic materials the flux density is a sine function of time.

Let $B = B_m \sin \omega t$

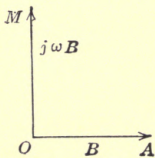

FIG. 60.

$$\therefore \frac{dB}{dt} = B_m \omega \cos \omega t$$

The effective value of the first expression may be represented by vector $OA = B$, and that of the second expression in the derivative by $OM = j\omega B$. See Fig. 60.

Thus dealing now with effective values we can write:

$$\frac{d^2 B}{dx^2} = j0.4 \pi \frac{\mu \omega}{\rho 10^8} B = v^2 B$$

where

$$v^2 = \frac{0.4\pi\mu\omega j}{\rho 10^8}$$

To solve this equation we write,

$$\frac{d^2B}{dx^2} - v^2B = 0 \quad \therefore m^2 - v^2 = 0$$

$$\therefore m = \pm v$$

and

$$B = A_1\epsilon^{vx} + A_2\epsilon^{-vx}$$

Since the density must be the same at equal distances from the center line

$$A_1\epsilon^{vx} + A_2\epsilon^{-vx} = A_1\epsilon^{-vx} + A_2\epsilon^{vx}$$

which requires that $A_1 = A_2 = A$

$$v^2 = \frac{0.4\pi\mu j}{\rho 10^8}$$

It is readily seen that if $v = (1 + j)\alpha$

$$v^2 = 2j\alpha^2$$

$$\therefore \alpha^2 = \frac{v^2}{2j} = \frac{0.2\pi\mu\omega}{\rho 10^8}$$

$$\therefore B = A[\epsilon^{(1+j)ax} + \epsilon^{-(1+j)ax}]$$

or

$$B = A[\epsilon^{ax}\epsilon^{jax} + \epsilon^{-ax}\epsilon^{-jax}]$$

Substituting trigonometric expressions and combining the real and imaginary terms we get:

Since

$$\epsilon^{\pm jax} = \cos ax \pm j \sin ax$$

$$B = A[(\epsilon^{ax} + \epsilon^{-ax}) \cos ax + j(\epsilon^{ax} - \epsilon^{-ax}) \sin ax]$$

If B_1 is the effective value of the surface density then $B = B_1$ for $x = \delta$.

If, furthermore, it is assumed as an approximation that $\epsilon^{-a\delta}$ is small compared with $\epsilon^{a\delta}$ then,

$$B_1 = A\epsilon^{a\delta} (\cos a\delta + j \sin a\delta)$$

and

$$A = \frac{B_1\epsilon^{-a\delta}}{\cos a\delta + j \sin a\delta}$$

$$\therefore B = \frac{B_1\epsilon^{-a\delta}}{\cos a\delta + j \sin a\delta} [(\epsilon^{ax} + \epsilon^{-ax}) \cos ax + j(\epsilon^{ax} - \epsilon^{-ax}) \sin ax]$$

and
$$B = B_1 \epsilon^{-a\delta} \sqrt{\epsilon^{2ax} + \epsilon^{-2ax} + 2 \cos 2ax}$$

where as given above

$$\alpha = \sqrt{\frac{0.2\pi 2\mu\pi f}{\rho 10^8}}.$$

For iron ρ is approximately 10^5 and μ may be anything up to 18,000.

For copper ρ is approximately $\frac{1}{6 \times 10^5}$ and $\mu = 1$.

PART II. PROBLEMS IN ELECTROSTATICS

CHAPTER XII

FUNDAMENTAL LAWS

Coulomb's Law.—The fundamental law upon which our knowledge of electrostatic or electromagnetic phenomena rests was found experimentally by COULOMB. It is similar to NEWTON'S law of gravitation and is:

$$F = c \frac{Q_1 Q_2}{r^2} \text{ or } F = c \frac{m_1 m_2}{r^2} \quad (1)$$

where F is the force acting upon the point charges Q_1 and Q_2 , or the magnet poles of strength m_1 and m_2 , c is a constant depending upon the system of units employed, and r is the distance between the charges or magnet-poles, respectively.

In the electrostatic system of units, as well as in the electromagnetic system of units, c is taken as unity when the medium is air, or rather vacuum,

$$\therefore F = \frac{Q_1 Q_2}{r^2}, \text{ and } F = \frac{m_1 m_2}{r^2} \quad (2)$$

where F is expressed in dynes.

Thus two unit charges or two unit magnet-poles repel each other with a force of 1 dyne when separated 1 cm.

If the medium has a specific inductive capacity K , then

$$F = \frac{1}{K} \cdot \frac{Q_1 Q_2}{r^2}$$

If the magnetic medium has a permeability μ , then

$$F = \frac{1}{\mu} \cdot \frac{m_1 m_2}{r^2}$$

The strength of unit poles is then measured—assuming that it were possible—by the repulsion between two similar poles. When the force is 1 dyne and the distance is 1 cm., the poles have unit strength.

Field Intensity.—Surrounding electric charges or magnet-poles is a field, and the intensity of the field at a point is defined as the property of the space, which is measured by the force exerted by the field on unit charge or unit pole located in that point, when electric and magnetic fields, respectively, are considered.

Because of this definition, it must not be inferred that the intensity of the field is a force; it is not a force, but merely a space function just as the gravitational field intensity is a space function. The force acting on a certain mass at a certain point may have any value, depending upon the particular mass used in the experiment.

Important Theorems.—While COULOMB's law forms the basis on which the theories rest, the progress in the art would probably have been slow were it not that a number of theorems have been worked out more or less directly from that law. These theorems are:

GAUSS's theorem, the divergence theorem, GREEN's and STOKES's theorems, etc., all having important bearing on practical problems.

Surface Integral of a Distributed Vector.—As a preliminary to these theorems the surface integral of a distributed vector will be defined.

It will be assumed that an electric field exists due to some charge and that lines of force or tubes of force radiate from the charge in all directions. It is desired to find the number of lines that go through a surface, say a cap that is placed in the field. In Fig. 61, *AB* may be assumed to be, for instance, the intersection of the plane of a loop of wire, over which the cap is made, with the plane of the paper.

If the surface of the cap were divided up into a number of elements and the direction and the intensity of the field at every point were known, then it obviously would be possible to calculate the total number of lines (the flux) that crosses the cap or the surface.

The sum of the fluxes normal to each element of the surface is called the surface integral of the normal field intensity over the cap, or the total outward flux through the cap. (The normal to the elementary surface is always understood to be drawn outward from the surface. On account of the sign of trigonometric function a normal drawn inward will lead to a negative surface integral.)

If another diaphragm or cap (Fig. 62) were stretched across the wire loop AB , it is evident that a certain amount of flux would enter the space between the diaphragms and a certain amount leave it.

It will be shown in this case that the total normal outward flux from the space enclosed by the two caps will be zero, as long as no charged particles are enclosed by the diaphragms.

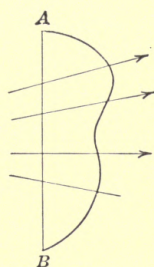

FIG. 61.

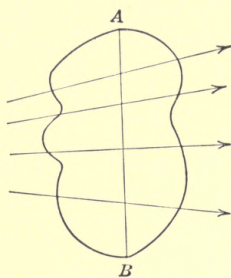

FIG. 62.

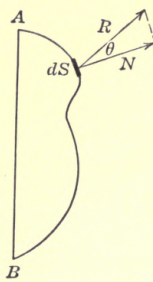

FIG. 63.

Consider then a distributed vector field (Fig. 63), and let R be the value of the vector at the small surface element dS , making an angle θ with the normal to the surface element. R represents the electrostatic or electromagnetic field intensity.

The field intensity along the normal is then $R \cos \theta$, and the flux going through dS is: $d\psi = R \cos \theta dS$, *i.e.*,

$$d\psi = R \cos (N,R)dS.$$

$$\begin{aligned} \therefore \psi &= \text{total outward flux through the surface,} \\ &= \iint R \cos \theta dS, \\ &= \iint N dS, \end{aligned}$$

where N is the component of the field intensity normal to dS , *i.e.*, $N = R \cos \theta$.

This can also be expressed in rectangular coördinates by vector analysis, provided that dS represents not a surface dS , but a vector at right angles to dS of size dS . (See appendix for dot product.)

Let

$$R = X(x,y,z)i + Y(x,y,z)j + Z(x,y,z)k$$

and

$$dS = dS_x i + dS_y j + dS_z k.$$

Then,

$$\int \int R \cdot dS = \int \int (XdS_x + YdS_y + ZdS_z) = \int \int (Xdy-dz + Ydxdz + Zdxdy), \quad \left. \begin{array}{l} \text{where obviously } dS_x = dydz, \\ dS_y = dxdz, \text{ etc.} \end{array} \right\}$$

Another way of expressing the surface integral of a distributed vector field is:

$$\int \int (Xl + Ym + Zn)dS.$$

In these equations X, Y and Z are the components of the vector along the three axes l, m , and n , the direction cosines of the normal to the surface.

Thus: $l = \cos(N, x),$

and, $m = \cos(N, y),$
 $n = \cos(N, z).$

$$\therefore ldS = dydz,$$

and, $mdS = dzdx,$
 $ndS = dxdy.$

$$\therefore \int \int (XdS_x + YdS_y + ZdS_z) = \int \int (Xl + Ym + Zn)dS.$$

Gauss's Theorem.—According to GAUSS'S theorem the total normal outward flux from a closed surface containing a charge Q is $= 4\pi Q$.

Let N be the component of the field intensity R normal to an elemental surface of the bag dS .

The theorem can be expressed mathematically by:

$$\int \int NdS = 4\pi Q.$$

Let $d\omega$, Fig. 64, be the solid angle at A corresponding to dS or dS_1 , which is perpendicular to R

$$\therefore \frac{dS_1}{4\pi r^2} = \frac{d\omega}{4\pi},$$

or, $dS_1 = r^2 d\omega.$

$$\int \int NdS = \int \int R \cos \theta dS = \int \int R dS_1 = \int \int R r^2 d\omega.$$

But COULOMB'S law gives:

$$F = \frac{QQ_1}{r^2}$$

or since by definition

$$F = R,$$

when

$$Q_1 = \text{unity.}$$

Thus

$$R = \frac{Q}{r^2} \tag{1}$$

$$\therefore \iint Rr^2d\omega = \iint Qd\omega,$$

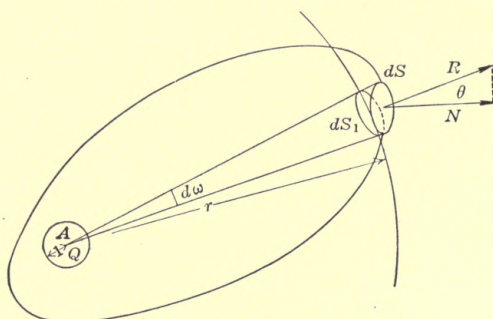

FIG. 64.

the integral to be taken around the entire surface, that is over the complete solid angle, which is 4π ,

$$\therefore \iint Qd\omega = 4\pi Q.$$

Thus,

$$\iint NdS = 4\pi Q,$$

or if there are many charges in the envelope,

$$\iint NdS = 4\pi \Sigma Q.$$

It is seen that the total flux radiating from a point charge Q or a magnet pole m is $\varphi = 4\pi Q$ and $\varphi = 4\pi m$ respectively.

It will be shown that while the conception of lines or tubes of force is very much the same, both serve to map out a field; by convention a tube includes 4π lines.

From (1) it is seen, that the intensity at a point distant r from a point charge Q is $\frac{Q}{r^2}$.

By a similar reasoning, it is readily seen that in magnetic problems,

$$\varphi = \text{magnetic flux} = 4\pi m;$$

and,

$$H = \frac{m}{r^2},$$

where m is the strength of the pole causing the field, and H is the intensity of the magnetic field.

But, to return to GAUSS'S theorem, it is readily seen that the shape of the bag is immaterial. Assume so, for instance, that the shape is that shown in Fig. 65.

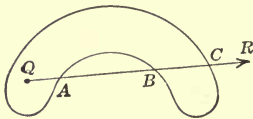

FIG. 65.

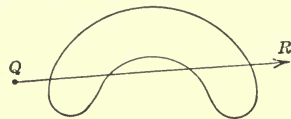

FIG. 66.

The vector R cuts the surface three times. The outward normal flux is positive at A , negative at B , and again positive at C . Thus the net result is one positive outward flux (Fig. 65). Were the charge outside of the envelope, then the flux cuts the bag two, four, six or an even number of times, so that the total outward flux is cancelled by an equal total inward flux (Fig. 66).

The net result then is, that

$$\int \int N dS = 0,$$

when the bag does not contain a charge.

Potential.—The electric potential is similar to the potential energy of matter; it is a space function.

The electric potential at a point is defined as the work done in bringing a unit positive charge from a place of zero field to the point under consideration.

The magnetic potential is defined in a similar way, substituting unit pole for unit charge.

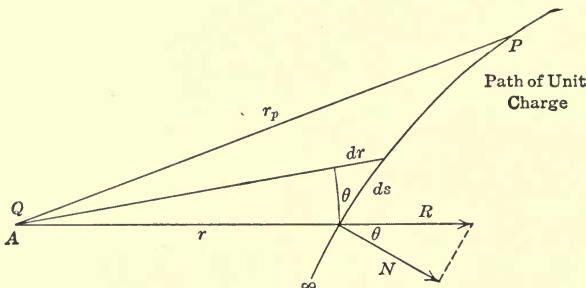

FIG. 67.

Referring to Fig. 67 R is the intensity at a point of the path of the unit charge in its journey from infinity, where the field is zero, to the point P , where the potential is to be determined, then

$$V = - \int R \cos \theta ds,$$

the minus sign being adopted by convention; but

$$dr = ds \cos \theta, \therefore ds = \frac{dr}{\cos \theta},$$

and,

$$V = - \int_{r=\infty}^{r=r_p} R dr = - \int_{\infty}^{r_p} \frac{Q}{r^2} dr = Q \left[\frac{1}{r} \right]_{\infty}^{r_p} = \frac{Q}{r_p}.$$

In general, the potential at a point due to several point charges is:

$$V = \sum \frac{Q}{r}, \text{ or } V = \sum \frac{m}{r}.$$

It is interesting to note that the potential is not dependent upon the path chosen in the journey; it depends only upon the point charge at *A* and the distance between *P* and *A*. It is strictly a space function.

The potential is the same on any surface the elements of which have the same distance from the point charge.

Thus the potential of the surface of a sphere having a point charge in its center, and influenced by no other charge, is:

$$V = \frac{Q}{r},$$

where *r* is the radius.

Since by definition the capacity is $C = \frac{Q}{V}$, we note that the capacity of an isolated sphere is $C = r$.

The capacity in the electrostatic system of units is in centimeters. A sphere of 10 cm. radius is said to have a capacity of 10 cm.

It will be shown later that to convert the capacity to farads involves a division by $\frac{V^2}{10^9} = \frac{(3 \times 10^{10})^2}{10^9} = 9 \times 10^{11}$. Thus in this case the capacity of the particular sphere would be $C = \frac{10}{9 \times 10^{11}}$ farads.

Line Integral.—The intensity *R* of the electric field has not only a definite numerical value, but also a definite direction.

Let the components of *R* along any three rectangular coördinates be, *X*, *Y* and *Z*, and let the components of the distance *ds* on the respective axes be *dx*, *dy* and *dz*. Then, since the poten-

tial is the same, no matter what path we may take, by travelling along the axes, we get:

$$V = - \int_{\infty}^{x,y,z} Xdx + Ydy + Zdz.$$

This integral is called the line integral of the distributed vector along the path.

Using vector analysis (see appendix) we get:

$$V = - \int R \cdot ds, \text{ the integral of the dot product,}$$

where

$$R = iX + jY + kZ,$$

and

$$ds = idx + jdy + kdz,$$

$$\therefore R \cdot ds = Xdx + Ydy + Zdz.$$

Differentiating, we get:

$$dV = - (Xdx + Ydy + Zdz) \quad (1)$$

Recollecting that if V is a function of the space coördinates x , y and z only,

$$dV = \frac{\partial V}{\partial x} dx + \frac{\partial V}{\partial y} dy + \frac{\partial V}{\partial z} dz.$$

It is evident, since it has been shown that the potential is a function depending only upon the space coördinates, that

$$\left. \begin{array}{l} \frac{\partial V}{\partial x} = - X \\ \frac{\partial V}{\partial y} = - Y \\ \frac{\partial V}{\partial z} = - Z \\ \frac{\partial V}{\partial n} = - R \end{array} \right\} \quad (2)$$

where $\frac{\partial}{\partial n}$ means differentiation along the lines of force, $-\frac{\partial V}{\partial n}$ is usually denoted by G , the potential gradient.

Equation (1) must be a complete differential, the criterion of which is that,

$$\begin{aligned} \frac{\partial Y}{\partial x} - \frac{\partial X}{\partial y} &= 0, \\ \frac{\partial Z}{\partial y} - \frac{\partial Y}{\partial z} &= 0, \end{aligned}$$

and
$$\frac{\partial X}{\partial z} - \frac{\partial Z}{\partial x} = 0;$$

$$\frac{\partial Y}{\partial x} = - \frac{\partial^2 V}{\partial y \partial x}$$

and
$$\frac{\partial X}{\partial y} = - \frac{\partial^2 V}{\partial x \partial y},$$

Thus,
$$\frac{\partial Y}{\partial x} - \frac{\partial X}{\partial y} = 0,$$
 which was to be proven

Gauss's Theorem in Term of Potential Gradient.—From equation (2) it is evident that GAUSS's theorem can be expressed in yet another form.

Since $R = - \frac{\partial V}{\partial n}$, it is evident that

$$\iint - \frac{\partial V}{\partial n} dS \text{ is the total outward flux.}$$

Thus,

$$\iint - \frac{\partial V}{\partial n} dS = 4\pi Q,$$

if the envelope contains a charge; and

$$\iint - \frac{\partial V}{\partial n} dS = 0, \text{ if the envelope contains no charge.}$$

In both cases, $\frac{\partial}{\partial n}$ means differentiating along the normal to surface, dS .

On account of the similarity between the electric and magnetic definitions, we obtain, by reasoning identically with that given above, for the magnetic potential,

$$V = - \int_{\infty}^{x,y,z} H \cos \theta ds = - \int_{\infty}^{x,y,z} (Ldx + Mdy + Ndz),$$

where

$$L = - \frac{\partial V}{\partial x}, \quad M = - \frac{\partial V}{\partial y}, \quad N = - \frac{\partial V}{\partial z}, \quad \text{and} \quad H = - \frac{\partial V}{\partial n};$$

and,

$V = \Sigma \frac{m}{r}$; $\iint \frac{\partial V}{\partial n} dS = - 4\pi \Sigma m$, if the envelope contains magnetic particles; and $\iint \frac{\partial V}{\partial n} dS = 0$; if the envelope does not contain magnetic particles.

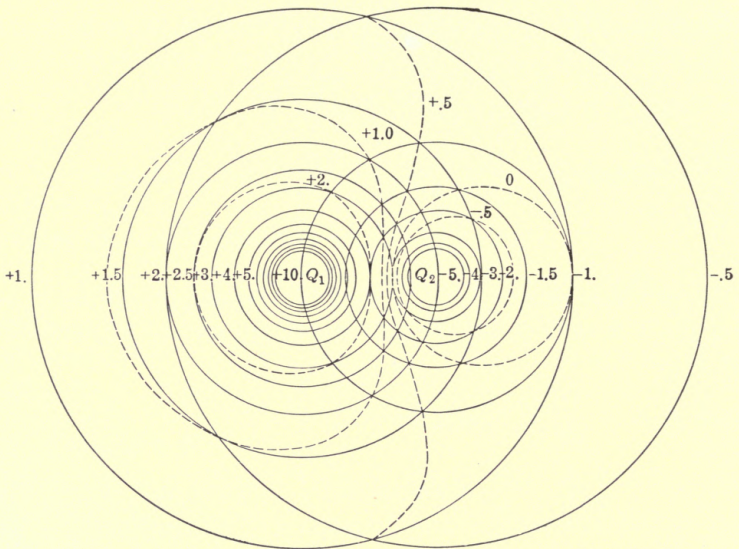

Equipotential Surfaces shown in Dotted Lines Around Two Point Charges Separated 5 cm.; $Q_1 = +10$; $Q_2 = -5$.

FIG. 68.

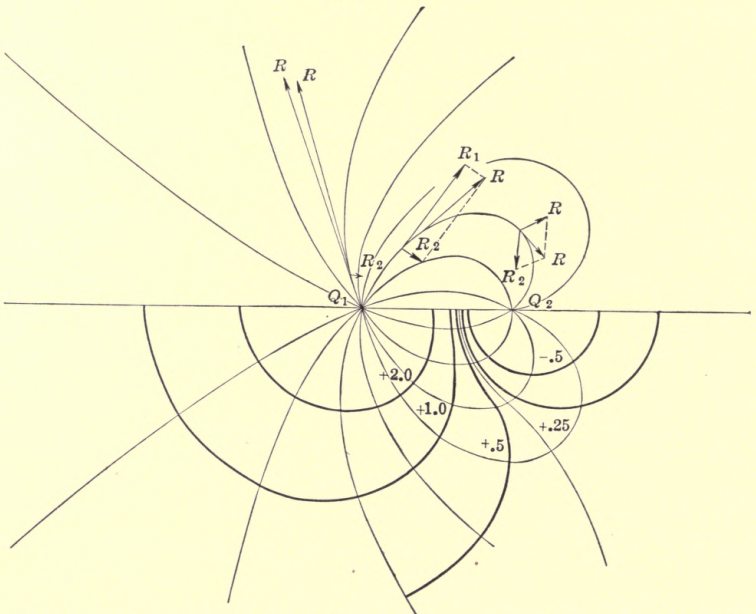

Lines of Force shown in Fine Lines and Equipotential Surfaces shown in Heavy Lines Around Two Point Charges Separated 5 cm.; $Q_1 = +10$, $Q_2 = -5$

FIG. 69.

In these equations, H is the intensity of the magnetic field, L , M and N are the components of the intensity, H , along the three axes.

Application of the Formula, $V = \Sigma \frac{V}{r}$.—In Fig. 68 is shown the equipotential surfaces between two point charges, $Q_1 = +10$ and $Q_2 = -5$, separated 5 cm.

The potential at any point, P , is obviously:

$$V_p = \frac{Q_1}{r_1} + \frac{Q_2}{r_2}.$$

The lines of force can not well be shown in a plane, but a fair idea of their shape can be gained from Fig. 69.

The direction of each line of force is obtained by combining R_1 , the intensity at a point due to Q_1 , and R_2 , the intensity due to Q_2 .

CHAPTER XIII

METHOD OF IMAGES, APPLIED TO THE PROBLEM OF POINT CHARGES +10 AND -5, SEPARATED 5 CM

In plotting the equipotential surfaces of the problem given above, it is readily seen and proven that the surface of zero potential, Fig. 70, is a sphere, and that the following relations obtain:

- (1) $a = \frac{Q_2^2}{Q_1^2 - Q_2^2} D;$
- (2) $\rho = -\frac{Q_1 Q_2}{Q_1^2 - Q_2^2} D;$
- (3) $\therefore \frac{\rho}{a} = -\frac{Q_1}{Q_2};$
- (4) $(D + a)a = \rho^2.$

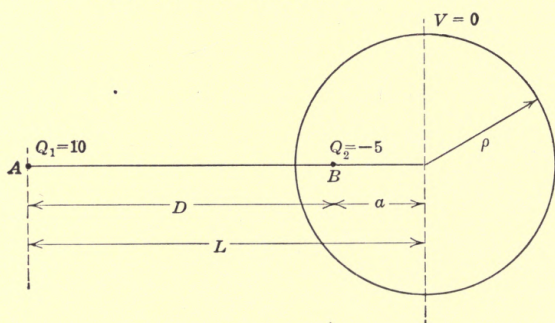

FIG. 70.

Substituting, we get $a = \frac{25}{75} \times 5 = 1.67$ cm. and $\rho = -\frac{50}{75} \times 5 = 3.33$ cm.

It is evident that the field distribution will not be affected if a grounded metallic sphere of radius, ρ , at a distance $(D + a)$ from the positive charge is surrounding the negative point charge at B.

And it is also evident that the potential will be the same ($= 0$), if the charge at B is removed altogether.

It is thus evident, that, reversing the line of argument, the potential distribution in a system involving a point charge at A and a grounded sphere of radius ρ with center at a distance L from the point charge, can be determined without the laborious determination of the distribution of the induced charge on the sphere, simply by using two point charges at A and B .

The location of B and the charge which must be assumed at the non-existing point B can be determined from the following relations which are easily proven:

$$L\rho(L - D) = \rho^2, \text{ or } D = L - \frac{\rho^2}{L},$$

and

$$Q_2 = - Q_1 \frac{\rho}{L}.$$

Potential Distribution between a Point Charge and a Metallic Sphere.—While it is evident then that the field can be determined without much labor in the case of a grounded sphere, the problem becomes quite involved if the sphere is insulated and kept at a certain potential, V , which is not zero.

To calculate the potential distribution in that case, it is necessary to study the distribution of the surface charge.

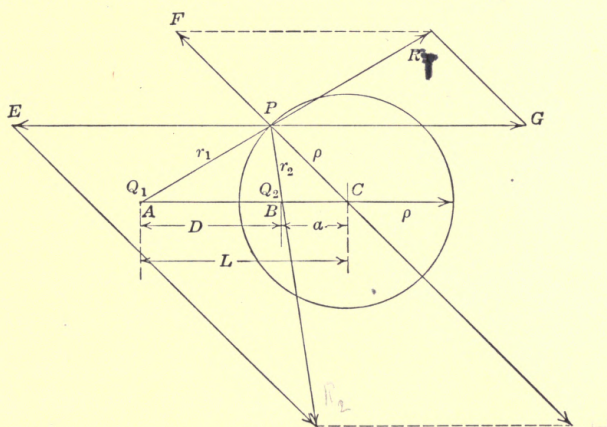

FIG. 71.

Consider first the case of the grounded sphere. The intensity of the field at a point is the resultant of the intensities due to the charges at A and B , the so-called inverse points.

It must be expected that the direction of the resultant field is perpendicular to the surface at all points, thus we can draw the

diagram in Fig. 71. Remembering that R , the intensity is the vectorial sum of

$$\frac{Q_1}{r_1^2} \text{ and } \frac{Q_2}{r_2^2}, \text{ or of } R_1 \text{ and } R_2.$$

The intensities R_1 and R_2 are resolved along the radius CP and along a line parallel to AB . It is seen that PE and PG are equal, and cancel each other, so that the resultant intensity is in line of CP and is $PF + PH$, algebraically.

Let the radius of the sphere in Fig. 71 be ρ . By similar triangles,

$$\frac{PF}{R_1} = \frac{PC}{PA}, \therefore PF = R_1 \cdot \frac{PC}{PA} = R_1 \cdot \frac{\rho}{r_1};$$

and
$$\frac{PH}{R_2} = \frac{PC}{PB}, \therefore PH = R_2 \cdot \frac{PC}{PB} = R_2 \cdot \frac{\rho}{r_2}$$

$$\therefore R = PF + PH = \rho \left(\frac{R_1}{r_1} + \frac{R_2}{r_2} \right).$$

But

$$R_1 = \frac{4\pi Q_1}{4\pi r_1^2} = \frac{Q_1}{r_1^2},$$

and

$$R_2 = \frac{Q_2}{r_2^2}.$$

$$\therefore R = \rho \left(\frac{Q_1}{r_1^3} + \frac{Q_2}{r_2^3} \right).$$

And it has been shown that $Q_2 = -Q_1 \frac{\rho}{L}$,

$$\therefore R = \rho Q_1 \left(\frac{1}{r_1^3} - \frac{\rho}{L r_2^3} \right).$$

Since $La = \rho^2$, from the figure, it is seen that,

$$\frac{r_1}{r_2} = \frac{L}{\rho}, \therefore r_2 = \frac{\rho}{L} r_1.$$

$$\therefore R = \rho \frac{Q_1}{r_1^3} \left(1 - \frac{\rho L^3}{L \rho^3} \right) = \frac{Q_1}{\rho r_1^3} (\rho^2 - L^2) \quad (1)$$

By Coulomb's theorem, $4\pi\sigma = R$, where σ is the surface density of charge, or charge per square centimeter,

$$\therefore \sigma = \frac{Q_1}{4\pi\rho r_1^3} (\rho^2 - L^2) \quad (2)$$

When the radius is very large, the surface of the sphere approaches a plane, Fig. 72, and a approaches ρ . Thus, if d , in Fig. 72, is the distance of the point charge from the plane of zero potential, we have:

$$L = \rho + d,$$

which, substituted in (1), gives:

$$R = \frac{Q_1}{\rho r_1^3} (\rho^2 - (\rho + d)^2) = \frac{Q_1}{\rho r_1^3} (-2\rho d - d^2),$$

or, since d^2 is small compared with $2\rho d$,

$$R = -\frac{2Q_1 d}{r_1^3};$$

and the surface density of charge is:

$$\sigma = -\frac{Q_1 d}{2\pi r_1^3}.$$

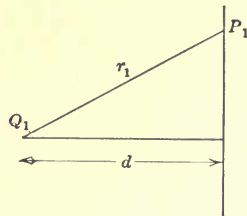

FIG. 72.

The surface density of charge decreases inversely as the cube of the distance from the point.

Assume now that the sphere is insulated and without charge, it will then have some potential not zero.

It was shown, that, when the sphere is at zero potential, it acts as if it had a charge $Q_2 = -Q_1 \frac{\rho}{L}$ at the inverse point B of point A . In order that its charge shall be zero, we have to apply mathematically, somewhere in the sphere, a charge $= -Q_2 = +Q_1 \frac{\rho}{L}$. Then the total charge obviously is zero.

Since the resultant potential of the external charge Q_1 and the internal charge $-Q_1 \frac{\rho}{L}$ gives zero potential of the spherical surface, in order to maintain a uniform potential V all over the sphere, the assumed charge must be applied in the center of the sphere.

Thus we deal with three charges, which combined cause the external field.

First.—The field due to the external point charge Q_1 .

Second.—The field due to the charge Q_2 at the inverse point.

Third.—The field due to the charge $-Q_2$ in the center of the sphere.

The charge $-Q_2$ gives a uniform surface density of

$$\sigma_1 = \frac{Q_2}{4\pi\rho^2} = + \frac{Q_1}{4\pi\rho L}$$

The combined effect of Q_1 at A and Q_2 at B has been shown to give a surface density of

$$\sigma_2 = \frac{Q_1}{4\pi r_1^3} \cdot \frac{\rho^2 - L^2}{\rho}$$

Thus the actual surface density is:

$$\sigma = \sigma_1 + \sigma_2 = \frac{Q_1}{4\pi\rho} \left(\frac{l}{L} + \frac{\rho^2 - L^2}{r_1^3} \right) \quad (3)$$

Equation (3) then gives the distribution of the surface charge on an insulated sphere without any independent charge. The equation must, and does show, that σ is positive on one side and negative on the other side, in order that the total charge be zero.

The potential of the sphere is obviously,

$$\frac{\text{charge}}{\text{radius}} = \frac{Q_1\rho}{\rho L} = \frac{Q_1}{L}$$

This is of interest, in that it shows that the potential of a sphere due to a point charge Q_1 situated L cm. from the center is $\frac{Q_1}{L}$.

This can be proven in a more general way as follows:

Assume that a non-conducting sphere be placed in an electric field caused by a number of point charges, a, b, c , etc. Let the potential of a small element of the sphere be V . The value of V changes from point to point of the surface of the sphere.

The average value of the potential V is:

$$V_m = \int \int \frac{V dS}{4\pi r^2}$$

where dS is an element of the surface.

Referring to Fig. 73:

$$dS = r \sin \theta d\phi r d\theta$$

$$\therefore V_m = \frac{1}{4\pi} \int \int V \sin \theta d\phi d\theta$$

and the average potential gradient along the radius is:

$$\frac{\partial V_m}{\partial r} = \frac{1}{4\pi} \int \int \frac{\partial V}{\partial r} \sin \theta d\phi d\theta = \frac{1}{4\pi r^2} \int \int \frac{\partial V}{\partial r} dS.$$

Since $\frac{\partial V}{\partial r}$ is the intensity as well as the gradient it follows that

$\frac{\partial V}{\partial r} dS$ is the flux diverging from the sphere. This is zero as we have assumed that no charge exists in the sphere.

Thus $\frac{\partial V_m}{\partial r} = 0$ and V_m is a constant for all values of r .

We conclude then that the average potential of a sphere is the same as the potential at the center.

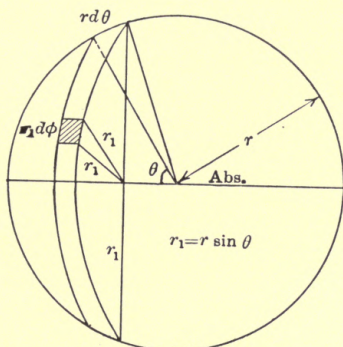

FIG. 73.

Suppose now that the insulated sphere had a charge Q_0 .

In order that the surface of the sphere shall be an equipotential surface, this charge also should be considered as placed in the center, and its surface density should be added to those given above.

$$\therefore \sigma = \sigma_1 + \sigma_2 + \frac{Q_0}{4\pi\rho^2} = \frac{Q_0}{4\pi\rho^2} + \frac{Q_1}{4\pi\rho} \left[\frac{1}{L} + \frac{\rho^2 - L^2}{r_1^3} \right].$$

The potential of the sphere will obviously be the sum of the potentials due to its own charge Q_0 and due to the point charge Q_1 .

$$\therefore V = \frac{Q_0}{\rho} + \frac{Q_1}{L},$$

or,

$$Q_0 = \rho \left(V - \frac{Q_1}{L} \right).$$

Usually V is known rather than Q_0 .

$$\therefore \sigma = \frac{1}{4\pi\rho} \left[V - \frac{Q_1}{L} \right] + \frac{Q_1}{4\pi\rho} \left[\frac{1}{L} - \frac{L^2 - \rho^2}{r_1^3} \right] = \frac{1}{4\pi\rho} \left[V - Q_1 \frac{L^2 - \rho^2}{r_1^3} \right].$$

It is of interest to find the attractive or repulsive force between the point charge at A and the sphere.

The force is, by COULOMB'S law, proportional to the product of charges and inversely proportional to the square of the distance.

The following conditions therefore exist:

First.—A charge $+ Q_1$ at A. Fig. 74.

Second.—A charge $- Q_1 \frac{\rho}{L}$ at B.

Third.—A charge $+ Q_1 \frac{\rho}{L} + Q_0$ at C.

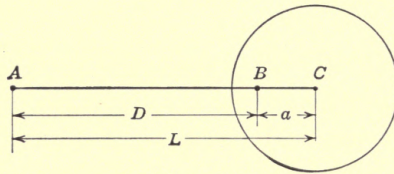

FIG. 74.

Thus the force between the sphere and the point charge is:

$$F = \frac{Q_1 \left(- Q_1 \frac{\rho}{L} \right)}{D^2} + \frac{Q_1 \left[Q_1 \left(\frac{\rho}{L} \right) + Q_0 \right]}{L^2}.$$

But it has been shown that $D = \frac{L^2 - \rho^2}{L}$,

$$F = \frac{- Q_1^2 L^2}{(L^2 - \rho^2)^2} \cdot \frac{\rho}{L} + \frac{Q_1^2 \rho}{L^3} + \frac{Q_0 Q_1}{L^2},$$

which, by transformations, becomes:

$$F = \frac{Q_0 Q_1}{L^2} - Q_1^2 \frac{\rho^3 (2L^2 - \rho^2)}{L^3 (L^2 - \rho^2)^2}.$$

Example.— $Q_1 = 1$, $Q_0 = 10$.

$L =$ variable.

$\rho = 10$.

For $L = 100$,

$$F = \frac{10}{10^4} - \frac{1000}{10^6} \frac{20,000 - 100}{(10,000 - 100)^2} = \sim \frac{1}{1000} \text{ dyne repulsion.}$$

For $L = 11$,

$$F = \frac{10}{121} - \frac{1000 (242 - 100)}{1330 (121 - 100)^2} = - 0.158 \text{ dyne attraction.}$$

It is thus seen that a lightly charged particle may be repelled, if far away from a charge of the same sign, and may be attracted when near. If, however, the charges are of opposite signs, the charges attract always.

Problem.—Construct the equipotential surfaces between an insulated charged sphere and a point charge, when

$$\begin{aligned} \rho &= 10 \text{ cm.}, \\ L &= 20 \text{ cm.}, \\ Q_1 &= 1, \end{aligned}$$

and

$$V = \frac{21}{20}.$$

Potential Distribution between Two Spheres.—Let sphere A in Fig. 75 have a pot. V and a radius R ; and sphere B have a pot. V_1 and a radius R_1 .

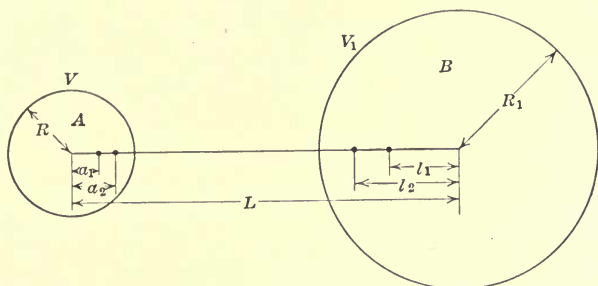

FIG. 75.

Calculate first the charges at A and B and the location of these charges, when A is at potential V and B is at zero potential. Then reverse the operation, and calculate the charges at A and B and the location of these charges, when B is at a potential V_1 and A is at zero potential. Then add the charges and potentials respectively, and the desired solution is obviously obtained.

(1) Calculation of the charges on A and B when the potential of A is V and that of B is zero:

The first approximation is obtained when the potential of A alone is considered. We have then, since in general $Q = VR$, a charge in the center of A of value $Q_0 = VR$, and we may, for completeness, say that its distance a_0 from the center is zero.

This charge affects B by giving B a potential, which is $\frac{VR}{L}$.

Since, however, the potential of B must be zero, it is necessary to supply B with a charge which gives a potential $-\frac{VR}{L}$. This charge, which may be called Q'_1 , has previously been shown to be $Q'_1 = -VR\left(\frac{R_1}{L}\right)$, shall not be placed in the center of

the sphere, but at a distance b_1 , which is obtained by the relation previously proven:

$$b_1 = \frac{(\text{radius})^2}{\text{distance from charge to center of sphere}}$$

$$\therefore b_1 = \frac{R_1^2}{L}$$

But the charge Q'_1 or $-\frac{VRR_1}{L}$ at b_1 affects the potential of A , so that its potential is no longer V , but

$$V + \left[\left(\frac{-VRR_1}{L} \right) \div (\text{distance from charge } Q'_1 \text{ to center of } A) \right]$$

$$= V - \frac{VRR_1}{L(L - b_1)}$$

To bring the potential of A back to V , A must be supplied with a charge, which is:

$$Q_1 = + \frac{VRR_1}{L(L - b_1)} R = \frac{VR^2R_1}{L(L - b_1)}$$

As far as the external action of the charge is concerned, it is located at a_1 , where as before

$$a_1 = \frac{R^2}{L - b_1}$$

This charge at a_1 affects sphere B and induces a potential which is

$$\frac{VR^2R_1}{L(L - b_1)(L - a_1)}$$

In order to bring the potential back to zero, a charge Q'_2 has to be added to B , which gives a potential of $\frac{-VR^2R_1}{L(L - b_1)(L - a_1)}$, and this charge, as far as external influences are concerned, is located at a point b_2 , where

$$b_2 = \frac{R_1^2}{(L - a_1)}$$

Continuing the process, the necessary additional charge on A to balance the effect of Q'_2 at b_2 is found to be:

$$Q_2 = - Q'_2 \frac{R}{(L - b_2)} = \frac{R}{L(L - b_1)(L - a_1)(L - b_2)} + \frac{VR^3R_1^2}{L(L - b_1)(L - a_1)(L - b_2)}$$

and

$$a_2 = \frac{R^2}{(L - b_2)}$$

Again,

$$Q'_3 = \frac{-VR^3R_1^3}{L(L - b_1)(L - a_1)(L - b_2)(L - a_2)}$$

and

$$b_3 = \frac{R_1^2}{(L - a_2)}$$

The total charge on A is $Q_A = Q_0 + Q_1 + Q_2 + \dots$;

The total charge on B is $Q_B = Q'_1 + Q'_2 + Q'_3 + \dots$.

But, it must be remembered that in order to find the intensity of the field at any point, the position of the charges has to be considered.

(2) By an identical method, a new set of charges are obtained, when A is kept at zero potential and B at its potential V .

The total charges on A and B are the sum of all the charges so calculated.

Assuming, for instance, that the potentials of A and B are both positive.

The first set of calculations will then give a number of positive charges in A , all of which, except the first, located at points, not its center, the charges in B will all be negative, and all be located at points not its center.

The second set of calculations (not shown above) will result in a series of negative charges in A , all of which are located at points not its center, and a set of positive charges in the sphere B , the first of which is at its center. Thus the total charge in either A or B is a sum of a series of positive and negative charges.

Simple Case.—For two similar spheres, one at zero potential and the other at a potential, V , we have:

On the sphere of pot. V	On the sphere of pot. zero
$Q_0 = VR$	$Q'_1 = -\frac{VR^2}{L}$
$a_0 = 0$	$b_1 = \frac{R^2}{L}$
$Q_1 = \frac{VR^3}{L(L - b_1)}$	$Q'_2 = -\frac{VR^4}{L(L - b_1)(L - a_1)}$
$a_1 = \frac{R^2}{(L - b_1)}$	$b_2 = \frac{R^2}{(L - a_1)}$
$Q_2 = \frac{VR^5}{L(L - b_1)(L - a_1)(L - b_2)}$	$Q'_3 = \frac{VR^6}{L(L - b_1)(L - a_1)(L - b_2)(L - a_2)}$
$a_2 = \frac{R^2}{(L - b_2)}$	$b'_3 = \frac{R^2}{(L - a_2)}$
.....

The total charge on the sphere of potential V is:

$$Q_A = Q_0 + Q_1 + Q_2 + \dots ;$$

and that of the sphere of zero potential is:

$$Q_B = Q'_1 + Q'_2 + Q'_3 + \dots$$

To study the sphere gap, the following problem has been solved to show more particularly, that, while the difference in potential between two gaps may be the same, one gap may break down with considerably lower potential difference than the other.

Air at atmospheric pressure appears to sustain, as a maximum, a density of about 100 lines per sq. cm., or a potential gradient of 100, electrostatic units or in practical units 30,000 volts per cm. If, therefore, the potential to ground is high, the air may well break down around the spheres, even though the potential difference between the spheres may be comparatively low.

When the air breaks down, corona appears. Then the effective dimensions of the spheres are increased and the gap length correspondingly lowered.

The following three cases are calculated, and the results are tabulated below.

Diameter of the spheres, 25 cm.

Distance between surfaces, 14 cm.

Potential difference 1000 electro static units or 300,000 volts.

In the first case, sphere A has a potential of 1000 and B is at zero potential, in the second case the spheres are at potentials +500 and -500 respectively, and in the third case they are at potentials +1500 and +500 respectively. In the example the potential gradient G is calculated at the surface of the sphere of highest potential on the center line between the spheres although it may, of course, be greater at some other points. In general $G = - \sum \frac{Q}{(\text{dist.})^2}$. The gradients due to the two spheres should obviously be added if the charges are of opposite potential. Since the intensity of the field is in the same direction at the point considered.

Summary of the first case:

For sphere A,

$a_0 = 0$	$Q_0 = 12,500$
$a_1 = 4.46$	$Q_1 = 1,430$
$a_2 = 4.53$	$Q_2 = 186$
$a_3 = 4.53$	$Q_3 = 24.4$

For sphere B,

$b_0 = 0$	$Q'_0 = 0$
$b_1 = 4$	$Q'_1 = -4,000$
$b_2 = 4.5$	$Q'_2 = -516$
$b_3 = 4.53$	$Q'_3 = -67.3$
$b_4 = 4.53$	$Q'_4 = -9$

In general $G = \frac{Q}{d^2}$,

$$\therefore G = -\sum \frac{Q}{d^2} = -114.6, \text{ or, } -34,500 \text{ volts per cm.}$$

Thus the sphere probably begins to glow.

Summary of the second case:

$a_0 = b_0 = 0$	$Q_0 = Q'_0 = 6,250$
$a_1 = b_1 = 4.01$	$Q_1 = Q'_1 = 2,000$
$a_2 = b_2 = 4.45$	$Q_2 = Q'_2 = 714$
$a_3 = b_3 = 4.51$	$Q_3 = Q'_3 = 258$
$a_4 = b_4 = 4.53$	$Q_4 = Q'_4 = 93.5$
$a_5 = b_5 = 4.54$	$Q_5 = Q'_5 = 34.2$

$G = -100.2$ or about $-30,000$ volts per cm. The spheres ought to be just about on the point of glowing.

Summary of third case:

$Q_0 = 18,750$	$Q'_0 = 6,250$
$Q_1 = -2,000$	$Q'_1 = -6,000$
$Q_2 = +2,140$	$Q'_2 = +714$
$Q_3 = -258$	$Q'_3 = -775$
$Q_4 = +280$	$Q'_4 = +93.5$
$Q_5 = -34.2$	$Q'_5 = -102.6$

The a 's and b 's are the same as above.

$$G = -128 \text{ or } -38,400 \text{ volts per cm.}$$

Thus the spheres glow undoubtedly, and if "ground" is under the spheres the potential gradient may be slightly higher below the line connecting the centers of the spheres.

CHAPTER XIV

APPLICATION OF THE POTENTIAL FORMULA $V = \Sigma \frac{m}{r}$ TO SOME MAGNETIC PROBLEMS

The magnetic potential at a point in a magnetic field is, as has already been stated, the work done in ergs in bringing a unit pole from infinity, or a point of no magnetic field, to the point under consideration.

By GAUSS'S theorem the outward normal flux from a pole of strength m is $4\pi m$. Thus the intensity of the magnetic field, H , at a distance, r , from the pole is $\frac{4\pi m}{4\pi r^2}$;

or,
$$H = \frac{m}{r^2};$$

and,
$$V = - \int_{\infty}^r \frac{m}{r^2} dr = \frac{m}{r};$$

or in general, $V = \Sigma \frac{m}{r}$.

Obviously, a magnetic pole can not exist alone; there is always a north pole and a south pole in every magnet. Thus to get the potential at a point, at least two poles of opposite signs must be considered.

The potential of a small magnet at distance large compared with its dimension is:

$V = \frac{ml \cos \theta}{r^2}$, where θ is the angle the axis of the magnet makes

with the radius vector to the point.

This is readily seen, if the magnetism be assumed as concentrated at the poles of the magnet.

Referring to Fig. 76, the potential at P is:

$$V = \frac{m}{AP} + - \frac{m}{BP} = \frac{m}{\sqrt{\frac{l^2}{4} + r^2 + 2 \left(\frac{l}{2}\right) r \cos \theta}} - \frac{m}{\sqrt{\frac{l^2}{4} + r^2 - 2 \left(\frac{l}{2}\right) r \cos \theta}} \quad (1)$$

If r is large, compared with l then $V =$

$$\frac{m}{\sqrt{r^2 + lr \cos \theta}} - \frac{m}{\sqrt{r^2 - lr \cos \theta}}$$

The square root can be expanded by the binomial theorem. We have,

$$\begin{aligned} V &= \frac{m}{r} \left[\left(1 + \frac{l}{r} \cos \theta \right)^{-1/2} - \left(1 - \frac{l}{r} \cos \theta \right)^{-1/2} \right] \\ &= \frac{m}{r} \left[1 - \frac{1}{2} \frac{l}{r} \cos \theta + \dots - 1 - \frac{1}{2} \frac{l}{r} \cos \theta \dots \right] \\ &= - \frac{ml}{r^2} \cos \theta \text{ (approximately)} \end{aligned} \tag{2}$$

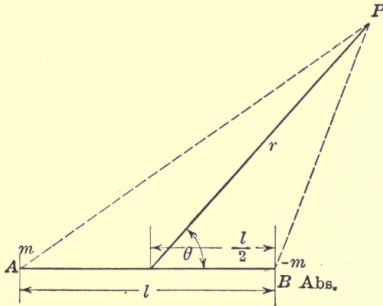

FIG. 76.

It is seen from (1) that the magnetic potential at P is m times the difference in $\frac{1}{r}$, as we go from one pole to another, where r is the distance from a pole to the point P . Let $l = ds$, then the rate of change of $\frac{1}{r}$ along ds , is:

$$\begin{aligned} \frac{\partial}{\partial s} \left(\frac{1}{r} \right), \text{ thus the total difference is } \frac{\partial}{\partial s} \left(\frac{1}{r} \right) ds, \\ \therefore V = m \frac{\partial}{\partial r} \left(\frac{1}{r} \right) ds. \end{aligned}$$

If $l', m',$ and n' are the direction cosines of the magnetic particle at (x, y, z) , we can then also write,

$$V = m \left[l' \frac{\partial}{\partial x} \left(\frac{1}{r} \right) + m' \frac{\partial}{\partial y} \left(\frac{1}{r} \right) + n' \frac{\partial}{\partial z} \left(\frac{1}{r} \right) \right] ds.$$

Magnetic Shell.—A thin piece magnetized at right angles to its surface is called a magnetic shell. It can thus be assumed as

made up of a large number of small magnets as shown in Fig. 77. Let the total pole strength in Fig. 78 be m and the area S , then the pole strength per unit area is $\frac{m}{S}$. Let the thickness of the shell be l , then the potential at P due to the shell is from equation (2).

$$V = \iint \frac{ml \cos \theta}{S_1 r^2} dS = \frac{ml}{S} \iint \frac{\cos \theta}{r^2} dS = \frac{ml \omega}{S},$$

where ω is the solid angle at P subtended by the surface of the shell.

(Recollect that the solid angle, $d\omega = \frac{dS}{r^2} \cos \theta$.)

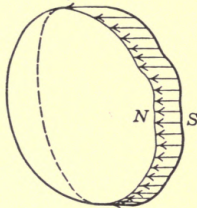

FIG. 77.

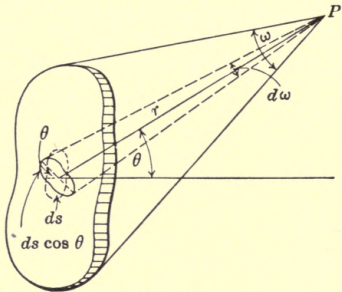

FIG. 78.

ml is called the magnetic moment, the strength of a magnetic shell or the moment per unit area is usually denoted by g ,

$$\therefore g = \frac{ml}{S}$$

and,

$$V = g\omega.$$

WEBER proved experimentally that a small circuit in a plane carrying current produces the same kind of a field as a magnet, and that the potential at a point depends upon the area A of the coil, the current I , and the distance to the point, by a relation:

$$V = \frac{KAI \cos \theta}{r^2},$$

from which the electromagnetic unit of current can be determined by making k unity.

$$\therefore \frac{AI \cos \theta}{r^2} = \frac{ml \cos \theta}{r^2},$$

thus, and $I = \frac{ml}{A} = g$, the strength of the magnetic shell surrounded by the circuit or coil.

Since we have proven that $V = g\omega$, we get the following simple relation between magnetic potential and current:

$V = I\omega$, where ω is the solid angle subtended at the point by the surface of the coil. It is evident then, that, as long as we do not tread the circuit, and as long as we return to the starting point, the work done in moving a pole in the field is zero.

To illustrate this, the potential at a point on the axis of a circular wire carrying I abs. amp. will be determined.

First let the point be at the center of the coil, Fig. 79, then $\omega = 2\pi$, and, $V = 2\pi I$.

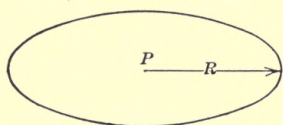

FIG. 79.

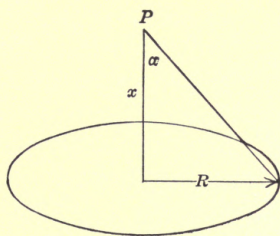

FIG. 80.

If the point is on the axis, but a distance x from the face of the coil as shown in Fig. 80, then the solid angle is:

$$\omega = 2\pi(1 - \cos \alpha) = 2\pi\left(1 - \frac{x}{\sqrt{R^2 + x^2}}\right),$$

and,

$$V = 2\pi I \left(1 - \frac{x}{\sqrt{R^2 + x^2}}\right).$$

The magnetic field intensity along the x -axis, which is the direction of the magnetic field, is:

$$H = -\frac{\partial V}{\partial x} = \frac{2\pi IR^2}{(R^2 + x^2)^{3/2}};$$

and the force in dynes on a pole of strength m is:

$$F = \frac{2\pi R^2 m}{(R^2 + x^2)^{3/2}};$$

for $x = 0$, that is if the point is in the plane of the coil and in its center,

$$H = \frac{2\pi I}{R}.$$

The work done in bringing unit pole once or several times through a loop carrying a current I will now be investigated.

Referring to Fig. 81, before the journey starts, the potential at P has been shown to be $I\omega$.

When the journey has covered 1 revolution, the solid angle has changed from 0 to 4π . Thus, after n revolutions of the unit pole the potential of it is:

$$I\omega + 4\pi In = I(\omega + 4\pi n).$$

It is evident then, that, when a magnetic-pole of strength m is moved around in a field, and returned to the starting point, work will be done every time the circuit is treaded. If it is treaded n times, the work is:

$$4\pi Inm.$$

The magnetic potential is thus a multi-valued function of the space coördinates.

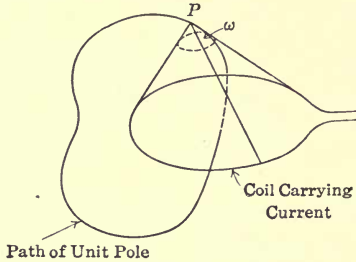

FIG. 81.

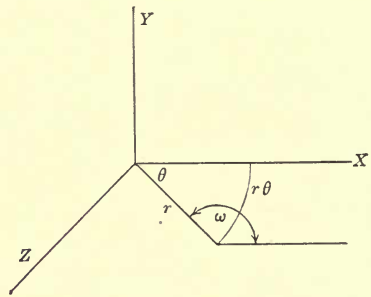

FIG. 82.

The intensity of the magnetic field at the point, $H = -\frac{\partial V}{\partial r}$ depends, however, only upon the term involving the solid angle ω , not upon the term involving $4\pi n$.

Consider now a straight infinitely long wire carrying current I .

Let the wire form the y -axis and let the point be in the xz -plane (Fig. 82). The cone subtended by the plane of the current (x - y plane with y -axis as one edge) which goes out to infinity and the point P has a solid angle, $2(\pi - \theta)$.

NOTE.—If the angle in the xz -plane had been π , the solid angle would have been 2π ; in this case the former is $(\pi - \theta)$, the latter is $2(\pi - \theta)$.

$$\therefore V = I(\omega + 4\pi n) = (2\pi - 2\theta + 4\pi n).$$

The direction of the lines of force which are circles around the y axis are along the arc, $rd\theta$, then

$$H = -\frac{dV}{rd\theta} = \frac{2I}{r},$$

an equation very often used in electrical engineering.

CHAPTER XV

DIVERGENCE OF A VECTOR, POISSONS AND LAPLACE EQUATION

It has been shown by GAUSS'S theorem that the total flux entering and leaving a closed surface in a vector field is zero, unless the (closed) surface contains some charge Q , in which case the outward flux equals $4\pi Q$.

This charge may be a single charge, or it may consist of a large number of small charges throughout the interior of the surface.

The divergence of a vector is the excess of outgoing flux over the incoming flux per unit volume of the space enclosed by the surface; it is the number of lines which diverge per unit volume.

If the excess of flux in a small volume dv is $d\psi$, then the divergence of the vector is $\frac{d\psi}{dv}$.

It is written $\text{div. } R$, $\text{div. } (X, Y, Z)$ or $\nabla \cdot R$ (read del dot R), where ∇ stands for $\frac{i\partial}{\partial x} + \frac{j\partial}{\partial y} + \frac{k\partial}{\partial z}$. ∇ is sometimes called LAME'S differential parameter.

It is evident, from what has been said above, that unless some charges are enclosed in the small volume, there can be no divergence. If there are as many units of positive charge as of negative charge in each small volume, there can also be no divergence, *i.e.*, $\text{div. } R = 0$. The divergence is positive, if there is an excess of positive

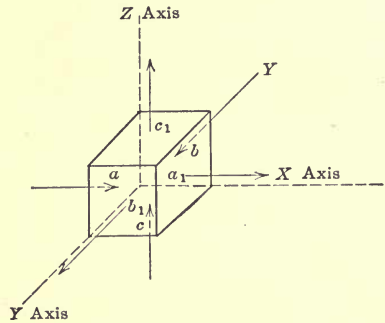

FIG. 83.

charge; it is negative (sometimes called convergence), if there is an excess of negative charge. The presence of divergences involves the presence of charges. In hydraulics the presence of divergence means either the presence of some source of fluid in the element or some change in density.

Consider a small volume represented by a cube, in Fig. 83 for the sake of simplicity. This cube is assumed to be a small part

of the total volume enclosed by the envelope that contains the charges.

Let X , Y and Z be the components of the field intensity R parallel to the coördinate axes and at the center of the surface a , b and c .

If R is a continuous function, which depends upon the space coördinates only, and if the edges of the cube are dx , dy , dz then the value of the z -component of the field intensity at $C_1 = Z_1 = Z + \frac{\partial Z}{\partial z} dz$.

Thus, the incoming flux at c is: $Z dx dy$, the outgoing flux at c_1 is $\left(Z + \frac{\partial Z}{\partial z} dz \right) dx dy$.

Consequently, the difference is

$$\left(\frac{\partial Z}{\partial z} dz \right) dx dy;$$

Similarly, for the other sides,

$$\left(\frac{\partial X}{\partial x} dx \right) dy dz;$$

and

$$\left(\frac{\partial Y}{\partial y} dy \right) dz dx.$$

The total diverging flux is thus:

$$d\psi = \left(\frac{\partial X}{\partial x} + \frac{\partial Y}{\partial y} + \frac{\partial Z}{\partial z} \right) dx dy dz = \nabla \cdot R dv.$$

Hence by definition

$$\text{div. } R = \nabla \cdot R \frac{dv}{dv} = \nabla \cdot R.$$

If ρ is the charge per unit volume or the volume density, then the outward normal flux is $4\pi\rho$.

$$\therefore \text{Div. } R = 4\pi\rho = \frac{\partial X}{\partial x} + \frac{\partial Y}{\partial y} + \frac{\partial Z}{\partial z}.$$

A vector field is said to be solenoidal, if there is no divergence. Such a field is, for instance, the electric field in free space or the field of force of gravitation in free space.

The *divergence theorem* connects the surface and volume integrals and states that the surface integral of the normal outward flux of a distributed vector is equal to the volume integral of the divergence taken throughout the volume. It is one of the forms of *Green's theorem*.

It is

$$\iint R \cos \theta dS = \iiint \left(\frac{\partial X}{\partial x} + \frac{\partial Y}{\partial y} + \frac{\partial Z}{\partial z} \right) dx dy dz.$$

Using the notation of vector analysis, we get:

$$\iint n \cdot R dS = \iiint R dv,$$

where n is the unit normal vector.

This theorem is subject to rigid mathematical proof, but can be understood without advanced mathematics, if the volume enclosed by the surface is assumed to be divided up into a large number of small volumes, each fitting tightly against the others.

As we add the normal outward fluxes of the different elemental volumes, all will cancel, except those on the very outside surface, since every wall separating two elements is integrated over twice with normals in opposite direction.

The outward normal flux is $\iint R \cos \theta ds$. Since the excess of outgoing flux over the incoming flux in the element of volume, $dx dy dz$, is:

$\left(\frac{\partial X}{\partial x} + \frac{\partial Y}{\partial y} + \frac{\partial Z}{\partial z} \right) dx dy dz$, it follows that the total outgoing flux is:

$$\iiint \left(\frac{\partial X}{\partial x} + \frac{\partial Y}{\partial y} + \frac{\partial Z}{\partial z} \right) dx dy dz, \text{ which is equal to } \iint R \cos \theta dS.$$

Poisson's equation is:

$$\left(\frac{\partial^2 V}{\partial x^2} + \frac{\partial^2 V}{\partial y^2} + \frac{\partial^2 V}{\partial z^2} \right) = -4\pi\rho.$$

This becomes: $\frac{\partial X}{\partial x} + \frac{\partial Y}{\partial y} + \frac{\partial Z}{\partial z} = +4\pi\rho,$

If X , Y and Z are gradients or intensities of a scalar point function V , so that

$$X = -\frac{\partial V}{\partial x}; Y = -\frac{\partial V}{\partial y}; Z = -\frac{\partial V}{\partial z}.$$

$$\therefore \frac{\partial X}{\partial x} = -\frac{\partial^2 V}{\partial x^2};$$

$$\frac{\partial Y}{\partial y} = -\frac{\partial^2 V}{\partial y^2};$$

$$\frac{\partial Z}{\partial z} = -\frac{\partial^2 V}{\partial z^2};$$

and

$$\frac{\partial^2 V}{\partial x^2} + \frac{\partial^2 V}{\partial y^2} + \frac{\partial^2 V}{\partial z^2} = -4\pi\rho,$$

where ρ is the density of electrification or charge per unit volume.

This equation then applies, when the region of the electrostatic field under consideration contains positive or negative charges, or sources and sinks as some writers call them.

Laplace's equation is:

$$\frac{\partial^2 V}{\partial x^2} + \frac{\partial^2 V}{\partial y^2} + \frac{\partial^2 V}{\partial z^2} = 0,$$

or, as it is often written,

$$\nabla^2 V = 0,$$

(Read del square $V =$ zero) and refers to a region in which there are no charges, or to a solenoidal field.

By means of LAPLACE'S equation it is possible to determine the potential at any point in the dielectric surrounding a charged body. If the body is unsymmetrical in every way the equation becomes very involved, but if, as is almost always the case in practice, there is some axis of symmetry and particularly if the body has circular symmetry then the potential distribution can usually be calculated fairly easily, especially if a table of LEGENDRE'S coefficients is available.

CHAPTER XVI

LEGENDRE'S FUNCTION

The potential at points outside of the bodies having circular symmetry, such as circular discs, circular rings, etc., can be determined very readily by means of a certain function, viz., LEGENDRE'S function, which has been worked out and is tabulated much in the same way as trigonometric functions. LAPLACE'S equation

$$\frac{\partial^2 V}{\partial x^2} + \frac{\partial^2 V}{\partial y^2} + \frac{\partial^2 V}{\partial z^2} = 0 \quad (1)$$

can be used as has been shown in exploring the space surrounding charged body.

With circular symmetry of the charged body it is obviously advantageous to express the equation in spherical coördinates (see Appendix heading Partial Differentiation). Thus,

$$\frac{r\partial^2 (rV)}{\partial r^2} + \frac{1}{\sin \theta} \frac{\partial}{\partial \theta} \left(\sin \theta \frac{\partial V}{\partial \theta} \right) + \frac{1}{\sin^2 \theta} \frac{\partial^2 V}{\partial \phi^2} = 0 \quad (2)$$

With z -axis as the axis of circular symmetry, the potential will be the same for all values of ϕ , as long as r and θ are constant, as is readily seen in Fig. 84.

Equation (2) becomes:

$$\frac{r\partial^2 (rV)}{\partial r^2} + \frac{1}{\sin \theta} \frac{\partial}{\partial \theta} \left(\sin \theta \frac{\partial V}{\partial \theta} \right) = 0 \quad (3)$$

This is then an equation of two independent variables, r and θ . The general method of solving such equation is to assume the solution to be:

$V = R'\theta'$,¹ where R' is a function of r only, and θ' is a function of θ only.

Substituting in (3),

$$r \frac{\partial^2}{\partial r^2} (rR'\theta') + \frac{1}{\sin \theta} \frac{\partial}{\partial \theta} \left(\sin \theta \frac{\partial}{\partial \theta} (R'\theta') \right) = 0 \quad (4)$$

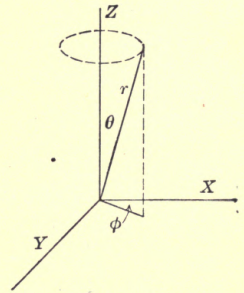

FIG. 84.

¹NOTE.—See Byerly's "Fourier's Series and Spherical Harmonics."

$$\text{or, } r\theta' \frac{\partial^2}{\partial r^2} (rR') = - \frac{R'}{\sin \theta} \frac{\partial}{\partial \theta} \sin \theta \frac{\partial \theta'}{\partial \theta},$$

$$\text{or, } \frac{r}{R'} \frac{\partial^2 (rR')}{\partial r^2} = - \frac{1}{\theta' \sin \theta} \frac{\partial}{\partial \theta} \left(\sin \theta \frac{\partial \theta'}{\partial \theta} \right) \quad (5)$$

The left-hand term is a function of r only, the right-hand term of θ only.

In order then that this shall hold for all values of r and θ , each term must not only be a constant, but must be the same constant.

Let this constant which is entirely arbitrary, be a^2 ,

$$\frac{r}{R'} \frac{\partial^2 (rR')}{\partial r^2} = a^2, \text{ or, } \frac{r\partial^2 (rR')}{\partial r^2} - a^2 R' = 0 \quad (6)$$

$$\text{and } \frac{1}{\sin \theta} \frac{\partial}{\partial \theta} \left(\frac{\sin \theta \cdot \partial \theta'}{\partial \theta} \right) + a^2 \theta' = 0 \quad (7)$$

Equation (6) becomes;

$$r^2 \frac{d^2 R'}{dr^2} + 2r \frac{dR'}{dr} - a^2 R' = 0 \quad (8)$$

$$\text{Since } \frac{d}{dr} (rR') = r \frac{dR'}{dr} + R',$$

$$\frac{d^2}{dr^2} (rR') = r \frac{d^2 R'}{dr^2} + \frac{dR'}{dr} + \frac{dR'}{dr} = r \frac{d^2 R'}{dr^2} + 2r \frac{dR'}{dr}$$

The solution of (8) is readily found, it is:

$$R' = Ar^m + Br^n.$$

$$\text{where } m = -\frac{1}{2} + \sqrt{a^2 + \frac{1}{4}}$$

$$\text{and } n = -\frac{1}{2} - \sqrt{a^2 + \frac{1}{4}},$$

$$\text{Thus: } n = -m - 1 \quad (9)$$

$$\therefore R' = Ar^m + \frac{B}{r^{m+1}} \quad (10)$$

It is evident then that r^m and $\frac{1}{r^{m+1}}$ are particular solutions of equation (6).

If we choose for a^2 a value which is:

$$a^2 = m(m+1),$$

then equation (9) is satisfied, since

$$\sqrt{a^2 + \frac{1}{4}} = \sqrt{m^2 + m + \frac{1}{4}} = m + \frac{1}{2}.$$

It has been shown that r^m is a particular solution of R' , thus using this solution at first, we get

$$V = r^m \theta^1.$$

Substituting this in equation (3) we get,

$$m(m + 1) \theta' + \frac{1}{\sin \theta} \frac{\partial}{\partial \theta} \left(\sin \theta \frac{\partial \theta'}{\partial \theta} \right) = 0 \quad (11)$$

since,
$$\frac{\partial (rV)}{\partial r} = \frac{\partial}{\partial r} (r^{m+1} \theta') = \theta' (m + 1) r^m,$$

$$\frac{\partial^2 (rV)}{\partial r^2} = \theta' m(m + 1) r^{m-1},$$

and,
$$\frac{\partial V}{\partial \theta} = \frac{\partial (r^m \theta')}{\partial \theta} = r^m \frac{\partial \theta'}{\partial \theta}.$$

Equation (11) can be solved for θ' .

We have,

$$\frac{\partial}{\partial \theta} \left(\sin \theta \frac{\partial \theta'}{\partial \theta} \right) = \sin \theta \frac{\partial^2 \theta'}{\partial \theta^2} \cos \theta \frac{\partial \theta'}{\partial \theta} \quad (12)$$

Let $x = \cos \theta$, there $\sin \theta = \sqrt{1 - x^2}$.

In equation (12), is to be determined $\frac{\partial \theta'}{\partial \theta}$ and $\frac{\partial^2 \theta'}{\partial \theta^2}$.

$$\frac{\partial \theta'}{\partial \theta} = \frac{\partial \theta'}{\partial x} \cdot \frac{\partial x}{\partial \theta} = - \frac{\partial \theta'}{\partial x} \sin \theta = - \frac{\partial \theta'}{\partial x} \sqrt{1 - x^2} \quad (13)$$

$$\begin{aligned} \frac{\partial^2 \theta'}{\partial \theta^2} &= \left(\frac{\partial}{\partial x} \frac{\partial \theta'}{\partial \theta} \right) \frac{\partial x}{\partial \theta} = \left[\frac{\partial}{\partial x} \left(- \frac{\partial \theta'}{\partial x} \sqrt{1 - x^2} \right) (- \sin \theta) \right] \\ &= \left(\frac{\partial^2 \theta'}{\partial x^2} \sqrt{1 - x^2} - \frac{x}{\sqrt{1 - x^2}} \frac{\partial \theta'}{\partial x} \right) \sqrt{1 - x^2} \\ &= \frac{\partial^2 \theta'}{\partial x^2} (1 - x^2) - x \frac{\partial \theta'}{\partial x} \end{aligned} \quad (14)$$

Substituting the value of $\frac{\partial \theta'}{\partial \theta}$ from equation (13) and the value of $\frac{\partial^2 \theta'}{\partial \theta^2}$ from (14) in (12), we get:

$$\frac{\partial}{\partial \theta} \left(\sin \theta \frac{\partial \theta'}{\partial \theta} \right) = \sin \theta \left[\frac{\partial^2 \theta'}{\partial x^2} (1 - x^2) - x \frac{\partial \theta'}{\partial x} \right] - x \frac{\partial \theta'}{\partial x} \sqrt{1 - x^2} \quad (15)$$

Thus equation (11) becomes:

$$m(m + 1) \theta' + \frac{\partial^2 \theta'}{\partial x^2} (1 - x^2) - \frac{\partial \theta'}{\partial x} (x + x) = 0,$$

or,
$$\frac{\partial^2 \theta'}{\partial x^2} (1 - x^2) - 2x \frac{\partial \theta'}{\partial x} + m(m + 1) \theta' = 0 \quad (16)$$

This equation, which very important, is called **LEGENDRE'S** equation.

It can also be written:

$$\frac{\partial}{\partial x} \left[(1 - x^2) \frac{\partial \theta'}{\partial x} \right] + m(m + 1) \theta' = 0 \tag{17}$$

since,
$$\frac{\partial}{\partial x} \left[(1 - x^2) \frac{\partial \theta'}{\partial \theta} \right] = \frac{\partial^2 \theta'}{\partial x^2} (1 - x^2) - 2x \frac{\partial \theta'}{\partial x}.$$

Assume now that θ' can be expressed in whole powers of x multiplied by constant coefficients, that is,

$$\theta' = \Sigma a_n x^n = a_0 + a_1 x' + a_2 x^2 + a_3 x^3 + \dots \tag{18}$$

Referring to equation (17),

$$\begin{aligned} \frac{\partial \theta'}{\partial \theta} &= a_1 + 2a_2 x + 3a_3 x^2 + \dots, \\ (1 - x^2) \frac{\partial \theta'}{\partial x} &= a_1 - a_1 x^2 + 2a_2 x - 2a_2 x^3 + 3a_3 x^2 - 3a_3 x^4 \dots, \\ \frac{\partial}{\partial x} (1 - x^2) \frac{\partial \theta'}{\partial x} &= -2a_1 x + 2a_2 - 6a_2 x^2 + 6a_3 x - 12a_3 x^3 + \dots, \\ \text{and,} \\ m(m + 1) \theta' &= m(m + 1)a_0 + m(m + 1)a_1 x' + m(m + 1)a_2 x^2 + \\ &\quad m(m + 1) \cdot a_3 x^3 + \dots \end{aligned}$$

Collecting the coefficient for similar powers of x we get:

$$\begin{aligned} [2a_2 + m(m + 1)a_0] &\text{ is the constant term;} \\ [6a_3 - 2a_1 + m(m + 1)a_1] &\text{ is the coefficient of } x^1; \\ [-6a_2 + 12a_4 + m(m + 1)a_2] &\text{ is the coefficient of } x^2; \\ \dots &\dots \end{aligned}$$

Since, from equation (17), each of these coefficients is zero, we get:

$$\begin{aligned} a_2 &= -\frac{m(m + 1)a_0}{2} = -\frac{m(m + 1)a_0}{2}, \\ a_3 &= -\frac{m(m + 1)a_1 + 2a_1}{6} = -\frac{m(m + 1) + 2}{6} a_1, \\ a_4 &= -\frac{m(m + 1)a_2 + 6a_2}{12} = -\frac{m(m + 1) + 6}{12} a_2, \text{ etc.} \end{aligned}$$

It is seen that if $a_0 = 0$, all the even terms disappear; if $a_1 = 0$, the odd terms disappear.

The coefficients are related in a comparably simple manner, as follows:

$$a_{k+2} = - \frac{1}{(k+1)(k+2)} [m(m+1) - k(k+1)] a_k \quad (19)$$

or,

$$\begin{aligned} a_k &= - \frac{(k+1)(k+2)}{m(m+1) - k(k+1)} a_{k+2} \\ &= - \frac{(k+1)(k+2)}{(m-k)(m+k+1)} a_{k+2} \end{aligned} \quad (20)$$

From (20) it follows, that, if $k = m - 2$,

$$\begin{aligned} a_{m-2} &= - \frac{(m-2+1)(m-2+2)}{(m-m+2)(m+m-2+1)} a_m = - \frac{m(m-1)}{2(2m-1)} a_m; \\ a_{m-4} &= + \frac{m(m-1)(m-2)(m-3)}{2 \cdot 4(2m-1)(2m-3)} a_m; \\ a_{m-6} &= - \frac{m(m-1)(m-2)(m-3)(m-4)(m-5)}{2 \cdot 4 \cdot 6(2m-1)(2m-3)(2m-5)} a_m; \text{ etc.} \end{aligned}$$

It is thus possible to express equation (18) as follows: $\theta' = \Sigma a_n x^n$; if the highest power of x is x^m , then we get:

$$\theta' = a_m \left[x^m - \frac{m}{2} \frac{(m-1)}{(2m-1)} x^{m-2} + \frac{m(m-1)(m-2)(m-3)}{2 \cdot 4(2m-1)(2m-3)} x^{m-4} \mp \dots \right] \quad (21)$$

where a_m is entirely arbitrary, and it is convenient to choose a value,

$$a_m = \frac{(2m-1)(2m-3)(2m-5) \dots 1}{m!},$$

because, for this value of a_m , $\theta' = 1$ when $x = 1$.

$$\begin{aligned} \therefore \theta' &= \frac{(2m-1)(2m-3)(2m-5) \dots 1}{m!} \left[x^m - \frac{m(m-1)}{2(2m-1)} x^{m-2} \right. \\ &\quad \left. + \frac{m(m-1)(m-2)(m-3)}{2 \cdot 4(2m-1)(2m-3)} x^{m-4} \mp \dots \right] \end{aligned} \quad (22)$$

Since θ' is a function of x , and contains no higher power of x than x^m , it is customary to write, instead of θ' , $P_m(x)$, or since x was $\cos \theta$, $P_m(\cos \theta)$.

Before enumerating some values of θ' , recollect that (factorial 0) = 1, or $0! = 1$, or $\underline{0} = 1$; and since $\underline{1} = 1$, $\underline{0} = \underline{1} = 1$. This is readily seen since $\frac{\underline{n}}{\underline{n-1}} = n$; for $n = 1$, $\frac{\underline{1}}{\underline{0}} = 1$, $\therefore \underline{0} = 1$.

Example.—Find $P_3(\cos \theta)$.

$$m = 3, \therefore P_3(x) = \frac{(6-1)(6-3)(6-5)}{1 \cdot 2 \cdot 3} \left[x^3 - \frac{3}{2} \cdot \frac{3-1}{6-1} x' \right].$$

Note that only three terms can be used in the numerator in front of the parenthesis, since the last term must end with 1 as is shown in equation (22).

The parenthesis contains only two terms, because the next term would give a negative exponent, and we have assumed that the powers of x are positive integer numbers.

Thus, for $m = 3$,

$$P_3(x) = \frac{5 \cdot 3 \cdot 1}{1 \cdot 2 \cdot 3} (x^3 - \frac{3}{5}x) = \frac{1}{2} (5x^3 - 3x).$$

Similarly, for $m = 2$,

$$P_2(x) = \frac{(4-1)(4-3)}{1 \cdot 2} \left[x^2 - \frac{2}{2} \frac{(2-1)}{(4-1)} \right] = \frac{1}{2} (3x^2 - 1)$$

For $m = 1$,

$$P_1(x) = \frac{2-1}{1} x = x$$

For $m = 0$,

$$P_0(x) = \frac{1}{0!} = 1x^0 = 1$$

(23)

But we assumed as a particular solution:

$$V = r^m \theta' \therefore V = \sum A_m r^m P_m(x), \text{ or } \sum A_m r^m P_m(\cos \theta) \quad (24)$$

or,

$$V = A_0 r^0 P_0(\cos \theta) + A_1 r^1 P_1(\cos \theta) + A_2 r^2 P_2(\cos \theta) + A_3 r^3 P_3(\cos \theta) + \dots \quad (25)$$

Referring now to equation (10), we see that there is also another particular solution, namely:

$$R' = \frac{1}{r^{m+1}} \therefore V = \theta' R' = \sum \frac{A_m}{r^{m+1}} P_m(\cos \theta);$$

or,

$$V = \frac{A_0 P_0(\cos \theta)}{r} + \frac{A_1 P_1(\cos \theta)}{r^2} + \frac{A_2 P_2(\cos \theta)}{r^3} + \frac{A_3 P_3(\cos \theta)}{r^4} + \dots \quad (26)$$

Before applying these equations to some practical problems, it may be of interest to note that the LEGENDRE'S function can be

obtained by expanding $\frac{1}{R'}$, where R' is the distance between two points (Fig. 85).

$$R' = \sqrt{r^2 + r_1^2 - 2rr_1 \cos \theta}.$$

If $r_1 > r$,
$$\frac{1}{R'} = \frac{1}{r_1} \left[\frac{r^2}{r_1^2} + 1 - \frac{2r}{r_1} \cos \theta \right]^{-\frac{1}{2}} = \frac{A}{r_1},$$

where
$$A = (1 + h^2 - 2hp)^{-\frac{1}{2}},$$

where
$$h = \frac{r}{r_1}$$

and
$$P = \cos \theta.$$

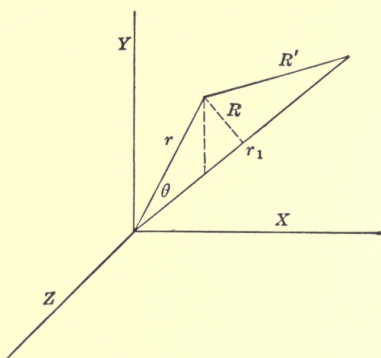

FIG. 85.

Expanding A by the binomial theorem, we get:

$$\begin{aligned} &= 1 + hp + h^2 \frac{1}{2}(3p^2 - 1) + h^3 \frac{1}{2}(5p^3 - 3p) + \dots \\ &= P_0 + hP_1 + h^2P_2 + h^3P_3 + \dots \end{aligned} \quad (27)$$

The similarity between (23) and (27) is obvious.

Returning now to the problem of a circular wire carrying current, we have shown that the potential at a point on the axis, that is, r coincides with y -axis and $\theta = 0$, is:

$$V = 2\pi I \left[1 - \frac{r}{\sqrt{R^2 + r^2}} \right],$$

where r and R are shown in Fig. 86.

If $R > r$, see Fig. 86, then

$$V = 2\pi I \left[1 - \frac{r}{R} \left(1 + \frac{r^2}{R^2} \right)^{-\frac{1}{2}} \right].$$

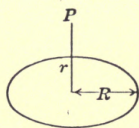

FIG. 86.

Remembering that when $\frac{r^2}{R^2} = K$ is a fraction

$$(1 + k)^{-\frac{1}{2}} = 1 - \frac{1}{2}k + \frac{1 \cdot 3}{2 \cdot 4}k^2 - \frac{1 \cdot 3 \cdot 5}{2 \cdot 4 \cdot 6}k^3 \pm \dots$$

$$V = 2\pi I \left[1 - \frac{r}{R} + \frac{1}{2} \frac{r^3}{R^3} - \frac{1 \cdot 3}{2 \cdot 4} \frac{r^5}{R^5} + \frac{1 \cdot 3 \cdot 5}{2 \cdot 4 \cdot 6} \frac{r^7}{R^7} \mp \dots \right]$$

Since equation (23) holds for all values of θ , it also holds when $\theta = 0$. Thus we can readily determine the coefficients A_0, A_1, A_2 , etc., which are:

$$A_0 = 2\pi I,$$

$$A_1 = -\frac{2\pi I}{R},$$

$$A_2 = 0,$$

$$A_3 = 2\pi I \frac{1}{2R^3},$$

$$A_4 = 0,$$

$$A_5 = -2\pi I \cdot \frac{3}{8R^5},$$

$$A_6 = 0,$$

$$A_7 = +2\pi I \cdot \frac{5}{16R^7},$$

$$\therefore V = 2\pi I \left[1 - \frac{r}{R} P_1(\cos \theta) + \frac{1}{2} \frac{r^3}{R^3} P_3(\cos \theta) - \frac{3}{8} \frac{r^5}{R^5} P_5(\cos \theta) + \frac{5}{16} \cdot \frac{r^7}{R^7} P_7(\cos \theta) \mp \dots \right] \quad (28)$$

If $r > R$, then,

$$\begin{aligned} V &= 2\pi I \left[1 - \left(1 + \frac{R^2}{r^2} \right)^{-\frac{1}{2}} \right] \\ &= 2\pi I \left[1 - 1 + \frac{1}{2} \frac{R^2}{r^2} - \frac{1 \cdot 3}{2 \cdot 4} \frac{R^4}{r^4} + \frac{1 \cdot 3 \cdot 5}{2 \cdot 4 \cdot 6} \frac{R^6}{r^6} \mp \dots \right] \\ &= 2\pi I \left[\frac{1}{2} \frac{R^2}{r^2} - \frac{3}{8} \frac{R^4}{r^4} + \frac{5}{16} \frac{R^6}{r^6} \mp \dots \right] \quad (29) \end{aligned}$$

From equation (26) we get:

$$V = \frac{A_0}{r^1} P_0(\cos \theta) + \frac{A_1}{r^2} P_1(\cos \theta) + A_2 \frac{P_2(\cos \theta)}{r^3} + A_3 \frac{P_3(\cos \theta)}{r^4} + \dots$$

$$\therefore A_0 = 0,$$

$$A_1 = 2\pi I \cdot \frac{R^2}{2},$$

$$\begin{aligned} A_2 &= 0, \\ A_3 &= -2\pi I \cdot \frac{3}{8} R^4, \\ A_5 &= 0, \\ A_6 &= 2\pi I \cdot \frac{5}{16} R^6, \\ &\dots \end{aligned}$$

$$\therefore V = 2\pi I \left[\frac{1}{2} \frac{R^2}{r^2} P_1(\cos \theta) - \frac{3}{8} \frac{R^4}{r^4} P_3(\cos \theta) + \frac{5}{16} \frac{R^6}{r^6} P_5(\cos \theta) + \dots \right] \quad (30)$$

As a second application of the use of the LEGENDRE'S function, the following problem will be considered.

Find the potential at points outside of a thin circular disc, Fig. 87, charged to a certain potential, V .

It will be proven that the distribution of the surface charge is:

$$\sigma = \frac{Q}{4\pi R} \cdot \frac{1}{\sqrt{R^2 - r_0^2}},$$

where Q is the total charge, that is, the charge on both sides.

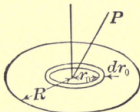

FIG. 87.

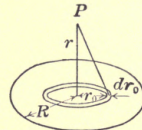

FIG. 88.

We first calculate the potential at a point P_1 on the axis (Fig. 88).

$$\begin{aligned} V_{P_1} &= \int_{r_0=R}^{r_0=0} \frac{2\pi r_0 dr_0 2\sigma}{\sqrt{r^2 + r_0^2}} = \int_{r_0=R}^{r_0=0} \frac{2\pi r_0 dr_0}{\sqrt{r^2 + r_0^2}} \cdot \frac{2Q}{4\pi R \sqrt{R^2 - r_0^2}} \\ &= \frac{Q}{2R} \cos^{-1} \frac{r^2 - R^2}{r^2 + R^2}, \end{aligned}$$

as can be readily found by simple integration.

This expression then must be expanded in a power series.

This can not be readily done, but its derivative with respect to r becomes a simple expression, which can be expanded, the resulting series can be readily integrated. Thus,

$$\frac{d}{dr} \left[\frac{Q}{2R} \cos^{-1} \frac{r^2 - R^2}{r^2 + R^2} \right] = - \frac{Q}{R^2 + r^2}.$$

If $R > r$, then

$$- \frac{Q}{R^2 + r^2} = - \frac{Q}{R^2} \left[1 - \frac{r^2}{R^2} + \frac{r^4}{R^4} - \frac{r^6}{R^6} + \dots \right]$$

Integrating,

$$\begin{aligned} V &= -\frac{Q}{R^2}\left[r - \frac{r^3}{3R^2} + \frac{r^5}{5R^4} = \dots + C'\right] \\ &= \frac{Q}{R}\left[-\frac{r}{R} + \frac{r^3}{3R^3} - \frac{r^5}{5R^5} - \dots + C\right]. \end{aligned}$$

For $r = 0$, *i.e.*, on the disc, and the potential of the disc will be proven to be $\frac{\pi}{2} \cdot \frac{Q}{R}$,

$$\therefore C = \frac{\pi}{2}$$

$$\therefore V = \frac{Q}{R}\left[\frac{\pi}{2} - \frac{r}{R} + \frac{r^3}{3R^3} + \frac{r^5}{5R^5} - \dots\right] \quad (31)$$

when $r > R$, it is found in a similar way that:

$$V = \frac{Q}{R}\left[\frac{R}{r} - \frac{R^3}{3r^3} + \frac{R^5}{5r^5} - \frac{R^7}{7r^7} + \dots\right] \quad (32)$$

Equation (31) is similar to:

$$V = A_0 r^0 P_0(\cos \theta) + A_1 r^1 P_1(\cos \theta) + A_2 r^2 P_2(\cos \theta) + \dots$$

$$\therefore A_0 = \frac{Q}{R} \cdot \frac{\pi}{2}, A_1 = -\frac{Q}{R} \cdot \frac{1}{R}, A_2 = 0, A_3 = \frac{Q}{R} \cdot \frac{1}{3R^3}, A_4 = 0, \text{etc.}$$

$$\therefore V = \frac{Q}{R}\left[\frac{\pi}{2} P_0(\cos \theta) - \frac{r}{R} P_1(\cos \theta) + \frac{r^3}{3R^3} P_2(\cos \theta) - \frac{r^5}{5R^5} P_5(\cos \theta) + \dots\right].$$

Equation (32) is similar to:

$$V = \frac{A_0 P_0 \cos \theta}{r^1} + \frac{A_1 P_1(\cos \theta)}{r^2} + \frac{A_2 P_2(\cos \theta)}{r^3} + \dots$$

$$\therefore A_0 = \frac{Q}{r} \cdot R, A_1 = 0, A_2 = -\frac{Q}{r} \frac{R^3}{3}, A_3 = 0, A_4 = \frac{Q}{r} \cdot \frac{R^5}{5}, \text{etc.},$$

$$\therefore V = \frac{Q}{R}\left[\frac{R}{r} P_0(\cos \theta) - \frac{R^3}{3r^3} P_2(\cos \theta) + \frac{R^5}{5r^5} P_4(\cos \theta) - \dots\right].$$

CHAPTER XVII

DISTRIBUTION OF CHARGE ON AN ELLIPSOID

If an ellipsoidal thin shell is formed by two similar, similarly situated ellipsoids, and the charge per unit volume, ρ , is constant in the shell, then the force at any point inside the ellipsoid is zero, that is the potential is constant. The outer surface is an equipotential surface.¹

To prove this, consider the attraction at o of the two masses at A and B , Fig. 89.

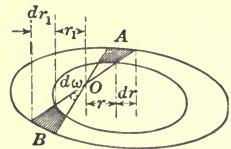

FIG. 89.

The volume at A is $r^2 d\omega dr$ \therefore charge, $q = \rho r^2 d\omega dr$.

The volume of B is $r_1^2 d\omega dr$ \therefore charge $q' = \rho r_1^2 d\omega dr$

\therefore The attraction of A at O is $\frac{q}{r^2} = \rho d\omega dr$.

The attraction of B at O is $\frac{q'}{r_1^2} = \rho d\omega dr_1$.

But from geometry it is known that with two ellipsoids, one of axes a, b and c , and the other of $a(1 + \alpha), b(1 + \alpha)$ and $c(1 + \alpha)$, that is, with two similar, similarly situated concentric ellipsoids, dr must always be equal to dr_1 . Thus the attraction at O must be zero.

In the case of a conducting ellipsoid charged with electricity, the charge is confined to the surface and the distribution will be shown to be such as is represented by the thickness of the shell in Fig. 89. It is greatest where the curvature is greatest and least on the flat point of the surface.

The problem then is to express the thickness of the shell in terms of a variable surface charge, σ .

The volume of the shell is evidently $= \frac{4}{3}\pi abc [(1 + \alpha)^3 - 1]$; considering uniform volume charge, the total charge is:

$$Q = \frac{4\pi abc}{3} [(1 + \alpha)^3 - 1]\rho.$$

¹ NOTE.—See "Analytical Statics," vol. II, by ROUTH.

But $\sigma = \rho\delta$, where δ is the variable thickness of the shell,

$$\therefore Q = \frac{4\pi abc}{3} [(1 + \alpha)^3 - 1] \frac{\rho}{\delta}$$

or

$$\sigma = \frac{3Q\delta}{4\pi abc (\alpha^3 + 3\alpha^2 + 3\alpha)} = \frac{Q\delta}{4\pi abc \alpha \left(\frac{\alpha^2}{3} + \alpha^2 + 1 \right)}$$

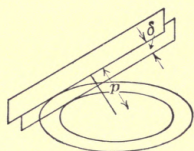

FIG. 90.

But the thickness of the shell δ can be expressed as the distance between two parallel planes going through any point of the shell.

We have from geometry (see Fig. 90) that the distance from the center of an ellipsoid to a tangent plane is:

$$p = \frac{1}{\sqrt{\frac{x^2}{a^4} + \frac{y^2}{b^4} + \frac{z^2}{c^4}}} \quad (1)$$

Neglecting infinitesimals of higher order than the first, $\delta = p(1 + \alpha) - p = p\alpha$.

$$\therefore \sigma = \frac{Qp}{4\pi abc \left(\frac{\alpha^2}{3} + \alpha + 1 \right)}; \text{ or at the limit } \alpha = 0,$$

$$\sigma = \frac{Qp}{4\pi abc}.$$

Consider now a very thin flat elliptic disc in the $x - y$ plane (c is small) we have from (1)

$$\frac{p}{c} = \frac{1}{\sqrt{c^2 \left(\frac{x^2}{a^4} + \frac{y^2}{b^4} \right) + \frac{z^2}{c^2}}} = \frac{1}{\sqrt{c^2 \left(\frac{x^2}{a^4} + \frac{y^2}{b^4} \right) + 1 - \frac{x^2}{a^2} - \frac{y^2}{b^2}}}$$

$$\therefore \sigma = \frac{Q}{4\pi ab \sqrt{c^2 \left(\frac{x^2}{a^4} + \frac{y^2}{b^4} \right) + 1 - \frac{x^2}{a^2} - \frac{y^2}{b^2}}}$$

when c approaches zero,

$$\sigma = \frac{Q}{4\pi ab} \cdot \frac{1}{\sqrt{1 - \frac{x^2}{a^2} - \frac{y^2}{b^2}}}$$

As a consequence for a circular disc,

$$\sigma = \frac{Q}{4\pi R \sqrt{R^2 - r^2}},$$

where R is the radius of the disc and r the particular distance from the center, where σ is the surface density on the disc.

To find the potential of the circular disc, we calculate the potential at a point on the axis, Fig. 91.

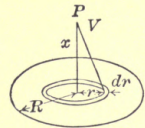

FIG. 91.

$$V = - \int_{r=R}^{r=0} \frac{2\pi r dr 2\sigma}{\sqrt{x^2 + r^2}} = - 4\pi \int_R^0 \frac{r dr Q}{4\pi R \sqrt{R^2 - r^2} \sqrt{x^2 + r^2}}$$

$$= - \frac{Q}{R} \int_R^0 \frac{r dr}{\sqrt{(R^2 - r^2)(x^2 + r^2)}}$$

In this equation, x is, of course, a constant, being the distance from the disc at which the potential is to be determined:

On the disc, $x = 0$,

$$\therefore V = - \frac{Q}{R} \int_R^0 \frac{r dr}{r \sqrt{R^2 - r^2}}$$

$$= - \frac{Q}{R \sqrt{R^2 - r^2}} = - \frac{Q}{R} \sin^{-1} \frac{r}{R} \Big|_{r=R}^{r=0} = \frac{Q}{R} \frac{\pi}{2}.$$

Incidentally, since the capacity is $\frac{Q}{V}$, it follows that the capacity of a disc is $\frac{2}{\pi} R$, which is $2/\pi$ times that of a sphere of the same radius.

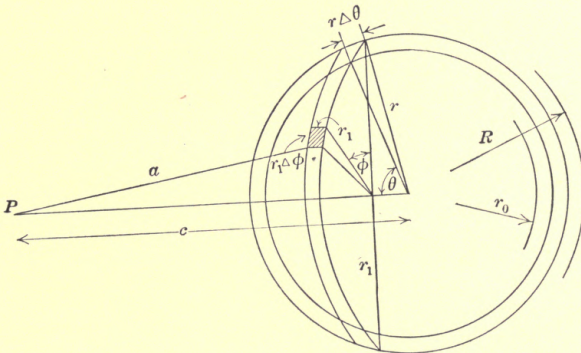

FIG. 92.

Potentials, Outside and Inside, and in the Body of a Spherical Shell.—Let the uniform charge per unit volume of the mass of the shell be ρ , and the inner radius r_0 and the outer radius R , Fig. 92.

The area of the shaded surface, Fig. 92, is $r_1 \Delta \phi \cdot r \Delta \theta$

$$= r \sin \theta \cdot \Delta \phi \cdot r \Delta \theta;$$

the volume of an element of thickness Δr is:

$$r^2 \sin \theta \Delta \phi \Delta \theta \Delta r.$$

If ρ is the charge per unit volume, then the charge on the small volume is:

$$q = \rho r^2 \sin \theta \Delta \phi \Delta \theta \Delta r.$$

Thus the potential function at P due to the charge on the small volume is:

$$\begin{aligned} V &= \frac{q}{a}, \text{ but } a = \sqrt{r_1^2 + (c - r \cos \theta)^2} \\ &= \sqrt{c^2 + r^2 \sin^2 \theta + r^2 \cos^2 \theta - 2cr \cos \theta} \\ &= \sqrt{c^2 + r^2 - 2cr \cos \theta}; \end{aligned}$$

$$\text{or, } a^2 = c^2 + r^2 - 2cr \cos \theta \quad (1)$$

$$V = \frac{\Sigma q}{a} = \int_{r=r_0}^{r=R} \int_{\varphi=0}^{\varphi=2\pi} \int_{\theta=0}^{\theta=\pi} \frac{\rho r^2 \sin \theta dr d\phi d\theta}{\sqrt{c^2 + r^2 - 2cr \cos \theta}} \quad (2)$$

From (1), $a^2 = c^2 + r^2 - 2cr \cos \theta$,

$$\therefore 2ada = 2cr \sin \theta d\theta$$

$$\text{or, } \sin \theta d\theta = \frac{ada}{cr} \quad (3)$$

Substitute (3) and (1) in (2),

$$\begin{aligned} V &= \int_{r=r_0}^{r=R} \int_{\varphi=0}^{\varphi=2\pi} \int_{a=c-r}^{a=c+r} \frac{\rho r^2 a da dr d\phi}{acr} \\ &= \int_{r=r_0}^{r=R} \int_{\varphi=0}^{\varphi=2\pi} \int \frac{\rho r da dr d\phi}{c} \\ &= \frac{\rho}{c} \int_{r=r_0}^{r=R} \int_{\varphi=0}^{\varphi=2\pi} r[(c+r) - (c-r)] dr d\theta \quad (4) \end{aligned}$$

$$\begin{aligned} &= \frac{2\rho}{c} \int_{r=r_0}^{r=R} \int_{\varphi=0}^{\varphi=2\pi} r^2 dr d\varphi \\ &= \frac{2\rho}{c} \int_{r=r_0}^{r=R} 2\pi r^2 dr \\ &= \frac{4\pi\rho}{c} \left(\frac{R_1^3}{3} - \frac{r_0^3}{3} \right) = \frac{\rho(\text{volume of shell})}{c} = \frac{Q}{c} \quad (5) \end{aligned}$$

If point P had been inside of the shell, then the limits of integration of a would be $r - c$ and $r + c$.

∴ Equation (4) would be:

$$\begin{aligned}
 V &= \frac{\rho}{c} \int_{r=r_0}^{r=R} \int_{\varphi=0}^{\varphi=2\pi} r[(r+c) - (r-c)] dr d\varphi. \\
 &= \frac{2\rho}{c} \int_{r=r_0}^{r=R} \int_{\varphi=0}^{\varphi=2\pi} cr dr d\varphi \\
 &= 4\pi\rho \int_{r=r_0}^{r=R} r dr. \\
 &= 2\pi\rho (R^2 - r_0^2),
 \end{aligned} \tag{6}$$

which is independent upon c , the position of the point P .

Thus the potential is constant inside of a hollow sphere.

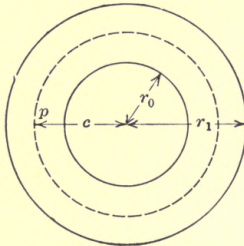

FIG. 93.

If the point had been in the body of the shell, Fig. 93, then the potential would be the sum of the potentials due to the mass outside and inside of the spherical surface which contains P .

$$\begin{aligned}
 \therefore V &= \frac{4\pi\rho}{c} - \frac{c^3 - r_0^3}{3} + 2\pi\rho(R^2 - c^2) \\
 &= 2\pi\rho \left(R^2 - \frac{C^3 + 2r_0^3}{3c} \right)
 \end{aligned} \tag{7}$$

The field intensity or potential gradient is:

$$G = - \frac{dV}{dc}.$$

(The signs should all be reversed for gravitational potentials.)

In the case of the point being outside the sphere,

$$\begin{aligned}
 G &= - \frac{dV}{dc} = \frac{Q}{c^2} = \frac{4\pi\rho}{3c^2}(R^3 - r_0^3) \\
 \text{and} \quad \frac{d^2V}{dc^2} &= - \frac{2Q}{c^3} = \frac{8\pi\rho}{3c^3}(R^3 - r_0^3)
 \end{aligned} \tag{8}$$

In the case where the point is inside, it is:

$$G = - \frac{dV}{dc} = 0, \text{ and } \frac{d^2V}{dc^2} = 0 \tag{9}$$

where the point is in the shell then:

$$\left. \begin{aligned} G = -\frac{dV}{dc} &= -2\pi\rho \left[-\frac{2c^2}{3} + \frac{2r_0^3}{3c} \right] = \frac{4\pi\rho}{3} \cdot \frac{r_0^3 - c^3}{c^2}; \\ \frac{d^2V}{dc^2} &= -\frac{4\pi\rho}{3} \left[-\frac{2r_0^3}{c^3} - 1 \right] = \frac{4\pi\rho}{3} \cdot \frac{2r_0^3 + c^3}{c^3} \end{aligned} \right\} (10)$$

Problem.—Plot the potential, the potential gradient, and $\frac{d^2V}{dc^2}$ when $V = 1$ at the center;

$$r_1 = 1;$$

$$r_0 = 0.5$$

in the case shown in Fig. 94.

For a full discussion see WEBSTER'S "Electricity and Magnetism."

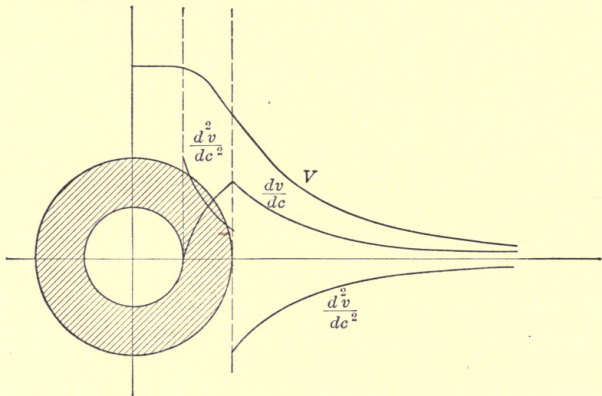

FIG. 94.

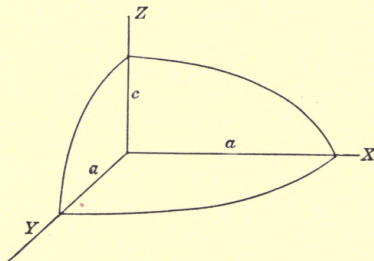

FIG. 95.

Potential Outside of a Non-conducting Charged Oblate Ellipsoid.

—Let the equation of the oblate ellipsoid, Fig. 95, be:

$$\frac{x^2}{a^2} + \frac{y^2}{a^2} + \frac{z^2}{c^2} = 1.$$

Let the total charge of the ellipsoid be Q , and the potential on the surface be V_0 .

The surface intensity at the element ring, generated by ds , Fig. 96, revolved about the z -axis, has been proven to be:

$$\sigma = \frac{pQ}{4\pi a^2 c}$$

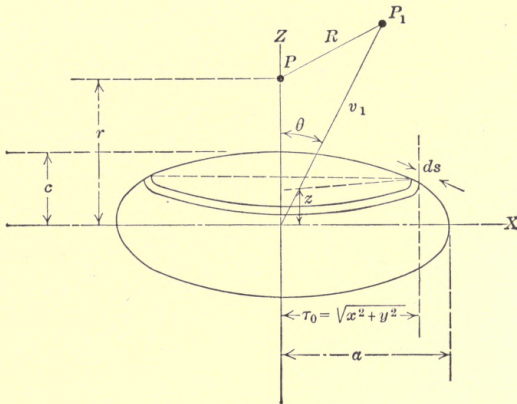

FIG. 96.

where p is the distance from the origin to ds , and

$$\frac{1}{p} = \sqrt{\frac{x^2}{a^4} + \frac{y^2}{a^4} + \frac{z^2}{c^4}} = \sqrt{\frac{r_0^2}{a^4} + \frac{z^2}{c^4}}$$

where $r_0 = \sqrt{x^2 + y^2}$,

$$\therefore \sigma = \frac{Q}{4\pi a^2 c \sqrt{\frac{r_0^2}{a^4} + \frac{z^2}{c^4}}} \tag{2}$$

$$ds = \sqrt{(dr_0)^2 + (dz)^2} = dz \sqrt{1 + \left(\frac{dr_0}{dz}\right)^2}$$

From (1), $\frac{r_0^2}{a^2} + \frac{z^2}{c^2} = 1$.

Differentiating, $\frac{2r_0 dr_0}{a^2} + \frac{2z dz}{c^2} = 0$,

or, $\left(\frac{dr_0}{dz}\right)^2 = \left(\frac{a}{c}\right)^4 \cdot \left(\frac{z}{r_0}\right)^2$.

$$\therefore ds = \sqrt{1 + \left(\frac{a}{c}\right)^4 \left(\frac{z}{r_0}\right)^2} dz = \frac{a^2}{r_0} \sqrt{\frac{r_0^2}{a^4} + \frac{z^2}{c^4}} dz \tag{3}$$

The potential at P on the axis due to the ring-shaped element surface is:

$$= \frac{2\pi r_0 \sigma ds}{\sqrt{(r-z)^2 + r_0^2}} \quad (4)$$

Substituting (2) and (3) in (4) we get: the potential at P due to the whole ellipsoid

$$= \int_{z=-c}^{z=c} \frac{Q dz}{2c \sqrt{(r-z)^2 + r_0^2}} \quad (5)$$

From the equation of the ellipsoid,

$$r_0^2 = \frac{a^2}{c^2}(c^2 - z^2),$$

substituting in (5),

$$\begin{aligned} V_p &= \int_{-c}^c \frac{Q dz}{2c \sqrt{(r-z)^2 + \frac{a^2}{c^2}(c^2 - z^2)}} \\ &= \int_{-c}^c \frac{Q dz}{2\sqrt{a^2 - c^2} \sqrt{-(a^2 - c^2)z^2 - 2rc^2z + c^2(a^2 + r^2)}} \\ &= \frac{Q}{2\sqrt{a^2 - c^2}} \left[\sin^{-1} \frac{(a^2 - c^2)z + rc^2}{ca\sqrt{a^2 - c^2 + r^2}} \right]_{-c}^c \\ &= \frac{Q}{2\sqrt{a^2 - c^2}} \left[\sin^{-1} \frac{a^2 - c^2 + rc}{a\sqrt{a^2 - c^2 + r^2}} - \sin^{-1} \frac{-a^2 + c^2 + rc}{a\sqrt{a^2 - c^2 + r^2}} \right] \quad (6) \end{aligned}$$

To find the potential at a point, like P_1 , which is not on the z -axis, LEGENDRE'S function may be employed, and the equation (6) is to be expanded into a series in the terms of r . In order to obtain an expression which may be easily expanded, differentiate (6) with respect to r , expand the result into a series, and then integrate the series. Thus differentiating (6),

$$\frac{dV_p}{dr} = - \frac{Q}{(a^2 - c^2 + r^2)} \quad (7)$$

Expanding (7),

$$\frac{dV_p}{dr} = \frac{-Q}{a^2 - c^2} \left[1 - \frac{r^2}{a^2 - c^2} + \frac{r^4}{(a^2 - c^2)^2} - \frac{r^6}{(a^2 - c^2)^4} \pm \dots \right],$$

when

$$c < r < \sqrt{a^2 - c^2} \quad (8)$$

$$\begin{aligned} V_P &= \frac{Q}{\sqrt{a^2 - c^2}} \left[- \frac{c}{\sqrt{a^2 - c^2}} + \frac{1}{3} \left(\frac{c}{\sqrt{a^2 - c^2}} \right)^3 - \right. \\ &\quad \left. \frac{1}{5} \left(\frac{c}{\sqrt{a^2 - c^2}} \right)^5 \pm \dots + C \right]. \end{aligned}$$

For a point on the surface, i.e., when $r = c$,

$$V_0 = \frac{Q}{\sqrt{a^2 - c^2}} \left[C - \tan^{-1} \frac{c}{\sqrt{a^2 - c^2}} \right],$$

$$\therefore C = V_0 \frac{\sqrt{a^2 - c^2}}{Q} + \tan^{-1} \frac{c}{\sqrt{a^2 - c^2}} \tag{10}$$

Since V_{P_1} is a function of V_P and R , the solution for V_{P_1} takes the following form:

$$V_{P_1} = A_0 + A_1 r_1 P_1(\cos \theta) + A_2 r_1^2 P_2(\cos \theta) + A_3 r_1^3 P_3(\cos \theta) + \dots$$

When

$$\theta = 0, r_1 = r, P_1 = P_2 = P_3 = \dots = 1, \text{ and } V_{P_1} = V_P.$$

$$\therefore A_0 = Q \left[\frac{V_0}{Q} + \frac{1}{Q\sqrt{a^2 - c^2}} \tan^{-1} \frac{c}{\sqrt{a^2 - c^2}} \right];$$

$$A_1 = -\frac{Q}{a^2 - c^2};$$

$$A_2 = 0;$$

$$A_3 = \frac{1}{3} \frac{Q}{(a^2 - c^2)^2};$$

$$A_4 = 0;$$

$$A_5 = -\frac{1}{5} \frac{Q}{(a^2 - c^2)^3};$$

$$\therefore V_{P_1} = Q \left[\left(\frac{V_0}{Q} + \frac{1}{Q\sqrt{a^2 - c^2}} \tan^{-1} \frac{c}{\sqrt{a^2 - c^2}} \right) - \frac{P_1(\cos \theta)}{(a^2 - c^2)} r_1 + \frac{P_3(\cos \theta)}{3(a^2 - c^2)^2} r_1^3 - \frac{P_5(\cos \theta)}{5(a^2 - c^2)^3} r_1^5 + \frac{P_7(\cos \theta)}{7(a^2 - c^2)^4} r_1^7 + \dots \right],$$

which is applicable, when

$$r_1 < \sqrt{a^2 - c^2} \tag{11}$$

When

$$r > \sqrt{a^2 - c^2},$$

expanding (7),

$$V_P = Q \left[\frac{1}{r} - \frac{(a^2 - c^2)}{3r^3} + \frac{(a^2 - c^2)^2}{5r^5} - \frac{(a^2 - c^2)^3}{7r^7} + \dots + C \right].$$

When $r = \infty, V_P = 0, \therefore C = 0.$

And

$$V_{P_1} = \frac{A_0}{r_1} + \frac{A_1 P_1(\cos \theta)}{r_1^2} + \frac{A_2 P_2^2(\cos \theta)}{r_1^3} + \frac{A_3 P_3(\cos \theta)}{r_1^4} + \dots$$

When $\theta = 0$, $P_1 = P_2 = P_3 = \dots = 1$, $r_1 = r$, and $V_{P_1} = V_P$,
 $\therefore A_0 = Q$;

$$A_1 = 0;$$

$$A_2 = -\frac{Q(a^2 - c^2)}{3};$$

$$A_3 = 0;$$

$$A_4 = \frac{Q(a^2 - c^2)^2}{5};$$

$$A_5 = 0;$$

$$A_6 = -\frac{Q(a^2 - c^2)^3}{7};$$

.....

$$\therefore V_{P_1} = Q \left[\frac{1}{r_1} - \frac{(a^2 - c^2) P_2 (\cos \theta)}{3r_1^3} + \frac{(a^2 - c^2)^2 P_4 (\cos \theta)}{5r_1^5} - \frac{(a^2 - c^2)^3 P_6 (\cos \theta)}{7r_1^7} + \dots \right],$$

which is applicable, when

$$r_1 > \sqrt{a^2 - c^2}. \quad (12)$$

(Two similar series can be derived for an oblong ellipsoid. For this and the potential at a point inside an ellipsoid, see W. E. BYERLY'S "Series.")

CHAPTER XVIII

CONCENTRIC SPHERES

Fig. 97 represents a system of concentric spherical shells. It is desired to find the potential at any point in the medium (which is assumed free from charge).

Since we are dealing with spherical bodies and since the body is symmetrical, indeed a sphere, LAPLACE'S equation in spherical coördinates becomes:

$$\frac{\partial^2 V}{\partial r^2} + \frac{2}{r} \frac{\partial V}{\partial r} = 0 \quad (\text{see appendix}) \quad (1)$$

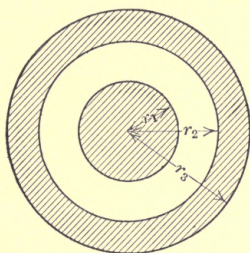

FIG. 97.

To solve this equation, one first ascertains if the relation

$$\frac{\partial V}{\partial r} = \frac{A}{r^2}$$

is satisfactory. (We may well assume this solution, since it can be expected that the intensity or force on unit charge varies inversely as the square of the distance.)

Then,

$$\frac{\partial^2 V}{\partial r^2} = -\frac{2A}{r^3}.$$

Substitute in (1) to see if the solution satisfies the equation

$$-\frac{2A}{r^3} + \frac{2}{r} \frac{A}{r^2} = 0, \text{ Q.E.D.}$$

Thus,

$$\frac{\partial V}{\partial r} = \frac{A}{r^2}$$

satisfies the equation (1).

$$\therefore V = A \int \frac{dr}{r^2} \text{ or, } V = -\frac{A}{r} + B \quad (2)$$

Or we might have solved the equation as follows:

Let

$$y = \frac{dV}{dr} \quad \therefore \frac{d^2V}{dr^2} = \frac{dy}{dr}$$

$$\therefore \frac{dy}{dr} + \frac{2}{r}y = 0.$$

$$\therefore y = A\epsilon^{-\int \frac{2}{r} dr} = A\epsilon^{-\log r^2} = \frac{A}{\epsilon \log r^2} = \frac{A}{r^2}.$$

$$\therefore V = -\int \frac{A}{r^2} dr = -\frac{A}{r} + B.$$

Or again we might have developed the equation directly, without using LAPLACE'S equation, by assuming a positive charge Q on the inside sphere.

The intensity of the field at a point in the medium at a distance r is then by GAUSS'S theorem:

$$R = \frac{4\pi Q}{4\pi r^2} = \frac{Q}{r^2}.$$

$$\therefore V = -\int R dr = +\frac{Q}{r} + B \quad (3)$$

an equation of the same form as (2).

Referring to equation (2), let V_1 be the potential of the inner sphere of radius r_1 and V_2 that of the outer, then,

$$V_1 = -\frac{A}{r_1} + B,$$

and,

$$V_2 = -\frac{A}{r_2} + B.$$

$$\therefore V_1 - V_2 = A \left[\frac{1}{r_2} - \frac{1}{r_1} \right] = A \left[\frac{r_1 - r_2}{r_1 r_2} \right].$$

$$\therefore A = -\frac{V_1 - V_2}{r_2 - r_1} r_1 r_2 \quad (4)$$

$$\therefore V = \frac{V_1 - V_2}{r_2 - r_1} \cdot \frac{r_1 r_2}{r} + B,$$

where

$$r_1 < r < r_2 \quad (5)$$

To determine the meaning of B assume that the outer shell is grounded, or which is the same, at zero potential, then

$$V_1 = -\frac{A}{r_1} + B,$$

and

$$V_2 = 0 = -\frac{A}{r_2} + B;$$

from (4),

$$A = -\frac{V_1}{r_2 - r_1} r_1 r_2,$$

$$\therefore V_2 = 0 = \frac{V_1 r_1}{r_2 - r_1} + B, \therefore B = -\frac{r_1}{r_2 - r_1} V_1.$$

From (5),

$$\begin{aligned} V &= \frac{V_1}{r_2 - r_1} \frac{r_1 r_2}{r} - \frac{r_1}{r_2 - r_1} V_1 \\ &= \frac{V_1 r_1}{r_2 - r_1} \left[\frac{r_2}{r} - 1 \right] = \frac{V_1 r_1}{r_2 - r_1} \cdot \frac{r_2 - r}{r}. \end{aligned}$$

If the outside sphere is very far off so that r_2 approaches infinity and V_2 zero, then,

$$V_2 = 0, r_2 = \infty;$$

$$V_2 = 0 = -\frac{A}{\infty} + B, \therefore B = 0.$$

$$\therefore V = \frac{V_1}{r_2} \cdot \frac{r_1 r_2}{r} = \frac{V_1 r_1}{r} = \frac{Q_1}{r} \tag{6}$$

The potential gradient in the space between the conductors is:

$$G = -\frac{dV}{dr} = R \int = \frac{V_1 - V_2}{r_2 - r_1} \cdot \frac{r_1 r_2}{r^2} \tag{7}$$

It is the greatest at the surface of the inner sphere, where $r = r_1$.

$$\therefore G_{\max.} = \frac{V_1 - V_2}{r_2 - r_1} \frac{r_2}{r_1} \tag{8}$$

The potential gradient at the inner surface of the outer conductor is evidently:

$$G = \frac{V_1 - V_2}{r_2 - r_1} \cdot \frac{r_1}{r_2}$$

Referring to equation (7),

$$R = \frac{4\pi Q_1}{4\pi r_1^2} = \frac{Q_1}{r_1^2}; \text{ equating to (8),}$$

$$\frac{Q_1}{r_1^2} = \frac{V_1 - V_2}{r_2 - r_1} \frac{r_2}{r_1}$$

$$\therefore Q_1 = \frac{V_1 - V_2}{r_2 - r_1} \cdot r_1 r_2 \tag{9}$$

Example.—Calculate the average potential gradient in the space between two concentric spheres separated by a distance of 2 cm.

Assume that the potential gradient at the surface of the inside conductor is 100 electro-static units per centimeter, that is, just about on the point of glowing.

Consider a concentric sphere, Fig. 98, the inner sphere of which has a charge Q_1 and the outer a charge $Q_0 = Q_2 + Q_3$.

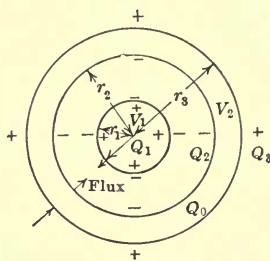

FIG. 98.

Evidently,

$$Q_0 = Q_2 + Q_3.$$

Since all tubes of force beginning at the surface of the inner conductor terminate at the inner surface of the outer conductor, it is evident that the charge $Q_2 = -Q_1$.

$$\therefore Q_0 = -Q_1 + Q_3.$$

The potential at a point outside of the outer conductor is thus, from (6),

$$V = \frac{Q_0}{r} = \frac{Q_3 - Q_1}{r}, \text{ where } r = r_3.$$

Since the capacity of an electric field is the ratio between the charge on the positive boundary and the potential difference between the boundaries,

$$C = \frac{Q_1}{V_1 - V_2}.$$

Thus from (9),

$$C = \frac{V_1 - V_2}{r_2 - r_1} \cdot r_1 r_2 \cdot \frac{1}{V_1 - V_2} = \frac{r_1 r_2}{r_2 - r_1}.$$

The capacity of the inside sphere alone is r_1 .

$$\therefore \frac{\text{Capacity of concentric spheres}}{\text{Capacity of inner sphere}} = \frac{r_2}{r_2 - r_1}.$$

If the thickness of the dielectric is small compared with the radius, then:

$$C = r_1 \frac{(r_1 + \delta)}{\delta} = \frac{r_1^2}{\delta}, \text{ where } \delta = r_2 - r_1.$$

$$\therefore C = \frac{r_1^2}{\delta} = \frac{4\pi r_1^2}{4\pi\delta} = \frac{\text{area of sphere}}{4\pi\delta};$$

as a limiting case, where $r_1 = r_2 = \infty$ we get parallel plates, and,

$$C = \frac{\text{area on one plate}}{4\pi(\text{distance between them})}$$

The capacity is expressed in cm. not in farads. To get the capacity in farads divide C by 9×10^{11}

The energy input to a condenser is:

$$W = \frac{1}{2}CV^2.$$

Thus the energy stored in the field between two concentric spheres, is:

$$W = \frac{1}{2}V^2 \frac{r_1 r_2}{r_2 - r_1}.$$

Infinite Parallel Planes.—LAPLACE'S equation applies in this case so long as there are no charges between the condenser plates,

$$\frac{\partial^2 V}{\partial x^2} + \frac{\partial^2 V}{\partial y^2} + \frac{\partial^2 V}{\partial z^2} = 0.$$

Since the field depends upon the distance between the plates only, that is, upon one of the coördinates only, we get,

$$\frac{\partial^2 V}{\partial x^2} = 0; \therefore \frac{dV}{dx} = C_0$$

and $V = C_0x + C_1.$

If the charge on plate A (Fig. 99) is Q_1 and the potential V_1 ; and the charge on plate B is Q_2 and the potential V_2 ; and if the distance between the plates is d ;

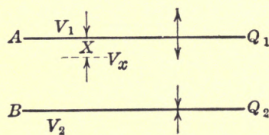

FIG. 99.

We have:

$$V_1 = 0 + C_1,$$

and

$$V_2 = C_0d + C_1.$$

Subtracting,

$$V_1 - V_2 = -C_0d, \text{ or, } C = -\frac{(V_1 - V_2)}{d}.$$

$$\therefore V = -\frac{(V_1 - V_2)}{d}x + C_1; \text{ or, since } V_1 = C_1,$$

$$V_x = V_1 - \frac{[V_1 - V_2]}{d}x.$$

The potential gradient, that is the potential drop per cm. is:

$$G = -\frac{dV}{dx} = \frac{V_1 - V_2}{d} \quad (1)$$

It is constant all through the dielectric.

The total outward flux from A is $4\pi Q_1$, one-half of this enters the space between the plates. The inward flux to B is $4\pi Q_2$, and one-half of this is added to the flux from A . Thus the total flux in the space between the plates is:

$$4\pi \frac{(Q_1 + Q_2)}{2} = 2\pi(Q_1 + Q_2).$$

But the charge on A , Q_1 , must be numerically the same as that on B , Q_2 , since all tubes of force leaving A enter B , thus $Q_1 = Q_2$, numerically, but of course of opposite sign, which, however, is taken care of in the above discussion.

Thus the total flux in the gap is $4\pi Q$, where Q is the charge on one of the plates.

$\therefore R$, the intensity of the field, is $\frac{4\pi Q}{A}$, where A is the area of one side of the plate.

And,

$$G = R = \frac{4\pi Q}{A};$$

or from (1),

$$\frac{4\pi Q}{A} = \frac{V_1 - V_2}{d}, \therefore C = \frac{Q}{V_1 - V_2} = \frac{A}{4\pi d}.$$

This could have been calculated in still another way.

Since

$$R = \frac{4\pi Q}{A},$$

$$V = -\int R dx = -\frac{4\pi Q}{A}x + C_1.$$

For

$$x = 0, V = V_1; \therefore C_1 = V_1.$$

$$V = V_1 - \frac{4\pi Q}{A}x;$$

for

$$x = d, V = V_2; \therefore V_2 = V_1 - \frac{(4\pi Q)}{A}d,$$

or, $V_1 - V_2 = \frac{4\pi Qd}{A}; \therefore C = \frac{Q}{V_1 - V_2} = \frac{A}{4\pi d}, Q.E.D.$

If the plates are separated by uniform insulation of specific inductive capacity, K , the capacity is $\frac{KA}{4\pi d}$ cm., or $\frac{KA}{4\pi d \cdot 9 \cdot 10^{11}}$ farads.

If the dielectric consists of several layers of different specific inductive capacities then one can consider that the condenser is made up of a number of condensers in series and the capacity of each is:

$$C_1 = \frac{K_1 A}{4\pi d_1}, \text{ etc.}$$

The total capacity is obtained from the well-known relation:

$$\frac{1}{C} = \frac{1}{C_1} + \frac{1}{C_2} + \dots, \text{ or,}$$

$$C = \frac{1}{\frac{1}{C_1} + \frac{1}{C_2} + \dots} = \frac{1}{\frac{4\pi d_1}{K_1 A} + \frac{4\pi d_2}{K_2 A} + \dots} = \frac{A}{4\pi \frac{d_1}{K_1} + \frac{d_2}{K_2} + \dots}, \text{ etc.}$$

All these formulæ are approximate, however, since no allowance has been made for the effect of the edges, but the plates were assumed to be infinite.

Concentric Cylinders.—LAPLACE'S equation can again be used if it is assumed that there are no charges between the cylinders. Moreover since we are dealing with cylinders, it is best to put LAPLACE'S equation in cylindrical coördinates. Thus we have:

$$\frac{d^2 V}{dr^2} + \frac{1}{r} \frac{dV}{dr} = 0 \tag{1}$$

let $y = \frac{dV}{dr}$, then (1) becomes $\frac{dy}{dr} + \frac{1}{r} y = 0$.

The solution of this equation is

$$y = A\epsilon^{-\int \frac{dr}{r}} = \frac{A}{\epsilon^{\log r}} = \frac{A}{r}$$

$$\therefore \frac{dV}{dr} = \frac{A}{r}, \text{ and } V = A \log r + B.$$

To determine the integration constants,

let $V = V_1$, $r = r_1$ (Fig. 100)

and $V = V_2$, $r = r_2$.

Then, $V_1 = A \log (r_1) + B$,

and $V_2 = A \log (r_2) + B$.

$$\therefore V_1 - V_2 = A (\log r_1 - \log r_2) = A \log \left(\frac{r_1}{r_2} \right), \therefore A = \frac{V_1 - V_2}{\log \left(\frac{r_1}{r_2} \right)}$$

and,

$$V = \frac{V_1 - V_2}{\log \left(\frac{r_1}{r_2} \right)} \log r + B.$$

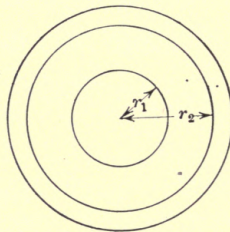

FIG. 100.

The potential gradient or the intensity of the electrostatic field is:

$$G = - \frac{dV}{dr} = \frac{V_1 - V_2}{\log \left(\frac{r_1}{r_2} \right)} \left(\frac{1}{r} \right) = R = \frac{4\pi Q_1 l}{2\pi r l} = \frac{2Q_1}{r} \quad (2)$$

where Q_1 = charge per unit length of conductor, and l = length of conductor.

$$\therefore C = \frac{Q_1}{V_1 - V_2} = \frac{1}{2 \log \left(\frac{r_1}{r_2} \right)} \text{ per centimeter length of conductor.}$$

The potential gradient is the greatest at the surface of the inner conductor, where it is:

$$G_1 = \frac{1}{r_1} \cdot \frac{V_1 - V_2}{\log \left(\frac{r_1}{r_2} \right)}$$

Graded insulation between the conductors.

In order that G may be constant at all points of the dielectric it is evident that the specific inductive capacity must be the highest at the inner conductor, and be inversely proportional to the distance from the inner conductor.

Let the specific inductive capacity be expressed by the following formula:

$$K = \frac{a}{r}, \text{ where } a \text{ is a constant.}$$

With a charge Q on the inner conductor, the flux per centimeter length is $4\pi Q$, thus the force on unit charge is:

$$\frac{4\pi Q}{K2\pi r} = \frac{2Q}{Kr}$$

$$V = - \int \frac{2Q}{Kr} dr = - \int \frac{2Qr}{ar} dr = - \int \frac{2Q}{a} dr = - \frac{2Qr}{a} + A.$$

$$G = - \frac{dV}{dr} = \frac{2Q}{a} = \text{constant.}$$

The same result could have been obtained directly from (2), which, in the general case when $K1$, becomes:

$$R = \frac{4\pi Q}{K2\pi r} = \frac{2Q}{Kr}$$

$$K = \frac{a}{r}$$

Substituting

$$R = \frac{2Q}{\left(\frac{a}{r}\right)r} = \text{constant, } Q.E.D.$$

CHAPTER XIX

CYLINDRICAL CONDUCTORS

Line Charge.—Assume that the conductor which is perpendicular to the page is infinitely long and its diameter so small that it may be considered as line, and let the charge per unit length be Q .

The electric field is then represented by radial lines in planes parallel to the page or, which is the same, at right angles to the axis of the conductor.

The intensity of the field at a point P , Fig. 101, is obviously:

$$R = \frac{4\pi Q}{2\pi r_1} = \frac{2Q}{r_1}.$$

And the difference in potential between two points P_1 and P is:

$$\begin{aligned} V_p - V_{p_1} &= - \int_{h_1}^{r_1} R dr = - \int_{h_1}^{r_1} \frac{2Q}{r} dr \\ &= - 2Q [\log r_1 - \log h_1] = 2Q \log \left(\frac{h_1}{r_1} \right) \quad (1) \end{aligned}$$

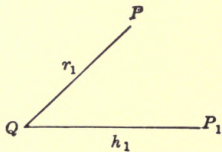

FIG. 101.

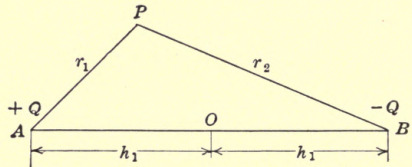

FIG. 102.

Two equal but opposite line charges separated by a distance $2h_1$: Let A and B (Fig. 102) be the locations of the line charges. The difference in potential between O —midways between the charges—and P , due to the charge on A alone, is and has been shown:

$$V_p - V_o = 2Q \log \frac{h_1}{r_1} \quad (2)$$

The difference of potential between o and P due to the line charge $-Q$ on B is obviously,

$$V_p - V_o = - 2Q \log \frac{h_1}{r_2} \quad (3)$$

Thus the difference of potential between O and P due to both line charges is:

$$V_p - V_o = \left(2Q \log \frac{h_1}{r_1} - \log \frac{h_1}{r_2}\right) = 2Q \log \frac{r_2}{r_1} \quad (4)$$

Referring to equation (2) or (3), if P lies midway between A and B , so that $r_1 = r_2 = h_1$, then:

$$V_p - V_o = 0,$$

thus as long as the charges are equal and opposite, the potential at O is zero, which would, of course, have been concluded without proof.

$$V = 2Q \log \frac{r_2}{r_1} \quad (5)$$

where V is the potential of P due to the charges on both lines. From (5), follows

$$\frac{r_2}{r_1} = \frac{V}{\epsilon^{2Q}} = \alpha = \text{a constant} \quad (6)$$

for all surfaces of potential V .

Equation (6) represents a circle, defined by the following relation:

$$\overline{OA} \times \overline{OB} = R^2 \quad (7)$$

referring to Fig. 103, where O is the center of the circle, A and B Fig. 103) are called the inverse points, and O' the center of inversion.

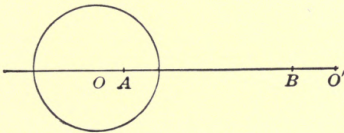

FIG. 103.

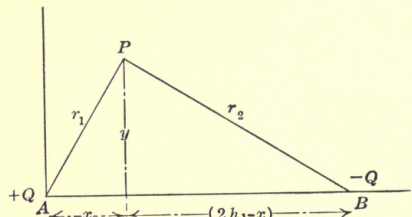

FIG. 104.

To prove that equation (6) represents a circle refer to Fig. 104.

$$\begin{aligned} r_1^2 &= x^2 + y^2. \\ r_2^2 &= (2h_1 - x)^2 + y^2 = x^2 + y^2 + 4h_1^2 - 4h_1x, \\ \therefore \frac{r_2^2}{r_1^2} &= C^2 = \frac{x^2 + y^2 + 4h_1^2 - 4h_1x}{x^2 + y^2}, \end{aligned}$$

or,

$$x^2(1 - C^2) + y^2(1 - C^2) - 4h_1x + 4h_1^2 = 0,$$

which is the familiar equation of a circle having a radius of

$$R = \frac{2h_1C}{1 - C^2},$$

and its center at a point whose coördinates are:

$$\left. \begin{aligned} x_1 &= \frac{2h_1}{1 - C^2}, \\ y_1 &= 0, \end{aligned} \right\} \text{from } A;$$

$$\left. \begin{aligned} x_1 &= -\left(2h_1 - \frac{2h_1}{1 - C^2}\right), \\ y_1 &= 0, \end{aligned} \right\} \text{from } B.$$

$$\therefore \overline{OA} \times \overline{OB} = \frac{4h_1C^2}{(1 - C^2)^2} = R^2;$$

thus, equations (6) and (7) are proved.

The ratio, $\frac{r_2}{r_1}$, can be expressed by a simple equation involving h , the distance of the center from the neutral plane, and the radius, R .

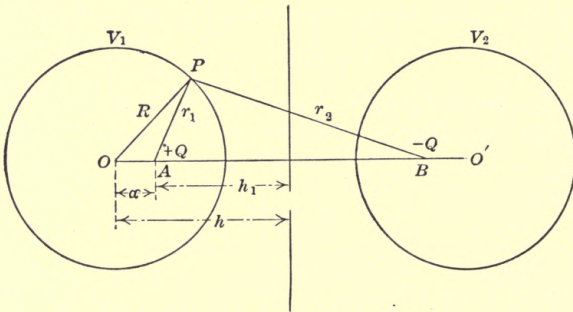

FIG. 105.

Referring to Fig. 105.

$$R^2 = \overline{OA} \times \overline{OB} = (h - h_1)(h + h_1) = h^2 - h_1^2,$$

or,
$$h_1 = \sqrt{h^2 - R^2} \quad (8)$$

But triangles OPB and OPA are similar, since

$$\overline{OP}^2 = \overline{OA} \times \overline{OB};$$

$$\therefore \frac{r_2}{\overline{OP}} = \frac{r_1}{\overline{OA}},$$

$$\frac{r_2}{r_1} = \frac{\overline{OP}}{\overline{OA}} = \frac{R}{h - h_1} = \frac{R}{\alpha} \quad (9)$$

Substituting (8) in (9),

$$\frac{r_2}{r_1} = \frac{R}{h - \sqrt{h^2 - R^2}} = \frac{R(h + \sqrt{h^2 - R^2})}{R^2} = \frac{h + \sqrt{h^2 - R^2}}{R} \quad (10)$$

We can then determine the potential of a circle, or, which is equivalent in this case, a cylinder, whose center is h cm. from the neutral plane and whose radius is R , as

$$V_1 = 2Q \log \frac{r_2}{r_1} = 2Q \log \frac{h + \sqrt{h^2 - R^2}}{R} \quad (11a)$$

Similarly the potential at a circle around the negative charge is:

$$V_2 = -2Q \log \frac{h + \sqrt{h^2 - R^2}}{R} \quad (12a)$$

$$\therefore V = V_1 - V_2,$$

that is, the potential difference between the two cylinders is:

$$V = 4Q \log \frac{h + \sqrt{h^2 - R^2}}{R} \quad (13a)$$

For the sake of convenience, will be added other expressions for V_1 , V_2 and V , involving h_1 , and R instead of h and R .

$$\text{From (8),} \quad h^2 = R^2 + h_1^2,$$

which, substituted, gives

$$V_1 = 2Q \log \frac{h_1 + \sqrt{h_1^2 + R^2}}{R} \quad (11b)$$

$$V_2 = -2Q \log \frac{h_1 + \sqrt{h_1^2 + R^2}}{R} \quad (12b)$$

and,

$$V = 4Q \log \frac{h_1 + \sqrt{h_1^2 + R^2}}{R} \quad (13b)$$

It is now evident how we can go from line charges to charges on actual conductors. It has been proven that the equipotential surfaces around the line charges are cylinders and hence if circular cylinders be substituted for the circles, the distribution of the field is not affected.

The capacity per centimeter length of two such metal cylinders (that is, of the double conductor) is:

$$C = \frac{Q}{V} = \frac{K}{4 \log \frac{h + \sqrt{h^2 - R^2}}{R}} \text{ cm.} \quad (14)$$

or,
$$C_{farad} = \frac{K}{9 \times 10^{11} 4 \log \frac{h + \sqrt{h^2 - R^2}}{R}} \text{ farads} \quad (15)$$

or, $C_{m-f.}$ per 1000 ft., of circuit (double conductor)

$$= \frac{0.00367K}{\log_{10} \frac{h + \sqrt{h^2 - R^2}}{R}} \text{ m-f.} \quad (16)$$

*where \log_{10} means the ordinary logarithm—not the natural logarithm— h is half the distance between conductors, and K the specific inductive capacity.

If E is the effective value of the alternating-current line voltage, then the charging current per 1000 ft. of double conductor is readily proven to be:

$$I_c = 2\pi_f \frac{C_{m-f.}}{10^6} E.$$

The capacity to neutral is obtained directly from (11a) and is:

$$C = \frac{1}{2 \log \frac{h + \sqrt{h^2 - R^2}}{R}}.$$

It is thus seen that the capacity to neutral is twice as great as that between the lines.

This results, of course, in the same charging current as in the first case, since in this case the voltage is $\frac{E}{2}$. Thus the capacity of 1000 ft. of one wire to neutral or ground is:

$$C_{m-f.} = \frac{0.00735K}{\log_{10} \frac{h + \sqrt{h^2 - R^2}}{R}} \text{ m-f. per 1000 ft. of transmission.}$$

Two Parallel Cylindrical Conductors of Different Diameters but Equal and Opposite Charges.—Since $\overline{OA} \times \overline{OB} = R_1^2$ and $\overline{O'B} \times \overline{O'A} = R_2^2$, we have

$$\alpha(\alpha + 2h_1) = R_1^2, \text{ or } \alpha = -h_1 + \sqrt{h_1^2 + R_1^2} \quad (1)$$

and

$$\beta(\beta + 2h_1) = R_2^2, \text{ or } \beta = -h_1 + \sqrt{h_1^2 + R_2^2} \quad (2)$$

$$V_1 = 2Q \log \frac{r_2}{r_1} = 2Q \log \frac{R_1}{\alpha},$$

and

$$V_2 = -2Q \log \frac{r'_2}{r'_1} = -2Q \log \frac{R_2}{\beta}.$$

$$\therefore V_1 - V_2 = 2Q \log \frac{R_1 R_2}{\alpha \beta} \quad (3)$$

Substituting (1) and (2) in (3),

$$V_1 - V_2 = 2Q \log \frac{R_1 R_2}{(-h_1 + \sqrt{h_1^2 + R_1^2})(-h_1 + \sqrt{h_1^2 + R_2^2})}$$

and

$$C = \frac{Q}{V_1 - V_2} = \frac{1}{2 \log \frac{R_1 R_2}{(-h_1 + \sqrt{h_1^2 + R_1^2})(-h_1 + \sqrt{h_1^2 + R_2^2})}}$$

To obtain an expression in terms of h and R , instead of h_1 and R , from Fig. 106 we have:

$$\beta = 2h - 2h_1 - \alpha \tag{4}$$

$$\therefore \beta + 2h_1 = 2h - \alpha \tag{5}$$

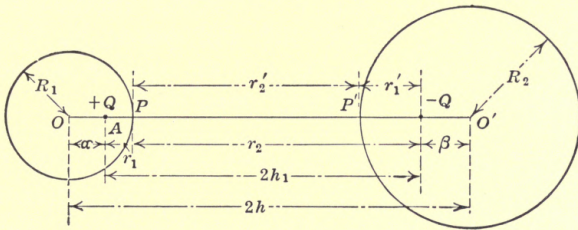

FIG. 106.

Substituting (4) and (5) in (2),

$$(2h - 2h_1 - \alpha)(2h - \alpha) \tag{6}$$

Solving (1) for $2h_1$ and substituting it in (6),

$$(2h - \frac{R_1^2 - \alpha^2}{\alpha} - \alpha)(2h - \alpha) = R_2^2,$$

or,

$$2h\alpha^2 + (R_2^2 - R_1^2 - 4h^2)\alpha + 2hR_1^2 = 0,$$

or,

$$\alpha = \frac{(R_1^2 - R_2^2 + 4h^2) - \sqrt{(R_1^2 - R_2^2 + 4h^2)^2 - 16h^2R_1^2}}{4h}$$

$$= \frac{R_1^2 - R_2^2 + 4h^2 - \sqrt{(R_1^2 - R_2^2)^2 - 8h^2(R_1^2 + R_2^2) + 16h^4}}{4h},$$

where the sign in front of the radical is minus—not plus, because $\alpha = 0$ when $R_1 = 0$. Similarly,

$$\beta = \frac{(R_2^2 - R_1^2 + 4h^2) - \sqrt{(R_1^2 - R_2^2)^2 - 8h^2(R_1^2 + R_2^2) + 16h^4}}{4h}$$

$$\therefore C = \frac{1}{2 \log \left(\frac{R_1 R_2}{\alpha \beta} \right)} =$$

$$2 \log \frac{1}{4h^2 - (R_1^2 + R_2^2) - \sqrt{16h^4 - 8h^2(R_1^2 + R_2^2) + (R_1^2 - R_2^2)}}$$

which becomes:

$$C = \frac{1}{4 \log \frac{h + \sqrt{h^2 - R^2}}{R}}$$

if R is substituted for both R_1 and R_2 , a result obtained before.

Construction of Equipotential Surfaces around a Cylindrical Conductor, Charged to a Certain Potential, V .—Let the distance between the center of the conductor, Fig. 107, and ground be h , and the distance of the equivalent line charge above ground be h_1 .

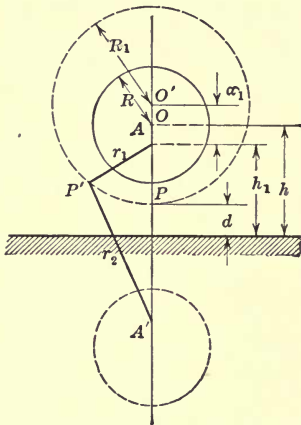

FIG. 107.

Since the ground is an equipotential surface, it is evident that the problem will in no way be affected, if a second conductor with a charge $-Q$ be placed equidistant below the ground surface, and the equipotential surfaces around A be considered as due to a positive charge, Q at A , and an equal but opposite ("image") charge $-Q$, at the inverse point A' .

Suppose that it is desired to draw the equipotential surface through a point P , distant d from the ground.

The first step is to locate the equivalent line charge in the original conductor of radius R and distance h from ground. We have,

$$\begin{aligned} h_1^2 &= h^2 - R^2, \\ \therefore h_1 &= \sqrt{h^2 - R^2} \end{aligned} \quad (1)$$

To find the radius of a circle whose center is α_1 from A , the location of the equivalent line charge, we have,

$$\alpha_1(2h_1 + \alpha_1) = R_1^2 \quad (2)$$

But from the figure we have,

$$h_1 + \alpha_1 = R_1 + d \quad (3)$$

$$\therefore \alpha_1 = R_1 + d - h_1. \quad (4)$$

Substituting (4) in (2),

$$(R_1 + d - h_1)(2h_1 + R_1 + d - h_1) = R_1^2 = (R_1 + d - h_1)(R_1 + d + h_1),$$

$$\therefore R_1 = \frac{h_1^2 - d^2}{2d} \quad (5)$$

The potential of the circle of radius R_1 , which goes through the point, P , is:

$$V_1 = 2Q \log \frac{r_2}{r_1} = 2Q \log \frac{h_1 + \sqrt{h_1^2 + R_1^2}}{R_1}.$$

But V , the potential of the conductor, is:

$$V = 2Q \log \frac{h_1 + \sqrt{h_1^2 + R^2}}{R} \log \frac{h_1 + \sqrt{h_1^2 + R_1^2}}{R_1} \quad (6)$$

$$\therefore \frac{V_1}{V} = \frac{1}{\log \frac{h_1 + \sqrt{h_1^2 + R^2}}{R}}.$$

Knowing the radius from (5), and the center is $R_1 + d$ above ground, the equipotential surface through P can be drawn, and the potential of that surface is given by (6).

Potential of a Cylinder due to External Charges.—In order to determine the potential due to a number of charged cylindrical conductors, it is necessary to calculate the potential of one cylinder due to charges on other cylinders placed in the vicinity.

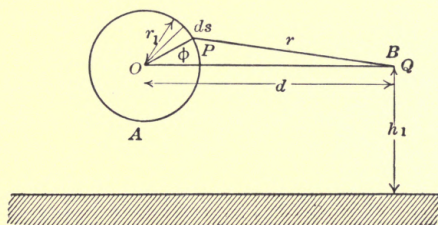

FIG. 108.

Consider a line charge Q at B in Fig. 108 and determine the average potential due to Q on a non-conductive cylinder A . The potential at P is, as has been shown:

$$V = 2Q \log \frac{h_1}{r},$$

but from the triangle OPB ,

$$r^2 = d^2 - 2dr_1 \cos \phi + r_1^2 = d^2 \left[1 - \frac{2r_1}{d} \cos \phi + \frac{r_1^2}{d^2} \right],$$

or,

$$r = d \sqrt{k^2 + 1 - 2k \cos \phi},$$

where

$$k = \frac{r_1}{d}.$$

Thus the average potential of A is:

$$\begin{aligned} V_A &= \frac{1}{2\pi} \int_0^{2\pi} [2Q \log h_1 - 2Q \log d \sqrt{1 + k^2 - 2k \cos \phi}] d\phi \\ &= \frac{4\pi Q \log h_1}{2\pi} - \frac{2Q}{2\pi} \int_0^{2\pi} \log dd\phi - \frac{Q}{2\pi} \\ &\quad \int_0^{2\pi} \log (1 + k^2 - 2k \cos \phi) d\phi \\ &= 2Q \log h_1 - 2Q \log d - \frac{Q}{2\pi} \int_0^{2\pi} \log (a - b \cos \phi) d\phi, \end{aligned}$$

where

$$a = 1 + k^2,$$

and,

$$b = 2k.$$

Evaluating the definite integral (see PIERCE'S "Table of Integrals") we find that the last term is zero.

Thus,

$$V_A = 2Q(\log h_1 - \log d) = 2Q \log \frac{h_1}{d} \quad (1)$$

Thus, the average potential is independent upon the radius of the conductor.

But equation (1) has been shown previously to be the potential at a point distant d from a line charge distant h_1 above ground.

Thus to determine the potential of a cylindrical conductor A , due to a line charge at B distant d , the diameter of the conductor does not enter as long as, with metallic conductors, the field can be assumed not disturbed by the conductor.

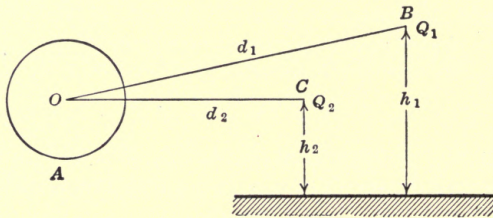

FIG. 109.

Referring to Fig. 109,

The potential of A due to B is:

$$V_1 = 2Q_1 \log \frac{h_1}{d_1}.$$

The potential of A due to C is:

$$V_2 = 2Q_2 \log \frac{h_2}{d_2}.$$

$$\therefore V = V_1 + V_2 = 2Q_1 \log \frac{h_1}{d_1} + 2Q_2 \log \frac{h_2}{d_2}.$$

Lines of Force between Parallel Cylinders.—Let $s-s$ (Fig. 110) be a part of a line of force, and $N-N$ a line at right angles to it. Thus the projection of G_1 on the normal is $G_1 \cos \alpha$,

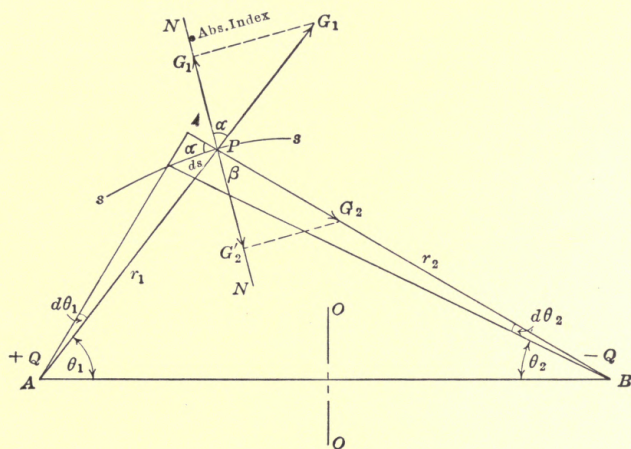

FIG. 110.

where G_1 is the intensity at P due to the line charge at A . Similarly the projection of G_2 on the normal is $G_2 \cos \beta$. The sum of the projections must be zero, since $N-N$ is perpendicular to the line of force.

$$\therefore G_1 \cos \alpha + G_2 \cos \beta = 0 \quad (1)$$

But

$$\cos \alpha = r_1 \frac{d\theta_1}{ds},$$

and

$$G_1 = \frac{4\pi Q}{2\pi r_1} = \frac{2Q}{r_1}.$$

$$\therefore G_1 \cos \alpha = \frac{2Q}{r_1} \frac{r_1 d\theta_1}{ds} = 2Q \frac{d\theta_1}{ds}.$$

Similarly,

$$G_2 \cos \beta = -2Q \left(\frac{d\theta_2}{ds} \right).$$

Substituting in (1),

$$d\theta_1 + d\theta_2 = 0$$

or

$$\theta_1 + \theta_2 = \text{constant.}$$

This equation represents a family of circles through A and B , with center on the line $O-O$.

Construction of Lines of Force.—Referring to Fig. 111, as P is in the center line,

$$G_3 = G_1 \cos \theta_1 + G_2 \cos \theta_1 = 2 \left[\frac{2Q}{r_1} \cdot \frac{h_1}{r_1} \right] = \frac{4Qh_1}{r_1^2} = \frac{4Qh_1}{h_1^2 + X^2}$$

or,

$$x = h_1 \sqrt{\frac{4Q}{G_3 h_1} - 1} \quad (1)$$

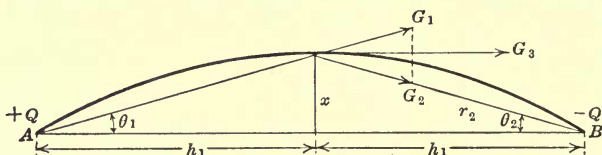

FIG. 111.

Knowing the values of x and the fixed points, A and B , the lines of force, being circles, can be readily constructed.

Problem.—Draw equipotential surfaces around a line charge placed 10 cm. above the neutral plane, when the charge is 1 electro-static unit per centimeter of conductor.

Find the radius of the conductor containing the line charge whose potential is 2000 volts. Draw surfaces corresponding to 400, 800, 1200 and 1600 volts.

Draw lines of force whose intensities at the neutral plane are 120, 110, 100, 90 and 80 volts per centimeter.

Solutions.—

First.—Radius of conductor: Since 2000 volts corresponds to 6.67 electro-static units, we have:

$$6.67 = 2Q \log \frac{h_1 + \sqrt{h_1^2 + R^2}}{R} = 2 \log \frac{10 + \sqrt{100 + R^2}}{R}$$

$$\therefore \log_{10} \frac{10 + \sqrt{100 + R^2}}{R} = 0.434 \times 3.3 = 1.445.$$

$$\therefore \frac{10 + \sqrt{100 + R^2}}{R} = 28.05 \quad \therefore R = 0.72 \text{ cm.}$$

By a similar process the radii corresponding to 1600, 1200, 800 and 400 volts are found.

These being calculated, the corresponding values of h , the distances from the neutral plane, are found by the relation $h = \sqrt{h_1^2 + R^2}$.

Second.—To find the intersection between the neutral plane and the line of force of intensity 100 volts per centimeter or 0.333 electro-static units, we have:

$$x = h_1 \sqrt{\frac{4Q}{G_3 h_1}} - 1 = 10 \sqrt{\frac{4}{0.333 \times 10}} - 1 = 10 \times 0.447 = 4.47 \text{ cm.}$$

Capacity of Two Cylindrical Conductors, when the Effect of the Proximity of the Earth is Considered.—Consider, for the sake of simplicity, the case of two cylinders of equal radii, and charges Q and Q_1 respectively.

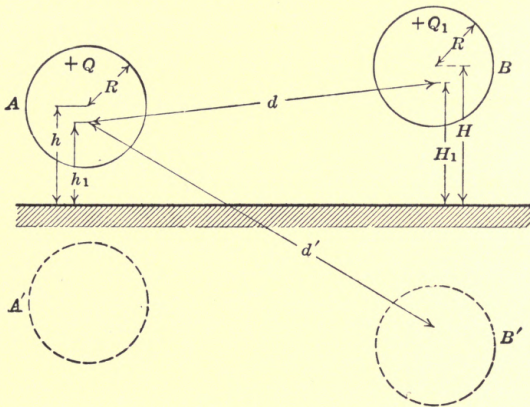

FIG. 112.

Referring to Fig. 112, it has been shown that the potential of A due to its own charge, Q , and the charge on its image, A' is:

$$V_1 = 2Q \log \frac{h + \sqrt{h^2 - R^2}}{R} \tag{1}$$

It has also been shown that the potential of A due to the Q_1 , on conductor B is:

$$V_2 = 2Q_1 \log \frac{H_1}{d} \tag{2}$$

Similarly, the potential of A due to the image of B is:

$$V_3 = 2Q_1 \log \frac{H_1}{d'} \tag{3}$$

Thus the total effect of conductor B on A is:

$$V_2 + V_3 = 2Q_1 \log \frac{d'}{d} \quad (4)$$

And the resultant potential of A is:

$$V_A = V_1 + V_2 + V_3 = 2Q \log \frac{h + \sqrt{h^2 - R^2}}{R} + 2Q_1 \log \frac{d'}{d} \quad (5)$$

Similarly,

$$V_B = 2Q_1 \log \frac{H + \sqrt{H^2 - R^2}}{R} + 2Q \log \frac{d'}{d} \quad (6)$$

Special Cases.—Two wires in parallel at same distance from ground.

Thus $h = H$, $Q = Q_1$. $\therefore V_A = V_B = V$.

$$\therefore V = 2Q \log \left[\frac{d'}{d} \cdot \frac{h + \sqrt{h^2 - R^2}}{R} \right]$$

Thus the capacity per centimeter of each wire is:

$$C_1 = \frac{Q}{V} = \frac{1}{2 \log \left[\frac{d'}{d} \cdot \frac{h + \sqrt{h^2 - R^2}}{R} \right]} \quad (7)$$

and the capacity of the two wires taken together, is:

$$C_2 = \frac{1}{\log \left[\frac{d'}{d} \cdot \frac{h + \sqrt{h^2 - R^2}}{R} \right]} \quad (8)$$

In the case of a transmission line, h is large compared with R , and d' is approximately $2h$.

$$\therefore C_1 \cong \frac{1}{2 \log \left(\frac{2h}{d} \cdot \frac{2h}{R} \right)} = \frac{1}{2 \left[\log \frac{2h}{d} + \log \frac{2h}{R} \right]} \quad (9)$$

It has been shown that the capacity of a single wire to neutral is:

$$C = \frac{1}{2 \log \frac{h + \sqrt{h^2 - R^2}}{R}} \cong \frac{1}{2 \log \frac{2h}{R}} \text{ approximately.} \quad (10)$$

Thus the proximity of the other wire has reduced the capacity of each wire, so that the combined capacity of the two in parallel is usually not more than 25 to 30 per cent. greater than that of a single wire.

As an instance, let $R = 0.5$ cm., $h = 1,000$ cm., and $d = 20$ cm.

$$\therefore C_1 = \frac{1}{2 \left(\log \frac{2000}{20} + \log \frac{2000}{0.5} \right)} = 0.0388 \text{ cm. per centimeter;}$$

$$\therefore 2C_1 = 0.0776 \text{ cm. per centimeter}$$

and the capacity of one single wire alone is

$$C = \frac{1}{2 \log \frac{2000}{0.5}} = 0.0603 \text{ cm. per centimeter.}$$

The capacity of the double wire is thus only 28.7 per cent. greater than that of a single wire.

Second.—Assume now that wire A' forms the return for A , so that the charge on A is Q and that on B is $-Q$.

From equation (5),

$$\begin{aligned} V_A &= 2Q \log \frac{h + \sqrt{h^2 - R^2}}{R} - 2Q \log \frac{d'}{d} \\ &\equiv 2Q \log \left(\frac{2h}{R} \cdot \frac{d}{d'} \right) \text{ approximately;} \end{aligned}$$

and

$$V_B = 2Q \log \left(\frac{d'}{d} \cdot \frac{R}{2h} \right) \text{ approximately.}$$

$$\therefore V_A - V_B = 2Q \log \left(\frac{2h}{R} \cdot \frac{d}{d'} \cdot \frac{d}{d'} \cdot \frac{2h}{R} \right) = 4Q \log \frac{2hd}{Rd'}$$

$$\therefore C_1 = \frac{1}{4 \log \frac{2hd}{Rd'}} \quad (11)$$

If the effect of the ground has been neglected, then, as has been shown, the capacity between the two wires would have been approximately:

$$C = \frac{1}{4 \log \frac{d}{R}} \quad (12)$$

Comparing equations (11) and (12), it is evident that since $\frac{2h}{d'}$ is always smaller, but usually only very little smaller than unity, C_1 is slightly greater than C .

The proximity of the ground has thus slightly increased the capacity between wires. In transmission lines, the increase amounts usually to less than 1 or 2 per cent.

CHAPTER XX

MUTUAL AND SELF-INDUCTION OF ELECTRO-STATIC CHARGES OR FLUXES—MAXWELL'S COEFFICIENTS

If among a number of conductors say No. 1, No. 2, etc., a particular one, say No. 1, is given a charge q_1 , so that its potential is V_1 , and if all other conductors are connected to ground, that is, are at zero potential, then,

$$q_1 = K_{1.1}V_1,$$

where $K_{1.1}$ (with its two indices) is called the coefficient of self-induction of electrostatic charge, and is, as seen, the capacity of No. 1 due to its own charge q_1 , when all other conductors are at zero potential.

Obviously while the potential of the other conductors is zero, each has a certain part of the induced negative charge corresponding to q_1 on No. 1.

The charge on No. 2, for instance, is of course proportional to the potential of No. 1 and is written:

$$q_2 = K_{2.1}V_1.$$

Similarly,

$$q_3 = K_{3.1}V_1, \quad q_4 = K_{4.1}V_1, \text{ etc.}$$

$K_{2.1}$, $K_{3.1}$, etc., are called the coefficients of mutual induction. Since V_1 is positive, q_2 must be negative, therefore, $K_{2.1}$, or in general, K with two different indices, is always negative, while K with same indices is positive.

If instead of grounding all of the conductors except No. 1, we now ground all but No. 2, and this is given a potential V_2 , we get, by a similar reasoning,

$q_2 = K_{2.2}V_2$, $q_3 = K_{3.2}V_2$, $q_4 = K_{4.2}V_2$, and, $q_1 = K_{1.2}V_2$. Superimposing these conditions, it is readily concluded, that, if at any time the potential of No. 1 is V_1 , that of No. 2 is V_2 , etc.

The following relation obtains, if Q_1, Q_2, Q_3 , etc., are the total charges on No. 1, No. 2, etc.:

$$\left. \begin{aligned} Q_1 &= K_{1.1}V_1 + K_{1.2}V_2 + K_{1.3}V_3 + \text{''''''} \\ Q_2 &= K_{2.1}V_1 + K_{2.2}V_2 + K_{2.3}V_3 + \text{''''''} \\ Q_3 &= K_{3.1}V_1 + K_{3.2}V_2 + K_{3.3}V_3 + \text{''''''} \end{aligned} \right\} \quad (1)$$

A little consideration will show that $K_{1.2} = K_{2.1}$, etc.

The applications of these relations will be illustrated in the case of the two similar overhead wires (Fig. 113). The immediate problem being to determine the values of $K_{1.1}, K_{2.2}$ and $K_{1.2}$.

On account of symmetry, $K_{1.1} = K_{2.2}$, thus we have really only two unknown quantities, namely, $K_{1.1}$ and $K_{1.2}$.

To determine them, give two equal charges $+Q$ to the conductors, then $V_1 = V_2$.

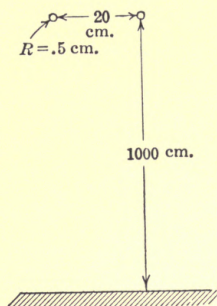

FIG. 113.

From (1), $Q_i = K_{1.1}V_1 + K_{1.2}V_2 = V_1(K_{1.1} + K_{1.2})$,

$$\therefore K_{1.1} + K_{1.2} = \frac{Q_1}{V_1} = C = \frac{1}{2 \log \left(\frac{d'}{d} \cdot \frac{2h}{R} \right)} \quad (2)$$

[See (9) in the previous article.]

Now give one conductor a charge $+Q$ and the other a charge $-Q$, so that the potential of No. 1 is V_1 and that of No. 2 is $-V_1$, then from (1), $Q_1 = V_1 (K_{1.1} - K_{1.2})$,

$$\therefore K_{1.1} - K_{1.2} = \frac{Q_1}{V_1} = C' = \frac{1}{2 \log \left(\frac{d'}{d} \cdot \frac{2h}{R} \right)} \quad (3)$$

[See (11) in the previous article.]

From these equations it follows that:

$$K_{1.1} = \frac{\log \left(\frac{2h}{R} \right)}{2 \log \left(\frac{d'}{d} \cdot \frac{2h}{R} \right) \log \left(\frac{d'}{d} \cdot \frac{2h}{R} \right)} = \frac{C + C'}{2} \quad (4)$$

$$K_{1.2} = - \frac{\log \left(\frac{d'}{d} \right)}{2 \log \left(\frac{d'}{d} \cdot \frac{2h}{R} \right) \log \left(\frac{d'}{d} \cdot \frac{2h}{R} \right)} = \frac{C - C'}{2} \quad (5)$$

and,

$$\frac{K_{1.1}}{K_{1.2}} = - \frac{\log \frac{2h}{R}}{\log \frac{d'}{d}} = \frac{C + C'}{C - C'} \quad (6)$$

Numerical application, Fig. 113:

$$\begin{aligned} \text{Let } R &= 0.5 \text{ cm.} \\ h &= 1000 \text{ cm.} \\ d &= 20 \text{ cm.} \\ \therefore d' &\cong 2000 \text{ cm.} \end{aligned}$$

$$\begin{aligned} \therefore \frac{2h}{R} &= 4000, \\ \frac{d'}{d} &= 100, \end{aligned}$$

and,

$$\begin{aligned} \frac{d}{d'} &\cong 0.01. \\ \therefore C &= \frac{1}{2 \log 400,000} = 0.0388, \\ C' &= \frac{1}{2 \log 40} = 0.1352. \end{aligned}$$

$$\begin{aligned} \therefore K_{1.1} &= 0.087, \\ K_{1.2} &= -0.0482, \\ \frac{K_{1.1}}{K_{1.2}} &= -1.806. \end{aligned}$$

Discussion.—To show the application of these coefficients, the following problems will be considered.

A. Compare the capacities between a wire and ground, (a) when the wire is alone; (b) when an adjacent wire is grounded.

B. Compare the charging currents for the same applied voltage between the two conductors when the two wires are insulated, and when one is grounded. In the latter case, give the relative proportions of the current in the grounded wire and in the ground itself.

The numerical case will be: $R = 0.5$ cm.;

$h = 1000$ cm.;

and,

$d = 20$ cm.

The problems will be best solved by the use of the MAXWELL'S equations, viz.

$$Q_1 = K_{1.1}V_1 + K_{1.2}V_2 + K_{1.3}V_3,$$

$$Q_2 = K_{2.1}V_1 + K_{2.2}V_2 + K_{2.3}V_3,$$

and,

$$Q_3 = K_{3.1}V_1 + K_{3.2}V_2 + K_{3.3}V_3.$$

In these equations, index 1 refers to conductor No. 1, index 2 to No. 2, and index 3 to the ground.

Since the potential of No. 3 is zero and since we assume two similar and similarly placed conductors,

$$V_3 = 0, K_{1.1} = K_{2.2} \text{ and } K_{1.3} = K_{2.3}.$$

$$\therefore Q_1 = K_{1.1}V_1 + K_{1.2}V_2 \tag{7}$$

$$Q_2 = K_{1.2}V_1 + K_{1.1}V_2 \tag{8}$$

and
$$Q_3 = K_{1.3}V_1 + K_{1.3}V_2 \tag{9}$$

Case A.—(a) It has been shown that with a single conductor suspended above ground, the capacity is:

$$C = \frac{1}{2 \log \frac{2h}{R}} = 0.0601 \text{ cm. per cm.} \tag{10}$$

Thus if V is its potential the charging current is:

$$r_1 = 0.0601 \frac{dV}{dt}$$

(b) since No. 2 is grounded, $V_2 = 0$.

Thus from (7), $Q_1 = K_{1.1}V_1 \therefore$ capacity = $K_{1.1} = 0.087$, and

$$r_1 = 0.087 \frac{dV}{dt}$$

The capacity of wire No. 1 is increased 45 per cent. by the proximity of the grounded adjacent wire No. 2.

Case B.—Under normal conditions,

$$Q_2 = -Q_1 \text{ and } K_{1.1} = K_{2.2},$$

$$\therefore Q_1 = K_{1.1}V_1 + K_{1.2}V_2,$$

$$-Q_1 = K_{2.1}V_1 + K_{1.1}V_2$$

$$\begin{aligned} \therefore 2Q_1 &= V_1(K_{1.1} - K_{1.2}) + V_2(K_{1.2} - K_{1.1}) \\ &= (V_1 - V_2)(K_{1.1} - K_{1.2}). \end{aligned}$$

Thus the capacity between the conductors is:

$$C = \frac{K_{1.1} - K_{1.2}}{2} = 0.0676.$$

If $V_1 - V_2 = V$, and if i_1 is the current in conductor No. 1, then

$$i_1 = C \frac{dV}{dt} = \frac{1}{2} (K_{1.1} - K_{1.2}) \frac{dV}{dt} = 0.0676 \frac{dV}{dt}.$$

When No. 2 is grounded, $V_2 = 0$.

$$\therefore Q_1 = K_{1.1}V_1 = K_{1.1}V, \text{ thus the capacity, } C' = K_{1.1},$$

$$\therefore i_1 = K_{1.1} \frac{dV}{dt} = 0.087 \frac{dV}{dt},$$

$$\therefore \frac{i'_1}{i_1} = \frac{2K_{1.1}}{K_{1.1} - K_{1.2}} = 1.285.$$

The charging current in conductor No. 1 is increased 28.5 per cent. by the proximity of the adjacent grounded wire.

The charge in conductor No. 2 is:

$$Q_2 = K_{2.1}V_1 + K_{2.2} V_2 = K_{1.2}V, \text{ since } V_2 = 0.$$

But $K_{1.2} = -0.135 + 0.087 = -0.048$

Thus $i_2 = -0.048 \frac{dV}{dt}$

The current carried in the ground is obviously

$$-i_3 = (0.087 - 0.048) \frac{dV}{dt}$$

$$\therefore i_3 = -0.039 \frac{dV}{dt}$$

If the current in No. 1 after grounding No. 2, is taken as 1 amp., then wire No. 1 carries 1 amp., No. 2, 0.554 amp. and the ground, 0.446 amp.

Problem.—Assume three similar horizontal conductors of $R = 0.5$, $h = 1000$ and $d = 20$.

Give the relative values of the charging current between No. 1 and No. 3 if No. 2 is insulated, and if it is grounded. Also give the charging current if No. 2 is removed entirely. Consider the current in the last case to be unity.

CHAPTER XXI

TWO-CONDUCTOR CABLE

Since the conductors as well as the lead covering are of metal, the surfaces of each are equipotential surfaces. In order to simplify the calculations it is desirable to substitute for the sheath and each conductor a system of conductors, *i.e.*, the conductor, and its image, which will give the same distribution of potential.

Consider first the system of Fig. 114 consisting of A , its image A' and the lead sheath. It is necessary to determine the position of the line charges at distance h_1 from the neutral plane, so that the conductor A and the sheath are equipotential surfaces.

From what has been shown previously, it is evident that the following relations exist:

$$h_1^2 = h^2 - r^2, \text{ when considering the conductor;}$$

and

$$h_1^2 = (h + a)^2 - r_1^2, \text{ when considering the sheath.}$$

$$\therefore h = \frac{r_1^2 - r^2 - a^2}{2a} \quad (1)$$

Having determined h from (1),

$$h_1 \text{ is determined, as } h_1 = \sqrt{h^2 - r^2} \quad (2)$$

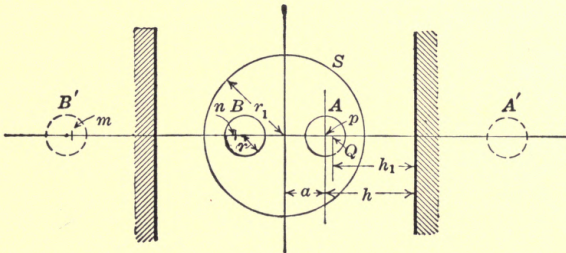

FIG. 114.

Referring to Fig. 114, it is evident that the potential of A is due to its own charge and the charge on its image, and the charges on B and its image.

It is also recollected that the latter potential is: $2Q \log \frac{np}{mp}$,

if we neglect the shortening of the lines of force from m to p in going through conductor B , where \overline{np} is the distance between the line charge in B and the center of A , and $\overline{m\bar{p}}$ is the distance between the line charge in B' and the center of A .

$$\therefore \overline{np} = 2a + h - h_1,$$

$$\text{and } \overline{m\bar{p}} = 2a + h + h_1.$$

$$\begin{aligned} \therefore V_A &= 2Q \log \frac{h + \sqrt{h^2 - r^2}}{r} + 2Q \log \frac{2a + h - h_1}{2a + h + h_1} \\ &= 2Q \log \left[\frac{h + \sqrt{h^2 - r^2}}{r} \cdot \frac{2a + h - h_1}{2a + h + h_1} \right] \end{aligned}$$

$$\therefore C = \frac{1}{2 \log \left(\frac{h + \sqrt{h^2 - r^2}}{r} \cdot \frac{2a + h - h_1}{2a + h + h_1} \right)} \text{ to neutral (3)}$$

Approximation.—Frequently, in fact almost always, the following approximation can be made:

$$h = h_1.$$

$$\therefore C = \frac{1}{2 \log \left(\frac{h + \sqrt{h^2 - r^2}}{r} \cdot \frac{a}{a + h} \right)} \quad (4)$$

If furthermore r^2 is small compared with $r_1^2 - a^2$, and is small compared with h^2 , then,

$$h = \frac{r_1^2 - a^2}{2a}, \text{ and } \frac{h + \sqrt{h^2 - r^2}}{r} = \frac{2h}{r} = \frac{r_1^2 - a^2}{ar},$$

$$\text{thus, } C = \frac{1}{2 \log \left(\frac{2a}{r} \cdot \frac{r_1^2 - a^2}{r_1^2 + a^2} \right)}, \text{ the capacity to neutral (5)}$$

Thus, the capacity between the two conductors is approximately:

$$C = \frac{1}{4 \log \left(\frac{2a}{r} \cdot \frac{r_1^2 - a^2}{r_1^2 + a^2} \right)} \quad (6)$$

or, in microfarads per 1000 ft. of cable,

$$C = \frac{0.00367}{\log_{10} \left(\frac{2a}{r} \cdot \frac{r_1^2 - a^2}{r_1^2 + a^2} \right)} \quad (7)$$

To determine the capacity of the two conductors in parallel against the sheath, the two conductors are given positive charges, $+Q$, and hence the charges on the images are $-Q$.

The potential of A due to its own charge and the charge on its image is:

$$V'_A = 2Q \log \frac{h + \sqrt{h^2 - r^2}}{r}.$$

The potential of A due to the charges on B and its image is:

$$V''_A = 2Q \log \frac{2a + h + h_1}{2a + h - h_1}.$$

$$\therefore V_A = 2Q \log \left(\frac{h + \sqrt{h^2 - r^2}}{2} \cdot \frac{2a + h + h_1}{2a + h - h_1} \right) \quad (8)$$

or, using the same approximations as before,

$$V_A = 2Q \log \left(\frac{r_1^4 - a^4}{2a^3r} \right) \quad (9)$$

The potential of the sheath, if insulated, due to the charges in A and its image is:

$$V'_s = 2Q \log \frac{h_1 + \sqrt{h_1^2 + r_1^2}}{r_1}.$$

Similarly, due to B and its image is:

$$V''_s = 2Q \log \frac{h_1 + \sqrt{h_1^2 + r_1^2}}{r_1}$$

$$\therefore V_s = 4Q \log \frac{h_1 \sqrt{h_1^2 + r_1^2}}{r_1} \quad (10)$$

Using the same approximations as before,

$$V_s = 4Q \log \frac{r_1}{a} \quad (11)$$

Thus the potential difference between the sheath and either of the conductors (when they are connected in parallel) is approximately:

$$V = V_A - A_s = 2Q \log \frac{r_1^4 - a^4}{2a^3r} - 2Q \log \left(\frac{r_1}{a} \right)^2$$

$$= 2Q \log \frac{r_1^4 - a^4}{2arr_1^2} \quad (12)$$

Thus the total capacity between the two conductors in parallel and the sheath is:

$$C = \frac{1}{\log \left(\frac{r_1^4 - a^4}{2arr_1^2} \right)} \quad (13a)$$

In connection with this it may be of interest to determine the capacity between the conductor and the sheath in a single conductor, eccentric cable, Fig. 115.

The potential of A due to its own charge and the charge on its image is:

$$V_A = 2Q \log \frac{h_1 + \sqrt{h_1^2 + r^2}}{r}$$

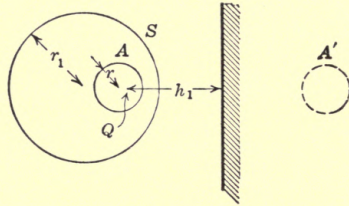

FIG. 115.

The potential of the sheath due to the charge on A and its image is:

$$V_s = 2Q \log \frac{h_1 + \sqrt{h_1^2 + r_1^2}}{r_1}$$

$$\therefore V_A - V_s = 2Q \log \left(\frac{r_1}{r} \cdot \frac{h_1 + \sqrt{h_1^2 + r^2}}{h_1 + \sqrt{h_1^2 + r_1^2}} \right)$$

$$\therefore C = \frac{1}{2 \log \left(\frac{r_1}{r} \cdot \frac{h_1 + \sqrt{h_1^2 + r^2}}{h_1 + \sqrt{h_1^2 + r_1^2}} \right)} \quad (13)$$

Denoting the conductor A with 1, B with 2 and the sheath with 3, the values of $K_{1.1}$, $K_{1.2}$ and $K_{1.3}$, are respectively identical with $K_{2.2}$, $K_{2.1}$ and $K_{2.3}$. To determine them we have

$$Q_1 = K_{1.1}V_1 + K_{1.2}V_2 + K_{1.3}V_3,$$

$$Q_2 = K_{2.1}V_1 + K_{2.2}V_2 + K_{2.3}V_3,$$

and,

$$Q_3 = K_{3.1}V_1 + K_{3.2}V_2 + K_{3.3}V_3.$$

If we are concerned with the distribution of currents in the conductors and lead sheath, it is convenient to consider the sheath grounded, that is, $V_3 = 0$.

$$\therefore Q_1 = K_{1.1}V_1 + K_{1.2}V_2,$$

$$Q_2 = K_{2.1}V_1 + K_{2.2}V_2,$$

and,

$$Q_3 = K_{3.1}V_1 + K_{3.2}V_2.$$

If then $V_1 = V_2 = V$, that is, if both conductors are given the same positive charge, then

$$Q_1 = V(K_{1.1} + K_{1.2}) \quad \therefore C = K_{1.1} + K_{1.2};$$

but C has been determined in (12) which gives,

$$C = \frac{1}{2 \log \left(\frac{r_1^4 - a^4}{2ar_1^2r} \right)} \quad \therefore K_{1.1} + K_{1.2} = \frac{1}{2 \log \left(\frac{r_1^4 - a^4}{2ar_1^2r} \right)} \quad (14)$$

If the two conductors have potentials V_1 and $-V_1$, respectively, then:

$$Q_1 = K_{1.1}V_1 + K_{1.2}V_2 = V_1(K_{1.1} - K_{1.2}), \\ \therefore C = K_{1.1} - K_{1.2}.$$

This capacity has been given in (5), which is:

$$C = \frac{1}{2 \log \left(\frac{2a}{r} \cdot \frac{r_1^2 - a^2}{r_1^2 + a^2} \right)} \\ \therefore K_{1.1} + K_{1.2} = \frac{1}{2 \log \left(\frac{2a}{r} \cdot \frac{r_1^2 - a^2}{r_1^2 + a^2} \right)} \quad (15)$$

From equations (14) and (15) the values of $K_{1.1}$ and $K_{1.2}$ are readily obtained.

Consider finally that when the two conductors are in parallel, that is, at the same potential and the charging current returns over the grounded sheath, we have,

$$Q_1 + Q_2 + Q_3 = 0, \text{ and } V_1 = V_2 = V. \\ \therefore (K_{1.1} + K_{1.2} + K_{2.1} + K_{2.2} + K_{3.1} + K_{3.2}) V = 0,$$

$$\text{or,} \quad 2K_{1.1} + 2K_{1.2} + 2K_{1.3} = 0. \\ \therefore K_{1.3} = - (K_{1.1} + K_{1.2}) \quad (16)$$

Problems.—Find the charging current under the conditions shown in Figs. 116–120, when $r_1 = 4r$; $a = 2r$; $\therefore h = 2.75r$; $h_1 = 2.55r$; $K_{1.1} + K_{1.2} = 0.4$; $K_{1.1} - K_{1.2} = 0.57$ $\therefore K_{1.1} = 0.485$; $K_{1.2} = 0.085$ and $K_{1.3} = -0.4$ (using no approximations).
(a) (Fig. 116.) $V_1 = V_2, V_3 = 0$.

$$\therefore Q_1 = V_1(K_{1.1} + K_{1.2}),$$

$$Q_2 = V_1(K_{1.2} + K_{2.2}).$$

$$\therefore i_1 = (K_{1.1} + K_{1.2}) \frac{dV}{dt},$$

$$\text{and } i_2 = (K_{1.1} + K_{1.2}) \frac{dV}{dt}.$$

the total charging current is

$$\therefore i = 2(K_{1.1} + K_{1.2}) \frac{dV}{dt} = 0.8 \frac{dV}{dt}.$$

(b) (Fig. 117.) $Q_1 = K_{1.1}V_1 + K_{1.2}V_2,$

$$Q_2 = K_{1.1}V_1 + K_{2.2}V_2 = 0 \therefore V_2 = -\frac{K_{1.2}}{K_{1.1}} V_1.$$

$$\therefore Q_1 = V_1 \left(K_{1.1} - \frac{K_{1.2}^2}{K_{1.1}} \right) = \left(\frac{K_{1.1}^2 - K_{1.2}^2}{K_{1.1}} \right) V_1.$$

$$\therefore i = \frac{K_{1.1}^2 - K_{1.2}^2}{K_{1.1}} \frac{dV}{dt} = 0.47 \frac{dV}{dt}.$$

(c) (Fig. 118.) $V_2 = -V_1, V = 2V_1.$

$$Q_1 = K_{1.1}V_1 + K_{1.2}V_2 = V_1(K_{1.1} - K_{1.2})$$

$$= \frac{V}{2} (K_{1.1} - K_{1.2}).$$

$$\therefore i = \frac{K_{1.1} - K_{1.2}}{2} \frac{dV}{dt} = 0.285 \frac{dV}{dt}.$$

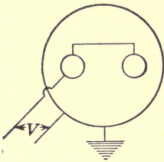

FIG. 116.

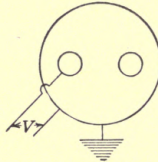

FIG. 117.

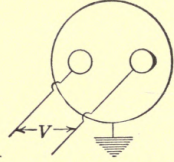

FIG. 118.

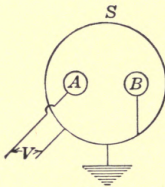

FIG. 119.

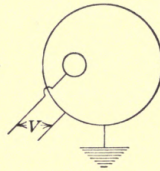

FIG. 120.

(d) (Fig. 119.) $V_2 = 0.$

$$\therefore Q_1 = K_{1.1}V_1 + K_{1.2}V_2 = K_{1.1}V_1.$$

$$\therefore i_A = K_{1.1} \frac{dV}{dt} = 0.485 \frac{dV}{dt}.$$

$$Q_2 = K_{2.1}V_1 + K_{2.2}V_2 = K_{1.2}V_1.$$

$$\therefore i_B = K_{1.2} \frac{dV}{dt} = -0.085 \frac{dV}{dt}.$$

$$Q_3 = K_{3.1}V_1 + K_{3.2}V_2 = K_{1.3}V_1.$$

$$\therefore i_s = K_{1.3} \frac{dV}{dt} = -0.4 \frac{dV}{dt}.$$

The potential of A due to the charges on B and B' is:

$$V = 2Q_B \log \frac{x}{y}$$

The potential of A due to the charges on C and C' is:

$$V = 2Q_c \log \frac{x}{y}$$

$$\therefore V_A = 2Q_A \log \frac{h_1 + \sqrt{h_1^2 + r^2}}{r} + 2(Q_B + Q_c) \log \frac{x}{y} \quad (2)$$

x is the distance between the inverse point of B' and the center of A , and y is the distance between the inverse point of B and the center of A .

With a very slight approximation, the distance y may be counted between the respective centers, thus,

$$y = a\sqrt{3} \quad (3)$$

and,

$$x^2 = (h + h_1 + a)^2 + a^2 - 2a(h + h_1 + a) \cos 120^\circ \quad (4)$$

let $h + h_1 + a = D$ then,

$$x^2 = D^2 + a^2 + aD \quad (5)$$

It has been shown previously, that since the sheath is an equipotential surface,

$$(a + \alpha)D = r_1^2 = (a + h - h_1)D = r_1^2, \\ \therefore D = \frac{r_1^2}{a + h - h_1} \quad (6)$$

Approximations based on the usual conditions, that h is very nearly the same as h_1 and r^2 is small compared with h^2 .

Referring to equation (2),

$$\frac{h_1 + \sqrt{h_1^2 + r^2}}{r} = \frac{2h}{r} = \frac{D - a}{r} \quad (7)$$

Referring to (6),
$$D = \frac{r_1^2}{a + h - h_1} = \frac{r_1^2}{a} \quad (8)$$

$$\therefore x = \frac{\sqrt{r_1^4 + a^4 + r_1^2 a^2}}{a} \quad (9)$$

Referring to (3),
$$y = a\sqrt{3} \quad (10)$$

The potential of A due to charges on A and A' is $= 2Q_A \log \frac{D-a}{r}$.

The potential of B due to charges on A and A' is $= 2Q_A \log \frac{x}{a\sqrt{3}}$.

The potential of C due to charges on A and A' is $= 2Q_A \log \frac{x}{a\sqrt{3}}$.

The potential of A due to charges on B and B' is $= 2Q_B \log \frac{x}{a\sqrt{3}}$.

The potential of B due to charges on B and B' is $= 2Q_B \log \frac{D-a}{r}$.

The potential of C due to charges on B and B' is $= 2Q_B \log \frac{x}{a\sqrt{3}}$.

The potential of A due to charges on C and C' is $= 2Q_c \log \frac{x}{a\sqrt{3}}$.

The potential of B due to charges on C and C' is $= 2Q_c \log \frac{x}{a\sqrt{3}}$.

The potential of C due to charges on C and C' is $= 2Q_c \log \frac{D-a}{r}$.

Since $\Sigma V_A + \Sigma V_B + \Sigma V_c = 0$ in a three-phase system, we get, by adding all the equations given above,

$$2(Q_A + Q_B + Q_c) \left(\log \frac{D-a}{r} + 2 \log \frac{x}{a\sqrt{3}} \right) = 0$$

or,
$$Q_A + Q_B + Q_c = 0 \quad (11)$$

which really needed no proof from our knowledge of the characteristics of the three-phase system.

From (11) follows that $Q_B + Q_c = -Q_A$.

$$\begin{aligned} \therefore V_A &= 2Q_A \log \frac{D-a}{r} - 2Q_A \log \frac{x}{a\sqrt{3}} \\ &= 2Q_A \log \left(\frac{D-a}{r} \cdot \frac{a\sqrt{3}}{x} \right) \end{aligned} \quad (12)$$

\therefore the capacity of A to ground or neutral is:

$$\begin{aligned} C &= \frac{Q_A}{V_A} = \frac{1}{2 \log \left(\frac{D-a}{r} \cdot \frac{a\sqrt{3}}{x} \right)} \\ &= \frac{1}{2 \log \left(\frac{a\sqrt{3}(r_1^2 - a^2)}{r\sqrt{r_1^4 + a^4 + r_1^2 a^2}} \right)} \end{aligned} \quad (13)$$

or in microfarads per 1000 ft. of cable, to neutral,

$$C_{m-f.} = \frac{0.00736}{\log_{10} \frac{a\sqrt{3}(r_1^2 - a^2)}{r\sqrt{r_1^4 + a^4 + r_1^2 a^2}}} \quad (14)$$

In order to determine MAXWELL'S coefficients, by symmetry, we have:

$$\begin{aligned} K_{1,1} &= K_{2,2} = K_{3,3}, \\ K_{1,2} &= K_{2,3} = K_{3,1}, \\ \text{and, } K_{1,0} &= K_{2,0} = K_{3,0}. \end{aligned}$$

where index o represents the sheath. It is necessary to calculate the capacity between all three conductors and the sheath.

Assume thus that the three conductors are given the same positive charge Q , and that the images therefore have charges $-Q$. The potential of A due to the three charges is evidently

$$\begin{aligned} V_A &= 2Q \log \frac{D-a}{r} + 2Q \log \frac{x}{a\sqrt{3}} + 2Q \log \frac{x}{a\sqrt{3}} \\ &= 2Q \log \left(\frac{(D-a)}{r} \cdot \frac{x^2}{3a^2} \right) \quad (15) \end{aligned}$$

The potential of the sheath is due to the charges in the three conductors and since the sheath is symmetrical with reference to each conductor and its image, we get:

$$V_0 = 3 \times 2Q \log \frac{h_1 + \sqrt{h_1^2 + r_1^2}}{r_1},$$

or, from the illustration, neglecting α ,

$$V_0 \cong 3 \times 2Q \log \frac{D-r_1}{r_1-a} = 2Q \log \left(\frac{D-r_1}{r_1-a} \right)^3;$$

or since $aD = r_1^2$,

$$V_0 = 2Q \log \left(\frac{r_1}{a} \right)^3 \quad (16)$$

$$\begin{aligned} \therefore V_A - V_0 &= 2Q \log \left(\frac{D-a}{r} \cdot \frac{x^2}{3a^2} \cdot \frac{a^3}{r_1^3} \right) \\ &= 2Q \log \left(\frac{D-a}{r} \cdot \frac{x^2 a}{3r_1^3} \right) = 2Q \log \frac{r_1^6 - a^6}{3r_1^3 a^2 r} \quad (17) \end{aligned}$$

$$\therefore C = \frac{1}{2 \log \frac{r_1^6 - a^6}{3r_1^3 a^2 r}}, \text{ between a conductor and the sheath.}$$

It is now possible to determine the values of $K_{1,1}$, $K_{1,2}$ and $K_{1,0}$. Assume that the sheath is grounded, that is, $V_0 = 0$.

$$\therefore Q_1 = K_{1,1}V_1 + K_{1,2}V_2 + K_{1,3}V_3 = K_{1,1}V_1 + K_{1,2}(V_2 + V_3).$$

$$\text{Since } V_1 + V_2 + V_3 = 0, \quad V_2 + V_3 = -V_1.$$

$$\therefore Q_1 = (K_{1,1} - K_{1,2})V_1.$$

It follows then from (13) that,

$$K_{1,1} - K_{1,2} = \frac{1}{2 \log \left(\frac{a\sqrt{3}(r_1^2 - a^2)}{r\sqrt{r_1^4 + a^4 + r_1^2 a^2}} \right)} \quad (19)$$

Considering next the case when all three conductors have the same charge, then:

$$Q_1 = K_{1,1}V_1 + K_{1,2}V_2 + K_{1,3}V_3 = (K_{1,1} + K_{1,2} + K_{1,3})V_1 = (K_{1,1} + 2K_{1,2})V_1.$$

From equation (18) it follows that,

$$K_{1,1} + 2K_{1,2} = \frac{1}{2 \log \left(\frac{r_1^6 - a^6}{3r_1^3 a^2 r} \right)} \quad (20)$$

From (19) and (20) $K_{1,1}$ and $K_{1,2}$ can be solved.

To determine $K_{1,0}$, assume that not only the three conductors but also the sheath is given a potential V , in which case the charge is confined to the sheath only. Then:

$$0 = (K_{1,1} + K_{1,2} + K_{1,3} + K_{1,0})V, \therefore K_{1,1} + 2K_{1,2} + K_{1,0} = 0;$$

$$0 = (K_{2,1} + K_{2,2} + K_{2,3} + K_{2,0})V, \therefore K_{1,1} + 2K_{1,2} + K_{1,0} = 0;$$

$$0 = (K_{3,1} + K_{3,2} + K_{3,3} + K_{3,0})V, \therefore K_{1,1} + 2K_{1,2} + K_{1,0} = 0;$$

any one of these equations gives:

$$K_{1,0} = - (K_{1,1} + 2K_{1,2}) \quad (21)$$

Thus $K_{1,0}$ is determined.

Problem.—Verify the equations of the charging current under the conditions given below (Figs. 122–130) and apply the following numerical values:

$$r_1 = 4r, \quad a = 2r.$$

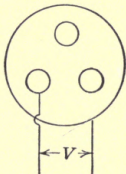

FIG. 122.

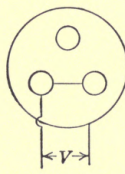

FIG. 123.

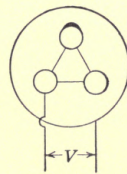

FIG. 124.

$$\text{(Fig. 122)} \quad i = \left(K_{1,1} - \frac{2K_{1,2}^2}{K_{1,1} + K_{1,2}} \right) \frac{dV}{dt} = 0.66 \frac{dV}{dt}.$$

$$\text{(Fig. 123)} \quad i = 2 \left(K_{1,1} + K_{1,2} - \frac{2K_{1,2}^2}{K_{1,1}} \right) \frac{dV}{dt} = 0.826 \frac{dV}{dt}.$$

(Fig. 124) $i = 3(K_{1.1} + 2K_{1.2}) \frac{dV}{dt} = 0.903 \frac{dV}{dt}$.

(Fig. 125) $i_1 = \frac{K_{1.1}^2 - K_{1.2}^2}{K_{1.1}} \frac{dV}{dt} = 1.03 \frac{dV}{dt}$.

$i_2 = \frac{K_{1.1}K_{1.2} - K_{1.2}^2}{K_{1.1}} \frac{dV}{dt} = 0.608 \frac{dV}{dt}$.

$i_0 = \frac{2K_{1.2}^2}{K_{1.1}} - K_{1.1} - K_{1.2} = -0.418 \frac{dV}{dt}$.

$\Sigma i = 0 = 0$.

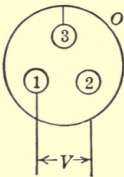

FIG. 125.

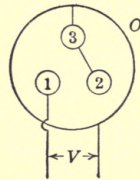

FIG. 126.

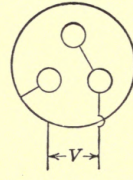

FIG. 127.

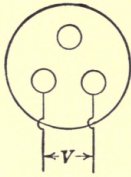

FIG. 128.

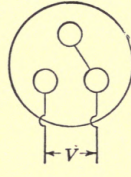

FIG. 129.

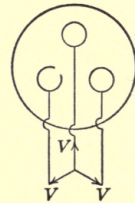

FIG. 130.

(Fig. 126) $i_1 = K_{1.1} \frac{dV}{dt} = 1.187 \frac{dV}{dt}$.

$i_2 = K_{1.2} \frac{dV}{dt} = -0.443 \frac{dV}{dt}$.

$i_3 = K_{1.2} \frac{dV}{dt} = -0.443 \frac{dV}{dt}$.

$i_0 = K_{1.0} \frac{dV}{dt} = -0.301 \frac{dV}{dt}$.

$\Sigma i = 0 = 0$.

(Fig. 127) $i = 2(K_{1.1} + K_{1.2}) \frac{dV}{dt} = 1.488 \frac{dV}{dt}$.

(Fig. 128) $i = \frac{K_{1.1} - K_{1.2}}{2} \frac{dV}{dt} = 0.372 \frac{dV}{dt}$.

(Fig. 129) $i = \frac{2}{3}(K_{1.1} - K_{1.2}) \frac{dV}{dt} = 0.495 \frac{dV}{dt}$.

(Fig. 130) Three-phase: $i = (K_{1.1} - K_{1.2}) \frac{dV}{dt} = 0.744 \frac{dV}{dt}$.

CHAPTER XXII

THE ELECTROSTATIC EFFECT OF A THREE-PHASE LINE ON AN ADJACENT WIRE OR WIRES

The potential of the wire W , Fig. 131, due to A , B , and C and their images is obviously:

$$\begin{aligned} V &= 2Q_A \log \frac{r_2}{r_1} + 2Q_B \frac{r_4}{r_3} + 2Q_C \log \frac{r_6}{r_5} \\ &= 2Q_A a_1 + 2Q_B b_1 + 2Q_C c_1 \end{aligned} \quad (1)$$

where

$$a_1 = \log \frac{r_2}{r_1},$$

$$b_1 = \log \frac{r_4}{r_3},$$

and,

$$c_1 = \log \frac{r_6}{r_5}.$$

If C is the average capacity of the three lines against neutral, then: $Q_A = Ce_1$, $Q_B = Ce_2$, and $Q_C = Ce_3$, where e_1 , e_2 and e_3 are the instantaneous values of the Y voltages.

$$\begin{aligned} \therefore V &= 2C(e_1 a_1 + e_2 b_1 + e_3 c_1) \\ &= 2CE[a_1 \sin \theta + b_1 \sin (\theta + 120^\circ) + c_1 \sin (\theta + 240^\circ)]. \\ \therefore V_{max.} &= 2EC \sqrt{a_1^2 + b_1^2 + c_1^2 - a_1 b_1 - a_1 c_1 - b_1 c_1} \\ &= 2EC \sqrt{a_1(a_1 - b_1) + b_1(b_1 - c_1) + c_1(c_1 - a_1)} \end{aligned} \quad (2)$$

where E is the maximum value of the Y voltage, that is, of the voltage to neutral.

To determine the average capacity of the three wires: The potential of A , Fig. 132, due to its own and the other charges is evidently,

$$V_A = 2Q_A \log \frac{R_2}{r} + 2Q_B \log \frac{R_4}{R_3} + 2Q_C \log \frac{R_6}{R_5}.$$

If the average value of R_2 , R_4 and R_6 is R_1 , and the average

values of R_3 and R_5 is D , then the potential of A can be reasonably well expressed as:

$$\begin{aligned} V_A &= 2Q_A \log \frac{R_1}{r} + 2Q_B \log \frac{D}{R_1} + 2Q_C \log \frac{D}{R_1} \\ &= 2Q_A \log \frac{R_1}{r} + 2(Q_B + Q_C) \log \frac{D}{R_1} \end{aligned} \quad (3)$$

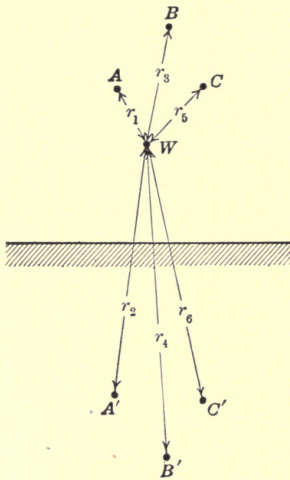

FIG. 131.

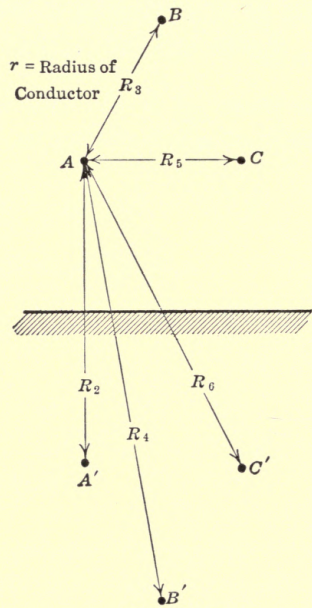

FIG. 132.

But $Q_B + Q_C = -Q_A$, thus

$$\begin{aligned} V_A &= 2Q_A \log \left(\frac{R_1}{r} \cdot \frac{D}{R_1} \right) = 2Q_A \log \frac{D}{r} \\ \therefore C &= \frac{1}{2 \log \frac{D}{r}} \end{aligned} \quad (4)$$

where D is the average distance between the conductors.

$$\therefore V_{max.} = \frac{E}{\log \frac{D}{r}} \sqrt{a_1(a_1 - b_1) + b_1(b_1 - c_1) + c_1(c_1 - a_1)} \quad (5)$$

Problem.—Prove that the maximum value of the induced potential on a telegraph wire placed under a three-phase transmission line of 100,000 volts (effective) between the lines is

approximately 3100 volts, when H = average height of transmission wires above ground = 1500 cm., D = 300 cm., and r = 0.5 cm. The telegraph wire is 800 cm. above the ground, and 50 cm. to the left of the center line of the pole.

It is seen that when the three-phase line is operating under normal conditions, the voltage induced in an adjacent wire is only a few per cent., in this case only 3 per cent. of the line voltage. If, however, one of the three-phase lines is grounded, so that the system is unbalanced electrostatically, then very considerable voltage is induced as will be shown.

If $e_1 = E \sin \theta$,

$e_2 = E \sin (\theta + 120^\circ)$,

and, $e_3 = E \sin (\theta + 240^\circ)$

are the Y voltages or phase voltages, then it is well known that the line voltages are:

$V_1 - V_3 = E\sqrt{3} \sin (\theta + 30^\circ)$,

and, $V_2 - V_3 = E\sqrt{3} \sin (\theta + 90^\circ)$.

Therefore, if phase No. 3 is grounded or at zero potential, then we have the relation between the line voltage as shown in Fig. 133. The line voltages differ 60° in time phase, when one phase is grounded.

For the sake of simplicity, let:

$V_1 - V_3 = E\sqrt{3} \sin \theta = V_a;$

$V_2 - V_3 = E\sqrt{3} \sin (\theta + 60^\circ) = V_b;$

$V_3 = 0 = V_c.$

or, $V_a = E_0 \sin \theta;$

where $E_0 = E\sqrt{3}.$

$V_b = E_0 \sin (\theta + 60^\circ);$

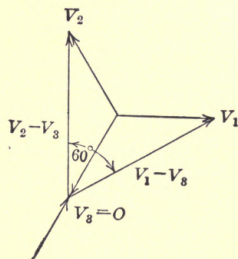

FIG. 133.

Using MAXWELL'S equation, applying index e for ground, and remembering that $V_c = V_e = 0$, we have,

$Q_a = K_{1.1}V_a + K_{1.2}V_b,$

$Q_b = K_{2.1}V_a + K_{2.2}V_b,$

$Q_c = K_{3.1}V_a + K_{3.2}V_b,$

and,

$Q_e = K_{e.1}V_a + K_{e.2}V_b.$

But $K_{1.1} = K_{2.2}$, $K_{1.2} = K_{1.3}$ and $K_{e.1} = K_{e.2}$ approximately.

$$\therefore Q_a = K_{1.1}V_a + K_{1.2}V_b,$$

$$Q_b = K_{1.2}V_a + K_{1.1}V_b,$$

$$Q_c = K_{1.2}V_a + K_{1.2}V_b,$$

and, $Q_e = K_{1.e}V_a + K_{1.e}V_b.$

$$\therefore Q_a = K_{1.1}E_0 \sin \theta + K_{1.2} E_0 \sin (\theta + 60)$$

$$= E_0(K_{1.1} + 0.5K_{1.2}) \sin \theta + \frac{\sqrt{3}}{2} E_0 K_{1.2} \cos \theta \quad (6)$$

$$Q_b = K_{1.2} E_0 \sin \theta + K_{1.1} E_0 \sin (\theta + 60^\circ) = E_0(K_{1.2} + 0.5K_{1.1})$$

$$\sin \theta + \frac{\sqrt{3}}{2} K_{1.1} \cos \theta \quad (7)$$

$$Q_c = K_{1.2}(V_a + V_b) = E_0K_{1.2}(1.5 \sin \theta + \frac{\sqrt{3}}{2} \cos \theta) \quad (8)$$

$$\text{and, } Q_e = K_{1.e}(V_a + V_b) = E_0K_{1.e}(1.5 \sin \theta + \frac{\sqrt{3}}{2} \cos \theta) \quad (9)$$

Assuming for the present that the values of the MAXWELL'S coefficients are known, it is then possible to obtain, in a manner similar to that used for the balanced system, the potential of the telegraph wire.

While in this case we deal with four charges, the effect of the charge of the earth is not felt at the telegraph wire, because the earth may be considered as an infinite cylinder, enclosing all wires; thus the effect of its charge on any point inside it, results in no potential. The potential of the wire is now readily obtained from equation (1). The charging current in the three wires and the earth is found from equations (6) to (9), remembering that $\theta = \omega t$.

$$\therefore \left. \begin{aligned} i_a &= \frac{dQ_a}{dt} = E_0\omega \left[(K_{1.1} + 0.5K_{1.2}) \cos \omega t - \frac{\sqrt{3}}{2} K_{1.2} \sin \omega t \right]; \\ i_b &= E_0\omega \left[(K_{1.2} + 0.5K_{1.1}) \cos \omega t - \frac{\sqrt{3}}{2} K_{1.1} \sin \omega t \right]; \\ i_c &= E_0\omega \left[K_{1.2} (1.5 \cos \omega t - \frac{\sqrt{3}}{2} \sin \omega t) \right]; \\ i_e &= E_0\omega \left[K_{1.e} (1.5 \cos \omega t - \frac{\sqrt{3}}{2} \sin \omega t) \right]. \end{aligned} \right\} (10)$$

It remains now to determine the values of the MAXWELL'S coefficients.

Give each of the three conductors the same charge Q , and assume average values of the distance between the conductor

and ground as H and the distance between conductors as D . Then we have approximately the following relation:

$$V_a = 2Q \log \frac{2H}{r} + 2Q \log \frac{2H}{D} + 2Q \log \frac{2H}{D} = 2Q \log \frac{8H^3}{D^2r}$$

$$\therefore \frac{Q}{V_a} = \frac{1}{2 \log \frac{8H^3}{D^2r}}$$

We have also,

$$Q = K_{1.1}V_a + K_{1.2}V_b + K_{1.3}V_c = V_a(K_{1.1} + 2K_{1.2}).$$

$$\therefore K_{1.1} + 2K_{1.2} = \frac{1}{2 \log \frac{8H^3}{D^2r}} \tag{11}$$

Give now three-phase charges to the three conductors, then,

$$Q_A = K_{1.1}V_a + K_{1.2}V_b + K_{1.3}V_c = K_{1.1}V_a - K_{1.2}V_b = V_a(K_{1.1} - K_{1.2}).$$

Thus $K_{1.1} - K_{1.2}$ is the capacity of one of the three lines against the neutral, which has been shown to be:

$$C = \frac{1}{2 \log \frac{D}{r}}$$

$$\therefore K_{1.1} - K_{1.2} = \frac{1}{2 \log \frac{D}{r}} \tag{12}$$

From (11) and (12), the numerical values of $K_{1.1}$ and $K_{1.2}$ can be determined, as well as $K_{1.3}$, so that all the coefficients are known.

It may be of interest to consider the problem from another point of view.

By grounding one conductor, while the potential difference between the conductors is not changed, the potential of the system of three conductors has been changed.

It should be possible, therefore, to calculate the charge Q_0 , which should be given to each conductor, in order that the new potential distribution shall exist. The charge should obviously be such that the potential of C shall be reduced to zero. Before grounding, the potential was $+V_c$, and hence Q_0 should be such as to give C a potential of $-V_c$.

$$\therefore -V_c = 2Q_0 \log \frac{R_2}{r} + 2Q_0 \log \frac{R_4}{R_3} + 2Q_0 \log \frac{R_6}{R_5}$$

$$\begin{aligned}
 &= 2Q_0 \left[\log \frac{2H}{r} + \log \frac{2H}{D} + \log \frac{2H}{D} \right] \\
 &= 2Q_0 \log \frac{8H^3}{rD^2}, \text{ using the approximations.}
 \end{aligned}$$

Since $-V_c = -E \sin(\omega t + 240^\circ)$, the maximum value of the charge is $Q_0 = \frac{-E}{2 \log \frac{8H^3}{rD^2}}$.

The charges on the conductor *A* after grounding the conductor *C* are therefore,

$$Q_A + Q_0 = E \sin \omega t \left[\frac{1}{2 \log \frac{D}{r}} - \frac{1}{2 \log \frac{8H^3}{rD^2}} \right].$$

Similar expressions are of course readily written for the charges on the conductors *B* and *C*.

The potential of the telegraph line after grounding is thus,

$$V = 2 [(Q_A + Q_0)a_1 + (Q_B + Q_0)b_1 + (Q_c + Q_0)c_1].$$

By applying these equations to the numerical example given previously, it will be found that the induced potential of the telegraph line will be 25 per cent. of the phase voltage or 14.5 per cent. of the line voltage. In the case of an insulated balanced system, it was found about 5 per cent. of the phase voltage or about 3 per cent. of the line voltage.

The Effects of a Grounded Horizontal Wire on the Distribution of Electricity in the Atmosphere.—It has been observed that frequently considerable potential difference exists between successive layers of the atmosphere. A potential gradient of 600 volts per m., or roughly 200 volts per ft., is not unusual.

It is of interest then to see how much the potential at a given height may be reduced by a grounded overhead line such as is used in high-potential transmission systems.

Assume that the gradient, not far from the earth, is 2 electrostatic units per m. (600 volts per m.). It is readily seen that the distribution can be quite closely represented by the effect of a charged cylindrical conductor, say 300 m. or more above the surface of the earth. The conductor then represents whatever cause there was for the potential gradient.

The charge per centimeter length of the fictitious conductor is determined by the fact that the potential at a certain height

is known. Thus according to the assumption, the potential at 15 m. above the ground is 30 electro-static units. Thus referring to Fig. 134,

$$V = 2Q_0 \log \frac{315}{285} = 30 \therefore Q_0 = 155.$$

Suppose now that it is desired to find the change in a grounded overhead wire of radius $r = 0.5$ cm. placed 15 m. above ground.

Since the potential of A , Fig. 135, is zero, it is evident that the potential of A due to its own charge and the charge on its image plus the potential of A due to the charge on the fictitious conductor and its image must be zero.

$$\text{Thus } 2Q \log \frac{2h}{r} + 2Q_0 \log \frac{H+h}{H-h} = 0 = 2Q \log \frac{2h}{r} + 30.$$

$$\therefore Q = -\frac{30}{2 \log \frac{2h}{r}} = \frac{15}{\log 6000} = -1.72 \text{ E.S.U.}$$

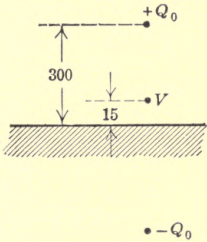

FIG. 134.

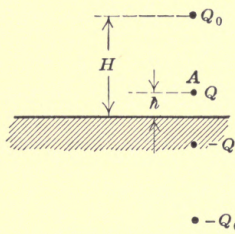

FIG. 135.

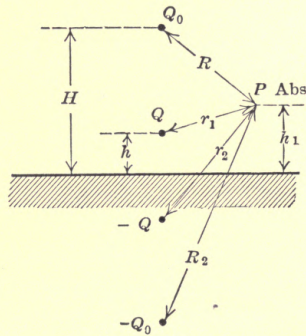

FIG. 136.

The potential at a point P , Fig. 136, distant h_1 , from the ground is then:

$V = 2Q_0 \log \frac{R_2}{R_1} + 2Q \log \frac{r_2}{r_1}$, but $2Q_0 \log \frac{R_2}{R_1}$ is, according to the first assumption of uniform gradient, $0.02h_1$ (h_1 being given in centimeters).

Thus the potential of P is:

$$V_p = 0.02h_1 - 3.44 \log \frac{r_2}{r_1} \tag{1}$$

The effect of two ground wires A and B on the potential at a point P in the vicinity of the wires:

The potential of A or B due to the fictitious and the two actual conductors and their images must be zero.

The potential of A , Fig. 137, is:

$$2Q_0 \log \frac{H+h}{H-h} + 2Q \log \frac{2h}{r} + 2Q \log \frac{r_4}{r_3} = 0 =$$

$$\text{or } 0.02h + 2Q \log \frac{2h}{r} \frac{r_4}{r_3} = 0, \therefore Q = \frac{-0.02h}{2 \log \frac{2h}{r} \frac{r_4}{r_3}} \quad (2)$$

If the wires are 2 m. apart and 15 m. from ground then $r_4 = 3010$ cm. and $r_3 = 200$ cm.

$$\therefore Q = -1.31.$$

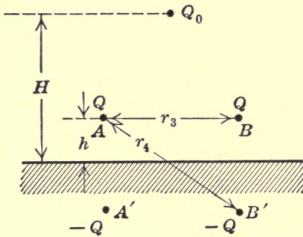

FIG. 137.

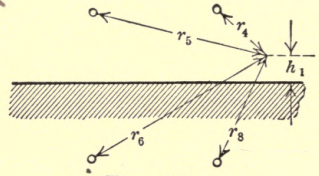

FIG. 138.

The potential at a point P , Fig. 138, is then:

$$V_p = 0.02h_1 - 2.63 \log \frac{r_6 r_8}{r_5 r_7} \quad (3)$$

It will be seen that by means of a single ground wire above a transmission line the potential is reduced by some 30 per cent., and when two ground wires are used by some 40 to 50 per cent., and that there is little gain in using ground wires of large diameter.

CHAPTER XXIII

THE CURL OF A VECTOR

In vector representation, the curl of a vector is represented by the cross-product of the differential operator ∇ and the vector. It is:

$$\nabla \times R = \text{curl } R = \begin{vmatrix} i & j & k \\ \frac{\partial}{\partial x} & \frac{\partial}{\partial y} & \frac{\partial}{\partial z} \\ X & Y & Z \end{vmatrix}$$

$$i \left(\frac{\partial Z}{\partial y} - \frac{\partial Y}{\partial z} \right) + j \left(\frac{\partial X}{\partial z} - \frac{\partial Z}{\partial x} \right) + k \left(\frac{\partial Y}{\partial x} - \frac{\partial X}{\partial y} \right) =$$

$$iC_x + jC_y + kC_z.$$

The curl of a vector is thus a vector and its components along the axes are C_x , C_y , and C_z .

It is important to analyze the meaning of this new vector.

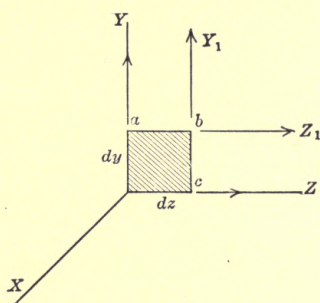

FIG. 139.

Consider a small rectangle in the y - z plane, Fig. 139. Let the component of R along the y -axis be Y and let it change to Y_1 , as we move along the z -axis from a to b .

$$\therefore Y_1 = Y + \frac{\partial Y}{\partial z} dz$$

Similarly,

$$Z_1 = Z + \frac{\partial Z}{\partial y} dy.$$

The line integral around the rectangle is then:

$$\begin{aligned} dL &= Ydy + Z_1dz - Y_1dy - Zdz \\ &= \left(\frac{\partial Z}{\partial y} - \frac{\partial Y}{\partial z} \right) dydz. \end{aligned}$$

Extending this to all three planes, we get: the line integral around dS ,

$$\begin{aligned} = dL &= \left(\frac{\partial Z}{\partial y} - \frac{\partial Y}{\partial z} \right) dydz + \left(\frac{\partial X}{\partial z} - \frac{\partial Z}{\partial x} \right) dzdx + \\ &\quad \left(\frac{\partial Y}{\partial x} - \frac{\partial X}{\partial y} \right) dxdy = C \cdot dS \end{aligned}$$

$= C \cos \alpha dS$, where α is the angle between curl C and the normal to the surface dS .

The x -component of the curl C_x is then seen to be the limit of the ratio between the line integral of the vector around a small element in the y - z plane and the area of the element. Since it is the x -component, it is, of course, at right angle to the surface, $dydz$.

In general,

$$\text{Curl} = \lim \frac{\Delta L}{\Delta S} = \frac{dL}{dS},$$

where surface dS is normal to the vector C .

Stokes's Theorem.—STOKES'S theorem states that the line integral of a vector R around any closed contour is equal to the surface integral of the curl of the vector over the surface or cap enclosed by the contour.

The theorem holds always when transforming from the line integral to the surface integral, but applies in the transformation from the surface to the line integral only when $\frac{\partial Cx}{\partial x} + \frac{\partial Cy}{\partial y} + \frac{\partial Cz}{\partial z} = 0$, that is, only when the curl has no divergence.

Depending upon the system of notations used, it is written in either of the following ways:

In vector notation, it is:

$$\oint R \cdot dr = \iint (\nabla \times R) \cdot NdS,$$

which is to be read: The line integral of the electric field intensity along the circuit is equal to the surface integral of the curl of the vector over any surface (any cap) bounded by the circuit, where N is the unit, outward drawn normal to dS .

Obviously, the theorem may also be written:

$$\begin{aligned} \int R ds \cos (Rds) &= \int (Xdx + Ydy + Zdz) \\ &= \int \int \left[l \left(\frac{\partial Z}{\partial y} - \frac{\partial Y}{\partial z} \right) + m \left(\frac{\partial X}{\partial z} - \frac{\partial Z}{\partial x} \right) + n \left(\frac{\partial Y}{\partial x} - \frac{\partial X}{\partial y} \right) \right] dS \quad (1) \end{aligned}$$

where l , m and n are defined below.

The theorem can best be proven by calculus of variations, but may be understood without mathematics by the following reasoning. Refer to Fig. 140, which shows the cap divided up into a number of small elements. It is evident that the sum of the line integrals around all these small areas resolves itself into the line integral around the contour, since all lines, except the contour, are traced in two equal and opposite directions.

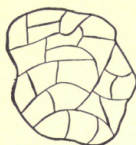

FIG. 140.

Thus if dL is the line integral around one of the small areas, then

$$\Sigma dL = \int R \cos (Rds) dS.$$

But it has been shown, that

$$dL = \left(\frac{\partial Z}{\partial y} - \frac{\partial Y}{\partial z} \right) dydz + \left(\frac{\partial X}{\partial z} - \frac{\partial Z}{\partial x} \right) dzdx + \left(\frac{\partial Y}{\partial x} - \frac{\partial X}{\partial y} \right) dxdy = C$$

$\cos \alpha dS$, where α is the angle between the curl C and the normal to the surface dS . (2)

$$\therefore dL = C \cos \alpha dS.$$

but $dydz = l dS$, where $l = \cos (Nx)$;

$dzdx = m dS$, where $m = \cos (Ny)$;

$dxdy = n dS$, where $n = \cos (Nz)$;

by substituting these values in (2), equation (1) is proved.

CHAPTER XXIV

THE EQUATION OF THE ELECTROMOTIVE FORCE

It has been shown that the potential difference between two points in an electric field is the line integral.

$$V = \int (Xdx + Ydy + Zdz) = \int Gds \quad (1)$$

where X , Y and Z are the components of the field intensities or gradient along the x , y and z axes and V is expressed in electro-static units.

It will be shown later that the conversion factor between the electro-static units and electromagnetic units of potential is the velocity of light, $v = 3 \times 10^{10}$ cm. per sec.

The e.m.f. in the electromagnetic system of units is v times that in the electro-static system of units. Equation (1) should be written:

$$V = v \int (Xdx + Ydy + Zdz) \text{ in electromagnetic units} \quad (2)$$

Experiments have also shown that the e.m.f. in electromagnetic units in a circuit is equal and opposite to the product of the turns enclosing the magnetic flux and the rate of change of the flux.

If L , M and N are the components along the x , y and z axes of the magnetic field intensity, and if l , m and n are the direction cosines of the normal to the surface dS , and if μ is the permeability then the flux is:

$$\phi = \int \int \mu (lL + mM + nN) dS = \int \int \mu H \cdot dS$$

Then the e.m.f. induced per turn is:

$$V = - \frac{d\phi}{dt} = - \frac{\partial}{\partial t} \left[\int \int \mu (lL + mM + nN) dS \right] \quad (3)$$

combining (2) and (3), and assuming μ constant,

$$v \int (Xdx + Ydy + Zdz) = -\mu \int \int \left(l \frac{\partial L}{\partial t} + m \frac{\partial M}{\partial t} + n \frac{\partial N}{\partial t} \right) dS \quad (4)$$

But from STOKES'S theorem, we can write:

$$\int (Xdx + Ydy + Zdz) = \int \int \left[l \left(\frac{\partial Z}{\partial y} - \frac{\partial Y}{\partial z} \right) + m \left(\frac{\partial X}{\partial z} - \frac{\partial Z}{\partial x} \right) + n \left(\frac{\partial Y}{\partial x} - \frac{\partial X}{\partial y} \right) \right] dS \quad (5)$$

Equating (4) and (5), we get:

$$v \left[l \left(\frac{\partial Z}{\partial y} - \frac{\partial Y}{\partial z} \right) + m \left(\frac{\partial X}{\partial z} - \frac{\partial Z}{\partial x} \right) + n \left(\frac{\partial Y}{\partial x} - \frac{\partial X}{\partial y} \right) \right] = -\mu \left[l \frac{\partial L}{\partial t} + m \frac{\partial M}{\partial t} + n \frac{\partial N}{\partial t} \right].$$

$$\left. \begin{aligned} \therefore C_x &= -\frac{\mu}{v} \frac{\partial L}{\partial t} \\ C_y &= -\frac{\mu}{v} \frac{\partial M}{\partial t} \\ C_z &= -\frac{\mu}{v} \frac{\partial N}{\partial t} \end{aligned} \right\} \quad (6)$$

and,

If the circuit be closed, a conduction current will flow, and its magnitude will depend upon the resistance.

NOTE.—If the circuit is inductive, this applies equally well, since in these equations the total variation in flux is considered.

Let I , with components u , v and w be the current density along the x , y and z axes, and ρ be the resistivity of the material. Let ds with components dx , dy and dz be an element of the circuit, and A_x , A_y and A_z be the projected areas of an elemental surface dS , then the resistance along the x -axis is $\frac{\rho}{A_x} dx$ and $dV = -(\text{resistance} \times \text{current}) = -\frac{\rho dx}{A_x} u A_x = \rho u dx$, but

$$X = -\frac{dV}{dx} = \rho u, \therefore X = \rho u.$$

Similarly, $Y = \rho v$;

and; $Z = \rho w$.

It should be noted that X , Y and Z are expressed in electrostatic units. Thus by transforming the relations to electromagnetic units, we get:

$$\rho u = vX;$$

$$\rho v = zY;$$

$$\rho w = vZ.$$

The Equations of the Current.—Let the components of the current density along the three axes be u , v and w , in electromagnetic units. Let l , m , and n be the direction cosines of the normal to surface dS ; then the total current is:

$$I = \iint (lu + mv + nw) dS.$$

It was shown by AMPERE that the work done in carrying unit pole around an element carrying current i was $4\pi i$.

The work done is $\int (Ldx + Mdy + Ndz)$, where, as usual, L , M and N are the components of the magnetic field intensity.

$$\therefore \int (Ldx + Mdy + Ndz) = 4\pi I = 4\pi \int \int (lu + mv + nw)dS.$$

But by STOKES'S theorem,

$$\int \int (Ldx + Mdy + Ndz) = \int \int (lC_x + mC_y + nC_z)dS.$$

$$\therefore \int \int (lC_x + mC_y + nC_z)dS = 4\pi \int \int (lu + mv + nw)dS.$$

$$\therefore 4\pi u = C_x = \frac{\partial N}{\partial y} - \frac{\partial M}{\partial z},$$

$$4\pi v = C_y = \frac{\partial L}{\partial z} - \frac{\partial N}{\partial x},$$

and,

$$4\pi w = C_z = \frac{\partial M}{\partial z} - \frac{\partial L}{\partial y}.$$

Energy of the Electric Field.—Consider a small cube-shaped volume $dx dy dz$, Fig. 141, in the electric field, and let the potential difference between the two sides $dx dy$ be V .

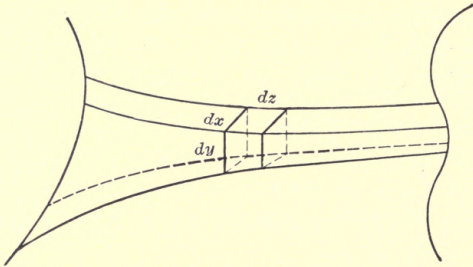

FIG. 141.

The capacity of the field enclosed by the cube has been shown to be:

$$C = \frac{KA}{4\pi d} = K \frac{dx dy}{4\pi dz}.$$

The energy stored in the field is $\frac{1}{2}CV^2$, and the potential V is Zdz , where $Z = \frac{\partial v}{\partial z}$.

$$\therefore W = \frac{1}{2} \cdot \frac{Kdx dy}{4\pi dz} Z^2 dz^2 = \frac{KZ^2 dx dy dz}{8\pi}$$

$$= \frac{KZ^2}{8\pi} dv, \text{ or the energy per unit volume} = \frac{KZ^2}{8\pi}, \text{ when only}$$

the z -component of the field is considered.

If the components of the electric field intensity R , are X , Y and Z , then, the total energy per unit volume = $W_0 = \frac{K}{8\pi} (X^2 + Y^2 + Z^2)$.

Similarly, it is proven that the energy stored per unit volume in the magnetic field is:

$$W_0 = \frac{\mu}{8\pi} (L^2 + M^2 + N^2).$$

Thus the total energy per cubic centimeter in space occupied by magnetic and electric field is:

$$W_0 = \frac{1}{8\pi} [\mu(L^2 + M^2 + N^2) + K(X^2 + Y^2 + Z^2).]$$

There appears to be no limit to the possible intensities of the magnetic field, but for the electric field in air at atmospheric pressure, experiments indicate a maximum possible gradient, or field intensity of 30,000 volts per cm., or 100 electro-static units of potential per cm.

Thus in the electric field the maximum amount of energy at normal pressure is:

$W_{maz.} = \frac{100^2}{8\pi} = 400$ ergs per cu. cm. or 0.00004 joules per cu. cm.

Maxwell's Displacement Current.—MAXWELL assumes that when a potential difference exists in any part of a dielectric, an electric displacement, or a displacement of electricity has taken place along the lines of electric intensity (force). The greater the displacement, the greater the difference in potential.

The displacement, however, is resisted by the electric elasticity of the medium, which, for the lack of a more satisfactory analogy, can be thought of as being in a way similar to that existing in an elastic body, against which a particle is pressed.

For a given potential difference, the displacement is greater the greater the specific inductive capacity; for example, if the dielectric be glass, the displacement may be five to six times as great as would be true with air or vacuum.

A metal may be considered to have zero capacity, in other words, energy can not be stored into it, but electricity would continue to pass through it as long as a potential difference existed.

Dielectrics, on the other hand, would permit electricity to flow up only to a certain distance, and the flow ceases when the

force causing the electricity to flow is exactly equal to the opposing force due to the elasticity of the dielectric.

The displacement of electricity is in the direction of the lines of electric force; since the displacement has magnitude as well as direction, it is a vector quantity.

According to MAXWELL'S theory an electric current is a time rate of change of the displacement of electricity.

The charge on a body is a measure of the displaced electricity. Indeed, MAXWELL states that a charge Q on a body causes a displacement of Q units of electricity out from the body, and he has defined the displacement D as the charge per unit area. It is then numerically equal to σ , the charge per unit area, but while σ is a scalar quantity, D is a vector.

D can be expressed as a function of the intensity R and the specific capacity K .

In air the intensity of the field is $\frac{\text{flux}}{\text{area}} = \frac{\Psi}{\text{area}} = \frac{4\pi Q}{A}$. In other dielectric of specific capacity K ,

$$R = \frac{1}{K} \frac{4\pi Q}{A} \quad \therefore Q = \frac{ARK}{4\pi}.$$

$$\text{The surface charge} = \frac{Q}{A} = \frac{ARK}{4\pi A} = \frac{RK}{4\pi}.$$

Thus the displacement D is also,

$$D = \frac{RK}{4\pi}.$$

The displacement of electricity is in the direction of the field. Thus if f , g and h are the components of the displacement, and X , Y and Z are the components of the electric field intensity, then,

$$\left. \begin{aligned} f &= \frac{KX}{4\pi}, \\ g &= \frac{KY}{4\pi}, \\ \text{and,} \\ h &= \frac{KZ}{4\pi}. \end{aligned} \right\} \begin{array}{l} \text{In these equations, the units} \\ \text{are in the electro-static system.} \end{array}$$

The amount of electricity displaced is the product of current and time, or considering current per square centimeter or current density, the displacement is the product of current density and time.

Let u_a , v_a , and w_a be the components of the current density, then:

$$\begin{aligned} u_a dt &= df, \\ v_a dt &= dg, \end{aligned}$$

and, $w_a dt = dh.$

It has been shown that the conduction current density in electro-static units was:

$$\left. \begin{aligned} u &= \frac{X}{\rho}, \\ v &= \frac{Y}{\rho}, \\ \text{and,} \\ w &= \frac{Z}{\rho}, \end{aligned} \right\} \text{ where } \rho \text{ is the specific resistance.}$$

Thus the total current density along the x -axis is:

$$n + u_a = \frac{X}{\rho} + \frac{df}{dt} = \frac{X}{\rho} + \frac{K}{4\pi} \frac{\partial X}{\partial t};$$

similarly,

$$\begin{aligned} v + v_a &= \frac{Y}{\rho} + \frac{dg}{dt} = \frac{Y}{\rho} + \frac{K}{4\pi} \frac{\partial Y}{\partial t}; \\ w + w_a &= \frac{Z}{\rho} + \frac{dh}{dt} = \frac{Z}{\rho} + \frac{K}{4\pi} \frac{\partial Z}{\partial t}. \end{aligned}$$

Thus, applying AMPERE'S relation, that in electromagnetic units the curl of the magnetic field intensity is 4π times the current density, we get:

$$\begin{aligned} \frac{4\pi}{v} (u + u_a) &= \frac{1}{v} \left(\frac{4\pi X}{\rho} + K \frac{\partial X}{\partial t} \right) = \frac{1}{v} \left[\frac{4\pi}{\rho} + K \frac{\partial}{\partial t} \right] X \\ &= \frac{\partial N}{\partial y} - \frac{\partial M}{\partial z} \end{aligned} \tag{1a}$$

similarly,

$$\frac{1}{v} \left[\frac{4\pi}{\rho} + K \frac{\partial}{\partial t} \right] Y = \frac{\partial L}{\partial z} - \frac{\partial N}{\partial x} \tag{1b}$$

and,

$$\frac{1}{v} \left[\frac{4\pi}{\rho} + K \frac{\partial}{\partial t} \right] Z = \frac{\partial M}{\partial x} - \frac{\partial L}{\partial y} \tag{1c}$$

where v at present is the unknown ratio between the units. The corresponding equations for the e.m.f. were shown to be

$$-\frac{\mu}{v} \frac{\partial L}{\partial t} = \frac{\partial Z}{\partial z} - \frac{\partial Y}{\partial x} \tag{2a}$$

$$-\frac{\mu}{v} \frac{\partial M}{\partial t} = \frac{\partial X}{\partial z} - \frac{\partial Z}{\partial x} \quad (2b)$$

$$-\frac{\mu}{v} \frac{\partial N}{\partial t} = \frac{\partial Y}{\partial x} - \frac{\partial X}{\partial y} \quad (2c)$$

By combining equations (1) and (2), it is possible to arrive at equations of the electric and magnetic field intensities in any medium—conductor or non-conductor.

Differentiate (1a) with respect to t ,

$$\therefore \left[\frac{1}{v} \frac{4\pi}{\rho} \frac{\partial X}{\partial t} + K \frac{\partial^2 X}{\partial t^2} = \frac{\partial^2 N}{\partial y \partial t} - \frac{\partial^2 M}{\partial z \partial t} \right] \quad (3)$$

Differentiate (2c) with respect to y ,

$$\therefore -\frac{\mu}{v} \frac{\partial^2 N}{\partial t \partial y} = \frac{\partial^2 Y}{\partial x \partial y} - \frac{\partial^2 X}{\partial y^2} \quad (4)$$

Differentiate (2b) with respect to z ,

$$\therefore -\frac{\mu}{v} \frac{\partial^2 M}{\partial t \partial z} = \frac{\partial^2 X}{\partial z^2} - \frac{\partial^2 Z}{\partial x \partial z} \quad (5)$$

Substitute (4) and (5) in (3), and add and subtract $\frac{\partial^2 X}{\partial x^2} = \frac{\partial}{\partial x} \left(\frac{\partial X}{\partial x} \right)$, the following equation results:

$$\frac{4\pi\mu}{\rho} \frac{\partial X}{\partial t} + K\mu \frac{\partial^2 X}{\partial t^2} = v^2 \left[\frac{\partial^2 X}{\partial x^2} + \frac{\partial^2 X}{\partial y^2} + \frac{\partial^2 X}{\partial z^2} - \frac{\partial}{\partial x} \left(\frac{\partial X}{\partial x} + \frac{\partial Y}{\partial y} + \frac{\partial Z}{\partial z} \right) \right] \quad (6)$$

which is the most general equation.

If there is no divergence, that is if we are interested in a medium having no charges, then the equation becomes:

$$4\pi\mu \frac{\partial X}{\partial t} + K\mu \frac{\partial^2 X}{\partial t^2} = v^2 \left[\frac{\partial^2 X}{\partial x^2} + \frac{\partial^2 X}{\partial y^2} + \frac{\partial^2 X}{\partial z^2} \right] = v^2 \nabla^2 X \quad (7)$$

It is readily seen that exactly similar equations not only result for the Y and Z components of the electric field intensity, but also for the components of the magnetic field intensity, L , M and N .

Special Cases.—(a) In a dielectric, $\rho = \infty$, thus the equations become:

$$\left. \begin{aligned} K\mu \frac{\partial^2 X}{\partial t^2} &= v^2 \nabla^2 X, \\ K\mu \frac{\partial^2 Y}{\partial t^2} &= v^2 \nabla^2 Y, \\ K\mu \frac{\partial^2 Z}{\partial t^2} &= v^2 \nabla^2 Z; \end{aligned} \right\} \begin{aligned} k\mu \frac{\partial^2 L}{\partial t^2} &= v^2 \nabla^2 L, \\ k\mu \frac{\partial^2 M}{\partial t^2} &= v^2 \nabla^2 M, \\ K\mu \frac{\partial^2 N}{\partial t^2} &= v^2 \nabla^2 N; \end{aligned} \quad (8)$$

or in general,

$\frac{\partial^2 U}{\partial t^2} = a^2 \nabla^2 U$, where $a^2 = \frac{v^2}{k\mu}$, and U stands for either X , Y , Z , L , M or N .

This is the well-known equation of the propagation of any disturbance at finite speed.

The velocity of the propagation is $a = \frac{v}{\sqrt{k\mu}}$. In air, $k = 1$ and $\mu = 1$, thus the velocity of propagation of the electric and magnetic field is v .

This value has been measured and found to be that of light, thus the conversion factor is the velocity of light. Thus $v = 3 \times 10^{10}$ cm/sec.

This important fact was deduced by MAXWELL in 1865.

(b) In a conductor, the specific inductive capacity may be assumed as zero, thus we get:

$$\frac{4\pi}{\rho} \frac{\partial U}{\partial t} = v^2 \nabla^2 U$$

or,

$$\frac{\partial^2 U}{\partial x^2} + \frac{\partial^2 U}{\partial y^2} + \frac{\partial^2 U}{\partial z^2} = \frac{4\pi}{v^2} \frac{\partial U}{\partial t}, \text{ in rectangular } \quad (9)$$

coördinates, and,

$$\frac{\partial^2 U}{\partial r^2} + \frac{1}{r^2} \frac{\partial^2 U}{\partial \theta^2} + \frac{\partial^2 U}{\partial z^2} + \frac{1}{r} \frac{\partial U}{\partial r} = \frac{4\pi}{v^2 \rho} \frac{\partial U}{\partial t}, \text{ in cylindrical } \quad (9)$$

Assuming, as an application, that it is desired to determine the current distribution at any time in a cylindrical conductor at any distance from the origin and any distance from the center of the conductor. If the practical system of units is used, $v^2 = 1$; and on account of circular symmetry, the term involving $\frac{\partial U}{\partial \theta}$ disappears. Thus the equation becomes:

$$\frac{\partial^2 i}{\partial r^2} + \frac{\partial^2 i}{\partial z^2} + \frac{1}{r} \frac{\partial i}{\partial r} = \frac{4\pi}{\rho} \frac{\partial i}{\partial t} \quad (10)$$

Distribution of current in a cylindrical conductor: If it is of interest to find the distribution along a radius only, the equation becomes:

$$\frac{\partial^2 i}{\partial r^2} + \frac{1}{r} \frac{\partial i}{\partial r} = \frac{4\pi}{\rho} \frac{\partial i}{\partial t} \quad (11)$$

It will be of interest to verify this equation directly. It has been shown that the work done in ergs, in taking unit pole once around a conductor carrying current I is $4\pi I$, where I is the current enclosed in the path.

Consider, for the sake of simplicity, a cylindrical conductor, Fig. 142. Let the instantaneous values of the current density at distant r from the center be i , and that at $r + dr$ be $i + \frac{\partial i}{\partial r} dr$.

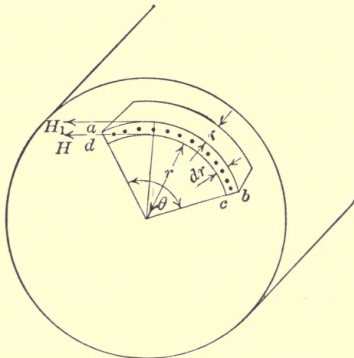

FIG. 142.

Let the magnetic field intensity at distant r be H ; and at distant $r + dr$, be $H_1 = H + \frac{\partial H}{\partial r} dr$.

The work done on unit pole in going from a to b is:

$$\begin{aligned} H_1(r + dr)\theta &= \left(H + \frac{\partial H}{\partial r} dr \right) (r + dr)\theta = \\ &= \theta \left(Hr + Hdr + r \frac{\partial H}{\partial r} dr \right), \text{ neglecting the term which involves } (dr)^2. \end{aligned}$$

The work done in going from b to c , or from d to a , is zero, because we travel on an equipotential surface.

The work done in going from c to d is $-Hr\theta$.

$$\therefore W = \theta \left(Hdr + r \frac{\partial H}{\partial r} dr \right) = \theta dr \left(H + r \frac{\partial H}{\partial r} \right).$$

And by definition given above,

$$W = 4\pi i r \theta dr, \text{ neglecting the term which involves } (dr)^2.$$

$$\therefore 4\pi i = \frac{H}{r} + \frac{\partial H}{\partial r} \quad (1)$$

The ohmic drop in voltage along 1 cm. of the conductor at the outer edge of the segment, that is, at $r + dr$ from the center, perpendicular to the paper, is:

$$\left(i + \frac{\partial i}{\partial r} dr\right)\rho, \text{ where } \rho \text{ is the specific resistance.}$$

The drop along the inner edge is $i\rho$; thus the difference in the e.m.f. at the two edges is:

$$de = \rho \left(i + \frac{\partial i}{\partial r} dr - i\right) = \rho \frac{\partial i}{\partial r} dr \quad (2)$$

This must be then the e.m.f. which is consumed by the self-induction due to the flux in the element.

$$\text{The flux in the element is } \phi = \mu H(dr \times 1 \text{ cm.}) = Hdr \quad (3)$$

$$\therefore de = \frac{\partial \phi}{\partial t} = \mu dr \frac{\partial H}{\partial t} \quad (4)$$

From (2) and (4),

$$\rho \frac{\partial i}{\partial r} dr = \mu dr \frac{\partial H}{\partial t}, \text{ or, } \rho \frac{\partial i}{\partial r} = \mu \frac{\partial H}{\partial t} \quad (5)$$

Differentiating (1) with respect to t ,

$$\therefore 4\pi \frac{\partial i}{\partial t} = \frac{1}{r} \frac{\partial H}{\partial t} + \frac{\partial^2 H}{\partial r \partial t} \quad (6)$$

Differentiating (5) with respect to r ,

$$\rho \frac{\partial^2 i}{\partial r^2} = \mu \frac{\partial^2 H}{\partial t \partial r} \quad (7)$$

Substitute (7) in (6),

$$\therefore 4\pi \frac{\partial i}{\partial t} = \frac{1}{r} \frac{\partial H}{\partial t} + \frac{\rho}{\mu} \frac{\partial^2 i}{\partial r^2} \quad (8)$$

Substitute the value of $\frac{\partial H}{\partial t}$ from (5) in (8),

$$\therefore 4\pi \frac{\partial i}{\partial t} = \frac{1}{r} \frac{\rho}{\mu} \frac{\partial i}{\partial r} + \frac{\rho}{\mu} \frac{\partial^2 i}{\partial r^2},$$

or,

$$\frac{4\pi\mu}{\rho} \frac{\partial i}{\partial t} = \frac{\partial^2 i}{\partial r^2} + \frac{1}{r} \frac{\partial i}{\partial r} \quad (9)$$

in electromagnetic system of units.

Equation (9) is very important in connection with problems of heat as well as electricity, it has been studied by great mathematicians, notably, MAXWELL and LORD RAYLEIGH.

It is to be noted that the right-hand member of equation (9) is LAPLACE'S equation transformed to cylindrical coördinates,

when the cylinder has circular symmetry. Thus we could have written:

$$\nabla^2 i = \frac{4\pi\mu}{\rho} \frac{\partial i}{\partial t} \quad (10)$$

Special Case.—Flat bar: Referring to Fig. 69, in the case of flat bar, r approaches infinity, and (9a) becomes:

$$\frac{4\pi\mu}{\rho} \frac{\partial i}{\partial t} = \frac{\partial^2 i}{\partial r^2} \quad (11)$$

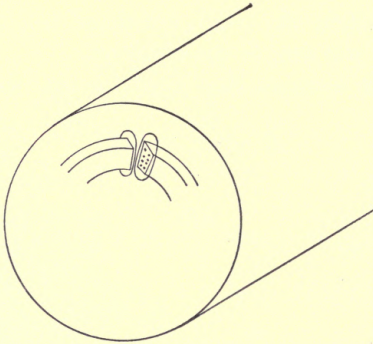

FIG. 143.

The distribution of flux in a cylindrical conductor surrounded by an energized solenoid is determined in a similar way. Fig. 143 shows the path of the current and flux. The dots represent the current, and the lines around the current, the flux.

The result for a cylinder is identical with equation (9), if H is substituted for i .

Similarly, for a flat bar equation (10) is applicable with the same substitutions.

CHAPTER XXV

MATHEMATICAL SOLUTION OF EQUATION 11, PAGE 267, DEALING WITH ALTERNATING CURRENT DISTRIBUTION IN CIRCULAR CYLINDRICAL CONDUCTOR

The general equation is as has been shown:

$$\frac{\partial^2 i}{\partial r^2} + \frac{1}{r} \frac{\partial i}{\partial r} = \frac{4\pi\mu}{\rho} \frac{\partial i}{\partial t} \quad (1)$$

Since we are dealing with sine waves, let:

$$i = i_1 \cos \omega t + i_2 \sin \omega t \quad (2)$$

where i_1 and i_2 , the current densities, are functions of r but not of t . Substitute first, $i = i_1 \cos \omega t$,

$$\frac{\partial i}{\partial r} = \cos \omega t \frac{\partial i_1}{\partial r},$$

$$\frac{\partial^2 i}{\partial r^2} = \cos \omega t \frac{\partial^2 i_1}{\partial r^2},$$

and,

$$\frac{\partial i}{\partial t} = -\omega i_1 \sin \omega t.$$

$$\therefore \cos \omega t \frac{\partial^2 i_1}{\partial r^2} + \frac{1}{r} \cos \omega t \frac{\partial i_1}{\partial r} = -\frac{4\pi\mu}{\rho} i_1 \omega \sin \omega t \quad (3)$$

Similarly, for $i = i_2 \sin \omega t$,

$$\sin \omega t \frac{\partial^2 i_2}{\partial r^2} + \frac{1}{r} \sin \omega t \frac{\partial i_2}{\partial r} = \frac{+4\pi\mu}{\rho} i_2 \omega \cos \omega t \quad (4)$$

Adding (3) and (4),

$$\therefore \cos \omega t \left[\frac{\partial^2 i_1}{\partial r^2} + \frac{1}{r} \frac{\partial i_1}{\partial r} - \frac{4\pi\mu\omega}{\rho} i_2 \right] + \sin \omega t \left[\frac{\partial^2 i_2}{\partial r^2} + \frac{1}{r} \frac{\partial i_2}{\partial r} + \frac{4\pi\mu\omega}{\rho} i_1 \right] = 0 \quad (5)$$

$$\therefore \frac{\partial^2 i_1}{\partial r^2} + \frac{1}{r} \frac{\partial i_1}{\partial r} = \frac{4\pi\mu\omega}{\rho} i_2 \quad (6)$$

and

$$\frac{\partial^2 i_2}{\partial r^2} + \frac{1}{r} \frac{\partial i_2}{\partial r} = -\frac{4\pi\mu\omega}{\rho} i_1 \quad (7)$$

Assume:

$$i_1 = a_0 + a_1r + a_2r^2 + a_3r^3 + \dots + a_nr^n + \dots \quad (8)$$

and

$$i_2 = b_0 + b_1r^1 + b_2r^2 + b_3r^3 + \dots + b_nr^n + \dots \quad (9)$$

Then:

$$\frac{\partial i_1}{\partial r} = a_1 + 2a_2r + 3a_3r^2 + \dots + na_nr^{n-1} + \dots \quad (10)$$

$$\frac{\partial^2 i_1}{\partial r^2} = 2a_2 + 6a_3r + \dots + n(n-1)a_nr^{n-2} + \dots \quad (11)$$

Let

$$m^2 = \frac{4\pi\mu\omega}{\rho} \quad (12)$$

(6) and (7) can be written:

$$r \frac{\partial^2 i_1}{\partial r^2} + \frac{\partial i_1}{\partial r} = m^2 r i_2 \quad (13)$$

and,

$$r \frac{\partial^2 i_2}{\partial r^2} + \frac{\partial i_2}{\partial r} = -m^2 r i_1 \quad (14)$$

Substituting (9), (10) and (11) in (13),

$$\left. \begin{aligned} &2a_2r + ba_3r^2 + \dots + n(n-1)a_nr^{n-1} + \dots \\ &+ a_1 + 2a_2r + 3a_3r^2 + \dots + na_nr^{n-1} + \dots \\ &= m^2(b_0r + b_1r^2 + b_2r^3 + \dots + nb_nr^{n-1} + \dots) \end{aligned} \right\} \quad (15)$$

$$\therefore a_1 = 0; 4a_2 = m^2b_0; 9a_3 = m^2b_1; \text{ in general, } n^2a_n = m^2b_{n-2} \quad (16)$$

By similar substitutions in (14), we have:

$$\left. \begin{aligned} &b_1 = 0; 4b_2 = -m^2a_0; 9b_3 = -m^2a_1; \text{ in general, } \\ &n^2b_n = -m^2a_{n-2}, \text{ or } (n-2)^2b_{n-2} = -m^2a_{n-4} \end{aligned} \right\} \quad (17)$$

Combining the last equations in (16) and (17),

$$a_n = -\frac{m^4}{n^2(n-2)^2} a_{n-4} \quad (18)$$

From (17),

$$b_n = -\frac{m^2}{n^2} a_{n-2} \quad (19)$$

Since $a_1 = 0$, and $b_1 = 0$, from (18) and (19) all the a 's and b 's with odd indices separately equal to zero. And those with even indices are as follows:

$a_0 = a_0$ $a_4 = -\frac{m^4}{2^2 \cdot 4^2} a_0$ $a_8 = -\frac{m^4}{6^2 \cdot 8^2} a_4 = +\frac{m^8}{2^2 \cdot 4^2 \cdot 6^2 \cdot 8^2} a_0$ and so forth	$a_2 = a_2$ $a_6 = -\frac{m^4}{4^2 \cdot 6^2} a_2$ $a_{10} = -\frac{m^4}{8^2 \cdot 10^2} a_6 = +\frac{m^8}{4^2 \cdot 6^2 \cdot 8^2 \cdot 10^2} a_2$ and so forth
$b_2 = -\frac{m^2}{2^2} a_0$ [see (19)] $b_6 = -\frac{m^2}{6^2} a_4 = +\frac{m^6}{2^2 \cdot 4^2 \cdot 6^2} a_0$ $b_{10} = -\frac{m^2}{(10)^2} a_8 = -\frac{m^{10}}{2^2 \cdot 4^2 \cdot 6^2 \cdot 8^2} a_0$ and so forth	$b_0 = +\frac{m^2}{2^2} a_2$ [See (16)] $b_4 = -\frac{m^2}{4^2} a_2$ $b_8 = -\frac{m^2}{8^2} a_6 = +\frac{m^6}{4^2 \cdot 6^2 \cdot 8^2} a_2$ $b_{12} = -\frac{m^2}{(12)^2} a_{10} =$ $-\frac{m^{10}}{4^2 \cdot 6^2 \cdot 8^2 \cdot (10)^2 \cdot (12)^2} a_2$ and so forth

Therefore, $i_1 = a_0 \left(1 - \frac{m^4 r^4}{2^2 \cdot 4^2} + \frac{m^8 r^8}{2^2 \cdot 4^2 \cdot 6^2 \cdot 8^2} - \dots \right)$
 $+ \frac{4}{m^2} a^2 \left(\frac{m^2 r^2}{2^2} - \frac{m^6 r^6}{2^2 \cdot 4^2 \cdot 6^2} + \frac{m^8 r^8}{2^2 \cdot 4^2 \cdot 6^2 \cdot 8^2 \cdot (10)^2} \dots \right)$ (20)

and

$$i_2 = -a_0 \left(\frac{m^2 r^2}{2^2} - \frac{m^6 r^6}{2^2 \cdot 4^2 \cdot 6^2} + \dots \right) + \frac{4}{m^2} a_2 \left(1 - \frac{m^4 r^4}{2^2 \cdot 4^2} + \dots \right)$$
 (21)

LORD KELVIN has denoted the first series in (20) by *ber* (*mr*) and the second in (20) by *bei* (*mr*), thus:

$$\left. \begin{aligned} ber(x) &= 1 - \frac{x^4}{2^2 \cdot 4^2} + \frac{x^8}{2^2 \cdot 4^2 \cdot 6^2 \cdot 8^2} - \dots, \text{ and} \\ bei(x) &= \frac{x^2}{2^2} - \frac{x^6}{2^2 \cdot 4^2 \cdot 6^2} + \frac{x^{10}}{2^2 \cdot 4^2 \cdot 6^2 \cdot 8^2 \cdot (10)^2} - \dots \end{aligned} \right\} \quad (22)$$

And

$$\left. \begin{aligned} i_1 &= a_0 ber(mr) + \frac{4}{m^2} a^2 bei(mr), \text{ and,} \\ i_2 &= -a_0 bei(mr) + \frac{4}{m^2} a^2 ber(mr) \end{aligned} \right\} \quad (23)$$

These functions, *ber* and *bei*, have been worked out and appear frequently in books on mathematical physics.

Therefore,

$$i = \left[a_0 \operatorname{ber}(mr) + \frac{4}{m^2} a^2 \operatorname{bei}(mr) \right] \cos \omega t + \left[\frac{4}{m^2} a_2 \operatorname{ber}(mr) - a_0 \operatorname{bei}(mr) \right] \sin \omega t \quad (24)$$

The constants a_0 and a_2 are determined from the fact that the extreme outside layer is not surrounded by any flux. (We consider only the flux in the wire in this calculation.) Thus the sine term is zero at all values of t .

Let I_0 = maximum value of the current density at the surface, then,

$$\left. \begin{aligned} I_0 &= a_0 \operatorname{ber}(mR) + \frac{4a_2}{m^2} \operatorname{bei}(mR), \\ O &= \frac{4a_2}{m^2} \operatorname{ber}(mR) - a_0 \operatorname{bei}(mR) \end{aligned} \right\} \quad (25)$$

Equations (25) are readily solved and give:

$$\left. \begin{aligned} \frac{4a_2}{m^2} &= \frac{I_0 \operatorname{bei}(mR)}{\operatorname{ber}^2(mR) + \operatorname{bei}^2(mR)}, \\ a_0 &= \frac{I_0 \operatorname{ber}(mR)}{\operatorname{ber}^2(mR) + \operatorname{bei}^2(mR)} \end{aligned} \right\} \quad (26)$$

$$\therefore i = \frac{I_0}{\operatorname{ber}^2(mR) + \operatorname{bei}^2(mR)} \{ [\operatorname{ber}(mR) \operatorname{ber}(mr) + \operatorname{bei}(mR) \operatorname{bei}(mr)] \cos \omega t + [\operatorname{bei}(mR) \operatorname{ber}(mr) - \operatorname{ber}(mR) \operatorname{bei}(mr)] \sin \omega t \} \quad (27)$$

Thus the square of the effective current density

$$\begin{aligned} &= i_{eff.}^2 = \frac{I_0^2}{2[(\operatorname{ber}^2(mR) + \operatorname{bei}^2(mR))]^2} [\operatorname{ber}^2(mR) \operatorname{ber}^2(mr) + \operatorname{ber}^2(mR) \operatorname{bei}^2(mr) + \operatorname{bei}^2(mR) \operatorname{bei}^2(mr) + \operatorname{bei}^2(mR) \operatorname{ber}^2(mr)] \\ &= \frac{I_0^2}{2[\operatorname{ber}^2(mR) + \operatorname{bei}^2(mR)]} [\operatorname{ber}^2(mr) + \operatorname{bei}^2(mr)]. \\ \therefore i_{eff.} &= \frac{I_0}{\sqrt{2}} \sqrt{\frac{\operatorname{ber}^2(mr) + \operatorname{bei}^2(mr)}{\operatorname{ber}^2(mR) + \operatorname{bei}^2(mR)}} \quad (28) \end{aligned}$$

At the center of the conductor, $r = 0$,

$$\therefore \operatorname{ber}(mr) = 1,$$

and,

$$\operatorname{bei}(mr) = 0.$$

$$\therefore i_{eff.} = \frac{I_0}{\sqrt{2}} \frac{1}{\sqrt{\operatorname{ber}^2(mR) + \operatorname{bei}^2(mR)}} \text{ at } r = 0.$$

With very low frequency, the current density approaches the direct current case where it is normal and is:

$$i_{eff} = \frac{I_0}{\sqrt{2}}$$

thus the ratio of the alternating current density at the center to that of the direct current is:

$$\frac{1}{\sqrt{ber^2(mR) + bei^2(mR)}}$$

For copper,

$$\mu = 1, \quad \rho = 1600,$$

$$\therefore m = \sqrt{\frac{4\pi 2\pi f}{1600}} = 0.222\sqrt{f}.$$

If the radius is 1 cm., and the frequency is 60,

$$mR = 1.72,$$

and,

$$[ber^2(mR) + bei^2(mR)]^{-1/2} = 0.87.$$

\therefore the current density at the center is 87 per cent. of that at the surface, and also 87 per cent. of what it would be with direct current.

If the conductor had a diameter of 50 cm., the current density at the center would only be 25 per cent. of that at the surface.

Actual watts consumed in heat are:

$$W_{act.} = \rho \int_0^R i_{eff.}^2 2\pi r dr = \frac{\pi \rho I_0^2 \int_0^R [ber^2(mr) + bei^2(mr)] d(r^2)}{2[ber^2(mR) + bei^2(mR)]} \quad (29)$$

$$W' = (\text{ohmic resistance}) \cdot (\text{total eff. current})^2 \quad (30)$$

$$\text{Ohmic resistance} = \frac{\rho}{\pi R^2} \quad (31)$$

Total current =

$$\int_0^R i 2\pi r dr = \frac{\pi I_0}{ber^2(mR) + bei^2(mR)} \left\{ \left[ber(mR) \int_0^R ber(mr) d(r^2) + bei(mR) \int_0^R bei(mr) d(r^2) \right] \cdot \cos \omega t + \left[bei(mR) \int_0^R ber(mr) d(r^2) - ber(mR) \int_0^R bei(mr) d(r^2) \right] \sin \omega t \right\}$$

$$\therefore (\text{total eff. current})^2 = \frac{\pi^2 I_0^2}{2[ber^2(mR) + bei^2(mR)] \left\{ \left[\int_0^R ber(mr) d(r^2) \right]^2 + \left[\int_0^R bei(mr) d(r^2) \right]^2 \right\}} \quad (32)$$

$$\therefore W' = \frac{\pi \rho I_0^2 \left\{ \left[\int_0^R ber (mr) d(r^2) \right]^2 + \left[\int_0^R bei (mr) d(r^2) \right]^2 \right\}}{2R^2 [ber^2 (mR) + bei^2 (mR)]} \quad (33)$$

The coefficient of skin effect =

$$K = \frac{W_{act.}}{W'} = \frac{\left[\int_0^R ber^2 (mr) d(r^2) + \int_0^R bei^2 (mr) d(r^2) \right] R^2}{\left[\int_0^R ber (mr) d(r^2) \right]^2 + \left[\int_0^R bei (mr) d(r^2) \right]^2} \quad (34)$$

$$ber (mr) = 1 - 156 \left(\frac{mr}{10} \right)^4 + 676 \left(\frac{mr}{10} \right)^8 - 470 \left(\frac{mr}{10} \right)^{12} + \dots$$

$$ber^2 (mr) = 1 - 312 \left(\frac{mr}{10} \right)^4 + 25,500 \left(\frac{mr}{10} \right)^8 - 210,100 \left(\frac{mr}{10} \right)^{12} + \dots$$

$$bei (mr) = 25 \left(\frac{mr}{10} \right)^2 - 433 \left(\frac{mr}{10} \right)^6 + 677 \left(\frac{mr}{10} \right)^{10} - \dots$$

$$bei^2 (mr) = 625 \left(\frac{mr}{10} \right)^4 - 21,650 \left(\frac{mr}{10} \right)^8 + 231,800 \left(\frac{mr}{10} \right)^{12} - \dots$$

$$ber^2 (mr) + bei^2 (mr) = 1 + 313 \left(\frac{mr}{10} \right)^4 + 3900 \left(\frac{mr}{10} \right)^8 + 21,700 \left(\frac{mr}{10} \right)^{12} + \dots$$

$$\int_0^R [ber^2 (mr) + bei^2 (mr)] d(r^2) = R^2 \left[1 + 104.2 \left(\frac{mR}{10} \right)^4 + 780 \left(\frac{mR}{10} \right)^8 + 3100 \left(\frac{mR}{10} \right)^{12} + \dots \right] \quad (35)$$

$$\int_0^R ber (mr) d(r^2)^2 + R^2 \left[1 - 52 \left(\frac{mR}{10} \right)^4 + 135.2 \left(\frac{mR}{10} \right)^8 - 67.1 \left(\frac{mR}{10} \right)^{12} + \dots \right]$$

$$\cdot \left[\int_0^R ber (mr) d(r^2) \right]^2 = R^4 \left[1 - 104 \left(\frac{mR}{10} \right)^4 + 2971 \left(\frac{mR}{10} \right)^8 - 14,220 \left(\frac{mR}{10} \right)^{12} + \dots \right] \quad (36)$$

$$\int_0^R bei (mr) d(r^2) = R^2 \left[12.5 \left(\frac{mR}{10} \right)^2 - 108.2 \left(\frac{mR}{10} \right)^6 + 112.8 \left(\frac{mR}{10} \right)^{10} - \dots \right]$$

$$\left[\int_0^R bei (mr) d(r^2) \right]^2 =$$

$$R^4 \left[156 \left(\frac{mR}{10} \right)^4 - 2705 \left(\frac{mR}{10} \right)^8 + 14.580 \left(\frac{mR}{10} \right)^{12} - \dots \right] \quad (37)$$

Substituting (35) (36) and (37) in (34),

$$K = \frac{1 + 104.3 \left(\frac{mR}{10} \right)^4 + 780 \left(\frac{mR}{10} \right)^8 + 3100 \left(\frac{mR}{10} \right)^{12} + \dots}{1 + 52 \left(\frac{mR}{10} \right)^4 + 266 \left(\frac{mR}{10} \right)^8 + 360 \left(\frac{mR}{10} \right)^{12} + \dots} \quad (38)$$

The following tables give the coefficient of skin effect at various values of mR and the values of m for copper, aluminium and iron.

mR	K	mR	K	mR	K
0	1	3.0	1.32	6.0	2.39
0.05	1.0001	3.5	1.49	8.0	3.10
1.0	1.005	4.0	1.68	10.0	3.79
1.5	1.026	4.5	1.86	15.0	5.57
2.0	1.08	5.0	2.04	20.0	7.32
2.5	1.17	5.5	2.22		

Material	μ	ρ in. e.m.u.	m
Copper.....	1	1700 at 20°C.	0.216 √f
Aluminium.....	1	3,000	0.162 √f
Iron.....	300 to 1200	10,000	0.09 √μf

The value of μ for iron is usually taken as 300, but experiments on iron wires used as transmission lines seem to give values of μ as high as 1200.

LORD RAYLEIGH has shown that when the penetration is so slight that the above table can not be used a close approximation of the "effective thickness" in centimeters of the surface layer which causes the current is:

$$\delta = \frac{1}{\sqrt{2\pi\mu K\omega}}$$

where K is the specific conductivity.

This formula becomes $\delta = \frac{6.6}{\sqrt{f}}$ for copper approximately.

$\delta = \frac{8.8}{\sqrt{f}}$ for aluminium approximately.

$\delta = \frac{16}{\sqrt{\mu f}}$ for steel approximately.

CHAPTER XXVI

ELECTROMAGNETIC RADIATION

Introduction.—The laws governing electromagnetic radiation were stated by MAXWELL fifty years ago. The experimental verification was presented twenty years later by HERTZ in a series of most extraordinary papers, which were later published in book form. The practical application was made by MARCONI.

An extensive literature is now available, notably FLEMING'S "The Principles of Electric Wave Telegraphy and Telephony," and ZENNECK'S "Wireless Telegraphy."

In writing this chapter the author has drawn extensively upon the information which is given in these books. Since it is likely that students who have not read what preceded this chapter will want to understand the principles of wireless transmission it has seemed wise to built up the theory from the fundamental laws even though this procedure necessarily involves some repetition of what has been given in previous chapters.

Fundamental Conceptions.—Surrounding any body charged with electricity is an electric field. The intensity of the field usually varies from point to point, but, at any point it is proportional to the charge, that is, the amount of electricity on the charged body.

To charge a body we connect it to a source of potential when a current momentarily flows from the source to the body, the current stopping when the potential of the body is the same as the potential of the source.

If i is the current flowing during an interval of time dt then the resulting charge on the body is $dq = idt$, or,

$$i = \frac{dq}{dt} \quad (1)$$

For reasons that will appear later, it has been assumed that the outward field of flux from a body charged with Q units of electricity is

$$\psi = 4\pi Q \text{ lines of electric force.}$$

If the lines are uniformly distributed over a closed envelope of area A sq. cm., then the density of the electric field is

$$= \frac{4\pi Q}{A} \quad (2)$$

By the introduction of the constant 4π in the flux formula this density becomes in space the same as the force in dynes per unit charge which is numerically the same as the intensity R of the electric field at the particular point considered. This is easily seen from COULOMB'S law, which states that the repulsive force between two charges Q and Q_1 is

$$f = \frac{QQ_1}{Kr^2}$$

where r is the distance between them and $V_1 = 1$.

In the ideal case the charge is confined to a point and the flux is distributed uniformly in every direction.

$$\therefore R = \frac{\psi}{\text{area of sphere}} = \frac{4\pi Q}{4\pi r^2} = \frac{Q}{r^2}$$

where r is the distance from the point to the point charge.

or,

$$Q = Rr^2$$

$$\therefore f = \frac{R}{r^2} r^2 Q_1 = RQ_1.$$

If, therefore, $Q_1 = 1$, $f = R$.

The potential difference between two points in an electric field is by definition numerically the same as the work done in moving unit charge from one point to the other.

Thus, if X represent the intensity of the electric field in a certain direction, say a direction parallel to the x -axis in a rectangular coördinate system, then the potential difference across a short element dx is $dV = Xdx$ = force on unit charge at distance x , or,

$$X = \frac{dV}{dx}.$$

Similarly

$$Y = \frac{dV}{dy}$$

and

$$Z = \frac{dV}{dz}.$$

Y and Z being, respectively, the electric intensities along, or parallel to, the x and y axes.

y z

If we desire to find the potential difference between the ends of a wire bent in a small rectangle in the x - y planes and the intensities along the x and y axes are X and X_1 , Y and Y_1 , then referring to Fig. 144,

$$dV = Xdx + Y_1dy - X_1dx - Ydy \quad (3)$$

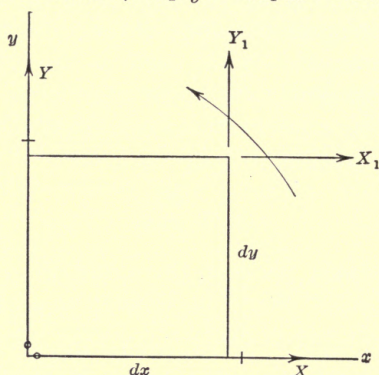

FIG. 144.

$$\text{For} \quad \begin{array}{ll} y = 0 & X = X \\ y = dy & X = X_1. \end{array}$$

The rate of change of X as we travel along the y -axis is $\frac{\partial X}{\partial y}$, thus the total change in distance dy is:

$$\frac{\partial X}{\partial y} dy$$

$$\therefore X_1 = X + \frac{\partial X}{\partial y} dy$$

Similarly,

$$Y_1 = Y + \frac{\partial Y}{\partial x} dx$$

(4)

Substituting (4) in (3) we get

$$\left(\frac{\partial Y}{\partial x} - \frac{\partial X}{\partial y} \right) dx dy = dV.$$

It is one of the properties of the electric field alone when free from charges that the above potential difference is zero in a closed circuit.

If, however, an e.m.f. is induced in the rectangular circuit by change of flux treading through the circuit, then we get:

$$\left(\frac{\partial Y}{\partial x} - \frac{\partial X}{\partial y} \right) dx dy = - \frac{d\phi}{dt} = - \frac{dN}{dt} dx dy$$

where N is the density of the magnetic field perpendicular to the plane of the electric circuit.

By a similar reasoning we get then the following three important equations:

$$\left. \begin{aligned} \frac{\partial Y}{\partial x} - \frac{\partial X}{\partial y} &= - \frac{dN}{dt} \\ \frac{\partial X}{\partial z} - \frac{\partial Z}{\partial x} &= - \frac{dM}{dt} \\ \frac{\partial Z}{\partial y} - \frac{\partial Y}{\partial z} &= - \frac{dL}{dt} \end{aligned} \right\} \quad (5)$$

where X, Y, Z, L, M, N , are respectively the electric intensities and magnetic intensities in the same system of units parallel to the x, y and z axes.

Note that in air the densities are the same as the intensities.

The next consideration is in relation to the magnetic effect of a current.

Let A , Fig. 145, represent the end view of a wire A carrying a certain current dI , perpendicular to the plane of the paper. Let the curved line be in the plane of the paper.

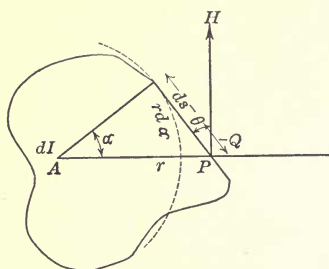

FIG. 145.

The magnetic field intensity at P is then H and this is defined similarly to R as numerically the same as the force on unit pole. Let, therefore, a pole of unit strength be carried along the curved path, Fig. 145. The work done per unit pole in completing the journey once is evidently

$$W = \int H \cos \theta ds = \int \frac{2dI}{r} \cos \theta ds$$

but

$$\frac{rd\alpha}{ds} = \cos \theta \quad \therefore ds = \frac{rd\alpha}{\cos \theta}$$

$$\therefore W = \int_{\alpha=0}^{\alpha=2\pi} 2dI d\alpha = 4\pi dI.$$

The work is independent of the position of the current element and the path. Thus if there are a number of filament currents *inside the path*,

$$\begin{aligned} I &= \Sigma dI \\ W &= 4\pi I \end{aligned} \quad (6)$$

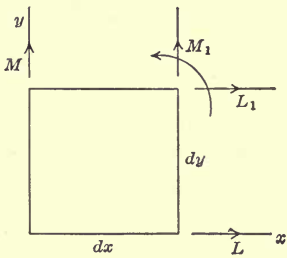

FIG. 146.

This quantity is by physicists called the magnetomotive force, around the circuit, whereas, engineers would call it $4\pi \times \text{m.m.f.}$

Consider now a small rectangular surface, Fig. 146, in the x - y plane of a magnetic field, and let L and L_1 , M and M_1 be the components of the magnetic field intensities, along the x and y axes respectively.

Then the line integral, or work on unit pole around the element is

$$Ldx + M_1dy - L_1dx - Mdy.$$

The rate of change of L as we travel along the y -axis is $\frac{\partial L}{\partial y}$, thus the total change is $\frac{\partial L}{\partial y} dy$, thus

$$L_1 = L + \frac{\partial L}{\partial y} dy.$$

Similarly

$$M_1 = M + \frac{\partial M}{\partial x} dx.$$

$$\therefore W = \frac{\partial M}{\partial x} dx dy - \frac{\partial L}{\partial y} dx dy = \left(\frac{\partial M}{\partial x} - \frac{\partial L}{\partial y} \right) dx dy.$$

From (6) it is seen that

$$\left(\frac{\partial M}{\partial x} - \frac{\partial L}{\partial y} \right) dx dy = 4\pi I_z \quad (7)$$

where I_z is the total current flowing through the rectangle perpendicular to $dx dy$.

Depending upon the medium, this current may be the ordinary conduction current such as flows in a wire or the charging current which is incident to a change in the electric field, or indeed, the sum of the two currents.

In this analysis it will be assumed that the air surrounding the oscillator is free from ionization, so that its resistance is infinite; thus the only currents considered are the "displacement, or charging currents."

MAXWELL assumed that surrounding a charged body is an electric field, the strength of which is proportional to the charge, and that the intensity of the field is a measure of what he calls

displaced electricity. The displacement of electricity is in the direction of the field intensity, and is thus a directed quantity. Numerically a charge Q displaces Q units of electricity outward from the body. Since $dQ = idt$, it follows that the displacement current or, as engineers say, the charging current is proportional to the time rate of change of the electric field intensity.

Or,

$$i = a \frac{dR}{dt}$$

where R is the intensity and a a constant to be determined.

MAXWELL worked out his theory on the basis that the displacement is numerically the same as the charge per unit area.

Thus

$$d = \sigma = \frac{Q}{\text{area}}$$

But the outward normal flux from a charge Q is $\psi = 4\pi Q$; thus the intensity of the field is

$$R = \frac{\psi}{\text{area}} = \frac{4\pi Q}{\text{area}},$$

$$\therefore R = 4\pi d \text{ or } d = \frac{R}{4\pi} \text{ in air.}$$

$$\therefore i = \frac{1}{4\pi} \frac{dR}{dt}$$

where i is the current per unit area or current density.

If, therefore, u , v and w are the components of the displacement current densities along the x , y and z axes and X , Y and Z , the components of the electric intensities then:

$$u = \frac{1}{4\pi} \frac{\partial X}{\partial t}, \quad v = \frac{1}{4\pi} \frac{\partial Y}{\partial t} \text{ and } w = \frac{1}{4\pi} \frac{\partial Z}{\partial t} \quad (8)$$

everything being given in electro-static units.

From (7) and (8) it is evident that one can write

$$\left(\frac{\partial M}{\partial x} - \frac{\partial L}{\partial y} \right) dx dy = 4\pi w dx dy = \frac{\partial Z}{\partial t} dx dy,$$

or,

$$\frac{\partial M}{\partial x} - \frac{\partial L}{\partial y} = \frac{\partial Z}{\partial t},$$

By a similar reasoning are obtained the following three relations.

$$\left. \begin{aligned} \frac{\partial N}{\partial y} - \frac{\partial M}{\partial z} &= \frac{\partial X}{\partial t} \\ \frac{\partial L}{z} - \frac{\partial N}{\partial x} &= \frac{\partial Y}{\partial t} \\ \frac{\partial M}{\partial x} - \frac{\partial L}{\partial y} &= \frac{\partial Z}{\partial t} \end{aligned} \right\} \quad (9)$$

everything being given in the same system of units.

The simplest form of oscillator, or rather that form which lends itself to the simplest mathematical treatment, is that used by HERTZ.

The oscillator consists of two large spheres separated by a considerable distance and connected by wires through the spark gap to the source of energy as shown in Fig. 147.

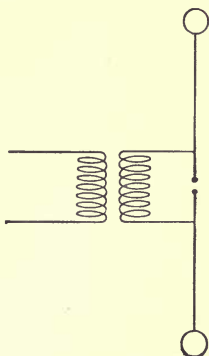

FIG. 147.

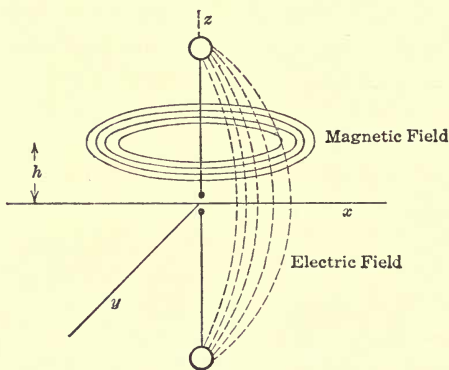

FIG. 148.

It will be assumed that the electric field is due to the spheres alone, and the magnetic field to the linear conductor.

It will be assumed that the axis of the oscillator is the z -axis. Thus the magnetic field which is in the form of rings around the conductor has, in the x - y plane, no component in the direction Z and therefore no e.m.f. can be induced in the x - y plane. However, e.m.fs. will be induced in the direction of the Z -axis.

Whatever the potential distribution in the x - y plane it must thus be due to the charges on the spheres alone, that is, due to the electric field alone.

The distribution of potential around an electric double, that is,

around two spheres given equal but opposite charges. Referring to Fig. 148, since

$$dV = -Rdr,$$

$$V = - \int Rdr = - \int \frac{Q}{r^2} dr = \frac{Q}{r}.$$

The potential at P is (Fig. 149):

$$V = \frac{q}{r_1} - \frac{q}{r_2} = q \left(\frac{1}{r_1} - \frac{1}{r_2} \right).$$

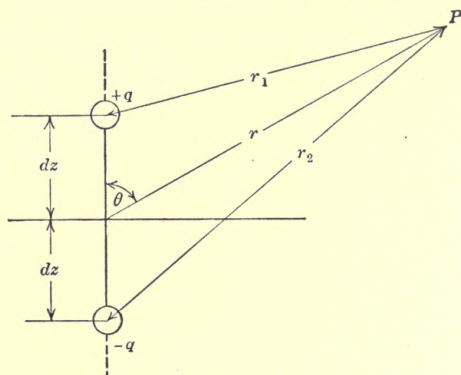

FIG. 149.

It is
$$V = 2 \frac{\partial}{\partial z} \left(\frac{q}{r} \right) dz \quad (10)$$

when r is large compared with dz (see note).

NOTE.—Proof:

$$\frac{\partial}{\partial z} \left(\frac{q}{r} \right) = \frac{\partial}{\partial z} \frac{q}{\sqrt{x^2 + y^2 + z^2}} = \frac{qz}{(x^2 + y^2 + z^2)^{3/2}} = \frac{q \cos \theta}{r^2}$$

and

$$q \left(\frac{1}{r_1} - \frac{1}{r_2} \right) = q \left(\frac{1}{\sqrt{x^2 + y^2 + (z - dz)^2}} - \frac{1}{\sqrt{x^2 + y^2 + (z + dz)^2}} \right)$$

by the use of the binomial theorem it is easily seen that this becomes:

$$\frac{2qdz \cos \theta}{r^2},$$

Equation (10) may be written

$$V = 2h \frac{\partial}{\partial z} \left(\frac{q}{r} \right) \quad (11)$$

where h , one-half of the length of the oscillator is substituted for dz .

NOTE.—Equation 11 is not limited to spheres but is quite general as long as the distances dealt with are long compared with the length of the oscil-

lator. Suppose, for instance, that we are dealing with a linear oscillator. We assume then that the potential at a point P can be expressed as due to two point charges located at some points on each rod (not the end of the oscillator) which will give the same potential as the linear conductor actually gives at distances far away from the oscillator. While this assumption is quite justified when dealing with points in space far away from the oscillator, it is obviously not at all permissible at points near the oscillator, because it is readily seen that the potential distribution at the surface of the two halves of the oscillator must be such that the surfaces themselves are equipotential surfaces and two point charges, no matter where located, can not give such equipotential surfaces. Fortunately, we are for practical purposes interested in only what happens far away from the oscillator, where equation 11 applies. The subsequent equations can indeed be used with such linear oscillator if instead of letting Q or I represent the charge and current respectively, we use the average value along the oscillator which is $\frac{2}{\pi} Q$ and $\frac{2}{\pi} I$. The ratio between λ the wave length and h the height of the sending antenna is in such case, theoretically 4, but in reality due to various effect nearer 4.8.

When P is far away from the oscillator the electric condition is not due to the instantaneous value of the charge q at the oscillator but due to the value of q which existed somewhat earlier in time.

Thus the charge causing the electric field at P is not $q = Q \sin \omega t$ but $q = Q \sin \omega(t - \Delta t)$ where Δt is the time required for the distribution to reach P .

If v is the velocity of the propagation which is that of light, then

$$v\Delta t = r \text{ or } \Delta t = \frac{r}{v}$$

$$\therefore q = Q \sin \left(\omega t - \frac{\omega r}{v} \right)$$

If λ is the wave length then

$$\lambda = vT = \frac{v}{f}$$

$$\therefore f = \frac{v}{\lambda}$$

$$\therefore q = Q \sin \left(\omega t - \frac{2\pi}{\lambda} r \right) = Q \sin (\omega t - mr) = -Q \sin (mr - \omega t)$$

$$\therefore V = -2Qh \frac{\partial}{\partial z} \frac{\sin (mr - \omega t)}{r} \quad (12)$$

$$\left. \begin{aligned} \therefore X &= -\frac{\partial V}{\partial x} = 2Qh \frac{\partial^2}{\partial x \partial z} \frac{\sin (mr - \omega t)}{r} \\ Y &= -\frac{\partial V}{\partial y} = 2Qh \frac{\partial^2}{\partial y \partial z} \frac{\sin (mr - \omega t)}{r} \end{aligned} \right\} \quad (13)$$

Z the component of the electric field intensity perpendicular to the x - y plane cannot be obtained from V alone as discussed above.

We shall now consider some of the properties of the magnetic field intensities.

Consider the x - y plane (Fig. 150).

It is obvious that since the lines of force are circles, the sum of the projections of the components of the magnetic field intensities along the x and y axes on a radius vector

must be zero. Let L and M be the components of H along the x and y axes. Since L itself is negative in the position shown, we have,

$$L \cos \alpha + M \sin \alpha = 0$$

but

$$\cos \alpha = \frac{x}{\rho}$$

and

$$\sin \alpha = \frac{y}{\rho}$$

$$\therefore Lx + My = 0,$$

or

$$\frac{L}{M} = -\frac{y}{x} \text{ but } x^2 + y^2 = \rho^2$$

$$\therefore xdx + ydy = 0.$$

Thus

$$\frac{L}{M} = \frac{dx}{dy}$$

or

$$Ldy - Mdx = 0 \tag{14}$$

This is satisfied as long as

$$L = \frac{\partial u}{\partial y} \text{ and } M = -\frac{\partial u}{\partial x} \tag{15}$$

where u is any function of x and y

N the component along the z -axis is obviously zero.

From equations (9) and (15)

$$\left. \begin{aligned} \frac{\partial X}{\partial t} &= \frac{\partial N}{\partial y} - \frac{\partial M}{\partial z} = \frac{\partial M}{\partial z} = \frac{\partial^2 u}{\partial x \partial z} \\ \frac{\partial Y}{\partial t} &= \frac{\partial L}{\partial z} - \frac{\partial N}{\partial x} = \frac{\partial L}{\partial z} = \frac{\partial^2 u}{\partial y \partial z} \\ \frac{\partial Z}{\partial t} &= \frac{\partial M}{\partial x} - \frac{\partial L}{\partial y} = -\left(\frac{\partial^2 u}{\partial x^2} + \frac{\partial^2 u}{\partial y^2}\right) \end{aligned} \right\} \tag{16}$$

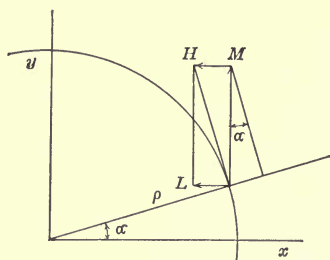

FIG. 150.

Referring now to (13) and differentiating X with respect to t

$$\frac{\partial X}{\partial t} = 2Qh \frac{\partial}{\partial t} \left(\frac{\partial^2}{\partial x \partial z} \frac{\sin (mr - \omega t)}{r} \right) \quad (17)$$

It is evident by comparing (16) and (17) that,

$$u = \frac{\partial}{\partial t} 2Qh \frac{\sin (mr - \omega t)}{r}.$$

Substituting this value in (16) we get:

$$\frac{\partial X}{\partial t} = \frac{\partial^3}{\partial t \partial x \partial z} \left(2Qh \frac{\sin (mr - \omega t)}{r} \right)$$

or

$$X = 2Qh \frac{\partial^2 \Pi}{\partial x \partial z}$$

$$Y = 2Qh \frac{\partial^2 \Pi}{\partial y \partial z}$$

$$Z = - 2Qh \left[\frac{\partial^2 \Pi}{\partial x^2} + \frac{\partial^2 \Pi}{\partial y^2} \right]$$

$$L = 2Qh \frac{\partial^2 \Pi}{\partial y \partial t}$$

$$M = - 2Qh \frac{\partial^2 \Pi}{\partial x \partial t}$$

$$N = 0$$

where

$$\Pi = \frac{\sin (mr - \omega t)}{r}.$$

It is now a simple matter to get the different derivatives of Π . An inspection of the several terms will readily show that some are much larger than others. There is little object in investigating conditions close to the oscillator by these equations even if all terms are used without considerable caution, because an approximation was made in the assumption that the electric field emanated from two point charges.

The derivatives contain trigonometric terms having coefficients of $m^2 r^2$, mr and unity.

The terms containing $m^2 r^2$ are so much larger than terms involving mr and unity that the latter can be neglected. Making these approximations and placing P in the x - z plane we get for distances involving several wave lengths,

$$\left. \begin{aligned} X &= -\frac{2Qhm^2}{r} \sin(mr - \omega t) \sin \theta \cos \theta \\ Y &= 0 \\ Z &= \frac{2Qhm^2}{r} \sin(mr - \omega t) \sin^2 \theta \dots \\ L &= 0 \end{aligned} \right\} \quad (19)$$

$$M = H = \frac{2Qhm\omega}{r} \sin(mr - \omega t) \sin \theta \quad (20)$$

Everything is given in electro-static units at present since all terms involve Q the charge which is expressed in such units.

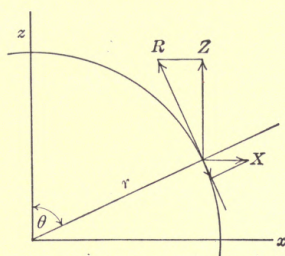

FIG. 151.

R the intensity along the surface of a sphere through r is (from Fig. 151):

$$R = Z \sin \theta - X \cos \theta = \frac{2Qhm^2}{r} \sin(mr - \omega t) \sin \theta (\sin^2 \theta + \cos^2 \theta)$$

$$\text{or} \quad R = \frac{2Qhm^2}{r} \sin(mr - \omega t) \sin \theta \quad (21)$$

It is of interest to compare equations (20) and (21)

since
$$m^2 = \frac{4\pi^2}{\lambda^2}$$

and
$$m\omega = \frac{2\pi}{\lambda} 2\pi f = \frac{4\pi^2}{\lambda^2}$$

We can write

$$H = R \quad (22)$$

when the charge is given in electro-static units.

The electric and magnetic intensities perpendicular to each other in space are in time phase. Thus the product of the two represents power. (This is the case only at some distance from the oscillator, near the oscillator the large part of the fields is in quadrature.)

It is remembered that in the ordinary electric circuit involving capacity and inductance the magnetic and electric field intensities are in time quadrature and, therefore, the product represents "wattless power or better reactive power."

Energy Radiated.—Equations (20) and (21) can be transformed to read,

$$\left. \begin{aligned} H &= \frac{2Ihm}{r} \sin (mr - \omega t) \sin \theta \\ \text{and} \\ R &= \frac{2I}{\omega} \frac{hm^2}{r} \sin (mr - \omega t) \sin \theta \end{aligned} \right\} \quad (22)$$

Since

$$\begin{aligned} q &= Q \sin (\omega t - mr) \text{ and } i = \frac{dq}{dt} = Q\omega \cos (\omega t - mr) \\ &= Q\omega \cos (mr - \omega t) \end{aligned}$$

$$\therefore I = Q\omega \text{ or } Q \frac{I}{\omega}.$$

If I is expressed in amperes and R in volts per centimeter, then

$$\left. \begin{aligned} H &= 0.2I \frac{hm}{r} \sin (mr - \omega t) \sin \theta \\ \text{and} \\ R &= 300 \times 10 \frac{2I}{\omega} \frac{Hm^2}{r} \sin (mr - \omega t) \sin \theta \end{aligned} \right\} \quad (23)$$

But

$$\left. \begin{aligned} m &= \frac{2\pi}{\lambda} \text{ and } \omega = 2\pi f = 2\pi \frac{V}{\lambda} \quad \therefore \\ \therefore H &= \frac{0.4\pi I}{r} \frac{h}{\lambda} \sin (mr - \omega t) \sin \theta \\ R &= \frac{120\pi I}{r} \frac{h}{\lambda} \sin (mr - \omega t) \sin \theta \end{aligned} \right\} \quad (24)$$

From what has been shown, it is remembered that H and R are perpendicular to each other in space.

The e.m.f. in a circuit is proportional to R , the current is proportional to H and the power to $HR \sin \alpha$ where α is the angle between H and R .

Since these fields are perpendicular to each other in space the energy radiated in time dt *eidt* is proportional to HR , or, $W = kHRdt$ and it remains to determine the value of k .

The voltage per centimeter is R ; thus $e = R$ when considering 1 cm. of circuit. The m.m.f. that produces a magnetic intensity H is $\frac{0.4\pi i}{l}$ where l is the length of the magnetic circuit in air.

$$\therefore i = \frac{Hl}{0.4\pi}$$

or, if we consider 1 cm. length of magnetic circuit,

$$i = \frac{H}{0.4\pi}$$

Thus the energy transmitted through a square centimeter area is:

$$W = eidt = \frac{RHdt}{0.4\pi}$$

Thus the energy radiated through the whole sphere of radius r enclosing the oscillator is (from Fig. 152):

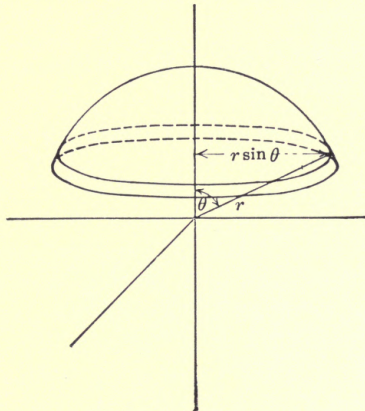

FIG. 152.

$$\begin{aligned} W &= \int_{\theta=0}^{\theta=\pi} \int_{r=0}^{r=T} \frac{RH}{0.4\pi} 2\pi r \sin \theta r d\theta dt \\ &= \int \int 240 \pi^2 \frac{h^2}{\lambda^2} I^2 \sin^2 (mr - \omega t) \sin^3 \theta d\theta dt \end{aligned} \quad (25)$$

but

$$\int_{\theta=0}^{\theta=T} \sin^2 (mr - \omega t) dt = \frac{T}{2} \text{ approximately}$$

and

$$\int_{\theta=0}^{\theta=\pi} \sin^3 \theta d\theta = \frac{4}{3}$$

$$\therefore W = 1600 \frac{h^2}{\lambda^2} I^2 T$$

$$\therefore \text{watts} = \frac{W}{T} = 1600 \frac{h^2}{\lambda^2} I^2.$$

If I is given in effective current then,

$$\text{watts} = 3200 \frac{h^2}{\lambda^2} I^2 \quad (26)$$

In the case of wireless transmission the radiated power corresponds to one-half of the area of the sphere thus,

$$\text{Watts} = 1600 \frac{h^2}{\lambda^2} I^2 \quad (27)$$

where I is the effective value of the current. The "Radiation" resistance is obviously

$$R = 1600 \frac{h^2}{\lambda^2} \quad (28)$$

It is noted that in the case of wireless telegraphy the energy radiated is greatest along the equatorial plane, that is, near the surface of the earth.

Since the receiving antenna is near the earth this result is, of course, very desirable.

MARCONI'S improvement upon HERTZ'S oscillator resulted from his connecting the lower end of his oscillator through a spark gap to ground, by which he was able not only to obtain the maximum energy, where it was most useful, but also to make use of half the length of oscillator for the same distribution of the magnetic and electric field above ground. This will be evident at once if it is considered that the earth being a perfect conductor, its surface is an equipotential surface.

It is easily proven from the equations given that the energy received near the surface of the earth through unit surface is 1.5 times the average value of the energy per unit surface.

It is also of interest to note that with an "ideal" simple antenna where $\lambda = 4h$ and the current is zero at the top at all times and therefore the average value of the current is $\frac{2}{\pi} I$ that the power radiated in watts is $40I_e^2$ or the radiation resistance is $R_r = 40$ ohms.

In this connection it is of interest to add that MAXWELL'S general equation of propagation of electromagnetic waves in space free from electric charges or magnets has been shown to be:

$$K\mu \frac{d^2u}{dt^2} = v^2 \left(\frac{\partial^2u}{\partial x^2} + \frac{\partial^2u}{\partial y^2} + \frac{\partial^2u}{\partial z^2} \right) = v^2 \nabla^2 u$$

where u is any of the components of the electric and magnetic intensities.

In the case of spherical waves it is readily proven by transforming the equation in spherical coördinates that any function of $r - vt$ divided by r satisfies the equation. Thus

$$\pi = \frac{1}{r} f(r - vt).$$

The function used so far was

$$\Pi = \frac{\sin (mr - \omega t)}{r}$$

which satisfies the above since $mr - \omega t = r - \frac{\omega t}{m} = m(r - vt)$.

In the case of sustained oscillations the function chosen was obviously most suitable. In the case of damped oscillations we would naturally choose

$$\pi = \frac{A}{r} e^{-\alpha(\omega t - mr)} \sin(mr - \omega t)$$

where A and α depend upon the amplitude and damping of the circuit.

Of special interest is the magnetic intensity H near the surface of the ground and the electric intensity R perpendicular to the surface but near the ground.

Equation (21) gives,

$$R = \frac{2Qhm^2}{r} \sin (mr - \omega t) \sin \theta = 2h \frac{I}{\omega} \frac{m^2}{r} \sin (mr - \omega t) \sin \theta = 4\pi \frac{v}{r} I \frac{h}{\lambda} \sin (mr - \omega t) \sin \theta$$

where I is expressed in electro-static units.

If the current be expressed in amperes and the potential gradient in volts per centimeter

$$R = \frac{4\pi I h}{V\lambda r} \times \frac{V}{10} \times 300 \sin (mr - \omega t) \sin \theta = 377 \frac{I}{r} \frac{h}{\lambda} \sin (mr - \omega t) \sin \theta \quad (29)$$

Thus the maximum value of the potential gradient near the surface of the ground is

$$R_{max.} = 377 \frac{I}{r} \frac{h}{\lambda} \text{ volts per cm.} \quad (30)$$

If, therefore, the height of the receiving antenna is h_1 cm. the maximum value of the potential difference between earth and top is

$$E_1 = \frac{377}{r} \frac{h}{\lambda} h_1 I$$

or the impedance of the receiving antenna is

$$\frac{Z}{2} = \frac{E_1}{I} = \frac{377}{r} \frac{h}{\lambda} h_1 \text{ ohms.} \quad (31)$$

and the effective value of the voltage is:

$$E_e = I_e Z_1 \quad (32)$$

where E_e is the effective value of the voltage across the receiving antenna and I_e is the effective current in the sending antenna. In a simple antenna the current is a maximum at the gap and is zero at the top. Thus the current is not uniform as is the case in the HERTZ oscillator.

The average value of the current is $\frac{2}{\pi} I$. With such simple antenna the wave length λ should be $4h$ if there were no disturbing effects.

Substituting these values we get as the impedance of the receiving antenna in an ideal simple antenna

$$Z'_1 = 60 \frac{h_1}{r} \text{ ohms} \quad (33)$$

The magnetic field intensity H (equation 10) is similarly modified to

$$H = 2 \frac{I}{\omega} \frac{m\omega}{h} \frac{r}{r} \sin(mr - \omega t) \sin \theta = \frac{4\pi I}{r} \frac{h}{\lambda} \sin(mr - \omega t) \sin \theta$$

where I is in abamperes, or if I is expressed in amperes rather than abamperes

$$H = \frac{0.4\pi I}{r} \frac{h}{\lambda} \sin(mr - \omega t) \sin \theta \quad (34)$$

It is of interest to note that this agrees with the intensity due to an infinitely long conductor if

$$\frac{h}{\lambda} = \frac{1}{2\pi}$$

If the sending antenna were a simple rod then the current at the top would always be zero and the average value of the current would be $\frac{2}{\pi} I$. In that case the wave length would be $4h$.

Substituting these values we get:

$$H = \frac{0.2I}{r} \sin (mr - \omega t)$$

near the surface of the earth.

Thus the approximation sometimes made in writing

$$H = \frac{0.2I}{r} \sin(mr - \omega t) \sin \theta$$

is not very far from right—and is correct in the case of an “ideal simple antenna.”

It should again be emphasized that equations (29) and (34) give the values of the electric and the magnetic intensities several wave lengths away from the oscillator.

It can very readily be proven by carrying out the differentiations in equation (18) that near the oscillator the magnetic intensity decreases inversely as the square of the distance and the electric intensity inversely as the cube of the distance.

Power Factor and Logarithmic Decrement.—Prior to the use of high-frequency alternators for the production of radiation the trains of waves were oscillating, with decaying current and e.m.f. in the antenna and the word decrement had therefore a very significant meaning.

When alternators or oscillating arcs are used the current and the e.m.f. at the antenna are sustained, and therefore “decrement” ceases to have any meaning.

It is, therefore, appropriate to discuss the power factor rather than to try to treat of the decrement in such circuits.

If R_0 is the sum of the radiation resistance and the effective resistance of the wires and the ground connection, then the power consumed in the circuit is $P = I^2 R_0$, where I is the effective current. If E is the effective voltage, then

$$Pf = \frac{I^2 R_0}{IE} = R_0 \frac{I}{E}$$

but

$$I = 2\pi f C E = \omega C E \text{ where } C \text{ is given in farads,}$$

thus

$$Pf = \omega C R_0 \tag{35}$$

Numerical application:

Let $C = 003 \text{ m-f.} = \frac{3}{10^9} \text{ farads.}$

$$h = 50 \text{ m.}$$

$$\lambda = 3000 \text{ m.}$$

\therefore Radiation resistance = $1600 \left(\frac{50}{3000} \right)^2 = 0.5 \text{ ohm}$ approximately

$$\omega = 2\pi f = 2\pi \frac{V}{\lambda} = 2\pi 10^5.$$

Let the effective resistance of the wires and ground be 2 ohms, then

$$R_0 = 2.5 \text{ ohms.}$$

$$\therefore Pf = 2\pi 10^5 \frac{3}{10^9} 2.5 = 0.0047$$

or approximately one-half of 1 per cent.

The radiated energy corresponds in this case of course to only one-fifth of this amount.

The product of the current and the e.m.f. is 200 times as great as the power consumed in heat and radiations and 1000 times as great as the power radiated.

Determination of the "Logarithmic Decrement."—If a condenser is discharged in a circuit of negligible resistance an alternating current will flow indefinitely, and no energy will be expended since the energy is transferred alternately between the magnetic and the electric field.

When the current is a maximum (either positive or negative) the e.m.f. across the condenser is zero; when on the other hand the current is zero, the e.m.f. is a maximum.

Thus twice in each cycle the magnetic energy

$$W_m = \frac{1}{2}LI^2$$

is transferred to electric energy

$$W_e = \frac{1}{2}CE^2$$

The total amount of energy in joules surging during a cycle is then

$$W = LI^2 \text{ where } I \text{ is the maximum value of the current,}$$

or,

$$W = CE^2 \text{ where } E \text{ is the maximum value of the voltage.}$$

If, however, the circuit contains resistance, the current will not alternate indefinitely but will die down gradually, the rate of decay being greater the greater the energy consumption. During these oscillations energy is also transferred between the electric and magnetic field but each pulse of energy is smaller, than the preceding by the loss of energy in the resistance.

Ultimately all energy stored in the condenser becomes dissipated in heat or radiated away.

The energy stored in a condenser is $\frac{1}{2}CE^2$ joules where E is the voltage and C the capacity in farads. Thus if the condenser is charged and discharged N times per sec. the sum of the energy converted to heat and radiated away is $\frac{N}{2}CE^2$ joules per sec. or watts.

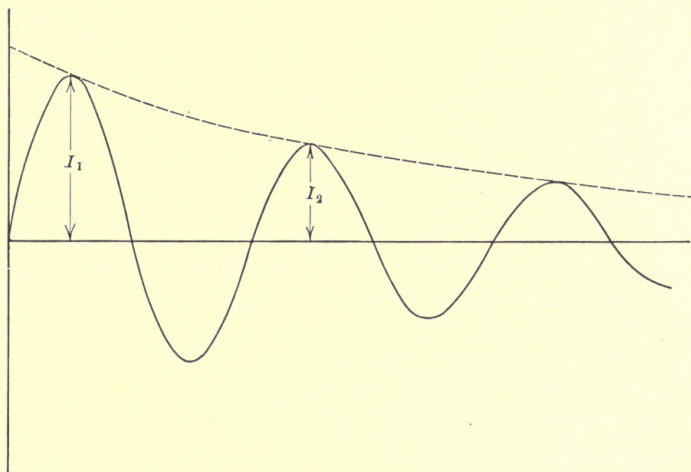

FIG. 153.

Thus

$$W_1 = \frac{N}{2}CE^2 \text{ watts} \quad (36)$$

In a circuit of concentrated inductance and capacity it is shown in the elementary theory of alternating current that the oscillating current can be expressed quite accurately by the following equation:

$$i = Ie^{-\alpha t} \sin \omega t.$$

Where $\alpha = \frac{R_0}{2L}$ and R_0 and L are assumed constants which however is not the case in ironclad inductors and in arcs.

The ratio $\frac{I_1}{I_2}$ is $\epsilon^{\frac{R_0}{2L} T}$

as is readily proven.

The logarithmic decrement is

$$\delta = \log \frac{I_1}{I_2} = \frac{R_0 T}{2L} \quad (37)$$

Incidentally δ is also the ratio between the energy absorbed by the resistance and the surging energy per cycle.

Thus
$$\delta = \frac{I^2 R_0 T}{2} \div LI^2 = \frac{R_0 T}{2L}$$

which agrees with (37).

In the case of the HERTZ oscillator or the umbrella type of antenna the inductance is confined largely to the linear conductor and the capacity to the spheres or superstructure; thus we may consider the inductance and capacity as separated rather than distributed, thus

$$f = \frac{1}{T} = \frac{1}{2\pi\sqrt{LC}} \quad (38)$$

$$\therefore \delta = \frac{R_0}{2L} 2\pi\sqrt{LC} = \pi R_0 \sqrt{\frac{C}{L}} \quad (39)$$

The resistance in the above formula is the sum of the radiation resistance, the resistance of the wires (taking into consideration the skin effect), the ground and the radiation resistance.

When an arc is used the resistance of the arc should also enter. Unfortunately the latter is not a constant but depends upon the current carried, and hence the decrement is not logarithmic. However, for the purpose of this article the arc resistance may be assumed constant at say 5 ohms. For a very complete discussion of this whole subject the reader is referred to FLEMMING'S "Principles of Electric Wave Telegraphy."

Equation 39 contains the inductance and capacity as well as the resistance. The inductance is usually very difficult to determine since at different wave lengths more or less inductance is added to that of the antenna proper. The capacity of the antenna is however, usually not changed but it depends upon the construction of the aerial. The complexity of the structure is, however, such that its value can hardly be calculated except in the very simplest cases—rarely used in practice.

FLEMMING expresses the approximate capacity of a vertical wire of radius, h cm. long as:

$$C_v = \frac{h}{2 \log \frac{h}{r} \times 9 \times 10^{11}} \text{ farads,}$$

when, as is the case in wireless stations the lower end of the wire is near ground, the capacity may, however, be say 10 per cent. greater.

He also expresses the capacity of a horizontal wire placed h_1 above ground as

$$C_h = \frac{l}{2 \log \frac{2h_1}{r} \times 9 \times 10^{11}}$$

where l is the length in centimeters and h the height above ground.

Thus the capacity of a T -shaped antenna may be approximated as:

$$C = C_v + C_h$$

obviously the total capacity is not at all proportional to the number of wires connected in multiple. It is only slightly increased as the number of wires is increased.

If the value of the capacity is difficult to calculate accurately it is measured relatively easily and will therefore be assumed as known. It ranges according to ZENNECK approximately as follows:

- 0.001 m-f. in torpedo boat antenna.
- 0.002 m-f. in battleship antenna.
- 0.007 m-f. in BRANTROCK station.
- 0.18 m-f. in NAUEN high-power station.

The capacity of the antenna of the experimental installation at Union College is 0.0012 m-f.

When the wave length is considerably more than four times the height of the antenna the current distribution is fairly uniform in the conductor, and, the circuit can be treated as consisting of "bunched" rather than distributed inductance and capacity when the following relation obtains.

$$T = 2\pi\sqrt{LC} \quad \therefore L = \frac{T^2}{4\pi^2 C}$$

thus

$$\sqrt{\frac{C}{L}} = \frac{2\pi C}{T}$$

$$\therefore \delta = \pi R_0 \sqrt{\frac{C}{L}} = \frac{2\pi^2 R_0 C}{T} = 2\pi^2 R_0 C \frac{v}{\lambda} \quad (40)$$

Numerical application: Union College station with an antenna having a capacity of 0.0012 m-f. sending out waves of 700 m. length. Assume $R_0 = 10$ ohms. (By far the greater part of this is the ground and spark resistance.)

Then

$$\delta = 2\pi^2 10 \frac{12}{10^{10}} \frac{3 \times 10^{10}}{70,000} = 0.103.$$

In the case of the simple antenna it has been shown that the radiation resistance assuming $\lambda = 4h$ and $I_{avg.} = \frac{2}{\pi} I$ is 40 ohms.

Thus the radiation decrement is:

$$\delta = 2\pi^2 40 \frac{h}{2 \log \frac{h}{r}} \frac{3 \times 10^{10}}{9 \times 10^{10}} = \frac{3.33}{\log \frac{h}{r}}$$

In reality due to the proximity of the earth and other causes the wave length is nearer 4.8 than four times the antenna height, and the average value of the current is nearer 0.7 and $\frac{2}{\pi}$.

Substituting these values we get:

$$R = 34 \text{ ohms instead of } 40 \text{ ohms}$$

and the radiation decrement for the simple antenna is:

$$\delta = \frac{2\pi^2 34}{2 \log \frac{h}{r}} \frac{3 \times 10^{10}}{9 \times 10^{11}} \frac{h}{\lambda} = \frac{2.35}{\log \frac{h}{r}} \quad (41)$$

Abraham gives

$$\delta = \frac{2.45}{\log \frac{h}{r}}$$

General Conclusions.—Since the power radiated from an antenna is:

$$W = 1600 \frac{h^2}{\lambda^2} I^2$$

it is evident that at a given voltage as the capacity of the superstructure is increased the current and the wave length are increased. Since, however, the energy is proportional to the square

of the current and the wave length is proportional to \sqrt{C} it follows that by adding capacity to the superstructure and therefore increasing the wave length the radiated energy is increased.

Therefore, if the capacity is made four times as great, the current² is 16 times as great and λ^2 is only four times as great, and hence, the radiated energy for the same antenna height is increased four-fold.

Unfortunately, however, there is hardly a practical way of increasing the top capacity without decreasing the effective height so that the gain is not as great as indicated and if the umbrella is carried to an extreme, the effective height may be so much decreased that the energy radiated may eventually begin to decrease.

With a given construction of the antenna the wave length may be increased by the introduction of inductance. In this case the energy radiated is, however, reduced.

It is noted that for a given current the radiated power is greater the higher the frequency. This does, however, not necessarily mean that the power received is greater, since as will be shown later the absorption of energy in space is much greater with short wave length than with long.

At times it is necessary to send at two widely different frequencies. The natural wave length may be say 600 m. and it is desired to communicate at a wave length of 300 m. In that case a condenser may be connected in the series with the antenna. Since two condensers in series have a smaller capacity than each and thus the frequency is increased.

The relation between the effective value of the antenna current and the maximum instantaneous value of the current and e.m.f.

If the damping is not excessive the discharge current of a condenser of voltage E can be represented by the following equation:

$$\left. \begin{aligned} i &= E\omega C e^{-\frac{R_0}{2L}\omega t} \sin \omega t \\ &= I e^{-\alpha t} \sin \omega t \end{aligned} \right\} \quad (42)$$

where

$$I = E\omega C \text{ and } \alpha = \frac{R_0}{2L} = \frac{\delta}{T}$$

R_0 being the total resistance in the circuit which is assumed constant, not depending upon the current.

The rate at which energy is being converted to heat and radiated is then:

$$R_0 I^2 \epsilon^{-2\alpha t} \sin^2 \omega t.$$

The energy developed in one train of waves then is,

$$\int_0^\infty R_0 I^2 \epsilon^{-2\alpha t} \sin^2 \omega t dt = \frac{I^2 R_0}{4\delta f} \text{ approximately} \quad (43)$$

If the antenna is charged and discharged N times per sec. then the power is

$$W = N \frac{I^2 R_0}{4\delta f} \quad (44)$$

If I_c is the effective value of the antenna current as read by a hot-wire instrument,

then

$$I_c^2 R_0 = N \frac{I^2 R_0}{4\delta f}$$

$$\therefore I = I_c \sqrt{\frac{4\delta f}{N}} \quad (45)$$

and since

$$E = \frac{I}{\omega C}$$

$$E = \frac{I_c}{\omega C} \sqrt{\frac{4\delta f}{N}} \quad (46)$$

Substituting

$$\delta = \frac{R_0}{2L} T$$

and

$$L = \frac{1}{\omega^2 C}$$

we get

$$\left. \begin{aligned} I &= I_c \epsilon \omega \sqrt{\frac{2R_0 C}{N}} \\ E &= \frac{I_c \epsilon}{C} \sqrt{\frac{2R_0 C}{N}} \end{aligned} \right\} \quad (47)$$

These equations connect the instantaneous max. values of the antenna current and e.m.f. with the effective current read by a hot-wire instrument.

Numerical application: At the Union College station $R_0 = 10$, $\lambda = 700$ m., $C = \frac{12}{10^{10}}$, $N = 500$. Using the small sending set.

$$I_c = 2.5 \text{ amp.}$$

$$f = \frac{3 \times 10^{10}}{70,000} = 0.43 \times 10^6$$

$$\therefore I = 2.5 \cdot 2\pi \cdot 43 \cdot 10^6 \sqrt{\frac{2 \times 10}{500}} \times \frac{12}{10^{10}} = 46 \text{ amp.}$$

$$E = 14,400 \text{ volts.}$$

Relation between E.m.fs. Frequencies and Coupling in Inductively Connected Circuits.—Let e_1 in Fig. 154 be the voltage across the primary capacity, e_2 in Fig. 154 be the voltage across the secondary capacity.

Then neglecting resistance we get:

$$\left. \begin{aligned} e_1 + L_1 \frac{di_1}{dt} + M \frac{di_2}{dt} &= 0 \\ e_2 + L_2 \frac{di_2}{dt} + M \frac{di_1}{dt} &= 0 \end{aligned} \right\} \quad (1)$$

but,

$$\left. \begin{aligned} i_1 &= C_1 \frac{de_1}{dt} \\ \therefore \frac{di_1}{dt} &= C_1 \frac{d^2e_1}{dt^2} \\ i_2 &= C_2 \frac{de_2}{dt} \end{aligned} \right\} \quad (2)$$

and

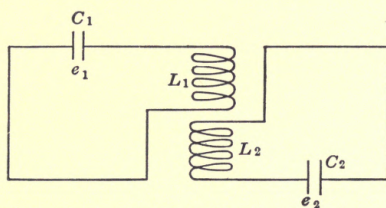

FIG. 154.

Substituting the current values of equation (2) and equation (1), and writing

$$\begin{aligned} e_1 &= E_1 \sin \omega t \\ e_2 &= E_2 \sin (\omega t + \alpha). \end{aligned}$$

Thus

$$\begin{aligned} \frac{d^2e_1}{dt^2} &= -E_1 \omega^2 \sin \omega t = -\omega^2 e_1 \\ \frac{d^2e_2}{dt^2} &= -\omega^2 e_2 \end{aligned}$$

we get,

$$e_1 - L_1 C_1 \omega^2 e_1 - M C_2 \omega^2 e_2 = 0 \quad (3)$$

$$e_2 - L_2 C_2 \omega^2 e_2 - M C_1 \omega^2 e_1 = 0 \quad (4)$$

From (3)

$$e_1 = \frac{MC_2\omega^2 e_2}{1 - L_1C_1\omega^2} \quad (5)$$

Substitute (5) in (4) and assume that $C_1L_1 = C_2L_2 = CL$, that is, assuming that the circuits when independent are tuned to the same wave lengths, then,

$$1 - 2LC\omega^2 - \omega^4(L^2C^2 - M^2C_1C_2) = 0$$

$$\therefore \omega^2 = \frac{1 \pm k}{CL(1 - k^2)} \quad (6)$$

where

$$k = \frac{M}{\sqrt{L_1L_2}}$$

$$\therefore f = \frac{1}{2\pi LC} \sqrt{\frac{1 \pm k}{1 - k^2}} = f_0 \sqrt{\frac{1 \pm k}{1 - k^2}} \quad (7)$$

or,

$$\left. \begin{aligned} f_1 &= f_0 \frac{1}{\sqrt{1 - k}} \\ f_2 &= f_0 \frac{1}{\sqrt{1 + k}} \end{aligned} \right\} \quad (8)$$

where f_0 is the frequency of each circuit when alone.

It is seen from these equations that two frequencies exist in the circuit and that they become nearer and nearer alike as the coefficient of coupling is decreased, that is the less the value of the mutual induction as compared with the self-induction.

In the case of transformation by ordinary transformer where the mutual induction is almost perfect, only one frequency will appear, namely, f_2 the forced frequency which in that case is $f_2 = f_0 \frac{1}{\sqrt{2}}$. In other words the radiated frequency has only one value and that value is 70 per cent. of that of each circuit when alone.

Since

$$\frac{f_1}{f_2} = \frac{\lambda_2}{\lambda_1}$$

It follows that two different wave lengths are transmitted and that

$$\frac{\lambda_1}{\lambda_2} = \sqrt{\frac{1 - k}{1 + k}} \quad (9)$$

Wave meters are used to show the wave length, and hence, if the wave length is known the coefficient of coupling can be determined, it is:

$$k = \frac{\lambda_2^2 - \lambda_1^2}{\lambda_2^2 + \lambda_1^2} \quad (10)$$

It is evident from the above that the current and voltage in two such circuits must be expressed as functions of two frequencies.

$$\text{Let } \left. \begin{aligned} e_1 &= A_1 \cos \omega_1 t + B_1 \omega_2 t \\ e_2 &= A_2 \cos \omega_1 t + B_2 \cos \omega_2 t \end{aligned} \right\} \quad (11)$$

These equations are justified since the resistance is negligible, and hence, no appreciable phase displacements exist between the two voltages.

$$\begin{aligned} &\text{For} \\ &\text{and} \end{aligned} \left\{ \begin{aligned} t &= 0, \\ e_1 &= E_1, \\ e_2 &= 0. \\ \therefore E_1 &= A_1 + B_1 \\ 0 &= A_2 + B_2 \end{aligned} \right\} \quad (12)$$

Consider then the two waves separately.

We have from (5)

$$\begin{aligned} &\text{and} \\ &\text{and} \end{aligned} \left\{ \begin{aligned} \frac{e_1}{e_2} &= \frac{MC_2\omega_1^2}{1 - L_1C_1\omega_1^2} = \frac{A_1}{A_2} = \alpha \\ \frac{e_1}{e_2} &= \frac{MC_2\omega_2^2}{1 - L_1C_1\omega_2^2} = \frac{B_1}{B_2} = \beta \end{aligned} \right\} \quad (13)$$

where

$$\begin{aligned} \alpha &= \frac{MC_2\omega_1^2}{1 - L_1C_1\omega_1^2} \\ \beta &= \frac{MC_2\omega_2^2}{1 - L_1C_1\omega_2^2} \end{aligned}$$

Thus from (12)

$$\begin{aligned} A_1 &= E_1 - B_1 \\ A_2 &= -B_2 \end{aligned}$$

$$\therefore \frac{A_1}{A_2} = -\frac{E_1 - B_1}{B_2} = \alpha \quad \therefore B_2 = -\frac{(E_1 - B_1)}{\alpha}$$

$$\begin{aligned} &\text{and} \\ &\text{and} \end{aligned} \left\{ \begin{aligned} \therefore \frac{B_1}{B_2} &= -\frac{\alpha B_1}{E_1 - B_1} = \beta \quad \therefore B_1 = \frac{\beta E_1}{\beta - \alpha} \\ A_1 &= E_1 - B_1 \quad \therefore A_1 = -\frac{\alpha E_1}{\beta - \alpha} \end{aligned} \right\} \quad (14)$$

$$\left. \begin{array}{l} \text{But} \\ \text{and} \end{array} \right\} \begin{array}{l} A_2 = \frac{A_1}{\alpha} \quad \therefore A_2 = \frac{E_1}{\beta - \alpha} \\ B_2 = -A_2 \quad \therefore B_2 = -\frac{E_1}{\beta - \alpha} \end{array} \quad (15)$$

\therefore Substituting these values in equation (11)

$$e_2 = \frac{E_1}{\beta - \alpha} [\cos \omega_1 t - \cos \omega_2 t]$$

Thus

$$\frac{E_2}{E_1} = \frac{1}{\beta - \alpha} \quad (16)$$

From (13)

$$\begin{aligned} \beta - \alpha &= MC_2 \left(\frac{\omega_2^2}{1 - L_1 C_1 \omega_2^2} - \frac{\omega_1^2}{1 - L_1 C_1 \omega_1^2} \right) \\ &= MC_2 \frac{(\omega_2^2 - \omega_1^2)}{1 - L_1 C_1 (\omega_1^2 + \omega_2^2) + L_1^2 C_1^2 \omega_1^2 \omega_2^2} \end{aligned}$$

from (6)

$$\omega_2^2 - \omega_1^2 = -\frac{2k}{C_1 L_1 (1 - k^2)}$$

$$\omega_2^2 + \omega_1^2 = \frac{\lambda}{C_1^2 L_1^2 (1 - k^2)}$$

$$\begin{aligned} \beta - \alpha &= \frac{2MC_2}{kC_1 L_1} = 2 \frac{C_2}{C_1} = \sqrt{\frac{L_2}{L_1}} = 2 \sqrt{\frac{C_2}{C_1}} \frac{\sqrt{C_2 L_2}}{\sqrt{C_1 L_1}} = 2 \sqrt{\frac{C_2}{C_1}} \\ \therefore \frac{E_2}{E_1} &= \frac{1}{2} \sqrt{\frac{C_1}{C_2}} \end{aligned} \quad (16)$$

Equation (16) shows the relation between the maximum voltage and the capacity when the circuits have negligible resistance.

When damped oscillations are considered the equations become more involved.

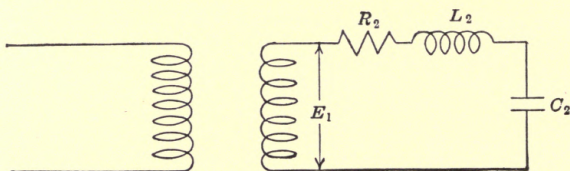

FIG. 155.

Consider the simplest case when the primary of the exciting transformer, Fig. 155, is supplied with power from an alternator or other source of sustained oscillations.

Due to the mutual induction between the primary and second-

ary circuits an e.m.f. $E_1 \sin \omega_1 t$ will be impressed upon the secondary.

The differential equation of the secondary circuit is thus:

$$E_1 \sin \omega_1 t = iR_2 + L_2 \frac{di}{dt} + e_2$$

where e_2 is the voltage across the secondary condenser.

But

$$i = C_2 \frac{de_2}{dt}$$

$$\therefore E_1 \sin \omega_1 t = C_2 R_2 \frac{de_2}{dt} + C_2 L_2 \frac{d^2 e_2}{dt^2} + e_2 \quad (1)$$

The sine term can be eliminated by two successive differentiations and the result will be a well-known linear differential equation of the fourth order the solution of which is:

$$e_2 = E_1 \sin (\omega_1 t + \varphi) + E' \epsilon^{-\alpha t} \sin (\omega_2 t + \psi) \quad (2)$$

The first term shows the value of the permanent voltage of the secondary circuit—of primary frequency, the second that of the transient which very soon ceases to exist.

Thus, if it is desired to study the constants of the antenna the transient term may be neglected and the permanent voltage becomes

$$e_2 = E \sin (\omega_1 t + \varphi).$$

Substituting this value in the differential equation we get after some simple transformations the following relation between the maximum value of the secondary voltage and the induced voltage.

$$E_2 = \frac{(\omega_2^2 + \alpha_2^2) E_1}{\sqrt{(\omega_1^2 - \omega_2^2 - \alpha_2^2)^2 + (2\omega_1 \alpha_2)^2}} \quad (3)$$

The secondary frequency

$$f_2 = \frac{1}{2\pi \sqrt{L_2 C_2}}$$

when the circuit contains no resistance and

$$f_2 = \frac{1}{2\pi} \sqrt{\frac{1}{C_2 L_2} - \left(\frac{R_2}{2L_2}\right)^2}$$

when the resistance is R_2

Thus

$$(2\pi f_2)^2 = \frac{1}{C_2 L_2} - \alpha_2^2$$

or

$$\frac{1}{C_2 L_2} = \omega_2^2 + \alpha_2^2$$

where

$$\alpha_2 = \frac{R_2}{2L_2}$$

$$I_2 = 2\pi f_1 C_2 E_2 = \omega_1 C_2 E_2$$

$$\therefore I_2 = \frac{\omega_1 E_1}{L_2(\omega_1^2 - \omega_2^2 - \alpha)^2 + (2\omega_1\alpha_2)^2} \quad (4)$$

When the secondary circuit has the same natural period as the primary impressed frequency the secondary current becomes a maximum.

Thus for

$$\omega_2 = \omega_1 \quad I = I_r$$

$$\therefore I_r = \frac{\omega_1 E_1}{L_2 \sqrt{\alpha_2^4 + 4\omega_1^2 \alpha_2^2}} = \frac{E_1}{2\alpha_2 L_2}$$

since α_2^4 is very small compared with $4\omega_1^2 \alpha_2^2$.

This is readily shown to be

$$I_r = \frac{E_1}{R_2} = \frac{E_1}{2L_2 f^2 \delta_2}$$

\therefore The square of the effective value of the secondary currents is

$$J_r^2 = \frac{E_1^2}{8f^2 L_2^2 \delta_2^2} \quad (5)$$

$$\therefore \frac{I}{I_r} = \frac{2\alpha_2 \omega_1}{\sqrt{(\omega_1^2 - \omega_2^2 - \alpha_2^2)^2 + (2\omega_1\alpha_2)^2}}$$

α_2^2 is small compared with ω_2^2 , thus

$$\begin{aligned} \frac{I}{I_r} &= \frac{2\alpha_2 \omega_1}{\sqrt{\left(\omega_1^2 \left(1 - \frac{\omega_2^2}{\omega_1^2}\right)\right)^2 + 4\omega_1^2 \alpha_2^2}} \\ &= \frac{2\alpha_2}{\omega_1 \sqrt{\left(1 - \frac{\omega_2^2}{\omega_1^2}\right)^2 + 4\frac{\alpha_2^2}{\omega_1^2}}} \end{aligned}$$

but

$$\alpha_2 = \frac{R_2}{2L_2}$$

$$\therefore \frac{2\alpha_2}{\omega_1} = \frac{R_2}{2\pi f_1 L_2}$$

and

$$\delta_2 = \frac{R_2}{2L_2 f_2}$$

$$\therefore \frac{R_2}{2L_2} = \delta_2 f_2$$

and

$$\frac{2\alpha_2}{\omega_1} = \frac{\delta_2 f_2}{\pi f_1}$$

$$\begin{aligned} \therefore \frac{I^2}{I_r^2} &= \frac{\left(\frac{\delta_2 f_2}{\pi f_1}\right)^2}{\left(1 - \left(\frac{f_2}{f_1}\right)^2\right)^2 + \frac{\delta_2^2 f_2^2}{\pi^2 f_1^2}} \\ \therefore (1 - x^2)^2 I^2 + \frac{\delta_2^2}{\pi^2} x^2 I^2 &= \frac{\delta_2^2}{\pi^2} I_r^2 \end{aligned}$$

where

$$x = \frac{f_2}{f_1} = \frac{\lambda_1}{\lambda_2}$$

or

$$\delta_2 = \frac{(1 - x^2)^2 I^2 \pi^2}{(I_r^2 - I^2) x^2}$$

and

$$\delta_2 = \frac{\pi}{x} (1 - x^2) \sqrt{\frac{I^2}{I_r^2 - I^2}}$$

If x is near unity then $1 - x^2 = (1 + x)(1 - x) = 2(1 - x)$ and

$$\delta_2 = 2\pi(1 - x) \sqrt{\frac{I^2}{I_r^2 - I^2}}$$

If the secondary current J is read by a hot wire instrument then since the effective values are proportional to the maximum values,

$$\delta_2 = 2\pi \left(1 - \frac{f_2}{f_1}\right) \sqrt{\frac{J^2}{J_r^2 - J^2}}$$

or,

$$\delta_2 = 2\pi \left(1 - \frac{\lambda_1}{\lambda_2}\right) \sqrt{\frac{J^2}{J_r^2 - J^2}}$$

If the frequency of the secondary is so adjusted that $J^2 = \frac{J_r^2}{2}$ then we get

$$\delta_2 = 2\pi \left(1 - \frac{\lambda_1}{\lambda_2}\right) \quad (6)$$

a formula which is used extensively in connection with wave meter measurements.

Inductively Coupled Oscillating Circuits Having Considerable Damping.—We have shown (equation 5) the following relation between the effective secondary current J_r at resonance and the induced e.m.f. E_0 when the primary is supplied from a source of sustained power

$$J_r^2 = \frac{E_0^2}{8f^2 L_2^2 \delta_2^2}$$

The corresponding equation when both the primary and secondary circuits are oscillating has been worked out by BJERKNES and others who found that as long as the decrements are small the following relation obtains:

$$J_{max.}^2 = \frac{NE_0^2}{16f^3L_2^2} \frac{1}{d_1d_2(d_1 + d_2)} \quad (7)$$

In this equation $J_{max.}$ is the maximum possible value of current read by a hot wire instrument in the antenna circuit.

N is the number of condenser discharges per second.

E_0 is the maximum value of the e.m.f. induced in the antenna circuit. L_2 is the inductance of the antenna circuit in henrys, f is the frequency and d_1 and d_2 the logarithmic decrements in the primary and antenna circuits per full period.

$$\begin{aligned} E_0 &= 2\pi fMI_1 = \omega mI_1 \\ I_1 &= 2\pi fC_1E_1 = \omega C_1E_1 \\ \therefore E_0 &= \omega^2MC_1E_1 \text{ and } E_0^2 = \omega^4M^2C_1^2E_1^2 = \omega^4k^2L_2C_1^2E_1^2 \\ \therefore \frac{E_0^2}{L_2^2} &= \omega^4k^2 \frac{L_1}{L_2} C_1^2E_1^2 = \omega^4k^2C_1C_2E_1^2 \\ \therefore J_{max.}^2 &= \frac{N}{16f^3} \frac{16\pi^4f^2C_1C_2E_1^2k^2}{d_1d_2(d_1 + d_2)} = \frac{4\pi^4fC_1C_2E_1^2k^2}{d_1d_2(d_1 + d_2)} \quad (8) \end{aligned}$$

Similarly,

$$J_{max.}^2 = \frac{2\pi^4f^2k^2C_1C_2E_1^2}{d_2^2} \quad (9)$$

In the case of sustained primary power.

The maximum instantaneous value of the antenna current is from (45) remembering that in these equations the decrements per full period is used.

$$I_2^2 = \frac{J_{max.}^2}{N} \frac{4f\delta_2}{N} = 4 \frac{J_{max.}^2}{N^2} f\delta_2 \quad (10)$$

The maximum instantaneous value of the antenna voltage is

$$E_2 = \frac{I_2}{\omega C_2} \quad (11)$$

Numerical Examples.—Union College small set.

$$E_1 = 5000 \text{ volts}$$

$$C_1 = \frac{120}{10^{10}} \text{ farads}$$

$$C_2 = \frac{12}{10^{10}} \text{ farads}$$

$$N = 500$$

$$\lambda = 700 \text{ m.}; \quad \therefore f = 0.43 \cdot 10^6$$

$$\delta_1 = 0.05 \quad \delta_2 = 0.10 \quad k = 0.10 \quad \therefore d_1 d_2 (d_1 + d_2) = \frac{75}{10^5}$$

$$J_{max.}^2 = 50,000 \cdot 0.43 \cdot 10^6 \cdot \frac{12 \times 120}{10^{20}} \cdot 25 \cdot 10^6 \cdot 0.01 \cdot \frac{10^5}{75} = 20$$

$$\therefore J_{max.} = 4.5$$

and

$$I_2^2 = \frac{4 \times 20}{2500} \cdot 0.43 \cdot 10^6 \times 0.10 = 1375$$

or

$$I_2 = 37 \text{ amp.}$$

$$E_2 = \frac{I_2 \text{ } \%}{2\pi \cdot 0.43 \cdot 10^6} \cdot \frac{10^{10}}{12} \cdot 278 \times 37 = 11,400 \text{ volts.}$$

BJERKNES has shown how with a slight modification equation (6) can be used to determine the decrement of the secondary circuit which may, for instance, be the antenna circuit by means of a third tuned circuit which is called a wave meter:

This expression is:

$$\delta + \delta_1 = 2\pi \left(1 - \frac{\lambda_1}{\lambda_0} \right) \quad (12)$$

where δ is the decrement of the circuit being tested and δ_1 is the decrement of the meter.

The formula is limited as is the case of equation (6) to the condition that

$$J^2 = \frac{J_r^2}{2}$$

J_r and J being the effective values of the current in the wave meter.

It is also limited to the condition that both δ and δ_1 are small and that δ_1 is considerably smaller than δ and that finally λ_1 and λ_2 do not differ more than, say, 5 per cent.

Referring to Fig. 156, W is the wave meter which is a calibrated closed circuit of known inductance, capacity and therefore of known natural period. The resistance is made as low as possible so that the decrement of the meter is small.

The value of the current or the (current)² is frequently determined by means of a low resistance heating element, actually a thermal couple, which supplies a direct current to a galvanometer G .

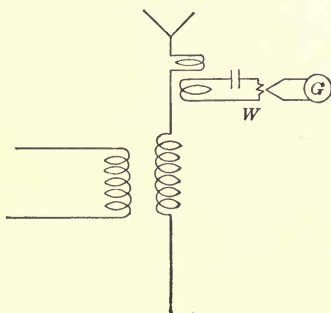

FIG. 156.

In that case the galvanometer deflection is obviously proportional to the square of the current value.

The procedure is as follows. The meter is loosely coupled to the antenna and the capacity of the wave meter is varied until the largest galvanometer deflection G_r is obtained and the corresponding wave length λ_0 is read.

Then the capacity is changed so that the deflection of the galvanometer is $\frac{G_r}{2}$ when the meter reads shorter wave length.

We have then from (12)

$$\delta + \delta_1 = 2\pi \left(1 - \frac{\lambda_1}{\lambda_0}\right).$$

To determine the decrement of the meter it is desirable to insert in the meter circuit such non-inductive resistance that at resonance, that is when the wave meter reads λ_0 , the galvanometer deflection is $\frac{G_r}{2}$.

The capacity is then varied until the galvanometer deflection is $\frac{G_r}{4}$ when the wave length is λ_2 .

We have then if δ_2 is the decrement due to the added resistance,

$$\begin{aligned} \delta + \delta_1 + \delta_2 &= 2\pi \left(1 - \frac{\lambda_2}{\lambda_0}\right) \\ \therefore \delta_2 &= 2\pi \left(1 - \frac{\lambda_2}{\lambda_0}\right) - 2\pi \left(1 - \frac{\lambda_1}{\lambda_0}\right) = 2\pi \frac{\lambda_1 - \lambda_2}{\lambda_0}. \end{aligned}$$

It has been shown in equation (8) that the relation between the effective values of the resonance current with different decrements are related as follows:

$$\frac{J_r^2}{J_r'^2} = \frac{d'_1 d'_2 (d'_1 + d'_2)}{d_1 d_2 (d_1 + d_2)}.$$

In our case

$$\frac{J_r^2}{J_r'^2} = \frac{G_r}{\frac{G_r}{2}} = 2.$$

$d'_1 = \delta =$ decrement of the antenna.

$d'_2 = \delta_1 + \delta_2 =$ decrement of the wave meter in second test.

$d_1 = \delta =$ decrement of the antenna.

$d_2 = \delta_1 =$ decrement of the meter in the first test.

$$\begin{aligned} \therefore 2 &= \frac{(\delta_1 + \delta_2)(\delta + \delta_1 + \delta_2)}{\delta_1(\delta + \delta_2)} \\ &= \frac{\delta_1 + \delta_2}{\delta_1} \frac{1 - \frac{\lambda_2}{\lambda_0}}{1 - \frac{\lambda_1}{\lambda_0}} = \frac{\delta_1 + \delta_2}{\delta_1} \frac{\lambda_0 - \lambda_2}{\lambda_0 - \lambda_1} \\ \therefore \delta_1 &= \frac{2\pi}{\lambda_0} \frac{(\lambda_1 - \lambda_2)(\lambda_0 - \lambda_2)}{\lambda_0 + \lambda_2 - 2\lambda_1}. \end{aligned}$$

Numerical Example.—

$$\lambda_0 = 500 \text{ m.}$$

$$\lambda_1 = 485 \text{ m.}$$

$$\lambda_2 = 475 \text{ m.}$$

$$\therefore \delta + \delta_1 = 2\pi \left(1 - \frac{485}{500}\right) = 0.189.$$

$$\delta + \delta_1 + \delta_2 = 2\pi \left(1 - \frac{475}{500}\right) = 0.314$$

$$\therefore \delta_2 = 0.125.$$

$$\delta_1 = \frac{2\pi}{500} \frac{10 \times 25}{5} = 0.0628.$$

$$\delta = 0.126.$$

Conditions Affecting the Receiving Station.—It has been shown that at some distance from the sending antenna the maximum value of the potential gradient in volts per centimeter near the equatorial plane is

$$G = \frac{120\pi}{r} \frac{h}{\lambda} I \quad (1)$$

where I is the maximum value of the current at the sending antenna, the current being assumed the same at all points of the conductor. The dimensions are given in centimeters.

A more general formula would be

$$E_2 = \frac{120\pi h_1 h_2 \alpha I}{r \lambda} \quad (2)$$

where E_2 is the maximum value of the voltage across the whole receiving antenna. α is a correction factor for the current distribution which is $\frac{2}{\pi}$ for a simple antenna and unity for an antenna in which the height constitutes only a fraction of a quarter wave, as is most frequently the case in actual practice.

h_1 , h_2 , λ and r may be given in any units as long as they are the same. h_1 and h_2 are the heights of the sending and receiv-

ing antenna, λ the wave length and r the distance between h_1 and h_2 .

In order to be applicable to wireless transmission this formula needs to be elaborated in several respects.

(a) The voltage is actually greater due to the concentration of energy as the waves sweep over the surface of the earth.

(b) The voltage is smaller on account of the energy which strays away from the curvature even if the surface of the earth is assumed to be perfect of conductivity.

(c) The voltage is reduced on account of the energy absorption of the earth current which effect is prominent near the sending conductor where the concentration of current is greatest.

(d) The voltage is sometimes increased, but more often reduced, due to reflection, absorption, etc., depending upon the condition of the atmosphere.

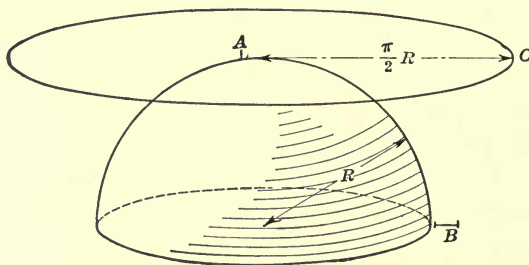

FIG. 157.

Conditions (c) and (d) have not been studied theoretically, but a considerable amount of data has been given from actual tests, notably by AUSTIN and FULLER.¹

The Effect of the Curvature of the Earth.—Assume that the sending antenna is at A and the receiving antenna at B , Fig. 157.

The distance between A and B is $\frac{\pi R}{2}$. In the case of a plane wave the receiving antenna for the same distance would then be at C where,

$$A - C = \frac{\pi}{2}R.$$

Thus in this latter case the energy would be spread over a

¹AUSTIN, Bulletin, Bureau Standards, 1914.

FULLER, Proc., A. I. E. E., April, 1915.

circumference $2\pi\frac{\pi}{2}R$ whereas due to the curvature of the earth the circumference is only $2\pi R$. There is, therefore, a concentration of energy which can be represented by a coefficient

$$k' = \frac{\pi^2 r}{2\pi R} = \frac{\pi}{2}$$

and since the intensity of the electric field is proportional to the $\sqrt{\text{energy}}$, the concentration coefficient for the electric field at a distance r under the condition given above is

$$k = \sqrt{\frac{\pi}{2}}$$

Let distance AC , Fig. 157, be equal to $AB = R\theta$. \therefore Energy per unit length of circumference at C is

$$\frac{E}{2\pi R\theta}$$

Energy per unit circumference at B is

$$\frac{E}{2\pi R \sin \theta}$$

$$\therefore K' = \frac{2\pi R\theta}{2\pi R \sin \theta} = \frac{\theta}{\sin \theta} \text{ or } k = \sqrt{\frac{\theta}{\sin \theta}} \quad (3)$$

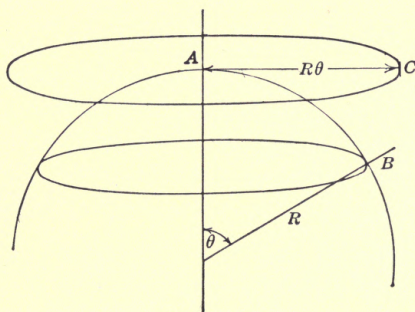

FIG. 158.

The effect of the straying of power on the potential gradient due to the curvature of the earth is included in the equation according to theoretical works done by SUMMERFIELD and ZENNECK by the introduction of a divergence factor.

$$k_1 = \epsilon \frac{0.0019r}{\sqrt[3]{\lambda}}$$

AUSTIN's experiments indicate, however, that with continuous waves this coefficient is:

$$\left. \begin{aligned} k_1 &= \epsilon \frac{0.0915r}{\sqrt{\lambda}} \\ \text{and FULLER's experiments show} \\ k_1 &= \epsilon \frac{0.0045r}{\lambda^{1.414}} \end{aligned} \right\} \quad (4)$$

AUSTIN's equation gives values which lie between ZENNECK's and FULLER's and has the advantage of being simpler than the other two.

Thus the general formula for continuous waves becomes:

$$E_2 = k k_1 \frac{120\pi h_1 h_2 \alpha I}{r\lambda} \quad (5)$$

Note, however, that in equation (4) the dimensions are expressed in kilometers.

The maximum value of the antenna current in the case of sustained oscillations is evidently $I_2 = \frac{E_2}{R_2}$ where R_2 is the total resistance of the antenna that is the radiation resistance, the effective resistance, ground resistance, and resistance of the receiving device.

$$\therefore I_2 = k k_1 \frac{120\pi h_1 h_2 \alpha I}{r\lambda R_2} \quad (6)$$

The equation of the current in the case of damped oscillations is slightly different.

It has been shown that if an e.m.f., E_0 , is impressed on a tuned circuit the following relations obtain:

$$J_2^2 = \frac{N E_0^2}{16 f^3 L_2^2 d_1 d_2^2 (d_1 + d_2)} \quad (7)$$

where E_0 is the voltage induced, which in our case is E_2 . d_1 and d_2 are the decrements in the two circuits.

Thus d_1 and d_2 are in this case the decrements of the sending and receiving circuits respectively.

Equation (7) may be written:

$$J_2^2 = \frac{N E_2^2}{16 f^3 L_2^2 d_1 d_2^2 \left(1 + \frac{d_1}{d_2}\right)}$$

But the decrement of the receiving antenna is

$$\begin{aligned} d_2 &= \frac{R_2}{2 \cdot L_2 f} \\ \therefore J_2^2 &= \frac{N E_2^2}{4 f R_2^2 d_1 \left(1 + \frac{d_1}{d_2}\right)} = \frac{N g_2 I_1^2}{4 f R_2^2 d_1 \left(1 + \frac{d_1}{d_2}\right)} \end{aligned} \quad (8)$$

where

$$g^2 = \left(k \frac{k_1 120}{r} \pi \frac{h}{\lambda} h_2 \alpha \right)^2$$

but $I_1^2 = J_1^2 \frac{4fd_1}{N}$ where J_1 is the effective value of the sending antenna current.

$$\therefore d_1 = \frac{I_1^2}{J_1^2} \frac{N}{4f}$$

$$\therefore J_2^2 = \frac{Ng^2 J_1^2 4f}{4fR_2^2 \left(1 + \frac{d_1}{d_2}\right) N} = \frac{g_2 J_1^2}{R_2^2 \left(1 + \frac{d_1}{d_2}\right)}$$

and

$$J^2 = \frac{gJ_1}{R_2 \sqrt{1 + \frac{d_1}{d_2}}} \quad (9)$$

The effective value of the voltage across the receiving antenna is $J_2 R_2$.

$$\therefore \epsilon_2 = \frac{gJ_1}{\sqrt{1 + \frac{d_1}{d_2}}} = \frac{kk_1 120}{r \sqrt{1 + \frac{d_1}{d_2}}} \pi \frac{h}{\lambda} h_2 \alpha J_1 \quad (10)$$

where ϵ_2 is the effective value of the receiving voltage and J_1 is the effective current at the base of the sending antenna.

It is evident from the above that the ratio between the effective values of the received e.m.f. with sustained and with damped oscillations is:

$$\frac{\text{sustained}}{\text{damped}} = \sqrt{1 + \frac{d_1}{d_2}};$$

if the decrements of the sending and receiving antennas were the same then the ratio would be $\sqrt{2}$.

Method of Determining Power Received.—AUSTIN based his determinations on the fact that if in two circuits in parallel we know the power in one we can calculate the power in the other and the total power from the relations of the resistances $R\gamma S'$ in the circuits.

The total power supplied is

$$EI = E \left(\frac{E}{R} + \frac{E}{S} \right) = E^2 \frac{R + S}{RS}$$

The power of circuit R is

$$P_r = \frac{E^2}{R}$$

$$\therefore \frac{EI}{P_r} = \frac{R + S}{RS} \quad R = \frac{R + S}{S}$$

or the total power = $\frac{R + S}{S} P_r$.

The minimum power P_r required for distinguishing between dots and dashes of resistance R is determined experimentally by observing the current in the receiving antenna under conditions that can be conveniently controlled.

Knowing P_r and R and the resistance S which is shunted across the telephone receiver enables one to determine the total power received. In FULLER's experiments at Honolulu this minimum power was found to be 3.2×10^{10} watt, when dealing with sustained oscillations.

APPENDIX I

Partial Differentiation.—The complete differential of a function V of several independent variables r, φ, θ is recalled to be:

$$dV = \frac{\partial V}{\partial r} dr + \frac{\partial V}{\partial \varphi} d\varphi + \frac{\partial V}{\partial \theta} d\theta \quad (1)$$

In words this equation reads: The total differential of V is the sum of the partial differentials of V with respect to the independent variables. $\frac{\partial V}{\partial r}$ meaning the derivative of V with respect to r when φ and θ are considered constant.

If the independent variables $r, \varphi,$ and θ are some functions of a single other variables t the derivative of V with respect to t is obtained by simply dividing equation (1) by dt .

$$\text{Thus:} \quad \frac{dV}{dt} = \frac{\partial V}{\partial r} \frac{dr}{dt} + \frac{\partial V}{\partial \varphi} \frac{d\varphi}{dt} + \frac{\partial V}{\partial \theta} \frac{d\theta}{dt} \quad (2)$$

If the independent variables r, φ and θ are functions of several other independent variables, for instance $x, y, z,$ then the partial derivative of V with respect to x is obtained in a similar way by dividing the equation by $dx,$ remembering, however, that now $\frac{dV}{dx}$ is the partial derivative and should be written $\frac{\partial V}{\partial x}.$

$$\text{Thus} \quad \frac{\partial V}{\partial x} = \frac{\partial V}{\partial r} \frac{\partial r}{\partial x} + \frac{\partial V}{\partial \varphi} \frac{\partial \varphi}{\partial x} + \frac{\partial V}{\partial \theta} \frac{\partial \theta}{\partial x} \quad (3)$$

$$\text{Similarly} \quad \frac{\partial V}{\partial y} = \frac{\partial V}{\partial r} \frac{\partial r}{\partial y} + \frac{\partial V}{\partial \varphi} \frac{\partial \varphi}{\partial y} + \frac{\partial V}{\partial \theta} \frac{\partial \theta}{\partial y} \quad (4)$$

$$\text{and} \quad \frac{\partial V}{\partial z} = \frac{\partial V}{\partial r} \frac{\partial r}{\partial z} + \frac{\partial V}{\partial \varphi} \frac{\partial \varphi}{\partial z} + \frac{\partial V}{\partial \theta} \frac{\partial \theta}{\partial z} \quad (5)$$

The second partial derivative of V with respect to x is obviously obtained from (3) as follows:

$$\begin{aligned} \frac{\partial^2 V}{\partial x^2} = \frac{\partial V}{\partial r} \frac{\partial^2 r}{\partial x^2} + \frac{\partial r}{\partial x} \frac{\partial}{\partial x} \left(\frac{\partial V}{\partial r} \right) + \frac{\partial V}{\partial \varphi} \frac{\partial^2 \varphi}{\partial x^2} + \frac{\partial \varphi}{\partial x} \frac{\partial}{\partial x} \left(\frac{\partial V}{\partial \varphi} \right) \\ + \frac{\partial V}{\partial \theta} \frac{\partial^2 \theta}{\partial x^2} + \frac{\partial \theta}{\partial x} \frac{\partial}{\partial x} \left(\frac{\partial V}{\partial \theta} \right) \end{aligned} \quad (6)$$

In equation (6) $\frac{\partial V}{\partial r}$, $\frac{\partial V}{\partial \varphi}$ and $\frac{\partial V}{\partial \theta}$ are each functions of r , φ and θ .

$$\begin{aligned} \therefore \frac{\partial}{\partial x} \left(\frac{\partial V}{\partial r} \right) &= \frac{\partial^2 V}{\partial r^2} \frac{\partial r}{\partial x} + \frac{\partial^2 V}{\partial r \partial \varphi} \frac{\partial \varphi}{\partial x} + \frac{\partial^2 V}{\partial r \partial \theta} \frac{\partial \theta}{\partial x} \\ \frac{\partial}{\partial x} \left(\frac{\partial V}{\partial \varphi} \right) &= \frac{\partial^2 V}{\partial \varphi \partial r} \frac{\partial r}{\partial x} + \frac{\partial^2 V}{\partial \varphi^2} \frac{\partial \varphi}{\partial x} + \frac{\partial^2 V}{\partial \varphi \partial \theta} \frac{\partial \theta}{\partial x} \end{aligned} \quad (7)$$

and,

$$\frac{\partial}{\partial x} \left(\frac{\partial V}{\partial \theta} \right) = \frac{\partial^2 V}{\partial \theta \partial r} \frac{\partial r}{\partial x} + \frac{\partial^2 V}{\partial \varphi \partial \theta} \frac{\partial \varphi}{\partial x} + \frac{\partial^2 V}{\partial \theta^2} \frac{\partial \theta}{\partial x}$$

Substituting these values in equation (6) we get:

$$\begin{aligned} \frac{\partial^2 V}{\partial x^2} &= \frac{\partial V}{\partial r} \frac{\partial^2 r}{\partial x^2} + \frac{\partial V}{\partial \varphi} \frac{\partial^2 \varphi}{\partial x^2} + \frac{\partial V}{\partial \theta} \frac{\partial^2 \theta}{\partial x^2} \\ &+ \frac{\partial^2 V}{\partial r^2} \left(\frac{\partial r}{\partial x} \right)^2 + \frac{\partial^2 V}{\partial \varphi^2} \left(\frac{\partial \varphi}{\partial x} \right)^2 + \frac{\partial^2 V}{\partial \theta^2} \left(\frac{\partial \theta}{\partial x} \right)^2 \\ &+ \frac{2\partial^2 V}{\partial r \partial \varphi} \frac{\partial r}{\partial x} \frac{\partial \varphi}{\partial x} + \frac{2\partial^2 V}{\partial r \partial \theta} \frac{\partial r}{\partial x} \frac{\partial \theta}{\partial x} + \frac{2\partial^2 V}{\partial \varphi \partial \theta} \frac{\partial \varphi}{\partial x} \frac{\partial \theta}{\partial x} \end{aligned} \quad (8)$$

A similar expression is, of course, obtained for

$$\frac{\partial^2 V}{\partial y^2} \text{ and } \frac{\partial^2 V}{\partial z^2}$$

A complete discussion of partial differentiation can be found in any text-book on Calculus, for instance, in volume II of WOODS AND BAILEY'S "A Course in Mathematics."

As an application of the above is given the transformation of LAPLACE'S equation from rectangular coördinates to spherical and cylindrical coördinates.

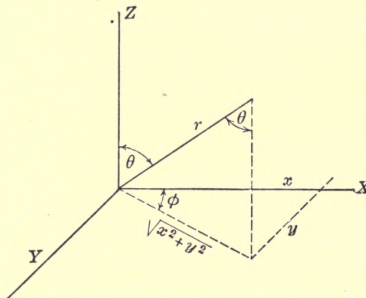

FIG. 159.

(a) Transformation of LAPLACE'S equation to spherical coördinates. Fig. 159.

$$\frac{\partial^2 V}{\partial x^2} + \frac{\partial^2 V}{\partial y^2} + \frac{\partial^2 V}{\partial z^2} = 0$$

$$\begin{aligned}
 V &= F(r\theta\varphi), \quad r = f_1(xyz), \quad \theta = f_2(xyz), \quad \varphi = f_3(xyz), \\
 \frac{\partial V}{\partial x} &= \frac{\partial V}{\partial r} \frac{\partial r}{\partial x} + \frac{\partial V}{\partial \theta} \frac{\partial \theta}{\partial x} + \frac{\partial V}{\partial \varphi} \frac{\partial \varphi}{\partial x} \\
 \frac{\partial^2 V}{\partial x^2} &= \frac{\partial V}{\partial r} \frac{\partial^2 r}{\partial x^2} + \frac{\partial r}{\partial x} \frac{\partial}{\partial x} \left(\frac{\partial V}{\partial r} \right) + \frac{\partial V}{\partial \theta} \frac{\partial^2 \theta}{\partial x^2} + \frac{\partial \theta}{\partial x} \frac{\partial}{\partial x} \left(\frac{\partial V}{\partial \theta} \right) \\
 &\quad + \frac{\partial V}{\partial \varphi} \frac{\partial^2 \varphi}{\partial x^2} + \frac{\partial \varphi}{\partial x} \frac{\partial}{\partial x} \left(\frac{\partial V}{\partial \varphi} \right).
 \end{aligned}$$

But

$$\begin{aligned}
 \frac{\partial}{\partial x} \left(\frac{\partial V}{\partial r} \right) &= \frac{\partial^2 V}{\partial r^2} \frac{\partial r}{\partial x} + \frac{\partial^2 V}{\partial r \partial \theta} \frac{\partial \theta}{\partial x} + \frac{\partial^2 V}{\partial r \partial \varphi} \frac{\partial \varphi}{\partial x} \\
 \frac{\partial}{\partial x} \left(\frac{\partial V}{\partial \theta} \right) &= \frac{\partial^2 V}{\partial \theta \partial r} \frac{\partial r}{\partial x} + \frac{\partial^2 V}{\partial \theta^2} \frac{\partial \theta}{\partial x} + \frac{\partial^2 V}{\partial \theta \partial \varphi} \frac{\partial \varphi}{\partial x} \\
 \frac{\partial}{\partial x} \left(\frac{\partial V}{\partial \varphi} \right) &= \frac{\partial^2 V}{\partial \varphi \partial r} \frac{\partial r}{\partial x} + \frac{\partial^2 V}{\partial \varphi \partial \theta} \frac{\partial \theta}{\partial x} + \frac{\partial^2 V}{\partial \varphi^2} \frac{\partial \varphi}{\partial x} \\
 \therefore \frac{\partial^2 V}{\partial x^2} &= \frac{\partial V}{\partial r} \frac{\partial^2 r}{\partial x^2} + \frac{\partial V}{\partial \theta} \frac{\partial^2 \theta}{\partial x^2} + \frac{\partial V}{\partial \varphi} \frac{\partial^2 \varphi}{\partial x^2} \\
 &\quad + \frac{\partial^2 V}{\partial r^2} \left(\frac{\partial r}{\partial x} \right)^2 + \frac{\partial^2 V}{\partial \theta^2} \left(\frac{\partial \theta}{\partial x} \right)^2 + \frac{\partial^2 V}{\partial \varphi^2} \left(\frac{\partial \varphi}{\partial x} \right)^2 \\
 &\quad + \frac{2\partial^2 V}{\partial r \partial \theta} \frac{\partial r}{\partial x} \frac{\partial \theta}{\partial x} + \frac{2\partial^2 V}{\partial r \partial \varphi} \frac{\partial r}{\partial x} \frac{\partial \varphi}{\partial x} + \frac{2\partial^2 V}{\partial \theta \partial \varphi} \frac{\partial \theta}{\partial x} \frac{\partial \varphi}{\partial x}
 \end{aligned}$$

Similar expressions can be gotten for $\frac{\partial^2 V}{\partial y^2}$ and $\frac{\partial^2 V}{\partial z^2}$.

$$\begin{aligned}
 \therefore \frac{\partial^2 V}{\partial x^2} + \frac{\partial^2 V}{\partial y^2} + \frac{\partial^2 V}{\partial z^2} &= \frac{\partial V}{\partial r} \left(\frac{\partial^2 r}{\partial x^2} + \frac{\partial^2 r}{\partial y^2} + \frac{\partial^2 r}{\partial z^2} \right) \\
 &\quad + \frac{\partial V}{\partial \theta} \left(\frac{\partial^2 \theta}{\partial x^2} + \frac{\partial^2 \theta}{\partial y^2} + \frac{\partial^2 \theta}{\partial z^2} \right) + \frac{\partial V}{\partial \varphi} \left(\frac{\partial^2 \varphi}{\partial x^2} + \frac{\partial^2 \varphi}{\partial y^2} + \frac{\partial^2 \varphi}{\partial z^2} \right) \\
 &\quad + \frac{\partial^2 V}{\partial r^2} \left[\left(\frac{\partial r}{\partial x} \right)^2 + \left(\frac{\partial r}{\partial y} \right)^2 + \left(\frac{\partial r}{\partial z} \right)^2 \right] + \frac{\partial^2 V}{\partial \theta^2} \left[\left(\frac{\partial \theta}{\partial x} \right)^2 + \left(\frac{\partial \theta}{\partial y} \right)^2 + \left(\frac{\partial \theta}{\partial z} \right)^2 \right] \\
 &\quad + \frac{\partial^2 V}{\partial \varphi^2} \left[\left(\frac{\partial \varphi}{\partial x} \right)^2 + \left(\frac{\partial \varphi}{\partial y} \right)^2 + \left(\frac{\partial \varphi}{\partial z} \right)^2 \right] + \frac{2\partial^2 V}{\partial r \partial \theta} \left[\frac{\partial r}{\partial x} \frac{\partial \theta}{\partial x} + \frac{\partial r}{\partial y} \frac{\partial \theta}{\partial y} \right. \\
 &\quad \left. + \frac{\partial r}{\partial z} \frac{\partial \theta}{\partial z} \right] + \frac{2\partial^2 V}{\partial r \partial \varphi} \left[\frac{\partial r}{\partial x} \frac{\partial \varphi}{\partial x} + \frac{\partial r}{\partial y} \frac{\partial \varphi}{\partial y} + \frac{\partial r}{\partial z} \frac{\partial \varphi}{\partial z} \right] \\
 &\quad + \frac{2\partial^2 V}{\partial \theta \partial \varphi} \left[\frac{\partial \theta}{\partial x} \frac{\partial \varphi}{\partial x} + \frac{\partial \theta}{\partial y} \frac{\partial \varphi}{\partial y} + \frac{\partial \theta}{\partial z} \frac{\partial \varphi}{\partial z} \right]
 \end{aligned}$$

but in the spherical coordinate system,

$$r = (x^2 + y^2 + z^2)^{1/2}, \quad \theta = \arctan \frac{\sqrt{x^2 + y^2}}{z} \quad \text{and} \quad \varphi = \arctan \frac{y}{x}$$

From the construction, Fig. 159,

$$x = \sqrt{x^2 + y^2} \cos \varphi = r \sin \theta \cos \varphi; \quad y = r \sin \theta \sin \varphi; \quad z = r \cos \theta.$$

$$\therefore \frac{\partial r}{\partial x} = \frac{x}{(x^2 + y^2 + z^2)^{1/2}} = \frac{x}{r} = \sin \theta \cos \varphi$$

$$\frac{\partial r}{\partial y} = \frac{y}{(x^2 + y^2 + z^2)^{1/2}} = \frac{y}{r} = \sin \theta \sin \varphi$$

$$\frac{\partial r}{\partial z} = \frac{z}{(x^2 + y^2 + z^2)^{1/2}} = \frac{z}{r} = \cos \theta$$

$$\begin{aligned} \frac{\partial \theta}{\partial x} &= \frac{\frac{1}{2} \frac{\partial}{\partial x} (x^2 + y^2)^{1/2}}{1 + \frac{x^2 + y^2}{z^2}} = \frac{z}{x^2 + y^2 + z^2} \times \frac{x}{(x^2 + y^2)^{1/2}} \\ &= \frac{z}{r^2} \cos \varphi = \frac{z}{r} \frac{\cos \varphi}{r} = \frac{\cos \theta \cos \varphi}{r} \end{aligned}$$

$$\begin{aligned} \frac{\partial \theta}{\partial y} &= \frac{z}{x^2 + y^2 + z^2} \times \frac{y}{(x^2 + y^2)^{1/2}} \\ &= \frac{\cos \theta \sin \varphi}{r} \end{aligned}$$

$$\begin{aligned} \frac{\partial \theta}{\partial z} &= \frac{(x^2 + y^2)^{1/2} \frac{\partial}{\partial z} \left(\frac{1}{z} \right)}{1 + \frac{x^2 + y^2}{z^2}} = - \frac{(x^2 + y^2)^{1/2}}{x^2 + y^2 + z^2} \\ &= - \frac{(x^2 + y^2)^{1/2}}{r^2} = - \frac{\sin \theta}{r} \end{aligned}$$

$$\begin{aligned} \frac{\partial \varphi}{\partial x} &= \frac{y \frac{\partial}{\partial x} \left(\frac{1}{x} \right)}{1 + \frac{y^2}{x^2}} = - \frac{y}{x^2 + y^2} = - \frac{y}{\sqrt{x^2 + y^2}} \times \frac{r}{r\sqrt{x^2 + y^2}} \\ &= - \frac{\sin \varphi}{r \sin \theta} \end{aligned}$$

$$\frac{\partial \varphi}{\partial y} = \frac{\frac{1}{x}}{1 + \frac{y^2}{x^2}} = \frac{x}{x^2 + y^2} = \frac{x}{\sqrt{x^2 + y^2}} \times \frac{r}{r\sqrt{x^2 + y^2}} = \frac{\cos \varphi}{r \sin \theta}$$

$$\frac{\partial \varphi}{\partial z} = 0$$

$$\begin{aligned} \frac{\partial^2 r}{\partial x^2} &= \frac{\partial}{\partial x} (\sin \theta \cos \varphi) = \cos \theta \cos \varphi \frac{\partial \theta}{\partial x} - \sin \theta \sin \varphi \frac{\partial \varphi}{\partial x} = \\ &= \cos \theta \cos \varphi \times \frac{\cos \theta \cos \varphi}{r} + \sin \theta \sin \varphi \frac{\sin \varphi}{r \sin \theta} \\ &= \frac{1}{r} [\cos^2 \theta \cos^2 \varphi + \sin^2 \varphi] \end{aligned}$$

$$= \frac{1}{r} [(1 - \sin^2 \theta)(1 - \sin^2 \varphi) + \sin^2 \varphi]$$

$$= \frac{1}{r} [1 - \sin^2 \theta \cos^2 \varphi]$$

$$\frac{\partial^2 r}{\partial y^2} = \frac{\partial}{\partial y} (\sin \theta \sin \varphi) = \frac{1}{r} [1 - \sin^2 \theta \sin^2 \varphi]$$

$$\frac{\partial^2 r}{\partial z^2} = \frac{\partial}{\partial z} \cos \theta = -\sin \theta \frac{\partial \theta}{\partial z} = +\frac{1}{r} \sin^2 \theta$$

$$\frac{\partial^2 \theta}{\partial x^2} = \frac{\partial}{\partial x} \frac{\cos \theta \cos \varphi}{r} = \cos \theta \cos \varphi \left(-\frac{1}{r^2} \right) \frac{\partial r}{\partial x} \cos \varphi$$

$$(-\sin \theta) \frac{\partial \theta}{\partial x} + \frac{1}{r} \cos \theta (-\sin \varphi) \frac{\partial \varphi}{\partial x}$$

$$= -\frac{1}{r^2} (\cos \theta \cos \varphi \sin \theta \cos \varphi)$$

$$+ \frac{1}{r} \left(-\cos \varphi \sin \theta \frac{\cos \theta \cos \varphi}{r} \right)$$

$$+ \frac{1}{r} \cos \theta \sin \varphi \frac{\sin \varphi}{r \sin \theta}$$

$$= -\left[\frac{1}{r^2} \sin \theta \cos \theta \cos^2 \varphi + \sin \theta \cos \theta \cos^2 \varphi - \frac{\cos \theta}{\sin \theta} \sin^2 \varphi \right]$$

$$\frac{\partial^2 \theta}{\partial y^2} = \frac{\partial}{\partial y} \frac{1}{r} \cos \theta \sin \varphi = \dots = -\frac{1}{r^2} \left[2 \sin \theta \cos \theta \sin^2 \varphi \right.$$

$$\left. - \frac{\cos \theta}{\sin \theta} \cos^2 \varphi \right]$$

$$\frac{\partial^2 \theta}{\partial z^2} = \frac{\partial}{\partial z} \left(-\frac{\sin \theta}{r} \right) = \dots = \frac{2}{r^2} \sin \theta \cos \theta$$

$$\frac{\partial^2}{\partial x^2} = -\frac{\partial}{\partial x} \left(\frac{\sin \varphi}{r \sin \theta} \right) = \frac{1}{r^2} \frac{\sin \varphi}{\sin \theta} \frac{\partial r}{\partial x} - \frac{1}{r} \frac{(-\sin \varphi \cos \theta)}{\sin^2 \theta} \frac{\partial \theta}{\partial x}$$

$$- \frac{\cos \varphi}{r \sin \theta} \frac{\partial}{\partial x}$$

$$= \frac{1}{r^2} \frac{\sin \varphi}{\sin \theta} \frac{\partial r}{\partial x} + \frac{1}{r} \frac{\sin \varphi \cos \theta}{\sin^2 \theta} \frac{\partial \theta}{\partial x} - \frac{\cos \varphi}{r \sin \theta} \frac{\partial \varphi}{\partial x}$$

$$\frac{\partial^2}{\partial y^2} = \frac{\partial}{\partial y} \left(\frac{\cos \varphi}{r \sin \theta} \right) = -\frac{1}{r^2} \frac{\cos \varphi}{\sin \theta} \frac{\partial \varphi}{\partial y} - \frac{1}{r} \frac{\cos \varphi \cos \theta}{\sin^2 \theta} \frac{\partial \theta}{\partial y}$$

$$- \frac{\sin \varphi}{r \sin \theta} \frac{\partial \varphi}{\partial y}$$

$$\frac{d^2 \varphi}{dz^2} = 0$$

$$\begin{aligned} \therefore \frac{\partial^2 \varphi}{\partial x^2} + \frac{\partial^2 \varphi}{\partial y^2} + \frac{\partial^2 \varphi}{\partial z^2} &= \frac{1}{r^2} \frac{\sin \varphi}{\sin \theta} \sin \theta \cos \varphi + \frac{1}{r} \frac{\sin \varphi \cos \theta}{\sin^2 \theta} \\ &\frac{\cos \theta \cos \varphi}{r} + \frac{\cos \varphi \sin \varphi}{r \sin \theta r \sin \theta} - \frac{1}{r^2} \frac{\cos \varphi}{\sin \theta} \sin \theta \sin \varphi \\ &\quad - \frac{1}{r} \frac{\cos \varphi \cos \theta}{\sin^2 \theta} \frac{\cos \theta \sin \varphi}{r} - \frac{\sin \varphi \cos \varphi}{r \sin \theta r \sin \theta} = 0. \end{aligned}$$

$$\begin{aligned} \therefore \frac{\partial^2 r}{\partial x^2} + \frac{\partial^2 r}{\partial y^2} + \frac{\partial^2 r}{\partial z^2} &= \\ &\frac{1}{r} [1 - \sin^2 \theta \cos^2 \varphi + 1 - \sin^2 \varphi + \sin^2 \theta] = \frac{2}{r} \end{aligned}$$

$$\frac{\partial^2 \theta}{\partial x^2} + \frac{\partial^2 \theta}{\partial y^2} + \frac{\partial^2 \theta}{\partial z^2} = \dots \dots \dots = \frac{1}{r^2} = \frac{\cos \theta}{\sin \theta}$$

$$\begin{aligned} \left(\frac{\partial r}{\partial x}\right)^2 + \left(\frac{\partial r}{\partial y}\right)^2 + \left(\frac{\partial r}{\partial z}\right)^2 &= \\ \sin^2 \theta \cos^2 \varphi + \sin^2 \theta \sin^2 \varphi + \cos^2 \theta &= 1 \end{aligned}$$

$$\left(\frac{\partial \theta}{\partial x}\right)^2 + \left(\frac{\partial \theta}{\partial y}\right)^2 + \left(\frac{\partial \theta}{\partial z}\right)^2 = \dots \dots \dots = \frac{1}{r^2 \sin^2 \theta}$$

$$\left(\frac{\partial \varphi}{\partial x}\right)^2 + \left(\frac{\partial \varphi}{\partial y}\right)^2 + \left(\frac{\partial \varphi}{\partial z}\right)^2 = \frac{1}{r^2 \sin^2 \theta}$$

$$\frac{\partial r}{\partial x} \frac{\partial \theta}{\partial x} + \frac{\partial r}{\partial y} \frac{\partial \theta}{\partial y} + \frac{\partial r}{\partial z} \frac{\partial \theta}{\partial z} = \frac{1}{r} (\sin \theta \cos \theta \cos^2 \varphi + \sin \theta \cos \theta \sin^2 \varphi - \sin \theta \cos \theta) = 0$$

$$\frac{\partial r}{\partial x} \frac{\partial \varphi}{\partial x} + \frac{\partial r}{\partial y} \frac{\partial \varphi}{\partial y} + \frac{\partial r}{\partial z} \frac{\partial \varphi}{\partial z} = 0$$

$$\frac{\partial \theta}{\partial x} \frac{\partial \varphi}{\partial x} + \frac{\partial \theta}{\partial y} \frac{\partial \varphi}{\partial y} + \frac{\partial \theta}{\partial z} \frac{\partial \varphi}{\partial z} = 0$$

$$\begin{aligned} \therefore \frac{\partial^2 V}{\partial x^2} + \frac{\partial^2 V}{\partial y^2} + \frac{\partial^2 V}{\partial z^2} &= \frac{\partial V}{\partial r} \left[\frac{\partial^2 r}{\partial x^2} + \frac{\partial^2 r}{\partial y^2} + \frac{\partial^2 r}{\partial z^2} \right] + \frac{\partial V}{\partial \theta} \left[\frac{\partial^2 \theta}{\partial x^2} + \frac{\partial^2 \theta}{\partial y^2} + \frac{\partial^2 \theta}{\partial z^2} \right] \\ &+ \frac{\partial^2 V}{\partial r^2} \left[\left(\frac{\partial r}{\partial x}\right)^2 + \left(\frac{\partial r}{\partial y}\right)^2 + \left(\frac{\partial r}{\partial z}\right)^2 \right] + \frac{\partial^2 V}{\partial \theta^2} \left[\left(\frac{\partial \theta}{\partial x}\right)^2 + \left(\frac{\partial \theta}{\partial y}\right)^2 + \left(\frac{\partial \theta}{\partial z}\right)^2 \right] \\ &+ \frac{\partial^2 V}{\partial \varphi^2} \left[\left(\frac{\partial \varphi}{\partial x}\right)^2 + \left(\frac{\partial \varphi}{\partial y}\right)^2 + \left(\frac{\partial \varphi}{\partial z}\right)^2 \right] = \frac{2}{r} \frac{\partial V}{\partial r} + \frac{1}{r^2} \frac{\cos \theta}{\sin \theta} \frac{\partial V}{\partial \theta} \\ &\quad + \frac{\partial^2 V}{\partial r^2} + \frac{1}{r^2} \frac{\partial^2 V}{\partial \theta^2} + \frac{1}{r^2 \sin^2 \theta} \frac{\partial^2 V}{\partial \varphi^2} \\ &= \frac{1}{r^2} \left[\underbrace{r \left(2 \frac{\partial V}{\partial r} + r \frac{\partial^2 V}{\partial r^2} \right)}_A + \underbrace{\frac{1}{\sin \theta} \left(\cos \theta \frac{\partial V}{\partial \theta} + \sin \theta \frac{\partial^2 V}{\partial \theta^2} \right)}_B + \frac{1}{\sin^2 \theta} \frac{\partial^2 V}{\partial \varphi^2} \right] \end{aligned}$$

But

$$\frac{\partial}{\partial r}(rV) = r \frac{\partial V}{\partial r} + V \quad \therefore \frac{\partial^2}{\partial r^2}(rV) = r \frac{\partial^2 V}{\partial r^2} + \frac{\partial V}{\partial r} + \frac{\partial V}{\partial r} \quad \therefore \frac{\partial^2}{\partial r^2}(rV) = r \frac{\partial^2 V}{\partial r^2} + 2 \frac{\partial V}{\partial r} \quad \therefore A = \frac{\partial^2}{\partial r^2}(rV)$$

$$\frac{\partial}{\partial \theta} \left(\sin \theta \frac{\partial V}{\partial \theta} \right) = \sin \theta \frac{\partial^2 V}{\partial \theta^2} + \frac{\partial V}{\partial \theta} \cos \theta \quad \therefore B = \frac{\partial}{\partial \theta} \left(\sin \theta \frac{\partial V}{\partial \theta} \right)$$

\therefore LAPLACE'S equation in spherical coördinates

$$\frac{1}{r^2} \left[r \frac{\partial^2}{\partial r^2}(rV) + \frac{1}{\sin \theta} \frac{\partial}{\partial \theta} \left(\sin \theta \frac{\partial V}{\partial \theta} \right) + \frac{1}{\sin^2 \theta} \frac{\partial^2 V}{\partial \varphi^2} \right] = 0$$

(C) CYLINDRICAL COÖRDINATES

Referring in Fig. 160

$$V = F(r\theta z) \quad r = (x^2 + y^2)^{1/2}, \quad \theta = \tan^{-1} \frac{y}{x} \quad z = z$$

$$x = r \cos \theta, \quad y = r \sin \theta \quad z = z$$

$$\frac{\partial r}{\partial x} = \frac{x}{(x^2 + y^2)^{1/2}} = \frac{x}{r} = \cos \theta$$

$$\frac{\partial r}{\partial y} = \sin \theta$$

$$\frac{\partial r}{\partial z} = 0$$

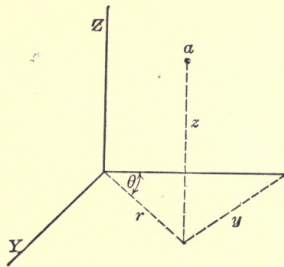

FIG. 160.

$$\frac{\partial \theta}{\partial x} = \frac{y \frac{\partial}{\partial x} \left(\frac{1}{x} \right)}{1 + \left(\frac{y}{x} \right)^2} = - \frac{y}{x^2 + y^2} = - \frac{y}{r^2} = - \frac{\sin \theta}{r}$$

$$\frac{\partial \theta}{\partial y} = \frac{\frac{1}{x}}{1 + \left(\frac{y}{x} \right)^2} = \frac{x}{r^2} = \frac{\cos \theta}{r}$$

$$\frac{\partial \theta}{\partial z} = 0$$

$$\frac{\partial z}{\partial x} = \frac{\partial z}{\partial y} = 0 = \frac{\partial z}{\partial z} = 1$$

$$\frac{\partial^2 r}{\partial x^2} = \frac{\partial}{\partial x} \cos \theta = -\sin \theta \frac{\partial \theta}{\partial x} = + \frac{\sin^2 \theta^2}{r}$$

$$\frac{\partial^2 r}{\partial y^2} = \frac{\partial}{\partial y} \cos \theta = -\sin \theta \frac{\partial \theta}{\partial y} = + \frac{\cos^2 \theta}{r}$$

$$\frac{\partial^2 r}{\partial z^2} = 0$$

$$\frac{\partial^2 \theta}{\partial x^2} = \frac{\partial}{\partial x} \left(-\frac{\sin \theta}{r} \right) = -\frac{1}{r} \sin \theta \frac{\partial \theta}{\partial x} + \frac{1}{r^2} \sin \theta \frac{\partial r}{\partial x} = \frac{2}{r^2} \sin \theta \cos \theta$$

$$\frac{\partial^2 \theta}{\partial y^2} = \frac{\partial}{\partial y} \left(-\frac{\cos \theta}{r} \right) = -\frac{1}{r} \cos \theta \frac{\partial \theta}{\partial y} - \frac{1}{r^2} \cos \theta \frac{\partial r}{\partial y} = -\frac{2}{r^2} \sin \theta \cos \theta$$

$$\frac{\partial^2 \theta}{\partial z^2} = 0$$

$$\frac{\partial^2 z}{\partial x^2} = \frac{\partial^2 z}{\partial y^2} = \frac{\partial^2 z}{\partial z^2} = 0$$

$$\therefore \frac{\partial^2 r}{\partial x^2} + \frac{\partial^2 r}{\partial y^2} + \frac{\partial^2 r}{\partial z^2} = \frac{1}{r}$$

$$\frac{\partial^2 \theta}{\partial x^2} + \frac{\partial^2 \theta}{\partial y^2} + \frac{\partial^2 \theta}{\partial z^2} = 0$$

$$\frac{\partial^2 z}{\partial x^2} + \frac{\partial^2 z}{\partial y^2} + \frac{\partial^2 z}{\partial z^2} = 0$$

$$\left(\frac{\partial r}{\partial x} \right)^2 + \left(\frac{\partial r}{\partial y} \right)^2 + \left(\frac{\partial r}{\partial z} \right)^2 = \cos^2 \theta + \sin^2 \theta = 1$$

$$\left(\frac{\partial \theta}{\partial x} \right)^2 + \left(\frac{\partial \theta}{\partial y} \right)^2 + \left(\frac{\partial \theta}{\partial z} \right)^2 = \frac{1}{r^2}$$

$$\left(\frac{\partial z}{\partial x} \right)^2 + \left(\frac{\partial z}{\partial y} \right)^2 + \left(\frac{\partial z}{\partial z} \right)^2 = 1$$

$$\frac{\partial r}{\partial x} \frac{\partial \theta}{\partial x} + \frac{\partial r}{\partial y} \frac{\partial \theta}{\partial y} + \frac{\partial r}{\partial z} \frac{\partial \theta}{\partial z} = 0$$

$$\frac{\partial r}{\partial x} \frac{\partial z}{\partial x} + \frac{\partial r}{\partial y} \frac{\partial z}{\partial y} + \frac{\partial r}{\partial z} \frac{\partial z}{\partial z} = 0$$

$$\frac{\partial \theta}{\partial x} \frac{\partial z}{\partial x} + \frac{\partial \theta}{\partial y} \frac{\partial z}{\partial y} + \frac{\partial \theta}{\partial z} \frac{\partial z}{\partial z} = 0$$

$$\therefore \frac{\partial^2 V}{\partial x^2} + \frac{\partial^2 V}{\partial y^2} + \frac{\partial^2 V}{\partial z^2} = \frac{1}{r} \frac{\partial V}{\partial r^2} + \frac{\partial^2 V}{\partial r^2} + \frac{1}{r^2} \frac{\partial^2 V}{\partial \theta^2} + \frac{\partial^2 V}{\partial z^2} = 0$$

which is LAPLACE'S equation in cylindrical coördinates.

APPENDIX II

Elements of Vector Analysis.—Physical quantities can be divided into two large and important classes, namely: scalars and vectors.

A scalar quantity is one that is absolutely determined by its magnitude. Thus temperature, work, etc., are scalars.

A vector quantity may be defined as one having *magnitude*, *sense* and *direction* and it is necessary to specify these three in order to determine a vector. Velocities and accelerations are examples of vector quantities; forces are strictly not vectors, since they are characterized not only by their magnitude, sense and direction but also by the point of application, while vectors do not have definite position in space. However, forces can be treated as vectors when proper account is taken of this difference.

Addition and Subtraction of Vectors.—Vectors are added or subtracted by the well-known parallelogram law:

Thus

$$\mathbf{a} + \mathbf{b} = \mathbf{c}$$

and

$$\mathbf{c} - \mathbf{b} = \mathbf{a}$$

Vectors follow the associative and commutative laws of algebra, and hence very little explanation is necessary as to the addition of vectors.

The sum of three vectors \mathbf{a} , \mathbf{b} and \mathbf{c} is given by the diagonal mn as shown in Fig. 161.

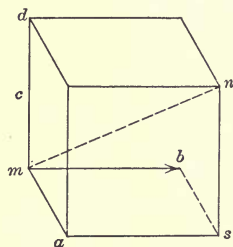

FIG. 161.

Products of Vectors.—There are two kinds of vector products:

I. The dot product which is defined as,

$$\mathbf{a} \text{ dot } \mathbf{b} = \mathbf{a} \cdot \mathbf{b} = ab \cos (a, b)$$

where \mathbf{a} and \mathbf{b} are the two vectors to be multiplied together, and a and b are the numerical values of the vectors.

II. The cross product which is defined as:

$$\mathbf{a} \text{ cross } \mathbf{b} = \mathbf{a} \times \mathbf{b} = \epsilon ab \sin (a, b).$$

where ϵ denotes that the product is a vector. It is the unit vector perpendicular to the plane formed by a and b .

The above names have been introduced by WILLARD GIBBS and they are used principally by American writers.

The reader is familiar with the resolution of vectors into components which can be treated according to the laws of ordinary algebra. The great advantage of vector analysis is that it deals with vectors directly. It is found useful, however, to resolve vectors into their components and in such case a vector a is defined in terms of its magnitude along any direction, say x , times a unit vector i along x .

For convenience rectangular coördinates are used and the unit vector along the x -axis is denoted by i , the unit vector along the y -axis is denoted by j and the unit vector along the z -axis by k .

Thus

$$a = a_x i + a_y j + a_z k$$

and

$$a = \sqrt{a_x^2 + a_y^2 + a_z^2}$$

also

$$a = a(i \cos \alpha + j \cos \beta + k \cos \gamma)$$

where α , β and γ are the direction cosines.

Now it will be easily seen from the definition of the dot product that:

$$\begin{aligned} i \cdot i &= 1 & i \cdot j &= 0 \\ j \cdot j &= 1 & i \cdot k &= 0 \\ k \cdot k &= 1 & j \cdot k &= 0 \\ a \cdot a &= a^2 \end{aligned}$$

It is also clear that the condition of perpendicularity of two vectors is that their dot product shall be zero.

The dot product is also called (by HAMILTON) the scalar product, because the product is a scalar. The cross product is called the vector product, because it is a vector.

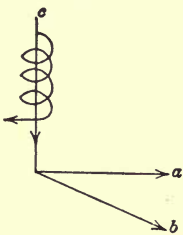

FIG. 162.

$a \times b$ gives a vector c , Fig. 162, whose magnitude is $(ab) \sin (a,b)$; its direction is along the normal to the plane of the vectors a and b , and finally the sense of c is taken so that as one goes from a to b he follows a right-hand screw. In other words from a to b we follow the threads of a corkscrew whose direction of progress determines the sense of b . This is, of course, the well-

known rule of MAXWELL for the relation between the direction of flux, the motion of a conductor, and the e.m.f. thereby generated.

It is clear from the definition of a cross product that in Fig. 163

$$i \times j = k = -j \times i$$

$$j \times k = i = -k \times j$$

$$k \times i = j = -i \times k$$

also

$$i \times i = 0 \quad j \times j = 0 \quad k \times k = 0.$$

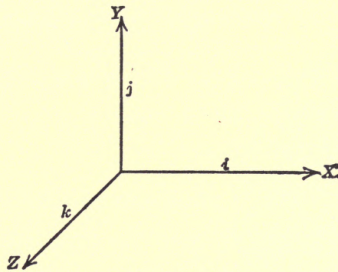

FIG. 163.

The cross product of two vectors can also be obtained in terms of the components and the unit vectors i , j and k ; only it is evident that care should be taken not to invert the order of factors, since $a \times b = -b \times a$.

Exercise.—Prove that if $a_x a_y a_z$, $b_x b_y b_z$ are the rectangular components of a and b .

$$a \times b = (a_y b_z - a_z b_y) i + (a_z b_x - a_x b_z) j + (a_x b_y - a_y b_x) k$$

or in determinant form,

$$a \times b = \begin{vmatrix} i & j & k \\ a_x & a_y & a_z \\ b_x & b_y & b_z \end{vmatrix}$$

Exercise.—Prove that the absolute value of $a \times b$ which is written $|a \times b|$

$$\begin{aligned} &= (a)(b) \sin(a, b) \\ &= \sqrt{[(a_y b_z - a_z b_y)^2 + (a_z b_x - a_x b_z)^2 + (a_x b_y - a_y b_x)^2]} \end{aligned}$$

$$a \times b = \sqrt{(a_x^2 + a_y^2 + a_z^2)(b_x^2 + b_y^2 + b_z^2) - (a_x b_x + a_y b_y + a_z b_z)^2}$$

Now it will be noticed that in the last exercise, $a_x^2 + a_y^2 + a_z^2$ is simply equal to $a \cdot a$.

Thus:

$$\begin{aligned} \text{First term} &= a \cdot a \\ \text{Second term} &= b \cdot b \\ \text{Third term} &= (a \cdot b)^2 \\ &= (ab \cos \alpha)^2 \end{aligned}$$

$$\text{where} \quad = \sphericalangle a, b$$

$$\begin{aligned} \text{so that} \quad |a \times b| &= \sqrt{(a \cdot a)(b \cdot b) - (ab \cos \alpha)^2} \\ c = a \times b &= \sqrt{a^2 b^2 - a^2 b^2 \cos^2 \alpha} \\ &= ab \sqrt{1 - \cos^2 \alpha} \\ &= ab \sin \alpha \end{aligned}$$

The product of $a \times b$, must be the normal to the plane of the vectors a and b is seen as follows: Assume c to be the vector and find $a \cdot c = a \cdot (a \times b)$

$$\text{also} \quad b \cdot c = b \cdot (a \times b)$$

Multiplying these out in the ordinary way we find

$$\begin{aligned} a \cdot c &= 0 \quad b \cdot c = 0, \\ \text{i.e.,} \quad ac \cos(a, c) &= 0 \\ bc \cos(b, c) &= 0 \end{aligned}$$

which is satisfied when c is normal to the plane ab .

The above are intended to cover the very small part of vector analysis used in this book. For further information the reader should consult special treatises written on the subject.

HEAVISIDES' "Electromagnetic Theory;" ABRAHAM and FOPPL'S "Theory of Electricity and Magnetism" can be recommended highly.

An excellent short treatise on the subject is "Elements of Vector Analysis" by BURALLI-FORTI and R. MAREOLONGO, and a somewhat larger work is that of WILLARD GIBBS, edited by WILSON. Finally COFFIN'S "Vector Analysis" may be mentioned among works of reference, it appears indeed as best suited for the introduction to vector analysis.

INDEX

- A
- Attenuation, 121
 - Austin, 316
 - Auxiliary equations, 46
- B
- Ber and bei function, 273
 - Bjerknes, 313
- C
- Capacity between concentric conductors, 70
 - between parallel planes, 68
 - between transmission lines, 70
 - of antenna, 299
 - of a single wire, 230
 - of concentric cable, 96
 - of isolated spheres, 163
 - of two cylindrical conductors, 224
 - of two wires in multiple, 230
 - Charge distribution on an ellipsoid, 199
 - Circular symmetry, 188
 - Complete differential, 164
 - Complimentary function, 46, 86
 - Concentric cylinders, 215
 - spheres, 209
 - Condenser, capacity of, 68
 - characteristics of, 68
 - charged, 71
 - discharged, 72
 - energy supplied to, 71
 - Coulomb's law, 157
 - Coupling, effect on frequency, 303
 - Curl of a vector, 257
 - Current, equation of, 261
 - Curvature of earth, 314
 - Cylindrical bars, 150
 - conductor, current and flux distribution, 268
 - conductors, 218
- D
- Differential equations, higher order, 44
 - operator, D, 45
 - Differentials and differences, 61
 - Direct-current generator, field circuit, 59
 - Displacement current, 263, 264
 - Distortionless line, 142
 - Divergence of a vector, 185
 - theorem, 186
- E
- Electric doublet, 284
 - field, energy of, 262
 - intensity, 290
 - Electromagnetic radiation, 278
 - Electromotive force, equation of, 260
- F
- Field intensity, 158
 - Flat conductors, 152
 - Flux and current distribution, 152
 - Forces between point charges and spheres, 175
 - Froelich's equation, 22
 - Fuller, 316
- G
- Gauss' theorem, 160
 - Graph of function $y = e^{-x}$, 9
 - Green's theorem, 186
 - Grounded horizontal wire, effect on potential distribution, 254

- H
- Hertz's oscillator, 284
Hysteresis loop, 56
- I
- Images, method of, 168
Inductance, 11
 of air coil, 36
 of concentric cables, 97
Inductances, combined, 37
Inductive circuit containing iron, 62
- K
- Kelvin, 273
- L
- Lame's differential parameter, 185
Laplace's equation, 188, 320
Legendre's coefficient, 188
 function, 189
Leyden jars, 72
Linear differential equations, 3
Line charge, 218
 integral, 163
Logarithmic decrement, 295
- M
- Magnetic field, energy of, 263
 energy stored in, 8
 intensity, 290
 potential, 180
 and current, 183, 184
 shell, 181
Marconi, 292
Maxwell's coefficient, 232, 263
Metallic spheres, 169
Mutual induction, 33
 imperfect, 51
 perfect, 37
- O
- Oblate ellipsoid, potential distribution, 21
204
- P
- Partial differentiation, 319
 fractions, 21
- Poisson's equation, 187
Potential, 162
 distribution between point charge and plane, 171
 between two spheres, 175
 gradient, 164, 165
 of small magnet, 180
 outside of thin circular disc, 197
Power factor, 295
 received, 317
- R
- Radiated energy, 290
Radiation, 278
 resistance, 292
Receiving station, 313
- S
- Short-circuited winding, current in, 54
Short-circuit suddenly opened, 84
Shunt motor self excited, 16
Skin effect, 271
Solenoidal field, 186
Solid angle, 183
Step-by-step method, 66
Stoke's theorem, 258
Surface density, 170
 integral of distributed vector, 158
Symbolic factors, 89
- T
- Three-phase cable, 243
Three-phase line, 249
Tuned circuit, 80
Two conductor cables, 237
- U
- Unit charge and unit pole, 157
- V
- Vector analysis, 327
Velocity of propagation, 121-132
- W
- Wave lengths, 121-132
Weber's equation, 182

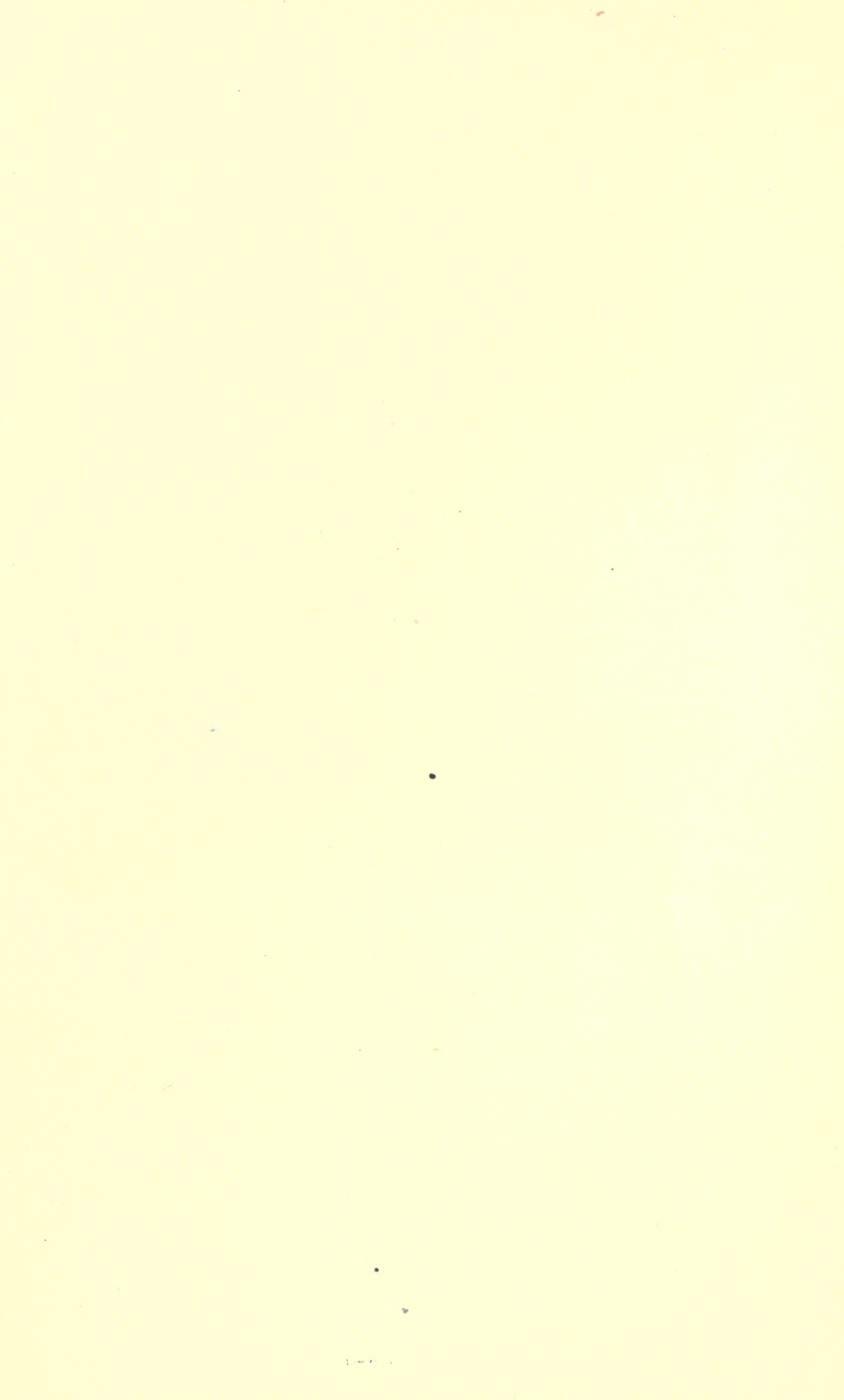

THIS BOOK IS DUE ON THE LAST DATE
STAMPED BELOW

AN INITIAL FINE OF 25 CENTS
WILL BE ASSESSED FOR FAILURE TO RETURN
THIS BOOK ON THE DATE DUE. THE PENALTY
WILL INCREASE TO 50 CENTS ON THE FOURTH
DAY AND TO \$1.00 ON THE SEVENTH DAY
OVERDUE.

OCT 23 1932
NOV 7 1932

MAR 8 1933

OCT 5 1934

SEP 3 1941

Nov 14 '48 RF

Pac. Awp. Apr 18 '49 B

INTER-LIBRARY LOAN

LD 21-50m-8,32

DEC 26 1929

YC 19681

TK 145 84283

B45

Berg

UNIVERSITY OF CALIFORNIA LIBRARY

