

INFANTRY DRILL REGULATIONS
UNITED STATES ARMY
WITH INTERPRETATIONS

U. S. Army Military History Institute
INFANTRY

DRILL REGULATIONS,

H. H. Meyer

UNITED STATES ARMY.

Gettysburg
Pa.

By Authority of the War Department.

NEW YORK:
ARMY AND NAVY JOURNAL,

D. APPLETON AND COMPANY.

PROPERTY OF HIS ARMY

UD1100
.AS
18916
0.1

UD
760
AS
1801
24

89-22

#250-1287

~~250-1367~~

Copyrighted 1881 by
W. C. & F. P. CHURCH, ARMY AND NAVY JOURNAL,
98-101 Nassau Street, New York.

89-193

WAR DEPARTMENT,
Washington, October 3, 1891.

A board of officers consisting of Lieut. Col. John C. Bates, Twentieth Infantry; Lieut. Col. George B. Sanford, Ninth Cavalry; Maj. Henry C. Hasbrouck, Fourth Artillery; Maj. John C. Gilmore, Assistant Adjutant-General; Capt. Joseph T. Haskell, Twenty-third Infantry; Capt. Edward S. Godfrey, Seventh Cavalry; and Capt. James M. Lancaster, Third Artillery, with First Lieut. George Andrews, Twenty-fifth Infantry, as recorder at first, and later, First Lieut. John T. French, jr., Fourth Artillery, having prepared a system of Drill Regulations for infantry which has been approved by the President, it is herewith published for the information and government of the Army, and for the observance of the militia of the United States.

With a view to insure uniformity throughout the Army, all infantry exercises and maneuvers not embraced in this system are prohibited and those herein prescribed will be strictly observed.

REDFIELD PROCTOR,
Secretary of War.

To this edition of the Drill Regulations have been added the sections of "Official Regulations for the Army of the United States, 1889," referred to in the text. With this exception this is an exact reproduction of the edition of the Regulations printed for the War Department at the Government Printing Office. Heretofore, on the adoption of new tactics, numerous questions as to their interpretation have arisen. Those relating to the interpretation of Casey's Tactics were answered through the ARMY AND NAVY JOURNAL by General Casey, on whose staff the Editor of the JOURNAL served during the War of the Rebellion. When Upton's Tactics were adopted questions concerning them were answered through the JOURNAL by General Upton during his lifetime. Since his death such questions have, when necessary, been referred by the Editor of the JOURNAL to the proper authorities for official determination. This practice will be continued by the ARMY AND NAVY JOURNAL in the case of such questions concerning the interpretation of these Drill Regulations as appear to require official interpretation to settle disputes.

INFANTRY

DRILL REGULATIONS.

DEFINITIONS.

Alignment—A straight line, upon which several men or bodies of troops are formed, or are to be formed.

Base—The unit on which a movement is regulated; as, *base file, company, or battalion.*

Center—The middle point or element of a command; as, the *center file, company, etc.*

Column—A formation in which the elements are placed one behind another, whether these elements are files, fours, platoons, companies or larger bodies.

Deploy—To extend the front; as, to pass from column into line.

Depth—The space from head to rear of any formation, including the leading and rear elements.

The depth of one man is taken as twelve inches.

Disposition—The distribution of the fractions of a body of troops, and the formations and duties assigned to each, for the accomplishment of a common end.

Distance—An open space in the direction of depth.

The distance between ranks in the same unit is measured from the breast of the man in rear to the back of the man in front.

The distance between two subdivisions in column is measured in like manner from guide to guide.

Between two commands in column, one in rear of the other, each comprising several fractions, the distance is measured from the rear guide of the command that is in front to the leading guide of the following command.

Drill—The exercises and evolutions taught on the drill ground and executed in the precise and formal manner prescribed.

Echelon—In the order in echelon the subdivisions are placed one behind another, extending beyond and unmasking one another, either wholly or in part.

In battle formation, this term is also employed to designate the different elements or lines in the direction of depth. Example: The *first echelon*, the firing line; the *second echelon*, the support, etc.

Evolution—A movement executed by several battalions for the purpose of passing from one formation to another.

Facing Distance—Sixteen inches; *i. e.*, the difference between the front of a man in ranks and his depth.

File—Two men, a front rank man and the corresponding man of the rear rank, whether placed one behind the other or side by side. **File Leader**—The front rank man of a file. A file is said to be blank when it has no rear rank man. When troops are in one rank, the men are frequently termed files.

File Closers—Officers, or non-commissioned officers posted two paces in rear of the line; it is their duty to rectify mistakes and to insure steadiness and promptness in the ranks.

Flank—The right or left of a command in line or column; also, the element on the right or left of a line.

In speaking of the enemy, one says "his right flank;" "his left wing," etc.; to indicate the flank or wing which the enemy would so designate.

Flank Attack—A movement made against the enemy's flank.

Flankers—Men so posted or marched as to protect the flank of a column.

Flank March—A march, whatever the formation, by which troops move along the front of the enemy's position.

Formation—Arrangement of the elements of a command. The placing of all the fractions in regular order in line, in column or for battle.

Front—The space in width occupied by a command, either in line or column.

In estimating the extent of the front, the space occupied by one man is taken at twenty-eight inches, which includes the interval between files.

Front also denotes the direction of the enemy.

Guard, Advance—A body of troops marching in front of a command to reconnoiter and to protect its march.

Guard, Rear—A body of troops to protect the rear of a command.

Guide—An officer, non-commissioned officer or private upon whom the command regulates its march.

Head—The leading element of a column.

Interval—An open space between elements of the same line.

The interval between two men is measured from elbow to elbow; between two companies, squads, etc., from the left elbow of the left man or guide of the group on the right to the right elbow of the right man or guide of the group on the left.

Left—The left extremity or element of a body of troops.

Line—A formation in which the different elements are abreast of each other. When the elements are in column the formation is called a line of columns.

Maneuver—A movement made according to the nature of the ground with reference to the position and movements of the enemy.

Order, Close—The normal formation in which soldiers are regularly arranged in line or column.

Order, Extended—The formation in which the soldiers, or the subdivisions, or both, are separated by intervals greater than in close order.

Pace—Thirty inches; the length of the full step in quick time.

In these regulations, intervals and distances that can be verified by pacing, are given in paces; those less than one pace, in inches; considerable distances, in yards.

Ploy—To diminish front; as, to ploy into close column.

Point of Rest—The point at which a formation begins.

Rank—A line of men placed side by side.

Right—The right extremity or element of a body of troops.

Scouts—Men detailed to precede a command on the march and when forming for battle, to gather and report information concerning the enemy and the nature of the ground.

Tactics—The art of handling troops in the presence of the enemy, *i. e.*, applying on the battle field the movements learned at drill.

Turning Movement—An extended movement around the enemy's flank for the purpose of threatening or attacking his flank or rear.

Wing—The portion of a command between the center and the flank; the battalion is the smallest body which is divided into wings.

SIGNALS.

The following signals are used alone or in conjunction with verbal commands or trumpet calls. The whistle call to fix the attention may precede the signal.

In making the signals, the sword, rifle or head dress may be held in the hand; when the sword is so used it is in prolongation of the arm.

Forward—Raise the arm until horizontal, extended to the front; at the same time move to the front.

Right Oblique—Raise the arm until horizontal, extended obliquely to the right; at the same time move in that direction.

Left Oblique—Same to the left.

By the Right Flank—Raise the arm until horizontal, extended to the right; at the same time move to the right.

By the Left Flank—Same to the left.

To the Rear—Face to the rear, raise the arm until horizontal, extended to the rear; at the same time move to the rear.

Change Direction to the Right or Left—Raise the arm until horizontal, extended toward the marching flank, carrying the arm horizontally to the front and right; at the same time facing and moving in the direction to be taken.

As Skirmishers—Raise both arms until horizontal, extended laterally.

Halt—Raise the arm vertically to its full extent.

Assemble—Raise the arm vertically to its full extent and slowly describe small horizontal circles.

Rally—Raise the arm vertically to its full extent and circle it very rapidly.

Cease Firing.—A whistle call. This signal is also used to fix the attention.

GENERAL PRINCIPLES.

1. All details, detachments and other bodies of troops will habitually be formed in double rank.

2. Movements that may be executed toward either flank are explained as toward but one flank, it being necessary to substitute the word "left" for "right," or the reverse, to have the command and explanation of the corresponding movement toward the other flank.

3. In movements where the guide may be either right or left, it is indicated in the command, thus: *Guide (right or left)*.

4. Any movement may be executed either from the halt, or when marching, if not otherwise prescribed.

5. All movements, not specially excepted, may be executed in double time. If the movement be from the halt, or when marching in quick time, the command *double time* precedes the command *march*; if marching in double time the command *double time* is omitted.

6. There are two kinds of commands :

The *preparatory* command, such as *forward*, indicates the movement that is to be executed.

The command of *execution*, such as MARCH, HALT or ARMS, causes the execution.

Preparatory commands are distinguished by *italics*, those of execution by CAPITALS.

Where it is not mentioned in the text who gives the commands prescribed they are the commands of the instructor.

The *preparatory* command should be given at such an interval of time before the command of execution as to admit of its being properly understood; the command of *execution* should be given at the instant the movement is to commence.

The tone of command is animated, distinct, and of a loudness proportioned to the number of men under instruction.

Each *preparatory* command is pronounced in an ascending tone of voice, but always in such a manner that the command of execution may be more energetic and elevated.

The command of *execution* is pronounced in a firm and brief tone.

When giving commands to troops it is usually best to face toward them.

7. To secure uniformity, officers and noncommissioned officers are practiced in giving commands.

8. The signal and trumpet calls should be frequently used in instruction, in order that the officers and men may readily recognize them.

9. In the different schools, the posts of the officers and non-commissioned officers are specified, but as instructors they go wherever their presence is necessary.

CLOSE ORDER.**SCHOOL OF THE SOLDIER.**

10. The object of this school is the instruction of the individual recruit and afterward that of the squad.

11. Short and frequent drills are preferable to long ones, which exhaust the attention of both instructor and recruit.

12. Generally, sergeants and corporals are the instructors under the supervision of an officer, but the captain occasionally requires the lieutenants to act as instructors.

13. The instructor will always maintain a military bearing and by a quiet, firm demeanor set a proper example to the men.

14. The instructor explains each movement in as few words as possible, at the same time executing it himself.

He requires the recruits to take by themselves the proper positions and does not touch them for the purpose of correcting them, except when they are unable to correct themselves; he avoids keeping them too long at the same movement, although each should be understood before passing to another. He exacts by degrees the desired precision and uniformity.

15. After the movements have been properly executed in the order laid down, the instructor no longer confines himself to that order.

16. As the instruction progresses the recruits will be grouped according to proficiency, in order that all may advance as rapidly as their abilities permit. Those who lack aptitude and quickness will be separated from the others and placed under experienced drill masters.

17. When the execution of a movement is improperly begun and the instructor wishes to begin it anew for the purpose of correcting it, he commands: *As you were*, at which the movement ceases and the former position is resumed.

INDIVIDUAL INSTRUCTION *without* ARMS.

18. For this instruction a few recruits, usually not exceeding four, are placed in a single rank, facing to the front, and about six inches apart, arranged according to height, the tallest man on the right.

19. To teach the recruits how to assemble, the instructor requires them to close the left hand and place the knuckles against the waist, above the hip, wrist straight, back of the hand to the front; he then places them on the same line so that the right arm of each man rests lightly against the left elbow of the man next on his right, and then directs the left hands to be replaced by the side. The men thus find themselves with an interval that allows for a free movement of the arms.

20. When the recruits have learned how to take their places, they are required to assemble without assistance. The instructor commands: **FALL IN.**

They assemble rapidly, as above prescribed, at attention, each man dropping the left hand as soon as the man next on his left has his interval.

Position of the Soldier. or Attention.

21. Heels on the same line, and as near each other as the conformation of the man permits.

Feet turned out equally and forming with each other an angle of about sixty degrees.

Knees straight, without stiffness.

Body erect on the hips, inclining a little forward; shoulders square and falling equally.

Arms and hands hanging naturally, backs of the hands outward; little fingers opposite the seams of the trousers; elbows near the body.

Head erect and square to the front; chin slightly drawn in, without constraint; eyes straight to the front.

The Rests.

22. Being at a halt, to rest the men: **FALL OUT**; or, **REST**, or **AT EASE**.

At the command *fall out*, the men may leave the ranks but will remain in the immediate vicinity.

At the command *fall in*, they resume their former places.

At the command *rest*, the men keep one heel in place, but are not required to preserve silence nor immobility.

At the command *at ease*, the men keep one heel in place and preserve silence, but not immobility.

23. To resume the attention: 1. *Squad*, 2. **ATTENTION**.

The men take the position of the soldier and fix their attention.

24. 1. *Parade*, 2. **REST**.

Carry the right foot six inches straight to the rear, left knee slightly bent; clasp the hands in front of the center of the body, left hand uppermost, left thumb clasped by thumb and forefinger of right hand; preserve silence and steadiness of position.

To resume the position of the soldier: 1. *Squad*, 2. **ATTENTION**.

To Dismiss the Squad.

25. Being in line at a halt: **DISMISSED**.

Eyes Right or Left.

26. 1. *Eyes*, 2. **RIGHT** (or **LEFT**), 3. **FRONT**.

At the command *right*, turn the head gently so as to

bring the *left* eye in line with the center of the body, eyes fixed on the line of eyes of the men in, or supposed to be in the same rank.

At the command *front*, turn the head and eyes to the front.

The instructor sees that the movement does not de-range the squareness of the shoulders.

Facings.

27. To the right or left : 1. *Right (or Left)*, 2. **FACE.**

Raise slightly the right heel and left toe and face to the right, turning on the left heel, assisted by a slight pressure on the ball of the right foot ; replace the right foot.

The facings to the left are also executed upon the left heel.

28. To the rear. 1. *About*, 2. **FACE.**

Raise slightly the left heel and right toe, face to the rear, turning to the right on the right heel and the ball of the left foot ; replace the left foot beside the right.

Salute with the Hand.

29. *Right (or Left) Hand*, 2. **SALUTE.**

Raise the right hand smartly till the forefinger touches the lower part of the head-dress above the right eye, thumb and fingers extended and joined, palm to the left, forearm inclined at about forty-five degrees, hand and wrist straight. (TWO.) (Par. 48.) Drop the arm quietly by the side. (See Par. 485.)

If uncovered, the forefinger touches the forehead above the eye.



Pl. 1, Par. 29.

SETTING UP EXERCISES.

30. In order to retain a proper set-up and to keep the muscles supple, all soldiers in garrison should be frequently practiced in the following exercises:

The *arm, hand, trunk, leg* and *foot* exercises should be alternated, the drill interrupted by frequent rests and varied by instruction in the facings, marchings, etc. While exercising one part of the body, care should be taken that the other parts remain quiet, as far as the conformation of the body will allow.

At the command *halt*, given at any time, the exercise ceases, and the position of the soldier is resumed.

The recruits being in single rank (Par. 20), the instructor will place them three paces apart.

First Exercise.

1. *Arm*, 2. EXERCISE, 3. HEAD, 4. UP, 5. DOWN, 6. RAISE.

At the command *exercise*, raise the arms laterally until horizontal, palms upward. HEAD: Raise the arms in a circular direction over the head, tips of fingers touching top of cap over the forehead, backs of fingers in contact their full length, thumbs pointing to the rear, elbows pressed back. UP: Extend the arms upward their full length, palms touching. DOWN: Force them obliquely back, and gradually let them fall by the sides. RAISE: Raise the arms laterally as prescribed for the second command. Continue by repeating, *head, up, down, raise*.

Second Exercise.

1. *Arm*, 2. EXERCISE, 3. FRONT, 4. REAR.

At the command *exercise*, raise the arms laterally, as in First Exercise. FRONT: Swing the arms, extended

horizontally to the front, palms touching, heels on the ground. **REAR**: Swing the arms extended well to the rear, inclining them slightly downward, raising the body upon the toes. Continue by repeating, *front, rear*, till the men, if possible, are able to touch the hands behind the back.

Third Exercise.

1. *Arm*, 2. **EXERCISE**, 3. **CIRCLE**.

At the command *exercise*, raise the arms laterally, as in first Exercise. **CIRCLE**: Slowly describe a small circle, with each arm upward and backward, from front to rear, the arms not passing in front of the line of the breast. Continue by repeating *circle*.

Fourth Exercise.

1. *Arm*, 2. **EXERCISE**, 3. **SHOULDER**, 4. **FRONT**, 5. **REAR**.

At the command *exercise*, raise the arms laterally, as in First Exercise. **SHOULDER**: Place the tips of fingers lightly on top of the shoulders, keeping upper arm horizontal. **FRONT**: Force the elbows to the front. **REAR**: Force the elbows back as far as possible. Continue by repeating *front, rear*.

Fifth Exercise.

1. *Hand*, 2. **EXERCISE**, 3. **CLOSE**, 4. **OPEN**.

At the command *exercise*, raise the arms laterally, as in First Exercise. **CLOSE**: Close the hands with force. **OPEN**: Open the hands quickly, spreading the fingers and thumbs apart as much as possible. Continue by repeating *close, open*.

Sixth Exercise.

1. *Forearms vertical*, 2. **RAISE**, 3. **UP**, 4. **DOWN**.

At the command *raise*, raise the forearms until nearly vertical, fingers extended and joined, palms toward

each other. **UP** : Thrust upward with force, extending the arms to their full length. **DOWN** : Force the arms obliquely back, and gradually let them fall by the sides. Continue by repeating *raise, up, down*.

Seventh Exercise.

1. *Forearms horizontal*, 2. **RAISE**, 3. **FRONT**, 4. **REAR**.

At the command *raise*, raise the forearms to the front, until horizontal, elbows forced back, hands tightly closed, backs down. **FRONT** : Thrust the arms forcibly to the front, turning the backs of the hands up, arms horizontal. **REAR** : Bring the arms back quickly to the first position, forcing elbows and shoulders to the rear. Continue by repeating *front, rear*.

Eighth Exercise.

1. *Trunk*, 2. **EXERCISE**, 3. **DOWN**, 4. **BACK**.

At the command *exercise*, raise the hands and place them on the hips, fingers to the rear, thumbs to the front, elbows pressed back. **DOWN** : Bend the trunk forward at the hips as far as possible. **BACK** : Raise and bend the trunk to the rear as far as possible. Execute both motions slowly, without bending the knees. Continue by repeating *down, back*.

Ninth Exercise.

1. *Trunk*, 2. **EXERCISE**, 3. **RIGHT**, 4. **LEFT**.

At the command *exercise*, place the hands on the hips, as in Eighth Exercise. **RIGHT** : Bend the trunk to the right, without twisting it or raising either heel. **LEFT** : Bend the trunk similarly to the left. Execute both motions slowly. Continue by repeating *right, left*.

Tenth Exercise.

1. *Trunk*, 2. **EXERCISE**, 3. **CIRCLE RIGHT** (or **LEFT**).

At the command *exercise*, place the hands on the hips,

as in Eighth Exercise. **CIRCLE RIGHT**: Bend the trunk to the right as in Ninth Exercise; turn the trunk to the rear and bend to the rear, as in Eighth Exercise; turn the trunk to the left and bend to the left, as in Ninth Exercise; turn the trunk to the front and bend forward, as in Eighth Exercise. Continue by repeating *circle right*.

Eleventh Exercise.

1. *Arms vertical, palms to the front*, 2. **RAISE**, 3. **DOWN**, 4. **UP**.

At the command *raise*, raise the arms from the sides, extended to their full length, till the hands meet above the head, palms to the front, fingers pointed upward, thumbs locked, right thumb in front, shoulders pressed back. **DOWN**: Bend over till the hands, if possible, touch the ground, keeping arms and knees straight. **UP**: Straighten the body and swing the arms, extended to the vertical position. Continue by repeating *down, up*.

Twelfth Exercise.

1. *Arms forward, palms down*, 2. **RAISE**, 3. **DOWN**, 4. **UP**.

At the command *raise*, raise the arms to the front, extended to their full length, till the hands are in front of and at the height of the shoulders, palms down, fingers extended and joined, thumbs under forefingers. **DOWN**: Bend the trunk forward at the hips as far as possible, and swing the arms backward, knees and arms straight. **UP**: Straighten the trunk and swing the arms to the forward position. Continue by repeating *down, up*.

Thirteenth Exercise.

1. *Leg*, 2. **EXERCISE**, 3. *Half bend*, 4. **DOWN**, 5. **UP**.

At the command *exercise*, place the hands on the hips as in Eighth Exercise. **DOWN**: Lower the body.

separating the knees and bending them as much as possible, heels on the ground, head and trunk erect. **UP** : Raise the body, straightening and closing the knees. Continue by repeating *down, up*.

Fourteenth Exercise.

1. *Leg*, 2. **EXERCISE**, 3. *Full bend*, 4. **DOWN**, 5. **UP**.

At the command *exercise*, place the hands on the hips as in Eighth Exercise. **DOWN** : Lower the body, separating the knees and bending them as much as possible, head and trunk erect, heels raised, weight of body resting on the balls of the feet. **UP** : Raise the body, straightening and closing the knees and lower the heels to the ground. Continue by repeating *down, up*.

Fifteenth Exercise.

1. *Leg*, 2. **EXERCISE**, 3. *Left (or right)*, 4. **FORWARD**, 5. **REAR**, or 5. **GROUND**.

At the command *exercise*, place the hands on the hips as in the Eighth Exercise. **FORWARD** : Move the left leg to the front, knee straight, so as to advance the foot about fifteen inches, toe turned out, sole nearly horizontal, body balanced on right foot. **REAR** : Move the leg to the rear, knee straight, toe on a line with the right heel, sole nearly horizontal. Continue by repeating *forward, rear*.

When the recruit has learned to balance himself, the command *forward* is followed by **GROUND**. Throw the weight of the body forward by rising on the ball of the right foot, advance and plant the left, left heel thirty inches from the right, and advance the right leg quickly to the position of *forward*. Continue by repeating *ground* when the right and left legs are alternately in the position of *forward*.

Sixteenth Exercise.

1. *Leg*, 2. **EXERCISE**, 3. **UP**.

At the command *exercise*, place the hands on the hips

as in Eighth Exercise. **UP**: Raise the left leg to the front, bending and elevating the knee as much as possible, leg from knee to instep vertical, toe depressed. **UP**: Replace the left foot and raise the right leg as prescribed for the left.

Execute slowly at first, then gradually increase to the cadence of double time. Continue by repeating *up* when the right and left legs are alternately in position.

Seventeenth Exercise.

1. *Foot*, 2. **EXERCISE**, 3. **UP**, 4. **DOWN**.

At the command *exercise*, place the hands on the hips as in Eighth Exercise. **UP**: Raise the body upon the toes, knees straight, heels together. **DOWN**: Lower the heels slowly to the ground. Continue by repeating *up*, *down*.

As soon as the exercises are well understood, they may be executed without repeating the commands. For this purpose the instructor gives the commands as prescribed, then adds: *Continue the exercise*, upon which the motions to be repeated are continuously executed until the command *halt*.

Whenever there is a regular system of gymnastic instruction it may replace the setting up exercises for well trained soldiers.

THE STEPS.

Quick Time.

31. The length of the full step in quick time is thirty inches measured from heel to heel, and the cadence is at the rate of one hundred and twenty steps per minute.

32. The recruits being confirmed in the position of the soldier, the instructor places himself eight or ten paces in front of them, and facing toward them executes the step slowly, at the same time explaining the principles; he then commands: 1. *Forward*, 2. MARCH.

At the command *forward*, throw the weight of the body upon the right leg without bending the left knee.

At the command *march*, move the left leg smartly, but without jerk, carry the foot straight forward 30 inches from the right, measuring from heel to heel, sole near the ground, knee straight and slightly turned out; at the same time throw the weight of the body forward, and plant the foot without shock, weight of body resting upon it; next, in like manner, advance the right foot, and plant it as above; continue the march, keeping the face to the front. The instructor indicates from time to time the cadence of the step by calling *one, two, three, four*; or, *left, right*, the instant the left and right foot, respectively, should be planted.

The cadence is at first given slowly, and gradually increased to that of quick time.

33. To arrest the march: 1. *Squad*, 2. HALT.

At the command *halt*, given as either foot is coming to the ground, the foot in rear is brought up and planted without shock by the side of the other.

Double Time.

34. The length of the full step in double time is 36

inches; the cadence is at the rate of 180 steps per minute.

35. To march in double time: 1. *Forward*, 2. *Double time*, 3. **MARCH**.

At the command *forward*, throw the weight of the body on the right leg; at the command *double time*, raise the hands until the forearms are horizontal, fingers closed, nails toward the body, elbows to the rear.

At the command *march*, carry forward the left foot, leg slightly bent, knee somewhat raised, and plant the foot 36 inches from the right; then execute the same motion with the right foot; continue this alternate movement of the feet, throwing the weight of the body forward and allowing a natural swinging motion to the arms. The recruits are also exercised in running, the principles being the same as for double time.

When marching in double time and in running, the men breathe as much as possible through the nose, keeping the mouth closed.

To Mark Time.

36. Being in march: 1. *Mark Time*, 2. **MARCH**.

At the command *march*, given as either foot is coming to the ground, continue the cadence and make a semblance of marching, without gaining ground, by alternately advancing each foot about half its length, and bringing it back on a line with the other.

To resume the full step: 1. *Forward*, 2. **MARCH**.

Short Step.

37. Being in march: 1. *Short Step*, 2. **MARCH**.

Take steps of fifteen inches. The full step is resumed at the commands: 1. *Forward*, 2. **MARCH**.

The length of the short step in double time is eighteen inches.

Side Step.

38. Being at a halt : 1. *Right (or Left) Step*, 2. **MARCH.**

Carry the right foot twelve inches to the right, keeping knees straight and shoulders square to the front; as soon as the right foot is planted, bring the left foot to the side of it, and continue the movement, observing the cadence for each foot, as explained for quick time.

The side step is not executed in double time.

Back Step.

39. Being at a halt : 1. *Backward*, 2. **MARCH.**

Step back with the left foot fifteen inches straight to the rear, measuring from heel to heel, then with the right, and so on, the feet alternating.

At the command *halt*, bring back the foot in front to the side of the one in rear. The back step is used for short distances only and is not executed in double time.

40. The *short step*, *side step* and *back step* may be executed from *mark time* and conversely.

Change Step.

41. Being in march : 1. *Change step*, 2. **MARCH.**

At the command *march*, given as the right foot comes to the ground, the left foot is advanced and planted; the toe of the right is then advanced near the heel of the left, the recruit again stepping off with the left.

The change on the right foot is similarly executed, the command *march* being given as the left foot strikes the ground.

Covering and Marching on Points.

42. The instructor selects two points on the ground and requires the recruits, in succession, to place themselves so that the prolongation of the straight line through these points shall pass between their heels.

The instructor places himself in the rear of each recruit, points out the faults of his position, and causes him to cover accurately.

When the recruits are able to cover the points, quickly and accurately, they are required, after covering, to march upon the points in quick and double time. The instructor remaining in rear of the recruit, observes his march; when halted, the recruit corrects his covering, if necessary; at the command *fall out*, he steps to one side. The other recruits are halted near the same point, and when all have arrived the instructor, selecting new points, continues the exercise.

Two recruits should also be established by the instructor, one covering the other, and the others required to cover them at considerable distances apart; the recruits should then be faced about and the exercise repeated in the new direction.

It should be demonstrated to the recruits that they cannot march in a straight line without selecting two points in the desired direction and keeping them covered while advancing.

43. A distant and conspicuous landmark will next be selected as a point of direction; the recruit will be required to choose two intermediate points on the ground in line with the point of direction and to march upon it by covering these points, new points being selected as he advances.

INDIVIDUAL INSTRUCTION *with* ARMS.*

44. The recruit should, as soon as possible, be taught the use of his rifle, its care and preservation.

When fair progress has been made in the Individual Instruction without Arms, the recruit will be taught the manual of arms; instruction without arms and that with arms alternating.

*For Manual for the Springfield caliber .45 see appendix, end of this volume: for Manual for the Magazine rifle see volume announced on last cover page.

Part of each drill with arms should be devoted to marching.

45. The manual of arms is explained for double rank, but for the instruction of recruits it is first executed in single rank; the instruction is given as herein prescribed, substituting the word *man* for *file* in the commands and explanations, and omitting reference to the rear rank.

At the command *fall in*, the recruits, usually not exceeding four, assemble (Par. 20), pieces at order arms.

46. To prevent accidents, the chambers will be opened (Par. 83), whenever the squad is first formed, and again just before being dismissed. *This rule is general.*

47. The cadence of the motions is that of quick time; the recruits will at first be required to give their whole attention to the details of the motions, the cadence being gradually acquired as they become accustomed to handling their arms.

The instructor will, at first, cause the men to execute the movements by themselves, without command, until they understand the details; after this he will require them to execute the movements together at command.

The movements relative to the cartridge fixing and unfixing bayonet, adjusting sight, breaking and forming stack, are executed with promptness and regularity, but not in cadence.

48. Being at a halt, the movements are, for the purpose of instruction, divided into motions and executed in detail; in this case the command of execution determines the prompt execution of the first motion and the commands, TWO. THREE, etc., that of the other motions.)

To execute movements in detail, the instructor first cautions: *By the numbers*, all movements divided into motions are then executed as above explained until he cautions: *Without the numbers*, or commands movements other than those in the manual of arms.

MANUAL OF ARMS.

General Rules.

49. 1st. In resuming the carry from any position in the manual, the motion next to the last concludes with the left hand as high as the hollow of the right shoulder, fingers extended and joined, thumb close to forefinger, back of the hand to the front, elbow close to the body, right hand embracing the guard with thumb and forefinger; the last motion consists in dropping the left hand by the side.

2d. In all positions of the left hand at the balance (center of gravity, bayonet unfixed), the thumb is extended along the stock, except at the *port* and *charge bayonet*.

3d. In all positions of the piece in front of the center of the body, the barrel is to the rear and vertical.

4th. The piece is habitually carried with the hammer at the safety notch.

50. The recruit being in the position of the soldier, the instructor will first cause him to place his piece carefully in the following positions:—

Position of Order Arms.

The butt rests evenly on the ground, arms hanging naturally, elbows near the body, right hand holding the piece between the thumb and fingers, first two fingers in front, the others in rear and opposite the seam of the trousers; this will incline the barrel forward and the toe



Pl. 2, Par. 50.



Pl. 2, Par. 50.

of the piece will be about one inch to the right and two inches to the rear of the right toe

Position of Carry Arms.



The piece is in the right hand, thumb and forefinger embracing the guard, the remaining fingers closed together and grasping the stock just under the hammer, which rests on the little finger; barrel nearly vertical and resting against the shoulder, guard to the front; arm hanging nearly at its full length, near the body.

The instructor sees that the piece at the carry is neither too high nor too low; if too high the piece will be unsteady; if too low, the right arm will become fatigued and the shoulder will be drawn down.

On first bearing arms the recruits are liable to derange their positions by lowering a shoulder or hip. The instructor endeavors to correct these faults.

Pl. 4, Par. 50.

51. Being at the order : 1. *Carry*, 2. **ARMS**.

Raise the piece vertically with the right hand, grasp it at the same time with the left, above the right, resume the carry. (TWO.) Drop the left hand.

52. Being at the carry : 1. *Order*, 2. **ARMS**.

Advance the piece, grasp it with the left hand, forearm horizontal, let go with right hand; lower the piece quickly with the left, regrasp it with the right above the balance, hand near the thigh, butt about three inches from the ground, left hand steadying the piece near the right, fingers extended and joined, forearm and wrist straight and inclined downward. (TWO.) Lower the piece gently to the ground with the right hand, drop the left by the side and take the position of order arms.

53. Being at the carry: 1. *Present*, 2. **ARMS.**

Carry the piece with the right hand, in front of the center of the body, at the same time grasp it with the left hand at the balance, forearm horizontal and resting against the body. (TWO.) Grasp the small of the stock with the right hand below and against the guard.

1. *Carry*, 2. **ARMS.**

Resume the carry. (TWO.) Drop the left hand.

54. Being at the carry or order: 1. *Right shoulder*, 2. **ARMS.**



Pl. 6, Par. 54.

Raise the piece vertically with the right hand, grasp it with the left at the balance, and raise this hand till it is at the height of the chin; at the same time embrace the butt with the right hand, toe between the first two fingers, the other fingers under the plate, barrel same inclination to the front as at the order. (TWO.) Raise the piece and place it on the right shoulder, lock plate up, muzzle elevated and inclined to the left, so that, viewed from the front, the line of the stock, from toe to guard, shall appear nearly parallel to the row of buttons; slip the left hand down to the lock plate. (THREE.) Drop the left hand by the side.

55. Being at the right shoulder: 1. *Carry*, 2. **ARMS.**

Carry the butt slightly to the left and lower the piece with the right hand; grasp it with the left at the balance, hand at the height of chin, barrel to the rear, and



Pl. 5, Par. 53.

at the same inclination to the front as at the order. (TWO.) Resume the carry. (THREE.) Drop the left hand.

56. Being at the right shoulder: 1. *Order*, 2. **ARMS**.

Take the first position of carry from right shoulder. (TWO.) Lower the piece with the left hand at the same time regrasping it with the right above the balance, and take the first position of order from carry. (THREE.) Take the position of order arms.

57. Being at the carry or order: 1. *Port*, 2. **ARMS**.

Raise and throw the piece diagonally across the body, lockplate to the front; grasp it smartly with both hands, the right, palm down at the small of stock; the left, palm up, at the balance, thumb clasping piece; barrel sloping to the left and crossing opposite the middle of left shoulder; right forearm horizontal; forearms and piece near the body.

1. *Carry*, 2. **ARMS**.

Resume the carry. (TWO.) Drop the left hand.

Being at the port: 1. *Order*, 2. **ARMS**.

Take the second and third positions of order from right shoulder.

58. Being at the right shoulder: 1. *Port*, 2. **ARMS**.

Take the first position of carry from right shoulder. (TWO.) Take the position of *port arms*.

1. *Right shoulder*, 2. **ARMS**.

Take the second and third positions of right shoulder from the carry.

The Rests.

59. *Fall out, Rest* and *At ease*, are executed as without arms.



Pl. 7, Par. 57.

On resuming the attention, take the position of order arms.

60. Being at the order: 1. *Parade*, 2. **REST**.

Carry the right foot six inches straight to the rear, left knee slightly bent, carry the muzzle in front of the center of the body, barrel to the left; grasp the piece with the left hand just above and with the right at the upper band.

1. *Squad*, 2. **ATTENTION**.

Resume the order, the left hand quitting the piece opposite the right breast.

61. To dismiss the squad, with arms: 1. *Port*, 2. **ARMS**, 3. **DISMISSED**.

62. Being at the carry:

1. *Fix*, 2. **BAYONET**.

Grasp the piece with the left hand, forearm horizontal; carry it to the left side, butt striking the ground on a line with the heels, piece inclined to the front, left wrist pressing bayonet scabbard against the thigh; carry right hand to the shank of the bayonet; draw the bayonet and fix it on the barrel, glancing at the muzzle; drop the right hand by the side.

1. *Carry*, 2. **ARMS**.

Raise the piece with the left hand and resume the carry. (TWO.) Drop the left hand.

63. Being at the carry: 1. *Unfix*, 2. **BAYONET**.

Carry the piece to the left side as in fix bayonet, and place the forefinger of the right hand against the clasp of the bayonet; unclasp the bayonet; grasp it by the shank, wrest it from the bar-



Pl. 8, Par. 60.



Pl. 9, Par. 62.

rel; glancing at the scabbard, return the bayonet, and drop the right hand by the side.

The carry arms is executed as from fix bayonet.

Bayonets are fixed and unfixed from the order, by the same commands as from the carry, the piece being shifted from the right to the left side. To return to the carry, or order; 1. *Carry*, 2. **ARMS**; or, 1. *Order*, 2. **ARMS**.

In fixing and unfixing bayonet from the order, and in returning to the order, the hands change in front of the center of the body, the left hand grasping the piece above the right.

64. Being at the port: 1. *Unfix*, 2. **BAYONET**.

As from the carry, quitting the piece with the right hand and lowering it with the left.

65. The rod bayonet is fixed and unfixed from the order only without moving the piece, grasp the roughened end of the bayonet with the thumb and forefinger of the left hand, slip the right hand to the spring button, thumb and forefinger resting on the roughened

ends; press the button, draw out (or push in), the bayonet, at the same time releasing the pressure on the spring, which will automatically catch

the bayonet; resume the position of order arms.

66. If marching, the bayonet is fixed and unfixed in the most expeditious and convenient manner.

67. Being at the carry: 1. *Charge*, 2. **BAYONET**.

Half face to the right, carrying the heel six inches to the rear and three inches to the right of the left, turn-



Pl. 10, Par. 67.

ing the toes of both feet slightly inward; at the same time drop the piece into the left hand at the balance, thumb clasping piece, elbow against the body, point of bayonet at the height of the chin, right hand grasping small of stock and supporting it firmly against the right hip, body inclining slightly forward.

1. *Carry*, 2. **ARMS.**

Resume the carry, at the same time facing to the front. (**TWO.**) Drop the left hand.

68. Being at the order: 1. *Charge*, 2. **BAYONET.**

Raise the piece with the right hand, grasp it with the left at the balance, and take the position of charge bayonet.

1. *Order*, 2. **ARMS.**

Let go the piece with the right hand and lower it with the left to the first position of order from carry, at the same time facing to the front. (**TWO.**) Resume the order.

Positions Kneeling and Lying Down.

69. The movements of kneeling, lying down and rising are first taught without arms; they are executed as with arms, except that in the position kneeling the right hand rests on the right thigh, and in moving to and from the lying position the right hand is placed on the ground; in the position lying down the forearms are against each other on the ground, left arm in front.



Pl. 11, Par. 69.

70. At the commands *kneel*, *lie down* or *rise*, the hammer will first be lowered to the safety notch, if not already there. *This rule is general.*

71. Being at the order: **KNEEL.**

Each front rank man half faces to the right, carrying



Pl. 12, Par. 71.

right foot so that the toe shall be about ten inches to the rear and ten inches to the left of left heel; kneel on right knee, bending the left, left toe slightly inclined to the right, right leg pointing directly to the right; weight of body resting on right heel; place left forearm across left thigh, hand hanging naturally; the piece remains in the position of order arms, right hand grasping it above the balance. *This is the position of order kneeling.*

Each rear rank man steps off obliquely to the right with the left foot, planting the toe opposite the middle of the interval to his right and in line with the left heel of his front rank man, at the same time placing the butt of his piece against his left toe; he then kneels as prescribed for the front rank.

72. Being at the order kneeling: **RISE.**

Rise and take the position of order arms; the rear rank men covering their file leaders.

73. Being at the order kneeling: **LIE DOWN.**

Each front rank man places the right knee against the left heel. (**TWO.**) Draw back the left foot and place the knee on the ground; place the left hand well forward on the ground and lie flat on the belly, thus inclining the body about thirty-five degrees to the right; the piece is lowered at the same time with the right hand, toe resting on the ground, barrel up, left hand at the bal-



Pl. 13 Par. 73.

ance, left elbow on the ground, right hand at the small of the stock, opposite the neck. *This is the position lying down.*

The rear rank men move back one pace and lie down as prescribed for the front rank.

74. Being in position lying down : RISE.

Reverse the second motion of lie down. (Par. 73.) (TWO.) Rise as from the order kneeling. (Par. 72.)

75. Being at the order standing : LIE DOWN.

Each front rank man takes the position of order kneeling, except that the right knee is placed against the left heel. (TWO.) Execute the second motion of lie down. (Par. 73.)

The rear rank men step back one pace and lie down as prescribed for the front rank.

76. Being in position lying down : KNEEL.

Execute the first motion of rise (Par. 74) and take the position of order kneeling.

To Load.

77. Being in line, standing at the carry or order : LOAD.

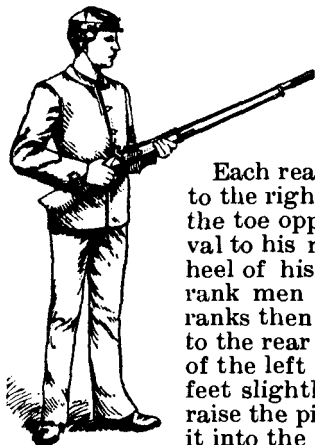

Each rear rank man steps off obliquely to the right with the left foot, planting the toe opposite the middle of the interval to his right and in line with the left heel of his front rank man; the front rank men half face to the right; both ranks then carry the right heel six inches to the rear and three inches to the right of the left heel, turning the toes of both feet slightly inward, at the same time raise the piece with the right hand, drop it into the left at the balance, muzzle at the height of the chin, left elbow against the body, small of the stock at the waist; place the

Pl. 14, Par. 77.

right thumb on the head of the hammer, forefinger on the trigger, the other fingers against the small of the stock, and half cock the piece, lower the muzzle, barrel sloping downward at an angle of about twenty-five degrees, at the same time open chamber; look toward the chamber, remove the cartridge shell if necessary; take a cartridge between the thumb and first two fingers, place it in the bore, pressing it home with the thumb; close chamber with the right thumb, cast the eyes to the front, carry the right hand to the small of the stock and raise the muzzle to the height of the chin. *The last position is the position of load.*

78. If kneeling, the left forearm rests across the left thigh. If lying down the left hand steadies the piece, toe resting on the ground.

79. Boxes are closed after executing the order or order kneeling.

80. Being in the position of load: 1. *Squad*, 2. **READY.**

Cock the piece with the right thumb, and return the thumb to the small of the stock.

81. The piece may be brought to a ready from any position by the same commands; in executing it, first take the position of load. (Pars. 77 and 78.)

82. Being in position of load or ready: 1. *Order*, 2. **ARMS.**

Lower the hammer to the safety notch, and take the order as from charge bayonet; the rear rank men then step back and cover their file leaders. If kneeling, lower the hammer to the safety notch and take the order kneeling.

83. To ascertain if any of the pieces are loaded, the instructor causes them to be brought to the port and commands: 1. *Open*, 2. **CHAMBER.**

Half cock the piece, open chamber, and return the hand to the small of the stock.

Each man, as soon as his piece is examined, closes chamber with the right thumb, lowers the hammer to the safety notch, and returns the hand to the small of

the stock. If the instructor does not examine the pieces, he commands : 1. *Close*, 2. **CHAMBER** ; at which chambers are closed, hammers lowered to safety notch and the port resumed.

84. Being in any position, pieces loaded : 1. *Draw*, 2. **CARTRIDGE**.

Executed as prescribed for loading (Pars. 77 and 78), except that the cartridge is withdrawn and returned to the box or belt, and the hammer lowered to the safety notch.

To Aim and Fire.

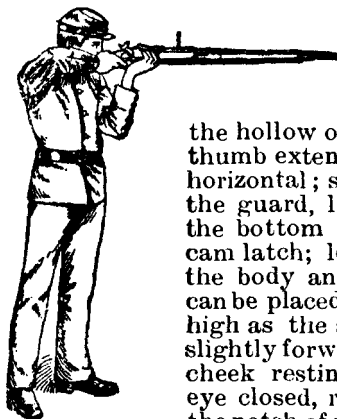

Pl. 15, Par. 85.

85. Being at the ready:

AIM.

Raise the piece with both hands and support the butt firmly against the hollow of the right shoulder, right thumb extended along the stock, barrel horizontal ; slip the left hand back to the guard, little finger resting against the bottom of the thumb piece of the cam latch ; left elbow resting against the body and as far to the right as it can be placed with ease, right elbow as high as the shoulder ; incline the head slightly forward and a little to the right, cheek resting against the stock, left eye closed, right eye looking through the notch of rear sight, so as to perceive the top of the front sight ; second joint

of forefinger resting lightly against the front of the trigger, but not pressing it.

Each rear rank man aims through the interval at the right of his file leader, and inclines slightly forward, to advance the muzzle of his piece beyond the front rank. When lying down in double rank, the rear rank men do not aim nor fire.

86. FIRE.

Press the finger against the trigger; fire without deranging the aim and without lowering or turning the head.



Pl. 16, Par. 90.

87. LOAD.

Lower the piece and load. (Par. 77.)

88. The exercise is continued by the commands:

1. *Squad*, 2. **READY**, 3. **AIM**, 4. **FIRE**, 5. **LOAD**.

89. To accustom the recruits in the position of aim, to wait for the command *fire*: 1. *Recover*, 2. **ARMS**.

At the command *recover*, withdraw the finger from the trigger; at the command *arms*, take the position of ready.

90. In aiming kneeling, the left elbow rests upon the left knee, point of elbow in front of



Pl. 17, Par. 90.

knee cap.

In aiming lying down, raise the piece with both hands and slip it through the left to the lock plate; rest on both elbows and press the butt firmly against the right shoulder; in recovering arms, the piece is held as in load.

91. When the recruits are thoroughly instructed in the adjustments of the sight, and the principles of aiming as laid down in the *Firing Regulations for Small Arms*, they will be required to aim, using the different lines of sight. For this purpose the instructor commands: 1. *At* (so many, *yards*, 2. *Squad*, 3. **READY**, 4. **AIM**.

At the first command, both ranks take the position for loading and adjust the sight with the right hand; then raise the muzzle to the height of the chin.

The instructor assures himself by careful inspection that each man sets his sight at the range indicated; when satisfied that the subject is fully comprehended, he will exercise the men in aiming at a designated object. For this purpose he commands: 1. *At that tree* (or *At ———*), 2. *At* (so many) *yards*, 3. *Squad*, 4. **READY**, 5. **AIM**.

At the first command, fix the eyes on the object indicated; at the second command, adjust the sight and immediately fix the eyes upon the object again.

92. In order not to mislead the men, the distance announced in the command should be, as nearly as possible, the true distance of the objective. By changing the objective, all the different lines of sight may be used; the men should be practiced in aiming at objects above and below them.

93. The recruits are at first taught to load and fire without using cartridges; after a few lessons, they should use dummy cartridges, and when well instructed the drill may close with a few rounds of blank cartridges.

94. No cartridges will be used, except when indicated in the first command, thus: 1. *With dummy (blank or ball) cartridges*, 2. **LOAD**. *This rule is general.*

Rifle Salute.

95. Being at the carry: 1. *Rifle*, 2. **SALUTE**.

Carry the left hand smartly to the hollow of the right shoulder, forearm horizontal, palm of the hand down, thumb and fingers extended and joined, forefinger against the piece. (TWO.) Drop the left hand by the side.



Pl. 18, Par. 95.

Inspection of Cartridge Boxes and Arms.

96. Being at the order : 1. *Open*, 2. **BOXES.**

Steady the piece by grasping it with the left hand near the muzzle, forearm horizontal ; open the box with the right hand and resume the order.

In a similar manner each man, as his box is inspected, closes it and resumes the order.

97. Being at the order : 1. *Inspection*, 2. **ARMS.**

At the command *arms*, bayonets are fixed and cartridge boxes opened.

Each man, as the inspector approaches him, executes *port arms* and *open chamber*.

The inspector takes the piece (the man dropping the hands by the sides), inspects and hands it back to the man, who receives it with the left hand at the balance, resumes the *port*, closes chamber, brings the hammer to the safety notch, unfixes bayonet and returns to the order.

With the ramrod bayonet, the piece is brought to the order and the bayonet is then unfixes.

As the inspector returns the piece, the next man executes *inspection arms*, and so on through the squad.

Should the piece be inspected without handling, the man closes chamber, brings the hammer to the safety notch, unfixes bayonet and returns to the order, when the inspector passes to the next man who immediately executes *inspection arms*.

The inspection of arms begins on the right, after which the inspector may pass in rear and inspect boxes from left to right.

Boxes are closed as soon as inspected.

To Unsling and Sling Knapsacks.

98. Arms being stacked : 1. *Unsling*, 2. **KNAPSACK.**

At the command *unsling*, the front rank moves back one step (Par. 39) to clear the stacks, and faces about;

the rear rank at the same time moves back three steps; all the men unhook the right hand strap.

At the command *knapsack*, remove the knapsacks, the four men whose pieces are in the same stack leaning their knapsacks, flaps outward, one against another in the form of a square.

The knapsacks of the guides and file closers are placed each against the nearest pile.

1. *Sling*, 2. **KNAPSACK.**

At the command *sling*, each man takes his knapsack and, standing erect, holds it by the straps, the flap next to the knees; at the command *knapsack*, places the knapsack on the back, the front rank facing about and stepping up to the stacks, the rear rank closing to facing distance.

NOTE.—The word *knapsack* will be used in the commands for all patterns of packs.

STACK ARMS.

99. Stacks will not be made with the bayonet if the rifles have the stacking swivel.

100. Three pieces only are used in making a stack; pieces not so used are, in this connection, termed *loose pieces*.

Preparatory to stacking arms, the squad must have counted fours (Par. 186), and must be in line at the order.

With the Stacking Swivel.

101. 1. *Stack*, 2. **ARMS.**

At the command *stack*, each even number of the front rank raises his piece with the right hand, grasps it with the left at the upper band, and rests the butt between his feet, barrel to the front, muzzle inclining slightly to the front and opposite the center of the interval on his right, the thumb and forefinger raising the stacking swivel; each even number of the rear rank then passes his piece, barrel to the rear, to his file leader, who grasps it between the bands with his right hand and

throws the butt twenty-eight inches in advance of his own and opposite the middle of the interval, the right hand slipping to the upper band, the thumb and forefinger raising the stacking swivel, which he engages with that of his own piece; each odd number of the front rank raises his piece with the right hand, barrel to the front, the left hand guiding the stacking swivel, which he holds near the stacking swivel of the other pieces.

At the command *arms*, each odd number of the front rank engages the lower hook of his swivel with the free hook of the swivel of the even number of the rear rank; he then turns the barrel outward and downward, into the angle formed by the other two pieces, and rests the butt between his feet.

The stacks being formed, the pieces of the odd numbers in the rear rank are passed to the even numbers in the front rank, who lay them on the stacks. The pieces of the guides and the file closers are laid on the stacks at the same time.

The men having quitted their pieces, take the position of the soldier.

The instructor may then rest or dismiss the squad, leaving the arms stacked.

On assembling, the men take their places in rear of the stacks.

102. 1. *Take*, 2. **ARMS**.

At the command *take*, the loose pieces are returned; each even number of the front rank then grasps his own piece with the left hand, the piece of his rear rank man with the right hand, grasping both between the bands; each odd number of the front rank grasps his piece in the same way with the right hand.

At the command *arms*, each odd number of the front rank disengages his own piece by turning it to the right; each even number of the front rank disengages his piece by turning it to the left; the butts are then raised

from the ground, each even number of the front rank passes the piece of his rear rank man to him, and all resume the order.

With the Bayonet.

103. 1. *Stack*, 2. **ARMS.**

At the command *stack*, each even number of the front rank raises his piece with the right hand and grasps it with the left between the bands and holds the butt six inches above the space between his feet, barrel to the rear, muzzle inclining slightly to the front and opposite the center of the interval on his right; each even number of the rear rank then passes his piece, barrel to the right, to his file leader, who grasps it between the bands with his right hand and places the shank of the bayonet upon that of his own; each odd number of the front rank raises his piece with the right hand, barrel to the front, and places the shank of his bayonet in the angle formed by the bayonets of the other two pieces; the butts of all the pieces are about six inches from the ground.

At the command *arms*, each even number of the front rank, with his right hand, passes the butt of the piece of his rear rank man twenty-eight inches in advance of his own and opposite the middle of the interval, passing it between the butts of the other pieces; the stack is then lowered, the front rank men resting the butts of their own pieces between their feet.

The stacks being formed, the pieces of the odd numbers of the rear rank are passed to the even numbers of the front rank, who lay them on the stacks. The pieces of the guides and file closers are laid on the stacks at the same time.

The men having quitted their pieces take the position of the soldier.

104. 1. *Take*, 2. **ARMS.**

At the command *take*, the loose pieces are returned;

each even number of the front rank then grasps his own piece with the left hand, the piece of his rear rank man with the right hand, grasping both between the bands; each odd number of the front rank grasps his own piece in the same way with the right hand.

At the command *arms*, raise the butts from the ground and disengage the pieces; each even number of the front rank passes the piece of his rear rank man to him, and all resume the order.

105. Being in single rank, arms are stacked and taken on the same principles as in double rank; at the preparatory command number three steps back and covers number two; numbers two and three execute what has been explained for the even numbers of the front and rear rank respectively; number three then resumes his place; number one uses his piece as explained for the odd number of the front rank. The piece of number four is passed as explained for the odd numbers of the rear rank.

106. The following positions of the piece are intended mainly for use in extended order and route marches. Whenever the commands for any of these positions are given, the piece will be shifted in the most convenient manner; reducing the movements to regular motions and cadence is prohibited.

107. 1. *Trail*, 2. *ARMS*.

The piece is grasped with the right hand, just above the balance, right arm slightly bent, barrel up, muzzle inclined slightly to the front.

When it can be done without danger or inconvenience to others, as on the firing line, the piece may be grasped at the balance and the muzzle lowered until the piece is horizontal. A similar position in the left hand may then be used.

108. 1. *Left shoulder*, 2. *ARMS*.

The piece rests on the left shoulder, barrel up, muzzle elevated so as not to interfere with the men in rear, trigger guard in front of and near the shoulder, left hand

embracing the butt, heel between the first and second fingers, elbow down.

109. 1. *Sling*, 2. ARMS.

The right arm is passed between the rifle and the sling which rests upon the shoulder, piece in rear of the shoulder and nearly vertical, muzzle up; right hand steadying the piece.

On route marches, the piece may be slung on the left shoulder. The gun sling should never be so tightly drawn that it cannot be readily adjusted.

110. 1. *Secure*, 2. ARMS.

The piece is held in the right hand at the balance, barrel up, sloping downward and to the front; right hand supported against the front of the hip, upper arm against the stock. A corresponding position in the left hand may be used.

111. When the recruits are at first exercised in marching with arms, the instructor orders the pieces into position before putting the squad in march and before passing from

quick to double time; he also causes the recruits to be at quick time at the carry before ordering the halt.

112. When the marchings and manual of arms are thoroughly understood, the following general rules govern:

1st. If at the order, bring the piece to the right shoulder at the preparatory command for marching in quick time.



Pl. 20, Par. 110.



Pl. 19, Par. 109.

2d. If at the order or carry, bring the piece to the right shoulder at the command: *Double time.*

3d. A disengaged hand in double time is held as when without arms.

4th. If at the right shoulder, left shoulder, or trail, bring the piece to the order on halting; the execution of the order and halt commence at the same instant.

5th. When the facings, side step, back step, alignments, open and close ranks, and loadings are executed from the order, raise the piece to the trail while in motion, and resume the order on halting. When this rule applies to other movements, it is therein stated.

113. In the battle exercises, or whenever circumstances require, the regular positions of the manual of arms and the firings may be ordered without regard to the previous position of the piece; such movements as are not in the manual will be executed without regard to motions or cadence. It is laid down as a principle that the effective use of the weapon is not to be impeded by the formalities of drill.

THE SQUAD.

114. The movements are explained for double rank, with arms; in the instruction of recruits, however, the movements are first executed in single rank, without arms; the instruction is given as herein prescribed by substituting the word *man* for *file* in the commands and explanations, and omitting reference to the rear rank and the position of the piece.

115. The recruits are divided into groups of about seven men, to represent squads, each under the command of a corporal, who is the instructor. (Par. 12.)

The object is to give the corporal the confidence and experience necessary to qualify him as squad leader,

while at the same time teaching the recruits the movements in close and extended order.

The corporal, as squad leader, is posted as the left man in the front rank. (See Par. 9.) The rear rank man, who covers the corporal, steps into the front rank whenever the latter leaves his place; this file remains blank until the corporal resumes his place in ranks.

116. When the guide is announced in the command, the man on the designated flank conducts the march, but in no other respect acts as guide.

To accustom the recruits to their duties in all positions their places will frequently be changed.

117. A double or single rank faced to a flank is called a column of files. (See, also, Par. 215.)

118. In line, the distance between ranks, from back to breast, is facing distance; on rough ground, and when marching in double time, it is increased to 36 inches; the rear rank closes to facing distance upon halting.

When the knapsack is worn, the distance is increased by the depth of the knapsack.

To Size and Form the Squad.

119. Being in single rank at the order, the instructor faces the squad to the right, arranges the men according to height, tallest man in front, and commands: 1. *In two ranks form squad*, 2. MARCH, 3. FRONT.

At the command *march* the first man faces to the left; the second man places himself in the rear rank covering the first; both place the left hand above the hip (Par. 19); the other men close in quick time, and form alternately in front and rear rank, as explained for the first two, each man facing to the left upon arriving at his proper place; then dressing to the right.

All the men having formed, the instructor com-

mands: **FRONT**. The men turn the head and eyes to the front and drop the left hand by the side.

The squad having been sized, the men are cautioned to take the same relative positions, when the squad is formed thereafter.

120. To form the squad, the corporal places himself in front of where the center is to be formed, makes the signal for the assembly, or commands: **FALL IN**.

The men assemble in their proper places in double rank; arms at the order.

Alignments.

121. The alignments are first taught by requiring the recruits to align themselves, man by man, upon two files established as a base.

Being at the carry or order: 1. *Two files from the right (or left) three paces to the front*, 2. **MARCH**, 3. **NEXT**, 4. **FRONT**.

At the command *march*, the first two files on the right march three paces to the front, halt, execute *eyes right*, and place the left hand above the hip (Par. 19); the instructor aligns them, sees that the rear rank men cover their file leaders, and then causes the remaining files to move up successively on this alignment, each by the command *next*.

At the command *next*, the next file marches three paces to the front, each man shortening the last step so as to find himself about six inches in rear of the new alignment, which must never be passed; he then executes *eyes right*, places the left hand above the hip, and taking steps of two or three inches, moves up, placing his arm lightly against the elbow of the man on his right, so that his eyes and shoulders shall be in line with those of the men on his right.

The instructor sees that each *man* observes the principles of the alignment, and when the last file has

arrived on the line, verifies the alignment of both ranks from the right flank and orders up or back, such men as may be in rear or in advance of the line; only the men designated move.

At the command *front*, given when the ranks are aligned, the men cast their eyes to the front and drop the left hand; all movement in the ranks must then cease.

In dressing to the left, each man places himself so that his left elbow touches lightly the arm of the man on his left.

122. In the first drills, the basis of the alignment is established parallel to the front of the squad, and afterward in oblique directions.

In order to habituate the recruit to his interval in line, the left hand is placed above the hip in all alignments in the School of the Soldier.

123. The recruits having learned to align themselves, man by man, the instructor establishes the base files and aligns the squad by the commands: 1. *Right (or left)*, 2. **DRESS**, 3. **FRONT**.

At the command *dress*, all the men except the base files, move forward and dress up to the line, as previously explained.

The rear rank men cover in file, at facing distance, and cast their eyes to the right.

The instructor verifies the alignment and gives the command: *Front*. All the men then turn the head and eyes to the front and drop the left hand.

124. Alignments to the rear are executed on the same principles: 1. *Right (or left) backward*, 2. **DRESS**, 3. **FRONT**.

The men step back, halt a little in rear of the line of the base files, and immediately dress up by steps of two or three inches.

125. To execute the alignments, using the side step, the instructor establishes the base files a few paces to the right or left of the squad and commands: 1. *Right (or left) step*, 2. *Right (or left)*, 3. **DRESS**, 4. **FRONT**.

At the command *dress*, the men execute the side step, close toward the base files, and dress as already explained.

126. When the squad dresses quickly and well, the guide alone is first established.

In dressing, the first two or three files are accurately aligned as quickly as possible, to afford a base for the rest of the squad.

MARCHINGS.

To March in Line.

127. Being in line at a halt: 1. *Forward*, 2. *Guide (right or left)*, 3. **MARCH.**

The men step off, the guide marching straight to the front; the rear rank men cover their file leaders and follow them at facing distance.

The instructor sees that the men preserve the interval toward the side of the guide; that they yield to pressure from that side and resist pressure from the opposite direction; that by slightly shortening or lengthening the step, they gradually recover the alignment, and by slightly opening out or closing in, they gradually recover the interval, if lost; that while habitually keeping the head to the front, they may occasionally glance toward the side of the guide to assure themselves of the alignment and interval, but that the head is turned as little as possible for this purpose.

To change the guide: *Guide (left or right)*.

128. If the men lose step, the instructor commands: **STEP.**

The men glance toward the side of the guide, retake the step and cast their eyes to the front.

To March Backward.

129. Being at a halt: 1. *Backward*, 2. *Guide (right or left)*, 3. **MARCH.**

To March to the Rear.

130. Being in march : 1. *To the Rear*, 2. **MARCH**, 3. *Guide (right or left)*.

At the command *march*, given as the right foot strikes the ground, advance and plant the left foot; then turn on the balls of both feet, face to the right about and immediately step off with the left foot.

If marching in double time, turn to the right about, taking four short steps in place, keeping the cadence, and then step off with the left foot.

To March by the Flank, in Column of Files.

131. Being in line at a halt : 1. *Right (or left)*, 2. **FACE**, 3. *Forward*, 4. **MARCH**.

If marching : 1. *By the right (or left) flank*, 2. **MARCH**.

At the command *march*, given as the right foot strikes the ground, advance and plant the left foot, then face to the right in marching and step off in the new direction with the right foot.

In each file the front rank man is the guide; the men cover in file and keep closed to facing distance.

To halt the column of files : 1. *Squad*, 2. **HALT**; and to face it to the front : 3. *Left (or right)*, 4. **FACE**.

Marching in Column of Files, to March in Line.

132. 1. *By the right (or left) flank*, 2. **MARCH**, 3. *Guide (right or left)*.

To Change Direction in Column of Files.

133. Being in march : 1. *Column right (or left)*; or, 1. *Column half right (or half left)*, 2. **MARCH**.

The leading file wheels to the right, the pivot man shortening two or three steps and moving over a quarter, or an eighth of a circle, whose radius is about eighteen inches; the other files follow the first and wheel on the same ground.

If at a halt: 1. *Forward*, 2. *Column right* (or *left*), 3. **MARCH**; or, 2. *Column half right* (or *half left*), 3. **MARCH**.

The Oblique March.

134. For the instruction of recruits, the squad being correctly aligned, the instructor will face the squad half right or half left, point out to the men their relative positions and explain that these are to be maintained in the oblique march.

135. Being in line at a halt, or marching: 1. *Right* (or *left*) *oblique*, 2. **MARCH**.

Each man half faces to the right, at the same time stepping off in the new direction. He preserves his relative position, keeping his shoulders parallel to those of the man next on his right, and so regulates his step as to make the head of this man conceal the heads of the other men in the rank; the ranks remain parallel to their original front.

The rear rank conforms to the foregoing, each man marching so as to cover his file leader upon resuming the original direction.

At the command *halt*, the men halt, faced to the front.

To resume the original direction: 1. *Forward*, 2. **MARCH**.

The men half face to the left in marching and then move straight to the front.

If marking time while obliquing, the oblique march is resumed by the commands: 1. *Oblique*. 2. **MARCH**.

The short step will not be used in the oblique march.

136. In the oblique march, the guide is always without indication, on the side toward which the oblique is made. On resuming the direct march the guide is without indication on the side it was previous to the oblique.

If the oblique be executed from a halt, the guide is announced on taking the direct march in line.

These rules are general.

137. The column of files obliques by the same commands and means.

To March in Double Time.

138. Being in line at a halt: 1. *Forward*, 2. *Guide* (*right* or *left*), 3. *Double time*, 4. **MARCH**.

To Pass from Quick to Double Time and the Reverse.

139. 1. *Double time*, 2. **MARCH**.

At the command *march*, given as the left foot strikes the ground, advance the right foot in quick time, and step off with the left foot in double time.

To resume quick time: 1. *Quick time*, 2. **MARCH**.

At the command *march*, given as either foot is coming to the ground, the squad resumes quick time.

TURNINGS.

To Turn and Halt.

140. Marching in line: 1. *Squad right* (or *left*), 2. **MARCH**, 3. **FRONT**.

At the command *march*, the right file halts and the front rank man or pivot faces to the right; the other files half face to the right in marching, and without changing the length or cadence of the step place themselves successively upon the alignment established by the right file; all dress to the right without command. The instructor verifies the alignment from the pivot flank and commands: **FRONT**.

The rear rank men conform to the movements of their file leaders.

If at a halt, the movement is executed in the same manner; if at the order and the movement is executed in quick time, the pieces are held at the trail while in motion.

Squad half right (or *half left*) is executed in the same manner, except that the pivot makes a half face to the right.

To Turn and Advance.

141. Marching in line: 1. *Right* (or *left*) *turn*, 2. **MARCH**, 3. *Forward*, 4. **MARCH**, 5. *Guide* (*right* or *left*).

At the second command, the front rank man on the right, who is the guide, marches by the right flank, taking the short step without changing the cadence; the other men half face to the right in marching, and moving by the shortest line successively place themselves on the new line, when they take the short step.

The rear rank men conform to the movements of their file leaders. When the last man has arrived on the new line, the fourth command is given, when all resume the full step.

During the turn, the guide is without command on the pivot flank. The guide is announced on resuming the full step.

If at a halt, the movement is similarly executed, and in quick time, unless the command *double time* be given.

Right (or *left*) *half turn* is executed in the same manner, except that the guide makes a half face to the right.

Should the command *halt* be given during the execution of the movement, those men on the new line halt; the others halt on arriving on the line; all dress to the right without command.

The instructor verifies the alignment from the pivot flank and commands: **FRONT**.

FIRINGS.

142. The post of the instructor is three paces in rear of the squad, but in actual firing he places himself where he can best make himself heard and at the same time observe the effect of the fire; the objective should be in plain view and so designated as to be easily distinguished by all.

143. The commands for firing are the same whether the squad be standing, kneeling or lying down. The

commands for kneeling or lying down precede the commands for firing.

144. At the preparatory command for firing, the squad being in line standing, the rear rank men close, as explained for loading (Par. 77); and the cartridge box if worn is slipped to the hip and opened; it is closed and replaced after executing *cease firing*.

Volley Firing.

145. The squad being in line fronting the object to be fired upon, pieces loaded: 1. *Fire by squad*, 2. *At* (such an object), 3. *At* (so many) *yards*, 4. *Squad*, 5. **READY**, 6. **AIM**, 7. **FIRE**, 8. **LOAD**.

To fire another volley at the same objective with the same line of sight: 1. *Squad*, 2. **READY**, 3. **AIM**, 4. **FIRE**, 5. **LOAD**.

To fire another volley at the same objective but with a new line of sight: 1. *At* (so many) *yards*, 2. *Squad*, 3. **READY**, 4. **AIM**, 5. **FIRE**, 6. **LOAD**.

To fire another volley at a new objective and with a new line of sight: 1. *At* (such an object), 2. *At* (so many) *yards*, 3. *Squad*, 4. **READY**, 5. **AIM**, 6. **FIRE**, 7. **LOAD**.

146. The objective and range will be indicated in the preparatory commands for all kinds of fire, as illustrated in the preceding examples.

If the objective be at a considerable angle to the front of the squad the instructor will change the front of the squad so as to face it.

The commands are given at sufficient intervals to allow them to be executed as already prescribed. The command *fire* is given when the pieces appear to be steady.

These rules are general.

To Cease Firing.

147. **CEASE FIRING.**

The men stop firing, draw cartridge or eject the empty

shell, lower the sight leaf and take the order, order kneeling or the position lying down, as the case may be. If standing the rear rank men then step back and cover their file leaders.

148. The command (or signal) *cease firing*, is always used to stop the firing and may be given at any time after the first preparatory command for firing, whether the firing has actually commenced or not. *This rule is general.*

149. 1. **CEASE FIRING**, 2. **LOAD**.

The firing will stop; such pieces as are already loaded will be brought at once to the position of load; the others will be loaded.

This is intended to interrupt the firing, for the purpose of steadying the men, or to change to another method of firing.

To Fire at Will.

150. 1. *Fire at will*, 2. *At* (such an object), 3. *At* (so many) *yards*, 4. *Squad*, 5. **READY**, 6. **COMMENCE FIRING**.

At the command *commence firing* each man independently of the others takes careful aim at the object, fires, loads and continues the fire as rapidly as is consistent with taking careful aim at each shot. The men should be taught to load rapidly and to aim deliberately.

BAYONET EXERCISE.

151. The object of this drill is to make the soldier quick and proficient in handling his piece.

It is intended merely to prescribe the manner of executing the movements laid down, but not to restrict the number of movements, leaving to the discretion of company commanders and the ingenuity of instructors the selection of such other exercises as accord with the object of the drill.

As soon as the movements are executed accurately, the commands are given rapidly; expertness in the bayonet exercise depending mostly on quickness of motion.

152. In taking intervals and distances, the normal interval and distance when armed is four paces; when unarmed, two paces.

To Take Intervals.

153 Being in line at a halt: 1. *To the right* (or *left*) *take intervals*, 2. **MARCH.**

At the first command, the rear rank steps back four paces; at the command *march*, the man on the left of each rank stands fast; the other men face to the right and step off, each man halting faced to the front, when he has the proper interval.

To Assemble.

154. 1. *To the right* (or *left*) *assemble*, 2. **MARCH.**

The front rank man on the right stands fast; the other men close to their proper places.

To Take Distances.

155. Being in line at a halt, and having counted fours: 1. *Front take distance*. 2. **MARCH.**

Number one of each four of the front rank moves

straight to the front; number two moves off as soon as number one has advanced the specified distance; numbers three and four move off in succession in like manner. The rear rank executes what has been prescribed for the front rank, number one moving off as soon as number four front rank has advanced four paces. The proper distance being attained: 1. *Squad*, 2. HALT.

To Assemble.

156. 1. *Assemble*, 2. MARCH.

Number one of the front rank stands fast; the other men move forward and close to their proper places.

157. Intervals or distances having been taken and the squad being at the carry or order with bayonets fixed:

Bayonet exercise, 2. GUARD.

At the command *guard*, half face to the right, carry



back and place the right foot about twice its length to the rear and three

inches to the right, the feet at little less than a right angle, the right toe pointing squarely to the right, both knees bent slightly, weight of the body held equally on both legs; at the same time throw the point of the bayonet to the front, at the height of the chin, barrel turned slightly to the left, grasping the piece lightly with both hands, the right at the small of the stock, the left between lower band and

Pl. 21, Par. 157.

lock plate; the right hand in line with the left hip and at the height of the belt, both arms held free from the body and without constraint.

158. 1. *Carry*, 2. **ARMS**; or, 1. *Order*, 2. **ARMS**.

Resume the carry or order as for charge bayonet.

159. Being at the guard: **ADVANCE**.

Move the left foot quickly forward, twice its length; follow with the right foot the same distance.

160. **RETIRE**.

Move the right foot quickly to the rear, twice its length; follow with the left foot the same distance.

161. 1. *Front*, 2. **PASS**.

Advance the right foot quickly, fifteen inches in front of the left, keeping right toe squarely to the right; advance the left foot to its relative position in front.

162. 1. *Rear*, 2. **PASS**.

Carry the left foot quickly fifteen inches to the rear of the right; place the right foot in its relative position in rear, keeping right toe squarely to the right.

163. 1. *Right*, 2. **VOLT**.

Face to the right, turning on the ball of the left foot, at the same time carry the right foot quickly to its position in rear.

164. 1. *Left*, 2. **VOLT**.

Face to the left, turning on the ball of the left foot, at the same time carry the right foot quickly to its position in rear.

Right rear and left rear volts are similarly executed facing about on the ball of the left foot.

The foregoing movements are first executed without arms.

PARRIES.

165. 1. *Right* (or *left*), 2. **PARRY**.

Move the point of the bayonet about six inches to the right.



Pl. 22, Par. 165.



Pl. 23, Par. 166.



Pl. 24, Par. 167.

GUARD.

Bring the piece back to the position of guard.

In the preliminary drill, after the parries and points, the position of guard is resumed, by command, after each movement.

When the men have become proficient the instructor will cause them to resume the guard without command.

166. 1. *Right low*, 2. **PARRY.**

Move the point of the bayonet quickly opposite the left shoulder; describe a semi circle from left to right, bring the point of the bayonet to the height of and in front of the right knee, barrel to the left, butt under right forearm, elbow two or three inches higher than the right shoulder.

167. 1. *Left low*, 2. **PARRY.**

Lower the point of the bayonet and describe a semi-

circle by carrying the piece to the left, covering the left side of the body, barrel down, left forearm behind the piece, point of the bayonet at the height of and to the left of the left knee, right forearm above the line of the eyes, hand well to the left.

168. 1. *Head*, 2. *PARRY*.



Pl. 25, Par. 168.

Raise the piece with both hands about eight inches in front of and four inches above the head, barrel downward and supported between thumb and forefinger of left hand midway between upper and lower bands.

169. In the different parries the piece should be lowered, raised or inclined to the right or left so as to cover the point attacked; the thrusts and lunges should be executed on the same principles, taking timely advantage of an adversary's failure to cover himself from attack.

When a lunge is made at a foot soldier, the point of the bayonet is directed at his breast. In the case of a horseman, it is directed against his side or against the head or flank of his horse. The foot soldier should endeavor to gain the horseman's left side, as the latter cannot use his arms on that side to advantage.

POINTS.

170. THRUST.

Thrust the piece quickly forward to the full length of the left arm, slipping it through the left hand to the guard; give it a rotary motion so as to bring the bar-

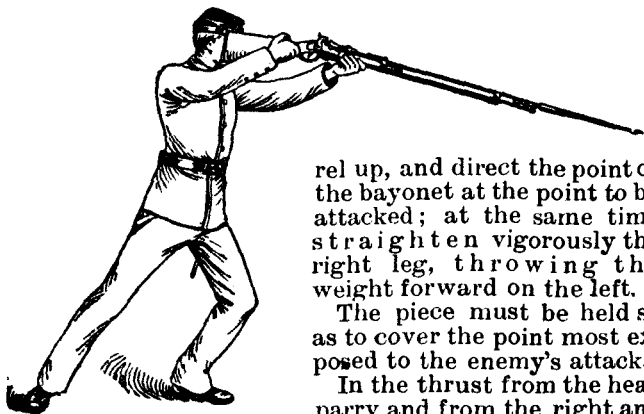

Pl. 26, Par. 170.

rel up, and direct the point of the bayonet at the point to be attacked; at the same time straighten vigorously the right leg, throwing the weight forward on the left.

The piece must be held so as to cover the point most exposed to the enemy's attack.

In the thrust from the head parry and from the right and left low parries the piece is not rotated.

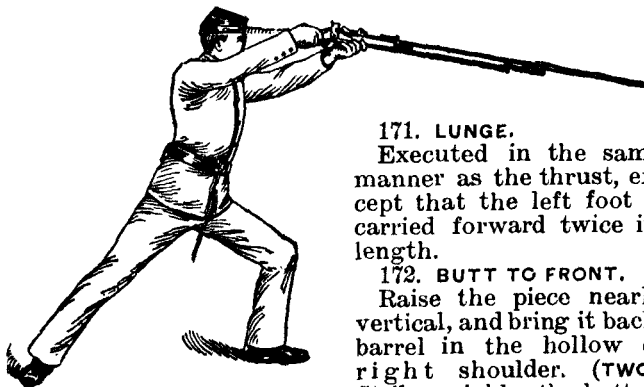

Pl. 27, Par. 171.

171. LUNGE.

Executed in the same manner as the thrust, except that the left foot is carried forward twice its length.

172. BUTT TO FRONT.

Raise the piece nearly vertical, and bring it back, barrel in the hollow of right shoulder. (TWO.) Strike quickly, the butt to

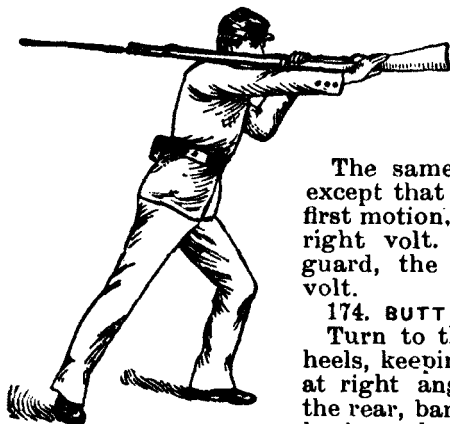

Pl. 28, Par. 172.

the front, straight-
en right leg, barrel
resting on right
shoulder.

**173. BUTT TO
RIGHT (OR LEFT).**

The same as butt to front,
except that in executing the
first motion, the men make a
right volt. In resuming the
guard, the men make a left
volt.

174. BUTT TO REAR.

Turn to the right on both
heels, keeping the feet nearly
at right angles, right toe to
the rear, barrel downward and
horizontal, right hand oppo-
site the neck, left hand near

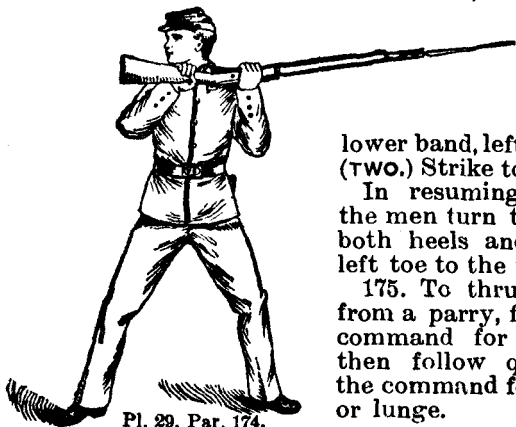

Pl. 29, Par. 174.

lower band, left leg straight.
(two.) Strike to the rear.

In resuming the guard,
the men turn to the left on
both heels and bring the
left toe to the front.

175. To thrust or lunge
from a parry, first give the
command for the parry,
then follow quickly with
the command for the thrust
or lunge.

Examples.

1. *Right*, 2. PARRY, 3. LUNGE, 4. GUARD

1. *Head*, 2. PARRY, 3. THRUST, 4. GUARD.

176. The execution of a parry and a thrust or a lunge may be determined by one command of execution.

Example.

1. *Head*, 2. PARRY and THRUST, 3. GUARD.

At the second command execute the parry, then thrust quickly; resume the guard at the third command.

177. When the soldier is thoroughly familiar with the different steps, parries and points, the instructor combines several of them by giving the commands in quick succession, increasing the rapidity and number of movements in combination as the men acquire skill.

Examples.

1. ADVANCE, HEAD PARRY AND LUNGE.

1. RETIRE, LEFT PARRY AND THRUST.

1. FRONT PASS, RIGHT PARRY AND THRUST; LEFT VOLT, HEAD PARRY AND THRUST.

Execute each in the order named, and resume the guard without command.

178. Every movement to the front should be followed by an attack (thrust or lunge); every movement to the rear by a parry and a thrust, as indicated in the foregoing example.

SCHOOL OF THE COMPANY.

179. The company is grouped into squads, under the leadership and immediate control of the non-commissioned officers, who are held responsible for discipline and order, in camp and quarters, and are trained as leaders of groups for battle.

180. The four or squad consists of four files, a corporal and seven privates; the corporal is the squad leader.

181. The term *four* is used in the commands and explanations of the close order drill; the term *squad* in the extended order drill.

182. Two or three squads form a section under a sergeant as chief of section; the section is used in the extended order drills; it is not a subdivision for movements in close order.

183. The company is divided into two platoons, each platoon into two sections.

Experienced privates are assigned as leaders of such squads as have no corporals. The squad leader is covered in the rear rank by a reliable man who acts as leader in his absence.

If any man of the front rank be absent he is replaced by his rear rank man.

If the company consists of an odd number of fours, the right platoon will be the stronger; if less than four sets of fours are present, the division into platoons is omitted; if a platoon consists of an odd number of fours, the right section will be the stronger; if a platoon consists of less than four sets of fours, the division into sections is omitted.

The platoons and sections are numbered from right to left, when in line, and from head to rear when in column; these designations change when, by facing

about, the right becomes the left of the line, or the head becomes the rear of the column.

The squads are designated as *right*, *left* or *center squad* of *first* (or such) *section*.

Posts of Officers, Non-Commissioned Officers and Field Music.

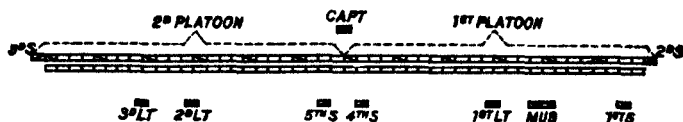

184. The captain is two paces in front of the center of the company.

The first lieutenant is chief of the first platoon and is two paces in rear of its center.

The second lieutenant is chief of the second platoon and is two paces in rear of its center.

When there is a third lieutenant he is posted on the left of the second lieutenant.

The first sergeant is two paces in rear of second file from the right of the first platoon; he is not attached to a section.

The second sergeant is in the front rank on the right of the first platoon; he is right guide of this platoon and also of the company, and chief of the first section.

The third sergeant is in the front rank, on the left of the second platoon; he is left guide of this platoon and also of the company, and is chief of the fourth section.

The fourth sergeant is two paces in rear of the second file from the left of the first platoon; he is left guide of the first platoon, and chief of the second section.

The fifth sergeant is two paces in rear of the second file from the right of the second platoon; he is right guide of the second platoon, and chief of the third section.

The field music, when not united in the battalion, is

in the line of file closers, on the right of the first lieutenant and conforms to the movements of the file closers. On the march, when required to play, it marches at the head of the column.

Absent officers and non-commissioned officers are generally replaced by the next in rank or grade.

Instruction of Officers and Non-Commissioned Officers.

185. The captain is responsible for the theoretical and practical instruction of his officers and non-commissioned officers. He requires them to study and recite these regulations so that they can explain thoroughly every movement before it is put into execution.

To Size the Company.

186. The men fall in in a single rank; the first sergeant faces them to the right and arranges them according to height, tallest man in front; the corporals place themselves according to height, the tallest as the seventh man, the others as every eighth man in rear. The sergeant commands: 1. *In two ranks form company*, 2. **MARCH.**

At the command *march*, the man in front faces to the left, the second man places himself in the rear rank covering the man in front; the remaining men close and form alternately in the front and rear rank, each facing to the front upon arriving in his place.

The sergeant then commands: 1. *Count*, 2. **FOURS.**

Beginning on the right the men of each rank count *one, two, three, four*, and so on to the left. The sergeants do not count.

If the four on the left consist of less than four men, they are assigned to other fours and placed in the line of file closers, each in rear of the four to which assigned; if the left four consists of more than three and less than six men, the number is increased to six or seven by taking the required number of men from a like number

of fours, at the rate of one from each, number three or numbers two and three being blank files.

The company is then divided into platoons and sections; the sergeants take their posts.

The company being sized, the fours habitually form in the same order.

To Form the Company.

187. In all formations under arms the men fall in at the order with bayonets unfixed.

Whenever a company falls in without arms, the men form as when under arms.

At the sounding of the assembly, the first sergeant takes his position in front of where the center of the company is to be, and facing it, makes the signal for assembly, or commands : **FALL IN.**

The second sergeant places himself facing to the front, where the right of the company is to rest, and at such a point that the center of the company will be six paces from and opposite the first sergeant; the fours form in their proper places on the left of the second sergeant, superintended by the other sergeants, who then take their posts. Fours of less than six men should be increased or broken up as provided for the left four (Par. 186).

The first sergeant brings the company to the right shoulder and calls the roll; each man answers "Here" and comes to the order as his name is called; the first sergeant then faces about, salutes the captain, reports the result of the roll call, and without command takes his post, passing around the right flank.

The lieutenants take their posts and draw sword as soon as the first sergeant has reported.

This formation will be used in the field and as far as practicable in camp and garrison.

188. When the company becomes reduced in number and the fours broken up, the men fall in without regard

to fours, but in their relative order, closing to the right so as to leave no blank files, the corporals placing themselves as number four, front rank. The sergeants superintend the formation and take their posts; the first sergeant calls the roll, has the company count fours, forms the left four according to Par. 186, and, if the company be large enough, he divides it into platoons and sections; he then reports and takes his post as explained.

Alignments.

189. The alignments are executed as prescribed in the School of the Soldier.

At each alignment the captain steps back two paces in prolongation of the line before giving his commands. This rule applies also to chiefs of subdivisions in column, in company and battalion drill.

At the command *front*, guides take their posts if not already there. This applies also to guides of platoons in company drill, and, in battalion, to guides of subdivisions in column.

To Open Ranks.

190. Being at a halt, at the carry or order: 1. *Open ranks*, 2. MARCH, 3. FRONT.

At the first command, the right and left guides step three paces to the rear to mark the new alignment of the rear rank; the first and second lieutenants place themselves on the right and left of the front rank; the third lieutenant covers the second, in the rear rank; the other file-closers step back three paces in rear of the line of the guides; the captain goes to the right flank, and sees that the guides are on a line parallel to the front rank; then places himself facing to the left, three paces in front of the right of the company and commands: MARCH. At this command the lieutenants take post three paces in front of the company, opposite their posts in line. Should a non-commissioned officer be chief of platoon, he remains in the line of file-closers

opposite the center of his platoon; the front rank dresses to the right; the rear rank men step backward, halt a little in rear of the line established by the guides, and then dress to the right on that line; the file-closers dress to the right.

The captain aligns the officers and the front rank; the right guide, the rear rank; the captain verifies the alignment of the rear rank and of the file-closers; the officers and file-closers cast their eyes to the front as soon as their alignment is verified.

At the command *front*, the men cast their eyes to the front, the guides resume their posts in the front rank, and the captain takes post facing to the front, three paces in front of the right guide.

To Close Ranks.

191. Being at a halt: 1. *Close ranks*, 2. **MARCH.**

At the command *march*, the lieutenants face about and resume their posts in line; the rear rank closes to facing distance, each man covering his file leader; the file-closers close to two paces from the rear rank; the captain takes his post.

192. The company executes the *halt, rests, facings, settings up, steps, marchings, turnings, manual of arms, and firings*, resumes *attention, kneels, lies down and rises*, as explained in the School of the Soldier, substituting in the commands, *company* for *squad*.

The same rule applies to platoons, detachments, details, etc., substituting their designation for *squad* in the commands.

While marching, the arms swing naturally, the hands moving about three inches in front and rear of the seam of the trousers.

In executing the *turn and halt*, the captain goes to the pivot flank of his company; the guide at the pivot halts or stands fast and resumes his place at the command *front*.

193. In the different firings, at the first command for loading or firing, the captain places himself three paces in rear of the file-closers, opposite the center of the company. After the command *cease firing*, the captain returns to his place in line.

Enlisted men in the line of file closers do not execute the loadings and firings.

Guides and enlisted men in the line of file closers execute the manual of arms during the drill unless specially excused, when they remain at the order. During ceremonies they execute all movements.

Guides in front marking the line stand at the order.

A non-commissioned officer as guide, or in command of a subdivision or detachment, carries his rifle as the men do.

These rules are general.

To Dismiss the Company.

194. Being in line at a halt, the captain directs the first sergeant: *Dismiss the company.* The officers fall out, the first sergeant salutes, steps in front of the company and commands: 1. *Port*, 2. **ARMS**, 3. **DISMISSED**.

Marching in Line to Effect a Slight Change of Direction.

195. The captain commands: *Incline to the right* (or *left*).

The guide advances gradually the left shoulder and marches in the new direction; all the files advance the left shoulder and conform to the movements of the guide, lengthening or shortening the step, according as the change is toward the side of the guide, or the side opposite.

Being in Line to March by the Flank.

196. 1. *Fours right* (or *left*), 2. **MARCH**.

The front rank of each four wheels ninety degrees to

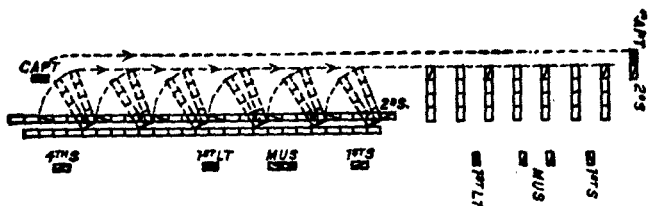

Pl. 31, Par. 196.

the right on a fixed pivot, the pivot man turning strictly in his place ; the man on the marching flank maintains the full step, moving on the arc of a circle with the pivot man as the center ; the men dress on the marching flank, shorten their steps according to their distance from it, and keep their intervals from the pivot.

The rear rank men cover their file leaders and conform to their movements. Upon the completion of the wheel, the front rank of each four takes the full step, marching in a direction parallel to the former front of the company ; the rear rank shortens the step until it gains the distance of forty-four inches ; the front rank of the second four is forty-four inches from the rear rank of the first four, and so on to the rear of the column ; the right and left guides place themselves forty-four inches in front and rear respectively of the left file of the leading and rear fours ; the file closers face to the right and maintain their relative positions.

197. The captain in column of fours, twos, and files is by the side of the leading guide on the flank opposite the file closers ; he takes this position at the command *march*.

The leading and rear guides in column of fours, twos, and files are in front and rear respectively of the leading or rear file on the side opposite the file closers.

The file closers march two paces from the flank of

the column and see that all the fours maintain accurately their distances.

In all changes by fours from line into column and column into line, or from column of fours to twos, files or the reverse, and in all wheels about by fours, either in line or column, the captain and guides take their proper places in the most convenient way as soon as practicable.

All wheels by fours, except in changing direction, are executed on a fixed pivot.

These rules are general.

Being in Line to Form Column of Fours and Halt.

198. 1. *Fours right (or left)*, 2. MARCH, 3. *Company*, 4. HALT.

The command *halt* is given as the front ranks complete the wheel; the rear ranks fall back to forty-four inches, and all dress toward the marching flank.

199. In column of fours, the ranks dress toward the side of the guide.

In all wheelings by fours, the forward march is taken upon the completion of the movement, unless the command *halt* be given.

These rules are general.

Marching in Column of Fours to Change Direction.

200. 1. *Column right (or left)*, 2. MARCH.

The leading rank of four wheels on a movable pivot, executed as prescribed in Par. 196, except that the pivot man takes steps of ten inches in quick time and twelve inches in double time, gaining ground forward so as to clear the wheeling point; the wheel completed, the leading rank takes the full step, the man on the side of the guide follows forty-four inches in rear of the guide, the other ranks move forward and wheel on the same ground. If the change of direction be toward the side of the guide, he shortens his step and wheels to

the right as if on the pivot flank of a rank of four; if the change be to the side opposite the guide, he wheels as if on the marching flank of a rank of four.

Column half right (or *half left*), is similarly executed, each rank of four wheeling forty-five degrees.

To Put the Column of Fours in March and Change Direction at the Same Time.

201. 1. *Forward*, 2. *Column right* (or *left*); or, 2. *Column half right* (or *half left*), 3. MARCH.

Being in Line to Form Column of Fours and Change Direction.

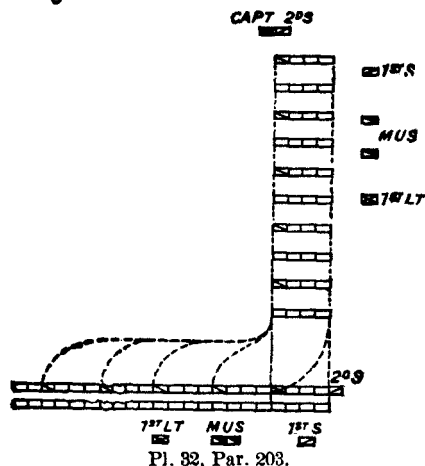

202. 1. *Fours right* (or *left*), 2. *Column right* (or *left*); or, 2. *Column half right* (or *half left*), 3. MARCH.

Execute *fours right* and then change direction. (Par. 200).

Being in Line, to March in Columns of Fours to the Front.

203. 1. *Right* (or *left*) *forward*, 2. *Fours right* (or *left*), 3. MARCH.

At the command *march*, the right guide places himself in front of the left file of the right four; the right four moves straight to the front, shortening the first three or four steps, the rear rank falls back to forty-four inches; the other fours wheel to the right each on a fixed pivot (Par. 196); the second four when its wheel is two-thirds completed, wheels to the left on a mov-

able pivot (Par. 200), and follows the first; the other fours, having wheeled to the right, move forward and each wheels to the left on a movable pivot, so as to follow the second.

Being in Column of Fours, to Change the File Closers from One Flank of the Column to the Other.

204. 1. *File closers on left (or right) flank*, 2. **MARCH.**

At the first command, the file closers close into the flank of the column, and at the command *march*, dart through the column. The captain and guides change to their proper positions.

To Oblique in Column of Fours, and to Resume the Direct March.

205. 1. *Right (or left) oblique*, 2. **MARCH.**

Each four obliques as prescribed for the squad (Par. 135).

The leading guide is the guide of the column when the oblique is toward his flank; when the oblique is toward the opposite flank the guide of the front rank of the leading four is the guide of the column.

To resume the direct march: 1. *Forward*, 2. **MARCH.**

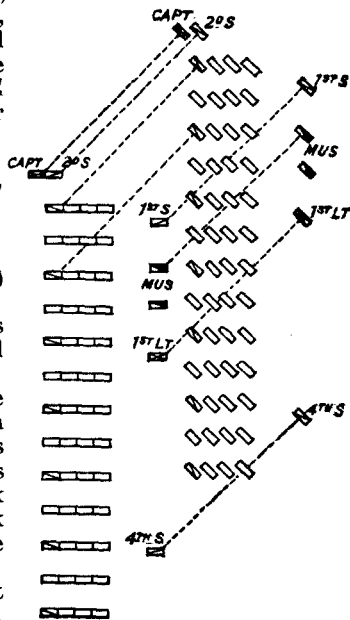

Pl. 33, Par. 205.

To March the Column of Fours to the Rear.

206. *Fours right (or left) about, 2. MARCH.*

Each four wheels 180 degrees to the right (Par. 196).

The man on the marching flank of the rear rank of each four preserves his distance; the man on the pivot flank closes up to his file leader, covers him during the wheel, and on its completion falls back to his proper distance.

The file closers do not pass through the column, but gain the space to the right or left necessary to preserve their interval from the flank.

To Form Line from Column of Fours.

207. To the right or left: 1. *Fours right (or left), 2. MARCH, 3. Guide (right or left); or, 3. Company, 4. HALT.*

At the command *march*, the fours wheel to the right. The rear rank of each four closes to facing distance during the wheel, and, if in double time, takes the distance of 36 inches, should the line advance on the completion of the wheel.

The guide is announced, or the command *halt* is given, the instant the fours unite in line.

If the line be formed toward the side of the file closers, they close in to the flank of the column at the first command, and at the command *march* dart through the column, between the rear rank of one four and the front rank of the succeeding four.

208. On right or left: 1. *On right (or left) into line, 2. MARCH, 3. Company, 4. HALT, 5. FRONT.*

At the command *march*, the leading four wheels to the right on a movable pivot and moves forward, dressing to the right, the guide places himself on its right; each of the other fours marches a distance equal to its front, beyond the wheeling point of the four next preceding, wheels to the right and advances as explained for

the first four; the rear guide places himself on the left of the rear four after it halts. The rear rank of each four closes to facing distance as the front rank commences to wheel.

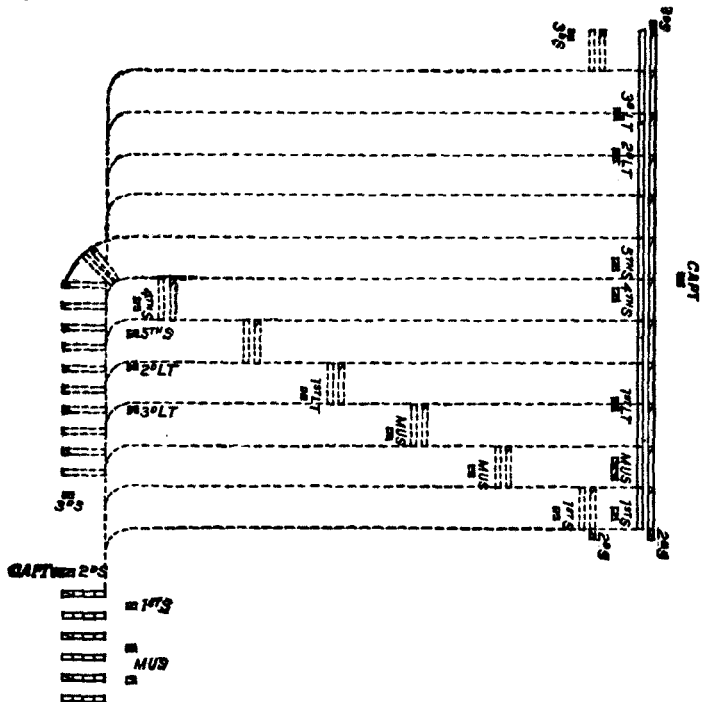

Pl. 34, Par. 208.

At the command *halt*, given when the leading four has advanced company distance in the new direction,

it halts and dresses to the right; the other fours successively halt and dress upon arriving in line.

The command *front* is given when the left four completes its dressing.

If the movement be executed toward the side opposite the file closers, each follows the four nearest him, passing in front of the following four.

209. In movements where it is prescribed that the leading four, or subdivision, moves company or subdivision distance to the front and then halts, it may be halted at a less distance when necessary. *This rule is general.*

210. To the front: 1. *Right* (or *left*) *front into line*, 2. **MARCH**, 3. *Company*, 4. **HALT**, 5. **FRONT**.

At the command *march*, the leading four moves straight to the front, dressing to the left; the guide in front places himself on its left; the other fours oblique to the right till opposite their places in line, when each marches to the front.

At the command *halt*, given when the leading four has advanced company distance, it halts and dresses to the left; the other fours halt and dress to the left upon arriving in line; the rear ranks close to facing distance upon halting; the guide in rear places himself on the right of the front rank upon the arrival of the last four in line; the command *front* is given when the last four completes its dressing.

If the movement be made toward the side of the file closers, they dart through the column as the oblique commences.

If marching in double time, or in quick time, and the command be *double time*, the captain commands, *Guide left*, immediately after the command *march*; the leading four moves to the front in quick time, its rear rank closing to facing distance; the other fours oblique in double time, each taking the quick time and dressing to the left upon arriving in line; the rear rank on arriving in line closes to facing distance.

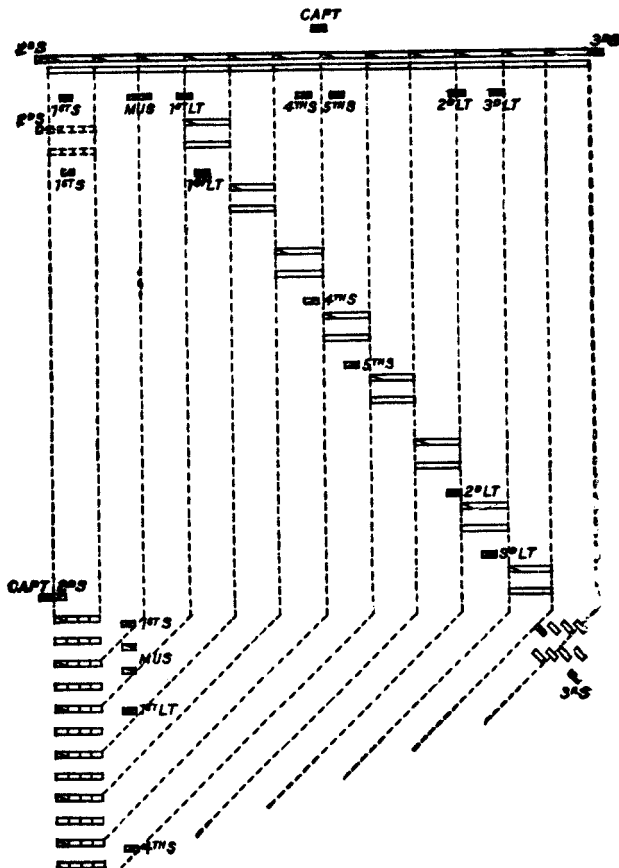

Pl. 35. Par. 210.

Being in Line, to Face to the Rear and to March to the Rear.

211. 1. *Fours right* (or *left*) *about*, 2. MARCH, 3. *Company*, 4. HALT ; or, 3. *Guide* (*right* or *left*).

The fours wheel about (Par. 206); the file closers dart through the nearest intervals.

212. The company at a halt, may be marched a few paces to the rear by the commands: 1. *Company*, 2. *About*, 3. FACE, 4. *Forward*, 5. *Guide* (*right* or *left*), 6. MARCH ; or, if in march, by the commands: 1. *To the rear*, 2. MARCH, 3. *Guide* (*right* or *left*).

The guides step into the rear rank now become the front rank; the file closers on facing about maintain their relative positions.

Obstacles.

213. Marching in line, to pass obstacles: 1. (So many) *fours from right* (or *left*) *to rear*, 2. MARCH.

At the command *march*, the designated fours execute *left forward*, *fours left*, on the four that remains in line next on their left.

The guide closes on the fours that remain in line.

The fours that have broken to the rear are formed in line at the commands: 1. *Rear fours right* (or *left*) *front into line*, 2. *Double time*, 3. MARCH.

The guide at the command *march*, hastens to the point where the flank of the company will be when the movement is completed.

Being in Column of Fours, to Form Column of Twos or Files.

214. This movement is always executed toward the file closers; it is used only for the purpose of reducing the front of the column to enable it to pass a defile or other narrow place, immediately after which the column of fours should be reformed.

1. *Right* (or *left*) *by twos*, 2. MARCH.

At the first command the rear rank of each four closes to facing distance.

At the command *march*, the two files on the right of each four move forward; the two files on the left mark time till disengaged, when they oblique to the right and follow the right files.

The distance between ranks in column of twos is facing distance; the guides take the same distance in front and rear of the column.

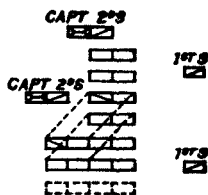

Pl. 36, Par. 214.

Being in Column of Fours at a Halt, to Form Column of Files.

215. *Right (or left) by file, 2. MARCH.*

At the first command the rear rank of each four closes to facing distance.

At the command *march*, the right file of the leading four moves forward, followed in succession by the files on its left; when the left file of the leading four is about to commence to oblique the right file of the second four moves to the front, and so on to the rear of the column, the men keeping closed as nearly as possible to facing distance; the guides take the same distance.

If marching, the leading file continues the march, the others halt without coming to the order, and resume the march at the proper time.

Column of files from column of twos is similarly executed.

216. A column of twos or files changes direction, is halted, and put in march by the same commands as a column of fours.

The march in column of twos or files is always in quick time.

217. A column of fours, twos, or files may be faced to the rear, or to a flank, and marched a short distance, but no other movements should be executed until the column is again faced to the original front. The officers and non-commissioned officers face with the column and retain their positions.

Being in Column of Twos or Files, to Form Column of Fours.

CAPT 2^{OS}



Pl. 37, Par. 218.

218. This movement is always executed away from the file closers.

Marching in column of twos: 1. *Form fours, 2. Left (or right) oblique, 3. MARCH.*

At the command *march*, the leading two of each four take the short step; the rear two oblique to the left until they uncover the leading two, when they move to the front; the fours having united, the rear ranks fall back to forty-four inches, and all

resume the full step.

Having Formed Column of Files from Column of Twos or Fours, to Form Column of Fours.

219. 1. *Form fours, 2. Left (or right) oblique, 3. MARCH.*

At the command *march*, the leading file of the first four halts, the rear rank man falling back to forty-four inches as soon as the file in rear has obliqued; the other files of the first four oblique to the left and place themselves successively on the left of the leading file, the rear rank taking the distance of forty-four inches from the front rank; the other fours successively form as explained for the first, the leading file of each halting at forty-four inches from the corresponding file of the four next in front.

Column of twos is formed from column of files on the same principles.

MOVEMENTS BY PLATOONS.

220. In movements by platoons each chief repeats such commands as are to be immediately executed by his platoon. Each chief gives the commands prescribed so as to insure the execution of movements by his platoon at the proper time.

In column whenever a subdivision is dressed its chief, after commanding *front*, places himself two paces in front of its center; in movements where the subdivisions are not dressed, he takes this position as soon as the column is formed.

These rules are general.

Being in Line, to Form Column of Platoons to the Right or Left.

221. 1. *Platoons right (or left)*, 2. MARCH.

Executed by each platoon. (Par. 140.)

At the first command, the chiefs of platoons caution : *Platoon right*; and at the command *march*, take their places two paces from the pivots of their platoons, verify the alignment, and command : *FRONT*.

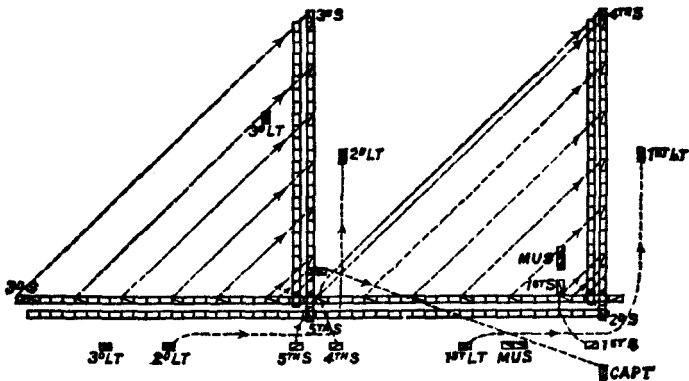

Pl. 38, Par. 221.

222. Whenever a company is formed in column of platoons or line of sergeants in columns of fours, the fourth and fifth sergeants place themselves as guides of

their platoons as soon as practicable; they return to their posts in the line of file closers when the company unites in line or column of fours, unless they mark an alignment.

223. The position of the captain in column of platoons is on the side of the guide, three paces from the flank of the column, abreast of the leading platoon.

224. The column of platoons is put in march, halted, obliques, and resumes the direct march by the same commands as the company in line.

Being in Line, to Form Column of Platoons, and Mov; Forward Without Halting.

225. 1. *Platoons*, 2. *Right* (or *left*) *turn*, 3. **MARCH**, 4. *Forward*, 5. **MARCH**, 6. *Guide* (*right* or *left*).

Executed by each platoon (Par. 141). The fifth command is given when both platoons have completed the turn.

226. The guide of the second platoon preserves the trace, step and a distance equal to the front of the platoon. *This rule is general.*

Being in Column of Platoons, to Change Direction.

227. Being in march: 1. *Column right* (or *left*), 2. **MARCH**.

At the first command, the chief of the first platoon commands: *Right turn*.

At the command *march*, the first platoon turns to the right (Par. 141), its chief adding: 1. *Forward*, 2. **MARCH**, on the completion of the turn.

The second platoon marches squarely up to the turning point and then changes direction by the same commands and means as the first.

Column half right (or *half left*) is similarly executed; each chief gives the preparatory command: *Right* (or *left*) *half turn*.

228. In changing direction in column of subdivisions, each chief, on the completion of the movement by his subdivision, announces the guide on the side it was previous to the turn. *This rule is general.*

To Put the Column of Platoons in March and Change Direction at the Same Time.

229. 1. *Forward*, 2. *Guide right (or left)*, 3. *Column right (or left)*; or, 3. *Column half right (or half left)*, 4. **MARCH.**

Being in Column of Platoons, to Face to the Rear and to March to the Rear.

230. 1. *Fours right (or left) about*, 2. **MARCH**, 3. *Company*, 4. **HALT**; or, 3. *Guide right (or left)*.

If one platoon be smaller than the other, the guide of the second platoon regains the trace and distance on the march.

To Form Line from Column of Platoons.

231. Before forming line to, or on the right or left, the captain requires the guide of the second platoon on the flank toward which the movement is to be executed to cover; if marching, he announces the guide on that flank, if not already there.

232. To the right or left: 1. *Platoons right (or left)*, 2. **MARCH**, 3. **FRONT.**

Executed by each platoon (Par. 140).

Each chief of platoon obliques to the left until he clears the marching flank, and takes his post.

The captain verifies the alignment and commands: **FRONT.**

233. To the right or left and continue the march: 1. *Platoons*, 2. *Right (or left) turn*, 3. **MARCH**, 4. *Guide (right or left)*, 5. *Forward*, 6. **MARCH.**

Executed by each platoon (Par. 141). The sixth command is given when both platoons have completed the turn.

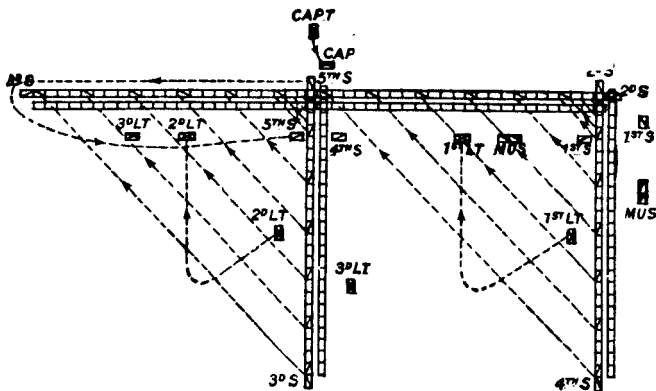

Pl. 39, Par. 232.

Each chief of platoon obliques to the left until he clears the marching flank, and takes his post.

234. On right or left : 1. *On right (or left) into line*, 2. MARCH, 3. FRONT.

The chief of the first platoon commands : *Right turn*. The first platoon turns to the right ; when the guide has advanced platoon distance, the platoon is halted by its chief, who passes around the right flank to his post.

The second platoon marches straight to the front ; its chief commands : 1. *Right turn*, 2. MARCH, when his platoon is opposite the right of its place in line ; the platoon turns to the right and when the right file has arrived on the line the platoon is halted by its chief, who passes around the left flank to his post.

The captain verifies the alignment and commands : FRONT.

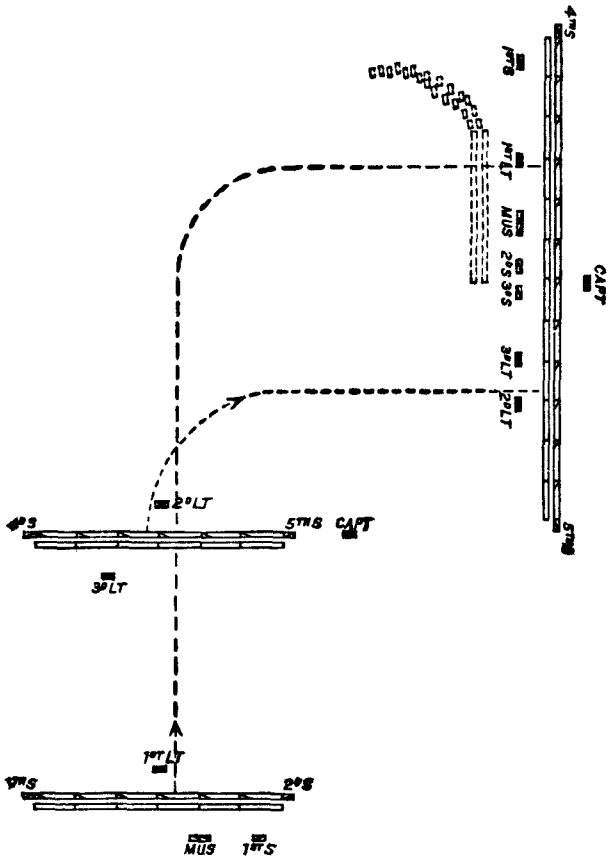

Pl. 40, Par. 234.

Being in Line, to Form Column of Platoons to the Front.

235. Being at a halt: 1. *Right (or left) by platoons*
2. MARCH, 3. *Guide left (or right).*

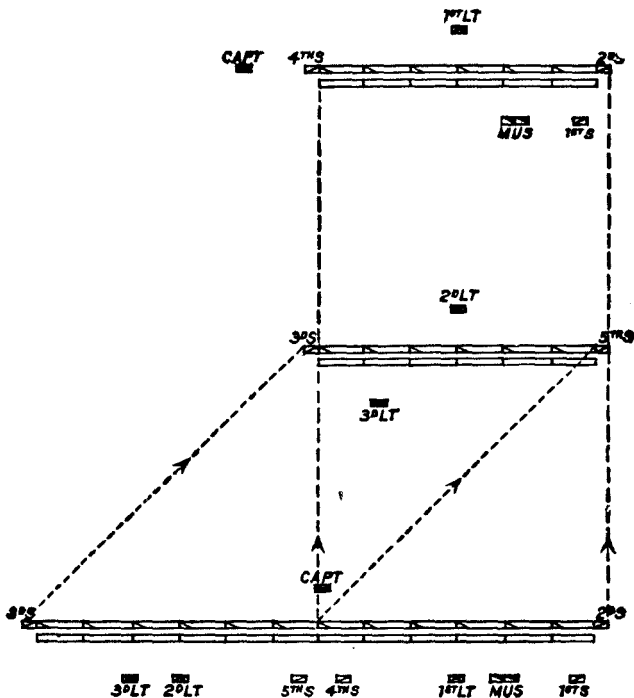

Pl. 41, Par. 235.

At the first command, the chiefs of platoons pass in double time to their places in front of their platoons

the chief of the right platoon commands : *Forward* ; the chief of the left : *Right oblique*.

At the command *march*, the right platoon moves forward. The chief of the left platoon commands : **MARCH**, when his platoon is disengaged ; the platoon obliques to the right, the chief commanding : 1. *Forward*, 2. **MARCH**, 3. *Guide left*, when the left guide arrives in the trace of the guide of the leading platoon.

If marching, the chief of the left platoon commands : 1. *Second platoon*, 2. *Mark time*, 3. **MARCH**, adding : 1. *Right oblique*, 2. **MARCH**, when his platoon is disengaged ; the movement is completed as from a halt.

Being in Column of Platoons, to Form Company to the Front.

236. Being at a halt : 1. *Form company*, 2. *Right (or left) oblique*, 3. **MARCH**, 4. **FRONT**.

At the second command, the chief of the first platoon commands : 1. *Forward*, 2. *Guide left* ; the chief of the second commands : *Right oblique*.

The first platoon advances platoon distance, when its chief commands : 1. *Platoon*, 2. **HALT**, 3. *Left*, 4. **DRESS**, and passes around the left flank to his post. The second platoon obliques to the right, its chief commanding : 1. *Forward*, 2. **MARCH**, 3. *Guide left*, when the platoon is opposite its place in line ; on arriving near the line, the chief halts the platoon, commands : 1. *Left*, 2. **DRESS**, and passes around the right flank to his post.

The captain superintends the alignment from the left flank.

If marching in quick time, the chief of the leading platoon commands : *Guide left*, and the movement is completed as just explained.

If marching in quick time and the command be *double time*, the captain commands : *Guide left (or right)* immediately after the command *march* ; the chief of the leading platoon cautions it to advance in quick time and

commands: *Guide left*; the chief of the second platoon commands: *Double time*, and when the platoon is abreast of the leading platoon commands: 1. *Quick time*, 2. **MARCH**; the platoons having united, the chiefs pass around the flanks to their posts.

If marching in double time, the chief of the first platoon, at the first command of the captain, commands: *Quick time*.

Being in Column of Platoons, to March by the Flank.

237. 1. *Fours right* (or *left*), 2. **MARCH**, 3. *Guide* (*right* or *left*).

The right and left guides of each platoon place themselves as in Par. 196, each chief of platoon on the left of his leading guide; the leading guide of the platoon on the flank announced is the guide of the company; the leading guide of the other platoon marches abreast of him and preserves the interval necessary to form front into line.

The position of the captain is on the side opposite the file closers, three paces from the flank and abreast of the chiefs of platoons.

Marching by the flank of platoons, the right platoon is the first, the left the second.

To March Again in Column of Platoons.

1. *Fours right* (or *left*), 2. **MARCH**, 3. *Guide* (*right* or *left*).

Being in Line, to Advance in Line of Platoons in Columns of Fours.

238. 1. *Platoons*, 2. *Right* (or *left*) *forward*, 3. *Fours right* (or *left*), 4. **MARCH**, *Guide* (*right* or *left*).

At the first command, the chiefs pass quickly around the flanks and place themselves in front of their platoons.

At the command *march*, each platoon executes the movement as prescribed for a company (Par. 203).

To form again in line: 1. *Platoons*, 2. *Right (or left) front into line*, 3. **MARCH**, 4. *Company*, 5. **HALT**, 6. **FRONT**.

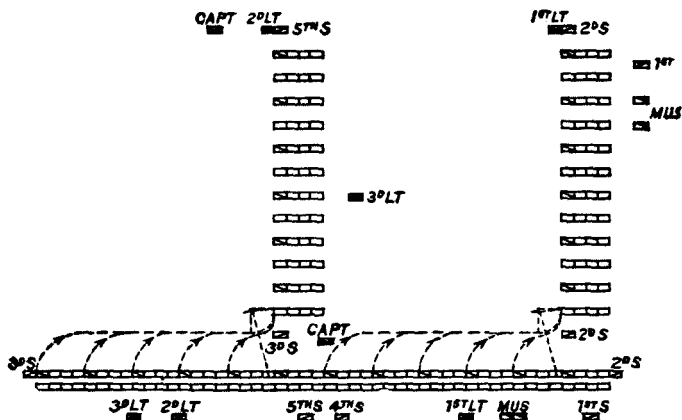

Pl. 42, Par. 238.

Each platoon forms front into line; the chiefs of platoons return to their posts by dropping to the rear or by passing around the heads of their platoons, according as the front into line is executed toward the side of the file closers or toward the side opposite.

The command *halt* is given when the leading fours have advanced platoon distance.

If the movement be executed in double time, the captain commands: *Guide left (or right)* after the command *march*.

Being in Column of Fours, to Form Front into Line of Platoons in Columns of Fours.

239. 1. *Right (or left) front into line of platoons in columns of fours*, 2. **MARCH**.

The first platoon is marched platoon distance to the front and halted; the second executes *column half right*, and having gained its interval (Par. 237), *column half left*, and is halted abreast of the first platoon.

Being in Column of Fours to Form on Right or Left into Line of Platoons in Columns of Fours.

240. 1. *On right (or left) into line of platoons in columns of fours*, 2. MARCH.

The first platoon executes *column right*, advances platoon distance and twelve paces in the new direction and is halted; the second is marched beyond the first and when opposite its place executes *column right* and is halted abreast of the first platoon.

Marching in Line of Platoons in Columns of Fours, to Form Column of Fours to the Right or Left.

241. 1. *Platoons*, 2. *Column right (or left)*, 3. MARCH.

The chiefs pass around the heads of their platoons as they are about to unite in column of fours.

Being in Column of Platoons, to Form Column of Fours.

242. 1. *Platoons*, 2. *Right (or left) forward*, 3. *Fours right (or left)*, 4. MARCH.

The chiefs pass around the heads of their platoons as they are about to unite in column of fours.

Being in Column of Fours, to Form Column of Platoons.

243. 1. *Platoons*, 2. *Right (or left) front into line*, 3. MARCH, 4. *Company*, 5. HALT.

At the second command, each chief places himself near the head of his platoon.

At the command *march*, each platoon executes *right front into line*. (Pars. 210 and 189.)

The command *halt* is given when the leading four has advanced platoon distance.

If marching in double time, or in quick time, and the command be *double time*, the captain commands: *Guide left* (or *right*) after the command *march*.

Marching in Column of Fours, to March in Line of Platoons in Columns of Fours to the Right or Left.

244. 1. *Platoons*, 2. *Column right* (or *left*), 3. *MARCH*, 4. *Guide* (*right* or *left*).

Each platoon changes direction to the right, and each chief takes his place by the side of his leading guide.

Route Step.

245. The column of fours is the habitual column of route. The rate is three to three and a half miles per hour.

Marching in quicktime: 1. *Route step*, 2. *MARCH*.

The men carry their pieces at will, keeping the muzzle elevated; they are not required to preserve silence nor keep the step. The ranks cover, and preserve their distance.

If from a halt: 1. *Forward*, 2. *Route step*, 3. *MARCH*.

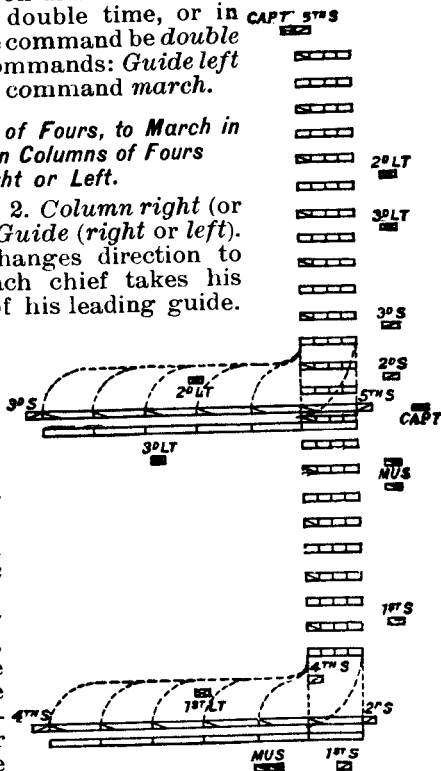

Pl. 43, Par. 242.

To resume the cadenced step: 1 *Company*, 2. **ATTENTION.**

At the command *attention*, the pieces are brought to the right shoulder and the cadenced step in quick time is resumed.

The company marching in line or in column of platoons may also march in the route step, the rear rank falling back to thirty-six inches.

The company in route step changes direction by the same commands as in the cadenced step.

Upon halting while marching in route step, the men come to the rest at the order.

246. To march at ease: 1. *At ease*, 2. **MARCH.**

The company marches as in the route step, except that silence is preserved.

The march at ease will be frequently used in the foregoing movements.

To resume the cadenced step: 1. *Company*, 2. **ATTENTION.**

If halted while marching at ease, the men remain at ease at the order.

At ease, either marching or at a halt, and at the rest, officers carry the sword at will; marching at route step, at will or in the scabbard.

247. The company having been formed, the right may become the left; the flanks the center, and the reverse.

Whenever the flanks become the center, the second and third sergeants take the posts in the line of file closers prescribed for the fifth and fourth sergeants, each with his own platoon; the fourth and fifth sergeants take the posts prescribed for the third and second sergeants. The first sergeant always remains with the original first platoon; when in line, in rear of the second file from the outer flank, taking the corresponding position when the platoons unite in column of fours.

248. The captain holds the file closers responsible for the fours near them and requires them to correct errors.

SCHOOL OF THE BATTALION.

249. In this school the senior officer present is the instructor; in the text he is designated as major.

250. Captains repeat such of the commands as are to be immediately executed by their companies; as, *forward, fours right, march, halt, etc.*; they do not repeat the major's commands in executing the manual, nor those commands which are not essential to the execution of a movement by their companies; as, *deploy column, etc.*

In any movement, each captain gives his command so as to insure its execution by his company at the proper time.

251. When the formation will admit of the simultaneous execution of movements by the companies, the major may have them execute movements in the School of the Company by prefixing, when necessary, the command: *Companies* (or *platoons*) to the commands therein prescribed; e. g., 1. *Companies*, 2. *Right forward*, 3. *Fours right*, 4. MARCH. 1. *Companies*, 2. *Right by platoons*, 3. MARCH. 1. *Companies*, 2. *Right front into line*, 3. MARCH, etc.

When line, line of columns, or column of subdivisions is formed, the major announces the guide, if the march is to be continued.

Instruction of Officers.

252. The major is responsible for the instruction of his battalion.

The officers are assembled for theoretical and practical instruction.

The instruction of officers embraces the Drill Regulations and such other instruction as pertains to their duties in peace and war.

Each captain should be required to drill the battalion.

Formation of the Battalion.

253. The battalion is composed of two or more companies, not exceeding six; the movements explained herein are on the basis of a battalion of four companies.

For drill and ceremonies the companies may be equalized by transferring the men from the larger to the smaller. The companies are arranged according to the rank of captains, the senior commanding the right company, the second in rank the left, and the third the center or right center.

The following table shows the order of companies in line from right to left.

				2	1
			2	3	1
		2	4	3	1
	2	5	3	4	1
2	5	6	3	4	1

Companies whose captains are absent are posted in line according to the relative rank of the officers present in command of them.

A company whose captain is absent for a few days only, or is in command of the battalion, retains its place according to his rank unless otherwise directed.

After the battalion is formed no cognizance is taken of the relative order of the companies.

In whatever direction the battalion faces, the companies are designated numerically from right to left in

line, and in line of columns, and from head to rear in column, *first company, second company, etc.*

In like manner the companies to the right of the center in line constitute the *right wing*; those to the left, the *left wing*; when the number of companies is uneven, the original right wing contains the odd company. The left company right wing and right company left wing are designated respectively *right* and *left center companies*.

When a new formation necessitates a change of designation the change takes effect upon the completion of the movement.

In designating their companies the captains use the letter designation : as *Company "A," etc.*

When a battalion is composed of fractions of several regiments, the companies of each regiment are arranged as already explained ; the fractions are then arranged in line from right to left, according to the rank of the senior officer present in each, the senior on the right.

Color Guard.

254. If the color be with the battalion, the original right center company is the color company ; the color guard remains with it unless otherwise directed ; it is posted as follows :

In line, the color bearer is between the guides of the right and left center companies ; the other members of the guard are in his rear, in the line of file closers. The color guard takes the same position relative to the color company when in column at full distance or in mass.

In column of fours, the color bearer is between the wings, abreast of the guide of the color company, in front or in rear of the file next the file closers ; the other members of the guard retain their places in the line of file closers. The color guard retains the same relative position, both in line and in column of fours, when marching with the color company only.

In forming line of columns the color guard remains with the flank of the company it was with before the movement commenced.

If by movements of the battalion the original left of the color company is changed so as not to be the center of the battalion, the color bearer and guard will take post between the wings, whether on the left or right of the color company, or at its head or rear in column of fours.

Posts of Field and Staff.

255. In line, the major is posted twenty paces in front of the center of the battalion; the adjutant and sergeant major are opposite the right and left of the battalion, six paces in rear of the file closers. The staff officers, except the adjutant, in the order of rank, the senior on the right, take post at one pace apart, six paces to the right and in line with the front rank of the battalion. The non-commissioned staff officers, except the sergeant major, take post similarly on the left of the front rank.

In column, the major is on the side of the guide, twenty paces from and opposite the center.

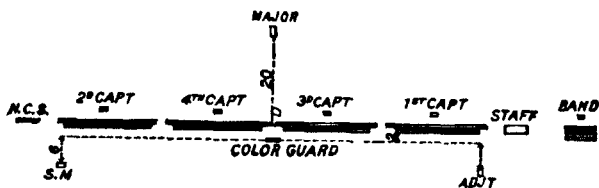

Pl. 44, Par. 255.

The adjutant and sergeant major are on the side of the guide, opposite and six paces from the head and rear of the column, each in his own wing. The other staff and non-commissioned staff officers take post, in

column of subdivisions, in their respective wings, on a line equal to the front of the column, in order of rank, senior on the right, six paces in front of the captain of the leading company or six paces in rear of the file closers of the rear company. In column of fours they take post similarly in front of the leading or in rear of the rear company. When the column faces to the rear the staff and non-commissioned staff officers face about individually and maintain their relative positions.

In line of columns, the major is twenty paces in front of the center; the adjutant and sergeant major are abreast of and six paces outside of the leading guides. The other staff and non-commissioned staff officers are in the same relative order as in line, one pace to the right and left, respectively, of the adjutant and sergeant major. If the line or line of columns face to the rear, the staff and non-commissioned staff officers face about individually and move up abreast of the front rank or leading guides, keeping their relative positions, except that in line the adjutant and sergeant major take the corresponding positions as when facing to the former front, each in his own wing.

The field and staff officers are mounted.

In making the about, an officer, mounted, habitually turns to the left about.

Post of the Band and Field Music.

256. The band is posted with the left of its front rank, twenty-four paces to the right of the front rank of the battalion.

In column, it marches with its rear rank twenty-four paces in front of the leading company, or its front rank twenty-four paces in rear of the rear company, according as the battalion is facing. In line of columns, the band retains its line position, marching abreast of the leading guides.

To Form the Battalion.

257. The companies having been formed on their parade grounds, *adjutant's call* is sounded, at which the adjutant proceeds to the point where the base company is to form; the sergeant major reports to him and is posted on the line facing the adjutant at nearly company distance; the adjutant and sergeant major then draw swords.

The right center or center company is the first established, and is conducted by its captain so as to arrive from the rear, parallel to the line; the right and left guides of the company precede it on the line by about twenty paces, taking post facing each other, at order arms, under the direction of the adjutant and sergeant major.

The line is prolonged in the right wing by the right and left guides, who precede their companies on the line by about twenty paces and establish themselves facing the guides first posted, at a little less than company distance apart, the one nearest the guide of the preceding company being about five paces in his rear; the adjutant assures the position of the guides, placing himself in rear of the right guides as they successively arrive. The line is similarly prolonged in the left wing by the company guides, the sergeant major assuring them in their positions, placing himself in rear of the left guides.

When the right center company arrives near the line the captain halts it, places himself facing to the front near the left guide, and dresses the company to the left; the breasts of the men opposite the right and left guides rest respectively against their left and right arms; the companies of the right wing successively form from left to right with an interval of three paces between guides when in line, each company being halted near the line and dressed to the left, as explained for the center company; the companies of the left wing form successively from right to left and are dressed to the right.

258. Captains, when dressing their companies in line

place themselves on the line, on the flank toward which they dress, facing to the front.

Each captain after dressing his company, commands : **FRONT**, and takes his post.

These rules are general.

259. At all formations of the battalion a non-commissioned officer in command of his company takes his post on the right of the right guide, at the command *guides posts*, and, except in formations for ceremonies, when the major commands *carry arms* after receiving the report of the adjutant, he takes the post prescribed for the captain.

260. Before sounding the *adjutant's call* the band takes a position designated by the adjutant, and marches at the same time as the companies to take its position in line.

The major takes post facing the line, at a distance in front of the center of the battalion about equal to half its front.

The adjutant, having assured the position of the guides of the right company, places himself two paces to the front, facing to the left, and when the last company arriving on the line is dressed, commands : 1. *Guides*, 2. **POSTS**.

At the command *guides posts*, the sergeant major and guides take their posts in line, and the staff and non-commissioned staff draw sword and take their posts.

The adjutant moves at a trot or gallop (if dismounted, in quick time) by the shortest line to a point midway between the major and the center of the battalion, faces the latter and halts; then brings the battalion to the carry and present, faces about, salutes the major, and reports : *Sir, the battalion is formed.*

The major returns the salute with the right hand, directs the adjutant, *Take your post, sir*; draws sword, and brings the battalion to the order or carry.

The adjutant faces about and returns around the right of the battalion to his post.

261. The battalion may be formed in line on the right or left company on the same principles, the guides being posted as in the left or right wing.

The battalion may also be assembled in column of fours.

In both cases the companies are arranged in the same relative order as when the formation is on the center company. When assembled in column the adjutant reports to the major as soon as the last company has taken its place.

Equalizing the Battalion.

262. The companies are usually equalized by transfers before the battalion is formed, but when this is not done the major may form column of companies and direct the adjutant, first, to equalize the companies by transferring men from the larger to the smaller companies; second, to break up one company and equalize by transferring the men to other companies; third, to form an additional company and equalize by taking men from the other companies; also, to make the necessary assignment of officers and guides.

To Open Ranks.

263. Being at a halt: 1. *Open ranks*, 2. MARCH, 3. FRONT.

At the first command the major goes to the right of the battalion. The adjutant places himself facing to the left three paces in rear of the front rank, opposite the right of the battalion. The right guides of each company and the guide on the left of the battalion place themselves three paces in rear of the front rank, opposite their places in line, in order to mark the new alignment of the rear rank; they are aligned by the adjutant on the left guide of the battalion.

The lieutenants and the other file closers take post as in open ranks in the company (Par. 190).

At the command *march*, the company and staff officers place themselves opposite their posts in line, three paces in advance of the front rank, dress to the right and cast their eyes to the front as soon as their alignment is verified. The front rank dresses to the right; the men in the rear rank step back a little in rear of the line traced for this rank, halt, and dress forward on the right guides, who verify the alignment of the men in their respective companies.

The adjutant verifies the alignment of the file closers on the left file closer, who posts himself accurately three paces in rear of the line of guides.

The color bearer remains in his place; the other members of the color guard step back with the file closers.

The sergeant major takes post one pace to the left of and in line with the front rank.

The major verifies the alignment of the officers and the ranks.

The band takes three paces between ranks, the alignment being verified by the drum major.

At the command *front*, given when the ranks are aligned, the adjutant takes post three paces to the right of the battalion, in line with the company officers; the guides and drum major return to their places in line; and the major takes post facing to the front, twenty paces in front of the center of the battalion.

Should the battalion have wheeled about by fours, the sergeant major performs the duties of adjutant.

To Close Ranks.

264. 1. *Close ranks*, 2. MARCH.

At the command *march*, all the officers face about, and return to their places in line; the rear rank closes to facing distance from the front rank; the file closers and the two members of the color guard close to two paces from the rear rank, and the band closes its ranks.

Manual of Arms.

265. The manual of arms is executed in the battalion with closed or open ranks.

The color guard do not execute the loadings and firings; in rendering honors they execute all the movements in the manual, and on drill, except when specially excused.

In the loadings and firings, the post of the major is twenty paces in rear of the center of the battalion.

266. At the first command for loading or firing the captains take place as prescribed (Par. 193). After firing ceases the major commands: **POSTS**, the captains return to their posts in line.

These rules are general.

To Fire by Company.

267. The major designates the objective and commands: 1. *Fire by company*, 2. *One (two or three) volley*, 3. **COMMENCE FIRING**.

At the third command, the captains of the odd-numbered companies command: 1. (Such) *company*, 2. *At* (such an object), 3. *At* (so many) *yards*, 4. *Company*, 5. **READY**, 6. **AIM**, 7. **FIRE**, 8. **LOAD**.

When the captain of each even-numbered company sees the pieces in the company on his right in the position of load, he gives the same commands. The captains of the odd-numbered companies conform to the same rule with regard to the even-numbered companies on their left.

268. The fire by battalion and the fire at will are executed by the same commands and means as in the squad, substituting in the commands *battalion* for *squad* (Pars. 144 to 150).

269. The rests, resuming attention, stacking and taking arms, are executed as prescribed for the company, substituting in the commands *battalion* for *company*.

To Dismiss the Battalion.

270. *Dismiss your companies.*

Each captain conducts his company to its parade ground, where it is dismissed as prescribed.

To March in Line.

271. Being at a halt ; 1. *Forward*, 2. *Guide center*, 3. **MARCH.**

The left guide of the right center company is the center guide and regulates the step and direction, the guides maintaining the interval of three paces between companies ; the captains in front of the center of their companies see that they preserve a general alignment without abruptly shortening or lengthening the step ; the major superintends the march of the battalion.

272. At the command *guide center*, captains caution : *Guide left* (or *right*), according as they are in the right or left wing. *This rule is general.*

273. To make a slight change of direction, the major commands : *Incline to the right* (or *left*), and indicates the new line of direction. The guide gradually advances his left shoulder, giving time for the alignment to conform to his movement.

274. If the battalion loses step, the major commands : **STEP** ; captains and their companies immediately take the proper step.

275. Marching considerable distances, the line formation that the battalion habitually takes is the line of columns of fours.

To Face the Battalion to the Rear, and to March it to the Rear.

276. Being in line : 1. *Fours right* (or *left*) *about*, 2. **MARCH**, 3. *Battalion*, 4. **HALT** ; or, 3. *Guide center*.

The battalion wheels about by fours (Par. 211) ; the color bearer turns about and takes his place in the

front rank; the other members of the color guard dart through to their places in the line of file closers; the command *halt* is given as the fours unite in line.

In wheeling by fours, if the pivots cover and the fours wheel properly, no dressing is needed; the major will direct a captain to dress his company when necessary.

If the battalion be not halted, the major commands: *Guide center* as the fours unite in line.

Whenever a battalion in line wheels about by fours, the adjutant and sergeant major pass around the flanks. The battalion is drilled by the same commands as when facing in the opposite direction.

277. The battalion may be marched a few paces to the rear by the commands: 1. *Battalion*, 2. *About*, 3. **FACE**, 4. *Forward*, 5. *Guide center*, 6. **MARCH**; or, if in march, by the commands; 1. *To the rear*, 2. **MARCH**, 3. *Guide center*. The officers, sergeant major, and file closers, upon facing about, remain in their relative positions; the guides step into the rear, now become the front rank, until the battalion is again faced to the front.

To Oblique in Line.

278. 1. *Right (or left) oblique*, 2. **MARCH**

The major sees that the battalion continues parallel to its original line.

To resume the direct march: 1. *Forward*, 2. **MARCH**.

Alignments.

279. Being at a halt, to rectify the alignment: *Captains rectify the alignment*.

The captains in the right wing dress their companies successively to the left, each as soon as the captain next on his left commands *front*; the captains in the left wing dress their companies similarly to the right. The center companies are dressed first without waiting for each other.

280. To give the battalion a general alignment: 1. *Guides* (such) *company on the line*, 2. *Guides on the line*, 3. *On the center (right or left)*, 4. DRESS, 5. *Guides*, 6. POSTS.

At the first command the designated guides place themselves on the line facing the major, who establishes them in the direction he wishes to give the battalion.

At the second command the guides of the other companies are posted as in forming the battalion (Par. 257).

At the command *dress* the base company, if an interior company, dresses to the left or right according as it is in the right or left wing; if on a flank, toward its outer flank; the others toward the base company.

If the new line be oblique to or at considerable distance from the battalion, the captains conduct their companies so as to arrive parallel to the line, halt, and dress them as explained.

At the command *posts* the guides return to their posts.

If the new direction of the line be such that one or more companies find themselves in advance of it, the major, before establishing the guides, causes such companies to be moved to the rear.

To Pass Obstacles.

281. When marching in line or in column, captains will, without the command of the major, so conduct their companies as to pass obstacles with the greatest facility, and then resume the original formation.

Being in Line, to March by the Flank.

282. 1. *Fours right (or left)*, 2. MARCH.

The adjutant and sergeant major pass around the flanks to their posts in column.

In column of fours the leading guide of each company, except the first, marches in the trace of the rear guide of the preceding company and maintains the distance of seventy-two inches from him.

283. A battalion at a halt may be marched a short distance to the right or left in column of files by the commands: 1. *Right (or left)*, 2. **FACE**, 3. *Forward*, 4. **MARCH**.

If the battalion be in march: 1. *By the right (or left) flank*, 2. **MARCH**.

All face individually, and maintain their relative positions.

To halt the battalion and face it to the front: 1. *Battalion*, 2. **HALT**, 3. *left (or right)*, 4. **FACE**.

To resume the march in line: 1. *By the left (or right) flank*, 2. **MARCH**, 3. *Guide center*.

To Break into Column of Fours from the Right or Left, to March to the Left or Right.

284. Being in line at a halt: 1. *Column of fours*, 2. *Break from the right (or left) to march to the left (or right)*, 3. **MARCH**.

The captain of the right company commands: 1. *Right forward*, 2. *Fours right*.

The company moves in column of fours to the front; the captain commands: 1. *Column left*, 2. **MARCH**, when the leading four has advanced company distance; the guide then directs his march parallel to the front of the battalion. Each of the other companies executes the same movements in time to follow at proper distance in rear of the preceding company.

285. Being in column of fours, at the commands: 1. *File closers on the left (or right) flank*, 2. **MARCH**, the captains, guides, adjutant, sergeant major, and file closers change to the opposite flank.

286. The battalion being in column of fours, *halts, advances, obliques, changes direction, marches by the flank and to the rear, forms column of twos and files, and reforms in column of twos and fours*, the same as a company, substituting in the commands *battalion* for *company*.

Being in Column of Fours, to Form Line to the Right or Left.

287. 1. *Fours right (or left)*, 2. MARCH, 3. *Battalion*,
4. HALT.

The command *halt* is given as the fours unite in line.

- If the battalion be not halted, the major commands:
3. *Guide center*, as the fours unite in line.

General Rules for Successive Formations.

288. Successive formations include formations, either into line or column, in which the several subdivisions arrive in their places successively.

(a) In all successive formations into line, except formations by two movements, the adjutant or sergeant major at the head of the column or nearest the point of rest posts on the line opposite its right and left files, the two guides of the company first to arrive. The guides face toward the point of rest; if the formation be central, they are posted on the line, in front of the leading company, facing each other.

(b) In all formations from a halt, the guides are posted at the preparatory command indicating the direction in which the line is to extend; if marching, they hasten toward the point of rest at the preparatory command, and are posted at the command MARCH.

(c) In the formations on right (or left) into line, the first guide is posted company distance to the right (or left) of the head of the column.

(d) In the formations front into line, the guides are posted company distance in front of the head of the column.

(e) In the deployments, they are posted against the leading company, in front of the head of the column.

(f) In changes of front, the first guide is posted company distance to the right of the first or left of the fourth company, according as the change of front is to the right or left.

(g) In any formation where it is prescribed that the guides are to be posted company distance from the column or line, they may be posted at a less distance when necessary.

(h) The line is prolonged as in forming the battalion; the guides are assured by the adjutant or sergeant major nearest the point of rest, or by both, if the formation be central; the companies are halted near the line and dressed up to the guides toward the point of rest.

(i) When the line is to be formed facing to the rear, the guides are so posted as to permit the leading company to pass between them, after which the second guide closes to a little less than company distance from the first. The guides of the other companies follow the same rule.

(k) When the principles of successive formations are well understood the guides may be required to post themselves.

(l) The major commands: 1. *Guides*, 2. **POSTS**, at the completion of all successive formations into line.

(m) In successive formations, should the major desire to commence firing, pending the completion of the movement, he instructs the captains as to the kind of fire; the adjutant or sergeant major at the head of the column cautions the guides not to take post marking the line.

Being in Column of Fours, to Form on Right or Left, into Line

289. Being at a halt: 1. *On right (or left) into line*, 2. **MARCH**.

The captains of companies in rear of the first command: *Forward*.

The first company executes *on right into line* (Par. 208).

Each of the other captains commands: 1. *On right into line*, 2. **MARCH**, when his leading four is nearly opposite its place in line.

If marching, the captains of companies in rear of the first omit the command *forward*.

Being in Column of Fours, to Form Front into Line.

290. Being at a halt: 1. *Right (or left) front into line*,
2. MARCH.

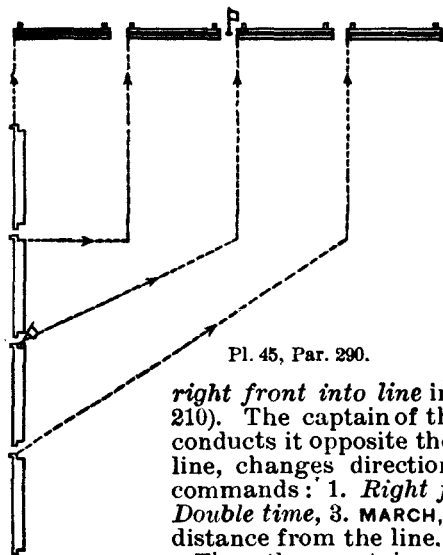

Pl. 45, Par. 290.

At the first command the captain of the first company commands: 1. *Right front into line*, 2. *Double time*; the captain of the second company commands: 1. *Forward*, 2. *Column right*; the other captains: 1. *Forward*, 2. *Column half right*.

The first company executes *right front into line* in double time (Par. 210). The captain of the second company conducts it opposite the left of its place in line, changes direction to the left, and commands: 1. *Right front into line*, 2. *Double time*, 3. MARCH, when at company distance from the line.

The other captains conduct their companies to a point at twice company distance in rear of the left of their places in line, change direction half left, and when at company distance from the line conform to what is explained for the captain of the second company.

If marching, the captains of companies in rear of the first omit the command *forward*.

Front into line may be executed in a direction oblique to that of the column by first causing the leading company to execute a partial change of direction. The line is formed at right angles to the new direction of the leading company. The other companies are, if possible, so conducted as to arrive opposite their places, at twice company distance in rear of the line.

To Form Front into Line Faced to the Rear.

291. 1. *Right (or left) front into line faced to the rear.*
2. MARCH.

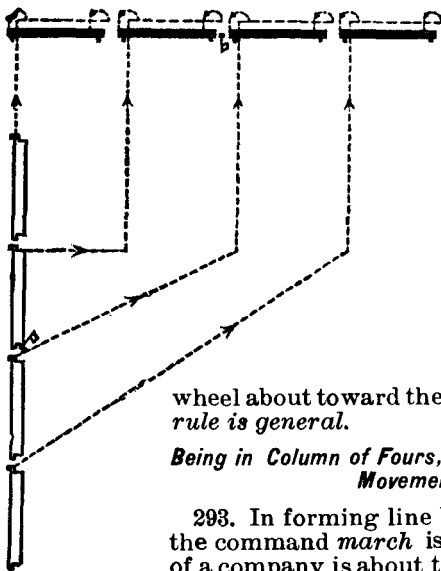

Executed as explained, except that each captain halts his company just beyond the line; all the fours having arrived in line, the captain wheels his company to the left about by fours, halts it, and dresses it to the right.

292. In forming line faced to the rear the fours wheel about toward the point of rest. *This rule is general.*

Being in Column of Fours, to Form Line by Two Movements.

293. In forming line by two movements the command *march* is given as the head of a company is about to change direction.

The adjutant or sergeant major at the rear of the column assures the positions

or the guides of the rear companies, in prolongation of the line of the leading companies.

A Part of the Column Having Changed Direction to the Right, to Form Line to the Left.

294. 1. *Fours left*, 2. *Rear companies left front into line*, 3. MARCH.

The companies that have changed direction wheel by fours to the left; each captain halts his company as the fours unite in line.

The rear companies execute *left front into line*, as prescribed.

To Form Line Faced to the Right.

295. 1. *Fours right*, 2. *Rear companies left front into line, faced to the rear*, 3. MARCH.

The companies that have changed direction wheel by fours to the right and halt.

The rear companies execute *left front into line, faced to the rear*.

296. If the column has changed direction to the left, to form line to the right: 1. *Fours right*, 2. *Rear companies right front into line*, 3. MARCH.

To Form Line to the Left.

297. 1. *Fours left*, 2. *Rear companies right front into line, faced to the rear*, 3. MARCH.

Being in Line, to Form Column of Companies to the Right or Left and Halt.

298. 1. *Companies right (or left)*, 2. MARCH.

Each company executes the *turn and halt* (Par. 192).

Full distance in column of subdivisions is such that in forming line to the right or left the subdivisions will

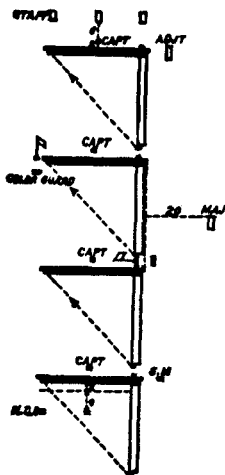

Pl. 47, Par. 298.

Whenever a guide in column is forced out of the direction, he recovers it gradually; the guides in rear conform successively to his movements.

Whenever the guide in column is changed, the adjutant and sergeant major, unless otherwise directed, pass by the most convenient line to the opposite flank.

These rules are general.

Being in Line, to break by the Right or Left of Companies to the Rear into Column.

301. 1. *Right (or left) of companies rear into column,* 2. MARCH.

Each captain commands: 1. *Fours right,* 2. *Column right.*

Each captain halts on the line lately oc-

have their proper intervals; in column of companies it is company distance and three paces.

Being in line, to form Column of Companies without Halting,

299. 1. *Companies,* 2. *Right (or left) turn,* 3. MARCH, 4. *Forward,* 5. MARCH, 6. *Guide (right or left).*

Each company executes the *turn and advance.* The fifth command is given when all the companies have completed the turn.

300. In column of subdivisions the guide of the leading subdivision is charged with the step and direction; the guides in rear preserve the trace, step, and distance.

Whenever a guide is

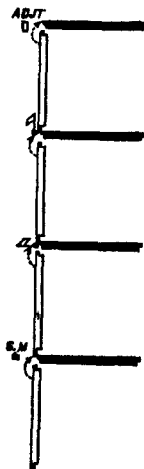

Pl. 48, Par. 301.



cupied by the front rank and as his rear four passes him, forms line to the left, halts his company, and dresses it to the left.



Marching in Column of Fours. to Form Companies Successively to the Right or Left into column at full distance.



302. 1. Column of companies, 2. First company, 3. Fours right (or left), 4. MARCH, 5. Guide right (or left).

The leading company executes *fours right*.



The other companies continue the march in column of fours and successively form line to

Pl. 49, Par. 302.

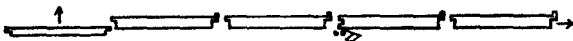

the right and move forward on the same ground as the leading company.



Marching in Column of Companies at Full Distance, to Form the Companies Successively to the Right or Left into Column of Fours.



303. 1. Column of fours, 2. First company, 3. Fours right (or left), 4. MARCH.

The leading company executes *fours right*.



Pl. 50, Par. 303.

The other companies continue the march in column of companies and successively form column of fours to the right, on the same ground as the leading company.

Being in Line, to Break by Companies from the Right or Left to March to the Left or Right.

304. Being at a halt: 1. *Companies break from the right (or left) to march to the left (or right)*, 2. **MARCH.**

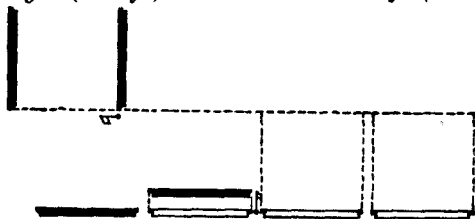

The captain of the first company commands: 1. *Forward*, 2. *Guide left*.

The right company moves forward, the cap-

Pl. 51, Par. 304.

tain commanding: 1. *Left turn*, 2. **MARCH**, when the guide has advanced company distance; the left guide then directs his march parallel to the front of the battalion.

Each of the other companies executes the same movements in time to follow the preceding company at full distance.

To March in Column at Full Distance.

305. 1. *Forward*, 2. *Guide (right or left)*, 3. **MARCH.**

To make a slight change of direction, the major commands: *Incline to the right (or left)*, and indicates the new line of direction; the leading guide gradually advances the left shoulder, his subdivision conforming to his movements. The rear subdivisions execute the change of direction on the same ground and in the same manner as the leading one.

To Halt the Column.

306. 1. *Battalion*, 2. **HALT.**

The column halts, and the guides stand fast, although they may have lost distance and be out of the direction of the guides in front.

To Face the Column to the Rear, and to March it to the Rear.

307. 1. *Fours right* (or *left*) *about*, 2. **MARCH**, 3. *Battalion*, 4. **HALT**; or, 3. *Guide* (*right* or *left*).

If the companies are unequal in size, each captain assists his guide to gain the trace and distance by obliquing his company when necessary, causing it to lengthen or shorten the step.

Being in Column at Full Distance, to Change Direction.

308. Being in march: 1. *Column right* (or *left*), or, 1. *Column half right* (or *half left*), 2. **MARCH**.

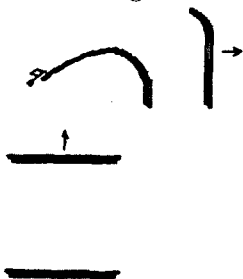

The chief of the first subdivision commands: *Right turn*.

The leading subdivision turns to the right, the chief adding: 1. *Forward*, 2. **MARCH**, upon its completion (see Par. 228).

The other subdivisions march squarely up to the turning point and each changes direction by the same commands and means as the first.

Pl. 52, Par. 308.

To Put the Column in March and Change Direction at the Same Time.

309. 1. *Forward*, 2. *Guide right* (or *left*), 3. *Column right* (or *left*); or, 3. *Column half right* (or *half left*), 4. **MARCH**.

Being in Column at Full Distance, to Form Line to the Right or Left.

310. The guides on the side toward which the movement is to be made covering at full distance, to form line and halt: 1. *Companies right* (or *left*), 2. **MARCH**, 3. *Guides*, 4. **POSTS**.

At the first command the left guide of the leading company places himself facing the leading guide of the column, nearly company distance in front of him, so as

to be opposite one of the left files of his company when the movement is completed ; the guide is assured in his position by the adjutant or sergeant major ; each captain places himself facing to the front, on the right of his company, and verifies the alignment.

At the command *posts*, the guides return to their posts in line.

To form line and advance : 1. *Companies*, 2. *Right (or left) turn*, 3. **MARCH**, 4. *Guide center*, 5. *Forward*, 6. **MARCH**.

The sixth command is given when all the companies have completed the turn

311. Being in column at full distance at a halt, if the guides do not cover or have not their proper distances, to correct them the major establishes the guide of the leading company and the guide next in rear in the desired direction, and commands : 1. *Right (or left) guides*, 2. **COVER**. The right guides place themselves covering the first two, each at full distance from the guide next in front ; the adjutant and sergeant major assure their positions ; the major then commands : 1. *Right (or left)*, 2. **DRESS**.

Each captain aligns his company on the guide and commands : **FRONT**.

Should any company be at a considerable distance from its guide, the captain gives the preparatory commands for moving it into place, adding : **MARCH**, at the command *dress* from the major.

Being in Column at Full Distance, to Form on Right or Left into Line.

812. Being in march : 1. *On right (or left) into line*, 2. **MARCH**.

The captain of the first company commands : *Right turn*, and when the company has advanced to the guides halts it.

The other companies continue the march, each captain

giving the commands: 1. *Right turn*, 2. *MARCH*, upon arriving opposite the right of his place in line.

Being at a halt at the first command, captains of

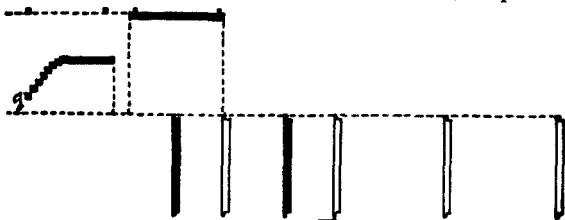

Pl. 53, Par. 312.

companies in rear of the first command: 1. *Forward*, 2. *Guide right*.

Being in Column at Full Distance, to Form Front into Line.

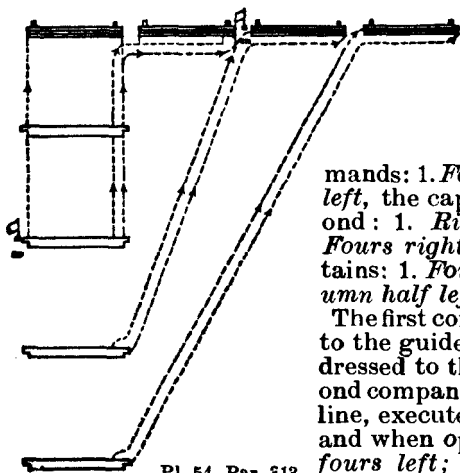

Pl. 54, Par. 313.

313. Being at a halt: 1. *Right (or left) front into line*, 2. *MARCH*.

The captain of the first company commands: 1. *Forward*, 2. *Guide left*, the captain of the second: 1. *Right forward*, 2. *Fours right*, the other captains: 1. *Fours right*, 2. *Column half left*.

The first company advances to the guides, is halted and dressed to the left. The second company, when near the line, executes *column right*, and when opposite its place, *fours left*; is halted and dressed to the left.

The other companies on nearing the line change direction half right and complete the movement as prescribed for the second company.

If marching, the captain of the first company omits the command *forward*, and changes the guide if necessary.

314. To form faced to the rear, the major adds *faced to the rear after front into line*.

Executed as above, except that the companies march just beyond the line, halt and wheel about by fours, halt, and dress toward the point of rest.

To Change Front.

315. Being in line: 1. *Change front on first (or fourth) company*, 2. *Companies*, 3. *Right (or left) half turn*, 4. *MARCH*, 5. *Guide right (or left)*.

The first company executes *right turn*.

The other companies execute *right half turn*; each captain again commands: *Right half turn*, 2. *MARCH*, when the right of his company is opposite its place in line.

316. The change of front may be effected by wheeling by fours and forming front into line.

317. To change front faced to the rear, the major adds *faced to the rear* to the command *change front on first (or*

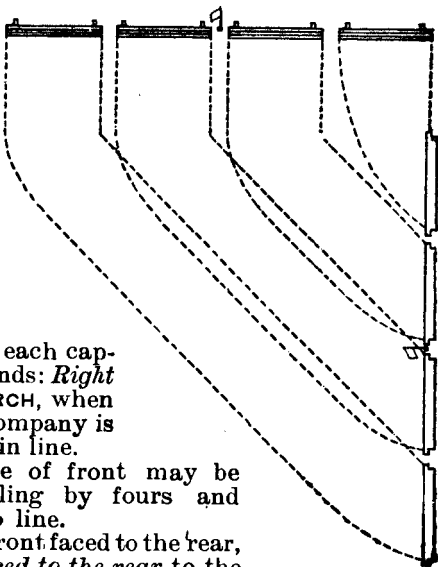

fourth) company. The movement is executed as just explained, except that the companies are marched across the line, halted just beyond it, wheeled about by fours, halted, and dressed as before.

318. The major may direct the guides to be posted in an oblique direction; the movement will be executed in the same manner, the designated company conforming to the line established by the guides.

To March in Route Step and at Ease.

319. To march in the route step and at ease and to resume the attention are executed as prescribed in the School of the Company. When marching in column of subdivisions the guides maintain the trace and distance.

In route marches the major, adjutant, and sergeant major march at the head of the column; the surgeon and hospital steward at the rear of the column; the other staff and non-commissioned staff officers, wherever the major directs; the band in front of the leading company; the captains at the head or rear of their companies, as directed by the major.

Being in Line, to Advance in Line of Companies in Columns of Fours.

320. 1. *Companies*, 2. *Right (or left) forward*, 3. *Fours right (or left)*, 4. **MARCH**, 5. *Guide (right, left or center)*.

Each company executes *right forward, fours right*; the guides preserve the interval necessary to form front into line, and march abreast of the guide indicated.

321. The line of columns of fours is *put in march, halted, marched to the rear, and at the oblique* by the same commands and means as the battalion in line.

Marching in Line of Companies in Columns of Fours, to Gain Ground to the Right or Left and Front.

322. 1. *Companies*, 2. *Column half right (or half left)*, 3. **MARCH**.

To resume the original direction: 1. *Companies*, 2. *Column half left (or half right)*, 3. **MARCH**.

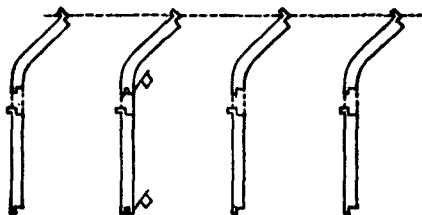

Pl. 56, Par. 322.

The companies regulate their movements by those of the company toward which the movement is made, as when obliquing. On resuming the direct march the guide is again announced.

Marching in Line of Companies in Columns of Fours, to Change Direction.

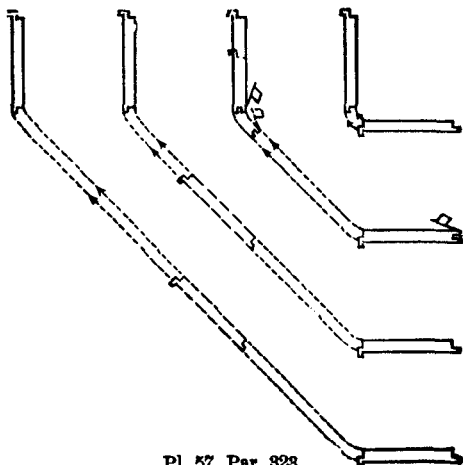

Pl. 57, Par. 323.

323. 1. *Change direction to the right (or left)*, 2. **MARCH**, 3. *Battalion*, 4. **HALT**; or, 3. *Guide (right, left, or center)*.

The first company changes direction to the right; the other companies are conducted by the shortest line to their places abreast of the first.

If marching in double time or in quick time and the command be *double time*, the captain of the first company cautions: *Quick time*; the other companies execute the movement in double time, and on arriving abreast of the first company their captains command: 1. *Quick time*, 2. MARCH. During the movement the guide is on the side toward which the change is made; on its completion the major announces the guide. If the command *halt* be given during the execution of the movement, only those companies halt that have arrived in place; the others successively halt upon arriving on the line.

Marching in Line of Companies in Columns of Fours, to Form Line.

324. 1. *Companies*, 2. *Right (or left) front into line*, 3. MARCH. 4. *Battalion*, 5. HALT.

Each company executes *right front into line*.

The command *halt* is given when the leading fours have advanced company distance.

If executed in double time, the major announces the guide immediately after the command *march*.

Marching in Column of Fours, to Form Front into Line of Companies in Columns of Fours.

325. 1. *Right (or left) front into line of companies in columns of fours*, 2. MARCH.

The captain of the first company cautions: *Continue the march*; the other captains command: *Column half right*; the first company having advanced company distance is halted; when the other companies have gained full intervals they execute *column half left*,

and halt abreast of the first company. If at a halt, each captain gives the commands necessary for putting his company in march.

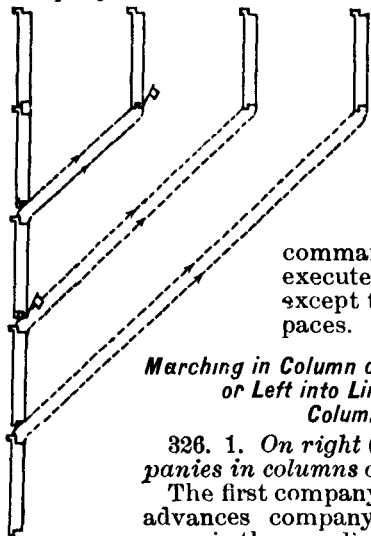

In advancing in line of columns of fours the intervals between guides at full and close interval are the same as the full and close distance in column.

To form at close interval the major adds at close interval to the first command; the movement is executed in the same manner, except that the interval is eight paces.

Marching in Column of Fours, to Form on Right or Left into Line of Companies in Columns of Fours.

326. 1. *On right (or left) into line of companies in columns of fours*, 2. MARCH.

The first company executes *column right*, advances company distance and twelve paces in the new direction and is halted; each of the other companies marches beyond the preceding company, executes *column right* when opposite its place, and is halted abreast of the first company. If at a halt, captains give the commands necessary for putting their companies in march.

Marching in Line of Companies in Columns of Fours, to March in Column of Companies to the Right or Left.

327. 1. *Fours right (or left)*, 2. MARCH, 3. *Guide (right or left)*.

Being in Column of Companies, to March in Line of Companies in Columns of Fours to the Right or Left.

328. 1. *Fours right* (or *left*), 2. MARCH, 3. *Guide* (*right, left, or center*).

Marching in Column of Fours, to March in Line of Companies in Columns of Fours to the Right or Left.

329. 1. *Companies*, 2. *Column, right* (or *left*), 3. MARCH, 4. *Guide* (*right, left, or center*).

To march again in column of fours: 1. *Companies*, 2. *Column right* (or *left*), 3. MARCH.

Being in Column of Companies, to Form Column of Fours and to Form Again in Column of Companies.

330. 1. *Companies*, 2. *Right*, (or *left*) *forward*, 3. *Fours right* (or *left*), 4. MARCH.

To form again in column: 1. *Companies*, 2. *Right* (or *left*) *front into line*, 3. MARCH, 4. *Battalion*, 5. HALT; or, if executed in double time, 4. *Guide left* (or *right*).

The companies execute these movements simultaneously.

331. All the movements prescribed in Pars. 319 to 330 may be executed by platoons, substituting *platoons* for *companies* in the commands and explanations.

Advancing in Line of Companies in Columns of Fours, to Close and Extend Intervals.

332. To close intervals: 1. *On* (such) *company close intervals*, 2. MARCH, 3. *Battalion*, 4. HALT, or, 3. *Guide* (*right, left, or center*).

The captain of the designated company cautions: *Continue the march*, the captains to the right command: *Column half left*; those to the left: *Column half right*.

The designated company halts at the fourth command; the other companies incline toward it until they

gain the close interval, when by command of their captains they change direction, half right or half left, march to the front and halt on arriving abreast of the one designated.

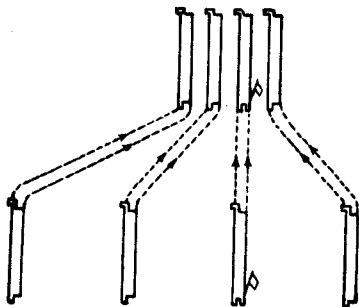

Pl. 59, Par. 332.

If marching in double time or in quick time, and the command be *double time*, the captain of the designated company cautions: *Quick time*; the other companies move in double time, and when they arrive abreast of the designated company take quick time.

Intervals are extended, gaining ground to the front, on the same principles: 1. *On* (such) *company extend intervals*, 2. **MARCH**, 3. *Battalion*, 4. **HALT**, or, 3. *Guide* (*right, left, or center*).

To Close Intervals without Gaining Ground to the Front.

333. The major wheels the battalion by fours into column of companies, the column is then closed, as in Par. 335, after which the battalion is wheeled by fours into line of columns of fours.

Intervals may be extended on the same principles.

The battalion is wheeled by fours into close column, and full distance taken as in Par. 336, after which the battalion is wheeled by fours into line of columns of fours.

Close Column or in Mass.

334. The distance between companies in close column is eight paces.

Whenever a subdivision takes its place in close column, the file closers close to one pace from the rear

rank, falling back to two paces whenever the full distance is again taken.

These rules are general.

Being in Column of Companies at Full Distance, and at a Halt, to Form Close Column.

335. 1. *Close in mass*, 2. *Guide right* (or *left*), 3. **MARCH.**

The captain of the first company cautions: *Stand fast*, the other captains command: 1. *Forward*, 2. *Guide right*.

The rear companies move forward; each is halted when it arrives at eight paces from the one that precedes it; each captain establishes his guide and dresses his company to the right.

If marching, the major omits the command for the guide and the captains of the rear companies omit the commands for putting them in march.

At the command *march*, the first company is halted.

If marching in quick time, and the command be *double time*, the captain of the first company cautions it to advance in quick time; each of the other captains commands: 1. *Quick time*. 2. **MARCH**, upon closing to eight paces.

If marching in double time, the movement is executed in the same manner; the captain of the first company commands: *Quick time*, at the first command of the major.

To arrest the march during the execution of the movement: 1. *Battalion*, 2. **HALT.**

Only those companies halt that have closed to eight paces; the other companies halt successively at the commands of their captains, upon closing to eight paces.

To close the column on the rearmost company, the major wheels the battalion about by fours; the column

is then closed as before; when closed, the battalion is again wheeled about by fours.

Being in Close Column, to Take Full Distance.

336. Being at a halt: 1. *Take full distance*, 2. *Guide right* (or *left*), 3. **MARCH**.

The captain of the first company commands: 1. *Forward*, 2. *Guide right*.

Each of the other captains commands: 1. *Forward*, 2. *Guide right*, 3. **MARCH**, when his company is at full distance.

If marching, the major omits the command for the guide.

If marching in quick time the captains of the companies in rear of the first halt them at the command *march*, and put them in march as above explained.

If marching in quick time and the command be *double time*, the captain of the first company commands *double time*, the other captains caution their companies to continue the quick time, and successively command: 1. *Double time*, 2. **MARCH**, when at full distance.

If marching in double time, the first company advances in double time; the captains of the other companies command: *Quick time*, at the first command of the major, and successively command: 1. *Double time*, 2. **MARCH**, when at full distance.

To form line to or on the right or left, the major first causes the column to take full distance.

To Ploy into Close Column.

337. Close column is always ployed with the designated or leading company in front.

The adjutant or sergeant major nearest the designated company places himself in front of the leading guide and assures the position of the other guides.

Being in Line, to Ploy into Close Column.

338. Being at a halt: 1. *Close column on first company*, 2. *Fours right*, 3. **MARCH.**

The captain of the first company commands: 1. *Forward*, 2. *Guide left*.

The first company advances twelve paces, is halted and dressed to the left; the other companies execute *fours right*.

The captain of the second company halts in rear of the left of the first, and when his rear four passes him, forms line



Pl. 61, Par. 338.

to the left, halts the company, establishes his left guide eight paces in rear of the left guide of the first, and dresses his company to the left.

The other companies incline to the right and each marches by the shortest line to a point eight paces in rear of the left guide of the preceding company, inclines to the left and executes what has been prescribed for the second company.

The closed column is ployed on the fourth company, by similar commands and means. The companies are dressed to the right.

If marching, the captain of the designated company cautions: *Continue the march*; the movement is executed as explained.

Being in Column of Fours, to Ploy into Close Column, Faced to the Front.

339. 1. *Close column*, 2. *First company*, 3. *Column right (or left)*, 4. **MARCH.**

The first company executes *column right* and the leading guide having advanced twelve paces in the new

direction, the captain halts and as his rear four passes him, forms line to the left, halts the company, and dresses it to the left.

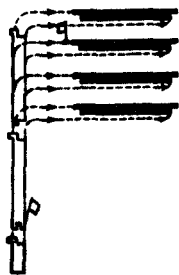

Pl. 62, Par. 339.

Each of the other companies moves forward and executes *column right*, so as to enter the column eight paces in rear of the preceding company, forms line to the left and is dressed to the left.

If at a halt, each captain gives the commands necessary to put his company in march.

Close column may be formed in an oblique direction on the same principles by substituting the command: 3. *Column half right* (or *half left*), for 3. *Column right* (or *left*).

340. To form the close column faced to the rear, the major adds: *Faced to the rear after close column*, in his commands.

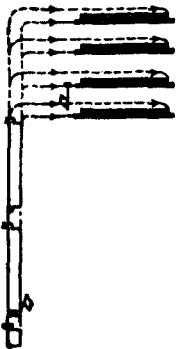

Pl. 63, Par. 340.

The movement is executed as just explained, except that the companies in rear of the first successively enter the column beyond the point where the first changed direction, and each captain forms his company in line to the right or left and dresses it to the right or left according as the company changed direction to the right or left.

Being in Column of Fours, to Ploy into Close Column, Faced to the Right or Left.

341. 1. *Close column*, 2. *First company*, 3. *Fours right* (or *left*), 4. MARCH.

The first company executes *fours right*, the captain commands: *Guide right*, and the company having advanced eight paces in the new direction is halted and

dressed to the right; the other companies form close column as prescribed in Par. 338.



Pl. 64, Par. 841.

If at a halt, captains give the commands necessary for putting their companies in march.

Being in Close Column, to Form Column of Fours.

342. Being at a halt: 1. *Column of fours*, 2. *First company*, 3. *Right (or left) forward*, 4. *Fours right (or left)*, 5. **MARCH**.

The first company executes *right forward, fours right*.

Each of the other companies executes the same movement in time to follow the one preceding.

The major may command: 1. *Columns of fours*, 2. *First (or Fourth) company*, 3. *Fours right (or left)*, 4. **MARCH**.

The designated company executes *fours right*.

Each of the other companies executes *fours right, or right forward, fours right*, in time to follow the one preceding.

Movements in Close Column.

343. A close column advances, halts, obliques, marches by the flank and resumes the march in column, faces to the rear, marches to the rear, changes direction, gains ground to the right or left when marching by the flank and resumes the original direction by the same commands and means as a column at full distance.

Being in Close Column, to Change Direction by the Flank.

344. 1. *Change direction by the right (or left) flank*, 2. *Fours right (or left)*, 3. **MARCH**.

The captain of the first company commands: 1. *Right forward*, 2. *Fours right*.

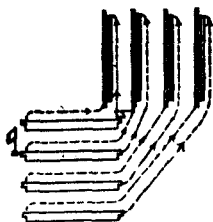

Pl. 65, Par. 344.

The first company executes *right forward, fours right*; the captain, as the rear four completes its wheel to the front, forms the company in line to the left, halts it and dresses it to the left.

The other companies execute *fours right* and direct their march so as to enter the new column eight paces in rear of and parallel to the first company; each captain halts when opposite the left guide of the preceding company and allows his company to march past him, forms it in line to the left and dresses it to the left.

The first company may, by order of the major, be inclined at any angle to the original front. By this method any direction may be given to a close column.

345. The close column marching by the flank changes direction by the same commands and means as when at full intervals (Par. 323).

To Deploy the Close Column.

346. Being at a halt: 1. *Deploy column*, 2. *Fours right* (or *left*), 3. **MARCH**.

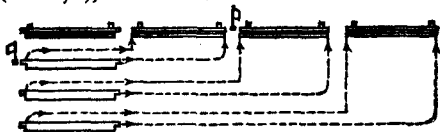

Pl. 66, Par. 346.

The captain of the first company cautions: *Stand fast*.

The first company is dressed to the left: the other companies execute *fours right*; each captain halts when three paces beyond the right of the preceding company, and as the rear of his company passes him, wheels it by fours to the left, halts it near the line and dresses it to the left.

If marching, the captain of the first company halts it at the command *march*; the movement is executed as before.

347. To deploy the column faced to the rear without first causing it to wheel about by fours, the major adds the command: *Faced to the rear, after deploy column.*

The movement is executed as already explained, except that each company marches just beyond the line, halts, and then wheels about by fours, after which it is dressed toward the point of rest.

Movements by Platoons.

348. The major may form the battalion in column of platoons to the right or left, form line from column of platoons to the right or left, form column of fours from column of platoons, and the reverse, by the commands and means prescribed in the School of the Company.

Being in Column of Companies, at Full Distance, to Break into Column of Platoons.

349. 1. *Right (or left) by platoons*, 2. MARCH, 3. *Guide left (or right).*

Executed by each company as in Par. 235.

350. To reform the companies: 1. *Form companies*, 2. *Right (or left) oblique*, 3. MARCH, 4. *Battalion*, 5. HALT; or, 4. *Guide left (or right).*

Executed by each company, as in Par. 236, except that when executed in quick time the chiefs of the leading platoons do not halt them till the command *halt* from the major.

351. Distances are taken and closed in column of platoons as in column of companies.

Being in March in Column of Platoons, to Form on Right or Left into Line.

352. 1. *On right (or left) into line*, 2. MARCH.

The first company executes *on right into line* (Par. 284), halting at the guides (Par. 288, a and c); the other companies march beyond the first, each captain commanding: 1. *On right into line*, 2. MARCH, upon arriving opposite his place in line.

If executed from a halt, the captains of companies in rear of the first command: 1. *Forward*, 2. *Guide right*.

Marching in Column of Platoons, to Form Front into Line.

353. 1. *Right (or left) front into line*, 2. MARCH.

The captain of the first company commands: 1. *Form company*, 2. *Right oblique*; the other captains command: *Column half right*. The first company is halted and dressed to the left against the guides; each of the other companies executes *column half right*, advances in the new direction until the left of its first platoon is opposite its place in line, when the company changes direction half left, and when at platoon distance from the line forms company as prescribed for the first company.

If executed from a halt, the captains of companies in rear of the first command: 1. *Forward*, 2. *Guide left*, 3. *Column half right*.

To Form Line of Platoon Columns.

354. A platoon column is a company in column of platoons.

The *full interval* between companies in line of platoon columns is platoon front and three paces; the *close interval* is eight paces; full interval is taken unless close is specified in the commands.

355. Advancing in line of platoon columns, intervals are closed and extended by the commands and means prescribed in Par. 332.

To close intervals without gaining ground to the front: 1. *On (such) company, close intervals*, 2. MARCH.

The designated company stands fast.

Each of the other companies moves by the flank toward the designated company, inclining slightly to the rear, and when at twelve paces from the preceding company is wheeled by fours to the front and halted and dressed on the line of the designated company.

Intervals are extended on the same principles.

Being in Line to Advance in Line of Platoon Columns with Full Intervals.

356. 1. Companies, 2. Right (or left) by platoons, 3. MARCH, 4. Guide (right, left, or center).

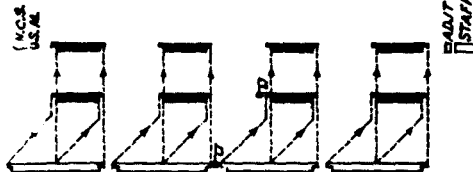

Pl. 67, Par. 356.

The captains announce the guide on the flank toward the base company; if the guide be center, the captain of the right

center company cautions: *Guide left.*

357. The line of platoon columns advances, halts, faces to the rear, marches to the rear, and changes direction by the same commands and means as prescribed for a line of columns of fours.

Being in Line of Platoon Columns, to Form Line.

358. 1. Form companies, 2. Right (or left) oblique, 3. MARCH, 4. Battalion, 5. HALT, or 4. Guide center.

Executed by each company as in Par. 236.

If executed in double time, the major commands: *Guide center*, as soon as the rear platoons arrive on the line.

Being in Line of Platoon Columns, to Form Column of Companies to the Right or Left.

359. 1. Platoon right or left), 2. MARCH.

Being in Column of Companies at Full Distance, to Form Line of Platoon Columns to the Right or Left.

360. 1. *Platoons right (or left)*, 2. MARCH.

Marching in Line of Platoon Columns, to Form Column of Platoons to the Right or Left.

361. 1. *Companies*, 2. *Column right (or left)*, 3. MARCH, 4. *Guide right (or left)*.

To march again in line of platoon columns: 1. *Companies*, 2. *Column right (or left)*, 3. MARCH, 4. *Guide (right, left, or center)*.

Being in Column of Platoons to Form on Right or Left into Line of Platoon Columns.

362. 1. *On right (or left) into line of platoon columns*, 2. MARCH.

The first company changes direction to the right, and when the leading platoon has advanced company distance, the captain commands: 1. *Company*, 2. HALT.

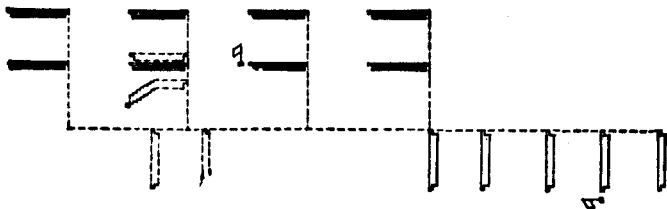

Pl. 68, Par. 362.

Each of the other companies marches beyond the preceding company, changes direction, and forms on its left at the proper interval.

Being in Column of Platoons, to Form Front into Line of Platoon Columns.

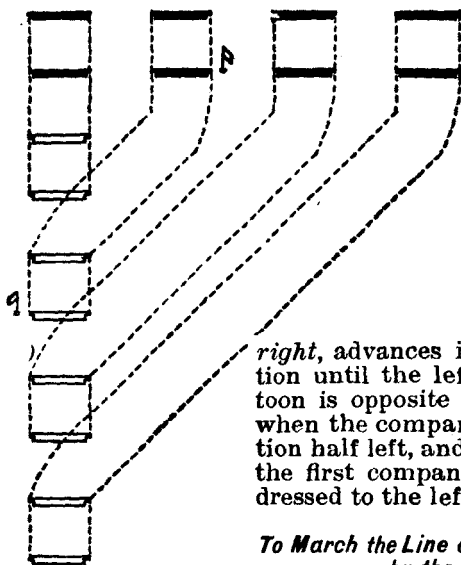

Pl. 69, Par. 363.

363. 1. *Right (or left) front into line of platoon columns,* 2. **MARCH.**

The first company advances company distance, is halted and dressed to the left; each of the other companies executes *column half*

right, advances in the new direction until the left of its first platoon is opposite its place in line, when the company changes direction half left, and when abreast of the first company is halted and dressed to the left.

To March the Line of Platoon Columns by the Flank.

364. 1. *Fours right (or left),* 2. **MARCH,** 3. *Guide right (or left).*

To march again in line of platoon columns: 1. *Fours right (or left),* 2. **MARCH,** 3. *Guide right (left, or center).*

Marching by the Flank, to Form Line of Companies in Columns of Fours.

365. 1. *Platoons,* 2. *Column right (or left),* 3. **MARCH,** 4. *Guide (right, left or center).*

Being in Column of Fours, to Form Front into Line of Platoon Columns.

366. 1. *Right (or left) front into line of platoon columns, 2. MARCH*

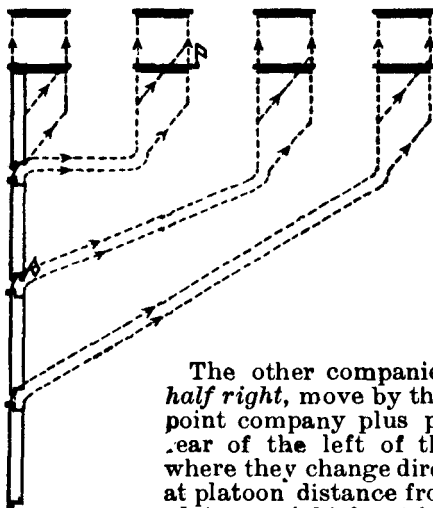

The first company executes *platoons right front into line* (Par. 243). The second company executes *column right*; when its leading guide is opposite his place in line, *column left*; and when at platoon distance from the line, *platoons right front into line*.

The other companies execute *column half right*, move by the shortest line to a point company plus platoon distance in rear of the left of their places in line, where they change direction half left, and at platoon distance from the line execute *platoons right front into line*.

Pl. 70, Par. 366.

To Form Street Column.

367. Being in column of companies at full distance: 1. *Street column, 2. MARCH*. The first company halts and stands fast; the second forms in column of fours, four paces in rear of the right four of the first company; the third forms similarly in rear of the left four of the first company; the fourth company closes upon the second and third; all the officers, the color guard, non-commissioned staff, guides, and file closers take post

within the column, captains opposite the centers of their companies, the others near their posts in line or column.

Being in column of fours : 1. *Street column*, 2. *Right* (or *left*) *front into line*, 3. MARCH. The first and fourth companies execute *right front into line*, and the formation is completed as prescribed.

The numbers of the companies remain unchanged till column of companies or fours is again formed.

If there be but three companies in the battalion, the first and second platoons of the second company execute what is prescribed for the second and third companies, and the third company closes upon the second.

With five companies, the platoons of the fourth company form in rear of the second and third companies, as above prescribed for the platoons of the second company, and the fifth company closes upon the fourth.

With six companies, the fourth company forms column of fours and follows the second, the fifth follows the third, and the sixth closes upon the fourth and fifth.

The street column *advances, obliqués, changes direction, halts, and marches by the flank and to the rear* by the same commands and means as a column at full distance; in marching by the flank the flank companies oblique sufficiently to follow in rear of the flank fours of the leading company, the right or left front rank man of the leading company acts as guide, and in changing direction the rear company regulates its movements on the companies in columns of fours.

To Form Square.

Being in street column : 1. *Form square*, 2. MARCH. The leading company halts or stands fast; the right and left flank companies wheel by fours to the right and left, respectively, and halt; the rear company executes *about face*.

To form again in street column: 1. *Street column*, 2. **MARCH**.

The company that was leading when the square was formed stands fast; the rear company executes *about face*; the right and left flank companies wheel by fours to the left and right, and halt; they regain their positions when the column marches.

Being in street column, to form column of companies at full distance: 1. *Column of companies*, 2. **MARCH**, 3. *Guide right (or left)*. The first company advances, the flank companies execute front into line in double time, each when at full distance from the preceding company, and the rear company advances when at full distance. Officers, guides, etc., return to their posts.

The street column forms column of fours by the commands prescribed in Par. 342. The designated company executes the movement, the other companies take their proper places in column of fours, with file closers on the same flank as in the designated company. Officers, guides, etc., resume their posts in column.

EVOLUTIONS OF THE REGIMENT.

368. The regiment is supposed to consist of three battalions, but the rules prescribed are applicable to a less or greater number.

The colonel is the instructor.

Posts of Field Officers, Regimental Staff, Non-commissioned Staff, and Band.

369. In line, and in line of columns, the colonel is posted sixty paces in front of the line, opposite its center; in line of masses, this distance is reduced to thirty paces; in column, he habitually marches at the head of the regiment.

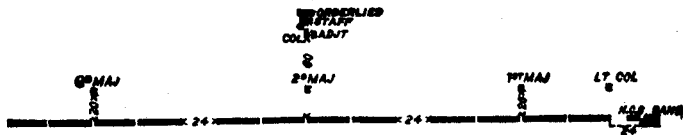

Pl. 71, Par. 369.

In line, in line of columns, or in line of masses, the lieutenant-colonel is posted on a line with the majors, opposite the right of the first battalion; in column, he is on the side of the guide, abreast of and twenty paces from the head; during field movements and on the march, he is not restricted to any particular post; he acts as an assistant to the colonel as the latter may direct.

The adjutant rides on the left of the colonel; the other staff officers ride six paces in rear of the colonel, in the order of rank, the senior on the right.

Mounted trumpeters and orderlies ride three paces in rear of the staff.

In line, the band is posted with the left of its front rank twenty-four paces to the right of the first battalion. In the evolutions, it takes, as far as practicable, the positions prescribed in the School of the Battalion, unless excused or a position is assigned to it by the colonel.

In line, the non-commissioned staff, the sergeant major on the right, form at one pace apart, abreast of the front rank of the band, the sergeant major six paces from its left.

In route marches, the colonel and staff march at the head of the column, the non-commissioned staff in their rear, or in rear of the mounted trumpeters and orderlies; the band in rear of the non-commissioned staff.

The colonel may direct a surgeon to march in rear of the regiment, or if there be a sufficient number, one in rear of each battalion. The quartermaster and quartermaster sergeant are usually with the train; the hospital stewards with the ambulances in rear of the regiment.

General Rules for Commands.

376. The colonel's commands are given orally, by the trumpet, or communicated by staff officers or orderlies. The majors, unless otherwise directed, repeat the commands of the colonel as soon as given; and add such commands and cause their battalions to execute such movements as may be necessary before the general movement.

Each major gives the commands necessary to insure the execution of the movements by his battalion at the proper time.

After the general movement, each major adds such commands as may be necessary to complete the movement in his battalion, such as *guides posts*, etc.

The colonel may preface his commands by : 1. *Battalions*, 2. ATTENTION. He may permit battalions to stand *at ease*, while awaiting the completion of the general movement by other battalions.

When the regiment is in more than one line, if a movement is to be executed by one of the lines, *first line, second line, or third line*, is specified in the preparatory command of the colonel; the battalion commanders in the designated line repeat the commands of the colonel.

When the formation will admit of the simultaneous execution of movements by battalions, the colonel may have them execute the movements prescribed in the School of the Battalion by prefixing the command *Battalions* to the commands therein prescribed.

When the formation will admit of the simultaneous execution of movements by companies or platoons, the movements are executed as in the School of the Battalion, the colonel giving the commands prescribed for the major, except that in announcing the guide, in line and in line of columns, he commands: (Such) *the base battalion*.

The colonel may designate a battalion to execute a separate movement by prefixing the command: (Such) *battalion* to the commands prescribed in the School of the Battalion.

Formation of the Regiment.

371. The regiment is formed by battalions, in line, in line of platoon columns, or in line of masses, at the discretion of the colonel.

It may also be formed in separate lines in any of the above formations.

At reviews and other forms of ceremony, the battalions are posted from right to left, according to the rank of battalion commanders present, the senior on the right. A battalion whose major is in command of the regiment, retains its place. On other occasions the battalions are posted at the discretion of the colonel.

The interval between battalions in line or in line of masses is twenty-four paces.

In whatever direction the regiment faces, the battalions are designated from the right when in line, and

the head when in column, *first battalion, second battalion*, and so on. If in two lines, the battalions in the first line are designated from the right, *first* and *second*; in the second line, *third*, and so on.

To receive the regiment, the colonel takes post, facing the line.

The adjutant indicates to the adjutant of the base battalion the point of rest and the direction of the line, then takes post facing the line, about thirty paces in front of the center.

The lieutenant-colonel and non-commissioned staff take post as the last battalion is formed. The formation completed, the adjutant commands: 1. *Battalions*, 2. **ATTENTION**, presents the regiment to the colonel as explained for presenting a battalion, and takes post with the colonel, passing by his right.

To Open and Close Ranks.

372. Being in line, at a halt: 1. *Open ranks*, 2. **MARCH**. To close ranks: 1. *Close ranks*, 2. **MARCH**. Executed in each battalion (Pars. 263 and 264), regulating on the first battalion.

Firings.

373. The firings are conducted by the battalion commanders (Pars. 265 to 268) under the direction of the colonel.

The colonel, lieutenant-colonel, and staff pass to the rear of the line.

Rests.

374. Executed as in the School of the Battalion (Par. 269).

To resume attention: 1. *Battalions*, 2. **ATTENTION**.

375. To dismiss the regiment: 1. *Dismiss your battalions*.

Each major conducts his battalion to its parade ground, where it is dismissed as prescribed.

To Advance.

376. Being in line, the colonel gives the commands prescribed in the School of the Battalion for advancing in line of columns.

The major of the base battalion adds: *Guide center*; the other majors announce the guide toward the base battalion, and regulate the march of their battalions upon it.

To reform the line, the colonel gives the same commands as a battalion commander, substituting *battalions*, *halt*, for *battalion*, *halt*.

To advance a short distance in line: 1. (Such) *the base battalion*, 2. *Forward*, 3. MARCH.

At the command *forward*, each major adds: *Guide center*.

The majors regulate the march of their battalions upon the base battalion.

To Face the Line to the Rear.

377. 1. *Face to the rear*, 2. *Fours right* (or *left*) *about*, 3 MARCH.

Each major halts his battalion as the fours unite in line.

To March the Line to the Rear.

378. 1. *Fours right* (or *left*) *about*, 2. MARCH, 3. (Such) *the base battalion*.

The majors add: *Guide center*, the instant the about is completed.

To Halt the Regiment.

379. 1. *Battalions*, 2. HALT.

Alignments

380. Being at a halt, to give a general alignment, the colonel selects a base company, posts its guides at the point of rest, in the desired direction and commands:

1. *Guides on the line*, 2. *On the center* (*right* or *left*), 3. DRESS.

At the first command, the guides of each company

post themselves as in forming the battalion, taking care to preserve the intervals.

At the command *dress*, each battalion is dressed as in Par. 280. Each major commands: 1. *Guides*, 2. **POSTS**, as soon as his battalion is dressed.

If a battalion be at a considerable distance from or in front of the position it is to occupy, its major will, at the first command, move it to its proper position for dressing.

Being in Line, to March by the Flank.

381. 1. *Fours right (or left)*, 2. **MARCH**.

Being in Line at a Halt, to Break into Column of Fours from the Right or Left to March to the Left or Right.

382. 1. *Column of fours*, 2. *Break from the right (or left) to march to the left (or right)*, 3. **MARCH**.

The first battalion executes the movement (Par. 284); the other battalions follow successively at the commands of their majors, each twenty-four paces in rear of the one preceding.

383. The regiment, in column of fours, *forms line to the right or left, advances, obliques, changes direction and marches to the rear*, as prescribed for the battalion.

384. The movements from column of fours are explained for execution on the march, but may be executed from a halt.

Successive Formations:

385. The adjutant or sergeant major of each battalion precedes it on the line to indicate the point of rest.

The guides of the leading company of the base battalion are first established.

The guides of the leading companies of the rear battalions are established facing the point of rest of the general line, the nearest guide being twenty-four paces from the flank of the battalion next preceding.

Distance, when forming two or more lines or column

of battalions, is the front of the battalion in line and twenty-four paces. This may be increased or diminished, the colonel adding to his first command: *At (so many) paces distance*; or, the colonel may send orders specifying the distance to the commanders of the second and third lines, or send a staff officer to indicate the points of rest.

When in two lines, the second line, in all maneuvers, preserves its position relative to the first, and conforms to its movements.

Marching in Column of Fours, to Form in Two Lines to the Right or Left.

386. 1. *In two lines*, 2. *Fours right (or left)*, 3. *Third (or such) battalion, second line*, 4. **MARCH.**

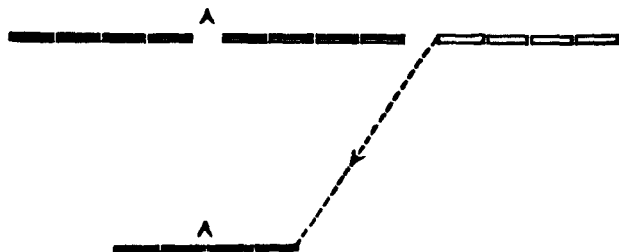

Pl. 72, Par. 386.

The first and second battalions form line to the right and halt. The third battalion inclines to the left until it gains the required distance, when it resumes the original direction, and is formed in line to the right and halted with its center in rear of the center of the first line.

To March again in Column of Fours.

387. 1. *Column of fours*, 2. *First line*, 3. *Fours right (or left)*, 4. **MARCH.**

The battalion commander of the second line commands: 1. *Fours right*, 2. MARCH, in time to follow the preceding battalion at the proper distance. The battalion is marched by the shortest line to its place in column.

Being in Column of Fours, to Form on Right or Left into Line.

388. 1. *On right (or left) into line*, 2. MARCH.

The leading battalion executes *on right into line*; the other battalions, at the commands of their majors, successively execute the same movement when their leading fours have passed beyond the left flank of the battalion preceding.

Being in Column of Fours, to Form in Two Lines on Right or Left.

389. 1. *In two lines*, 2. *On right (or left) into line*, 3. *Third (or such) battalion, second line*, 4. MARCH.

The first and second battalions execute the movement as already explained. The third battalion inclines to the left until it gains its distance, when it resumes the original direction, and forms on right into line in rear of the center of the first line.

Being in Column of Fours, to Form Front into Line.

390. 1. *Right (or left) front into line*, 2. MARCH.

At the first command, the majors of battalions in rear command: *Column half right*.

At the command *march*, the first battalion executes *right front into line*.

Each of the other majors so marches his battalion that when the head arrives opposite its point of rest it will be at least twice company distance in rear of the line when it changes direction half left, and on arriving at company distance from the line, the battalion executes *right front into line*.

Being in Column of Fours, to Form Front into Line, Faced to the Rear.

391. *Right (or left) front into line faced to the rear,*
 2. MARCH.

The first battalion executes *right front into line, faced to the rear*; the others are marched toward their points of rest (Par. 390), and formed right front into line, faced to the rear.

392. *Front into line and front into line faced to the rear* may also be executed on the rear of the column by first wheeling about by fours and then using the means already explained.

Being in Column of Fours, to Form Front into Line, on the Head of a Rear Battalion.

393. 1. *On second (or such) battalion;* 2. *Right (or left) front into line,* 3. MARCH.

At the second command, the major of the first battalion adds: *Fours left*; the major of the third: *Column half right*.

At the command *march*, the second and third battalions execute *right front into line* as previously explained. The first battalion marches twenty-four paces to the left, when the major forms column of fours to the left and immediately after commands: 1. *Right front into line, faced to the rear,* 2. MARCH.

If the third be designated, the second battalion executes the movements just prescribed for the first, the major of the first wheels his battalion about by fours, changes direction half right, and forms his battalion on the left of the line according to the principles laid down.

Being in Column of Fours, to Form Front into Line in Two Lines.

394. 1. *In two lines,* 2. *Right (or left) front into line,*
 3. *Third (or such) battalion, second line,* 4. MARCH.

The first and second battalions execute *right front*

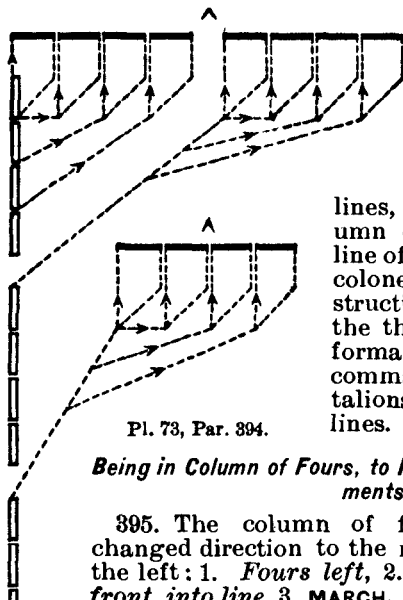

Pl. 73, Par. 394.

Being in Column of Fours, to Form Line by Two Movements.

395. The column of fours having partly changed direction to the right, to form line to the left: 1. *Fours left*, 2. *Rear battalions left front into line*, 3. **MARCH**.

The battalions that have changed direction to the

into line as already explained. The third battalion inclines to the right, and forms right front into line in rear of the center of the first line.

To form three lines, the third in close column of companies, or in line of platoon columns, the colonel sends special instructions to the major of the third battalion as to its formation, and gives the commands to the other battalions for forming in two lines.

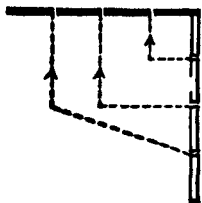

Pl. 74, Par. 395.

right form line to the left and halt; the battalions in rear execute *left front into line*, the leading fours advancing only so far as to be in line with the battalions that formed line to the left.

396. To form line to the right: 1. *Fours right*, 2. *Rear battalions left front into line, faced to the rear*, 3. MARCH.

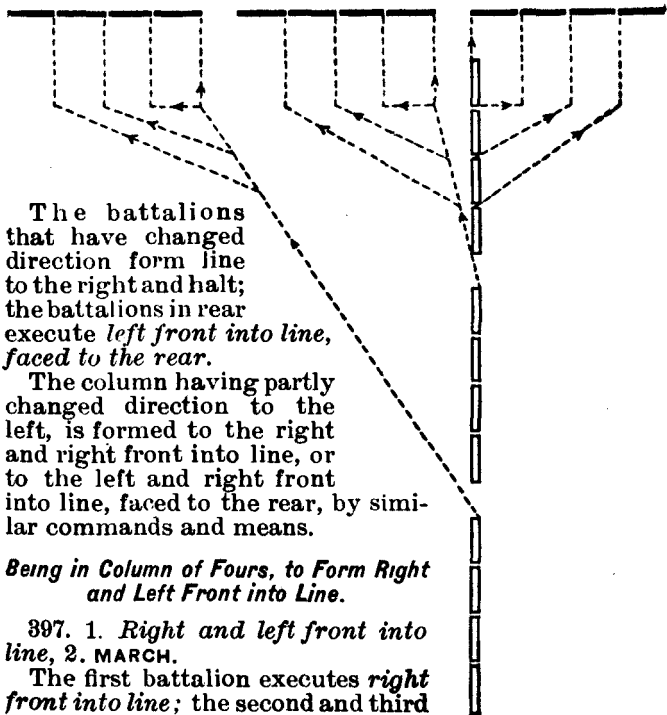

The battalions that have changed direction form line to the right and halt; the battalions in rear execute *left front into line, faced to the rear*.

The column having partly changed direction to the left, is formed to the right and right front into line, or to the left and right front into line, faced to the rear, by similar commands and means.

Being in Column of Fours, to Form Right and Left Front into Line.

397. 1. *Right and left front into line*, 2. MARCH.

The first battalion executes *right front into line*; the second and third are marched to the left; the second

forms left front into line on the left of the first; and the third forms left front into line on the left of the second.

If the colonel commands *left and right front into line*, the first battalion forms left front into line, the rear battalions form right front into line on the right of the first.

Being in Column of Fours, to Form Right and Left Front into Line in Two Lines.

398. 1. *In two lines*, 2. *Right and left front into line*, 3. *Third (or such) battalion, second line*, 4. MARCH.

The first battalion forms right front into line, the second forms left front into line on the left of the first; the third forms line by two movements (Pars. 293, 294, 296), and is established in rear of the center of the first line.

If the second command of the colonel be *left and right front into line*, the first battalion forms left front into line and the second forms right front into line on its right.

399. Being in column of fours, line of companies in columns of fours is formed according to the principles for forming line from column of fours.

In executing front, or on right or left, into line of columns of fours, each major marches his battalion opposite its point of rest, on the principles explained for forming the regiment front, or on right or left into line, and then forms into line of columns of fours, as in the School of the Battalion.

All movements in line of columns of fours, School of the Battalion, may be executed by the regiment by similar commands and means, the colonel designating (such) *battalion* when necessary.

Route Step and to March at Ease.

400. To march in route step and at ease and to resume attention are executed as prescribed for the battalion, substituting *battalions* for *battalion*.

Column at Full Distance.

401. The regiment being in line, forms column of companies or platoons to the right or left, or right or left of companies rear into column by the commands and means prescribed in the School of the Battalion (Par. 251).

The regiment being in column at full distance, advances, forms line to the right or left, and marches to the rear by the commands and means prescribed in the School of the Battalion.

Being in Column at Full Distance, to Change Direction.

402. Being in march: 1. *Column right (or left)*, 2. MARCH.

The leading battalion changes direction to the right; the other battalions move forward, and each at the command of its major changes direction on the same ground as the first.

Being at a halt: 1. *Forward*, 2. *Guide right (or left)*, 3. *Column right (or left)*, 4. MARCH.

Being in Column at Full Distance, to Face the Column to the Rear.

403. 1. *Face to the rear*. 2. *Fours right (or left) about*, 3. MARCH.

The majors add: 1. *Battalion*, 2. HALT, as the fours unite in line.

Being in Column at Full Distance, to Form on Right or Left into Line.

404. 1. *On right (or left) into line*, 2. MARCH.

The first battalion executes *on right into line*; the other battalions move forward and execute the movement successively, each when its leading company is twenty-four paces beyond the left flank of the battalion preceding.

405. Being in column of companies, the movements to form in two lines, on right or left, are executed by

the same commands and on the same principles as from column of fours (Par. 389).

Being in Column at Full Distance, to Form Front into Line.

406. 1. *Right (or left) front into line*, 2. MARCH.

At the first command the major of the first battalion

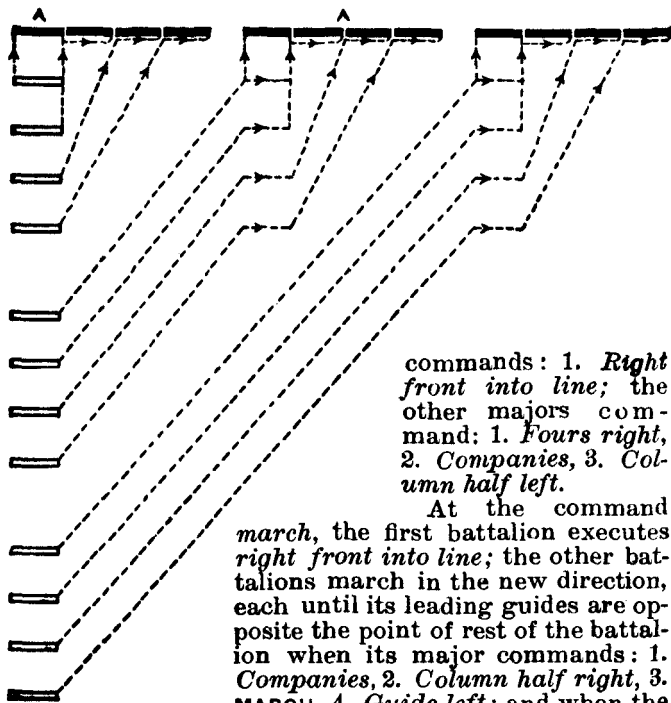

commands: 1. *Right front into line*; the other majors command: 1. *Fours right*, 2. *Companies*, 3. *Column half left*.

At the command *march*, the first battalion executes *right front into line*; the other battalions march in the new direction, each until its leading guides are opposite the point of rest of the battalion when its major commands: 1. *Companies*, 2. *Column half right*, 3. MARCH, 4. *Guide left*; and when the rear four of his left company is oppo-

Pl. 76, Par. 406.

site the point of rest, commands: 1. *Fours left*, 2. MARCH, 3. *Guide left*; and when at company distance from the line, forms his battalion right front into line on the right of the preceding battalion.

To Form Front into Line Faced to the Rear.

The colonel adds *faced to the rear*, after *front into line*; each major, when his battalion approaches the line, executes *right front into line faced to the rear*.

Right and left front into line is executed by the same commands and on the same principles as from column of fours (Par. 397).

Being in Column at Full Distance, to Form Front into Line, in Two Lines.

407. The colonel gives the same commands as when in column of fours, and the movement is executed according to the same principles.

Being in Column at Full Distance, to Form Line by Two Movements.

408. The column at full distance having partly changed direction to the right (or left) to form line to the left (or right).

1. *Companies left* (or right), 2. *Rear battalions left* (or right) *front into line*, 3. MARCH.

The battalions that have changed direction to the right form line to the left. The rear battalions execute *left front into line*.

409. The regiment being in line, forms line of companies or platoons in columns of fours, by the same commands and means as in the School of the Battalion.

The guides preserve the intervals necessary to form front into line with twenty-four paces between battalions. At close intervals the interval between battalions is company front.

To Ploy into Column of Masses.

410. In column of masses the distance of each battalion from the one preceding it is equal to the front of its first company.

In forming column of masses from line, the designated battalion ploys into close column; the others ploy in rear of the one designated, the battalion nearest the point of rest taking precedence in the column. The rear battalions are dressed to the same flank as the designated or leading battalion.

411. Column of companies at full distance is closed in mass by the commands and means prescribed in Par. 335; each battalion in rear of the first is closed in mass when at company distance from the one preceding.

412. Being in column of masses, full distance is taken by the commands and means prescribed in Par. 336; each battalion in rear of the first takes full distance when its leading company has company distance and twenty-four paces.

Being in Line, to Ploy into Column of Masses on the First Company of the First Battalion.

413. 1. *Column of masses*, 2. *On first company, first battalion*, 3. MARCH.

The first battalion ploys on its first company (Par. 338); the others wheel by fours to the right, incline to the right, and each marches so that its leading company may enter the column at company distance and eight paces in rear of the rear company of the preceding battalion. The second battalion ploys in rear of the first and the third in rear of the second, each as prescribed in the School of the Battalion (Par. 341); the left guides cover the left guides of the preceding battalion.

The regiment is ployed on the fourth company, third battalion, on the same principles.

Being in Line to Ploy into Column of Masses on an Interior Battalion.

414. 1. *Column of masses*, 2. *On first company, second battalion*, 3. **MARCH**.

The second battalion ploys on its first company.

The major of the first battalion commands: 1. *Fours, left*, 2. **MARCH**, 3. *Companies*, 4. *Column left*, 5. **MARCH**, 6. *Guide right*, and when his leading guides are opposite a point company distance and eight paces in rear

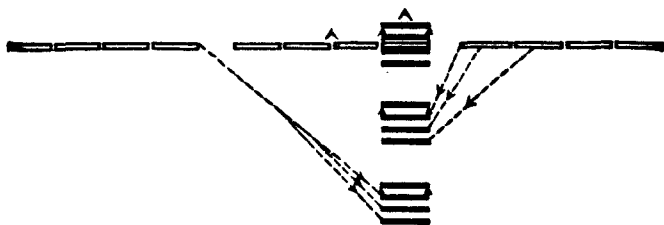

Pl. 77, Par. 414.

of the second battalion, commands: 1. *Companies*, 2. *Column right*, 3. **MARCH**, and ploys his battalion in rear of the second by the commands and means prescribed in Par. 341, except that the captains pass through the column, establish their left guides in rear of the left guides of the second battalion, and dress their companies to the left, and that the captain of the first company announces *guide left* as his company forms line.

The third battalion ploys in rear of the first on the principles explained in Par. 413.

Should the command of the colonel be :

1. *Column of masses*, 2. *On fourth company, second battalion*, 3. **MARCH**, the movement is executed on the same principles. The third battalion ploys in rear of the second, the first in rear of the third.

Being in Column of Fours, to Ploy into Column of Masses Faced to the Front.

415. 1. *Column of masses*, 2. *First company, first battalion*, 3. *Column right (or left)*, 4. **MARCH.**

The first battalion ploys faced to the front (Par. 339); each of the other battalions successively executes the same movement in rear of the preceding battalion.

Column of masses may be formed in an oblique direction on the same principles by substituting the command: 3. *Column half right (or half left)*; for 3. *Column right (or left)*.

Being in Column of Fours, to Ploy into Column of Masses, Faced to the Rear.

416. 1. *Column of masses faced to the rear*, 2. *First company, first battalion*, 3. *Column right (or left)*, 4. **MARCH.**

The first battalion ploys faced to the rear (Par. 340); the other battalions move forward and successively execute the same movement, each major giving his commands so that his first company may enter the column at a point company distance beyond the point where the last company of the preceding battalion entered it.

Being in Column of Fours, to Ploy into Column of Masses Faced to the Right or Left.

417. 1. *Column of masses*, 2. *First company, first battalion*, 3. *Fours right (or left)*, 4. **MARCH.**

The first battalion ploys faced to the right (Par. 341); the other battalions incline to the left and successively execute the same movement, each major giving his commands so that his first company may enter the column at company distance and eight paces in the rear of the rear company of the preceding battalion.

Being in column of companies or fours, column of masses is formed on the rearmost company by first

wheeling about by fours and then executing the movement as explained.

The column of masses *advances, halts, obliques, marches by the flank, resumes the march in column, faces to the rear, marches to the rear, and changes direction on the march* by the same commands as when at full distance.

Being in Column of Masses, to Change Direction by the Flank.

418. 1. *Change direction by the right (or left) flank,*
2. MARCH.

The first battalion changes direction by the right flank (Par. 344); each of the other battalions wheels by fours to the right, and is marched with the guide to the left, by two partial changes of direction to the left, to its position in the new column, wheeled by fours to the left, and halted. The partial changes of direction are executed in double time.

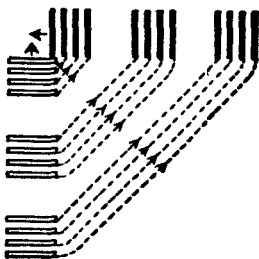

Pl. 78, Par. 418.

TO DEPLOY THE COLUMN OF MASSES.

Being in Column of Masses, to Deploy to the Right or Left.

419. 1. *Deploy column,* 2. *Fours right (or left),* 3. MARCH.

The first battalion deploys to the right (Par. 346); the second is marched in close column to its position on the line to the right of the first and then deployed in the same manner as the first; the third, in a similar manner, is deployed on the right of the second.

The second and third battalions may be marched in column of fours (Par. 342) to their places on the line.

To deploy faced to the rear, the colonel adds: *Faced to the rear, after deploy column.*

420. To form line on the rear of the column, facing either to the front or to the rear, the colonel first faces the column to the rear, and then executes the movement as explained.

Being in Column of Masses, to Deploy to the Right and Left,

421. 1. *Deploy column*, 2. *Fours right and left*, 3. MARCH.

The first battalion deploys to the right; the second and third deploy on the line; the second to the left of the first; the third to the left of the second.

If the colonel commands: 2. *Fours left and right*, the first battalion deploys to the left; the others deploy on the line, the second on the right of the first; the third on the right of the second.

Being in Column of Masses, to Deploy in Two Lines.

422. 1. *In two lines*, 2. *Deploy column*, 3. *Third* (or such) *battalion, second line*, 4. *Fours right* (or left), 5. MARCH.

The first battalion deploys to the right; the second deploys on the line of the first and to its right; the third moves in column of fours and forms line in rear of the center of the first line.

If the colonel commands: 4. *Fours right and left*, the

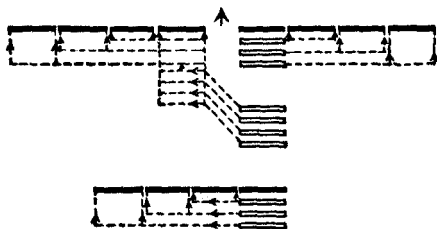

Pl. 79, Par. 422.

first battalion deploys to the right; the second (Pl. 79) deploys on the line of the first and to its left; the third deploys to the left.

If the colonel commands: 4. *Fours left and right*, the first bat-

talion deploys to the left; the second deploys on the line of the first and to its right; the third deploys to the right.

Being in Column of Masses, to Deploy in Three Lines.

423. 1. *Battalions*, 2. *Deploy column*, 3. *Fours right (or left)*, 4. MARCH.

Being in Column of Masses, to March to the Right or Left in Line of Battalions in Columns of Fours.

424. 1. *Battalions*, 2. *Columns of fours*, 3. (Such) *company*, 4. *Fours right (or left)*, 5. MARCH, 6. (Such) *the base battalion*.

Column of Battalions.

425. Being in line, or column of fours, the regiment ploys into column of battalions by approximating the principles for forming close column, School of the Battalion; except that the leading battalion halts upon forming line.

Being in Line, to Ploy into Column of Battalions.

426. 1. *Column of battalions*, 2. *On first (or third) battalion*, 3. *Fours right (or left)*, 4. MARCH.

The first battalion stands fast. The second executes *fours right, column right*, marches the normal or specified distance (Par. 385) to the rear, changes direction to the left, and forms line to the left, in rear of and parallel to the first battalion. The third battalion executes *fours right, column half right*, and forms in rear of the second, as explained for the second.

Being in Line, to Ploy into Column of Battalion on Second Battalion.

427. 1. *Column of battalions*, 2. *On second battalion*, 3. *Fours left and right*, 4 MARCH.

The second battalion stands fast; the first battalion executes *fours left* and forms line in rear of the second; the third battalion executes *fours right* and forms line in rear of the first; right guides cover.

Being in Column of Fours, to Form Column of Battalions Faced to the Right or Left.

428. 1. *Column of battalions*, 2. *First battalion*, 3. *Fours right* (or left), 4. MARCH.

The first battalion forms line and is halted; the others incline to the left, and each enters the column parallel to and at the prescribed distance from the one preceding, forms line as prescribed for the first; right guides cover.

Being in Column of Fours, to Form Column of Battalions Faced to the Rear.

429. 1. *Column of battalions, faced to the rear*, 2. *First battalion*, 3. *Column right* (or left), 4. MARCH.

The first battalion changes direction to the right and when its rear has cleared the flank of the column by twelve paces, forms line to the right and halts.

The battalions in rear move forward and each, when it has passed battalion distance and twenty-four paces beyond the preceding battalion, changes direction to the right, forms line, and halts, as prescribed for the first; right guides cover.

Being in Column of Battalions, to Form Front into Line.

430. 1. *Right* (or left) *front into line*, 2. MARCH.

The first battalion stands fast; the second forms line on the right of the first and the third on the right of the second.

The colonel may direct the major of the third battalion to form it on the left (or right) of the first (Pl. 80).

431. To form line faced to the rear, the colonel adds *faced to the rear* to the first command. The first battalion is faced to the rear; the rear battalions form on the line faced to the rear.

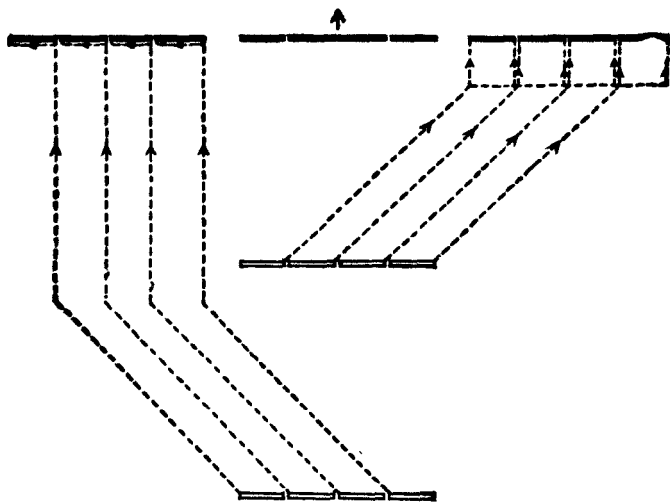

Pl. 80, Par. 430.

Line of Masses.

432. Each major takes post twelve paces in front of the center of his first company.

In all formations into line of masses, whether by a simultaneous or successive movement, the adjutant or sergeant major of each battalion posts the guides of its leading company.

Being in line of Masses to Extend or Close Intervals.

433. To extend intervals: 1. *On (such) battalion,*
2. *Take deploying intervals,* 3. **MARCH.**

The designated battalion stands fast; the other battalions march by the flank, inclining slightly to the rear,

and when they have gained the interval, execute *fours right* (or *left*) and are halted on the line.

Intervals are closed on the same principles: 1. *On* (such) *battalion*, 2. *Close intervals*. 3. **MARCH.**

Being in Line, to Form Line of Masses on the First or Third Battalion.

434. 1. *Line of masses, on first company, first battalion*, 2. **MARCH.**

The first battalion ploys on its first company (Par. 338); the second and third battalions move by the right and each ploys (Par. 341) with twenty-four paces interval from the left of the preceding battalion.

Line of masses on the fourth company, third battalion, is formed according to the same principles.

435. Line of masses may be formed on an interior battalion, the colonel designating the first or fourth company.



Pl. 81, Par. 435.

The designated battalion ploys on the designated company; the other battalions ploy on the company nearest the point of rest, first closing, if not at the proper interval.

Being in Column of Fours, to Form Line of Masses, Faced to the Right or Left.

436. 1. *To the right* (or *left*) *into line of masses*, 2. **MARCH.**

The first battalion ploys faced to the right (Par. 341); the others execute the same movement, each major commanding *march* when the head of his column is twenty-eight paces from the flank of the preceding company.

Being in Column of Fours, to Form on Right or Left into Line of Masses.

437. 1. *On right (or left) into line of masses*, 2. MARCH.

The major of the first battalion commands: 1. *Column right*. The first battalion having advanced forty paces in the new direction, the major commands: 1. *Close column*, 2. *First company*, 3. *Column left*, 4. MARCH (Par. 339); each of the others passes beyond the preceding battalion and executes the same movements as explained for the first, so as to have the interval of twenty-four paces from the battalion on its right.

Being in Column of Fours, to Form Front into Line of Masses.

438. 1. *Right (or left) front into line of masses*, 2. MARCH.

At the first command, the major of the first battalion commands: 1. *Close column*, 2. *First company*, 3. *Column right*, and the other majors command: 1. *Column half right*.

At the command *march*, the first battalion ploys faced to the front (Par. 339); each of the others is marched to the right front and executes the same movement, so as to have the interval of twenty-four paces between it and the one next on its left.

Right and left (or left and right) front into line of masses is executed on the same principles.

The first battalion ploys into close column, as in executing *right front into line of masses*; the second and third battalions ploy as in executing *left front into line of masses*: Pl. 82, Par. 437.

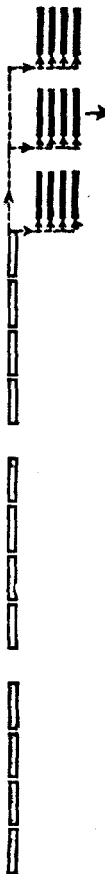

the second on the left of the first and the third on the left of the second.

Being in Column of Fours, to Form Front into Line of Masses, Faced to the Rear.

439. 1. *Right (or left) front into line of masses, faced to the rear,* 2. MARCH.

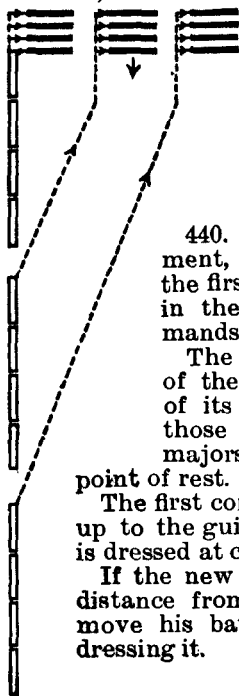

The first battalion plays faced to the rear (Par. 340); each of the other battalions is marched to the right front and executes the same movement so as to have the interval of twenty-four paces to the left of the battalion on its right.

To Align the Line of Masses.

440. If necessary to rectify the alignment, the colonel assures the guides of the first company of one of the battalions in the desired direction and then commands: *Guides on the line.*

The adjutant or sergeant major of each of the other battalions posts the guides of its leading company on the line of those established by the colonel; the majors dress their battalions toward the point of rest.

The first company of each battalion is dressed up to the guides; each of the other companies is dressed at close distance.

If the new line be established at considerable distance from the battalions, each major will move his battalion to its new position before dressing it.

Movements of Masses.

Pl. 83, Par. 439. 441. The line of masses *advances, halts,*

faces to the rear, and marches to the rear by the same commands and means as the regiment in line.

Being in Line of Masses, to Change Front.

442. Being in march : 1. *Change front on first (or third) battalion*, 2. MARCH.

The major of the first battalion adds: *Column right*.

At the command *march*, the first battalion changes direction to the right, and when the first company has advanced forty paces in the new direction the major halts the battalion ; the other battalions change direction half right and are so marched that by another change of direction half right each may arrive on the line abreast of and twenty-four paces to the left of the preceding battalion.

Being in Line of Masses, to March by the Flank.

443. 1. *Fours right (or left)*, 2. MARCH, 3. *Guide (right or left)*.

The battalions preserve the distance of twenty-four paces.

The Line of Masses, Marching by the Flank in Quick Time, to Change Direction.

444. 1. *Change direction to the right (or left)*, 2. MARCH.

The leading battalion changes direction to the right in double time (Par. 323); the others, at the commands of their majors, change direction similarly, on the same ground as the first.

The Line of Masses, Marching by the Flank, to Form Line of Masses to the Right or Left.

445. 1. *Fours right (or left)*, 2. MARCH, 3. *Battalions*
4. HALT ; or, 3. (Such) *the base battalion*.

Being in Line of Masses, to Form Column of Fours.

446. Being at a halt: 1. *Column of fours*, 2. *First company, first (or third) battalion*, 3. *Right (or left) forward*, 4. *Fours right (or left)*, 5. MARCH.

The first battalion executes the movement; each of the others successively executes the movement and inclines to the right or left, so as to follow the battalion preceding at the prescribed distance.

Or, the colonel may command: 1. *Column of fours*, 2. *First (or fourth) company, first battalion*, 3. *Fours right*; or, 2. *First (or fourth) company, third battalion*, 3. *Fours left*, 4. MARCH.

The battalion designated executes the movement; each of the others successively executes the movement in time to follow the battalion preceding at the prescribed distance.

Being in Line of Masses, to Form Column of Masses to the Right or Left.

447. 1. *Battalions*, 2. *Change direction by the left (or right) flank*, 3. MARCH.

Each battalion changes direction by the left flank (Par. 344).

Being in Line of Masses, to Form Column of Masses, Faced to the Front.

448. 1. *Column of masses on first (or such) battalion*, 2. MARCH.

The first battalion stands fast or is halted; the second is placed in close column, **in rear of the first, and the third in rear of the second.**

If the third battalion be designated, the second takes position in rear of the third, the first in rear of the second.

If the second battalion be designated, the first takes

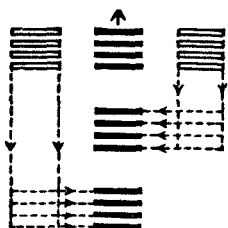

Pl. 84, Par. 448.

position in rear of the second (Pl. 84), and the third in rear of the first.

Each major may maneuver his battalion into position in mass or in column of fours. The adjutant or sergeant major of each battalion moves in advance, to indicate the point where his battalion moves by the flank or changes direction to enter the column.

449. Being in line of masses, to form the column of masses facing to the rear, the colonel first causes the battalions to wheel about by fours, and then gives the same commands as before.

Being in Column of Masses, to Form Line of Masses to the Right or Left.

450. The colonel causes the battalions to change direction by the left or right flank (Par. 344); or commands: 1. *Forward*, 2. *Battalions*, 3. *Column right (or left)*, 4. **MARCH**, 5. *Battalions*, 6. **HALT**; or, 5. (Such) *the base battalion*.

Being in Column of Masses, to Form on Right or Left into Line of Masses.

451. Being in march: 1. *On right (or left) into line of masses*, 2. **MARCH**.

The major of the first battalion commands: 1. *Column right*, 2. *Double time*.

At the command *march*, the first battalion changes direction to the right; it is halted when the first company has advanced forty paces in the new direction; each of the others marches twenty-four paces beyond the preceding one, changes direction to the right, in double time, is halted, and established abreast of the first battalion.

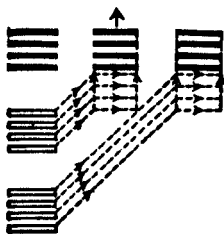
Being in Column of Masses, to Form Front into Line of Masses.

Pl 85, Par. 452.

452. 1. *Right (or left) front into line of masses, 2. MARCH.*

The first battalion stands fast or is halted; the second and third battalions are moved in masses to their places, the second on the right of the first, the third on the right of the second.

The colonel may direct the major of the third battalion to form on the left (or right) of the first.

Being in Line, to Change Front.

453. To change front on a flank battalion, the colonel forms column of fours to the right or left and then executes *front into line* or *front into line, faced to the rear* (Pars. 390 and 391).

To change front on an interior battalion, the colonel forms column of fours to the right or left, and then executes *front into line* on the head of the designated battalion (Par. 393).

Movements by Platoons.

454. The interval between battalions in line of platoon columns is platoon front and twenty-four paces

455. All movements in column of platoons and line of platoon columns, School of the Battalion, may be executed by the regiment by similar commands and means; the colonel designates (Such) *battalion* when necessary.

456. In forming line, or line of platoon columns, each major first moves his battalion into position on the principles for forming line from column of fours, and at the proper time gives the commands for forming line, or line of platoon columns.

Order in Echelon.

457. Being in line at a halt, to advance in echelon:
 1. *Form echelon at (so many) yards,* 2. (Such) *the base battalion,* 3. MARCH.



Pl. 86. Par. 457.

At the second command the major of the designated battalion commands: 1. *Forward,* 2. *Guide center;* the other majors caution: *Stand fast.*



Pl. 87, Par. 457.

At the command *march*, the designated battalion advances; the others take up the march, each when it has the specified distance from the one next preceding.

A file closer from each rear battalion marches at the specified distance directly in rear of the guide on the nearest flank of the preceding battalion. Each rear battalion marches abreast of and preserves the interval of twenty-four paces from the file closer thus posted.

458. The regiment in echelon *advances, halts, obliques, marches to the rear or by the flank* by the same commands as when in line.

Being in Echelon of Battalions, to Form Line.

459. 1. *Form line on* (such) *battalion*, 2. MARCH.

The designated battalion halts or stands fast; the others form on the line of the one designated by moving to the front or rear.

A general alignment is given if necessary.

THE BRIGADE.

460. The brigade consists of three regiments, but the rules prescribed are applicable to a less or greater number; it is commanded by a brigadier-general.

461. Regiments in line are designated *right, center, and left*; or, if one be in rear, *right, left, and rear*; in column they are designated *leading, center, and rear*.

Unless otherwise directed by the general, the regiments are posted according to the rank of the colonels: in line, from right to left, the senior on the right; in two or three lines by regiments, the senior in the first line, the junior in the rear line; in column, from head to rear, the senior at the head.

462. The interval between regiments is forty-eight paces.

463. In line, the general takes post one hundred paces in front of the center of the brigade; in column, at the head of the brigade.

The general is attended by the adjutant-general, riding on his left, his aids six paces in rear. When the remaining officers of his staff are present, they ride on the left or in rear of the aids, according as they form one or more ranks, senior on the right; the orderlies three paces in rear of the staff.

464. The drill exercises should be limited to movements used in campaign.

The regulations for the evolutions of the regiment are applicable to the brigade.

In moving into position, the regiments and battalions are habitually marched in column of fours and by the shortest practicable route.

465. When the orders of the general to a regimental commander are communicated through staff officers,

the name of the regimental commander or the permanent designation of the regiment will be mentioned.

These orders should be explicit and should cover the following points :

First. The maneuver to be executed by the brigade.

Second. The particular formation the regiment is to take ; as, *in two lines, line of masses*, etc. When the formation is not specified, the regiment forms in line.

Third. When forming the brigade in two or more lines by regiment, the number of lines, the distance between the lines, the line in which the regiment is to form, and its point of rest.

When necessary, staff officers are sent to indicate the point of rest for each line.

Fourth. Whether the right or left of the regiment is to connect with the left or right of another regiment that precedes it on the line.

Fifth. Whether the right or left flank of the regiment will be exposed.

Being in Column of Fours, to Form Front into Line.

466. The general sends orders as follows :

To each colonel : *The brigade to form front into line ;*
to the leading regiment : *Form right front into line ;*
to the center regiment : *Form left front into line, your right connecting with left of leading regiment ;*
to the rear regiment : *Form right front into line, your left connecting with right of leading regiment, right flank exposed.*

The colonel of the leading regiment forms it right front into line ; the colonel of the center regiment marches it forward to the line, to the left of the leading regiment, so as to have an interval of forty-eight paces, and forms it left front into line ; the colonel of the rear regiment marches it forward to the line, to the right of the leading regiment, and forms it right front into line.

On the same principles the regiments may be formed front into line, in any order.

Being in Column of Fours, to Form Line to the Right or Left.

467. The general sends orders : *Form line to the right (or left).*

The colonels command : 1. *Fours right (or left)*, 2. MARCH, 3. *Battalions*, 4. HALT.

468. To form in two or three lines, the general sends orders : *Form in two (or three) lines to the right (or left)*, or adds : *At (so many) paces distance.*

The colonel of the leading regiment forms his regiment in two lines to the right and halts it ; the colonels of the rear regiments give the commands for forming in two lines, each when his first battalion has closed to forty-eight paces from the right flank of the first line of the regiment preceding.

469. Being in column of fours, *on right or left into line*, is executed on similar principles, each regiment passing beyond the one preceding.

When regiments are formed in two or three lines, the first line advances far enough to allow the second or third line to clear the line of march.

470. Being in column of platoons, line is formed *to the right or left, to the front and on right or left*, according to the same principles.

According to the same principles, the brigade may be formed in one, two, or three lines of *platoon columns*, lines of *masses* or lines of *columns of fours* ; or one or two regiments may be given a designated formation.

To March in Line.

471. The general sends orders : *Advance in line* (or such formation), (such) *battalion*, (such) *regiment*, *the base battalion*.

The orders having been communicated, and the proper

dispositions having been made in each regiment, the general causes the *forward* to be sounded.

When in two or three lines, the second and third lines preserve their positions relative to the first line.

To Halt.

472. The general causes the *halt* to be sounded, which is repeated and each regiment is halted.

To March to the Rear.

473. The general sends orders: *March to the rear, (such) battalion, (such) regiment, the base battalion.*

Each colonel causes his regiment to face to the rear and gives the preparatory commands to march in line.

The general causes the *forward* to be sounded.

The brigade being in two lines, the base battalion will be in the late second line, now the first. The designation of the battalion and regiment refers to its position in line when marching to the rear.

474. The line of platoon columns, line of masses, or line of columns of fours marches according to the same principles as when in line.

To March by the Flank.

475. Being in line or line of columns, the general sends orders: *March by the right (or left) flank.*

Each colonel commands: 1. *Fours right*, 2. **MARCH**, 3. *Battalions*, 4. **HALT**. The general then causes the *forward* to be sounded.

When in more than one line, the lines retain their former designations; the first battalion of the first line is the base battalion; the other line or lines maintain the same relative positions as at the beginning of the movement.

476. To re-form the line when in line of platoon

columns, line of masses, or line of columns of fours, the general sends orders : *Re-form line*.

Each colonel forms line.

477. When at close interval, the general sends orders: *Re-form line* (such) *battalion*, (such) *regiment*, *the base battalion*.

The colonel of the designated regiment causes it to take deploying intervals and form line; the other colonels cause their regiments to move by the flank until opposite their positions, take deploying intervals, and form line.

Change of Front.

478. Changes of front are usually executed by forming in column of fours and then forming front into line, or front into line faced to the rear.

If in two or three lines, the simplest means are used for moving the second and third lines to their new positions.

THE DIVISION.

479. The division consists of three brigades of infantry and two or more batteries of artillery, but the rules prescribed are applicable to a less or greater number; it is commanded by a major-general.

The principles prescribed for the evolutions of the brigade apply to the division.

480. In line, the division commander takes post one hundred and fifty paces in front of the center of the division; in column, at the head of the division.

481. The brigades are designated, in line, *right*, *centre*, and *left*; or, if one be in rear, *right*, *left*, and *rear*; in column, *leading*, *center* and *rear*.

Unless otherwise directed by the division commander, the brigades are posted according to the rank of brigade commanders in the manner prescribed for posting regiments in brigade.

482. The division is formed in one, two, or three lines, by brigade, and each brigade is given one of the formations prescribed in brigade drill.

The interval between brigades is seventy-two paces, which is increased when interval is left for artillery.

483. The orders of the division commander are communicated through staff officers; the orders should cover the following points: The particular formation for each brigade and its point of rest; the direction in which the line is to extend; the distance between lines and the point of rest for each line; the name of the brigade commander or the permanent number of the brigade will be mentioned.

THE CORPS.

484. The corps consists of three divisions, one or more regiments of cavalry, and the *corps artillery*, which is in addition to the *divisional artillery*.

The principles prescribed for the evolutions of the division apply to the corps or a larger command.

SALUTE WITH THE HAND.

485. The salute for officers is the same as in Par. 29, the left hand is used only when the right is engaged. Officers and men, when saluting, look toward the person saluted. Enlisted men salute with the hand farthest from the officer, giving the salute six paces before passing the officer and holding the hand at the visor until the salute is acknowledged or the officer passed.

The rifle salute (Par. 95) is made six paces before passing the officer, holding the hand at the shoulder until the salute is acknowledged or the officer passed.

Courtesy among military men is indispensable to discipline; respect to superiors will not be confined to obedience on duty, but will be extended on all occasions.

ABOUT FACE FOR OFFICERS.

486. At the command *about*, carry the toe of the right foot about eight inches to the rear and three inches to the left of the left heel, without changing the position of the left foot.

At the command *face*, turn upon the left heel and right toe, face to the rear, and replace the right heel by the side of the left.

Enlisted men out of ranks may use the about face prescribed for officers.

MANUAL OF THE SWORD.

487. 1. *Draw*, 2. SWORD.

At the command *draw*, unhook the sword with the thumb and first two fingers of the left hand, thumb on the end of the hook, fingers lifting the upper ring; grasp the scabbard with the left hand at the upper

band, bring the hilt a little forward, seize the gripe with the right hand, and draw the blade six inches out of the scabbard, pressing the scabbard against the thigh with the left hand.

At the command *sword*, draw the sword quickly, raising the arm to its full extent, at an angle of about forty-five degrees, the sword, edge down, in a straight line with the arm, and make a slight pause; hook up the scabbard with the thumb and first two fingers of the left hand, thumb through the upper ring, fingers supporting it, and drop the left hand by the side; at the same time drop the right hand to the side and bring the back of the blade in a vertical position against the shoulder, back of the gripe to the rear, the arm extended without constraint, the thumb and forefinger embracing the gripe, the left side of the gripe with the thumb against the thigh, the other fingers extended and joined in rear of the gripe. *This is the position of carry sword.*

Officers mounted unhook the sword before mounting, and, in the first motion of *draw sword*, reach with the right hand over the bridle hand, and without the aid of the bridle hand draw the sword as before; the right hand at the *carry* rests on the right thigh.

488. When publishing orders, the sword is held suspended from the right wrist by the sword knot; when the sword knot is used, it is placed on the wrist before drawing sword, and taken off after returning sword.

489. 1. *Present*, 2. **SWORD (OR ARMS).**

At the command *present*, carry the sword to the front, base of the hilt as high as the chin and six inches in front of the neck,



Pl. 88, Par. 489.

edge to the left, point six inches further to the front than the hilt, thumb extended on the left of the gripe, all the fingers grasping the gripe.

At the command *sword*, lower the sword, point to the front and near the ground, edge to the left, hand by the side, thumb on left of gripe, arm extended.

1. *Carry*, 2. **SWORD** (or **ARMS**).

Resume the carry.

In rendering honors with troops, officers execute the first motion of the salute at the command *present*, the second motion at the command *arms*; en-

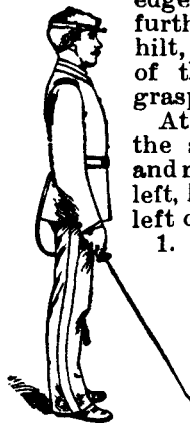

Pl. 89, Par. 489.

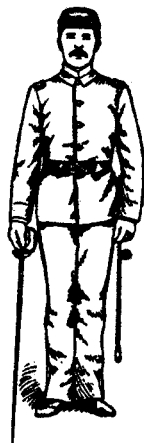

Pl. 90, Par. 489.

listed men with the the first motion at the sword is returned to command: 1. *Carry*, 490. 1. *Order*, 2.

Drop the point of front, point on or down, thumb on back

At the command: (or **ARMS**), resume

491. When arms der, the officers and sword drawn execute

492. The sword is while marching at position; swords are when arms are or **right shoulder**.

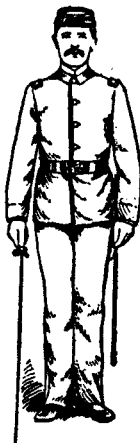

Pl. 91, Par. 490.

sword drawn execute command *arms*. The the carry at the 2. **ARMS**.

SWORD (or **ARMS**).

the sword to the near the ground, edge of the gripe.

1. *Carry*, 2. **SWORD** the carry.

are brought to the or-enlisted men with the *order sword*.

held at the carry attention or changing brought to the carry brought to the carry

493. 1. *Parade*, 2. **REST.**

Being at the order, clasp the hands in front of the center of the body, left hand uppermost, point of sword on or near the ground in front of the center of the body, edge to the right.

At the command *attention* resume the order.

494. In marching in double time the sword is carried diagonally across the breast, edge to the front ; the left hand steadies the scabbard.

495. Officers on all duties under arms draw and return sword without waiting for any command. All commands to soldiers under arms are given with the sword drawn.

496. 1. *Return*, 2. **SWORD.**

At the command *return*, carry the right hand opposite to and six inches from the left shoulder, sword vertical, edge to the left ; at the same time unhook and lower the scabbard with the left hand, and grasp it at the upper band.

At the command *sword*, lower the blade and pass it across and along the left arm, point to the rear ; turn the head slightly to the left, fixing the eyes on the opening of the scabbard, and return the blade ; free the wrist from the sword knot (if inserted in it), turn the head to the front, and drop the right hand by the side ; at the same time hook up the sword with the left hand, and drop the left hand by the side.

Officers mounted return sword without using the left hand ; the sword is hooked up on dismounting.

497. At inspection, enlisted men with the sword drawn execute the first motion of *present sword*, and turn the wrist to show both sides of the blade, resuming the carry when the inspector has passed.

THE COLOR.

Manual of the Color.

498. At a *carry*, the heel of the pike rests in the socket of the sling at the right hip; the right hand grasps the pike at the height of the shoulder.

At the *order*, the heel of the pike rests on the ground near the right toe, the right hand holding the pike in a vertical position.

At *parade rest*, the heel of the pike is on the ground, as at the order; the pike is held with both hands in front of the center of the body, left hand uppermost.

The *order* is resumed at the command *attention*.

The left hand assists the right when necessary.

The carry is the habitual position when the troops are at a carry, right shoulder, or trail.

The carry, order, and parade rest are executed with the troops.

The color salute. Being at the carry, slip the right hand up the pike to the height of the eye, then lower the pike by straightening the arm to the front.

The color salutes in the ceremony *Escort of the Color*, and when saluting an officer entitled to the honor, as prescribed in Pars. 422 to 427, Army Regulations, 1889, but in no other case.

If marching, the salute is executed when at six paces from the officer entitled to the salute; the carry is resumed when six paces beyond him.

At a halt, the salute is executed at the command *present arms*, the carry is resumed at the command *carry arms*.

Color Guard.

499. In each regiment there is a color guard, com-

posed of one sergeant, who is the color bearer, and two experienced soldiers selected by the colonel.

The color is with the battalion designated by the colonel, usually the second, or the first if there be but two battalions.

When the regimental color is paraded it is carried by a sergeant selected by the colonel; he takes his place on the left of the color bearer and conforms to his movements, remaining on his left, except when in column of fours with the file closers on the left flank, in which case the regimental color is on the right.

The color, kept at the office or quarters of the colonel, is escorted by the color guard, marching in one rank, the color bearer in the center, to the color company on its parade ground; and in like manner back to its place of deposit.

The color guard, at the command of the color bearer, presents arms on receiving and on parting with the color; in the latter case, the color guard returns to the carry at the command of the senior member of the guard.

THE BAND.

500. The band is formed in two or more ranks, with sufficient intervals between the men and distances between the ranks to permit a free use of the instruments.

The field music, when united, forms with and in rear of the band; when the band is not present, the posts, movements, and duties of the field music are the same as prescribed for the band; when a musician is in charge, his post is on the right of the front rank. When the battalion or regiment wheels about by fours, the band executes the counter-march; when the battalion or regiment executes *right, left* or *about face*, the band faces in the same manner.

In marching, the different ranks dress to the right.

In executing *open ranks*, each rank of the band takes the distance of three paces from the rank next in front; the drum major verifies the alignment.

The field music sounds the *march, flourishes*, or *ruffles*, and *to the color* at the signal of the drum major.

Instructions for the Drum Major.

501. The drum major is two paces in front of the center of the front rank, and gives the signals or commands for the movements of the band as for a squad, substituting in the commands *band* for *squad*.

The staff is held in the right hand, hand below the chin, back to the front, head of the staff near the hand, ferrule pointing upward and to the right. After each signal the staff is restored to this position.

Signals of the Drum Major.

To play—Face toward the band and extend the right arm to its full length in the direction of the staff.

To cease playing—Extend the right arm to its full length in the direction of the staff.

To march—Turn the wrist and bring the staff to the front, the ferrule pointing upward and to the front; extend the arm to its full length in the direction of the staff.

To halt—Reverse the staff and hold it horizontally above the head with both hands, the arms extended; lower the staff with both hands to a horizontal position at the height of the hips.

To counter-march—Face toward the band and give the signal *to march*. The counter-march is executed by each front rank man to the right of the drum major turning right about, each to the left turning left about. each followed by the men covering him. The drum major passes through the center.

To oblique—Bring the staff to a horizontal position, the head of the staff opposite the neck, the ferrule pointing in the direction the oblique is to be made; extend the arm to its full length in the direction of the staff.

To march by the right flank—Extend the arm to the right, the staff vertical, ferrule upward, back of the hand to the rear.

To march by the left flank—Extend the arm to the left, the staff vertical, ferrule upward, back of the hand to the front.

To diminish front—Let the ferrule fall into the left hand at the height of the eyes, right hand at the height of the hip.

To increase front—Let the ferrule fall into the left hand at the height of the hip, right hand at the height of the neck.

The march, flourishes, or ruffles—Bring the staff to a vertical position, hand opposite the neck, back of the hand to the front, ferrule pointing upward.

The assembly—Bring the staff to a horizontal position,

hand opposite the neck, back of the hand down, ferrule pointing to the left.

To the color—Bring the staff to a horizontal position at the height of the neck, back of the hand to the rear, ferrule pointing to the left.

In marching, the drum major beats the time with his staff and supports the left hand at the hip, fingers in front, thumb to the rear.

The drum major, before making his report at parade, salutes by bringing his staff to a vertical position, head of the staff up and opposite the left shoulder.

The drum major, marching in review, passes the staff between the right arm and the body, head of the staff to the front, and then salutes with the left hand.

EXTENDED ORDER.

GENERAL PRINCIPLES.

502. The squad is the basis of extended order.

Men will be taught to regard the squad as the unit from which they ought never to be separated; but if the squad should be broken up or the men become separated, they place themselves under the orders of the nearest leader and remain with his squad as if it were the one to which they originally belonged.

Officers and sergeants will give their attention to preserving the integrity of the squads; they appoint new leaders to replace those disabled, organize new squads when necessary, and see that every man is placed in a squad.

503. This instruction, on account of its importance, will be given as soon as the recruits have had a few drills in close order. The mechanism of the movements is taught on the drill ground (Pars. 115 and 116), with every attention to detail; afterward the movements are executed on varied ground, making use of the accidents of the surface for cover, etc., and observing the conditions of battle.

504. In all instruction in extended order, the movement must be made with reference to an enemy supposed to be in an indicated direction.

505. The enemy is said to be *imaginary* when his position and force are merely assumed; *outlined* when his position and force are indicated by a few men only; and *represented* when a body of troops acting as such has his supposed force and position.

506. Men in extended order fix their attention at the first word of command, the first note of the trumpet or

the first motion of the signal; the movement commences immediately upon the completion of the command, trumpet call, or signal.

507. Extended order may be taken from any formation.

508. Upon arriving on the line and upon halting, men in extended order face to the front, whether in squads or as individual skirmishers.

509. No commands for dressing are given in extended order; the general alignment is taken toward the base file; the men stand and march at ease (see Par. 246) and pay close attention.

510. When necessary for any chief to leave his post, he will return to it as soon as possible.

Leading the Squad.

511. In the exercise in leading, the movements are executed at signals from the corporal, and as far as possible without commands or cautions; the object being to prepare the squad for the battle exercises by training the men to cooperate with their leader and conform instantly to his wishes.

512. The movements are executed in the most direct manner, first in quick time, then in double time, and finally at a run; they should not succeed each other so rapidly as to produce confusion.

513. The corporal is posted three paces in front of the squad, which conforms to his signals and movements.

514. The squad is exercised in turning, marching to the front, rear, and by the flank, obliquing, halting, assembling, etc.

515. The man in front of whom the corporal places himself is the guide of the squad, and follows in the trace of the corporal at a distance of three paces.

516. When the corporal does not wish the squad to follow him, he commands: *Guide (right or left)*, and

indicates the point of direction; if marching by the flank, he indicates the direction.

517. When the squad is marched to the rear, the corporal takes position in front of the squad.

THE SQUAD.

General Rules.

518. The squad is deployed *forward* when it is in rear of the line to be occupied, and *by the flank* when it is already on that line. If the squad be at a halt, it is placed in march before deploying forward. If the squad be in march, it is halted before deploying by the flank.

519. The normal interval between skirmishers is two paces; when a greater or less interval is used it will be stated in the preparatory command.

520. Before giving the commands for marching, deploying, or assembling, or for increasing or diminishing intervals, the corporal indicates the file which is to be the base or guide, places himself three paces in front of it, and indicates the direction.

On halting, the corporal places himself three paces in rear of his squad.

521. The deployment as skirmishers is made on the front rank man of the second file from the right (No. 2).

The rear rank men place themselves on the alignment to the right of their file leaders, each, as soon as there is interval.

522. If the squad is to kneel or lie down upon halting, the corporal gives the cautionary command *kneel* (or *lie down*) upon halting, before giving the commands for deploying. The squad will then kneel (or lie down) at each halt until otherwise directed.

To Deploy as Skirmishers.

523. Forward:

Marching in line: 1. *As skirmishers*, 2. **MARCH.**

The front rank man, second file (Par. 521) moves straight to the front or in the direction indicated by the corporal.

The other men oblique to the right or left according as they are on the right or left of the second file, increasing the cadence, each resuming the direction and cadence of the guide when at his interval (Par. 519) and on the alignment. The rear rank men follow or precede their file leaders on the line according as they gain intervals to the right or left.

When the squad arrives upon the line to be occupied, the corporal halts it by the commands: 1. *Squad*, 2. HALT.

524. By the flank:

Being in line at a halt: 1. *As skirmishers*, 2. MARCH.

The base (Par. 521) stands fast; the other men move rapidly to the right or left, according as they are on his right or left, each man halting on the line when he has gained his interval.

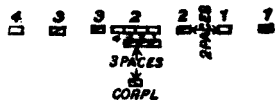

Pl. 92, Par. 524.

To Increase and Diminish Intervals.

525. Being deployed as skirmishers, to increase or diminish intervals: 1. *To* (so many) *paces*, *extend* (or *close*), 2. MARCH.

The skirmishers open from or close toward the guide.

If marching, the movement is executed by obliquing and increasing the cadence; if at a halt, the movement is executed by the flank.

Marchings.

526. Being deployed and halted, to move forward: 1. *Forward*, 2. MARCH.

The skirmishers take the direction and keep their intervals from the side toward the guide.

527. Being deployed, at a halt or advancing, to march to the rear: 1. *To the rear*, 2. MARCH.

The men face about and march to the rear, conforming to the principles of the march to the front. The corporal moves quickly in front of the guide.

To march again to the front : 1. *Forward*, 2. MARCH.
528. To march by the flank : 1. *By the right* (or *left*) flank, 2. MARCH.

At the command *march*, each man faces to the right and follows the man in his front. The corporal moves quickly beside the leading man to conduct him (see Par. 516).

To march again in line : 1. *By the left* (or *right*) flank, 2. MARCH.

529. The squad being in march, to the front, rear, or by the flank, is halted by the commands : 1. *Squad*, 2. HALT.

530. The squad being deployed, to change front or direction, the corporal indicates the direction and commands : 1. *Squad right* (or *left*), 2. MARCH ; or, 1. *Right* (or *left*) turn, 2. MARCH, according as the squad is to halt or advance ; executed as in Pars. 140 and 141, the skirmishers maintaining their intervals.

To Rally.

531. The rally is used for immediate and concentrated action when there is not time to form in the normal order. The rally should be made either on the line or in advance of it.

The corporal signals or commands : RALLY.

The men run toward the corporal and group themselves in single or double rank, in line, in circle, in semi-circle, or in such other formation as he directs, and fix bayonet.

If the corporal continues to advance, the men form in rear of him in single or double rank as he directs. and follow him, fixing bayonet.

The squad being rallied may advance or deploy (Pars.

523 and 524); in deploying, the skirmishers return to their former places.

The Assembly.

532. Being deployed or rallied, the corporal signals or commands: 1. *Assemble*, 2. **MARCH**.

The men move toward the corporal and form in their proper places.

If the corporal continues to advance, the men move in double time, form, and follow him.

Assembling when faced or marching to the rear will not be executed.

533. When the preceding movements are well understood, they are executed at signals.

FIRE DISCIPLINE.

534. The instructor will impress upon the men the importance of the following:

General Rules.

1. Never load until the moment for firing.
2. Never fire except when ordered, and then only the number of cartridges indicated.
3. Never fire after the command or signal *Cease firing*.
4. Never fire except at the named objective.
5. Never fail to adjust the sight at the range named.
6. Always aim at the feet of the enemy, or, if he is hidden from view, at the lower line of smoke.

535. Notwithstanding these rules, it is allowable, especially for scouts, to fire when necessary—

- a. To give the alarm.
- b. When a good opportunity occurs to fire upon a leader of the enemy.
- c. In self defense.

536. Individual men who may be acting beyond the immediate control of leaders will observe the following :

They will not fire at distances over—

400 yards at a man lying down.

500 yards at a man kneeling.

600 yards at a man standing.

700 yards at a horseman.

800 yards at a small squad of men or a line of skirmishers.

Sharpshooters may, when permitted by an officer, fire upon the enemy at greater distances.

537. Volleys by squads are used against troops in close order at distances not exceeding—

800 yards at a line equal to the front of a squad.

1,000 yards at a line equal to the front of a platoon.

1,200 yards at a line equal to the front of a company.

These limits are not invariable; they may be exceeded under favorable conditions when the range is accurately known, but should always be reduced when the men are tired or out of breath, the range uncertain, the enemy under cover, or the conditions of wind and light unfavorable.

When the supply of ammunition is ample and the enemy is in large bodies, volleys may be fired at extreme ranges.

538. The fire at will and the fire with counted cartridges are used at distances ranging from 800 to 400 yards.

539. The rapid fire is used at short ranges at the decisive moment of the action.

540. The ranges are classified as follows :

0 to 300 yards, short range.

300 to 600 yards, mid range.

600 to 1,400 yards, long range.

1,400 to 2,000 yards, extreme range.

Firings.

541. The instructor will give the closest attention to the execution of the firings, and always exact the most rigid fire discipline.

542. The firings are always executed at a halt. If the squad be in march, it halts at the preparatory command for firing and loads, and kneels or lies down if so specified in the command.

543. Volley firing is executed, the squad closed or deployed, by the same commands and means as in close order. (Par. 146.)

More than three volleys will rarely be fired without intermission; this to allow the smoke to clear away, to steady the men, and to prevent waste of ammunition.

544. To fire at will: 1. *Fire at will*, or, 1. *Fire at will, kneeling* (or *lying down*), 2. *At* (such an object), 3. *At* (so many) *yards*, 4. **COMMENCE FIRING.**

At the fourth command, those skirmishers who can see the enemy aim deliberately, fire, load, and continue the firing until the command or signal: **CEASE FIRING.**

The corporal may permit a few men only, usually the best shots, to fire; for this purpose he calls the men by name and then gives the same commands as before; the intensity of the fire is thus regulated by varying the number of men firing.

545. To fire as skirmishers with counted cartridges: 1. *Fire one* (*two* or *three*) *round*, 2. *At* (such an object); 3. *At* (so many) *yards*, 4. **COMMENCE FIRING.**

At the fourth command those skirmishers who can see the enemy open fire. Each man, after firing the number of cartridges indicated, executes *cease firing*.

To fire another series: **FIRE ONE (TWO OR THREE) ROUND.**

The instructor will see that the number of cartridges indicated is never exceeded.

546. In the rapid fire, the number of cartridges is not limited; when used in advancing to the attack, the instructor orders bayonets fixed and sights laid down, and then commands: 1. *Rapid fire*, 2. **COMMENCE FIRING**.

The men fire straight to the front at the feet of the enemy, and continue to fire until the command or signal: **CEASE FIRING**.

INSTRUCTION ON VARIED GROUND.

547. The instruction at first will be individual; the movements will afterward be executed by the entire squad.

548. This instruction is directed by the company officers; it is given on ground which has been previously selected with reference to the movements to be executed. The location should be frequently changed to accustom the men to new situations, and care will be taken never to order movements at variance with the accidents of the ground.

549. Having conducted the squad to a point overlooking the vicinity, the instructor will call attention to the form of the ground and the different military purposes to which its features are adaptable, using and explaining the military terms that apply; he will require the men to point out the leading features of the country in sight or near their position, with all that concerns the streams, roads, woods, inhabited places, etc.

550. He will explain how to determine the points of the compass, the points of sunrise and sunset, the position of the sun at different hours of the day, and the length of the shadows cast by objects, persons, etc.

Use of Cover,

551. The instructor must impress upon the men that they must take positions from which they can best see and fire upon the enemy.

552. The best kind of cover is that which, while it masks the skirmishers from the sight and fire of the enemy, affords favorable conditions for firing and for readily advancing and retiring.

553. In order to obtain a rest for the rifle, and at the same time expose the least part of the body while aiming, the instructor explains the following methods :

Take post preferably behind the right of walls, rocks, heaps of stone or earth, and in the windows and doorways of the houses on the left side of a street ; behind a tree, rest the rifle on a limb to the right, or rest the forearm against the right side of the trunk.

Behind embankments of earth, in ditches and furrows, kneel or lie down and rise slightly to fire ; lie down in rear of a crest or the edge of a plateau, keeping the slope toward the enemy in view.

At the edge of a wood, where there is no ditch nor bank of earth, remain a little back from the edge, under the cover of the first trees.

The instructor explains how to prepare the crest of a wall, and how to pierce loopholes or construct platforms when the wall is too high to fire over.

554. The instructor explains the circumstances under which each accident of the ground would be valuable as cover, and how to use it, both in its original condition and by modifying it, against an enemy supposed to be in a certain direction.

The recruits are then required to post themselves near points indicated, so as to be under cover and in position to fire upon a point about six hundred yards distant, indicated as the position of the enemy ; each man selects his own position so as to have a good view of the objective, and sets his sight at the range indicated. The men then change places.

The exercise is repeated on different ground and with a different objective.

555. A well-instructed soldier or non-commissioned officer is then placed in the position of the enemy and required to advance upon the skirmishers; the latter will carefully observe his movements and aim at him whenever he exposes himself, adjusting the sight to agree with the distance (Par. 536).

556. When the recruits have learned to post themselves at points indicated by the instructor, they are exercised in selecting their own points, advancing from cover to cover. The instructor sends a man to a point about six hundred yards distant to represent the enemy; a recruit is then directed to advance upon him. In order to keep out of sight of the enemy, the recruit must make the best use of cover, but must not deviate too much from his direction; he must stoop and even creep or crawl, but, if possible, never lose sight of the enemy; open ground exposed to the fire of the enemy should be crossed at a run, by rushes of about thirty yards, then taking the lying position and raising the head in order to see the enemy.

The rushes should not, as a rule, exceed fifty yards, else the skirmishers will be winded and unable to aim accurately.

In this manner he should advance to about 200 yards from the enemy, and nearer if the character of the ground permit.

The man representing the enemy may be provided with blank cartridges and required to fire upon the skirmisher whenever he exposes himself sufficiently to afford a target (Par. 536).

557. When the recruits are well instructed in the use of cover, the movements are executed by squad.

The instructor points out the position of the enemy at least 600 yards distant, and states clearly the object of the movement. The corporal, as squad leader, gives the commands necessary.

Battle Exercises.

558. The squad executes on varied ground all the movements prescribed for close and extended order, special attention being given to the exercises in leading.

Those skirmishers who cannot hear or see the corporal regulate themselves upon the nearest men, who may transmit the commands to them in a low tone.

When the squad is proficient in the movements in extended order, the enemy is either outlined or represented.

In general the fire is simulated; but it is important, in these exercises, that blank cartridges should frequently be used.

Both parties cease firing when within fifty yards of each other; if they are deployed as skirmishers the attacking party may be ordered to charge; the men in each squad pass through the intervals in the other, each man passing to the right of the man directly in his front; both squads halt at the command of the instructor. The exercise may then be continued, the squads exchanging positions.

THE PLATOON.*General Rules.*

559. The chief of platoon is the instructor.

Before forming line of squads or deploying, he designates the center squad of the firing line and indicates the point of direction to the leader of the base squad.

In forming line of squads or skirmishers, the chiefs of sections, at the preparatory command, place themselves in rear of their base squads in line, or abreast of them in column; they see that the base squads keep the line of direction. The corporals take post in front of their squads in line at the preparatory command for forming line of squads; in deploying as skirmishers they take or keep their places in ranks, retaining supervision of their squads.

One section may form the firing line, the other the support; or the entire platoon may be placed in the firing line.

The post of the chief of platoon is between the firing line and support.

The chief of a section in the firing line is posted six paces in rear of the center of his section; he must be on the alert for signals from his chief of platoon. The chief of a section in support places himself six paces in front of his section.

The support halts until the firing line has advanced about 150 yards, or if the deployment be made by the flank, marches that distance to the rear, unless cover be found nearer the support.

If halted, the support stands, kneels, or lies down, according to the nature of the cover; on open ground it may deploy.

Marching by the flank under fire should be avoided.

Line of Squads.

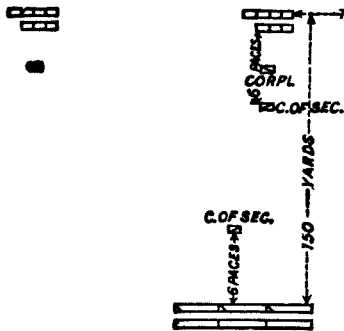

Pl. 93, Par. 560.

560. The normal interval between squads is about fifteen paces; when a greater or less interval is to be taken, it will be stated in the commands.

Marching in line, to form line of squads: 1. *Line of squads*, 2. *On (such) squad*, 3. **MARCH**.

The corporal of the base squad leads it (Pars. 515 and 516) in the indicated direction; the corporals to the right of the base move their squads obliquely to the right, those to the left, obliquely to the left;

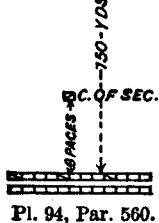
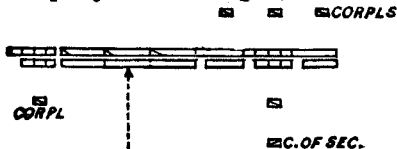

Pl. 94, Par. 560.

each moves to the front when at his interval from the squad next toward the base.

When the base squad arrives on the line, the chief of platoon commands: 1. *Platoon*, 2. **HALT**.

The base squad halts; the others are halted on arriving on the line. On halting, the corporals place themselves three paces in rear of their squads.

If marching in double time, or in quick time and the command be *double time*, the base squad advances in quick time; the others move in double time and take the quick time on arriving on the line; the corporals keep their places in front of their squads.

If at a halt, the base squad stands fast; the others face and march away from the base squad; each corporal halts his squad when it has gained its interval.

Being in Column of Fours, to Form Line of Squads.

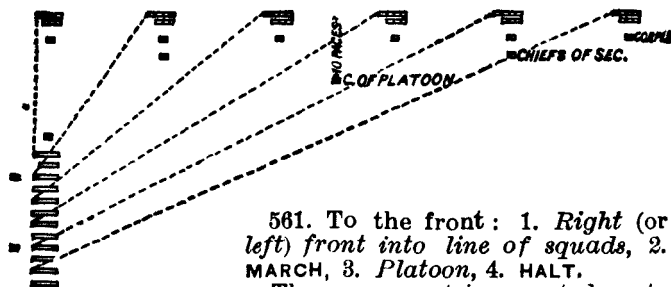

Pl. 95, Par. 561.

The movement is executed as in Par. 210; the corporals leading their squads to their proper places in line.

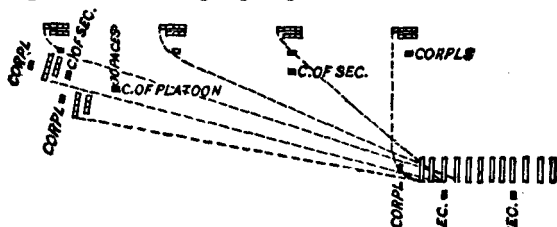

562. On right or left: 1. On right (or left) into line of squads, 2. MARCH, 3. Platoon, 4. HALT.

Pl 96, Par. 562.

Executed as in Par. 208, except that each corporal leads his squad to its proper place in line by the shortest route.

To Deploy as Skirmishers.

563. Being in line of squads: 1. *As skirmishers*, 2. MARCH.

Executed by each squad (Pars. 523 and 524.)

These commands may be given at any time after the commencement of the movement to form line of squads; the squads that have their intervals deploy at once, the others when they gain their intervals.

564. In exceptional cases, the platoon may be deployed in the same manner as a squad.

Being in line: 1. *As skirmishers, on (such) squad*, 2. MARCH.

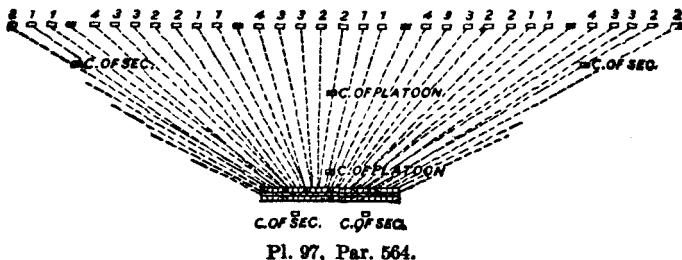

The deployment is made as in the squad (Pars. 523 and 524), number two front rank of the base squad being the base skirmisher; all the men of the line deploy on him; the squad leaders see that the men of their squads halt or march to the front as they individually gain their intervals.

To Increase and Diminish Intervals.

565. Being in line of squads: 1. *On (such) squad, to (so many) paces, extend (or close)*, 2. MARCH.

The squads open from or close toward the base squad. If marching, the movement is executed obliquely; if at a halt, by the flank.

Being deployed as skirmishers: 1. *On (such) squad, to (so many) paces, extend (or close)*, 2. MARCH.

The skirmishers to the right and left of number two front rank man of the base squad extend from or close toward him (Par. 525).

The Assembly.

566. The chief takes post where his platoon is to form, and signals or commands: 1. *Assemble*, 2. MARCH.

The squads move promptly toward him and re-form the platoon.

To assemble by squads: 1, *Assemble by squads*, 2. MARCH.

Executed by each squad (Par. 532).

567. To cause one or more squads to take a certain formation, the chief of platoon designates the squads and gives his orders.

Marchings.

568. Being in line of squads or skirmishers, the chief of platoon indicates the point of direction to the leader of the base squad and commands: 1. *Forward*, 2. *Guide right (left or center)*, 3. MARCH.

The base squad marches in the given direction; the others march abreast of the base, keeping their intervals.

569. To march to the rear: 1. *To the rear*, 2. MARCH. 3. *Guide right (left or center)*.

The chief of platoon indicates the point of direction to the leader of the base squad after the line has faced to the rear.

570. To make a slight change of direction, the chief of platoon indicates the new point of direction; the squads conform promptly to the movements of the base.

To make a considerable change, the chief of platoon indicates the new point of direction and commands: 1. *Change direction to the right (or left)*. 2. MARCH.

The right squad, which is the base, changes direction as if alone (Par. 530), and halts ; the others conform to the new alignment.

571. The platoon in line of squads or skirmishers is marched by the flank and again in line by the commands and means prescribed for the squad (Par. 528).

Firings.

572. The platoon and section, whether closed or extended, execute the firings as explained for the squad.

Volley firing may be used when the front is of such extent as to be controlled by the voice.

To fire by section or squad, the chief of platoon commands : 1. *Fire by section (or squad)*, 2. (So many) *volleys*, indicates, when desirable, the objective and range, and adds : 3. **COMMENCE FIRING.**

Each section or squad executes the firings as if alone.

The corporals take part in the firing except when the fire is by squad.

The chief of platoon may designate one or more squads to fire.

573. A section constituting the firing line executes the preceding movements by the same commands and means, under the orders of the chief of section.

Line of Sections.

574. The normal interval between sections of three squads each is about forty-five paces ; between sections of two squads each, about thirty paces.

The platoon forms line of sections, marches in this formation, and increases and diminishes intervals between sections as explained for squads, substituting *section* for *squad* in the commands and explanations.

The section forms line of squads or skirmishers, rallies, assembles and executes the firings and all other movements in extended order as explained for the platoon.

To Reinforce the Firing Line.

575. When there are intervals in the firing line, either on the outer flanks or between the groups, the reinforcement is placed in these intervals. This method, called the group reinforcement, will be used when practicable.

Advancing or being at a halt under cover, the firing line may diminish intervals toward one flank, the support deploying and moving up into the space made vacant.

Under a heavy fire, the line may be reinforced by deploying the support on the march, the men of the support placing themselves on the line between the skirmishers; officers and non-commissioned officers take charge of their proportionate parts of the front, and the action progresses as if no mixing had taken place. This method should be used only when the emergency demands a prompt reinforcement above all other considerations.

The Rally.

576. The chief of platoon moves rapidly to the squad or place selected as a rallying point, and signals or commands: **RALLY.**

The firing line rallies as explained for the squad. The support approaches and selects a position from which it can render the most effective assistance.

To rally by sections, the chief of platoon commands: **RALLY BY SECTIONS**, and then joins one of the sections.

The chiefs of sections hasten to place themselves in the center of their sections, signal, and repeat the command.

To rally by squads: **RALLY BY SQUADS**. The squad leaders make the signal; the chiefs of sections and platoons join the nearest squads.

When, as a result of reinforcing, sections and squads are mixed, each group rallies on the chief who commands it at the time.

As soon after rallying as practicable the platoon is assembled or again deployed.

THE COMPANY.

577. In battle formation, when part of a battalion, the company is in two echelons, a firing line and a support. In battalion, the fighting front of a company is usually twice its front in close order.

Acting alone, the company is in three echelons; a firing line, a support, and a reserve.

The distances between these echelons vary with the nature of the ground and the effectiveness of the enemy's fire.

578. On the offensive, the company, acting alone, may place at first only one section in the firing line, with one in support; the other two constitute the reserve.

On the defensive, two sections constitute the firing line, one the support; and one the reserve.

579. As a rule, the sections to be designated for the firing line are the center sections in line, or the leading sections in column or line of columns. A platoon may be designated for the firing line.

580. The company forms line of squads or sections, deploys as skirmishers, increases and diminishes intervals, assembles, rallies, and executes the marchings and firings by the commands and means prescribed for the platoon.

Positions and Duties of Officers.

581. The captain is the instructor. He takes post between the firing line and the support, or, if the formation be in three echelons, near the support. He designates the sections for the firing line, support, and reserve, directs the action of the whole company, controls the reinforcement of the firing line, and keeps up the supply of ammunition, regulating distribution and expenditure. His orders, given by word of command,

signals, or delivered by orderlies, are directed to the commanders of the firing line, support, and reserve. A musician remains with the captain.

The first lieutenant commands the reserve, if there be one, otherwise, the support.

The second lieutenant commands the firing line when it consists of only one section, or of one section from each platoon.

The third lieutenant, if there be one, may be assigned by the captain; if the formation be in three echelons, he usually commands the support.

The first sergeant, if not in command of a platoon or echelon, takes post near the captain.

If the firing line consist of an entire platoon, it is commanded by its own lieutenant; the other lieutenant commands the reserve or support.

When the whole company is in the firing line, each lieutenant commands his own platoon.

The commander of the firing line is ten paces in rear, and the commanders of the support and reserve ten paces in front of the centers of their respective echelons.

The commander of the reserve maintains communication with the support and with the captain, sending forward men to act as messengers and repeat signals.

The commanders of echelons give the commands necessary for the execution of the orders of the captain; they give their special attention to the control and direction of the fire and to maintain cohesion and concert of action.

582. Before forming for attack or defense, the commander of a force acting alone makes the reconnoissance necessary to determine the best disposition to be made.

Commanders of companies and larger units forming part of larger commands throw out scouts in their immediate vicinity. The number of scouts depends upon

the nature of their duties and the extent and character of the front. The commander will give them such specific instructions as circumstances require.

Scouts sent out in front of the firing line convey information acquired, by means of signals previously agreed upon.

These rules are general.

THE OFFENSIVE

The Company in Battalions.

583. When first coming within the zone of artillery fire, the company is formed in line and advances until the artillery fire becomes effective (on open ground, about twenty-five hundred yards from the enemy).

The captain then orders a few scouts sent forward (usually from the sections to be in support), designates the non-commissioned officer to command them, indicating the objective to him and to the chiefs of platoons and sections.

The scouts must advance at an increased gait, unless the company be halted.

The captain then designates two sections, preferably the second and third, for the firing line; the first and fourth for supports; gives the necessary instructions for the extension, and when the scouts have gained about one hundred and fifty yards to the front, commands: 1. *Form for attack*, 2. MARCH.

The second lieutenant places himself in rear of the center, designates the center squad and commands: *Guide center*.

The first lieutenant commands: 1. *First and fourth sections*, 2. HALT.

The chiefs of sections designate their sections and repeat the cautions necessary.

587. During this portion of the advance, the firing line will close upon its center, in order to make space for the supports to come up on the outer flanks.

The support has been drawing nearer to the firing line without waiting for orders, taking the formations most favorable for reinforcing, keeping under cover as far as practicable.

588. The firing line may advance from cover to cover by rushes executed by the whole line if possible, or by alternate sections.

589. The arrival of supports upon the line should usually be the signal for a rush forward.

590. When the line has approached within about five hundred yards of the enemy's position, alternate rushes will probably be necessary; the lieutenant gives the instructions while the men are lying down or behind cover, and then commands: 1. *Advance by rushes*, 2. *Third (or second) section fire two (or three) volleys*, 3. *Second (or third) section forward*.

The chief of the third section gives the commands for the volleys.

The instant the first volley is fired the chief of the second orders his section forward at double time; having advanced about fifteen yards, or to cover if there be any, he halts it by the commands: 1. *Fire two (or three) volleys (kneeling or lying down)*, and completes the commands for the volleys.

The instant of the delivery of the first volley by the second section, the third moves forward at double time about fifteen yards in advance of the line occupied by the second. The third section then fires the specified number of volleys, the second advances about fifteen yards beyond the third, and so on; the attack is thus continued, each section advancing under cover of the fire and smoke of the other, the base squad keeping the line of direction.

591. Volleys will be used to the last practicable mo-

ment. The chiefs of sections and the squad leaders assist in maintaining the strictest fire discipline.

592. During this period of the attack, as soon as it becomes necessary to increase the intensity of the fire, the captain sends forward the supports to reinforce the firing line.

The sections of the support reinforce the sections of their own platoons, advancing under cover of their fire and taking position so as to join in the next rush.

In moving forward to join the firing line, the supports move rapidly in order to avoid loss, and reinforce as in Par. 575.

The first lieutenant moves forward with the first section, and each lieutenant takes command of his own platoon; the rushes may then be made by platoon.

In emergencies the commander of the support may reinforce without waiting for orders.

593. As the company approaches the enemy's position the captain selects favorable ground from which to make the assault, and having attained this position commands: *Rapid fire*.

Platoon commanders then order bayonets fixed, caution the men to lay down the sights, and command: 1. *Rapid fire, kneeling*, 2. **COMMENCE FIRING**.

If any of the supports have not been brought up, they join the line at the command *rapid fire*.

To charge, the captain signals: **CEASE FIRING**, and commands: 1. *To the charge*, 2. **MARCH**.

The men rise and advance in double time.

Having arrived at about thirty yards from the enemy's position, the captain commands: **CHARGE**.

The men charge bayonet, quicken the pace and advance upon the enemy.

Having driven the enemy from his position, the captain selects ground in front favorable for firing upon the retreating enemy, or for resisting a counter attack,

and causes the assembly to be sounded, or if necessary, the rally.

In case of repulse, the captain at once prepares to renew the attack.

Relieving the Firing Line.

594. In the exceptional cases in which the firing line must be relieved, the captain notifies the firing line and gives orders to the support which is to replace it.

The support deploys so as to complete the movement in rear of the line and moves up into the intervals, or passes through the firing line, which is then marched to the rear and assembled.

If the line is marching to the rear, the captain orders the support to deploy; the firing line passes through the line thus formed, is assembled and becomes the support or a part of it.

The Company Acting Alone.

595. The captain determines upon the direction and character of the attack and indicates the rallying point.

The attack is conducted on the principles explained for the company in battalion.

The firing line makes the front attack; the support reconnoiters and protects the flanks, and supports the front attack; the reserve, according to circumstances, makes a flank attack or participates in the front attack.

When the support is absorbed in the firing line, the reserve, which has been drawing nearer during the advance, should be about 150 yards from the firing line.

The action from this stage is conducted as for the company in battalion; the reserve reinforcing the firing line as prescribed for the support.

Having driven the enemy from position, a part or even the whole of the company should be used to

pursue him unless pursuit would endanger advantages already gained.

THE DEFENSIVE.

The Company in Battalion.

596. When the captain is ordered to occupy a defensive position, he conducts his company to the point selected and sends forward scouts, who connect with those from the adjacent companies.

The captain indicates to each subdivision the position it is to occupy and the defensive works to be constructed, such as abatis, shelter trenches, etc.

The division and formation of the company are, in general, the same as on the offensive.

To secure superiority of fire, a company may have three sections in the firing line and one in the support from the beginning of the action.

The first resistance of the scouts should be for the purpose of causing the enemy to deploy and disclose his intentions. The captain then orders the battle formation.

Fire is opened as soon as it can be made effective.

Certain subdivisions may be designated to fire upon the enemy's supports and reserves.

The firing line is reinforced as in Par. 575.

When the enemy arrives at about 500 yards from the position, the support is habitually absorbed in the firing line, and the defense is continued with the assistance of the battalion reserve.

If the enemy be repulsed, the company takes the offensive.

If the enemy succeed, the company withdraws and forms at the rallying point.

The Company Acting Alone.

597. Depending upon the distance of the enemy, the company arrives at the position in battle formation or in order of march.

In the first case, the firing line is established on the position to be defended; the support and reserve are placed under cover; patrols are sent out in front and upon the flanks to reconnoiter.

In the second case, the advance guard halts at the position and sends scouts and small patrols out in front and upon the flanks. The captain makes his preliminary dispositions as explained for the company in battalion; then takes the battle formation.

The captain disposes the support and reserve so as to protect the flanks of the firing line.

The supports, either wholly or in part, may be placed in the firing line from the very beginning of the engagement, in order to secure superiority of fire and a front at least equal to that of the attack.

The captain keeps a portion of his reserve in hand, to execute a counter attack at the moment the enemy reaches the position, or to cover the retreat.

Advantage should be taken of every opportunity to make short and energetic counter attacks upon the weak points of the enemy's line. When the enemy is repulsed, he should be damaged as much as possible by increased energy of fire and should be pursued unless this would compromise the security of the position.

If necessary to retreat, the captain disposes the remainder of his reserve in such position as to most readily hold the enemy in check, near one of the flanks, if possible; the firing line un.masks the reserve and takes position in rear of it, the reserve protects the retreat of the firing line and retires in turn under its protection.

The company thus retires from position to position; it is assembled and placed in column of route when out of range of the enemy.

Unless ordered to the contrary, a position should not be abandoned except in the last extremity.

Action Against Cavalry.

599. As a principle, the advance or attack of infantry should not be checked by the appearance of cavalry. The latter should be kept at a distance by means of volleys executed by subdivisions designated for this purpose.

If in line, and attacked in front, the company should receive the charge without changing its formation. If attacked in flank, the company, or a part of it on the threatened flank, changes front to face the attack.

If in battle formation, and cavalry attack as foragers or in mass, it is better to receive the attack at a halt, than to rally. Only such dispositions are made as will quickly develop the greatest intensity of fire. If attacked in front, the firing line opens fire; the sections of the support are placed in rear of the flanks to guard the latter and fire upon the horsemen who envelop them. If attacked in flank, the sections of the support and reserve face so as to find themselves arranged in echelon ready to protect the threatened flank by their fire. If attacked by echelon, the fire will not be directed upon a fraction already repulsed, but upon the one following it.

In a personal encounter the foot soldier should gain the left flank of the horseman.

Defense and Attack of Artillery.

599. Infantry under artillery fire, seeks to lessen its effect by appropriate formations and use of cover.

Defense.

600. A commander of infantry supports the batteries in his vicinity.

Artillery separated from the other arms is furnished with a special support.

An infantry support for artillery protects the flanks and rear of the batteries and opposes the enemy's infantry or cavalry acting against them; it is usually posted on the flanks.

Attack.

601. The company is disposed as for the attack of a position, but the firing line may be deployed as skirmishers at a greater distance and the front may be more extended; the rear echelons, if need be, are also deployed.

When artillery is in motion, the fire is directed preferably upon the horses.

THE BATTALION.

602. The principles of instruction for the squad, platoon and company in extended order apply.

603. The battalion is formed for battle in three echelons; a firing line, a line of supports and a reserve.

In battalion, the firing line and supports together are designated the *fighting line*; it may be composed of one, two or even three companies.

Extension.

604. Whatever be the formation of the battalion, the major designates the company or companies to form the fighting line and those for the reserve, gives instructions for forming line of sections or squads, or deploying as skirmishers, indicates the point of direction and the object of the movement, and commands: 1. *Form for attack*, 2. (Such) *the base company*, 3. **MARCH.**

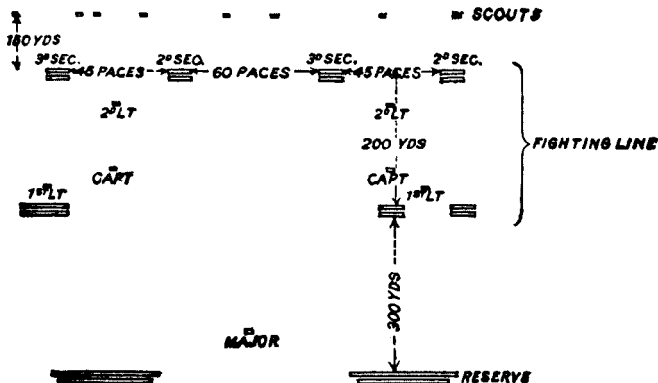

The captains of companies for the fighting line designate the sections for supports, and cause their companies to advance in the given direction and take the battle formation. The firing line extends as directed by the major and according to the principles explained for the company.

The extension completed, there should be in the line of skirmishers an interval of about fifteen paces between the companies, which they should preserve during the advance.

The reserve is held about 300 yards in rear of the line of supports.

The fighting front of a battalion in regiment should not exceed one and one-half times the front of the battalion in close order.

The major posts himself where he can best observe and direct the progress of the action, which is usually between the line of supports and reserve; if he quits this place, he leaves a man there to tell where he may be found.

The senior officer with the reserve companies takes command of them when they are united in close order.

Mounted officers dismount when the battalion opens fire; the horses are taken back to the reserve of the regiment.

When the color of the regiment is with a battalion that takes the battle formation, it joins the regimental reserve, whose commander either directs the color to join a certain company or detaches a guard to remain with it during the action.

Marchings.

605. The battalion in battle formation regulates its march as explained for marching in line. The base squad keeps the line of direction independently of the movements of the companies, under the supervision of

the squad leader and the chief of section to which this squad belongs; if the companies for any reason are obliged to give way they regain their places as soon as possible.

The supports and reserve conform to the movements of the firing line.

It is important that the line of direction should be correctly determined before taking up the advance; if, however, changes of direction become necessary they are made gradually by slightly changing the direction of the base squad from time to time.

Relieving and Reinforcing the Firing Line.

606. These movements are executed on the principles explained for the company, either as ordered by the major, or, in each company, by its captain. Relieving skirmishers is, however, an exceptional movement.

Assembling and Rallying.

607. When no longer compelled to remain in extended order, the major assembles the battalion.

The major may order one or more, or even all the companies in the firing line, to rally.

The reserve approaches and selects a favorable position for supporting the companies that have rallied.

THE BATTALION IN ACTION.

General Rules.

608. The major regulates the progress of the action, sees that the firing line advances upon the indicated objective, hastens or delays the reinforcement by the supports, and disposes the reserve so as to guard against surprise; leaving the execution of details to his subordinates, he exercises a general control, and endeavors constantly to increase the energy of the action.

When necessary, he indicates what measures are to be taken to assure the occupation of the position, but should leave to each commander the discretion necessary to enable him to profit by all circumstances.

Each captain in the fighting line regulates the march of the line within the limits assigned him, determines the distances to be passed over in rushes, and brings his support upon the firing line, pursuant to orders, or without orders if the necessities of the moment require; he directs the fire and regulates its intensity.

THE OFFENSIVE.

The Battalion in Regiment.

609. When the major receives orders to attack, he gives his instructions (Par. 604), and commands: 1. *Form for attack*, 2. (Such) *the base company*, 3. MARCH.

The companies in the fighting line conform to what has been prescribed for the company. (Pars. 583 to 594.)

The reserve conforms to the movements of the fighting line, and, without waiting for orders, gradually draws nearer, so as to be ready to replace the supports when the latter have been absorbed, the reserve companies taking the battle formation.

The attack is made as prescribed for the company. When the firing line is about 500 yards from the enemy's position, the first echelon of the reserve is about 100 yards and the second about 200 yards in rear of the firing line.

When the major thinks necessary he places one or more platoons of the reserve in the firing line. At about 200 yards from the enemy bayonets are fixed and the rapid fire is opened; the last of the reserve, in rear of the point at which the main effort is to be made, is held in readiness to reinforce the line.

The battalion in the second line of the regiment draws nearer so as to replace the battalion reserve if necessary, and take part in the charge.

If the rapid fire does not shake the enemy, the remainder of the battalion reserve is quickly brought up, and another rush made, followed by the rapid fire.

During this fire the battalion of the second line reinforces the firing line; at the signal from the colonel, the field music sounds the charge and the whole line rushes upon the enemy.

As soon as the position has been carried, the firing line advances until it has found a position favorable for firing upon the enemy. The parts of the reserve not in the firing line hold themselves in readiness to pursue the enemy or to resist a counter attack.

The first opportunity is taken to assemble the companies on the captured position. The major forms the battalion and disposes his troops so as to secure the position, and to pursue the enemy, if ordered.

If repulsed, the line rallies under the protection of the reserve.

The Battalion Acting Alone.

610. The action is conducted on the general principles explained for the battalion in regiment; the front may be more extended, but the major must be able to direct

the action and secure the increasing power of the successive efforts. If the strength of his command warrants it, he may attack both in front and flank. He must cover his flanks and secure his line of communication.

The enemy having been located, the major makes his dispositions for attack.

If the attack succeeds, the battalion takes position and fires upon the enemy, as explained for the battalion in regiment, and, if opportunity offers, will pursue the enemy (Par. 595).

If repulsed, the rally is protected by the parts of the reserve that have not been engaged.

THE DEFENSIVE.

The Battalion in Regiment.

611. The reconnoissance and occupation of the position are made on the principles explained for the company acting alone under the protection of the patrols commanded by one or more officers; these patrols not only endeavor to discover the enemy's position and direction of attack, but also keep his scouts and reconnoitering parties at a distance.

As a rule, the battle formation is the same as on the offensive. When it is desirable to have an extended and dense firing line from the start, the two companies in the fighting line may be directed to keep but one section each in support. The same result is obtained by placing three companies in the fighting line, each having two sections in support.

The line of defense is in general determined by the configuration of the ground; the points that command a clear field of fire in front and afford cover should usually be strongly occupied. The different parts of the front should be able to assist each other, and should not be separated by impassable obstacles.

If time and circumstances permit, the position is strengthened by hasty entrenchments.

The strong points in the line, such as woods, fences, buildings, rising ground, etc., are placed in a state of defense or strengthened by field works; in the selection of these points the chief consideration is a clear field of fire toward the front and flanks.

The strong points are connected by shelter trenches, intervals being left to facilitate counter attacks and for passing from the defensive to the offensive.

The action is conducted according to the principles explained (Par. 596).

The dispositions of the rear echelons of the battalion depend upon the movements of the assailant; the defender uses every means to overwhelm by fire such bodies of the enemy as remain in close order; the supports are placed in the firing line in proportion to the necessities of the case. Troops in rear, firing over the heads of those in front, should use volleys only.

When all the supports are in the firing line and the enemy probably within 500 yards of the position, a part of the reserve reinforces the line; the other part is held ready either to add the effect of its fire to that of the line or to assist in the counter attack when the offensive is taken up.

In the last stage of the action, the firing line may, if necessary, be reinforced by the entire reserve.

If retreat becomes necessary, it is conducted as prescribed for the company. When all the battalion reserves have been absorbed on the firing line, the troops in the second line take position and protect the battalion while rallying, or, by an energetic counter attack, endeavor to gain the ascendancy.

When, in obedience to orders, resistance is not to be carried to the last extremity, the retreat is executed by echelons from position to position.

The Battalion Acting Alone.

612. The general principles stated for the company acting alone apply to the battalion.

The battalion should not deploy before the enemy's position is known.

The battalion takes position and prepares to receive the attack, observing the following conditions :

The front must be sufficiently occupied and extended from the beginning of the action ; this will usually require two companies in the fighting line ; the other two companies are held in reserve, in rear of the supports, covering the flanks and extending beyond them.

When the supports have been absorbed in the firing line, they are replaced by the reserve companies, which are disposed so as to protect the flanks.

When the front of the position is very strong, a relatively greater part of the command may be placed in the reserve to insure more decisive effect in counter attacks.

DISPOSITIONS OF A BATTALION.

Operating on a Flank of a Line.

613. The special object may be to secure the flank, to envelope the enemy's flank, or to engage the enemy at one point, while the regiment or brigade prepares and executes the principal attack at another. In these different cases the major conforms to the principles laid down for the offensive or defensive action of the battalion in regiment, as the case may require.

As Advance Guard of a Regiment.

614. The advance guard acts offensively or defensively according to circumstances. Its action is subordinate to that of the main body ; it should carefully avoid becoming so involved as to compel the latter to depart from its original purpose. The battalion as advance

guard acts on the offensive as prescribed for the battalion acting alone; on the defensive it may take the battle formation with three or even four companies at the first indication of the presence of the enemy; the strong points are occupied and the front extended as much as necessary to prevent being outflanked.

If the enemy without attacking shows himself in force the battalion occupies the strong points.

As Rear Guard of a Regiment.

615. The object of the rear guard is to retard the enemy so as to enable the main body to gain time or distance; it acts chiefly on the defensive.

If the battalion as rear guard be attacked, it will not carry resistance so far as to be cut off from the main body.

Advantage is taken of any want of precaution on the part of the enemy to draw him into ambush or to make sudden, short and energetic offensive returns.

The rear guard may sometimes take the offensive, for example: When it is guarding a defile during the passage of the main body, or when opposing the egress of the enemy at the outlet of a pass.

The rear guard should not fight to extremity except to secure the safety of the main body.

Against Cavalry.

616. The principles stated for the company apply to the battalion.

If there be time, the major may place the companies in echelon.

To this end he indicates the base company, the interval and distance which should separate the echelons and the relative positions of the companies.

The base company stands fast; the others are rapidly led by their captains to the places they are to occupy.

The echelons are formed by advancing companies on the flank farthest from the enemy's artillery; they are disposed in such a manner as to afford the heaviest possible fire without risk of firing into one another.

DEFENSE AND ATTACK OF ARTILLERY.

617. The principles stated for the company apply to the battalion.

Defense.

618. The companies are posted in front of the intervals between groups of batteries and on the flanks, so as not to hinder the fire of the artillery; they are held ready to meet the attack.

Attack.

619. The battalion is disposed as for the attack of a position; the parts in close order advance in echelons and thin lines; the advance is led on as rapidly as possible and the attack precipitated when within a short distance of the guns.

The action is conducted according to the general principles explained for the company, and the attacks should be made against a flank if possible.

If the artillery be supported by infantry, the major directs against the latter a sufficient force to silence its fire, and uses the remainder of his battalion against the artillery.

NIGHT OPERATIONS.

620. To be successful, a night attack should be a surprise; it should be prepared secretly, avoiding indications that might attract the attention of the enemy.

Once engaged, it is necessary to act vigorously and promptly.

It is essential to operate over ground known in advance.

It is equally important that the leaders of the different units be carefully instructed as to the parts they are to take, the field assigned them, the rallying points and the line of retreat.

On the offensive, the troops usually operate in compact formation, so as to be kept in hand and to prevent misunderstandings.

Under cover of darkness the assailant approaches, in order and silence, and without firing, as near as possible to the enemy's position; he then assaults resolutely, not replying to the fire, and comes as quickly as possible to the encounter, hand to hand.

On the defensive, when a night attack is expected, the position is reinforced by troops or strengthened by obstacles or hasty entrenchments; the positions to be occupied by the different units are indicated and understood beforehand.

After the opening of the action, all movements which could produce disorder or confusion are avoided.

The fire is directed particularly upon the approaches to the position.

THE REGIMENT.

621. The principles explained for the battalion apply.

A battalion in battle formation is said to be in the fighting line when it has any part in the firing line. This rule applies to larger commands.

The regiment is formed for battle in two or three lines depending upon the extent of front to be occupied; this should not exceed the front of the regiment formed in one line in close order increased by one-half the interval between it and the adjacent regiments.

When in two lines, two battalions constitute the fighting line; the other is posted as reserve about six hundred yards in rear.

When in three lines, one battalion forms the fighting line, one about six hundred and the other about twelve hundred yards in rear.

The reserve may be posted in rear of the center, or in rear of one or both flanks.

The colonel takes post near the center of the line of the battalion reserves of the fighting line; if called elsewhere he indicates his position.

He superintends the action and directs the majors of battalions in reserve when to reinforce.

Unless he specifies the formations for battalions in reserve, the majors adopt the formations they deem best suited to the ground and other circumstances.

THE BRIGADE IN BATTLE.

622. The formation depends upon whether the brigade is acting alone or with other troops, and varies in each case to suit the extent and character of the front to be occupied.

623. If formed in one line, two battalions constitute the fighting line of each regiment, the third battalion of each regiment being held as a regimental reserve. In this case there is no separate brigade reserve, unless furnished by another brigade.

624. In two lines, the two leading regiments constitute the fighting line of the brigade and are formed as above. The rear regiment, as a second line, constitutes the brigade reserve and is posted about six hundred paces in rear of the reserve battalions of the leading regiments; it will be given the battle formation if necessary.

If the brigade approaches the field of battle marching in column of fours, the general may order the leading regiments on the fighting line, without regimental reserves, and supply a battalion from the rear regiment to each regiment in the fighting line as a reserve. This formation is open to the objection of speedily disintegrating the rear regiment, and will be resorted to only when a rapid extension of front is of the first importance.

625. For a more powerful attack, the regiments may be formed side by side, each regiment in three lines. The colonels will avoid calling on their second battalions prematurely; the third battalion should not enter action without orders from the general.

626. The general will make such changes in the foregoing formations as are rendered necessary by the character of the action and the nature of the ground.

627. The general has no fixed position, but will always indicate where reports will be received.

628. If compelled to give an order to a battalion commander, the general should so inform his colonel as soon as practicable.

629. The general may direct when the troops composing the first line shall pass from close to extended order, or this may be left to the discretion of the regimental and battalion commanders; a reserve need not necessarily be posted in rear of the line; frequently it may be advantageously formed in echelon with that line. *This rule is general.*

To Withdraw the Brigade.

630. The general sends orders to the colonels: *Withdraw and form in one (or two) lines on (such) battalion, (such) regiment; or, Withdraw and form in column on (such) battalion, (such) regiment.*

The general indicates the position to be occupied by the designated battalion and the colonels add the necessary commands. The battalions form in the same order as before the deployment, or the general may change this order.

631. If the order be to *form in column*, column of fours will be understood, unless the general indicates another formation.

THE DIVISION IN BATTLE.

632. The division may be formed with one or two brigades in the fighting line and the others in the reserve, or the three brigades may be placed in the fighting line; in either case, each brigade takes one of the formations prescribed for the *brigade in battle*.

The artillery takes the positions assigned by the division commander.

Officers in command of the reserves will adopt such formations as will not unnecessarily interfere with the maneuvers of the other arms.

633. The division commander conducts the action on the principles prescribed for smaller commands.

634. The officers of the reserve will be constantly on the alert to prevent any panic that may arise among the troops of the first line spreading to their own.

635. The reserve is not necessarily united; the regiments and battalions composing it may be posted in rear of different parts of the first line.

ADVANCE AND REAR GUARD.

636. An *advance guard* is a body of troops thrown out in front of a marching column to cover its movements, to prevent surprise and gain information.

637. In an advance, it seizes advantageous positions and holds them until the main body comes up; or holds in check the advancing enemy until the main body can deploy and take up a position to meet him.

638. In retreat, it prepares the way for the main body, guarding and repairing roads, bridges, etc.; sweeping away any partisans or guerrillas. If hostile troops have outmarched the column and are in front of it, the advance guard performs duties of the same nature as in the advance.

639. The advance guard is divided into two nearly equal parts, the *vanguard* and the *reserve*.

The vanguard is subdivided into the *advance party* and the *support*. The advance party furnishes the *leading* and *flanking groups*. The support furnishes its own *flankers*.

640. A small advance guard, consisting of a company of infantry of one hundred men, may be disposed as follows :

A *point*, or leading group, consisting of three men under a corporal; a *flanking group* of three men on either hand, one hundred and fifty yards distant and somewhat retired; the remainder of the *advance party*, fourteen men, under a sergeant, at one hundred yards in rear of the point.

The *support* follows at one hundred and fifty yards in rear of the advance party, throwing out, if necessary, two *flanking groups* of three men each, slightly in advance of the support, and somewhat farther out than

the flankers of the advance party. The support, including its flankers, numbers twenty-five men. The commander of the vanguard is with the support.

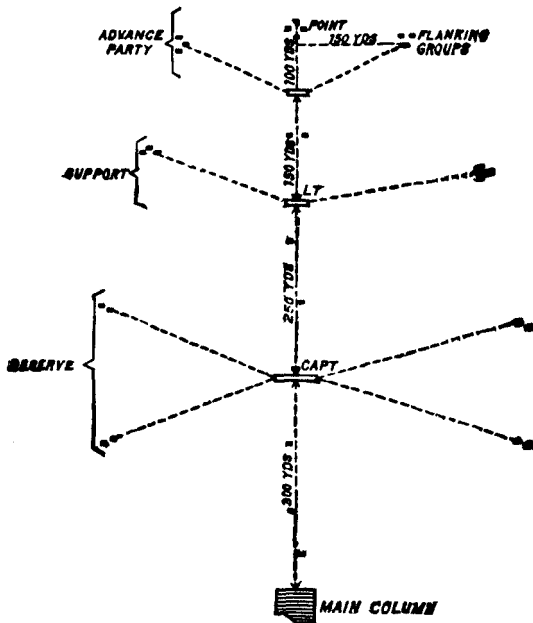

Pl. 100, Par. 640.

The *reserve*, one-half of the advance guard, follows at two hundred and fifty yards in rear of the support; the reserve may throw out flanking detachments at from two hundred to four hundred yards, on either or both flanks, and somewhat in advance and in rear of its position.

The commander of the advance guard is with the reserve.

The main column follows at three hundred yards in rear of the reserve, or eight hundred yards from the point.

When necessary, the support sends out one or two men to preserve communication with the advance party; the reserve may send out men to preserve communication with the vanguard and with the main body.

641. *Rear guards* are corresponding bodies in rear of the column. In a forward movement they protect the rear of the column from raiding parties or detachments, arrest stragglers, prevent pillaging, etc.

642. In a retreat they cover the column, checking the enemy, and delaying him so as to insure the safety of the column.

643. The example given of the order of march of a small advance guard serves equally well as a type for a rear guard of the same strength, if it be considered as faced to the rear throughout.

644. The strength of the advance guard in a forward movement varies from one-eighth to one-fourth of the whole force; in a very small force, one-eighth; in a very large force, one-fourth; and generally one-sixth. The rear guard is generally one-half the strength of the advance guard.

In retreat, the proportions given above for the advance guard would apply to the rear guard, and the advance guard would be half the strength of the rear guard.

It should be borne in mind, however, that these proportions vary according to circumstances, and must depend upon the judgment of the commander.

645. The foregoing rules must be modified to suit the varying conditions of advance and retreat.

OUTPOSTS.

646. The size of the detachment for outpost duty depends upon the strength of the main command, the proximity of the enemy, the extent of front to be covered, the character of the country, etc.; it should not, as a rule, exceed one-sixth of the whole force.

647. The object is to guard all approaches, to obtain the earliest information of the enemy's movements, and to obstruct and delay his advance.

648. The outposts should cover the entire front, extend well beyond the flanks and toward the rear.

Outposts are generally disposed as follows :

First :—A line of sentinels.

Second :—A line of small groups, called pickets.

Third :—A line of larger groups, called supports.

Fourth :—The reserve.

The reserve is sometimes omitted, when the supports hold a strong defensive line.

Posts in the line of sentinels are from one hundred to three hundred yards apart, and one or two men are placed on each post.

The sentinels keep themselves concealed and watch the ground in their front and between them and the posts on their right and left; at least one man on each post must always be on the alert.

The picket is posted about four hundred yards in rear of the center of the line of sentinels for which it furnishes reliefs. The picket, when necessary, sends out patrols.

The support is posted about six hundred yards in rear of the center of the line of pickets.

The reserve is about one thousand yards in rear of the line of supports, and about two thousand yards in front of the main body

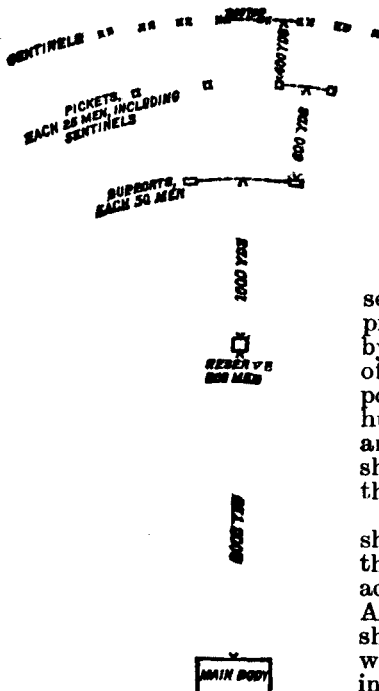

Pl. 101, Par. 649.

The distances given above will be modified according to circumstances by the commander of the outposts.

649. Plate No. 101 shows an outpost composed of an infantry battalion of four hundred men, covering a front of one mile.

650. The line of sentinels and the line of pickets may be replaced by a single line of posts of four men each. The posts should be about one hundred yards apart, and one man at each post should be continually on the alert.

The line of small posts should not be more than three hundred yards in advance of the supports. As a rule, this formation should be adopted only when the outpost line is in a close country and occupies a strong position.

MARCHES.

651. The average march for infantry is from fifteen to twenty miles per day.

652. When troops move in large bodies, and particularly in the vicinity of the enemy, the march should be conducted in several columns, in order to diminish the depth of the columns and to expedite the deployment into line of battle.

653. The order of march should state the time for each division to commence its movement, and the points where the division or its elements should enter the main route, so as not to interfere with the march of the division preceding or following, and to prevent fatigue from keeping men longer under arms than is necessary.

654. In route marches, regiments usually alternate in leading the brigade; in like manner brigades alternate in divisions, and divisions in corps.

655. In large commands, the roads, if possible, are left to the artillery and trains. The order of march should state whether the troops or trains should have the right of way.

656. Each brigade is provided with a corps of pioneers under charge of a commissioned officer. The pioneers precede the column for the purpose of removing obstacles and preparing the way for the troops.

Whenever fences, hedges, walls, ditches, or small streams are encountered, a passageway is made wide enough for the column to march without obstruction. This will prevent the column from lengthening out, and also prevent the fatigue and delay of regaining distances.

Pioneers, mounted or in wagons when practicable, should repair the roads for the trains.

657. When practicable, marches should begin in the morning after the men have had their breakfasts.

After marching half or three-quarters of an hour, the

troops are halted for fifteen minutes to allow the men to relieve themselves and to adjust their clothing and accouterments.

After the first rest there should be a halt of ten minutes every hour.

On long marches, halts of half or three-quarters of an hour should be made for meals. The halt, if practicable, should be made in the vicinity of wood and water.

When long distances have to be overcome rapidly, it is done by changing gaits; the most favorable ground is selected for the double time; special care should be taken not to exhaust the troops immediately before engaging the enemy.

658. No man will be permitted to leave the ranks without permission of the captain; if the absence be for a few minutes only, the man will leave his arms and accouterments with the company till he rejoins it; if he needs medical attendance, the captain gives him a pass to the surgeon, showing his name, company, and regiment; if he is unable to return to his company, the surgeon admits him to the ambulance, or indorses the pass, stating that he is permitted to fall out on account of sickness.

The provost guard of the brigade marches in rear of the brigade.

It is the duty of all officers and non-commissioned officers to suppress straggling. Men who fall out of ranks are examined by the provost guard, and if absent without authority, they are arrested and sent to their regiments.

659. Whenever delays occur in front, the brigades may form in column of battalions and stack arms. It is the duty of all commanders, within their commands, to investigate, personally or by means of staff officers, every cause of delay, and staff officers should frequently be sent ahead for the purpose of gaining any information that may shorten the march and lessen the fatigue of the troops.

CAMPING.

660. In the presence of the enemy the troops bivouac in position ; if safety permit, tents may be pitched immediately in rear of the line of stacks ; the tents of the company officers in rear of their companies, the tents of the field and staff in rear of the center of the line of company officers.

661. When not in the presence of the enemy, each battalion usually camps in column of companies at convenient distances. The tents of each company are arranged in two lines, facing each other, or in one line, all facing in the same direction ; the tents of the company officers are arranged in line parallel to the flank of the column and at a convenient distance, facing the company street, captain's tent on the right, his lieutenants' on his left. The first sergeant's tent is on the flank of the company toward the officers' tents.

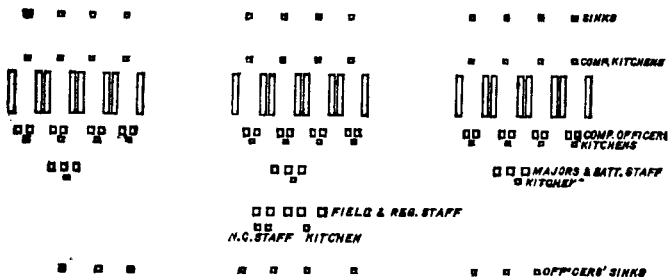

Pl. 102, Par. 661.

The tents of the major and his staff, when practicable, are in line in rear of and parallel to those of the

company officers; the major opposite the center of the column; the adjutant is on the left of the major; the other staff officers are on the left of the adjutant.

The colonel is opposite the center of the column in rear of the line of majors, the lieutenant-colonel on his right, the adjutant on the left of the colonel, the other staff officers on the left of the adjutant.

The tents of the non-commissioned staff are in rear of the tents of the staff; they may be assigned to tents in the companies.

The kitchens of the men are in line on the flank opposite the company officers; they may be placed at the head or rear of the column; the sinks for the men are outside of the line of kitchens.

The kitchens of the officers are in rear of their tents; the sinks for the officers are in rear of the line of tents of the field and staff.

The positions of the color line, guard tents, field hospital, officers' horses, baggage wagons, etc., are prescribed by the commanding officer.

The width of the company streets and the streets in front of the company officers, majors and staffs, and colonel and staff, varies with the nature of the ground and the strength of the command.

Ground for camping should be susceptible of good drainage, and should be near wood and water.

When time will permit, all the streets are ditched; a shallow ditch is also made around each tent.

When straw, leaves, or boughs are at hand, the men should be required to raise their beds above the ground; attention to this rule, to cleanliness, and to the proper cooking of food will greatly diminish the number and frequency of camp diseases.

On arriving in camp, if orders are not communicated for resuming the march the following morning, sinks should at once be dug. The sinks should be concealed

by bushes or tents, and should be covered daily with fresh earth.

In winter quarters, tents may be pitched on frames made of boards or split logs, the bunks of the men being arranged one above another.

HONORS TO BE PAID BY TROOPS.

662. Honors, salutes, etc., to be paid by troops are prescribed in Pars. 11, 422 to 441, inclusive, and 516 to 527, inclusive, A.R., 1889. [See Appendix.]

CEREMONIES.*General Rules.*

663. On occasions of ceremonies, except funeral escort, troops are arranged from right to left in line and from head to rear in column, in the following order: First, infantry; second, light artillery; third, cavalry. Artillery serving as infantry is posted as infantry. Dismounted cavalry and marines are on the left of the infantry. Engineer troops are on the right of the command to which they are attached. In the same arm, regulars, volunteers, and militia are posted in line from right to left, or in column from head to rear, in the order named. On all other occasions troops of all classes are posted at the discretion of the general or senior commander.

664. When forming for ceremonies, the companies of the battalion are posted according to the rank of the company commanders present, as shown in the table in Par. 253; the battalions of the regiment, the regiments of the brigade, the brigades of the division, and the divisions of the corps are posted from right to left in line, or from head to rear in column, in the order of rank of their respective commanders present, the senior on the right or at the head.

665. At parades and reviews, the field and staff are habitually mounted; they are dismounted when the reviewing officer is dismounted.

666. A non-commissioned officer in command of his company retains his post on the right of the right guide when the battalion is in line; he has the post of the captain when the battalion is in column. At parade, before bringing his company to parade rest, he steps two paces to the front and faces to the left; having given

his commands, he resumes his post and comes to parade rest. At inspection, when ranks are open, his post is on the right of the right guide.

In exercises in the manual, non-commissioned officers commanding companies or platoons execute only the order and parade rest ; in rendering honors, the present and carry ; while marching, the right shoulder and carry.

GENERAL RULES FOR REVIEWS.

667. The adjutant or adjutant-general posts men or otherwise marks the points where the column changes direction, in such manner that the right flank in passing shall be about twelve paces from the reviewing officer. He also marks a point about fifty paces to the left of the reviewing officer, where each company is brought to the carry at the command of its captain ; the companies successively resume the right shoulder about fifty paces beyond the reviewing officer.

668. The post of the reviewing officer, usually opposite the center of the line, is marked by a flag.

The reviewing officer should be at the flag before the head of the column reaches that point ; before that time he may take any position to observe the movements of the troops.

669. The reviewing officer, his staff, and others accompanying him salute the color by uncovering, whether the color salutes or not ; the reviewing officer alone returns the salutes of commanders of battalions, batteries, and squadrons, and all higher units.

670. The staff of the reviewing officer is in single rank, six paces in rear of him, in the following order from right to left: Chief of staff, adjutant-general, aids, then the other members of the staff in the order of rank, the senior on the right ; the flag and orderlies place themselves three paces in rear of the staff, the flag on the right.

671. Officers of the same or higher grade and distinguished personages invited to accompany the reviewing officer place themselves on his left; their staffs and orderlies place themselves on the left of the staff and orderlies of the reviewing officer; all others who accompany the reviewing officer place themselves on the left of his staff, their orderlies in rear.

672. While riding around the troops, the reviewing officer may direct his staff, flag, and orderlies to remain at the post of the reviewing officer, or that only his personal staff and flag shall accompany him.

673. The staff officers, in passing around the troops, or in review, ride in one or more ranks, according to the number.

674. Commanders of brigades and divisions take their places in the column in time to allow the commanders in front of them to take their places when at one hundred paces from the reviewing officer.

675. The staff, flag, and orderlies of brigade, division, and corps commanders place themselves in the order prescribed for the staff, flag, and orderlies of the reviewing officer.

676. Commanders of brigades, divisions and corps, and their staff officers draw sword when they take their places in column before passing in review; they return sword immediately after placing themselves on the right of the reviewing officer.

677. When a commander of a corps, division, brigade, or regiment turns out of the column to place himself near the reviewing officer, his post is on the right of the commanders already there; his staff will arrange themselves in single rank on the right of the staff already there; his flag and orderlies in rear of his staff. Each commander, when his rear company has passed, salutes the reviewing officer, and with his staff and orderlies rejoins his command.

678. The brigade commander, while the reviewing officer is not in front or in rear of his brigade, may cause it to stand *at ease*, *rest*, or *stack arms*, and *fall out*, and resume *attention* so as not to interfere with the ceremony.

679. The colonels repeat the commands of the brigade commander.

680. Whenever the colonel faces the line to give commands the majors face at the same time; they resume their front after seeing the movement executed. All such commands are executed when they have been repeated by the majors. When the command repeated is *present arms*, the colonel's staff salute at the command of the colonel; the colonel and majors salute after resuming their front. The same rules apply to the colonels and majors, and to the general's and colonel's staff when the brigade commander gives commands.

681. When the general or colonel faces the line to give commands, the staff and orderlies do not change position.

682. When the rank of the reviewing officer entitles him to the honor, each color salutes at the command *present arms*, given or repeated by the major of the battalion with which it is posted, and again in passing in review.

683. The band of each regiment plays while the reviewing officer is passing in front and in rear of the regiment.

Each band, after passing the reviewing officer, turns out of the column and takes post in front of the reviewing officer, continues to play until its regiment has passed, then ceases playing and follows in rear of its regiment; the band of the next following regiment then commences.

While marching in review, but one band in each brigade plays at a time, and but one band at a time when within one hundred paces of the reviewing officer.

684. When the color salutes, in formations for review, the march, flourishes, or ruffles are sounded by

all the field music; in passing in review, by the field music with the band that is halted in front of the reviewing officer.

685. The formation for review may be modified to suit the ground, and the present in line and the ride around the line by the reviewing officer may be dispensed with; the troops march in review with the guide either right or left, according as the post of the reviewing officer is on the right or left of the column; the officers and non-commissioned officers who have designated places on a flank of the column when the guide is right are on the opposite flank when the guide is left; in the latter case, commanders and their staffs turning out of the column take post as prescribed, but to the *left* of the reviewing officer.

686. Except in the review of a single battalion, the troops pass in review in quick time only.

687. In reviews of divisions and corps, each battalion, after its rear has passed the reviewing officer fifty paces, takes the double time for one hundred paces, in order not to interfere with the march of the column in rear.

688. The troops, having passed the reviewing officer, return to their camps by the most practicable route, being careful not to delay the march of the troops in rear of them.

BATTALION REVIEW.

689. The reviewing officer takes his post.

690. The battalion being in line, at order arms, the major, in front of and facing the center, commands: 1. *Prepare for review*, 2. *Open ranks*, 3. **MARCH**, 4. **FRONT**.

Ranks being opened, the major takes post facing to the front, twenty paces in front of the center of the battalion. The reviewing officer moves a few paces toward the major and halts, when the major turns about and commands: 1. *Carry*, 2. **ARMS**, 3. *Present*, 4. **ARMS**.

Should the rank of the reviewing officer entitle him to the honor, the color salutes as arms are presented, and the band or field music sounds the march, flourishes, or ruffles (Pars. 422 to 427, A. R., 1889). Arms having been presented, the major turns about and salutes.

The reviewing officer returns the salute, after which the major turns about and brings the battalion to order arms, turns again to the front, and returns sword. The reviewing officer now starts for the right of the line; the major joins him, salutes, and, taking post on his right, accompanies him around the battalion. The reviewing officer proceeds to the right of the band, passes in front of the company officers to the left of the line and returns to the right, passing in rear of the file closers.

While the reviewing officer is going around the battalion, the band plays, ceasing when he leaves the right to return to his post. On leaving the right of the line, the major takes his place on the left of the reviewing officer, accompanies him a few paces, salutes, moves directly to his post in front of the battalion, faces it, draws sword, and commands: 1. *Close ranks*, 2. **MARCH**, 3. *Companies right*, 4. **MARCH**.

The staff, non-commissioned staff, and band take their places (Pars. 255 and 256).

691. The column being formed, the major commands : 1. *Pass in review*, 2. *Forward*, 3. *Guide right*, 4. **MARCH**.

The column moves off, the band playing ; the column changes direction, without command from the major, at the points indicated ; the major takes his post, six paces in front of the staff, immediately after the second change ; each company is brought to the carry at the point indicated ; the band having passed the reviewing officer, turns to the left out of the column, takes post in front of and facing the reviewing officer, and remains there until the review terminates.

692. The major and staff, except the adjutant, salute together when the major is at six paces from the reviewing officer, and return to the carry together when the major has marched six paces beyond him ; the other officers, the non-commissioned staff, the drum major, and non-commissioned officers in command of subdivisions, salute and return to the carry at the points prescribed for the major ; in saluting, they turn the head and look toward the reviewing officer. Staff and non-commissioned staff officers without swords salute with the hand. If the reviewing officer be entitled to a salute from the color, the color salutes when at six paces from him, and is raised when at six paces beyond him ; as the color salutes, the field music sounds the march, flourishes, or ruffles, the band continuing to play.

The reviewing officer returns only the salute of the major and the color ; he salutes the color by uncovering.

693. The major, having saluted, takes post on the right of the reviewing officer, remains there till the rear of the battalion has passed, and then rejoins his battalion. The band ceases to play when the column has completed its first change of direction after passing the reviewing officer.

694. When the battalion arrives at its original position in column, the major commands : 1. *Double time*, 2. **MARCH**.

The band plays in double time.

The battalion passes in review as before, except that, in double time, there is no saluting and pieces remain at the right shoulder.

The review terminates when the rear company has passed the reviewing officer; the band then ceases to play, and, unless otherwise directed by the major, returns to the position it occupied before marching in review, or is dismissed; the major rejoins the battalion and may order *quick time*. The battalion then executes such movements as the reviewing officer may have directed, or is marched to its parade ground and dismissed.

695. Marching past in double time may, in the discretion of the reviewing officer, be omitted; the review then terminates as before.

696. When desirable that a battalion should be reviewed before an inspector junior in rank to the commanding officer, the commanding officer will receive the review, and will be accompanied by the inspector.

REGIMENTAL REVIEW.

697. The regiment is formed in line, in line of platoon columns at close interval, or in line of masses.

In Line.

698. The regiment having been formed in line, the colonel takes his post facing to the front; the adjutant, during the review, is on the right of the staff.

When the reviewing officer approaches his post, the colonel faces the regiment and commands: 1. *Prepare for review*, 2. *Open ranks*, 3. MARCH.

Ranks having been opened, the colonel faces to the front.

The reviewing officer, accompanied by his staff, then approaches the colonel, halting at thirty paces in front of him.

The colonel then faces the regiment, and commands: 1. *Carry*, 2. ARMS, 3. *Present*, 4. ARMS, faces to the front and salutes.

The staff salute and return to the carry at the command of the colonel.

The reviewing officer having returned the salute, the colonel brings the regiment to order arms; the colonel and his staff return sword; the colonel joins the reviewing officer, salutes and places himself on his right. The colonel's staff place themselves on the right of the staff of the reviewing officer, unless the reviewing officer advances alone, in which case the colonel alone joins and accompanies him, the staffs remaining at their posts.

The reviewing officer then goes to the right of the line, passes in rear of the line of majors to the left, and returns in rear of the file closers to the right, whence he proceeds to his post.

While the reviewing officer is passing around the regiment, the band plays.

When the reviewing officer leaves the right of the line, after passing around the regiment, the colonel salutes, returns by the shortest line to his post facing the regiment, and draws sword; the colonel's staff take post at the same time, in rear of the colonel, and draw sword.

The colonel commands: 1. *Close ranks*, 2. **MARCH**, 3. *Companies right*, 4. **MARCH**.

The column having been formed, each major takes post six paces in front of his staff; the lieutenant-colonel six paces to the right of the column, abreast of the major of the first battalion.

The colonel then commands: 1. *Pass in review*, 2. *Forward*, 3. *Guide right*, 4. **MARCH**.

The column passes in review in quick time, according to the principles prescribed for the battalion review. When the head of the column has made its second change of direction, the colonel places himself twenty-four paces in front of the band.

699. The colonel having saluted, places himself on the right of the reviewing officer. The majors do not turn out of the column after passing the reviewing officer.

700. The rear of the column having passed the reviewing officer, the battalions, unless otherwise directed, are marched to their parade grounds and dismissed.

In Line of Platoon Columns, at Close Interval.

701. With the following modifications, the rules for the review of the regiment in line apply:—

Ranks are not opened. The colonel commands: *Prepare for review*, and faces to the front.

When the reviewing officer has passed around the regiment, the colonel commands: 1. *platoons right*, 2. **MARCH**.

The column having been formed, the colonel com-

mands: 1. *Pass in review*, 2. *Take full distance*, 3. *Guide right*, 4. **MARCH**.

The leading company moves off at the command *march*, followed by the others in succession when at full distance.

Each major takes post six paces in front of his staff when his companies have full distance.

In Line of Masses.

702. The same rules apply as for the review of the regiment in line of platoon columns at close interval, except that to form column for passing in review, the colonel commands: 1. *Battalions*, 2. *Change direction by the left flank*, 3. **MARCH**.

BRIGADE REVIEW.

703. The brigade is formed in line of masses, with an interval of sixty paces between regiments. The brigade commander takes post thirty paces in front of the center of the line of colonels.

The brigade having been formed and the reviewing officer having approached within thirty paces, the brigade commander faces the brigade and commands: 1. *Carry*, 2. ARMS, 3. *Presents*, 4. ARMS, then faces to the front and salutes.

The reviewing officer having returned the salute, the brigade commander faces the brigade, commands: 1. *Carry*, 2. ARMS, 3. *Order*, 4. ARMS, then returns sword and joins the reviewing officer.

The reviewing officer, accompanied by his staff and the brigade commander and his staff, then proceeds to the right of the brigade, passing in front of the colonel of the first regiment, to the right of the line, thence around the brigade, passing to the left in rear of the majors, and to the right in rear of the file closers.

704. The colonels remain at their posts facing to the front while the reviewing officer is passing around the brigade. When the reviewing officer leaves the right of the line, the brigade commander returns by the shortest line to his post, faces the brigade and commands: 1. *Battalions*, 2. *Change direction by the left flank*, 3. MARCH.

The column having been formed, the brigade commander commands: 1. *Pass in review*, 2. *Take full distance*, 3. *Guide right*, 4. MARCH.

The column moves off as in regimental review.

705. Each colonel takes post twenty-four paces in front of the band of his regiment when the head of his regiment has made its second change of direction.

The brigade commander takes post twenty-four paces in front of the leading colonel when at one hundred paces from the reviewing officer.

The brigade commander and colonels, when they have saluted the reviewing officer, turn out of the column and take post on his right.

The review terminates when the last battalion has passed the reviewing officer.

DIVISION REVIEW.

706. The division is formed in one, two, or three lines of masses.

Upon the arrival of the reviewing officer, the general commanding the division joins and accompanies him, and causes the signal *attention* to be sounded, which is taken up in the right brigade of the first line.

In One Line.

707. The reviewing officer receives the salute of each brigade when he arrives at its right, except when he approaches a brigade from its left or front, in which case he receives the salute as prescribed in the Brigade Review.

The reviewing officer receives the salute of the right brigade, passes along its front from right to left, then receives the salute of the next brigade and so on to the left of the division, thence in rear of the division to the right, and back to his post.

Each brigade commander salutes, facing to the front, then faces his brigade and brings it to order arms, and remains at his post.

The reviewing officer having passed around the division, the general commanding the division causes the signal *attention* to be sounded.

The commander of the right brigade then forms his brigade in column, and, when the signal *forward* is sounded, gives the commands for passing in review as in the Brigade Review.

Each of the other brigades is called to attention, formed in column and put in march in time to follow the next preceding at a distance of about one hundred paces.

The division commander, with his staff, flag, and or-

derlies, takes post twenty-four paces in front of the commander of the leading brigade.

The review terminates as prescribed in the Brigade Review.

In Two or Three Lines.

708. The reviewing officer passes around each line in succession, beginning with the right brigade of the first line.

With this exception, the rules prescribed for the single line apply.

CORPS REVIEW.

709. The corps is formed in one, two, or three lines, with each division in a single line of masses.

On the arrival of the reviewing officer, the corps commander causes the *attention* to be sounded, which is repeated by the trumpeter of the commander of the right division of the first line, and is taken up in the right brigade of that division.

The reviewing officer passes in front of the first line from right to left, receiving the salute of each brigade as prescribed in the Division Review, passes in rear of the line to its right, thence to the second line, passing around it in like manner, and so on.

Each division commander, accompanied by his staff, joins the reviewing officer and corps commander as they approach his division, and accompanies them while passing in front and in rear of his division; he then remains near the right of his division.

The reviewing officer having passed around the troops, the corps commander causes the *attention* and *forward* to be sounded; the march in review is conducted on the same principles as for the review of a division.

On approaching the reviewing officer, the general commanding the corps places himself about twenty-four paces in front of the general of the first division; his staff place themselves six paces in rear of him, the flag and orderlies three paces in rear of the staff.

710. The artillery of the corps is reviewed as prescribed in the Drill Regulations for Artillery.

711. The review of a command larger than a corps is conducted on the same principles, or the troops may be marched in review in column of masses.

GUARD MOUNTING.

712. At the *assembly* the men warned for duty fall in on their company parade grounds, facing to the front, non-commissioned officers and supernumeraries falling in as file closers; each first sergeant then verifies his detail, opens ranks, inspects the dress and general appearance, replaces by a supernumerary any man unfit to march on guard, and then closes ranks.

The band takes post on the parade, so that the left of its front rank shall be twelve paces to the right of the front rank of the guard when the latter is formed.

713. At *adjutant's call*, the adjutant, dismounted, proceeds to the parade ground and takes post so as to be twelve paces in front of and facing the center of the guard when formed; the sergeant major reports to the adjutant and takes post facing to the left, twelve paces to the left of the front rank of the band; the band plays in quick or double time; the details are marched to the parade ground by the first sergeants, with arms at the right shoulder; the detail that arrives first is so marched to the line that, upon halting, the breast of the right front rank man shall be near to and opposite the left arm of the sergeant major; the first sergeant brings his piece to a carry, halts his detail, places himself in front of and facing the sergeant major, at a distance equal to or a little greater than the front of his detail; he then commands: 1. *Right*, 2. **DRESS**. The detail dresses up to the line of the sergeant major and first sergeant, the right front rank man placing his breast against the left arm of the sergeant major; the non-commissioned officers take post two paces, and the supernumerary nine paces, in rear of the rear rank of the detail. Seeing the detail aligned, the first sergeant commands: **FRONT**, salute, and then reports: *The de-*

tail is correct ; or, (so many) *sergeants, corporals, or privates are absent* ; the sergeant major or acting sergeant major returns the salute with the right hand after the report is made; the first sergeant then passes by the right of the guard and takes post three paces in rear of his supernumerary, at the order.

Each of the other details is formed in like manner on the left of the one preceding; the men, non-commissioned officers, supernumerary, and first sergeant of each detail dress on those of the preceding details in the same rank or line; each first sergeant closes the rear rank to the right and fills blank files, as far as practicable, with men from his front rank.

The company details alternate in taking the right of the line.

714. When the last detail has formed, the sergeant major draws sword, verifies the detail, causes the guard to count fours, completing the left four, if necessary, as in the School of the Company, and if there be more than three fours, divides the guard into two platoons, after which he commands : 1. *Open ranks*, 2. **MARCH**. †

At the command *march*, the rear rank steps back and halts three paces in rear of the front rank; the non-commissioned officers three paces in rear of the rear rank; all dress to the right. The sergeant major verifies the alignment of the ranks, file closers, supernumeraries, and first sergeants, and then returns to the right of the front rank, faces to the left, commands : 3. **FRONT**, passes to a point midway between the adjutant and the center of the guard, halts facing the adjutant, salutes and reports : *Sir, the details are correct* ; or, *Sir, (so many) sergeants, corporals, or privates are absent* ; the adjutant returns the salute, directs the sergeant major : *Take your post*, and then draws sword; the sergeant major faces about and takes post facing to the front, three paces to the left of the front rank. When the sergeant major has reported, the officer of the

guard takes post, facing to the front, three paces in front of the center of the guard, and draws sword.

715. The adjutant then commands : 1. *Officer (or officers) and non-commissioned officers, front and center,* 2. **MARCH.**

The officer advances and halts three paces from the adjutant ; the non-commissioned officers carry arms, pass by the flanks, and moving by the shortest line form in the order of rank, from right to left, three paces in rear of the officer ; the adjutant then assigns the officer and non-commissioned officers according to rank, as follows : *Commander of the guard, chief of first platoon, chief of second platoon, right guide of first platoon, left guide of second platoon, left guide of first platoon, right guide of second platoon and file closers.*

The adjutant then commands : 1. *Non-commissioned officers ;* or, 1. *Officer and non-commissioned officers,* 2. **POSTS,** 3. **MARCH.**

At the command *march*, all, except the officer commanding the guard, face about and take the posts prescribed in the School of the Company with open ranks, and order arms. The adjutant then directs : *Inspect your guard, sir ;* at which the officer commanding the guard faces about, commands : 1. *Inspection,* 2. **ARMS,** returns sword and inspects the guard.

716. During the inspection the band plays.

The adjutant, during the inspection, returns sword, observes the general condition of the guard, and replaces by the supernumerary any man who does not present a creditable appearance. He also, when so directed, selects an orderly for the commanding officer, and notifies the commander of the guard of his selection.

717. If there be a supernumerary officer of the guard, he takes post facing to the front, three paces in front of the center of the first platoon ; in going to the front and center he closes on the senior and is assigned as chief of

the first platoon ; he may be directed by the commander of the guard to assist in inspecting the guard.

718. If there be no officer of the guard the adjutant inspects the guard. The non-commissioned officer commanding the guard takes post on the right of the right guide, when the guard is in line ; and takes the post of the officer commanding the guard, when in column or passing in review.

719. The inspection ended, the adjutant places himself about thirty paces in front of and facing the center of the guard, and draws sword ; the officers of the day take post in front of and facing the guard, about thirty paces from the adjutant ; the old officer of the day three paces to the right of and one pace to the rear of the new officer of the day ; the officer commanding the guard takes post three paces in front of its center, and draws sword ; thereafter he takes the same relative positions as a captain of a company.

The adjutant then commands : 1 *Parade*, 2. REST, 3. SOUND OFF.

The band, playing, passes in front of the officer of the guard to the left of the line, and back to its post on the right, when it ceases playing.

The adjutant then commands : 1. *Guard*, 2. ATTENTION, 3. *Carry*, 4. ARMS, 5 *Close ranks*, 6. MARCH.

The ranks are closed as in the School of the Company.

720. The adjutant then commands : 1. *Present*, 2. ARMS, faces toward the new officer of the day, salutes, and then reports : *Sir, the guard is formed*. The new officer of the day, after the adjutant has reported, returns the salute with the hand and directs the adjutant : *March the guard in review, sir*.

The adjutant faces about, brings the guard to a carry, and commands : 1. *Platoons right*, 2. MARCH.

The platoons execute the movement ; the band turns to the right and places itself twelve paces in front of the first platoon.

The adjutant places himself abreast of the first platoon and six paces from its left flank; the sergeant major, six paces from the left flank of the second platoon.

The adjutant then brings the guard to the right shoulder and commands: 1. *Pass in review*, 2. *Forward*, 3. *Guide right*, 4. MARCH.

The guard marches in quick time past the officer of the day, according to the principles of review, and is brought to the carry at the proper time by the commander of the guard; the adjutant, commander of the guard, chiefs of platoons, sergeant major, and drum major salute.

The band, having passed the officer of the day, turns to the left out of the column, places itself opposite and facing them, and ceases to play when the rear of the column has passed; the field music detaches itself from the band when the latter turns out of the column, and, remaining in front of the guard, commences to play when the band ceases. In the absence of the band, the field music does not turn out of the column but continues in front of the guard.

The guard having passed the officer of the day, the adjutant halts; the sergeant major halts abreast of the adjutant and one pace to his left; they then return sword and retire.

721. The commander of the guard forms it into column of fours, without halting, and marches it to its post.

722. The officers of the day face toward each other and salute, the old officer of the day turning over the orders to the new officer of the day.

While the band is sounding off, and while the guard is marching in review, the officers of the day stand at parade rest with arms folded, and come to attention before the guard is to be presented, and again as the head of the column approaches.

The new officer of the day returns only the salute of the commander of the guard and the adjutant, making one salute with the hand.

723. The first sergeants and supernumeraries come to parade rest and attention with the guard ; they remain at order arms while the guard is being presented and formed into column. The senior first sergeant commands : 1. *Parade*, 2. **REST**, at the command *march* for passing in review, and : 1. *Supernumeraries*, 2. **ATTENTION**, when the officers of the day come to attention.

The first sergeants come to parade rest, and to attention with the supernumeraries. The rear of the column having passed the officers of the day, each first sergeant marches his supernumerary to the company parade and dismisses him.

724. If the guard be not divided into platoons, the adjutant commands : 1. *Guard right*, 2. **MARCH**, and it passes in review as above ; the commander of the guard is two paces in front of its center ; the adjutant is six paces from and abreast of its left flank ; the sergeant major covers the adjutant on a line with the file closers.

725. The officer of the day may direct the adjutant : *March the guard to its post, sir*. The adjutant faces about and commands : 1. *Guard to its post*, 2. *Fours right*, 3. **MARCH** ; or, 3. *Double time*, 4. **MARCH**.

The guard wheels by fours to the right ; the field music takes post in front ; the adjutant and sergeant major return sword and retire ; the first sergeants march off their supernumeraries ; the officers of the day salute each other, and the band retires.

726. As the new guard approaches the guard house, the old guard is formed in line at the carry, with its field music two paces to its right ; and, when the field music at the head of the new guard arrives opposite its left, the commander of the old guard commands : 1. *Present*, 2. **ARMS** ; and commands : 1. *Carry*, 2. **ARMS**, when the new guard has passed.

The new guard marches in quick time past the old guard, arms at a carry, commanders of both guards saluting.

The field music having marched three paces beyond the field music of the old guard, changes direction to the right, and, followed by the guard, changes direction to the left, when on a line with the old guard; the changes of direction are without command. The senior officer of the guard halts on the line of the front rank of the old guard, allows his guard to march past him, and, when its rear approaches, wheels it by fours to the left, halts it, establishes the left guide three paces to the right of the field music of the old guard, and on a line with the front rank, and then dresses his guard to the left; the field music with the new guard is two paces to the right of its front rank.

The new guard being dressed, the commander of each guard, in front of and facing its center, commands: 1. *Present*, 2. **ARMS**, resumes his front and salutes.

The commanders having saluted, face their guards and command: 1. *Carry*, 2. **ARMS**, 3. *Order*, 4. **ARMS**.

727. Should a guard be commanded by a non-commissioned officer, he presents arms with his guard, standing on the right or left of the front rank, according as he commands the old or new guard.

728. The detachments and sentinels of the old guard are relieved, and, as they come in, form on its left; both guards are brought to a carry; the commander of the old guard then marches it, with the guide right, six paces to the front, when he commands: 1. *Fours right*, 2. **MARCH**.

The guard wheels by fours to the right, the field music begins to play and the guard marches in quick time past the new guard, which stands at present arms, commanders of both guards saluting.

729. On arriving on the regimental, post, or camp parade, the commander of the old guard forms it in line and halts it, opens chamber (Par. 83), orders successively the company details two paces to the front, and sends each, under charge of a non-commissioned officer or private, to its company.

730. In bad weather, at night, or after long marches, the music may be dispensed with, or the field music may take the place of the band and sound off, standing on the right of the guard, and the review be omitted.

731. When dismounted cavalry and infantry are united for guard mounting, the cavalry details retain their single rank formation. The cavalry non-commissioned officers and supernumeraries place themselves in line with those of the infantry.

732. For detailed instructions not herein' prescribed, see Manual of Guard Duty.

BATTALION PARADE.

733. At the *assembly*, the companies form under arms on their respective parade grounds, and are inspected by their captains; the inspection being completed, *adjutant's call* is sounded, at which the line is formed on the battalion parade ground.

The major takes post at a convenient distance in front of the center, facing the line.

At the command *guides posts*, the sergeant major takes post as in open ranks.

The adjutant, having commanded: *Guides posts*, directs the first captain to bring his company to *parade rest*. The captains, commencing on the right, successively face about and command: 1. (Such) *Company*, 2. *Parade*, 3. **REST**, resume their front, and take the position of parade rest; the adjutant takes post three paces to the right of the battalion, in line with the captains, commands: **SOUND OFF**, and, if dismounted, takes the position of parade rest.

The band, playing in quick time, passes in front of the captains, to the left of the line, and back to its post on the right, when it ceases playing. At evening parade, when the band ceases playing, *retreat* is sounded by the field music.

The major, if dismounted, stands at parade rest with arms folded while the band is playing, and resumes attention when arms are about to be presented. When the music ceases, the adjutant faces to the left, and commands: 1. *Battalion*, 2. **ATTENTION**, 3. *Open ranks*.

He aligns the guides for the rear rank, returns to the line of captains, faces to the left, and commands: 4. **MARCH**.

He verifies the alignment of the officers, the ranks and the file closers, returns to the line of captains, faces

to the left, commands : **FRONT**, then moves at a trot or gallop (if dismounted, in quick time) by the shortest line to a point midway between the major and the center of the battalion, halts, faces the battalion and commands : 1. *Carry*, 2. **ARMS**, 3. *Present*, 4. **ARMS**. He then turns about, salutes the major, and reports : *Sir, the parade is formed*. The major returns the salute and directs the adjutant : *Take your post, sir*. The adjutant moves at a trot or gallop (if dismounted, in quick time), passes by the major's right, and takes post facing the battalion, three paces to the left of the major and one pace less advanced.

The adjutant having taken his post, the major draws sword, commands : 1. *Carry*, 2. **ARMS**, and adds such exercises in the manual of arms as he may desire, concluding with order arms. The officers and color guard, having once executed order arms, remain in that position during the exercise in the manual.

The major then directs the adjutant : *Receive the reports, sir*, and returns sword. The adjutant, passing by the major's left, advances at a trot or gallop (if dismounted, in quick time) toward the center of the line, halts midway between it and the major, and commands : 1. *First sergeants*, 2. *Front and center*, 3. **MARCH** ; or, 3. *Double time*, 4. **MARCH**.

At the first command, the first sergeants carry arms.

At the second command, each marches two paces in front of and opposite the right of his company and faces toward the center ; the drum major at the same time faces to the left.

At the command *march*, the first sergeants and drum major march to the center, and successively face to the front ; the adjutant then commands : *Report*.

The drum major and the first sergeants, commencing on the right, successively salute and report : the drum major, *band and field music present or accounted for* ; or, (so many) *musicians* or *field musicians absent* ; the

first sergeants, *Company* ("A," etc.) *present or accounted for*; or, (so many) *sergeants, corporals, or privates absent*.

The reports having been made, the adjutant commands: 1. *First sergeants*, 2. *Posts*, 3. **MARCH**; or, 3. *Double time*, 4. **MARCH**.

At the command *posts*, the first sergeants and drum major face outward.

At the command *march*, they resume their posts and order arms; each first sergeant passes around the right flank of his company.

The adjutant then turns about, salutes, and reports: *Sir, all are present or accounted for*; or, *Sir*, (so many) *officers or enlisted men are absent*. The major returns the salute and directs: *Publish the orders, sir*.

The adjutant turns about and commands: *Attention to orders*; he then reads the orders, and commands: 1. *Officers*, 2. *Center*, 3. **MARCH**.

At the command *officers*, all the officers except the adjutant return sword.

At the command *center*, the company officers face to the center.

At the command *march*, the company officers close to the center and face to the front; the adjutant returns sword, turns about and takes post with the major as previously prescribed; the staff officers ride toward the major at a trot and take post one pace to the left of the adjutant, facing the battalion one pace apart, in the order of rank from right to left, senior on the right; if dismounted, they face and close in with the company officers.

The officers having closed and faced to the front, the senior company officer commands: 1. *Forward*, 2. *Guide center*, 3. **MARCH**. The officers advance, the band playing; the left officer of the right wing is the guide, and marches on the major; at six paces from the major the senior company officer commands: 1. *Officers*, 2. **HALT**.

The music ceases; the officers halt and salute, keep the hand at the visor till the salute is returned, and drop it at the same time with the major. The major then gives such instructions as he may deem necessary, and this concludes the ceremony.

As the officers disperse, the music is resumed; each first sergeant moves in front of his company, closes ranks, marches it to its parade ground and dismisses it; the band plays till the companies leave the parade ground.

734. The commanding officer may direct that the first sergeants march their companies, in line, or in column of platoons, around the parade ground, changing direction and saluting as in passing in review; after passing the major, they march them to their company parade grounds and dismiss them. Or, he may direct that the companies move off in echelon, and march to their parade grounds. In these cases the officers remain with the major until all the companies have passed.

REGIMENTAL PARADE.

735. The regiment is formed in line, in line of platoon columns at close interval, or in line of masses.

In Line.

736. At the *assembly*, the companies are formed and inspected.

At *adjutant's call*, each battalion is formed in line; the battalion adjutant having taken his post in front of the center, before presenting the battalion to the major, receives the reports of the first sergeants as prescribed in battalion parade.

737. When the battalions are formed, *adjutant's call* is again sounded; the regiment is then formed in line, each major opening ranks in his battalion as soon as it is formed on the line, regulating on the base battalion.

The adjutant, after indicating the position of the point of rest, takes post facing to the left, six paces to the right of the post of the lieutenant-colonel (Par. 369); when the line is formed, he directs the first major to bring his battalion to parade rest.

The majors, in succession, bring their battalions to parade rest.

The adjutant then turns to his left and commands: **SOUND OFF**, and takes post, facing to the front, six paces to the right of the post of the lieutenant-colonel.

The band, playing in quick time, passes in front of the adjutant and field officers, to the left of the regiment, and back to its post on the right, when it ceases playing.

The adjutant then moves by the shortest line, at a trot or gallop, to a point midway between the colonel

and the center of the regiment, faces the regiment, and commands: 1. *Battalions*, 2. ATTENTION, 3. *Carry*, 4. ARMS, 5. *Present*, 6. ARMS, faces the colonel, salutes, and reports: *Sir, the parade is formed.*

The colonel returns the salute and directs the adjutant: *Take your post, sir.* The adjutant takes his post three paces to the left of the colonel and one pace less advanced, passing by his right and rear.

The colonel and staff officers draw sword; the colonel then commands: 1. *Carry*, 2. ARMS, and adds such exercises in the manual as he may desire, concluding with *order arms.*

The colonel then directs the adjutant to receive the reports and returns sword; his staff return sword at the same time.

The adjutant advances by the left of the colonel toward the line, halts midway between the colonel and the center of the regiment, and commands: 1. *Adjutants*, 2. *Front and center*, 3. MARCH; or, 3. *Trot*, 4. MARCH.

At the command *march*, the battalion adjutants move six paces in front of the line of company officers, close to the center and face to the front. The adjutant then commands: *Report*, when the battalion adjutants, commencing on the right, salute and report: (Such) *battalion present or accounted for*; or, (Such) *battalion (so many) officers and enlisted men are absent.* The adjutant then commands: 1. *Adjutants*, 2. *Post*, 3. MARCH; or, 3. *Trot*, 4. MARCH. The battalion adjutants, moving by the shortest lines, then take post in the line of field officers, each three paces to the left of the major of his battalion. The adjutant then faces the colonel, salutes and reports: *Sir, all are present or accounted for*; or, *Sir, (so many) officers and enlisted men are absent.* The colonel returns the salute and directs: *Publish the orders, sir.* The adjutant faces the regiment, and, after publishing the orders, commands:

1. *Officers*, 2. *Center*, 3. **MARCH**, returns sword and takes post on the left of the lieutenant-colonel.

At the command *officers*, all the officers, except the adjutant, return sword.

At the command *center*, the company officers face toward the center.

At the command *march*, the company officers close to the center and face to the front.

The field officers and adjutants moving to the right and left, on their own line, uncover the line of company officers and form in the following order from right to left:—

The lieutenant-colonel, adjutant, major of the first battalion and his adjutant, six paces to the right of the line of company officers; the major of the second battalion, his adjutant, the major of the third battalion and his adjutant, six paces to the left of the company officers.

The company officers having closed and faced to the front, the senior captain commands: 1. *Forward*, 2. *Guide center*, 3. **MARCH**.

The company officers advance, the band playing; the left officer of the right wing of the second battalion, or the left officer, first battalion, if there be but two battalions, is the guide and marches on the colonel.

When the company officers have advanced six paces beyond the line of field officers, the field officers and adjutants advance, thus forming in echelon on the right and left of the company officers.

The lieutenant-colonel commands: 1. *Officers*, 2. **HALT**, when the company officers are six paces from the colonel; the ceremony concludes as in the battalion parade.

The lieutenant-colonel and adjutant join the colonel; all the other officers rejoin their battalions; the battalions are marched to their parade grounds and dismissed.

In Line of Platoon Columns or in Line of Masses.

738. The line is formed as prescribed in the Evolutions of the Regiment.

Ranks are not opened.

After publishing the orders the adjutant commands :

1. *Field officers*, 2. *Center*, 3. **MARCH**.

The field officers and adjutants return swords, close on the second major, face to the front, and the lieutenant colonel commands : 1. *Forward*, 2. *Guide center*, 3. **MARCH**.

The second major is the guide and marches on the colonel.

The company officers remain at their posts with their companies.

With these exceptions the same rules apply as in the regimental parade in line.

BATTALION INSPECTION.

739. If there be both inspection and review, the inspection may either precede or follow the review.

The battalion being in column of companies at full distance, all officers dismounted, the major commands :

1. *Prepare for inspection*, 2. **MARCH**.

At the first command, each captain commands : *Open ranks*.

At the command *march*, the ranks are opened in each company, as explained in the School of the Company.

The field musicians join their companies.

The drum major conducts the band, if not already there, to its position in rear of the column, and opens ranks.

The staff officers form a line equal to the front of the column, fifteen paces in front of the leading company, the adjutant on the right, the others in the order of rank from right to left, the senior next to the adjutant; the non-commissioned staff form in a similar manner, three paces in rear of the staff officers, the sergeant major on the right; the color guard in one rank marches to the front and takes post three paces in rear of the center of the line of non-commissioned staff.

The major takes post in front of the center of the column, six paces in front of the staff.

740. Field and staff officers senior in rank to the inspector do not take post in front of the column, but accompany him.

After inspecting the major and staff officers, the inspector, accompanied by these officers, passes down the open column, looking at the front and rear of each rank. The major and staff return sword as soon as inspected.

The major now commands: **REST**.

741. The inspector, commencing at the head of the column, makes a minute inspection of the non-commissioned staff, color guard, and the arms, accouterments, dress and ammunition of each soldier of the several companies in succession, and inspects the band.

The adjutant gives the necessary commands for the inspection of the non-commissioned staff, color guard and band.

The non-commissioned staff and color guard may be dismissed as soon as inspected.

742. As the inspector approaches each company, its captain commands: 1. *Company*, 2. ATTENTION, 3. *Inspection*, 4. ARMS, and faces to the front; as soon as inspected, he returns sword and accompanies the inspector.

At the command *arms*, the lieutenants carry sword, and, when the inspector begins the inspection of the front rank, face about and stand *at ease*, swords at the order; upon the completion of the inspection of arms and ammunition, they come to attention, carry sword, face about and order sword.

The company then closes ranks (the captain may direct the lieutenants to retain their places in front of the company), stacks arms and open ranks.

The captain then commands: 1. *Unslung*, 2. KNAPSACK, 3. *Open*, 4. KNAPSACK.

The first and second commands are executed as in Par. 98, except that the rear rank stands fast and each man places his knapsack on the ground at his feet.

At the fourth command the knapsacks are opened.

The inspection completed, the captain commands: 1. *Close*, 2. KNAPSACK, 3. *Sling*, 4. KNAPSACK.

At the second command, each man repacks and closes his knapsack and then stands erect, leaving the knapsack on the ground.

At the fourth command, knapsacks are slung as in Par. 98, the rear rank standing fast.

Ranks are closed, arms taken, and, on intimation from the inspector, the captain marches the company to its quarters and dismisses it.

In a long column, some of the rearmost companies, after the inspection of dress and general appearance, may be permitted to stack arms and fall out ; before the inspector approaches, they take arms and resume their positions.

The band plays during the inspection of the companies.

743. When the inspector approaches the band, the adjutant commands : 1. *Inspection*, 2. **INSTRUMENTS**.

Each man as the inspector approaches him raises his instrument in front of the body, reverses it so as to show both sides, and then returns it to its former position.

744. The inspection of dress and general appearance may be dispensed with on intimation of the inspector, the battalion being brought to a rest as soon as the major and staff have been inspected.

745. At inspection of quarters, the inspector is accompanied by all the officers, or by such of them as he may designate ; the men, without accouterments, stand uncovered in front of their respective bunks ; in camp, they stand, covered, without accouterments, in front of their tents ; the senior non-commissioned officer, upon the approach of the inspector, commands : 1. *Company* (or *squad*), 2. **ATTENTION**.

The men come to attention and do not salute ; in camp, the non-commissioned officer salutes.

COMPANY INSPECTION.

746. Captains inspecting their companies on their own parade grounds, use the commands and means prescribed for the company at battalion inspection.

INSPECTION OF A COMPANY ON ITS OWN PARADE.

747. Should the inspector be other than the captain, the captain opens ranks, takes his post in front of the right of the company, and, when the inspector approaches, salutes.

The inspection is made as before (Par. 742).

REGIMENTAL INSPECTION.

748. The commands and means are the same as prescribed for a battalion.

The staff officers of the colonel form a line equal to the front of the column, fifteen paces in front of the major of the first battalion, the adjutant on the right, the others in the order of rank from right to left, the senior next the adjutant; the non-commissioned staff form in a similar manner three paces in rear of the staff officers, the sergeant major on the right; the color guard takes post three paces in rear of the center of the line of non-commissioned staff.

The colonel takes post opposite the center of the column, six paces in front of his staff, the lieutenant-colonel four paces to his left. The colonel, lieutenant-colonel, and staff officers, as soon as inspected, return sword and accompany the inspector, who inspects the dress and general appearance of the regiment.

The adjutant brings the non-commissioned staff and color guard to rest as soon as the inspector passes them.

749. Each major remaining at his post, brings his battalion to a rest as soon as the inspector leaves it.

The inspector, after passing to the rear of the regiment, commences again at the head of the column and minutely inspects the non-commissioned staff, the color guard, and the non-commissioned staff and companies of each battalion.

750. Each major, with his staff officers, accompanies the inspector through his battalion, after which he marches his battalion to its parade ground and dismisses it, unless otherwise directed.

REGIMENTAL OR BATTALION MUSTER.

751. Muster is preceded by an inspection, and, when practicable, by a review.

The adjutant is provided with the muster roll of the field, staff, and band, the surgeon with the hospital roll, and each captain with the roll of his company. A list of absentees, alphabetically arranged, showing cause and place of absence, accompanies each roll.

Being in column of companies at open ranks, each captain, as the mustering officer approaches, brings his company to right shoulder arms, and commands: *Attention to muster.*

The mustering officer or captain then calls the names on the roll; each man, as his name is called, answers "Here," and brings his piece to order arms.

752. After muster, the mustering officer, accompanied by the company commanders and such other officers as he may designate, verifies the presence of the men reported in hospital, on guard, etc.

753. A company may be mustered in the same manner on its own parade ground, the muster to follow the inspection prescribed in Par. 747.

ESCORT OF THE COLOR.

754. The regiment being in line, the colonel details a company, other than the color company, to receive and escort the color to its place in line.

The escort is formed in column of platoons, the band in front, the color bearer between the platoons. The escort then marches, without music, to the colonel's office or quarters, is formed in line facing the entrance and halted, the band on the right, the color bearer in the line of file closers.

The color bearer, preceded by the first lieutenant and followed by a sergeant of the escort, then goes to receive the color.

When the color bearer comes out, followed by the lieutenant and sergeant, he halts before the entrance, facing the escort; the lieutenant places himself on the right, the sergeant on the left of the color bearer; the escort presents arms, and the field music sounds *to the color*.

Arms are brought to the carry; the lieutenant and sergeant return to their posts; the company executes *platoons right*, the band taking post in front of the column; the color bearer places himself between the platoons; arms are then brought to the right shoulder, and the escort marches in quick time, with guide left, back to the regiment, the band playing; the march is so conducted that when the escort arrives at fifty paces in front of the right of the regiment, the direction of the march shall be parallel to its front; when the color arrives opposite its place in line, the escort is formed in line to the left and halted; the color bearer, passing between the platoons, advances and halts twelve paces in front of the colonel.

The color bearer having halted, the colonel, who has taken post thirty paces in front of the center of his reg-

iment, faces about, commands: 1. *Carry*, 2. **ARMS**, 3. *Present*, 4. **ARMS**, resumes his front and salutes; the field music sounds *to the color*, and the color bearer returns the color salute.

The colonel then faces about, brings the regiment to a carry, after which the color bearer takes his post with the color company; the regiment is then brought to order arms.

755. The escort presents and carries arms with the regiment, at the command of the colonel, after which the captain forms it again in column of platoons, and, preceded by the band, marches it at right shoulder arms to its place in line, passing around the left flank of the regiment.

756. The band plays until the escort passes the left of the line, when it ceases playing and returns to its post on the right, passing in rear of the regiment.

The regiment may be brought to a rest when the escort passes the left of the line.

757. The color is escorted from the parade ground of the color company to the colonel's office or quarters by the color guard.

ESCORTS OF HONOR.

758. Escorts of honor are detailed for the purpose of receiving and escorting personages of high rank, civil or military. The troops for this purpose are selected for their soldierly appearance and superior discipline.

The escort forms in line, opposite the place where the personage presents himself, the band on the flank of the escort toward which it will march. On the appearance of the personage, he is received with the honors due to his rank. The escort is formed into column of companies, platoons, or fours, and takes up the march, the personage and his staff or retinue taking position in rear of the column. On leaving the escort, line is formed and the same honors are paid as before.

When the position of the escort is at a considerable distance from the point where the personage is to be received, as, for instance, where a courtyard or wharf intervenes, a double line of sentinels is posted from that point to the escort, facing inward; the sentinels successively salute as he passes, and are then relieved and join the escort.

An officer is appointed to attend him, to bear such communications as he may have to make to the commander of the escort.

FUNERAL ESCORT.

759. The composition and strength of the escort are prescribed in Pars. 474, 475, and 476, A. R., 1889. [See Appendix.]

The escort is formed opposite the tent or quarters of the deceased; the band on that flank of the escort toward which it is to march.

Upon the appearance of the coffin the commander commands: 1. *Carry*, 2. **ARMS**, 3. *Present*, 4. **ARMS**; and the band plays an appropriate air; arms are then carried, after which the coffin is taken to the flank of the escort opposite the music.

760. The escort is next formed into column of companies, platoons, or fours. If the escort be small, it may be marched in line. The procession is formed in the following order: 1. *Music*, 2. *Escort*, 3. *Clergy*, 4. *Coffin and pallbearers*, 5. *Mourners*, 6. *Members of the former command of the deceased*, 7. *Other officers and enlisted men*, 8. *Distinguished persons*, 9. *Delegations*, 10. *Societies*, 11. *Civilians*. Officers and enlisted men (Nos. 6 and 7) are with side arms in the order of rank, seniors in front.

The procession being formed, the commander of the escort puts it in march, arms at the right shoulder.

761. The escort marches slowly to solemn music; the column having arrived opposite the grave, line is formed facing it.

The coffin is then carried along the front of the escort to the grave, arms are presented, the music plays an appropriate air; the coffin having been placed over the grave, the music ceases and arms are brought to the order.

762. The commander next commands: 1. *Parade*, 2. **REST**. The escort executes *parade rest*, officers and men inclining the head to the front.

When the funeral services are completed and the coffin lowered into the grave the commander causes the escort to resume attention and fire three rounds of blank cartridges, the muzzles of the pieces being elevated.

A trumpeter then sounds *taps*.

The escort is then formed into column, marched in quick time to the point where it was assembled, and dismissed.

The band does not play until it has left the inclosure.

763. When the distance to the place of interment is considerable, the escort, after having left the camp or garrison, may march *at ease* until it approaches the burial ground, when it is called to attention. The music does not play while *at ease*.

In all funeral ceremonies, six pallbearers may be selected from the grade of the deceased, or the grades next above or below. If a commissioned officer, the coffin is borne by six non-commissioned officers: if a non-commissioned officer or private, by six privates.

764. At the funeral of a general officer, the commander of the escort, in forming column, gives the appropriate commands for the cavalry, artillery, and infantry, which form in column, from front to rear, in the order named. The field music sounds the march, flourishes, or ruffles, according to the rank of the deceased, whenever arms are presented, after which the band plays an appropriate air. In marching to the cemetery, the trumpeters of the artillery and cavalry may alternate in playing with the band of the infantry.

765. At the funeral of a mounted officer or enlisted man, his horse, in mourning caparison, follows the hearse.

766. Should the entrance to the cemetery prevent the hearse from accompanying the escort till the latter halts at the grave, the column is halted at the en-

trance long enough to take the coffin from the hearse, when the column is again put in march. The cavalry and artillery, when unable to enter the inclosure, wheel out of the column, face to the column, and salute the remains as they pass.

767. When necessary to escort the remains from the quarters of the deceased to the church before the funeral service, arms are presented upon receiving the remains at the quarters, and also as they are borne into the church.

768. The commander of the escort, previous to the funeral, gives the clergyman and pallbearers all needful directions.

TRUMPET CALLS, ETC.

WARNING CALLS.

769. *First call, guard mounting, full dress, overcoats, drill, stable, water, and boots and saddles*; they precede the *assembly* by such interval as may be prescribed by the commanding officer.

Mess, church, and fatigue, classed as service calls, may also be used as warning calls.

First call is the first signal for formation for roll call and for all ceremonies except guard mounting.

Guard mounting is the first signal for guard mounting.

The field music assemble at *first call* and *guard mounting*.

In a mixed command, *boots and saddles* is the signal to mounted troops that their formation is to be mounted; for mounted guard mounting or mounted drill it immediately follows the signal *guard mounting* or *drill*.

When full dress or overcoats are to be worn, the *full dress* or *overcoat* call immediately follows *first call, guard mounting, or boots and saddles*.

FORMATION CALLS.

Assembly: the signal for the companies or details to form on their company parade grounds.

Adjutant's call: the signal for the companies or guard details to assemble on the camp or garrison parade ground; it follows the *assembly* at such interval as may be prescribed by the commanding officer.

ALARM CALLS.

Fire call: the signal for the men to fall in, without arms, to extinguish fire.

To arms: the signal for the men to fall in, under arms, on their company parade grounds as quickly as possible.

To horse: the signal for mounted men to proceed under arms to their horses, saddle, mount, and assemble at a designated place as quickly as possible.

SERVICE CALLS.

Taps, mess, sick, church, recall, issue, officer's, first sergeant's, fatigue, school, and the general.

The *general* is the signal for striking tents and loading wagons preparatory to marching.

Reveille and *tattoo* precede the *assembly* for roll call; *retreat* follows the *assembly*, the interval between being only that required for formation and roll call, except when there is parade.

Assembly, reveille, retreat, adjutant's call, to the color, the flourishes, ruffles, and the marches are sounded by all the field music united; the other calls, as a rule, are sounded by the trumpeter of the guard or order'y trumpeter; he may also sound the *assembly* when the trumpeters are not united.

The morning gun is fired at the first note of *reveille*, or, if marches be played before *reveille*, it is fired at the commencement of the first march.

The evening gun is fired at the last note of *retreat*.

The drill signals include both the preparatory commands and the commands of execution; the last note is the command of execution.

When a command is given by the trumpet, the chiefs of subdivisions give the proper commands orally.

The memorizing of these signals will be facilitated by observing that all movements to the right are on the ascending chord, that the corresponding movements to the left are corresponding signals on the descending chord; and that the changes of gait are all upon the same note.

TRUMPET CALLS, &c.

To economise space, the music is written an octave higher than the trumpet scale, and is adjusted to the scale of the bugle.

1. FIRST CALL.

Quick.

3 3

2. GUARD MOUNTING.

Quick.

3 3

TRUMPET CALLS, ETC.

3. FULL DRESS.



4. OVERCOATS.



5. DRILL.

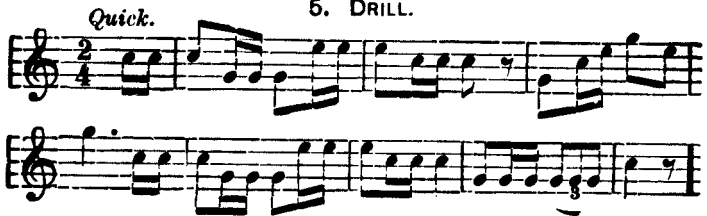

6. STABLE.



7. WATER.

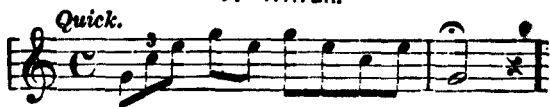

8. BOOTS AND SADDLES.



9. ASSEMBLY.



10. ADJUTANT'S CALL.



THUMPET CALLS, ETC.

11. FIRE.

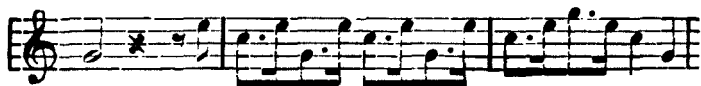

Repeat at will.



12. TO ARMS.

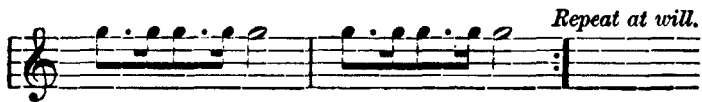
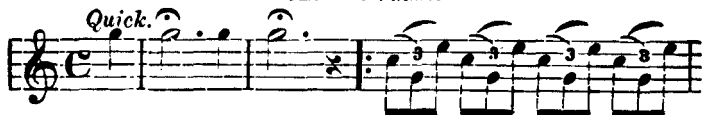

Repeat at will.

13. TO HORSE.



14. REVEILLE.

Quick.

End.

D.C.

The musical score for 'Reveille' is written in treble clef with a 2/4 time signature. It consists of ten measures. The first measure is marked 'Quick.' and contains a quarter rest followed by a quarter note G4. The subsequent measures contain eighth-note patterns: measures 2-4 are eighth-note pairs (A4-G4, B4-A4, C5-B4), and measures 5-10 are eighth-note pairs (D5-C5, B4-A4, G4-F4). The piece concludes with a double bar line, a repeat sign, and a final eighth-note pair (G4-F4) marked 'End.' and 'D.C.' (Da Capo).

15. RETREAT.

Moderate.

The musical score for 'Retreat' is written in treble clef with a 2/4 time signature. It consists of ten measures. The first measure is marked 'Moderate.' and contains a quarter rest followed by a quarter note G4. The subsequent measures contain eighth-note patterns: measures 2-4 are eighth-note pairs (A4-G4, B4-A4, C5-B4), and measures 5-10 are eighth-note pairs (D5-C5, B4-A4, G4-F4).

TRUMPET CALLS, ETC.

RETREAT—*Concluded.*

The musical score is presented in three systems, each consisting of three staves. The notation is in treble clef. The first system contains 12 measures of music. The second system contains 12 measures, with the final measure marked with a double bar line and a repeat sign. The third system contains 12 measures, also ending with a double bar line and a repeat sign. The music is a trumpet call for a retreat, characterized by its rhythmic and melodic structure.

16. TATTOO.

Quick.

The musical score for 'Tattoo' is presented in three systems, each with three staves. The music is written in common time (C) and begins with a 'Quick.' tempo marking. The first system consists of three staves of music. The second system also consists of three staves, with a repeat sign (double bar line with two dots) appearing at the beginning of each staff. The third system consists of three staves, with a repeat sign at the beginning of each staff. The music features a mix of eighth and sixteenth notes, with some rests and dynamic markings.

TATTOO—Continued.



TATTOO—*Concluded.*

The musical score is arranged in three systems, each consisting of three staves. The first system begins with two triplets of eighth notes on the top staff, followed by a dotted quarter note and an eighth note. The second system continues with eighth and quarter notes. The third system features a melodic line on the top staff and a bass line on the bottom staff, both concluding with a final cadence. The notation includes various note values, rests, and articulation marks such as slurs and accents.

TRUMPET CALLS, ETC.

17. TAPS.



18. MESS.

Quick.

Musical notation for '18. MESS.' in C major, 2/4 time. The piece is marked 'Quick.' and consists of three staves. The melody is characterized by eighth notes and triplets. The first staff begins with a quarter note G4, followed by eighth notes A4 and B4, and a quarter note C5. The second staff continues with eighth notes B4 and A4, and a quarter note G4. The piece concludes with a quarter note G4 and a quarter rest.

19. SICK.

Quick.

Musical notation for '19. SICK.' in C major, 2/4 time. The piece is marked 'Quick.' and consists of two staves. The melody is characterized by eighth notes and triplets. The first staff begins with a quarter note G4, followed by eighth notes A4 and B4, and a quarter note C5. The second staff continues with eighth notes B4 and A4, and a quarter note G4. The piece concludes with a quarter note G4 and a quarter rest.

20. CHURCH.

Slow.

Two staves of musical notation in 3/4 time. The first staff begins with a treble clef and a 3/4 time signature. The melody consists of quarter and eighth notes, with a dotted quarter note in the second measure. The second staff continues the melody with similar note values and rests.

21. RECALL.

Moderato.

Two staves of musical notation in 2/4 time. The first staff begins with a treble clef and a 2/4 time signature. The melody features eighth-note patterns and triplets, indicated by a '3' above a bracket. The second staff continues the piece, ending with a double bar line and repeat dots.

22. ISSUE.

Allegro.

Two staves of musical notation in 3/8 time. The first staff begins with a treble clef and a 3/8 time signature. The melody is more rhythmic, featuring eighth and sixteenth notes, with a triplet of eighth notes in the second measure. The second staff continues the melody, ending with a double bar line and repeat dots.

TRUMPET CALLS, ETC.

23. OFFICER'S CALL.

Quick.

Two staves of music in 6/8 time. The first staff begins with a treble clef and a key signature of one flat. The melody consists of eighth and quarter notes. The second staff continues the melody, ending with a quarter note and a dotted quarter note.

24. FIRST SERGEANT'S CALL.

Quick.

One staff of music in 2/4 time. The melody features eighth notes and triplets of eighth notes. There are three triplet markings with the number '3' above them.

25. FATIGUE.

Quick.

Three staves of music in 3/8 time. The melody includes eighth notes, quarter notes, and triplets of eighth notes. There are three triplet markings with the number '3' above them.

26. SCHOOL.

Quick.

Musical score for '26. SCHOOL.' in 2/4 time, marked 'Quick.' The score consists of two staves. The first staff begins with a treble clef and a 2/4 time signature. It contains a sequence of notes: a quarter note G4, an eighth note A4, a quarter note B4, a quarter note C5, a quarter note B4, a quarter note A4, a quarter note G4, a quarter note F4, a quarter note E4, a quarter note D4, a quarter note C4, and a quarter note B3. There are three asterisks (*) above the notes B4, C5, and B4. The second staff continues the melody with notes: a quarter note A4, a quarter note G4, a quarter note F4, a quarter note E4, a quarter note D4, a quarter note C4, a quarter note B3, a quarter note A3, a quarter note G3, a quarter note F3, a quarter note E3, and a quarter note D3.

27. THE GENERAL.

Quick.

Musical score for '27. THE GENERAL.' in 3/4 time, marked 'Quick.' The score consists of seven staves. The first staff begins with a treble clef and a 3/4 time signature. It contains a sequence of notes: a quarter note G4, an eighth note A4, an eighth note B4, a quarter note C5, a quarter note B4, a quarter note A4, a quarter note G4, a quarter note F4, a quarter note E4, a quarter note D4, a quarter note C4, and a quarter note B3. There are three asterisks (*) above the notes B4, C5, and B4. The second staff continues the melody with notes: a quarter note A4, a quarter note G4, a quarter note F4, a quarter note E4, a quarter note D4, a quarter note C4, a quarter note B3, a quarter note A3, a quarter note G3, a quarter note F3, a quarter note E3, and a quarter note D3. The third staff contains notes: a quarter note G4, an eighth note A4, an eighth note B4, a quarter note C5, a quarter note B4, a quarter note A4, a quarter note G4, a quarter note F4, a quarter note E4, a quarter note D4, a quarter note C4, and a quarter note B3. There are three asterisks (*) above the notes B4, C5, and B4. The fourth staff contains notes: a quarter note A4, a quarter note G4, a quarter note F4, a quarter note E4, a quarter note D4, a quarter note C4, a quarter note B3, a quarter note A3, a quarter note G3, a quarter note F3, a quarter note E3, and a quarter note D3. The fifth staff contains notes: a quarter note G4, an eighth note A4, an eighth note B4, a quarter note C5, a quarter note B4, a quarter note A4, a quarter note G4, a quarter note F4, a quarter note E4, a quarter note D4, a quarter note C4, and a quarter note B3. There are three asterisks (*) above the notes B4, C5, and B4. The sixth staff contains notes: a quarter note A4, a quarter note G4, a quarter note F4, a quarter note E4, a quarter note D4, a quarter note C4, a quarter note B3, a quarter note A3, a quarter note G3, a quarter note F3, a quarter note E3, and a quarter note D3. The seventh staff contains notes: a quarter note G4, an eighth note A4, an eighth note B4, a quarter note C5, a quarter note B4, a quarter note A4, a quarter note G4, a quarter note F4, a quarter note E4, a quarter note D4, a quarter note C4, and a quarter note B3. There are three asterisks (*) above the notes B4, C5, and B4.

TRUMPET CALLS, ETC.

DRILL SIGNALS.

28. ATTENTION.

Slow.

29. FORWARD.

Slow.

30. HALT.

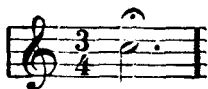

31. QUICK TIME.

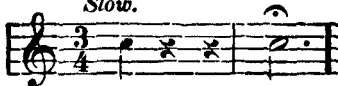
Slow.

32. DOUBLE TIME.

Slow.

33. CHARGE.

Quick.

Repeat at will.

The musical notation for '33. CHARGE.' consists of two staves in 3/8 time. The first staff begins with the tempo marking 'Quick.' and contains six measures of music. The second staff contains three measures of music, with the instruction 'Repeat at will.' written above the final measure. The notes are primarily eighth and sixteenth notes, often beamed together.

34. GUIDE RIGHT.

Slow

The musical notation for '34. GUIDE RIGHT.' is a single staff in 2/4 time. It begins with the tempo marking 'Slow'. The first measure contains a quarter note G4. The second measure contains a quarter note A4 with a fermata above it.

35. GUIDE LEFT.

Slow.

The musical notation for '35. GUIDE LEFT.' is a single staff in 2/4 time. It begins with the tempo marking 'Slow.'. The first measure contains a quarter note G4. The second measure contains a quarter note A4 with a fermata above it.

36. GUIDE CENTER.

Slow.

The musical notation for '36. GUIDE CENTER.' is a single staff in 2/4 time. It begins with the tempo marking 'Slow.'. The first measure contains a quarter note G4. The second measure contains a quarter note A4 with a fermata above it. The third measure contains a quarter note B4.

87. FOURS RIGHT, OR BY THE RIGHT FLANK.

Slow.

The musical notation for '87. FOURS RIGHT, OR BY THE RIGHT FLANK.' is a single staff in 2/4 time. It begins with the tempo marking 'Slow.'. The first measure contains a quarter note G4. The second measure contains a quarter note A4 with a fermata above it. The third measure contains a quarter rest. The fourth measure contains a quarter note B4 with a fermata above it.

TRUMPET CALLS, ETC.

38. FOURS LEFT, or BY THE LEFT FLANK.



39. COLUMN RIGHT.

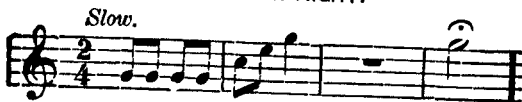

40. COLUMN LEFT.

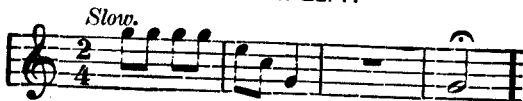

41. RIGHT OBLIQUE.

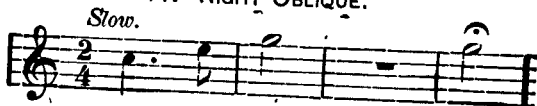

42. LEFT OBLIQUE.

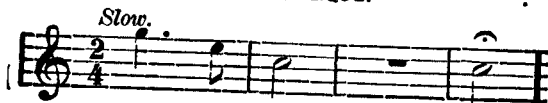

43. RIGHT FRONT INTO LINE.

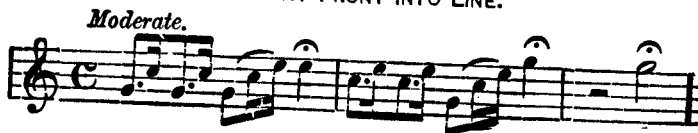

44. LEFT FRONT INTO LINE.



45. FACE TO THE REAR.



46. ON RIGHT INTO LINE.



47. ON LEFT INTO LINE.



48. COMPANY RIGHT TURN.



TRUMPET CALLS, ETC.

49. COMPANY LEFT TURN.



50. COMMENCE FIRING.

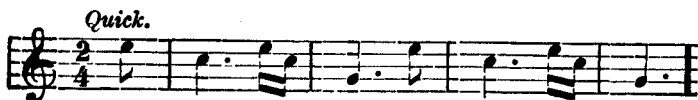

51. CEASE FIRING.



52. AS SKIRMISHERS.

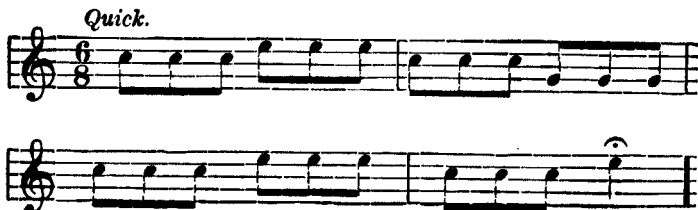

53. TO THE REAR.



54. RALLY.



55. LIE DOWN.



56. RISE.



MISCELLANEOUS TRUMPET CALLS.**57. PRESIDENT'S MARCH.***Quick time.*

Musical notation for '57. PRESIDENT'S MARCH' in C major, 2/4 time. The piece consists of five staves of music. The first staff begins with a treble clef and a common time signature. The melody is characterized by eighth and sixteenth notes, with some dotted rhythms. The second staff features a triplet of eighth notes. The third staff contains two more triplet markings. The fourth and fifth staves continue the melodic line with various rhythmic patterns and accents.

58. GENERAL'S MARCH.*Quick time.*

Musical notation for '58. GENERAL'S MARCH' in C major, 2/4 time. The piece is shown on a single staff. It begins with a treble clef and a common time signature. The melody is composed of eighth and sixteenth notes, with a triplet of eighth notes at the end of the piece.

GENERAL'S MARCH—*Concluded.*

59. FLOURISHES FOR REVIEW.

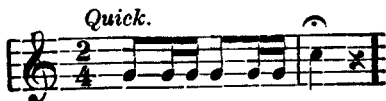

60. TO THE COLOR.



TRUMPET CALLS, ETC.

TO THE COLOR—*Concluded.*

Two staves of musical notation in treble clef, 2/4 time. The first staff contains four measures of music. The second staff contains four measures of music, with the letters "D. C." written above the final measure.

Quick time.

61. ROGUE'S MARCH.

Three staves of musical notation in treble clef, 2/4 time. The first two staves each contain three measures of music. The third staff contains three measures of music, with the final measure marked with an 'x'.

Repeat at will.

62. FUNERAL MARCH.

Very slow.

Three staves of musical notation in treble clef, 2/4 time. Each staff begins with a dynamic marking of 'f' (forte). The first two staves each contain four measures of music. The third staff contains four measures of music.

QUICKSTEPS.

63. QUICKSTEP NO. 1.

Quick.

The musical score for "63. QUICKSTEP NO. 1" is written in 2/4 time and marked "Quick." It consists of six staves of music. The first staff begins with a treble clef and a 2/4 time signature. The music is a single melodic line. The third staff ends with the word "End." and a double bar line. The sixth staff also ends with "End." and a double bar line. The piece features a variety of rhythmic patterns, including eighth and sixteenth notes, and rests.

QUICKSTEP NO. 1—*Concluded.**End.*

64. QUICKSTEP NO. 2.



65. QUICKSTEP NO. 3.



QUICKSTEP NO. 3—*Concluded.*

66. QUICKSTEP NO. 4.

F TRUMPET:



C CROOK:

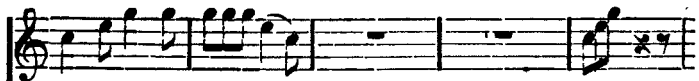

QUICKSTEP No. 4—*Concluded.**Second time. End.*

Musical notation for the second time of Quickstep No. 4, ending. It consists of two staves. The first staff contains a melodic line with a repeat sign at the beginning and a double bar line with repeat dots at the end. The second staff contains a bass line with rests and a final melodic phrase.

Da Capo.

Musical notation for the first time of Quickstep No. 4, da capo. It consists of two staves. The first staff contains a melodic line with a repeat sign at the beginning and a double bar line with repeat dots at the end. The second staff contains a bass line with rests and a final melodic phrase.

67. QUICKSTEP No. 5.

F TRUMPET:

Musical notation for the F Trumpet part of Quickstep No. 5. It is a single staff in 6/8 time, starting with a treble clef and an F-clef. The melody consists of eighth and sixteenth notes.

C CROOK:

Musical notation for the C Crook part of Quickstep No. 5. It is a single staff in 6/8 time, starting with a treble clef and a C-clef. The melody consists of eighth and sixteenth notes.

End.

Musical notation for the end of Quickstep No. 5. It consists of two staves. The first staff contains a melodic line with a double bar line and repeat dots at the end. The second staff contains a bass line with rests and a final melodic phrase.

QUICKSTEP No. 5—*Concluded.*

Da Capo.

3. TO THE COLOR.

FIFE. 80 =

DRUM. *f* *t t t t t* *f t t f*

f *f r* *f f f f*

9

4. THE LONG ROLL, or TO ARMS.

r r r r

5. REVEILLE.

FIFE. 140 =

DRUM. *t r r r r r t r*

7 7 8 7 7 8

REVEILLE—Continued.



60 = *Slow Scotch.*



REVEILLE—*Continue'*120 = ♩ *Austrian.*

♩ *Austrian.*
 d d d d d d d d

&c.
 r t

140 = ♩ *Hessian.*

DOUBLE DRAG. &c.
 d d d d d d d d

DRUM. r t

TATTOO—Concluded.

The TATTOO signal is shown in two staves. The top staff contains five measures of music, each with a wavy line above the notes. The bottom staff contains three measures of music, each with the letter 'r' above it.

After the three
Rolls repeat
Doubling
to the end.

9. RECALL.

80 =

The RECALL signal is shown in two staves. The top staff is in 3/8 time and has four measures with notes and rests. The bottom staff is in 4/4 time and has four measures with notes and rests.

10. FIRST CALL.

90 =

The FIRST CALL signal is shown in three staves. The top staff is in 4/4 time and has three measures. The middle and bottom staves also have three measures each, with notes and rests.

DRUM AND FIFE SIGNALS.

11. FIRST SERGEANT'S CALL.

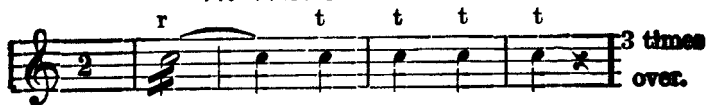

12. CEASE FIRING.



APPENDIX.

The following are the sections of the "Army Regulations, 1889," referred to in the text of the Drill Regulations.

ARTICLE III.

RANK AND PRECEDENCE OF OFFICERS [EXTRACT].

11. The relative rank between officers of the Navy and Army is as follows, lineal rank only being considered :

Admiral with General (when office exists).

Vice-Admiral with Lieutenant-General (when office exists).

Rear Admiral with Major-General.

Commodore with Brigadier-General.

Captain with Colonel.

Commander with Lieutenant-Colonel.

Lieutenant-Commander with Major.

Lieutenant with Captain.

Lieutenant (junior grade), with First Lieutenant. Ensign with Second Lieutenant.

ARTICLE XLVII.

HONORS, SALUTES, OFFICIAL VISITS, CEREMONIES.

422. The following officers will be received with standards and colors dropping, officers and troops saluting, and the bands and field music playing as below :

The President—The band playing "The President's March." The General—The band playing "The General's March." The Lieutenant-General or Major-General commanding—Trumpets sounding three flourishes or drums beating three ruffles. A Major-General—Two flourishes and two ruffles. A Brigadier-General—One flourish or one ruffle.

423. The Vice-President, the members of the Cabinet, the Chief Justice, the President of the Senate, the Speaker of the House of Representatives, and Governors within their respective States and Territories, receive the same honors as are paid to a General Commanding-in-Chief.

424. American or foreign envoys or ministers are received with the honors due to a Lieutenant-General.

425. Officers of the Navy are received with the honors due their assimilated rank.

426. Officers of Marines, and of the Volunteers and Militia, when in the service of the United States, receive the honors due to like grades in the regular service.

427. Officers of a foreign service are received with the honors due to their rank.

428. The national or regimental colors passing guard or other armed body, will be saluted, the trumpets sounding, and the drums beating a march.

Officers or enlisted men passing the colors will give the prescribed salute whether with or without arms.

429. No honors are paid by troops when on the march or in trenches and no salute is rendered when marching in double time, or at the trot or gallop.

430. The commanding officer is saluted by all commissioned officers in command of troops or detachments. If troops are armed, arms will be brought to a "carry" before the salute is tendered.

431. All officers salute each other on meeting, and in making or receiving official reports. When under arms the salute is made with the sword or saber, if drawn; otherwise with the hand.

A mounted officer dismounts before addressing a superior not mounted. In all cases the junior salutes first.

432. On official occasions, officers when indoors and under arms do not uncover, but salute with the sword, if drawn; otherwise with the hand. If not under arms, they uncover and stand at attention, but do not salute.

433. When an enlisted man without arms passes an officer he salutes him, using the hand farthest from the officer. If mounted he salutes with the right hand.

434. An enlisted man armed with the saber, when out of ranks, salutes all officers with the saber, if drawn; if not he salutes with the hand. If on foot, and armed with a rifle or carbine, he salutes as prescribed for a sergeant. A mounted soldier dismounts before addressing an officer not mounted.

435. A non-commissioned officer, or private in command of a detachment without arms, salutes all officers with the hand. If the detachment be on foot, and armed with the rifle or carbine, he brings his piece to carry, and salutes as prescribed for a sergeant. If armed with a saber, he salutes with the saber.

436. An enlisted man being seated, rise, on the approach of an officer, faces towards him and salutes. If standing he faces the officer for the same purpose. If the parties remain in the same place, or on the same ground, such compliments need not be repeated. Soldiers actually at work do not cease it to salute an officer unless addressed by him.

437. An enlisted man makes the prescribed salute with the weapon he is armed with ; or, if unarmed, with the hand, before addressing an officer. He also makes the same salute after receiving a reply.

438. Indoors, a non-commissioned officers or soldier, when unarmed, uncovers and stands at attention upon the approach of an officer, but does not salute; in all other cases he salutes as heretofore prescribed, without uncovering.

439. When an officer enters the room where there are soldiers, the word "Attention" is given by some one who perceives him, when all rise and remain standing in the position of a soldier until the officer leaves the room. Soldiers at meals do not rise. Officers in citizens' dress are saluted in the same manner as when in uniform.

440. Soldiers at all times and in all situations, pay the same compliments to officers of the Army, Navy and Marines, and to officers of the Volunteers and Militia in the service of the United States, as to officers of their own particular regiments and corps.

441. Officers will at all times, acknowledge the courtesies of enlisted men by returning salutes given, saluting as prescribed in the drill regulations. When several officers in company are saluted, all who are entitled to salute return it.

ARTICLE XLVII.

FUNERAL HONORS [EXTRACT].

474. The funeral escort of the Secretary of War or General-in-Chief shall consist of a regiment of infantry, a battalion of cavalry, and two batteries of artillery ; of the lieutenant-general or the major-general commanding, a regiment of infantry, a battalion of cavalry, and a battery of artillery ; of a major-general, a regiment of infantry, two companies of cavalry, and a battery of artillery ; of a brigadier-general, a regiment of infantry, a company of cavalry, and a platoon of artillery ; of a colonel, a regiment ; lieutenant-colonel, six companies ; a major, four companies ; a captain, one company ; a subaltern, half a company.

475. The funeral escort of an officer will be commanded by an officer of the same grade as the deceased; if none such be present, by one of the next inferior grade. The form of escorting a corpse to the grave is prescribed in the drill regulations of the several arms of service.

476. The funeral escort of a non-commissioned staff officer shall consist of sixteen rank and file, commanded by a sergeant; of a sergeant, of fourteen rank and file, commanded by a sergeant; of a corporal, of twelve rank and file, commanded by a corporal; and of a private, of eight rank and file, commanded by a corporal.

ARTICLE XLVIII.

COMPLIMENTS FROM GUARDS AND SENTINELS.

516. During the day, the guard of a camp or garrison turns out and presents arms to a general officer, the commander of the post or camp, and the officer of the day.

517. Guards will turn out and present arms to officers entitled to the compliment as often as they pass. The personal guards of general officers will turn out to the general whose guards they are, and to his superiors in rank.

518. All guards will turn out under arms when armed parties approach their posts; to parties commanded by commissioned officers they will present arms, officers saluting.

519. The National or regimental colors passing a guard will be saluted, the trumpets or field music sounding a march.

520. When an officer entitled to a salute passes guards in the act of relieving, both will salute at the word of command from the senior officer. If he passes in rear of a guard it does not salute, but stands at a "carry."

521. The sentinel at the post of the guard, on the approach of a body of troops or officer entitled to the compliment, will cry, "Turn out the guard," and announce who approaches.

522. Guards do not turn out as a matter of compliment after sunset, nor will any compliments be paid by them between retreat and reveille.

523. Between reveille and retreat, sentinels will salute all officers by presenting arms.

524. Mounted sentinels, armed with the saber and with sabers drawn, will salute all officers by presenting saber; if armed with the carbine only, they will, on the approach of an officer, take the position of advance carbine. In challenging, and

holding communications, they will take the position of advance carbine, raise pistol, or guard, accordingly as they are armed with the carbine, pistol or saber

525. A sentinel in a sentry box, upon the approach of an officer, will stand at a carry, and, if armed with the rifle or carbine will present arms as the officer passes.

526. Between retreat and reveille, except when challenging, a sentinel (not in a sentry box) will, when an officer approaches, face outward, and stand at a carry until the officer has passed.

527. All guards and sentinels will pay the same compliments to civil officers of the Government; to officers in the military or civil service of foreign powers; to officers of the Navy and Marine Corps, and to officers of volunteers and militia when in the service of the United States, that are directed to be paid to officers of the army of corresponding rank.

INFANTRY DRILL REGULATIONS.

Circular, }
No. 16. }

WAR DEPARTMENT,
Adjutant General's Office,
Washington, July 28, 1897.

The following adaptation of the manual for the service magazine rifle, caliber .30 to the Springfield rifle, caliber .45, is approved and published for use when required.

By order of the Secretary of War:

SAM'L BRECK,
Acting Adjutant General.

FOR SPRINGFIELD RIFLE, CALIBER .45.

INDIVIDUAL INSTRUCTION WITH ARMS.

1. The recruit should, as soon as possible, be taught the use of his rifle, its care and preservation.

When fair progress has been made in the individual instruction without arms, the recruit will be taught the manual of arms; instruction without arms and that with arms alternating.

Part of each drill with arms should be devoted to marching.

2. The manual of arms is explained for double rank, but for the instruction of recruits it is first executed in single rank, omitting reference to the rear rank.

At the command *fall in*, the recruits, usually not exceeding four, assemble (Par. 20, D. R.), pieces at order arms.

The piece shall not be carried loaded except when specially ordered.

3. To prevent accidents, the chamber will be opened (Par.12) whenever the squad is first formed, and again, just before being dismissed. *This rule is general.*

4. The cadence of the motions is that of quick time; the recruits will at first be required to give their whole attention to the details of the motions, the cadence being gradually acquired as they become accustomed to handling their arms.

Before requiring recruits to take a position or execute a motion for the first time, the instructor will execute the same for illustration; after which he will cause them to execute it by themselves, then to execute it together at command.

The movements relative to the cartridge, fixing and unfixing bayonet, adjusting sight, breaking and forming stack, are executed with promptness and regularity, but not in cadence.

5. Being at a halt, the movements are, for the purpose of

instruction, divided into motions and executed in detail; in this case the command of execution determines the prompt execution of the first motion, and the commands, TWO, THREE, etc., that of the other motions.

To execute the movements in detail, the instructor first cautions: *By the numbers*; all movements divided into motions are then executed as above explained until he cautions: Without *the numbers*; or commands movements other than those in the manual of arms.

MANUAL OF ARMS.

General Rules.

1. *First.* In all positions of the left hand at the balance (center of gravity, bayonet unfixed), the thumb clasps the piece except in *present* arms and *load*, in which two positions the thumb is extended along the stock; the sling is included in the grasp of the hand.

Second. In all positions of the piece "diagonally across the body," the positions of the piece, left arm, and hand, are the same as in *port* arms.

Third. In resuming the *order* from any position in the manual, the motion next to the last concludes with the butt of the piece about three inches from the ground, the left hand above and near the right, steadying the piece, fingers extended and joined, forearm and wrist straight and inclined downward.

Fourth. The piece is habitually carried with the hammer at the safety notch.

2. The recruit being in the position of the soldier, the instructor will first cause him to place his piece in the following position:

Position of Order Arms.

The butt rests evenly on the ground, barrel to the rear, the toe of the butt on a line with, and touching, the toe of the right shoe, arms hanging naturally, elbows near the body, right hand holding the piece between the thumb and fingers, the first two fingers in front, the others in rear.

3. Being at order arms: 1. *Present*, 2. ARMS.

Carry the piece in front of the center of the body with the right hand, barrel to the rear and vertical, grasp it with the left hand at the balance, forearm horizontal and resting against the body. (Two) Grasp the small of the stock with the right hand.

1. *Order*, 2. ARMS.

Let go with the right hand and regrab the piece just above the lower band, back of the hand to the right; let go with the left hand, carry the piece with the right to the right side, barrel to the rear, hand near the thigh, butt about three inches from the ground, left hand steadying the piece above the right, fingers extended and joined, forearm and wrist straight and inclined downward. (TWO) Lower the piece gently to the ground with the right hand, drop the left quickly by the side, and take the position of order arms.

4. Being at order arms: 1. *Port*, 2. ARMS.

Raise and throw the piece diagonally across the body; lock plate to the front, grasp it smartly with both hands, the right, palm down, at the small of the stock; the left, palm up, at the balance, thumb clasping the piece, barrel sloping to the left and crossing opposite the junction of the neck with the left shoulder; right forearm horizontal; left forearm resting against the body; piece near the body.

In the instruction of the recruit, to prevent interference with or apprehension by the man on his left, especially when bayonets are fixed, care should be taken in coming to the position of port arms, and like positions of the piece, that the muzzle be not swung to the rear nor dropped farther to the left than necessary for taking the position.

Being at port arms: 1. *Order*, 2. ARMS.

Let go with the right hand, lower and carry the piece to the right with the left hand, regrab it with the right just above the lower band, back of hand to the front, let go with the left hand, lower and turn the piece with the right, bringing the barrel to the rear, butt about three inches from the ground, and hand near the thigh; steady the piece in this position with the left hand above the right, fingers extended and joined, forearm and wrist straight and inclined downward. (TWO) Lower the piece gently to the ground with the right hand, drop the left by the side, and take the position of order arms.

5. Being at present arms: 1. *Port*, 2. ARMS.

Carry the piece diagonally across the body and take the position of port arms.

Being at port arms: 1. *Present*, 2. ARMS.

Carry the piece to a vertical position in front of the center of the body, barrel to the rear, and take the position of present arms.

6. Being at order arms: 1. *Right shoulder*, 2. ARMS.

Raise and carry the piece diagonally across the body with the right hand, lock plate to the front, grasp it at the balance with the left hand, palm up, thumb clasping the piece; carry the right hand quickly to the butt, embracing it, heel between

the first two fingers, the thumb and fingers closed on the stock, the barrel sloping to the left and crossing opposite the junction of the neck with the left shoulder; left forearm resting against the body, the piece, left arm, and hand, being in the same position as at port arms. (TWO) Raise, and place the piece on the right shoulder, barrel up, trigger guard in the hollow of the shoulder, the right elbow against (or near) the side, the right hand retaining its grasp of the butt, the hand directly in front of the elbow; at the same time slip the left hand, fingers extended and joined, down to the breech block. (THREE) Drop the left hand by the side.

Care should be taken in the instruction of recruits that in the position of right shoulder arms the right hand is kept directly in front of the elbow, which insures steadiness of the piece on the shoulder, sufficient elevation of the muzzle to prevent interference with the men in the rear rank, and uniformity of appearance in the position of the piece.

Being at right shoulder arms: 1. *Order*, 2. ARMS.

Press the butt down quickly with the right hand and throw the piece diagonally across the body, grasp it with the left hand at the balance, the position of the left arm, hand, and piece, being the same as in port arms, the right hand retaining its grasp of the butt. (TWO) Let go with the right hand, lower and carry the piece to the right with the left hand, at the same time regrab the piece with the right just above the lower band, back of hand to the front, let go with the left hand, lower and turn the piece with the right, bringing the barrel to the rear, butt about three inches from the ground, and hand near the thigh; steady the piece in this position with the left hand above the right, fingers extended and joined, forearm and wrist straight and inclined downward. (THREE) Lower the piece gently to the ground with the right hand, drop the left by the side, and take the position of order arms.

7. Being at port arms: 1. *Right shoulder*, 2. ARMS.

Change the right hand to the butt, heel between the first and second fingers, thumb and fingers closed on the stock, and place the piece on the right shoulder, barrel up, trigger guard in the hollow of the shoulder, the right elbow against (or near) the side, the right hand directly in front of elbow; at the same time slip the left hand, fingers extended and joined, down to the breech block. (TWO) Drop the left hand by the side.

Being at right shoulder arms: 1. *Port*, 2. ARMS.

Press the butt down quickly with the right hand and throw the piece diagonally across the body, lock plate to the front, grasp it with the left hand at the balance, as in port arms, the right hand retaining its grasp at the butt. (TWO) Change the

right hand to the small of the stock, and take the position of port arms.

8. Being at right shoulder arms: 1. *Present*, 2. ARMS.

Press the butt down quickly with the right hand and throw the piece diagonally across the body, lock plate to the front, grasp it with the left hand at the balance, as in port arms, the right hand retaining its grasp of the butt. (TWO) Change the right hand to the small of the stock and take the position of port arms. (THREE) Carry the piece to a vertical position in front of the center of the body, barrel to the rear, and take the position of present arms.

Being at present arms: 1. *Right shoulder*, 2. ARMS.

Take the position of port arms. (TWO) Change the right hand to the butt, heel between the first and second fingers, thumb and fingers closed on the stock, and place the piece on the right shoulder, barrel up, trigger guard in hollow of the shoulder, the right elbow against (or near) the side, the hand directly in front of elbow, at the same time slip the left hand, fingers extended and joined, down to the breech block. (THREE) Drop the left hand by the side.

Rifle Salute.

9. Being at right shoulder arms: Carry the left hand smartly to the small of the stock, forearm horizontal, palm of the hand down, thumb and fingers extended and joined, forefinger against the piece. (TWO) Drop the left hand by the side.

The first motion of the salute is made six yards before passing the officer, holding the hand at the small of the stock until the salute is acknowledged or the officer passed.

Indoors the salute is made from the position of order arms; carry the left hand smartly to the right side, forearm horizontal, or nearly so, palm of the hand down, thumb and fingers extended and joined, forefinger against piece. (TWO) Drop the left hand to the side.

The rifle salute is prescribed for individual soldiers with arms, except sentinels, who salute by presenting arms.

The Rests.

10. *Fall out*, *Rest*, and *At ease* are executed as without arms.

On resuming the attention take the position of order arms.

11. Being at order arms: 1. *Parade*, 2. REST.

Carry the right foot six inches straight to the rear, left knee slightly bent, carry the muzzle in front of the centre of the

body, barrel to the left, grasp the piece with the left hand just below the stacking swivel, and with the right hand below and against the left.

1. *Squad*, 2. ATTENTION.

Resume the order, the left hand quitting the piece opposite the right breast.

12. To dismiss the squad.

The instructor commands: 1. *Port*, 2. ARMS, 3. DISMISSED.

When the instruction has progressed to include loading, to insure that no cartridge is left in the chamber, the instructor commands: 1. *Port*, 2. ARMS, 3. OPEN CHAMBER, 4. CLOSE CHAMBER, 5. DISMISSED.

After closing the chamber the hammer is brought to the safety notch.

13. Being at order arms: 1. *Fix*, 2. BAYONET.

Execute parade rest; grasp the shank of the bayonet with the right hand; draw the bayonet from the scabbard and fix it on the barrel, glancing at the muzzle; resume the order.

14. Being at order arms: 1. *Unfix*, 2. BAYONET.

Take the position of parade rest, grasp the shank of the bayonet firmly with the right hand, wrest it from the barrel, and glancing at the scabbard, return it, the blade passing between the left arm and body; regrasp the piece with the right hand and resume the order.

15. If marching, the bayonet is fixed or unfix in the most expeditious and convenient manner, and the piece returned to the position in which it was when the order to fix or unfix bayonet was given.

16. Being at order arms, bayonet fixed: 1. *Charge*, 2. BAYONET.

Half face to the right, carrying the right heel six inches to the rear and three inches to the right of the left heel, at the same time raise the piece with the right hand, inclining the barrel to the front, grasp it with the left at the balance, back of hand down, thumb clasping piece, elbow against the body, grasp the small of the stock with the right hand and bring the point of the bayonet to the height of the chin, right hand supporting the stock firmly against the front of right hip, the body inclining slightly forward.

1. *Order*, 2. ARMS.

Face to the front, at the same time let go the piece with the right hand and lower it to the right side with left hand, regrasp it with the right just above the lower hand, back of hand to the right, and lower the piece, bringing the butt about three inches from the ground and hand near the thigh; steady the piece in this position, with the left hand above the right, fingers extended and joined, forearm and wrist straight and

inclined downward. (TWO) Lower the piece gently to the ground with the right hand, drop the left by the side, and take the position of order arms.

17. Being at port arms, bayonet fixed: 1. *Charge*, 2. BAYONET. Half face to the right, carrying the right heel six inches to the rear and three inches to the right of the left heel, and at the same time bring the piece to the position of charge bayonet.

To resume port arms: 1. *Port*, 2. ARMS.

Face to the front, and at the same time take the position of port arms.

18. Being at right shoulder arms: 1. *Charge*, 2. BAYONET.

Press the butt down quickly with the right hand and throw the piece diagonally across the body, lock plate to the front, grasp it with the left hand, as in port arms, the right hand retaining its grasp of the butt. (TWO) Change the right hand to the small of the stock. (THREE) Half face to the right, carrying the right heel six inches to the rear and three inches to the right of the left heel, and at the same time bring the piece down to the right side and take the position of charge bayonet.

Being at charge bayonet: 1. *Right shoulder*, 2. ARMS.

Face to the front and at the same time take the position of port arms. (TWO) Change the right hand to the butt, heel between the first and second fingers, thumb and fingers closed on the stock, and place the piece on the right shoulder, barrel up, trigger guard in the hollow of the shoulder, the right elbow against (or near) the side, the hand directly in front of the elbow, at the same time slip the left hand, fingers extended and joined, down to the breech block. (THREE) Drop the left hand to the side.

Positions Kneeling and Lying Down.

19. The movements of kneeling, lying down, and rising, are first taught without arms; they are executed as with arms, except that in the position kneeling the right hand rests on the right thigh, and in moving to and from the lying position the right hand is placed on the ground; in the position lying down the forearms are against each other on the ground, left arm in front.

At the command *kneel*, *lie down*, or *rise*, the hammer will be brought to the safety notch, if not already there. *This rule is general.*

20. Being at order arms: KNEEL.

Each front rank man half faces to the right, carrying the right foot so that the toe shall be about ten inches to the rear and ten inches to the left of the left heel; kneel on right knee.

bending the left, left toe slightly inclined to the right, right leg pointing directly to the right; weight of body resting on right heel; place left forearm across left thigh, hand hanging naturally; the piece remains in the position of order arms, right hand grasping it above the balance. *This is the position of order kneeling.*

Each rear rank man steps off obliquely to the right with the left foot, planting the toe opposite the middle of the interval to his right and in line with the left heel of his front rank man; at the same time placing the butt of his piece against his left foot, the toe of butt in line with toe of foot; he then kneels as prescribed for the front rank.

21. Being at the order kneeling: RISE.

Rise and take the position of order arms; the rear rank men covering their file leaders.

22. Being at the order kneeling: LIE DOWN.

Each front rank man places the right knee against the left heel. (TWO) Draw back the left foot and place the knee on the ground; place the left hand well forward on the ground and lie flat on the belly, thus inclining the body about thirty-five degrees to the right; the piece is lowered at the same time with the right hand, toe resting on the ground, barrel up, muzzle off the ground, left hand at the balance, left elbow on the ground, right hand at the small of the stock, opposite the neck. *This is the position lying down.*

The rear rank men move back thirty-six inches in the most convenient manner without rising, and lie down as prescribed for the front rank.

23. Being in the position lying down: RISE.

Place the left hand on the ground and raise the body on the knees; draw up and place the left foot by the side of the right knee, raise and place the piece in the position of the order kneeling. (TWO) Raise and take the position of order arms; the rear rank men close to facing distance on their file leaders.

24. Being at the order standing: LIE DOWN.

Each front rank man takes the position of order kneeling, except that the right knee is placed against the left heel. (TWO) Draw back the left foot and place the knee on the ground; place the left hand well forward on the ground and lie flat on the belly, thus inclining the body about thirty-five degrees to the right; the piece is lowered at the same time with the right hand, toe resting on the ground, barrel up, muzzle off the ground, left hand at the balance, left elbow on the ground, right hand at the small of the stock opposite the neck.

The rear rank men step back thirty-six inches and lie down as prescribed for the front rank.

25. Being in the position lying down: **KNEEL.**

Place the left hand on the ground and raise the body on the knees; draw up and place the left foot by the side of the right knee, raise and place the piece in the position of the order kneeling; the rear rank men take the position of the order kneeling and then move forward thirty-six inches in the most convenient manner without rising.

To Load.

26. The recruits are at first taught to load and fire without using cartridges; after a few lessons they should use dummy cartridges, and when well instructed, the drill may close with a few rounds of blank cartridges.

27. No cartridges will be used, except when indicated by the words *with dummy (blank or ball) cartridges*, preceding the command **LOAD**. *This rule is general.*

*28. Being in line, standing at the order: 1. *Squad*, 2. **Load**.

Each rear-rank man steps off obliquely to the right with the left foot, planting the toe opposite the middle of the interval to his right and in line with the left heel of his front-rank man; the front-rank men half face to the right; both ranks then carry the right heel six inches to the rear and three inches to the right of the left heel, turning the toes of both feet slightly inward, at the same time raise the piece with the right hand, drop it into the left at the balance, muzzle at the height of the chin, left elbow against the body, small of the stock at the waist; place the right thumb on the head of the hammer, forefinger on the trigger, the other fingers against the small of the stock and half cock the piece, lower the muzzle, barrel sloping downward at an angle of about twenty-five degrees, at the same time open chamber; look toward the chamber, remove the cartridge shell if necessary; take a cartridge between the thumb and first two fingers, place it in the bore, pressing it home with the thumb; close chamber with the right thumb, cast the eyes to the front, carry the right hand to the small of the stock and raise the muzzle to the height of the chin. *The last position is the position of load.*

If kneeling the position of the piece is similar—the left forearm rests on the left thigh, the left hand grasping the piece at the balance and the muzzle is at the height of the chin.

If lying down the left hand steadies the piece at the balance, the toe of the butt resting on the ground, the muzzle off the ground.

When lying down in double rank the rear rank men do not load.

The piece being in the position of load, that is with the

*The lines in small type show the changes made by Circular No. 24, Headquarters of the Army, A. G. O., Nov. 15, 1897.

hammer at the half cock, is brought to the ready by the command: 1. *Squad*, 2. **READY**.

At the second command cock the piece with the right thumb and return the hand to the small of the stock.

29. Being in any position, pieces loaded: 1. *Draw*, 2. **CART-RIDGE**.

Take the position of load, if not already there, open the chamber gently to avoid complete ejection of the cartridge from the chamber, take and return cartridge to box or belt, close chamber, bring hammer to safety notch, and carry the right hand to the small of the stock.

30. Pieces loaded, and being in the position of load or at the ready, to order arms: 1. *Order*, 2. **ARMS**.

At the command **ARMS**, bring the hammer to the safety notch, take the position of order arms, the front rank men similarly as from charge bayonet; the rear rank men raise the muzzle of their pieces (to clear the front rank men), step back and cover their file leaders, at the same time bringing the piece to the position of order arms.

If kneeling, both ranks *take the order kneeling*.

If sights are raised (par. 37) they should be laid down at the first command.

Cartridge boxes, if used, are closed after executing the order, order kneeling, position lying down, or cease firing (par. 59).

31. Being at the ready: **AIM**.

Raise the piece with both hands and support the butt firmly against the hollow of the right shoulder, right thumb extended across the stock inclined forward and diagonally to the left, barrel horizontal; slip the left hand back to the guard, little finger resting against the bottom of the thumb piece of the cam latch, left elbow resting against the body, and as far to the right as it can be placed with ease, right elbow as high as the shoulder; incline the head slightly forward and a little to the right, cheek against the stock, left eye closed, right eye looking through the notch of the rear sight so as to perceive the top of the front sight; second joint of forefinger resting lightly against the front of the trigger, but not pressing it.

Each rear rank man aims through the interval at the right of his file leader, and inclines slightly forward, to advance the muzzle of his piece beyond the front rank. When lying down in double rank, the rear rank men do not aim nor fire.

32. In aiming kneeling, the left elbow rests on the left knee, point of elbow in front of kneecap.

In aiming lying down, raise the piece with both hands and slip it through the left to the trigger guard; rest on both elbows and press the butt firmly against the right shoulder.

33. FIRE.

Press the finger against the trigger; fire without deranging the aim, and without lowering or turning the piece.

34. LOAD.

Lower the piece to the position of load, and load.

35. The exercise is continued by the command: 1. *Squad*, 2. **READY**, 3. **AIM**, 4. **FIRE**, 5. **LOAD**.

If the instructor does not wish the pieces to be reloaded after firing, in place of the command **LOAD** he commands 1. *Order*, 2. **ARMS**.

At the command *Order*, bring the piece to the position of load, eject the empty shell by opening the chamber, close the chamber, bring the hammer to the safety notch, lower the sight leaf, if raised, and carry the right hand to the small of the stock; at the command **ARMS** take the position of order arms, the front rank men similarly as from charge bayonet; the rear rank men raise the muzzle of their pieces (to clear the front rank men), step back and cover their file leaders, at the same time bringing the piece to the position of order arms.

If kneeling both ranks take the order kneeling.

36. To accustom the recruits in the position of aim, to await the command **FIRE**: 1. *Recover*, 2. **ARMS**.

At the command *Recover*, withdraw the finger from the trigger; at the command **ARMS**, take the position of load, the piece being retained at the ready.

In recovering arms when kneeling or lying down, the piece is brought to the position for loading kneeling, or lying down, respectively.

37. When the recruits are thoroughly instructed in the adjustments of the sight and the principles of aiming as laid down in the "Firing Regulations for Small Arms," they will be required to aim using the graduations of the rear sight corresponding to the distances indicated. For this purpose the instructor commands: 1. *At* (so many) *yards*, 2. *Squad*, 3. **READY**, 4. **AIM**.

At the first command, both ranks take the position of load and adjust the sight with the right hand.

The instructor assures himself by careful inspection that each man sets his sight at the range indicated; when satisfied that the subject is fully comprehended, he will exercise the men in aiming at a designated object. For this purpose he commands: 1. *At that tree* (or *At.....*), 2. *At* (so many) *yards*, 3. *Squad*, 4. **READY**, 5. **AIM**.

At the first command, both ranks take the position of load and fix the eyes on the object indicated; at the second command adjust the sight and immediately fix the eyes upon the object again.

38. The distance announced in the command should be, as nearly as possible, the true distance of the object indicated.

The men should be practised in aiming at objects above and below them.

39. Being at order arms: 1. *Open*, 2. *BOXES*.

Steady the piece by grasping it with the left hand just below the stacking swivel, forearm against the body; open the box with the right hand and resume the order.

In a similar manner each man, as his box is inspected, closes it and resumes the order.

40. Being at order arms: 1. *Inspection*, 2. *ARMS*.

At the command *ARMS*, bayonets are fixed and cartridge boxes opened.

Each man, as the inspector approaches him, executes *port arms, open chamber*.

The inspector takes the piece with the right hand, grasping it just below the lower band, back of hand down (the man dropping the hands by the side), inspects it, and hands it back in the position in which received. The man receives it with the left hand at the balance, closes chamber, brings the hammer to the safety notch, resumes *port arms*, comes to *order arms*, and unfixes bayonet.

As the inspector returns the piece the next man executes *inspection arms*, and so on through the squad. Should the pieces be inspected without handling, the man closes chamber, brings the hammer to the safety notch, grasps the piece with the right hand at the small of the stock, comes to *order arms*, and unfixes bayonet, when the inspector passes to the next man who immediately executes *inspection arms*.

41. The inspection of the arms begins on the right, after which the inspector may pass in rear and inspect boxes from left to right.

Boxes are closed as soon as inspected.

Stack Arms.

42. Three pieces only are used in making a stack; pieces not so used are, in this connection, termed loose pieces.

Preparatory to stacking arms, the squad must have counted fours and must be in line at the order.

43. 1. *Stack*, 2. *ARMS*.

At the command *Stack*, each even number of the front rank raises his piece with the right hand, grasp it with the left at the upper band, and rests the butt between his feet, barrel to the front, muzzle inclining slightly to the front and opposite the center of the interval on his right, the thumb and forefinger

raising the stacking swivel; each even number of the rear rank then passes his piece, barrel to the rear, to his file leader, who grasps it between the bands with his right hand and throws the butt about twenty-eight inches in advance of his own and opposite the middle of the interval, the right hand slipping to the upper band, the thumb and forefinger raising the stacking swivel, which he engages with that of his own piece; each odd number of the front rank raises his piece with the right hand, carries it well forward, barrel to the front, the left hand guiding the stacking swivel, engages the lower hook of the swivel of his own piece with the free hook of that of the even number of the rear rank; he then turns the barrel outward into the angle formed by the other two pieces and holds the butt about four inches above the ground and six inches in front of the line of the toes.

At the command ARMS, each odd number of the front rank lowers the butt of his piece to the ground.

The stacks being formed, the piece of the odd numbers in the rear rank are passed to the even numbers in the front rank, who lay them on the stacks. The pieces of the guides and the file closers are laid on the stacks at the same time.

Each man, on finishing handling pieces, takes the position of the soldier.

The instructor may then rest or dismiss the squad, leaving the arms stacked.

On assembling, the men take their places in rear of the stacks.

44. 1. *Take*, 2. ARMS.

At the command *Take*, the loose pieces are returned by the even numbers; each even number of the front rank then grasps his own piece with the left hand, the piece of his rear rank man with his right hand, grasping both between the bands; each odd number of the front rank grasps his piece in the same way with the right hand.

At the command ARMS, each odd number of the front rank disengages his own piece by raising the butt from the ground and then turning the piece to the right, detaching the piece from the stack; each even number of the front rank disengages and detaches his piece by turning it to the left, and then passes the piece of his rear rank man to him, and all resume the order.

Unless care is taken by the odd number to hold and place the butt of his piece in front of the line of the toes, there is danger that the front sight will be caught and bent by the ramrod of the piece of the even number on turning the piece to make or break the stack.

Should any four have numbers two and three blank files,

number one rear rank will take the place of number two rear rank in making and breaking the stack; the stacks made or broken, he resumes his post.

45. Being in single rank, arms are stacked and taken on the same principles as in the double rank; at the preparatory command number three steps back and covers number two; numbers two and three execute what has been explained for the even numbers of the front and rear rank, respectively; number three then resumes his place; number one uses his piece as explained for the odd number of the front rank. The piece of number four is passed as explained for the odd numbers of the rear rank.

Like precaution as in double rank should be used in making and breaking stack to avoid injury to the sights.

46. The following positions of the piece are intended mainly for use in extended order and route marches. Whenever the commands for any of these are given, the piece will be shifted in the most convenient manner, but for desirable uniformity in the method of carrying the piece from the right shoulder to the left shoulder and return when in close order, the method therefor is prescribed in paragraph 48.

47. 1. *Trail*, 2. **ARMS**.

The piece is grasped with the right hand just above the balance, right arm slightly bent, barrel up, muzzle inclined slightly to the front.

When it can be done without danger or inconvenience to others, as on the firing line, the piece may be grasped at the balance and the muzzle lowered until the piece is horizontal; a similar position in the left hand may be used in like case.

The piece should be brought to the position of trail arms on coming in doors.

48. Being at right shoulder arms:

1. *Left shoulder*, 2. **ARMS**. Press the butt down quickly with the right hand and bring the piece to nearly a vertical position without lowering it, grasp it with the left hand at the small of the stock and carry and place the piece on the left shoulder, barrel up, trigger guard in the hollow of the shoulder; replace the right hand at the butt with the left hand, heel between the first and second fingers, thumb and fingers closed on the stock, elbow near the body, hand directly in front of the elbow, and drop the right hand by the side.

1. *Right shoulder*, 2. **ARMS**. Press the butt down quickly with the left hand and bring the piece to nearly a vertical position without lowering it, grasp it with the right hand at the small of the stock, and carry and place the piece on the right shoulder, barrel up, trigger guard in the hollow of the shoulder;

replace the left hand at the butt with the right hand, and take the position of right shoulder arms.

49. 1. *Sling*, 2. ARMS.

The right arm is passed between the rifle and the sling which rests upon the shoulder, piece in rear of shoulder, muzzle down and barrel to the rear; right hand steadying the piece.

On route marches the piece may be slung on either shoulder. The gun sling should never be so tightly drawn that it cannot be readily adjusted.

50. 1. *Secure*, 2. ARMS.

The piece is held in the right hand at the balance, barrel down, sloping downward and to the front; right hand supported against the front of the right hip, upper arm against the stock. A corresponding position in the left hand may be used.

51. When the recruits are first exercised in marching with arms, the instructor orders the pieces in position before putting the squad in march, and before passing from quick to double time; he also causes the recruits to be at quick time at the *right shoulder* before ordering the *halt*.

52. When the marchings and the manual of arms are thoroughly understood, the following general rules govern:

(1) If at the order, bring the piece to the right shoulder at the first preparatory command for marching.

(2) A disengaged hand in double time is held as when without arms.

(3) If at the right shoulder, left shoulder, trail, or port arms, bring the piece to the order on halting; the execution of the order to begin immediately after halting.

(4) When the facings, side step, back step, alignments, open and close ranks, taking intervals, distances, and assembling from bayonet exercise, are executed from the order, raise the piece to the trail while in motion and resume the order on halting.

When this applies to other movements it is therein stated.

53. In the battle exercises, or whenever circumstances require, the regular positions of the manual of arms and the firings may be ordered without regard to the previous position of the piece; such movements as are not in the manual will be executed without regard to motions or cadence.

FIRINGS.

54. The post of the instructor is three paces in rear of the squad, but in actual firing he places himself where he can best make himself heard and at the same time observe the effect of the fire; the objective should be in plain view and so designated as to be easily distinguished by all.

After exercises in firing, before dismissing the squad or passing to other instruction, inspection will be made to insure that no cartridge is left in chamber.

55. The commands for firing are the same whether the squad be standing, kneeling, or lying down. The commands for kneeling or lying down precede the commands for firing.

56. At the first preparatory command for firing, the squad being in line standing, both ranks take the position of load as prescribed in paragraph 28, and the cartridge box, if worn, is slipped to the hip and opened; at the command indicating the distance, the sights are adjusted; the cartridge box is closed and replaced after executing cease firing (par. 59).

Volley Firing.

57. The squad being in line fronting the object to be fired upon, pieces loaded: 1. *Fire by squad*, 2. *At* (such an object). 3. *At* (so many) yards, 4. *Squad*, 5. READY, 6. AIM, 7. FIRE, 8. LOAD.

To fire another volley at the same object, but with a new line of sight. 1. *At* (so many) yards, 2. *Squad*, 3. READY, 4. AIM, 5. FIRE, 6. LOAD.

To fire another volley at a new object: *At* (such an object). 2. *At* (so many) yards, 3. *Squad*, 4. READY, 5. AIM, 6. FIRE, 7. LOAD.

58. The object and range will be indicated in the preparatory commands for all kinds of fire, as illustrated in the preceding examples.

If the object be at a considerable angle to the front of the squad, the instructor will change the front of the squad so as to face the object.

The commands are given at sufficient intervals to allow them to be executed as prescribed. The command *fire* is given when the pieces appear to be steady.

These rules are general.

To Cease Firing.

59. CEASE FIRING.

Take the position of load, if not already there, draw the cartridge, or eject the empty shell by opening the chamber, close the chamber, bring the hammer to the safety notch, lower the sight leaf, if raised, and take the order, order kneeling, or the position lying down, as the case may be. If standing, the rear rank men then step back and cover their file leaders, taking the order as prescribed in paragraph 30.

60. The command (or signal) *cease firing* is always used to stop the firing of whatever kind, and may be given at any time after the first preparatory command for firing, whether the firing has actually commenced or not.

This rule is general.

To Fire at Will.

61. 1. *Fire at Will*, 2. *At* (such an object), 3. *At* (so many) yards, 4. *Squad*, 5. **READY**, 6. **COMMENCE FIRING**.

At the command *commence firing*, each man independently of the others takes careful aim at the object, fires, loads and continues the fire as rapidly as is consistent with taking careful aim at each shot. The men should be taught to load rapidly and to aim deliberately.

62. 1. **CEASE FIRING**, 2. **LOAD**.

The firing will stop; at the second command pieces not already there will be brought to the position of load, and those not loaded will be loaded.

This is intended to interrupt the firing, for the purpose of steadying the men, to change to another method of firing, or to retain the pieces loaded for the time being, in which latter case the instructor should direct the hammers to be brought to the safety notch.

Rapid Fire.

63. This fire is employed under usual conditions for ranges within which the trajectory is comparatively flat, and the firing should be very effective. 1. *Rapid fire*, 2. *At* (such an object), 3. *At* (so many) yards, 4. *Squad*, 5. **READY**, 6. **COMMENCE FIRING**.

At the command indicating the distance, if 600 yards or less, the sights will be laid; the firing is executed as the firing at will, but with as great rapidity as will admit of effective aiming at the object.

If firing at will, to begin rapid fire: 1. *Rapid fire*, 2. **COMMENCE FIRING**, when rapid fire is taken up.

Instruction in the *rapid fire* should not be given until after the *fire at will* is well executed.

To fire further volleys the commands would be as prescribed in paragraph 57.

64. Rules for the application of the different fires will be found in the battle exercises.

HISTORY OF THE DRILL REGULATIONS.

The American troops were drilled by the English Tactics during the early part of the war of the Revolution. In 1779 Congress adopted Baron de Steuben's abridgement of the Prussian Tactics. These were used by the United States Army until the commencement of the war of 1812 and by the Militia until 1820. In 1812 a very imperfect abridgement of the French Tactics of 1791, by General Alexander Smyth, was published under the sanction of the War Department (*Régiment Concernant l'Exercice et les Manœuvres de l'Infanterie; du 1er Août., 1791*). In 1813 Lieut. Colonel William Duane of the Rifles, an ex-editor, produced a handbook of instruction for the squad and company, which was used to some extent in the army. In this year Congress requested the President to have prepared for its approval "a military system of discipline for the Infantry of the Army and Militia of the United States." This resolution was not acted upon owing to the occupation of the officers with field service, and during the war of 1812 tactical instruction was in a state of chaos, every officer in this matter being a law unto himself. De Lacroix had published in Boston a bad translation by Macdonald of the French tactics, and with this and a copy of the original French, General Scott at the camp in Buffalo in 1814 personally instructed two brigades of Brown's division: This was the first introduction here of the French system entire. With some modifications, it was adopted by the War Department and is known as "the system of 1815." Its use by the militia was made compulsory in 1820. The "system of 1825" was adapted from the French by a board consisting of Scott, Brady, Fenwick, Thayer and Worth. It was originally taken by the French from the Prussian system of Frederick the Great and was used throughout the Revolutionary and Napoleonic wars of France. Under authority of Congress, General Scott in 1834 prepared the adaptation of the Prussian system known by his name. The improvement in firearms finally compelled a change from the formal movements of Scott, and Hardee's translation of the French system for their *Chasseurs à pied* was adopted as far as the school of the Battalion. From its peculiar double quick step, it was familiarly known as the "Shanghai Drill." Casey's Revision of Hardee's system was authorized during the Civil War and continued in use until superseded August 1, 1867, by Upton's Tactics, which now in their turn give place to these "Drill Regulations."

Editor Army and Navy Journal.

Questions as to the interpretation of these Drill Regulations will be answered in the "Army and Navy Journal."

INDEX

TO

INFANTRY DRILL REGULATIONS.

Details under each subject are arranged alphabetically.
An Index to Intervals and Distances, and to all General Rules and Rules of General Application is added.

ORDER OF SUBJECTS.

	Pars.		Pars.
CLOSE ORDER	10-484	Extended order—Cont'd.	
School of the soldier ...	10-178	The platoon	559-576
School of the company.	179-248	The company	577-601
School of the battalion.	249-367	The battalion	602-620
Evolutions of the regi- ment	368-459	The regiment	621
The brigade	460-478	The brigade in battle...	622-631
The division	479-483	The division in battle...	632-635
The corps	484	Ceremonies	663-768
EXTENDED ORDER	502-635	Trumpet calls, etc	769
General principles	502-510	Miscellaneous subjects, pages 3-7 and	1-9, 485-501, 636-662
Leading the squad	511-517		
The squad	518-558		

CLOSE ORDER.

SCHOOL OF THE SOLDIER.

Adjustments of sight	91, 92	Blows with butt	172-174
Alignments	112, 121-126	By the numbers	48
Aim	85, 88, 90-92	By the right or left flank, march	131, 132
At ease	22, 59	Cadence of motions	47
Attention	21	Cadence of steps	31, 34
Attention, to resume	23, 60	Carry, from charge bayo- net	67
Back step	39, 40, 112	Carry, from fix bayonet..	62
Backward, march	129	Carry, from guard	158
Battle exercises, manual and firings	113	Carry, from order	51
Bayonet exercise	151-178		

SCHOOL OF THE SOLDIER—Continued.

	Pars.		Para.
Carry, from port.....	57	General rules—Continued.	
Carry, from present.....	53	guide in oblique march-	
Carry, from right shoulder	55	ing.....	136
Carry, from unfixed bayonet.	63	hammer at safety	
Carry, position of.....	50	notch.....	49, 70
Cartridges, when used.....	93, 94	manual of arms.....	49
Cease firing.....	147-149	manual of arms in bat-	
Change direction.....	133	tle exercises.....	113
Change step.....	41	manual of arms, march-	
Charge bayonet, from carry	67	ing and halting.....	112
Charge bayonet, from or-		manual of arms, when	
der.....	68	marchings, etc., are	
Close boxes.....	79, 96, 97	understood.....	112
Close chamber.....	83	open chambers.....	46
Close ranks, at order.....	112	Guard.....	157
Column of files.....	117, 131, 215	Guide in oblique marching,	
Combination of parries,		general rules.....	136
points, etc.....	175-178	Halt.....	33, 112
Commence firing.....	150	Hammer at safety notch... 49, 70	
Covering and marching on		Individual instruction with	
points.....	42, 43	arms.....	44-113
Dismiss the squad.....	25, 61	Individual instruction with-	
Distance between ranks... 98, 118		out arms.....	18-43
Distance between ranks		Inspection of cartridge box-	
before lying down.....	73	es and arms.....	96, 97
Distance in column of files.	131	Instructors.....	13, 14, 111, 115
Distances and intervals,		Intervals and distances,	
bayonet exercise.....	152-156	bayonet exercise.....	152-156
Double time, from halt or		Intervals in ranks.....	19, 122
quick time. 5, 34, 35, 112, 138, 139		Knapsacks, to unsling and	
Draw cartridge.....	84	sling.....	98
Eyes right or left.....	26	Kneel and lie down.....	69-76
Facings.....	27, 28, 112	Kneel, from lying down... 76	
Fall in.....	19, 20, 45, 120	Kneel, from order.....	71
Fall out.....	22, 59	Left shoulder.....	108
Fire.....	86, 88	Length of steps.....	31, 34, 37-39
Firings.....	142-150	Lie down, from order kneel-	
Fix bayonet, from carry... 62		ing, and order.....	73, 75
Fix bayonet, from order... 63		Load and fire, with and	
Fix bayonet, marching... 66		without cartridges.....	93, 94
Fix bayonet, with rod bayo-		Load, from carry or order. 77, 112	
net.....	65	Load, from fire.....	87, 88
Forming the squad.....	120	Load, kneeling or lying	
Forward, march.....	127	down.....	78
General rules:		Manual of arms.....	49-113
cease firing.....	148	Manual of arms, marching	
firings.....	146	and halting.....	112

SCHOOL OF THE SOLDIER—Continued.

	Pars.		Pars.
Marching with arms, recruits.....	111	Right shoulder, from carry or order.....	54
Marchings.....	127-141	Right shoulder, from port..	58
Mark time.....	36, 40, 135	Right shoulder, when taken	112
Oblique march.....	134-137	Rise, from order kneeling..	72
Open boxes.....	96	Rise, from position lying down.....	74
Open chamber.....	46, 83	Route marches, positions of piece.....	106
Open ranks at order.....	112	Salute with hand.....	29, 485
Order, from carry.....	52	Salute with rifle.....	95, 485
Order, from charge bayonet.....	68	Secure.....	110
Order, from guard.....	158	Setting-up exercises.....	80
Order, from load or ready..	82	Short step.....	37, 40, 135
Order, from port.....	57	Side step.....	38, 40, 112
Order, from right shoulder.....	56	Sizing and forming the squad.....	119, 120
Order, from unfix bayonet.....	63	Sling arms.....	109
Order, kneeling.....	71	Squad leader.....	115
Order, on halting.....	112	Stack arms.....	99-105
Order, position of.....	50	Step, when lost.....	128
Parade rest.....	24, 60	Steps.....	81-41
Parries.....	165-169	Steps, bayonet exercise...157-164,	171
Points.....	170, 171	Take arms.....	102, 104
Port, from right shoulder..	58	The squad.....	114-150
Port, from carry or order..	57	Thrusts.....	170, 171
Position of the soldier.....	21	To the rear, march.....	130
Positions of piece for extended order and route marches.....	106	Trail.....	107, 112
Present, from carry.....	53	Turnings.....	140, 141
Quick time.....	31-33, 139	Unfix bayonet, from carry..	68
Ready.....	80, 81	Unfix bayonet, from order..	68
Recover (from aim).....	89	Unfix bayonet, from port..	64
Rest.....	22, 59	Unfix bayonet, marching..	66
Rests.....	22-24, 59, 60	Unfix bayonet with rod bayonet.....	65
Rifle salute.....	95, 485	Volley firing.....	145, 146

SCHOOL OF THE COMPANY.

Alignments.....	189	Captain, in firings, general rule.....	193
At ease, marching.....	246	Captain, in turn and halt.....	192
Attention, to resume..192, 245, 246		Captain, guides, etc., in all wheels by fours, general rule.....	197
Captain in column of fours, twos, etc., general rule...197			
Captain in column of platoons.....	223		

SCHOOL OF THE COMPANY—Continued.

	Pars.		Pars.
Change of direction in column of fours	200-202	Column of twos or files, movements of.....	216, 217
Change of direction, slight.	195	Commands of chiefs of platoons, general rule.....	220
Change of flanks and center of company.....	247	Company movements executed as in squad.....	192
Change of guides to line of file closers and reverse...	247	Count fours	186
Close ranks	191	Detachments, details, etc....	192
Column of files from column of fours or twos.....	215	Dismiss the company	194
Column of fours or twos, from column of twos or files	218, 219	Distance leading four, subdivision, etc., advances before halting, general rule.....	209
Column of fours, to the front, from column of platoons.....	242	Dress, in column of fours, general rule.....	199
Column of fours, to the front, from line	203	Enlisted men in line of file closers, general rule.....	193
Column of fours, to the right or left, from line...196, 198		Face and march to the rear, from line.....	211, 212
Column of fours, to the right or left, from line of platoons in columns of fours.....	241	Fall in.....19, 20, 120, 187, 188	
Column of fours, twos, or files, faced to the flank or rear	217	File closers, column of fours, twos, etc., general rule.....	197
Column of platoons, change direction.....	227-229	File closers, duties and responsibility of...page 4...	248
Column of platoons, face and march to the rear...	230	File closers, in loadings and firings	193
Column of platoons, halts, obliques, marches.....	224	File closers, to change flank	204
Column of platoons, to the front, from columns of fours.....	243	First sergeant, position of..	247
Column of platoons, to the front, from line	235	Forming the company...187, 188	
Column of platoons, to the right or left, from line ..221, 226		Forward march taken upon completion of wheel by fours.....	199
Column of platoons, to the right or left, from line of platoons in columns of fours.....	237	Fours right or left...196, 207, 237	
Column of twos or files, from column of fours or twos.....	214, 215	Fours right or left about, in column of fours	206
		General rules :	
		announcement of guide in changing direction.....	228
		captain, in alignments..	189
		captain in column of fours, twos, etc.....	197
		captain in firings.....193, 266	
		captain in turn and halt.....	192

SCHOOL OF THE COMPANY—Continued.

	Pars.		Pars.
General rules—Continued.		Line, from column of platoons.....	231-234, 235
captains, guides, etc., in all wheels by fours.	197	Line of platoons in columns of fours, on right or left, from column of fours....	240
chief of subdivision in column, alignments..	189	Line of platoons in columns of fours, to the front, from column of fours.....	239
chief of subdivision in column takes post, when.....	220	Line of platoons in columns of fours, to the front, from line.....	238
commands by chiefs of platoons.....	220	Line of platoons in columns of fours, to the right or left, from column of fours.....	244
distance leading four, subdivision, etc., moves to front before halting.....	209	Line of platoons in columns of fours, to the right or left, from column of platoons.....	237
dress in column of fours.....	190	Line, on right or left, from column of fours.....	208
enlisted men in line of file closers.....	193	Line, on right or left, from column of platoons.....	234
file closers, column of fours, twos, etc.....	197	Line, to the front, from column of fours.....	210
guide of second or rear platoon in column....	226	Line, to the front, from column of platoons.....	236
guides, in column of fours, twos, etc.....	197	Line, to the front, from line of platoons in columns of fours.....	238
guides, manual of arms for.....	193	Line, to the right or left, from column of fours....	207
guides take post, when.	189	Line, to the right or left, from column of platoons.....	231-233
march taken up on completion of wheel by fours.....	199	Manual of arms, guides, etc., general rule.....	193
non-commissioned officer commanding detachment, etc., position of rifle.....	193	March at ease.....	246
pivot, fixed in wheels by fours.....	197	March by the flank, from column of platoons.....	237
Guide, forming line from column of platoons.....	231	March by the flank, from line.....	196
Guide, in turn and halt.....	192	March taken upon completion of wheel by fours, general rule.....	199
Guides of platoons.....	222	March to the rear, from line.....	211, 212
Guides take post at command "front".....	189		
Instruction of officers, etc..	185		
Leading four or subdivision, when halted.....	209		
Line, from column of fours.....	207, 210		

SCHOOL OF THE COMPANY—Continued.

	Pars.		Pars.
March to the rear in column of fours.....	206	Pivot, fixed and movable.....	196, 197, 200
Movements executed as in squad.....	192	Platoons.....	179-183, 192
Non-commissioned officer commanding detachment, etc., position of rifle, general rule.....	193	Platoons, movements by.....	220-244
Oblique, in column of fours.....	205	Posts of officers, etc.....	184
Obstacles.....	213	Right or left forward, fours right or left.....	203
Officers marching at ease or route step, position of sword.....	246	Route step, and at ease.....	245, 246
Open ranks.....	190	Sections.....	179-183
		Sizing the company.....	186
		Squad leader.....	180, 183
		Squads.....	179-183
		Subdivisions of company.....	179-183
		Swing of arms.....	192
		To the rear, from line.....	211, 212

SCHOOL OF THE BATTALION.

Adjutant and sergeant-major post guides for close column.....	337	Close column, deployments of.....	346, 347
Adjutant, etc., when guide is changed, general rule.....	300	Close column, designated company in front.....	337
Alignments.....	279, 280	Close column, faced to the front, from column of fours.....	339
Arrangement of companies, table.....	253	Close column, faced to the rear, from column of fours.....	346
Arrangement of fractions of different regiments.....	253	Close column, faced to the right or left, from column of fours.....	341
Attention, resuming.....	269	Close column, from column of companies.....	335
Band and field music, post of.....	256	Close column, from line....	338
Band takes its position in line, when.....	260	Close column, in oblique direction.....	339
Captains required to drill battalion.....	252	Close column, movements of.....	343, 345
Change direction by the flank in close column....	344	Close ranks.....	264
Change front.....	315-318	Color and guard.....	254, 265, 498, 499
Change of direction in column of companies.....	305, 308, 309	Column of companies face and march to the rear...	307
Change of direction in line, slight.....	273	Column of companies from close column.....	336
Changing file closers to opposite flank.....	285	Column of companies from right or left to march to left or right.....	304
Close column.....	334-347		
Close column, change direction by the flank.....	344		

SCHOOL OF THE BATTALION—Continued.

	Pars.		Pars.
Column of companies, from street column.....	367	Column of platoons, from line of platoon columns.....	361
Column of companies, halt.....	306	Column of platoons, take and close distances.....	351
Column of companies, successively, from column of fours.....	302	Command of major after firings, general rule.....	266
Column of companies, to the front, from column of fours.....	330	Commands repeated or given by captains.....	250
Column of companies, to the front, from column of platoons.....	350	Deployments of close column.....	346, 347
Column of companies, to the rear, from line.....	301	Designations of companies and wings.....	253
Column of companies, to the right or left, from line.....	298, 299	Dismiss the battalion.....	270
Column of companies, to the right or left, from line of columns of fours.....	327	Distance between companies in column of fours.....	282
Column of companies, to the right or left, from line of platoon columns.....	359	Distance in close column, general rule.....	334
Column of fours, from close column.....	342	Distance in column of subdivisions.....	296
Column of fours, from column of companies.....	330	Equalizing companies and the battalion.....	253, 262
Column of fours, from column of platoons.....	348	Face and march to the rear in line.....	276, 277
Column of fours, movement same as in company.....	286	Field and staff, posts of....	255
Column of fours, successively, from column of companies.....	303	File closers in close column, general rule.....	334
Column of platoons, from column of companies....	349	File closers, to change....	265
Column of platoons, from column of fours.....	348	Fire at will.....	268
Column of platoons, from line.....	348	Fire by battalion.....	268
		Fire by company.....	267
		Formation, advancing considerable distances.....	275
		Formation of battalion....	253
		Forming the battalion....	257-261
		Fractions of different regiments, positions of.....	253
		Full distance, from close column.....	336
		General rules:	
		adjutant, etc., when guide is changed.....	300
		captain at command guide center.....	272
		captain dressing company.....	258

SCHOOL OF THE BATTALION—Continued.

	Pars.		Pars.
General rules—Continued.		Line of companies in columns of fours, from column of companies	326
captain in loadings and firings.....	193, 266	Line of companies in columns of fours, from line of platoon columns marching by the flank ...	365
command of major after firings.....	266	Line of companies in columns of fours, gain ground toward flank and front	322
distance in close column.....	334	Line of companies in columns of fours, on right or left, from column of fours	326
file closers in close column.....	334	Line of companies in columns of fours, to the front, from column of fours	325
guides of subdivisions in column.....	300	Line of companies in columns of fours, to the front, from line.....	320
successive formations..	288	Line of companies in columns of fours, to the right or left, from column of fours.....	320
Guide, announcement of...	251	Line of platoon columns, close and extend intervals	355
Guides, cover	311	Line of platoon columns, formations. 356, 360, 362, 363, 366	366
Guides marching at route step and at ease.....	319	Line of platoon columns, intervals	354
Habitual formation advancing considerable distances.....	275	Line of platoon columns, march by the flank	364
In mass.....	334-347	Line of platoon columns, movements same as in line of columns of fours..	357
Instruction of officers.....	252	Line of platoon columns, on right or left, from column of platoons.....	362
Intervals in line.....	257	Line of platoon columns, to the front, from line....	356
Intervals in line of columns of fours.....	325, 332, 333	Line of platoon columns, to the front, from column of fours	366
Intervals in line of platoon columns.....	354	Line of platoon columns, to the front, from column of platoons.....	365
Line by two movements from column of fours ..	296-297		
Line, from close column..	346, 347		
Line from column of companies.....	310, 312-314		
Line from line of companies in columns of fours .	324		
Line from line of platoon columns.....	358		
Line of columns of fours, movements like battalion in line	321		
Line of companies in columns of fours at close intervals	325		
Line of companies in columns of fours, change direction	323		
Line of companies in columns of fours, close and extend intervals.....	332, 333		

SCHOOL OF THE BATTALION—Continued.

	Pars.		Pars.
Line of platoon columns, to the right or left, from column of companies....	360	March in line.....	271
Line of platoon columns, to the right or left, from column of platoons.....	361	March, and face to the rear.....	276, 277
Line, on right or left, from column of companies.....	312	Mounted officers.....	255
Line, on right or left, from column of fours.....	289	Movements by platoons.....	331, 348-366
Line, on right or left, from column of platoons.....	352	Movements in close column.....	343-345
Line, to or on right or left, from close column.....	336	Movements in line of columns of fours.....	321
Line, to the front, from column of companies.....	313, 314	Non-commissioned officer commanding company, post of.....	259
Line, to the front, from column of fours.....	290, 291	Oblique by heads of columns.....	322
Line, to the front, from column of platoons.....	353	Oblique change of front....	318
Line, to the front, from line of columns of fours....	324	Oblique in line.....	278
Line, to the front, from line of platoon columns.....	358	Obstacles.....	281
Line, to the right or left, from column of companies.....	310	Open ranks.....	263
Line, to the right or left, from column of fours....	287	Platoon column, defined...	354
Line, to the right or left, from column of platoons....	348	Ployments in close column.....	337-342
Loadings and firings.....	265, 266	Post of band and field music	256
Losing step.....	274	Post of non-commissioned officer commanding company.....	259
Manual of arms.....	265	Posts of field and staff....	255, 319
March at ease, and route step.....	319	Rests.....	269
March by the flank.....	282, 283	Route marches.....	319
		Simultaneous movements by companies, etc.....	251
		Square from street column	367
		Stack and take arms.....	269
		Staff and non-commissioned staff take post, when....	260
		Street column, formation and movements of.....	367

EVOLUTIONS OF THE REGIMENT.

Advance in line, line of columns or line of masses....	376	Change front, line of masses.....	442
Alignments.....	380, 440	Color and color guard....	254, 265, 496, 499
Band, posts of.....	369	Column at full distance....	401
Battalions awaiting completion of movement...	370	Column at full distance, change direction.....	402
Change front, line.....	453		

EVOLUTIONS OF THE REGIMENT—Continued.

	Pars.		Pars.
Column at full distance, face to the rear.....	403	Column of masses from column at full distance.....	411
Column at full distance, from column of masses..	412	Column of masses from line, etc., duties of adjutant.....	448
Column at full distance, movements same as in battalion.....	401	Column of masses, from line, rule for ployment...	410
Column of battalions, from line of column of fours.....	425-429	Column of masses in oblique direction, from column of fours.....	415
Column of battalions, on flank and interior battalion from line.....	426, 427	Column of masses, movements same as at full distance.....	417
Column of companies or platoons from line.....	401	Column of masses on flank and interior battalion from line.....	413, 414
Column of fours, from line of masses.....	446	Column of masses, principles for forming.....	410
Column of fours from right or left to march to left or right.....	382	Column of masses to the right or left, from line of masses.....	447
Column of fours from two lines.....	387	Column of platoons from line.....	401
Column of fours, movements explained from march.....	384	Commands, general rules...	370
Column of fours, movements same as in battalion.....	383	Deployments of column of masses.....	419-423
Column of masses, change direction by the flank...	418	Designation of battalions...	371
Column of masses, distances.....	410	Dismiss the regiment.....	375
Column of masses faced to the front, from column of fours.....	415	Distance, column of battalions.....	385
Column of masses faced to the front, from line of masses.....	448	Distance, column of fours, between battalions.....	382
Column of masses faced to the rear, from column of fours.....	416	Distance, column of masses	410
Column of masses faced to the rear, from line of masses.....	449	Distance, in two or more lines.....	385
Column of masses faced to the right or left, from column of fours.....	417	Distances, column of subdivisions.....	298
		Distances, in echelon.....	457
		Echelon.....	457-459
		Echelon, movements same as in line.....	458
		Face to the rear, line.....	377
		Firings.....	373
		Forming the regiment.....	371
		General rules for commands.....	370

EVOLUTIONS OF THE REGIMENT—Continued.

	Pars.		Pars.
Halt.....	379	Line of masses, change front.....	442
Intervals in line.....	371	Line of masses, extend and close intervals.....	433
Intervals, line of companies or platoons in columns of fours.....	409	Line of masses faced to the right or left, from column of fours.....	436
Intervals, line of masses....	371	Line of masses, from line of masses marching by the flank.....	445
Intervals, line of platoon columns.....	454	Line of masses, major.....	432
In two lines, on right or left, from column at full distance.....	405	Line of masses, march by the flank.....	443
In two lines, on right or left, from column of fours....	389	Line of masses marching by the flank, change direction.....	444
In two lines, position and movements of second line.....	385	Line of masses, movements same as in line.....	441
In two lines to the front, from column at full distance.....	407	Line of masses on flank and interior battalion, from line.....	434, 435
In two lines to the front, from column of fours... 394,	398	Line of masses, on right or left, from column of fours.....	437
In two lines to the right or left, from column of fours.....	386	Line of masses, on right or left, from column of masses.....	451
In two or three lines, from column of masses..... 422,	423	Line of masses, posting guides.....	432
Line by two movements, from column at full distance.....	408	Line of masses, to the front from column of fours... 438,	439
Line by two movements, from column of fours... 395,	396	Line of masses, to the front from column of masses.....	452
Line, from echelon of battalions.....	459	Line of masses to the right or left, from column of masses.....	450
Line, from line of columns.....	376	Line of platoons in columns of fours from line.....	400
Line of battalions in columns of fours, from column of masses.....	424	Line, on right or left, from column at full distance...	404
Line of companies in columns of fours from column of fours.....	399	Line, on right or left, from column of fours.....	388
Line of companies in columns of fours from line..	409	Line to the front, from column at full distance.....	406
Line of masses..... 432-452	452	Line to the front, from column of battalions..... 430,	431
Line of masses, adjutant and sergeant-major.....	432		
Line of masses, alignment .	440		

EVOLUTIONS OF THE REGIMENT—Continued.

Pars.	Page
Line to the front, from column of fours.....	390-393, 397
Line, to the right and left, from column of masses.....	419-421
Line, to the right or left, from column of fours....	383
March to the rear, line....	378
March by the flank, from line.....	381
Movements by battalions, simultaneous and separate.....	370
Movements by platoons....	454-456
Movements in echelon....	458, 459
Movements in line of columns of fours.....	399
Movements of column of masses.....	417
Movements of masses....	441-453
Open and close ranks.....	372
Orderlies and trumpeters, mounted.....	369
Ployments into column of masses.....	410-417
Posts of field, staff, and band.....	369
Regiment, composition....	368
Rests.....	374
Route marches.....	369
Route step and at ease....	400
Successive formations....	385
Trumpeters and orderlies mounted.....	369

THE BRIGADE.

Change of front.....	478	Line of masses, marchings.	474
Composition of the brigade.	460	Line of platoon columns, marchings.....	474
Distances between lines....	465	Line, on right or left, from column of fours.....	469
Designated formation for each regiment.....	470	Lines of columns of fours..	470
Designations of regiments..	461	Lines of masses.....	470
Drill exercises.....	464	Lines of platoon columns..	470
Habitual formation moving into position.....	464	Line to the front, from column of fours.....	468
Halt.....	472	Line to the right or left, from column of fours....	467
Interval between regiments.....	462	March by the flank.....	475
In two or more lines, from column of fours.....	468	March in line.....	471
Line, from column of fours.....	467-469	March to the rear, line....	473
Line, from column of platoons.....	470	Movements of regiments and battalions.....	464
Line, from line of columns of fours.....	476, 477	Orders of brigade commander.....	465
Line, from line of masses.476, 477		Posts of brigade commanders, staff, etc.....	466
Line, from line of platoon columns.....	476, 477	Posts of regiments.....	467
Line, march to the rear....	473	Re-form line from line of columns of fours, line of masses, or line of platoon columns.....	476, 477
Line of columns of fours, marchings.....	474		

THE DIVISION.

	Pars.		Pars.
Composition.....	479	Orders of division com-	
Designations of brigades...	481	mander.....	483
Distances between lines....	483	Post of division command-	
Evolutions.....	479	er.....	480
Interval between brigades..	482	Posts of brigades.....	481
Number of lines and forma-			
tion of each.....	482		
THE CORPS.....			484

EXTENDED ORDER.

GENERAL PRINCIPLES.

Alignments.....	509	Face to the front on halting	508
Attention fixed, signal.....	506	Instruction, when com-	
Basis.....	502	menced.....	503
Chief, leaving post.....	510	Maintenance of squad.....	502
Commencement of instruc-		March and stand at ease...	509
tion.....	503	Movement commenced, sig-	
Dressing, without com-		nal.....	506
mand.....	509	Movements always made	
Duties of officers and ser-		with reference to an en-	
geants.....	502	emy.....	504
Enemy, imaginary, out-		Position of piece.....	106, 113
lined or represented, defi-		Post of chief.....	510
nition.....	505	Signals, application.....	506
Extended order from any		Squad, when broken up....	502
formation.....	507	Stand and march at ease...	509

LEADING THE SQUAD.

Corporal, posts of... 510, 513, 517		Execution of movements,	
Execution of movements		manner.....	512
at signal).....	511	Exercises of squad.....	514
		Guide.....	515, 516

THE SQUAD.

Advance, from rally.....	531	Departures from general-	
Assembly.....	532	rules of fire discipline....	535
As skirmishers, forward....	523	Deploy as skirmishers, for-	
Base file or skirmisher... 515, 516,		ward and by the flank... 523,	524
520		Deploy from rally.....	531
Battle exercises.....	558	Deployment as skirmishers,	
Change direction or front..	530	general rule.....	531
Corporal, posts of... 510, 513, 517,		Deployments forward and	
520, 527, 528		by the flank, general rule	518

THE SQUAD—Continued.

	Pars.		Pars.
Execution of movements at signals.....	533	Intensity of fire, how regulated.....	544
Fire as skirmishers with counted cartridges.....	538, 545	Interval between skirmishers, general rule.....	519
Fire at will, and with counted cartridges.....	538, 544	Intervals, increase and diminish.....	525
Fire discipline.....	534-540	Kneel or lie down, general rule.....	522
Firings.....	541-546	Line of skirmishers, from line.....	523, 524
General rules:		Marchings.....	526-530
base file, skirmisher or guide.....	515, 516, 520, 521	Number of cartridges to be fired.....	545
deployment as skirmishers.....	521	Rally.....	531
deployment forward and by the flank.....	518	Ranges, classification.....	540
interval between skirmishers.....	519	Rapid fire.....	539, 544
kneel or lie down.....	522	Regulating intensity of fire.....	544
of fire discipline.....	534	Rushes.....	556
of fire discipline, departures from.....	535	Scouts, to fire.....	535
posts of squad leader... 513, 517, 520, 527, 528	510	Sharpshooters, and individual men, firing.....	536
Instruction on varied ground.....	547-557	Signals, use of... page 7...	533
		Skirmishers, assemble.....	532
		Use of cover.....	551, 557
		Volley firing.....	537, 543

THE PLATOON.

Assemble.....	566, 576	General rules:	
Change direction or front..	570	composition of firing-line.....	559
Chief of platoon, post and duties, general rule.....	559	designation of center squad.....	559
Corporal, posts.. 510, 513, 517, 520, 527, 528, 559, 572	572, 528, 559, 572	designation of point of direction.....	559
Deploy skirmishers, from line and line of squads..	563, 564	marching by flank under fire.....	559
Deploy platoon as skirmishers.....	564	movements of support..	559
Designation of center squad and point of direction.....	559	posts and duties of chief of platoon.....	559
Different formations for squads.....	567	posts and duties of chiefs of sections....	559
Firing line, composition, general rule.....	559	posts and duties of corporals. 510, 513, 517, 520, 527, 528, 559, 572	
Firings.....	572, 573	support.....	559

THE PLATOON—Continued.

	Pars.		Pars.
Intervals, increase and diminish.....	565	Line of squads, to the front, from column of fours	561
Intervals in line of sections	574	Marchings.....	568-571
Intervals in line of squads..	560	Rally	576
Line of sections, movements same as line of squads.....	574	Re-enforcement of firing line.....	575
Line of skirmishers, from line of squads.....	563	Section constituting firing line.....	573
Line of skirmishers, from platoons in line.....	564	Section, movements of, like platoon.....	574
Line of squads, from line..	560	Signals for execution of movements.....	page 7.. 533
Line of squads, on right or left, from column of fours	562	Support, general rule.....	559

THE COMPANY.

Advance 2,500 yards to enemy's position, offensive.....	583-593	Company in battalion, offensive.....	583-594
Arrival at position, defensive.....	597	Composition of firing line, defensive.....	596
Arrival of supports on firing line, offensive.....	589	Counter attacks, defensive.	597
Artillery, defense and attack of.....	599-601	Defensive dispositions ...	596, 597
Assembly.....	580	Deployment.....	580
Attack.....	583-593, 595	Designation of sections for firing line and support, offensive.....	583
Battalion reserve, defensive.....	596	Echelons.....	577
Battle formation.....	577	Extension, offensive.....	583
Battle formation defensive.....	596	Fighting front, company in battalion.....	577
Cavalry, action against....	598	Fire discipline, how maintained.....	591
Charge.....	593	Firing line, sections for....	579
Closing of firing line, offensive.....	587	Firings.....	580
Commanders of companies, duties of, respecting use of scouts.....	582	First volleys, offensive....	585
Company alone, defensive.....	578, 597	Form for attack, offensive.	583
Company alone, offensive.....	578, 595	General rule : reconnoissances and use of scouts.....	582
Company in battalion, defensive.....	596	Infantry under artillery fire.....	599
		Intervals, increase and diminish.....	580
		Line of squads or sections..	580
		Marchings.....	580

THE COMPANY—Continued.

	Pars.		Pars.
Movements following charge, offensive.....	593	Relieving the firing line, offensive.....	594
Movements same as platoon	580	Retiring from position, defensive.....	597
Offensive	583-595	Rushes	556, 588, 590, 592
Positions and duties of officers, etc	581	Scouts, use and duties of.....	582, 583, 585, 596, 597
Pursuit	595	Sections for firing line.....	579
Rally	580	Sections for firing line and support, offensive	583
Rapid fire, offensive.....	593	Supports all in firing line, offensive.....	593
Reconnoissances, general rule.....	582	Volleys, offensive	585-591
Re-enforcing firing line, defensive and offensive.....	592, 596		

THE BATTALION.

Advance guard of a regiment.....	614	Echelons.....	603
Against cavalry.....	616	Extension	604
Assembling and rallying...	607	Fighting front.....	604
Artillery, defense and attack of	617-619	Fighting line	603
Battalion alone, defensive..	612	Firing line.....	603
Battalion alone, offensive..	610	Formation for attack	604, 609
Battalion in action, general rules.....	608	General rules.....	608
Battalion in regiment, defensive.....	611	Intervals between companies in line of skirmishers.....	604
Battalion in regiment, offensive.....	609	Intrenchments.....	611
Color, in action.....	604	Marchings.....	605
Defensive	611, 612	Mounted officers.....	604
Designation of companies, etc., for fighting line and reserve	604	Night operations	620
Direction of advance.....	605	Offensive.....	609, 610
Discretion of commanders..	608	Operating on flank.....	613
Dispositions after assault, offensive.....	609	Patrols, defensive	611
Dispositions of a battalion.....	613-620	Position of reserve.....	604
		Post of major	604
		Principles of instruction....	602
		Rallying.....	607
		Rear guard of a regiment.....	615
		Relieving and re-enforcing firing line.....	606
THE REGIMENT			621

THE BRIGADE IN BATTLE.

	Pars.		Pars.
Discretion of commanders.....	626-629	Place of reserve, general rule.....	629
Fighting line, without regimental reserves.....	624	Position of brigade commander.....	627
Formations.....	622-626	Reserve formed in echelon.....	629
One line.....	623	Two or three lines.....	624, 625
Order from brigade to battalion commander.....	628	Withdrawing the brigade.....	630-631
Passing from close to extended order, general rule.....	629		
THE DIVISION IN BATTLE.....			632-635

CEREMONIES.

Battalion inspection.....	739-745	General rules for reviews—	
Battalion parade.....	733, 734	Continued.	
Battalion review.....	689-696	colonels and majors facing line to give commands.....	680
Brigade review.....	703-705	colonels and majors salute after resuming front.....	680
Company inspection.....	746	color salutes.....	498, 682
Corps review.....	709, 710	column passing reviewing officer, distance..	667
Division review.....	706-708	commanders draw and return sword when..	676
Details, at guard mounting, alternate in position.....	713	commanders take post in column, when.....	674
Escort of the color.....	754-757	commanders turning out of column.....	677
Escorts of honor.....	758	commands given or repeated by colonels and majors.....	679, 680
Field and staff senior to inspecting officer.....	740	companies brought to carry and right shoulder.....	667
Funeral escort.....	759-768	execution of commands repeated by majors..	680
General rules for ceremonies.....	663-666	field music sounds march, flourishes, or ruffles.....	684
arrangement of troops of different arms.....	663	flag and orderlies of reviewing officer.....	670
field and staff, when mounted.....	665	marking points where column changes direction, etc.....	667
non-commissioned officer commanding company or platoon.....	666		
posting of companies, battalions, etc.....	664		
General rules for reviews..	667-688		
after passing reviewing officer.....	687, 688		
bands, play, turn out of column, etc.....	683		
brigades at ease, etc....	678		
changing direction, passing in review.....	667		

CEREMONIES—Continued.

Pars.	Pars.
General rules for reviews— Continued.	General rules for reviews— Continued.
modifications of forma- tion for review..... 685	staff officers draw and return sword, when.. 676
officers and others ac- companying review- ing officer..... 669, 671	staff salute at command 680
orderlies of reviewing officer..... 670	Guard mounting..... 712-732
pass in review in quick time..... 690	Guard mounting, cavalry and infantry united..... 731
points where companies execute carry and right shoulder..... 667	Guard mounting, in bad weather, etc..... 730
repetition of commands by colonels..... 679	Guard mounting, interval between old and new guard..... 726
review by inspector junior to command- ing officer..... 696	Guard mounting, without review..... 725
reviewing officer, post of..... 668	Inspection, band..... 743
reviewing officer riding around troops, who accompany..... 672	Inspection, battalion..... 739-745
reviewing officer, sa- lutes..... 669	Inspection, enlisted men with sword drawn..... 497
review of command larger than corps.... 711	Inspection of a company. 742, 746, 747
salute by color..... 498, 682	Inspection, regimental.... 748-750
salute to color..... 669	Muster..... 751-753
salutes returned by re- viewing officer..... 669	Non-commissioned officer commanding guard.... 718, 727
sounding march, flour- ishes, ruffles..... 684	Officer of the guard, super- numerary..... 717
staff and orderlies when commander faces line to give commands.... 681	Officers of the day..... 722
staff, etc., of command- ers..... 675	Parade, battalion..... 733, 734
staff, etc., of command- ers turning out of col- umn..... 677	Parade, regimental..... 735-738
staff, etc., of reviewing officer..... 669, 670	Points where companies execute carry and right shoulder..... 667
staff, etc., passing around troops..... 673	Regimental inspection.... 748-750
	Regimental parade..... 735-738
	Regimental review..... 697-702
	Review, battalion..... 689-696
	Review, brigade..... 703-705
	Review by inspector junior to commanding officer... 696
	Review, corps..... 709, 710
	Review, division..... 706-708
	Review of command larger than corps..... 711

TRUMPET CALLS, ETC., pages 285-324, par. 769.

MISCELLANEOUS SUBJECTS, pages 3-7 and pars. 1-9, 485-501, 636-662.

	Pars.		Pars.
About face for officers.....	486	Enlisted men using about face for officers.....	486
Advance guard.....	614, 636-640, 644, 645	Field music, posts and duties of.....	256, 500
Definition..... page 5..	636	General principles, Infantry Drill Regulations.....	1-9
Modifications of rules...	645	Commands.....	6, 7
Strength.....	644	Formation for infantry.....	1
Band.....	256, 260, 369, 500, 501	Guide (right or left).....	3
Drum major, instructions for.....	501	Movements from halt or marching.....	4
Field music, posts and duties.....	256, 500	Movements in double time.....	5
Formation.....	500	Movements toward either flank, how explained.....	2
Inspection.....	743	Posts of officers and instructors.....	9
Marches, flourishes, ruffles, and to the color sounded by field music, when.....	500, 684	Signals and trumpet calls, use of, in instruction.....	8
Movements of band...500,	683	Honors to be paid by troops	662
Open ranks.....	500	Manual of sword.....	487-497
Posts of.....	256, 369	Carry sword, when used.....	492
Takes post, when.....	260	Enlisted men with sword drawn, at inspection.....	497
Camping.....	660, 661	Enlisted men with sword drawn, carry sword (or arms), from present.....	489
Color and color guard...254,	265, 498, 499, 604	Enlisted men with sword drawn, order sword (or arms), from carry.....	491
Color, escorted to and from color company .	499	Enlisted men with sword drawn, present sword (or arms).....	489
Color guard.....	499	Officers draw and return sword without command.....	495
Color guard, manual of arms.....	265		
Color in action.....	604		
Color, regimental, post of bearer.....	499		
Color, with battalion designated by colonel	499		
Manual of the color....	498		
Regimental color-bearer, post of.....	499		
Salute of color, when rendered.....	498, 682		
Courtesy among military men	485		
Definitions..... pages 3-6.			
Drill signals..... page 7.			
Drum major, instructions for	501		

MISCELLANEOUS SUBJECTS—Continued.

	Pars.		Pars.
Manual of sword—Cont'd.		Marches	651-658
Officers mounted, draw and return sword ...	487, 493	Outposts	646-650
Order sword, when executed	491	Rear guard	615, 641-645
Position of sword at double time.....	494	Defined	page 5.. 641
Position of sword marching at ease and at route step.....	246	Modifications of rules	645
Position of sword while marching, etc.....	492	Strength.....	644
Sword, while publishing orders	488	Respect to superiors.....	485
		Rifle salute	95, 485
		Salute with hand	29, 485
		Signals for drill movements	page 7..
		Use by enlisted men of about face for officers	486

DISTANCES.

Definition	page 3.	Echelon, between battalions	457
Band, between ranks	500	Firings	536-539
Band in column	256, 369	Forming line, between guides	257
Band, open ranks	263, 500	Guides, posting of, successive formations	288
Classification of ranges	540	In mass	334
Close column	334	File closers	page 4.. 334
Column, band	256	Open ranks	190, 263
Column of battalions	385	Platoon, between firing line and support	559
Column of companies, full distance	298	Ranges, classification	540
Column of files	131, 215	Reserve in rear of supports, battalion	604
Column of fours, between battalions	382	Route step, between ranks	245
Column of fours, between companies	282	Saluting distance	485
Column of fours, between ranks	196	Successive formations, guides from flank or head of column	288
Column of masses, between battalions	410	Two or more lines, between lines, brigade	465
Column of platoons, between platoons	226	Two or more lines, between lines, division	483
Column of subdivisions	298	Two or more lines, between lines, regiment	385
Column of twos	214	Unslung and sling knapsacks	98
Company in extended order, between echelons	577		
Corporal in front and rear, extended order	520		
Drum major in front of band	501		

INTERVALS.

	Pars.		Pars.
Definition	page 5.	Line of companies or platoons in columns of fours.	409
Band, battalion in line	256	Line of masses, between battalions.....	371
Band, between files	500	Line of platoon columns, between battalions.....	454
Band, regiment in line	369	Line of platoon columns, close and full.....	354
Bayonet exercise	152-156	Line of platoons in columns of fours, between platoons.....	237
Column of fours, twos, or files, file closers	197	Line of sections, between sections.....	574
Color bearer, from flank of color company	254	Line of skirmishers, between companies.....	604
Guard mounting, between old and new guard	726	Line of skirmishers, between skirmishers.....	519
In ranks	19, 122, 189	Line of squads, between squads.....	560
Line, band	256, 369		
Line, between battalions ...	371		
Line, between brigade	482		
Line, between companies ...	257		
Line, between regiments ...	462		
Line of columns, band	256		
Line of columns of fours, between companies	320		

GENERAL RULES AND RULES OF GENERAL APPLICATION.

About face for officers, use of, by enlisted men	486	Arrangement of troops of different arms, etc	663
Adjust sight, before aiming	534	"As you were"	17
Adjutant and sergeant-major assure guides for close column	337	Attention, in extended order	506
Adjutant and sergeant-major, when guide in column is changed	300	Back step from order	112
Advance guard	614, 636-640, 644, 645	Band and field music, posts of	256, 260, 369
After passing reviewing officer	667, 687, 688	Bands play, turn out of column, etc., at review	683
Aim	534	Band takes post in line, when	260
Alignments	112, 122, 189, 279, 280, 380, 509	Base company, extended order	604, 609
Alignments in extended order	509	Base file, skirmisher, or guide, extended order ...	515, 516, 520, 521
Announcement of guide, changing direction, column of subdivisions	228	Base squad, extended order	559, 583
		Basis of extended order ...	502
		Battalion awaiting completion of movement	370

GENERAL RULES, ETC.—Continued.

	Pars.		Pars.
Battalion in action....	602, 608, 608	Close column, deployments.....	346, 347
Battalion in fighting line...	621	Close column, distance between companies.....	334
Battle exercises.....	113, 558	Close column, file closers..	334
Blank cartridges in battle exercises.....	558	Close column, leading or designated company in front.....	337
Boxes closed after executing order or order kneeling.....	79	Close column, movements same as in column at full distance.....	343, 345
Brigades at ease at review.	678	Close column, ployments...	337
By the numbers.....	48	Close ranks from order....	112
Cadence of motions in manual.....	47	Colonels and majors, facing line to give commands at review.....	680
Captain, at command "guide center".....	272	Colonels and majors salute at review, when.....	680
Captain, dressing company in line.....	258	Color escorted to and from color company.....	499
Captain, in alignments.....	189	Color guard in loadings and firings.....	265
Captain, in column of fours, twos, or files.....	197	Color, in extended order...	604
Captain, in loadings and firings.....	193, 266	Color salutes, when.....	498, 682
Captain, in turn and halt..	192	Column of battalions, distance.....	385
Cartridges, use of.....	94	Column of files.....	117, 131, 215
"Cease firing, load," use of.	149	Column of fours in regiment, movements explained from march.....	384
Cease firing, when command may be given.....	148	Column of masses, distances and ployment.....	410
Center of company changed to flanks.....	247	Column of subdivisions, full distance.....	298
Ceremonies (see general rules, under ceremonies).....	663-666	Commanders draw and return sword at review....	676
Change of guides to line of file closers and reverse...	247	Commanders, in extended order, use of scouts.....	582
Changing direction, passing in review.....	667	Commanders take places in column at reviews, when.....	674
Chief leaving post in extended order.....	510	Commanders turning out of column at review.....	677
Chief of platoon in extended order.....	559	Command "fire," when given.....	146
Chief of sections, forming line of squads or skirmishers.....	559	Commands.....	6, 250, 370
Chief of subdivision in column, alignments.....	189		
Chief of subdivision in column, takes post when....	220		

GENERAL RULES, ETC.—Continued.

	Pars.		Pars.
Commands, by chiefs of platoons.....	220	Disengaged hand at double time.....	112
Commands for firings.....	143	Distance between ranks.73, 98, 110	
Commands given by trumpet repeated orally.....	769	Distance leading four, subdivision, etc., advances before halting.....	209
Commands, intervals between, in firings.....	146	Distances in close column..	334
Commands repeated at reviews.....	679, 680	Distances in column of subdivisions.....	206
Commencement of instruction, extended order.....	503	Double rank, habitual formation, for infantry.....	1
Commencement of instruction with arms.....	44	Double time taken by battalion, after passing reviewing officer.....	687
Companies brought to carry and right shoulder at review.....	667	Dress, in column of fours..	199
Company, extended order.....	577-580	Dressing in extended order.....	509
Composition of firing line, extended order.....	559	Echelon, definition and use of term..... page 4, 577, 608	
Corporal, as squad leader..	115	Enemy imaginary, outlined, represented.....	505
Corporal, in extended order.....	115, 510, 513, 515-517, 520, 522, 527, 528, 559, 572	Enlisted men in line of file-closers, manual of arms..	193
Correction of errors.....	17	Evening gun.... page 286..	769
Courtesy among military men.....	485	Execution of movements at signals, extended order.511, 512	
Departures from general rules for fire discipline...	535	Exercise of squad, in extended order.....	514
Deployment as skirmishers.....	521	Explanations made for double rank.....	114
Deployments forward and by the flank, extended order.....	518	Extended order from any formation.....	507
Deployments of close column.....	346, 347	Extended order, positions of piece.....	106
Deployments of column of masses.....	419-423	Face to the front in extended order, when.....	508
Designation of base company, extended order....	604	Facings, from order.....	112
Designation of center squad and point of direction.....	559, 583	Fall in.....19, 20, 120, 187	
Detachments, details, etc., movements of.....	192	Field and staff at ceremonies, when mounted, etc.....	665
Discretion of commanders.....	608, 621, 629	Field and staff officers, mounted.....	255
		Field music sounds march, flourishes, ruffles, and to the color.....	500, 684
		Fighting line.....	608, 621

GENERAL RULES, ETC.—Continued.

	Pars.		_ ARS.
File closers, duties and responsibility.....page 4..	248	General principles, extended order.....	502-510
File closers, in close column.....	384	General principles, Infantry Drill Regulations.....	1-9
File closers, in column of fours, etc.....	197	Grouping of company into squads.....	179
File closers, manual of arms.....	193	Grouping of recruits.....	16, 115
Fire, at objective.....	534	Guard mounting.....	712-732
Fire at will.....	538	Guard mounting, cavalry and infantry united.....	731
Fire discipline.....	534, 535	Guard mounting in bad weather, etc.....	730
Fire discipline, how maintained in extended order.....	591	Guard mounting, interval between old and new guard.....	726
Fire, when.....	534	Guard mounting, open ranks.....	714
Fire with counted cartridges.....	538	Guard mounting, supernumeraries.....	713
Firing line.....	559	Guard mounting, without review.....	725
Firing, pending completion of successive formation.....	288 (m)	Guide, announcement of.....	136, 228, 251
Firings.....	142-144, 146, 541-546	Guide, forming line from column of platoons.....	231
Firings by battalion, etc....	268	Guide, in oblique marching.....	136
Firings, executed at halt....	542	Guide, in turn and halt.....	192
Firings, extended order, duties of instructor.....	541	Guide of second or rear platoon in column.....	226
Firings, extended order, volleys.....	543	Guide of squad, in extended order.....	515, 516
Firings, in regiment.....	373	Guides and enlisted men in line of file closers, manual of arms.....	193
First sergeant, position of..	247	Guides, in alignments.....	189
Flag and orderlies of reviewing officer.....	670	Guides, in column of fours, twos, or files.....	197
Flanks of company changed to center.....	247	Guides, in column of subdivisions, duties of.....	300
Formation, advancing considerable distances.....	275	Guides, in forming close column, how assured.....	337
Forming line by two movements, command "march".....	293	Guides in front marking line.....	193
Forward march, on completion of wheel by fours.....	199	Guides, in successive formations, when firing is to commence.....	288 (m)
Four.....	180, 181		
Fours wheel about toward point of rest, forming line faced to the rear.....	292		
Full distance, column of subdivisions.....	298		

GENERAL RULES, ETC.—Continued.

	Pars.*		Para
Guides, manual of arms....	193	Habitual formation of regiments and battalions moving into position.....	464
Guides marching at route step and at ease.....	319	Halting leading subdivision at less than prescribed distance.....	209
Guides of platoons or subdivisions, at command "front".....	189	Hammer at safety notch....	49, 70
Guides of rear companies, forming line by two movements.....	293	Honors to be paid by troops	662
Guides of subdivisions in column.....	189, 300	Indication of objective and range.....	146
Guides, position of piece ...	193	Individual men and sharpshooters, ranges.....	536
Guides, posting of, by themselves.....	288(k)	Inspection, band.....	743
Guides, posting of, distance.....	288(g)	Inspection of quarters.....	745
Guides, posting of, formations front into line.....	288(d)	Instruction in extended order, to commence, when.....	503
Guides, posting of, formations into line.....	288(a)	Instruction of officers, etc.	185, 252
Guides, posting of, formations into line faced to the rear.....	288(i)	Intensity of fire, how regulated.....	544
Guides, posting of, formations on right or left into line.....	288(c)	Interval and distance, in bayonet exercise.....	152-156
Guides, posting of, in changes of front.....	288(f)	Interval in line, how taught.....	19, 122
Guides, posting of, in deployments.....	288(e)	Intervals between battalions.....	371
Guides, posting of, in forming line of masses.....	432	Intervals between battalions, full and close.....	409
Guides, posting of, prolonging line.....	288(h)	Intervals between brigades.	482
Guides, posting of, successive formations of regiment.....	385	Intervals between companies in battalion.....	257
Guides, posting of, time of.....	288(b)	Intervals between companies in line of skirmishers.....	604
Guides, recovering direction.....	300	Intervals between regiments in brigade.....	462
Guides take post.....	189	Intervals between skirmishers.....	519
Habitual formation advancing considerable distances.....	275	Intervals in line of platoon columns.....	354, 454
Habitual formation for infantry.....	1	Intervals in line of sections.....	574
		Intervals in line of squads..	560
		In two lines, position and movements of second line.....	886

GENERAL RULES, ETC.—Continued.

	Pars.		Pars.
Kneel or lie down, extended order.....	522	March taken up on completion of wheel by fours.....	199
Leading four or subdivision, where halted.....	209	Marking points where column changes direction, etc., in reviews.....	667
Length of drills.....	11	Measuring distances and intervals, pages 3 and 5...	
Length of steps.....	31, 34, 37-39	Memorizing drill signals, page 286,	769
Line of masses.....	432	Modifications of formation for review.....	685
Line of platoon columns, movements.....	355, 357, 364	Morning gun.....	page 286, 769
Load, when.....	534	Mounted officers, about.....	255
Loose pieces.....	100	Mounted officers, draw and return sword.....	487, 496
Maintenance of squad, extended order.....	502	Mounted officers, in extended order.....	604
Major commands "guides posts" on completion of successive formations into line.....	288(1)	Mounted trumpeters and orderlies.....	369, 463
Majors, forming line of columns of fours, in regiment.....	399	Movements by battalions, simultaneous and separate.....	370
Major, in loadings and firings.....	265, 266	Movements by companies or platoons, simultaneous.....	251
Manual of arms:		Movements by platoons in battalion.....	348, 351
battle exercises.....	118	Movements by platoons in regiment.....	454-456
color guard.....	265	Movements by platoons same as by companies....	331
guides and enlisted men in line of file closers.....	193	Movements executed at signals, extended order.....	511
hammer at safety notch marching and halting..	49, 70	Movements executed by company as in School of the Soldier.....	192
open chambers.....	46	Movements executed by platoons, etc., as in School of the Soldier.....	192
piece in front of body..	49	Movements executed from halt or marching.....	4
position of thumb.....	49	Movements in double time..	5
resume carry, last motion.....	49	Movements in extended order, commence when....	506
when marchings, etc., are understood.....	112	Movements in extended order, first instruction.....	503
March and stand at ease.....	246, 509		
March at ease and route step.....	246, 319		
Marching, by the flank under fire.....	559		
Marching with arms, recruits.....	111		
March in review at quick time only, except for single battalion.....	686		

GENERAL RULES, ETC.—Continued.

Pars.	Pars.		
Movements in extended order made with reference to enemy.....	504	Non-commissioned officer commanding company at ceremonies.....	666
Movements in line of columns of fours in regiment.....	399	Non-commissioned officer commanding detachment, etc., position of rifle.....	193
Movements in single rank for instruction.....	114	Non-commissioned officer commanding company, post of.....	259
Movements in which guide may be either right or left.....	3	Non-commissioned officer commanding guard.....	718, 727
Movements of battalion like company.....	269-286	Objective, firings.....	142, 146
Movements of brigade on same principles as regiment.....	464	Object of bayonet exercise.....	151
Movements of column of masses like column at full distance.....	417	Officer of the guard, supernumerary.....	717
Movements of column of platoons.....	224	Officers and others accompany reviewing officer..	669, 671
Movements of company like squad.....	192	Officers of the day.....	722
Movements of division on same principles as brigade.....	479	Open chambers.....	46
Movements of line of platoon columns.....	357	Open ranks, at order.....	112
Movements of line of sections like line of squads.....	574	Order from brigade to battalion commander.....	628
Movements of masses like regiment in line.....	441	Orderlies and trumpeters mounted.....	369, 463
Movements of regiment in column of fours explained from march.....	384	Orderlies of reviewing officer.....	670
Movements of regiment in column of fours like battalion.....	383	Order of arrangement of troops.....	663
Movements of regiment like battalion.....	399, 401, 409	Order of instruction, School of the Soldier.....	15
Movements of second line in regiment.....	385	Orders of brigade commander.....	465
Movements of support, extended order.....	559	Orders of division commander.....	483
Movements toward either flank.....	2	Order, upon halting.....	112
		Passing from close to extended order, the brigade	629
		Pass in review in quick time.....	686
		Piece in front of body.....	49
		Pivot, fixed and movable.....	196, 197, 200
		Place of captain dressing company.....	258
		Place of reserve.....	629
		Platoons.....	179-183, 192

GENERAL RULES, ETC.—Continued.

	Pars.		Pars.
Platoon column.....	354	Review by inspector junior to commanding officer...	696
Platoon column, full and close intervals.....	354, 355	Reviewing officer, post of..	668
Platoon, extended order....	559	Reviewing officer, riding around troops, who accompany.....	672
Ployment of column of masses.....	410	Review of command larger than corps.....	711
Ployments of close column.....	334-341	Reviews (see general rules for reviews, under ceremonies).....	667-688
Points where companies execute, carry and right-shoulder, at review.....	667	Rifle salute.....	95, 485
Position of the soldier.....	21	Right shoulder, at command "double time".....	112
Position of thumb, manual of arms.....	49	Riding around troops, staff, etc., of reviewing officer.....	672, 673
Positions of piece for extended order and route marches..	106, 113	Route marches, positions of piece.....	106
Positions of piece, recruits.....	111	Rushes.....	556, 588-590, 592
Posting of companies, battalions, etc., for ceremonies.....	664	Salute by color.....	498, 682
Posts of officers, etc., as instructors.....	9	Salute color by uncovering.	669
Practice in giving commands.....	7	Salutes returned by reviewing officer.....	669
Precedence of troops.....	663	Salute to the color, in reviews.....	669
Principles of extended order.....	502-510	Salute with hand.....	29, 485
Ranges, classified.....	540	Salute with rifle.....	95, 485
Rapid fire.....	539, 546	School of the soldier:	
Rear guard.....	615, 641-645	correction of errors.....	17
Rear rank close, loading and firing.....	77, 144	grouping of recruits....	16
Reconnoissances and use of scouts.....	582, 611	instructors.....	12, 14
Regulation of progress of action.....	608	length of drills.....	11
Re-enforcement of firing line.....	575, 592, 596, 609	object.....	10
Relieving the firing line....	594	order of instruction....	15
Repetition of commands... ..	250	Scouts, use and duties of.....	582, 583, 585, 596
Repetition of commands given by trumpet, page 286,	769	Sections.....	179-183
Reserve, posting of.....	629	Section constituting firing line, extended order.....	573
Respect to superiors.....	485	Sharpshooters, firing in extended order.....	536
		Side step from order.....	112
		Signals and trumpet calls, practice.....	8
		Signals, use of.... page 7..	506, 533

GENERAL RULES, ETC.—Continued.

	Pars.		Pars.
Simultaneous movements by battalions	370	Staff of colonel, brigade commander, etc., salute at review, when	680
Simultaneous movements by companies or platoons	251	Staff officers draw and return sword, when	676
Single rank, used in first instruction.....	114	Staff officers of brigade commander	463
Sounding calls page 286,	769	Staff officers of colonel.....	369
Sounding of march, flourishes or ruffles at review..	684	Staff salute at command ...	680
Squad	180, 181	Stand and march at ease, in extended order.....	509
Squad, extended order	518-522	Successive formations.....	288, 385
Squad leader.115, 510, 513, 515-517	520, 522, 527, 528, 559, 572	Support, extended order....	559
Squad leaders, how re-placed	502	Swing of arms.....	192
Squads, when broken up...	502	Sword, position of, marching, etc.....	492
Stacks to be made with stacking swivel.....	99	Sword, position of, at double time	494
Staff, etc., of commanders, at review.....	675	Sword, when drawn and returned by officers.....	495
Staff, etc., of commanders turning out of column at review	677	Sword, while publishing orders.....	488
Staff, etc., of reviewing officer	669, 670	Troops return to camp, etc., after review.....	667, 687, 688
Staff, etc., riding around troops at review.....	673	Two or more lines, in regiment, distance.....	385
Staff, etc., when commander faces line	681	Volleys, use of.....	537, 543, 591
		Wheels by fours on fixed pivot.....	197

INTERPRETATIONS

OF THE

INFANTRY DRILL REGULATIONS.

[ADDENDA.]

INTERPRETATIONS

OF

Infantry Drill Regulations

UNITED STATES ARMY

Published in the Army and Navy Journal, in answer to inquiries, and revised by their author, 1st Lieut. John T. French, Jr., 4th Art., U. S. Army, Recorder of the Board on the revision of the Tactics, Lieut.-Col. John C. Bates, 20th Inf., U. S. Army, President.

W. C. & F. P. CHURCH
NEW YORK

These interpretations were originally published in the *Army and Navy Journal*. I have revised them for separate publication, making such corrections as have been shown to be necessary for clearness and accuracy.

The numbers of paragraphs correspond to those of the *Infantry Drill Regulations*.

J. T. FRENCH, JR.,

1st. Lt. 4th Art'y, U. S. Army.

Students of the Drill Regulations, desiring information on other points, should address their inquiries to the "Army and Navy Journal," New York, in which these decisions originally appeared.

EDITOR "ARMY AND NAVY JOURNAL."

INTERPRETATIONS.

Par. 1. Does not provide for formation or drill of any kind in single rank, except for instruction of recruits, or for special purposes, as in Par. 186. Pars. 18, 45, 114, 119 and 186 prescribe the departures from the rule laid down in Par. 1; see also last clause of the order adopting the Drill Regulations.

Pars. 18 and 19. The interval between files is not measured in inches; it varies with the individual, and is always measured as stated in Par. 19; it is simply an interval that allows a free movement of the arms.

Par. 24. The fingers of the left hand simply clasp those of the right, without constraint; they are not tightly closed, nor are they extended and joined.

Par. 30. The recruit is not expected to learn each of the settings up exercises by the name "First Exercise," etc.; the commands indicate in each case what is to be executed. "First Exercise" is not a command, but is the name of a movement. In the trunk exercises, the commands *Down, Right, Circle right, or left*, and in the leg exercises *Half-bend, Full-bend, Left or Right, Forward and Up*, indicate better than any caution "Eighth Exercise," etc., what is to be executed.—Third exercise. At the command *circle*, slowly describe one circle with each arm; to cause the recruit to describe another circle, repeat the command *circle*, and so on.—Eighth to Tenth Exercises. Palms of hands should be on hips.—Twelfth Exercise. At the command *raise*, the arms are raised to the front until horizontal, hands in front of the shoulders, palms down. At the command *down*, bend the t
forward at the hips and at the same time swing the

arms *vertically*, not *horizontally* as in the Second Exercise; the hands should move downward, then backward and upward, so that at the end of the motion the hands are back of the shoulders and a little above them, the arms being kept fully extended.

Par. 35. The squad may be halted from double time without first coming to quick time.

Par. 36. Movements are explained according to their uses, from the halt, if that is habitual, or from the march, as the case may be. Mark time, as a separate movement from a halt, is not considered of any use, but there are cases in which, as part of a movement that has a cadence of its own, mark time from a halt is useful, for example, in wheeling on a fixed pivot (Par. 196) from a halt.

Par. 45. The word "file" requiring substitution of "man" does not occur in the manual of arms.

Par. 46. At the formation of the company, the captain has chambers opened as he may see fit.

Par. 47. The execution of order arms from ready, involving, as it does, bringing the hammer to the safety notch, should be executed with promptness and regularity, but, as a complete movement, not in the cadence. See last four lines of the paragraph.

Par. 48 is a general application, but applies more particularly to the manual of arms. Drilling by the numbers, if the command *Fall out, rest, or at ease*, be given, the caution *by the numbers* should be given to continue the numbers after resuming attention.

Par. 49 (2d). At the port and charge bayonet, the thumb of the left hand clasps the piece; the position of the thumb with reference to the sight is not specified; this will depend upon the size of the man's hand, and the shape and position of the sight, the left hand being at the balance.

Par. 49 (3d). This applies only to present arms.

Par. 50. At order arms, the third and fourth fingers are held in rear of the piece, in the most natural manner.

Par. 52. The left hand while steadying the piece is above the right.

Par. 53. Present arms is prescribed only from a carry.

Par. 54. At the end of the first motion, the body of the hand, not the point of the thumb, should be at the height of the chin.

Par. 56. The piece should be lowered with the left hand, regrasped with the right above the left, and the left hand then placed above the right.

Par. 57. The left hand should grasp the piece at the balance, whether the rear sight is at that point or not. Plate 7 shows the position of the hands in Port arms, "palms up and palms down." Port arms from the order should be executed in one motion. Order from port is executed in two motions; the commands should be (if by the numbers): 1. *Order.* 2. ARMS (two).

Par. 58. Right shoulder from port is executed in two motions; the commands should be (if by the numbers): 1. *Right shoulder.* 2. ARMS (two).

Par. 60. The heel of the butt remains on the ground, the piece turning in the hand so as to bring the barrel to the left.

Pars. 62, 63. The barrel of the rifle is to the front.

Par. 63. Returning to order from fix bayonet, the position at the end of the first motion is the same as from the carry. The second motion is the same as from the carry.

Par. 64. The piece is brought from the port to unfix bayonet using the left hand alone. Fix bayonet from port is not prescribed.

Par. 67. No provisions are made for any special movement of the rear rank as a matter of formal drill. See last clause of Par. 113.

The feet are nearly parallel in the position described. The rear rank charges bayonets as prescribed in this paragraph. Bending the knee at charge bayonet is not prescribed.

Par. 68. Execute in one motion.

Par. 69, etc. Movements in the manual of arms from Par. 69-82, 85-94, 96-105, are not intended to be executed in column of files.

Par. 69. The right hand should rest on the thigh in a natural position, back to the right.

Par. 71. Order kneeling is executed without moving piece. "Resting the weight of the body on the right heel" is the same thing as sitting on the right heel.

Par. 72. The rear rank men rise and cover their file leaders at facing distance.

Par. 73. In the rear rank the men, without rising, move back thirty inches in the most convenient manner, and then lie down. The muzzle should not be allowed to touch the ground. "Inclining the body about thirty-five degrees to the right," means that the line of the body from foot to head forms an angle of thirty-five degrees with the original line of battle (or of formation) of the squad.

Par. 74. The rear rank simply cover their file leaders at facing distance, on rising.

Par. 76. The rear rank take the position kneeling, and then move forward thirty inches, in the manner most natural, but without rising.

Par. 77. All that is prescribed in the paragraph is executed in one motion. It is not proper to divide the "load" into motions.

Pars. 77 and 80. The carry is not the habitual position from which *load* or *ready* is executed, but rather the order, and coming from load or ready to the carry is not prescribed. "Planting the toe opposite the middle of

the interval to his right and *in line with the left heel of his front rank man*," means that the toe should be carried as far front as the line of left heels of the front rank. The position of the right foot prescribed for the front rank man in loading must be such as not to interfere with the position of the left foot of the rear rank man; in most cases, if the left foot of the rear rank man is properly placed, there will be no interference. Cartridge boxes are opened when necessary, *i. e.*, when a cartridge is to be taken out or replaced. In instructing a squad in the method of loading, it is not customary to cause the box to be opened at all; the hand is merely passed back to the cartridge box as if to take a cartridge. If the cartridge belt is worn, the recruit takes the cartridge from the belt. No preparatory command precedes *load*, except as provided in Par. 94.

Par. 79 and 144. No change in the habitual position of the cartridge box has been made. Under Pars. 79 and 144 the cartridge box is slipped around to the right far enough for convenience in reaching the cartridge. After the piece is loaded, brought to order arms and cartridge box closed, and the command *ready* is given, the cartridge box is not opened.

Par. 81. Pieces can be carried to any position from ready whenever necessary. See Par. 113.

Par. 82. From the position of load, the rear rank step off as is most convenient in resuming their places at the command *order* or *carry arms*.

Par. 82. Hammer is brought to safety notch at the command "*arms*." The piece should not be brought to the order with the sight raised. The command *cease firing* (Par. 147) should be used, or the instructor should have the sights laid down before commanding "*Order arms*."

Par. 84. After *draw cartridge* is executed the pieces are returned to the order by command.

Par. 85 and 90. The plates do not show the right thumb to be extended along the stock; the thumb should point in the direction of the muzzle. In this connection see Blunt's Firing Regulations, Par. 67.

Par. 90. The line of the piece is at an angle of about thirty-five degrees to the line of the body.

Par. 91. Both ranks change the position of the feet as prescribed in Par. 77, and the pieces are brought in the most direct manner to the position for loading, that is, the muzzle lowered, the barrel sloping downward at an angle of about twenty-five degrees; then the sights are adjusted and the muzzle raised. In first instruction, to which Pars. 77 and 91 apply, it is not contemplated that the pieces shall be loaded. See Par. 94.

Par. 97. The men fix bayonets, return to the order, and then open boxes. After inspection, the bayonet is un-fixed, and the piece returned to the order. (In this connection, see Par. 64.) Port arms, executed as in Par. 57, the "barrel sloping to the left, and crossing opposite the middle of left shoulder," gives the piece less inclination to the left than was prescribed in Upton, and the man next on the left should be at the interval taken, as prescribed in Par. 20, and not, as in Upton, closed until elbows touch. The piece, held at port as prescribed, should not be in the way of the man next on the left when he executes port from order, if he executes the port properly. Nothing is prescribed as to how the Inspector shall seize the piece or return it after inspection; the soldier receives it with the left hand at the balance (see eighth line), resumes the port, etc. The port must be resumed, but there is no distinct pause necessary after taking that position. Resuming the port involves grasping the small of the stock with the right hand.

Par. 98 was intended to apply generally to all kinds of packs, and anything in the paragraph that does not apply to any particular kind of pack should simply be left out.

Par. 98 provides for placing the knapsacks where they may be left while the men are needed in light marching order, or when going into camp.

See the definition of facing distance, page 4, and last clause of Par. 118. These make the distance between ranks 46 inches, besides the depth of the knapsack. For unslinging knapsacks at inspection, see Par. 742.

Par. 99. Whenever the pieces are stacked for any purpose other than instruction, "stacks will not be made with the bayonet if the rifles have the stacking-swivel."

Par. 100. Stack arms is prescribed from order only. ¹

Par. 106. Returning to carry, order, or any other position in the manual from either of the positions named, should not be reduced to regular motions or cadence.

Par. 109. The sling arms prescribed requires that the strap shall be secured to the rifle at about eight inches below the upper band. The arm may be placed between the parts of the sling or between the sling and the rifle.

Par. 110. Secure arms may be taken from any position

Par. 112. (1st.) Being at the order, at the command "Forward," or any preparatory command for marching in quick time, the pieces are brought to the right shoulder, the same as if the command had been "Right shoulder, arms." The preparatory command for marching in quick time, is the command given by chiefs of platoons when a company is executing platoon movements. (2d.) Double time may properly be executed with the piece at the left shoulder without changing position of the piece. The rule for changing to right shoulder applies only when the piece is at the order of carry. (3d.) Upon halting, pieces are brought to the order from the right shoulder, left shoulder or trail; if in any other position, they are not changed on halting. Halting, pieces at left shoulder: The piece is shifted in the most convenient

manner; reducing the movement to regular motions and cadence is prohibited. Officers, on halting, should come to the order whenever the men do. (4th.) The first motion of the order is executed at the command "*halt*" (or whatever determines time of halting), as if the command were "*order arms.*" The halt is executed at the same command, and at the same time, in the manner prescribed in Par. 33. There is no authority for including *port* and *carry* in the positions from which the piece is brought to the order on halting. Marching at a carry, if the command "*Halt*" is given, the men remain at the carry. It is proper to march at port arms. If marching at port arms, pieces remain at port on halting. (5th.) In the alignments the pieces are brought to the order as soon as the men arrive on the line, each man bringing his piece down as soon as he is correctly aligned, and without waiting for the command "*Front.*"

Pars. 119 and 186. Each man should raise his piece to the trail while in motion and resume the order on halting.

Par. 123. The base files established by the instructor include both front and rear rank men; the men in both ranks dress on them. In all cases where it is prescribed that the men turn the head and eyes to the right or left it is for the purpose of dressing toward the point indicated. When ranks are opened, it is by no means unusual that the base file of the front rank is moved forward or back, and the front rank always dresses.

Par. 130. For distance between ranks see Pars. 118 and 245. The uses of "*route step*" and "*double time*" are such that they involve marching more than a few paces, hence, in a company drill they would not be proper movements when the rear rank is in front (see Par. 212). In the squad drill, there are no fours to be considered, and no such restriction is prescribed; but *route step* is not a part of the instruction of the squad. To march to the rear in double time the command *march* should be given

as the right foot strikes the ground. At the command **march**, turn to the right about, etc.

Par. 133. The radius of about eighteen inches is needed to prevent crowding upon the pivot man while his step is shortened.

Par. 135. If executed from a halt, half face and step off at same time. In halting from the oblique, the men halt faced to the front and (Par. 112, 4th) execute the first motion of the order, all at the same time.

Pars. 140, 190 and 221. In each of these movements the men dress to the right or left, and Pars. 189, 121-126 explain how this is executed by the men in ranks. The same applies to all movements in which the men align themselves and execute *front* together. See interpretation of Par. 189.

Par. 140. Each man brings his piece to the order on halting, if at the right shoulder, left shoulder, or trail. The "right file" means the two men, front and rear rank, on the right. (See definition of file, page 4.) In the squad, there is no guide in the sense in which the non-commissioned officers on the right and left of a company are so designated (see Par. 116). In the company, the "right file" means No. 1, front and rear rank, of the first four. In the turn and halt, Par. 140 prescribes what the pivot file front rank man does, and also how the others in the squad conform to his movement. Par. 192, last three lines, prescribes what the guide, in the company, does in the same movement.

Pars. 140, 141. The turn is executed without changing the cadence of the step, unless the command be "double time," moving from a halt or quick time; from a halt, without the command "double time" it would be executed in quick time.

Par. 141. At the command, 1. *Right turn*, 2. *Double time*, 3. **MARCH**, the whole squad takes the cadence of double time, each man shortening his step to eighteen

inches when he arrives on the new line. The guide takes the short step without changing the cadence. See fifth line. The guide may be announced on either flank on the completion of the turn.

Par. 144. Par. 77 does not call the movement of the rear rank "closing," but to execute what is explained in Par. 77, the rear rank does close, and the rear rank does the same in Par. 144, at the preparatory command for firing.

Par. 144 applies whether the pieces are loaded or not. The rear rank take the position prescribed in Par. 77. The position of the pieces, front and rear rank, should be the same after as before the rear rank men close. See Par. 112 (5th).

Pars. 144, 145 and 159. The commands 1. *Fire by squad*, 2. *At* (such an object), 3. *At* (so many) *yards*, 4. *Squad*, 5. READY, 6. AIM, 7. FIRE, 8. LOAD, are executed as follows: *Fire by squad*; the rear rank men close, etc., as prescribed in Par. 144. *At* (such an object); the men look at the object (Par. 91). *At* (so many) *yards*; the men adjust their sights and look at the object again (Par. 91). READY (Par. 80). AIM (Par. 85). FIRE (Par. 86). LOAD (Par. 77). The position of the piece, at the command "Fire by squad," is changed only as indicated in Par. 112.

Pars. 144 and 145. "Fire by company" is "a preparatory command for firing."

Par. 145. Pieces are supposed to be loaded before using the commands prescribed in this paragraph; the command for this purpose would be LOAD, or 1. *With dummy (ball or blank) cartridges*; 2. LOAD.

Pars. 145 and 146. The range must be indicated in the preparatory command, whether within or beyond point blank.

Pars. 145 and 534. In close order, pieces are always

loaded at the command *load*, applying Par. 94. In extended order, Par. 542 applies.

Par. 149. The changing "to another method of firing" in this paragraph is such a change as from volley firing to firing at will, but not changing to another position. Under Par. 113, the command "kneel" might be given without stopping the firing. The boxes are opened whenever necessary either for the purpose of taking or replacing a cartridge, and they are opened for such a purpose in the simplest and most direct manner. It is proper to give *Cease firing, Load*, when firing by company.

Pars. 153, 154, 155 and 156. In the movement of the rear rank (Par. 153), the pieces are raised to the trail while moving back, brought to the order on halting, then to the right shoulder. The order is resumed upon halting.

Par. 167 (Plate 24). The left shoulder should be better covered by the piece.

Par. 179. The captain at company drill gives no commands for dressing as a part of any movement, but may at any time give commands for dressing just as for any other distinct movement.

Par. 182. Column of sections in close order is not provided for in the text. The section is not a subdivision for movement in close order.

Par. 184 gives the post of the captain after the company is formed. His post while the company is being formed is not prescribed.

Par. 186. The object of this paragraph is to determine the proper place of each man in the company, in double rank formation; thereafter, whenever the company forms, the men fall in in double rank, each in the four to which assigned. Application of Par. 186 at every formation of the company should not be necessary. The difference between the formation under this paragraph and under

paragraph 119 is in the omission of the command *front* after the commands 1. *In two ranks form Company*, 2. **MARCH**. In the School of the Company, the men are not required to raise the left arm to get their proper intervals, while in Par. 119 they are required to raise the left arm, and keep it raised until the command *front* (see interpretation of Par. 189). The second and third sergeants fall in on the right and left of the single rank, assist in the formation of the double rank, the second sergeant keeping his place on the right, and the third taking his place on the left of the front rank when the double rank is formed. The tallest corporal is the seventh man from the head of the column after the single rank has faced to the right, the other corporals are placed according to height; the next tallest, the eighth man in rear of the tallest; the next, the eighth man in rear of him, and so on. If there are more corporals than necessary for this formation, they are assigned to positions as directed by the captain.

Par. 186 and 187. The first sergeant sees that the entire company is properly formed before reporting to the captain; the file closers assist in placing the men where they belong. (See Par. 248). The captain draws sword, usually, after receiving the report of the 1st sergeant. The left hand is placed above the hip in dressing, and dropped at the command "front" in the School of the Soldier only. (See interpretation of Par. 189).

Par. 187. The habitual formation of the company should be as prescribed in Par. 187. See also Par. 186, particularly the last clause. The position of the 1st sergeant's piece while calling the roll is not prescribed except in general terms in the last clause of Par. 193, but this is not understood to mean that he is to hold his piece at the right shoulder if he has to refer to a list of absentees, a written roll, or has details to publish; he would habitually have papers of the kind named, and for convenience would hold his piece at the order. He

should, however, hold his piece in one of these positions—the right shoulder or the order. No separate formation of squads is contemplated, but each corporal sees that the men of his squad take their proper places. In all formations under arms, the men fall in at the order with bayonets unfixed, and this applies as well to all details, detachments, etc., for which other special provision is not made. The 1st sergeant simply reports the result of the roll call, (so many) sergeants, etc., absent, or that all are present, the Drill Regulations do not prescribe what words he shall use.

If there are more corporals than there are squads, the captain should assign them to positions where he most needs them. It is left to the judgment of the captain what position he shall take while the company is being formed; his duties involve attention to small details and he goes where he can best attend to them.

Par. 187 and 194. It is left for the captain to determine who should command "open chamber." (Par. 46).

Par. 188. When the fours are so broken up that Par. 187 does not apply, the company is formed as prescribed in Par. 188, which names the duties of the 1st sergeant in the order in which they are to be performed.

Par. 189. Par. 122 prescribes what applies in the School of the Soldier, Par. 189, what applies in the School of the Company, and, like other movements of the company, applies to the company in battalion as well as to the company alone. The interpretation of Par. 189 given by the President of the Tactical Board is to the effect that the left arm should not be raised, except in the School of the Soldier; but that the captain of a company may require the men to raise their left arms whenever necessary to correct their intervals in company or battalion drill, just as he may require individuals to look toward the guide to correct their alignment. In such cases each man should drop his left hand as soon as the man next on his left has his interval.

This interpretation is accepted as reversing those heretofore given of this paragraph and of Pars. 186, 187, 190, 208, 210, 221, etc., published in the *Army and Navy Journal*, so far as they relate to raising the arm in alignments. Guides are expected to move promptly to their posts at all times; no rule as to their moving in double time is given. Under Par. 232 (Plate 39) the 2d sergeant would move in quick time, the 5th sergeant in double time, and under Par. 288 (b) guides move out at a run.

Par. 190. In opening ranks, the captain goes wherever his presence is necessary until after he commands *front*. Lieutenants move by the shortest lines to their posts. The lieutenants carry sword until they reach their positions in front of the company. During the alignment the left hand is *not* held up at the hip. The definition of pace is given to cover just such cases as this—wherever used in the text as a measure it means thirty inches. (See definition of pace, pages 5 and 6.)

Par. 192. Company right. The movement terminates at the halt, exactly as it would if the command *halt* were given. The command "company" should not precede "lie down" or "kneel." An invariable rule cannot be given for the position to be taken by the officers and file closers when the men kneel or lie down; they should take such position as is best suited to the performance of their duties. The company marching in column of platoons is halted by the commands, 1. *Company*, 2. *HALT*. The company marching in line, pieces at the port, *company right* is executed as prescribed for the squad, Par. 140. Each man halts with his piece at the port and dresses to the right. The guide at the pivot halts or stands fast, and resumes his place at the command "*front*." The front rank man next to the guide is the pivot.

Pars. 193, 265 and 733. File-closers execute charge bayonet as prescribed in Par. 67.

Par. 193 prescribes the manual for guides and enlisted

men in the line of file-closers, and this applies to 1. *Port*. 2. *ARMS*, 3. *DISMISSED*. The 1st sergeant being at a carry when he salutes, remains at a carry while dismissing the company. The file-closers should execute charge bayonet on drill or parade unless specially excused. Guides remain in line and take part in firings. The 1st sergeant's bayonet should be fixed whenever the men have theirs fixed. Marching in line, pieces at carry arms, the guide remains at a carry when he halts. Guides carry their pieces as the men do.

Par. 194. The 1st sergeant dismissing the company is not given a precise position; he goes far enough to the front and toward the centre to see that his commands are properly executed. (See also Par. 6, last clause).

Par. 196. The file closers simply maintain their relative positions, without regard to placing themselves in line with fours or opposite certain intervals.

Pars. 196 and 199. The forward march is taken up on completion of the wheel by fours; the command "*Fours right*" is a preparatory command for marching in quick time in the sense used in Par. 112 (1st).

Par. 197. The Captain starts for his new position at the command "*March*."

Par. 198. The men, without command, align themselves on the marching flank, without turning the head more than necessary, and without raising the arm.

Par. 201. When the battalion is assembled in column of fours, each company is placed by its captain, in the most direct and convenient manner, in its place in the column. No guides are posted.

Par. 202. "*Fours right, column left*," would not be an incorrect movement. "*Right forward, fours right*," answers the purpose better.

Par. 206. The guides remain on the side opposite the file closers. (See Par. 197, seventh line.)

Par. 207. The whole rear rank closes during the wheel. In forming line to the right or left, if the pivots mark time accurately in place, and the command "Halt" is given as the four unite in line, no dressing is needed, and the command "Front" is not prescribed. The captain aligns his company whenever he considers it necessary, as prescribed in Pars. 189 and 123-126.

Pars. 207 and 211. While the fours are wheeling, the only spaces through which the file closers can conveniently pass will be between the rear rank of one four and the front rank of the succeeding four. In Par. 210 all the spaces, when the oblique commences, are alike. In all cases, the file closers, in changing flank, pass through the most convenient spaces.

Par. 208. Par. 118 applies to this movement.

Par. 210. The rear rank closes to facing distance before halting.

Par. 212. The expression, "a few paces," used in this paragraph, means a distance so short that wheeling about by fours twice would be inconvenient. The usual purpose of using "to the rear" is to place the company a short distance in rear of its original position. If the captain uses it for purposes of instruction, the size of the drill ground is all that limits him.

Par. 213. Such movements as may be necessary while passing an obstacle cannot be considered as prohibited by the final paragraph of the order of Oct. 3, 1891, adopting the Drill Regulations.

Par. 214. Note the uses of the movement stated at the beginning of the paragraph. While a column of fours might be halted at the entrance to a defile, it would not be done as a rule; but if it were, column of twos from fours at a halt would be, under Par. 4, allowable.

Par. 219. Column of fours from column of files at a halt would be executed only in exceptional cases, but it involves marching in quick time; hence under the

rule, Par. 112 (1st), pieces should be brought to the right shoulder. The pieces, if at the right shoulder, left shoulder, or trail, should, under Par. 112 (4th), be brought to the order on halting; if held in any other position during the movement, as at the carry, they should not be brought to the order on halting. Par. 112 (5th) does not apply to the movement; the movement is not named in Par. 112 (5th), and this rule is not mentioned in Par. 219. The rear rank men of the second, third and fourth files halt at forty-four inches from where their front rank men halt. In each rear four, the second, third and fourth files commence the oblique when their first file halts. "The other fours successively form as explained for the first."

Par. 220. Chiefs of platoons should repeat such commands as *forward*, *fours right*, *column right*, *halt*, etc. The command *march* in Pars. 234, 235 and 236 is a command to be immediately executed by a platoon, and is therefore repeated by its chief.

Par. 221. At the command *platoons right, march*, the right file of each platoon halts, the front rank man faces to the right, etc. (See Par. 140, third and fourth lines.) The first platoon begins to turn at the command *march*, given by the chief of platoon, which he should give immediately after the captain. The fifth sergeant in "platoons right" or fourth sergeant in "platoons left," from line in original formation, places himself by the side of the man on the pivot as soon as practicable, without waiting for the command *front*.

Par. 222. Forming front, or on right or left into line of platoons in columns of fours, guides take their places as soon as their platoons are disengaged.

Par. 223. Captain in column of platoons is always three paces from flank of column, on the side of the guide, in line with front rank of leading platoon.

Par. 225. The guide faces to the right and moves off at short step No. 1 of the right four of second platoon

faces to the right; the fifth sergeant gains the trace while marching.

Par. 232. The guide, marking the line at the centre of the company, passes around the flank to his post, as indicated for the fifth sergeant in Plate 39.

Par. 233. Applies to the simultaneous movement of the platoons in company drill, Par. 141 to the squad. It should be remembered that the platoons remain as separate platoons until the company is formed in line, and in each platoon the men dress toward the pivot. During the movement there is one guide of each platoon, marching at short step, on the line; it is essential that one should dress and regulate his interval on the other, and the captain's command for the guide should be given as indicated in the text, which is correct. See in this connection Pars. 237 and 310 (last four lines). With considerable inequality in the size of platoons, the guide should be announced on the side toward which line is to be formed, and the company marched a short distance in order that the guides may cover, or the guides should be caused to cover and the platoons be dressed at a halt.

The division into platoons should fall between fours; and to equalize the platoons in a small company, the usual method is to put enough men in the front rank to form the required number of fours, and form the rear rank as explained in Par. 186. The precise movements of the guides are not prescribed further than in Par. 222, but the guides at the centre of the company should drop to the rear into the line of file-closers as their platoons are about to unite in line.

Par. 234. The chief of the first platoon repeats the command *March* (Par. 220), and when his guide has advanced platoon distance in the new direction, commands *Platoon, halt*. The chief of the second platoon, in addition to the commands prescribed for him, commands *Platoon, halt*, so as to halt his platoon on the line.

Par. 243. Each platoon executes what is prescribed in Pars. 210 and 189 for the company, each chief of platoon giving the commands for his platoon.

Par. 250. In battalion drill, pieces are brought to the shoulder from the order when the captain gives a preparatory command for marching.

Par. 252. The position of the battalion adjutant would ordinarily be filled by detailing a lieutenant from one of the companies in the battalion, without regard to his rank, and without affecting the rank of the officer so detailed. There is nothing in the Drill Regulations on the subject. Par. 257 prescribes the positions and movements of the adjutant and sergeant-major of the battalion, from the sounding of adjutant's call to the posting of guides prolonging the line, inclusive, and Par. 260, their positions and movements to the completion of the formation. Par. 255 prescribes their posts in line, taken at the times prescribed in Par. 260. The positions of battalion adjutant and sergeant-major are all prescribed in the School of the Battalion, just as those of company officers are prescribed in the School of the Company, whatever be the number of battalions considered; each battalion being always regarded as a complete unit, having one adjutant and one sergeant-major. The positions of battalion-adjutant and sergeant-major cannot be assumed from those given the adjutant and sergeant-major of the regiment.

Par. 258. The captains designate their companies by letter in Par. 267, and again in the ceremony of parade, Par. 733; also whenever such a caution is necessary during battalion drill. The illustrations, "Co. 'A'" in Par. 253, is intended to show what is meant by "the letter designation," but not whether the captain in using it shall say "Co. 'A'" or "'A' company." The numbers in the table indicate the rank of the captains; in the four-company battalion, the first captain's company is on the right, the second captain's on the left,

the third next to the first. The numerical designation of a company, either in line or column means first, second, etc., from the right in line or the head in column, without regard to the rank of its captain. Close column is not formed on an interior company, and the leading or designated company forms the head of the close column.

Par. 254. The color guard is with the original right centre company, unless otherwise directed by the major or his superior. If assigned to the first battalion of a two battalion regiment, without express orders as to its position, the color in the original formation is with the second company and on its left. Tenth, eleventh and twelfth lines give post of color bearer in column of fours; he is never in the line of file closers.

Par. 257. The time when each company should start from its parade grounds depends upon the distance it has to march to its place in line, or upon orders of the commanding officer. To form the line as soon as possible after adjutant's call, the base company should be at very little more than 20 paces from its place in line when the adjutant and sergeant-major draw swords, and each of the other companies should be at about company distance and 20 paces from its place in line when the adjutant or sergeant-major starts from the point from which he established the guides for the preceding company. If each battalion has a parade ground of its own, that is the place for it to form, unless otherwise directed by the colonel. The sergeant-major reports to the adjutant whenever or wherever the adjutant directs; they may proceed together or separately to the point where the sergeant-major is first posted.

Pars. 257 and 258. The companies are usually marched out at the right shoulder and if the rules in Par. 112 are complied with, the men will be at the order when the captain commands *front*.

Par. 258. When captains take their posts, the com-

panies being in line, they bring their swords to the order if the men are at order arms. (See Pars. 491 and 492.)

Par. 260. Guides, at the command *guides posts*, trail arms, resume their posts and take the order. The about face is always to the right about, and guides do not always have to face about to resume their posts. The battalion must be brought to the carry before it can be brought to the order, from present.

Par. 261. The guides always face toward the point of rest.

Par. 265 gives the rules that generally apply to the manual of arms for the color guard; the exception thereto, for the ceremony of parade, is prescribed in Par. 733 (page 266).

Par. 267. Captains use the letter designation only. The captain of "A" company would, at the time prescribed, command 1. "*A*" company. 2, etc.

Pars. 267 and 268. In firings of battalion the major gives the command for loading. Note that if the major commands *load*, the battalion merely goes through the motion of loading without actually loading with any kind of cartridge. (See Par. 94.)

Par. 280. The major establishes the guides wherever he wishes to place the line.

Par. 282. The distance to be considered is that from the fixed pivot of the left four of one company, to the fixed pivot of the right four of the company next on the left; this distance is the same whether it is measured from the point between the heels of one pivot to the point between the heels of the other pivot, or from the left shoulder of one pivot to the left shoulder of the other. From left shoulder to left shoulder, passing from right to left, this distance will be as follows:

$$\underbrace{28'' \times 4}_{\text{to left guide.}} + \underbrace{90'' + 22'}_{\text{to right guide.}} + \underbrace{28'}_{\text{to pivot.}} = 252$$

When the wheel by fours is completed, the distance from pivot to pivot remains the same, whether measured from heel to heel, or back to back, and should be the same as above, *i. e.*, 252''. It is as follows:

$$\underbrace{44'' + 12''}_{\text{to back of rear rank.}} + \underbrace{44'' + 12''}_{\text{to back of rear guide.}} + \underbrace{72''}_{\text{to breast of leading guide.}} + \underbrace{12'' + 44'' + 12''}_{\text{to back of pivot.}} = 252''$$

Par. 285. The post of the color bearer in column of fours is given by referring to the position of the file closers; hence, if the file closers change, the color bearer must change also.

Par. 288 (*a* and *h*) and Par. 257 indicate that the adjutant or sergeant-major, in assuring the position of the guides in successive formations, does not remain at the point of rest, but places himself in rear of each pair of guides, and places the guides on the line, correcting their interval if necessary. In movements such as described in Pars. 289 and 290, the captain's command *Halt* determines the dressing exactly the same as if a separate command to dress were given. If the leading four does not halt accurately on the line, it is the Captain's duty to place it there as the base of the alignment. (See Pars. 208 and 210.) The same rule applies in Pars. 312 and 315, if the command *Halt* be given before completion of the turn. See Par. 141, twentieth to twenty-third line.

Pars. 289, 312 and 315. The command *Halt*, in each of these cases, is equivalent to *Halt, right* (or *left*) *dress*.

Par. 291. The wheeling about by fours in Par. 291 cannot be considered an alignment, and Par. 112 (5th) does not apply. If the major authorizes captains to bring their companies to trail arms before wheeling them about by fours, it will obviate the difficulty that arises from a strict application of Par. 112 (1st).

Par. 291-296. The companies execute "Front into line" successively, and in *double* time. The rear fours will sometimes arrive abreast of the leading four, and the company thus be marching in line before it arrives on the line established by the guides and is halted by the captain. In this case the company (being halted while marching in line) would not dress upon halting. The captain, therefore, under Par. 288 (*h*) should give the necessary commands for dressing his company toward the point of rest. *In general*, captains of companies, under Par. 288 (*h*) should always give the necessary commands for dressing toward the point of rest, in all successive formations, in which the *fours* or *files* of their companies *should* arrive successively upon the alignment for the battalion, but in which, for any reason, they *do* arrive upon the battalion alignment, and are halted simultaneously, *i. e.*, *in line*. As the "Front into line," in Pars. 291-296, is always executed in *double* time, and as prescribed in Par. 210, the captain of each company should command "*Guide right (or left)*," immediately after he commands "*March.*"

Par. 299. The position of the major in street parades would ordinarily be as prescribed for review. (See street parades at the end of this publication.)

Par. 301. Each Captain starts for the right of company at the command "*March.*" The Captain halts, as prescribed in this paragraph.

Par. 304. Guides carry their pieces as the men do; see Par. 193.

The rule stated in the last three lines of the paragraph is all that is prescribed as to the time when captains of the second and succeeding companies should give the commands for moving their companies forward. The second company should start when the captain of the first company is directly in front of the captain of the second.

Par. 310. To form line and halt. The rule in Par. 258 applies. The captains command "*front.*"

Par. 312. If guides are posted at company distance, which is the rule (Par. 288c), the turn will not be completed before arriving on the line, hence, when the captain commands *Halt*, the men on the line halt, the others halt on arriving on the line; all dress toward the pivot without command (Pars. 192 and 141, last six lines). If the turn should be completed before the company arrives on the line, which would not happen unless the guides are posted at greater than company distance, the company is halted and dressed by the commands of the captain.

Par. 323. To continue the march after a change of direction to the right or left, the battalion commander commands: 1. *Change direction to the right*, 2. *Double time*, 3. *March*, 4. *Guide right (left or centre)*.

Pars. 338, sixth clause, 413, last clause, and 414, last clause. The ployments of the designated battalions are in rear of the fourth company. In Par. 414 the battalion next in rear of the designated battalion ploys with its original left company in front when the other battalions ploy with their right companies in front and *vice versa*. See similar situation in Par. 435.

Par. 344. The same rule as for ployment of close column applies. See Par. 337, second clause, Guides are not posted for this movement.

Par. 346. The first company remains at the order.

Pars. 349 and 356. Captain's position is prescribed in Par. 223.

Par. 352. Each platoon moves up to the guides before halting. Each chief of platoon gives the command for his platoon, the captain giving the command *front*.

Par. 355. If the movement is executed from a halt, it is without gaining ground to the front; if from the march, ground is gained to the front.

Pars. 362, 363. Guides are not posted. According to Par. 224, the platoon column is halted by the same commands as a company in line; see also Pars. 180, 192. In

Par. 363, the company is halted and dressed; the captain must then give the commands, each chief of platoon giving the command "front" when his platoon is dressed. In Par. 362, dressing is not prescribed. Par. 366, Pars. 243, 210 and 189 furnish the explanations: each captain commands: 1. *Platoons*, 2. *Right* (or *left*), *front into line*, 3. *MARCH*, 4. *Company*, 5. *HALT*, and each chief of platoon gives the commands for his platoon.

Par. 367. The formation of street column should be by the most direct method; the distinction between "right in front" and "left in front" is not made use of in the Drill Regulations. In forming column of fours from street column, it is simply prescribed that each company takes its proper place in the column, and in doing this each captain gives whatever commands may be necessary.

An enquirer in the *Army and Navy Journal* says:—"Street column from column of fours, I have found some confusion and doubt among captains as to whether the second or third company should move to the right or left. some holding that one did part of the time and the other at other times. I finally adopted the rule that the second company should *always* move straight to the front and the third *always* oblique to the right or left. This removed all doubt and worked beautifully. I also think it conforms with the principle of tactics in executing a 'front into line,' while the rear fours or companies oblique or move to the right or left." According to the text, the second company should form in rear of the right of the first, and the third in rear of the left of the first, whether the first and fourth execute right or left front into line.

Par. 368. Drill Regulations cannot prescribe what shall constitute a regiment. The infantry regiment, to fully exemplify the Drill Regulations, should consist of three battalions; each battalion should consist of four companies, and should be commanded by a major. The regiment should be commanded by a colonel, and should have one lieut.-colonel and three majors. The regimental staff

and non-commissioned staff should be as heretofore. The battalion staff and non-commissioned staff should be constituted like that of the regiment, or have only one adjutant and one sergeant-major, according to the character of its service. For drill purposes alone the battalion should have an adjutant and a sergeant-major. In the Regular Service, as at present organized, the detail of officers and non-commissioned officers would have to be made to supply the places of two majors, three battalion adjutants and three sergeant-majors, thus depriving several companies of their complement. The assignment of companies of a regiment to battalions is left entirely to the discretion of the colonel; it is a matter of local regulation.

Par. 369. The number of mounted orderlies and how they should be armed are not prescribed; these are left to the discretion of the regimental commander, and should be determined by the character of the service required of them.

Colonel and staff, marching in column, band being present: For route marches, see Par. 369. In evolutions of the regiment, the colonel goes wherever his presence is necessary, his staff accompanying him. For street parades, the formation of the column is usually the same as for regimental review. (See Pars. 697-702 and Street Parades, at end of this publication). For position of colonel, see last clause, Par. 698; for Staff, Pars. 369 and 698.

Non-commissioned staff, regimental—For route marches, see Par. 369. Marching in review, six paces in rear of the band, in one line covering front of column, arranged in order of rank from right to left, sergeant-major on the right. At regimental parade, the staff, except the adjutant, are six paces in rear of the colonel. (See Pars. 680 and 681 for position of colonel and staff when the present is given). See Par. 369 for position of non-commissioned staff, regiment in line. Under the Drill Regulations, the band is considered a part of the regiment. (See definition of "head" p. 5). In column, the position of the colonel

“at the head” is in front of everything else belonging to the regiment. Position of battalion non-commissioned staff is the same in each battalion as if it were alone. (See Pars. 255 and 256). The regimental non-commissioned staff have no specific duties in the evolutions of the regiment; they should be excused, but this is at the discretion of the colonel.

Par. 370. As to the majors omitting to repeat the commands, the rule stated in the third, fourth, fifth and sixth lines of Par. 370 applies.

Par 371. What the Drill Regulations require is that the major shall put his battalion in its proper place by means prescribed in the School of the Battalion. The formation of the regiment is by battalions; each major gives all necessary commands for his own battalion, including *Guides posts*. In formation of regiment of two battalions in line of masses for review or parade, the adjutant of the regiment indicates the points of rest. Dress is always toward point of rest for each battalion, and the adjutant and sergeant-major of each battalion are on the side toward which the companies are dressed. When the regiment is about to be presented to the colonel, the majors do not repeat the commands of the adjutant. No invariable rule is laid down as to where the point of rest shall be; the adjutant of the regiment gives all necessary directions to the battalion adjutants. The adjutant of the regiment indicates to the adjutant of the base battalion the point of rest, which may be at the centre of the regiment, or on either flank. In forming line, the guides of each company come out and are established facing the point of rest; in forming line of masses, the guides of the leading company come out; in forming line of platoon columns, the guides do not come out; the guides of the leading companies are posted by the adjutant or sergeant-major of the battalion at the same time that he assures the other guides of the battalion, as prescribed in Par. 432. No duties are prescribed for the regimental sergeant-major in evolutions of

the regiment. The post of the sergeant-major is on the right of the non-commissioned staff; in line he is six paces to the left of the band; in column, six paces in rear of the rear rank of the band, or, if the original right flank is at the rear of the column, six paces in rear of the rear battalion. For all formations of the regiment, he takes his post in line as the last battalion is formed.

Par. 380. The position of the base company determines the direction toward which all the companies dress. The guides all face the "point of rest," *i. e.*, position of base company. If the alignment is on the centre, the second battalion is aligned on its centre, the right battalion dresses to the left, the left battalion to the right. See Pars. 257 and 280. The command "*On the centre (right or left)*" refers to the centre, right or left of the regiment. The colonel selects a base company—if a central company he commands "*On the centre,*" if a flank company he commands "*Right (or left).*" The guides of all the companies in the regiment face toward the base company.

Par 383. Wheeling from column of fours into line, no dressing should be necessary; the pivots should mark time accurately in place, and the command *Halt* should be given as the fours unite in line; or if the regiment is to move forward after wheeling into line, the colonel's command (such) *the base battalion*, followed by the major's *Guide centre*, fixes the guide. See Pars. 370 and 376.

Par. 395, Plate 74. The head of the third company of the third battalion, at the commencement of the movement, is at twice company distance from the line. In executing front into line, companies change direction at twice company distance from the line to approach perpendicularly, and each, when at company distance executes front into line. In Par. 395 the first and second companies execute front into line at less than company distance from the line, and to their movements Par. 209 applies.

Par. 414, Plate 77. The plate does not illustrate the movements of the first battalion in accordance with the

commands laid down. According to the plate, the first battalion is marched in column of fours and ployed in close column in an oblique direction. (see Par. 339, last clause, and Par. 340.)

Par. 422. The battalion in the second line may be placed wherever the colonel directs, but, in the absence of special directions from the colonel, is placed as shown in the plate.

Par. 426. *Column right* is correct. The change of direction of the second battalion is considerably greater than 45 degrees.

Par. 436. The leading company has to wheel by fours into line, at the major's command *march*, and this places the flank of the company at twenty-four paces from the close column of the preceding battalion.

Par. 487. Applied to the infantry sword having three rings on the scabbard, two for the slings on the back of the scabbard, and one for the purpose of hooking up the scabbard. To hook up the scabbard, raise the scabbard from its position after drawing or returning sword, without turning it, supporting it at the upper band, holding the ring with the thumb and forefinger of the left hand, the thumb through the ring; pass the ring over the hook and drop the left hand. When thus hooked up the guard of the hilt is to the front.

Par. 493 applies only to manual of the sword—the position of the feet, etc., are as prescribed in Pars. 24 and 60.

Par. 499 prescribes but one color guard for a regiment, and A. R. 1851, 1889, prescribes one national and one regimental color for each regiment of infantry. Where colors are authorized for particular battalions, the commanding officer selects the color bearers and guard for his battalion as the colonel does under Par. 499 for his regiment. The regimental color bearer is on the left of the national color bearer except when in column of fours with the file closers on the left flank, in which case the national

color bearer covers No. 4, and the regimental color bearer is on his right. The color bearer, *i. e.*, the sergeant carrying the national color, conforms to the movements of the battalion (Pars. 254 and 499). The sergeant carrying the regimental colors conforms to the movements of the color bearer (Par. 499); both move by the most convenient and direct lines. In a regiment of two battalions, the color will not be at the centre of the regiment, but at the centre of the battalion with which posted.

Par. 502. The pieces are carried at will, keeping the muzzles elevated. This applies to all movements in extended order. In this connection see Pars. 245, 106 and 509.

Par. 506. The corporals give the signal at the command *march*.

Par. 512. The cadence of step, as the term is used in extended order, means rapidity of gait, and in cases where the whole squad moves together is regulated by the corporal.

Par. 513 prescribes the posts that the corporals take "in front of their squads in line at the preparatory command for forming line of squads" (Par. 559).

Par. 520. Although the deployment is *always* on No. 2 front rank, the assembly, increasing and diminishing intervals is on the "base or guide," which may be any man whom the corporal may have designated and before whom he has posted himself. (See Pars. 525, 631 and 532.)

Par. 522. The corporal, before giving the commands for deploying, cautions the men to kneel or lie down upon halting. The precise words of the "cautionary command" are not given.

Par. 523. In the deployment as skirmishers, each man moves to his position at a rate of speed depending upon the distance he has to go to reach his place, the intention being that he shall get there with the least practicable delay, without command, other than cautions from the

corporal when necessary to correct errors. In the formations of line of squads (Par. 561 and 562), the same principles apply to the use of double time, as in corresponding movements in close order (Par. 208 and 210). The assembly is executed as prescribed in Par. 532. Double time is taken if the corporal continues to advance or may be taken at command, or caution to individuals, and in Par. 566 the same principle applies, the corporals regulating the rate of movement of their squads.

Par. 524. When the squad is by itself, the corporal's post is in rear as shown in Plate 92 (see Par. 520). In the company, platoon or section, when in line of squads, his post is in rear of his squad. Except in the case of a single squad the corporal's place is in the line of skirmishers, when his squad is deployed as skirmishers.

Par. 525. The men look toward the guide and each halts or moves to the front when he has his interval, without further command.

Par. 528. Changing direction when the line of skirmishers is marching by the flank is not a prescribed movement, but if occasion demands its use, there seems to be no reason why the instructor should not use it the same as in close order, on the principle that the formalities of drill should not interfere with the effective use of the men and their weapons.

Par. 531. Bayonets should be unfixed while deploying, and under Par. 576 while assembling or deploying.

Par. 532, third clause, explains what applies when the commands are *assemble, double time*.

Par. 534. See explanation under Par. 145.

Par. 542. Commands for firing in extended order must indicate the kind of firing, the objective and range, but, as indicated in this paragraph, commands *Halt* and *Load* are not necessary. At the preparatory command for firing the men halt, take the position indicated in the cautionary command (Par. 522), load, etc. Pieces are not habitually

carried loaded; Par. 542 explains when they are loaded. "Fire at will" is a preparatory command for firing, at which the pieces are loaded.

Par. 544. After the command *cease firing*, the pieces are loaded only by command.

Par. 559. The base squad will in almost all cases be either the right, left or centre squad; if more than three squads are in the platoon it is necessary to point out which is the centre squad. The rules stated in the 11th, 12th and 13th lines apply to the platoon in all formations from which deployments are made. In line of squads, the corporal is in rear of his squad. When deployed as skirmishers, the corporal belongs in the line of skirmishers on the left of his squad. The squad leader is responsible for the marching of his squad while moving into position, as in forming line of squads. (See Pars. 513, 515, 516, 559-561.)

Par. 560 prescribes the methods of forming line of squads from line; these are, to the front and by the flank. What commands does the corporal give for moving his men? One corporal says the proper command is *right oblique*, then *forward*. Another says give them "*Fours half right*, and then *fours half left*." Still another says, give *squad half right turn*, and then *half left turn*. Also in Par. 561, the explanation seems to be indefinite. ANS.—Corporal should usually make signal as prescribed on page 7, command "*squad half right*," or "*right half turn*," would be correct if that form of movement be preferred. "*Fours half right*" is not correct. Use the simplest method possible. (See Par. 511.) The corporal gives all signals and commands necessary for the movements of his squad, to carry out the orders of the chief of platoon. The command *double time* is given, and its use is explained. Last clause: The corporal places himself by the side of the leading man as in Par. 528, or indicates the direction by telling him where to go, according to convenience; with a squad not familiar with the drill, the former will usually

be necessary, and so also when not on a level drill ground. The corporal must choose his method according to circumstances. Plate 94 represents the formation of the platoon with one section (the firing line) in line of squads, the other section in support, when this formation is made from a halt. The position of the platoon in line is shown with the corporals of the first section in front of their squads in line, as they should be at the preparatory command for forming line of squads. The second section is represented as moved to the rear. The parts of the plate representing the men individually show the new formation; the other parts the original formation. For position of squads in firing line, see last three lines Par. 560; for the section in support, see twenty-fourth and following lines of Par. 559. The interval between squads is stated as *about* fifteen paces, in preference to stating exactly what that interval should be to give the exact interval of two paces between skirmishers; the accurate interval is $18\frac{1}{2}$ paces.

Par. 561. At the preparatory command the corporals, in rear of the first command *Right* or *Left oblique*, and after the command *March*, place themselves in front of their squads, each as soon as his squad has cleared the column.

Pars. 561 and 562. These movements being formation of line of squads from column of fours, the corporal would not take post in front of his squad until after the squad next preceding has cleared the column; at the commencement of the movement, the corporals march their squads as prescribed in Par. 516, and each, as soon as the preceding squad has cleared the column, takes his post in front, if he can from that position better supervise the movements of his squad. Par. 516 allows the corporal to go wherever his presence is necessary while marching his squad to its position, and in performing this duty he gives all necessary signals and commands.

Par. 562. The corporal of the leading squad signals *change direction to the right* or commands *right turn*. MARCH.

Par 563. Squads that have their interval should deploy without waiting till they arrive on the line of the base squad, and so with each squad when it gains its interval. Squads should gain their intervals only a little before or at about the time of arriving on the line, unless the character of the ground or the purpose of the movement causes considerable deviation from a direct course.

Par. 566 applies to the assembly of the platoon, whether in line of sections, squads or skirmishers. The assembly of the platoon may be at a halt or marching. In the assembly from line of skirmishers, line of squads is *not* first formed. The skirmishers close in from both flanks and form company, on the corporal of the base squad, or on any other skirmisher in whose front the company commander places himself. The squad leaders give commands or signals for the movement of their squads when the platoon assembles, but their duties in this movement are quite similar to those of file closers in close order; they give such cautions as are necessary to secure the execution of the movement by their squads. The squads do not assemble separately, but are conducted by the squad leaders to the place where the platoon assembles, unless the command be "Assemble by squads."

Par. 571. See Par. 528 for commands for chief of platoon; the squad leader gives the signal prescribed on page 7.

Par. 572. The corporals remain in the line of skirmishers at not more than a pace in rear of their places as skirmishers; they must keep their intervals like any other skirmishers. The corporals keep their places in line if deployed as skirmishers; in rear of their squads if in line of squads. The men halt and load without waiting for the commands of squad leaders or chiefs of sections; they kneel or lie down only when a command *kneel* or *lie down* has been given (Par. 522).

Par. 574. Each chief of section is six paces in rear of the centre of his section when the platoon is in line of

sections if the platoon is in the firing line, or six paces in front of his section if the platoon is in the support. (See Par. 559.) In the case of a single platoon, the whole platoon is considered as in the firing line when line of sections is formed. The section by itself assembles as explained for the platoon. The platoon may assemble by sections if necessary, although the assembly by sections is not a movement expressly provided for.

Par. 590. This firing is at the same objective as the one preceding; the range is different, and should be indicated, hence the command of the chief of sections would be, 1. *Fire by section*, 2. *At (so many) yards*, 3. *Section*, 4. *Ready*, 5. *Aim*, 6. *Fire*, 7. *Load*, and for the second and succeeding volleys fired at that halt—1. *Section*, 2. *Ready*, 3. *Aim*, 4. *Fire*, 5. *Load*, or 5. *Cease firing*. The commands in the 13th and 14th lines should be as here stated; those in the text are incorrect.

Par. 593. At the command *cease firing*, pieces remain empty, and *to the charge* and *the charge* are made with empty pieces (against an enemy supposed to have been subjected to the rapid fire from ground favorable for the assault).

Par. 621. In extended order the regimental and battalion sergeant-majors assist the adjutants in carrying out such orders as they receive from the colonel and majors respectively. They have no fixed posts.

Par. 657. " 'Ten minutes every hour.' What does this mean? A march of 50 minutes and a rest of ten, as is the usual custom, or a march of 60 minutes and then a rest of 10 minutes? Is the word 'in' not accidentally omitted before 'every?' " The two interpretations stated in the question give the limits intended in the rule. The rigid application of either independently of circumstances, is not intended.

Pars. 663 to 666. Bayonets are not fixed for ceremonies, unless specially directed by the commanding officer. For

ceremonies in full dress, knapsacks and blankets rolled are not usually part of the equipment: they become so properly only when specially directed by the commanding officer.

Par. 669. prescribes that the color passing in review shall be saluted by uncovering. Officers on duty under arms do not uncover, except to colors or standards.

Pars. 691 and 698, Marching in review at battalion or regimental review, the position of a battalion adjutant is on the *right* flank of the leading company.

Par. 692. * * "Non-commissioned officers in command of subdivisions salute and *return to the carry at the points prescribed for the major.*" This applies whether the non-commissioned officer is armed with a rifle or sword.

Par. 698. The formation for review is considered the most appropriate for street parades. (See Street Parades at the end of this publication.) This puts the regimental adjutant in the position prescribed by Par. 698. The colonel is at his post in front of the centre when he commands *pass in review, forward*, etc., his staff as prescribed in Pars. 369, 698 and 681. When the colonel receives the regiment, his staff, except the adjutant, are arranged in line, the centre six paces in rear of the colonel (see Par. 369), facing in the same direction as the colonel—*i. e.*, toward the regiment. When the present is made to the reviewing officer, the staff, the adjutant on the right, are six paces in rear of the colonel facing to the front, the colonel facing to the front except while giving commands (see Par. 681). Regimental staff at review.—The colonel takes post facing to the front (Par. 698), the staff officers, the adjutant on the right, ride six paces in rear of the colonel. The movements of the staff at review are prescribed in Regimental Review, Pars. 698-702, and in General Rules for Reviews, Pars. 673, 677, 680 and 681. A guard or regiment should march in review with bayonets unfixed unless the commanding officer directs

otherwise; this is entirely within his discretion. (See Par. 187, 1st clause.)

Pars. 698, 735 and 736. Each company forms on its own parade ground as prescribed in Par. 187 or 188; each battalion as in Pars. 257-261; then each battalion is marched to its place in line in the formation as directed by the colonel.

Par. 700. Each battalion is marched off by itself to its own parade and dismissed, unless otherwise ordered by the colonel.

Par. 701. The commands *Platoons right, march*, form the regiment in column of companies at less than full distance, with the original left platoon on the right of each company. The regiment, under this paragraph, passes in review in column of companies. In the platoon column, the distance is equal to the front of the rear platoon. (See Pars. 226 and 354).

Pars. 703 and 707. In brigade review, the salute is rendered when the reviewing officer has approached within thirty paces of the brigade commander, and the same applies in Par. 707 when the reviewing officer approaches from either the left or front; but if he approaches from the right, as in all except the first brigade, the salute is rendered when he arrives at the right of the brigade. The salute itself is always the same.

Par. 705. While the column is being formed and commencing its march in review the colonel moves from his position in line to his position in column, superintending the movement; he should arrive at his position in column, *i. e.* 24 paces in front of the band, when it has made its second change of direction; his staff follows in rear of him as prescribed in Pars. 369 and 698. Formations for street parades are usually the same as for marching in review. (See Street Parades at the end of this publication.)

Par. 712 directs that the first sergeant shall inspect the dress and general appearance of his detail; this does not

call for inspection of arms as in Par. 97, which is made by the officer of the guard or the adjutant. The regimental sergeant-major should form the guard at guard-mounting if the battalions of the regiment are serving together, unless the commanding officer directs otherwise.

Par. 713. At guard mounting an adjutant is not mounted. The posting of adjutant and sergeant-major at guard-mounting are not treated of as part of the ceremony other than that they take the posts prescribed. Whatever precedes their taking these posts must be according to circumstances. The paragraph indicates that the sergeant-major reports to the adjutant before taking his post, but does not prescribe that he does this after the adjutant takes his post. The simplest and most direct method that circumstances allow satisfies the requirements of the Drill Regulations. Details are marched out according to the principles prescribed in the School of the Soldier, or when large enough, by using fours according to convenience; there is no further restriction. In determining the number of men for guard no deduction is made for men who have marched on or off.

Par. 714. The position of the sergeant-major when he causes the guard to count fours is not prescribed.

Par. 715. The distance from the adjutant at which the non-commissioned officers of the guard should halt, there being no officer of the guard, is three paces.

Pars. 715 and 719. Assuming that there is a supernumerary officer of the guard, he takes position in rear of the first platoon at command *close ranks*. The guard has its complement when it has one officer; the "supernumerary" officer is one more than the complement, and is detailed, it may be, for purposes of instruction.

Pars. 715 and 733. Officers and non-commissioned officers place themselves just far enough apart to allow for a free movement of the arms, precisely as they have done in similar cases for years. Supernumeraries fix bayonet and open boxes at the command *inspection arms*;

no exception is made in their case. It is not the custom to inspect the first sergeants at guard mounting, but if so directed by the commanding officer, the first sergeant, being one of the men to be inspected, should fix bayonet and open box.

Par. 718 and 719. The officer or non-commissioned officer commanding the guard is three paces from the right flank of the column, abreast of the leading platoon, when the guard passes in review in columns of platoons. (See Par. 223.)

Par. 719 (last four lines) gives required information as to when and where the commander of a guard consisting of two platoons and having a supernumerary officer, takes post previous to and during the passage in review.

Par. 721. It is not prescribed that line should be formed before forming column of fours; the most direct method is preferred.

Par. 722. The guard marching in review, the position of the commander of the guard is on the *right* flank of the column, abreast of the leading platoon.

Par. 725 is a modification of Par. 720, hence, it is not a fair inference that the guard is marched to its post at a present.

Par. 727 refers only to ceremony described in Par. 726.

Par. 732 The Guard Manual referred to in Par. 732 is, at present, Kennon's, and will remain so until the one now being prepared is adopted by the War Department.

Par. 733, page 265. The adjutant, when he returns to the line of captains, places himself where he can best verify their alignments. If mounted, he would place himself in prolongation of the line of captains; if dismounted, the position is still well chosen, as the second officer in the line has then two points on which to align himself. (See Pars. 193 and 718 above.)

Par. 735 and 736. See explanation under Par. 628.

Par. 736. Each battalion is formed in all particulars as prescribed in Pars. 257-261, except that before presenting the battalion, the adjutant receives the report of the first sergeants; he then reports, "Sir, the battalion is formed."

Par. 737. Under Par. 665, the adjutants should be mounted. At regimental parade, the adjutant of the centre battalion, when making his report to the regimental adjutant, is directly in rear of the major.

Par. 739. The battalion commander should have his battalion in column of companies at full distance when the inspecting officer first approaches the battalion to inspect it. No salute is prescribed.

Par. 742. The lieutenant's face toward the company, if in front, during the inspection of knapsacks, the same as during the inspection of arms, etc., or accompany the captain if so directed.

Par. 745. The men are supposed to be uncovered before the command *Attention* is given. If the first sergeant accompanies the company commander at inspection of quarters, his equipment should be as directed by the company commander. The first sergeant should enter the squad room in advance of the company commander and give the command *Attention*; if under arms, he does not uncover; if unarmed, he uncovers.

Par. 747. The captain salutes, then faces the company and commands *Inspection, arms*.

Par. 762. Mention is made of the completion of the services and lowering the coffin for the purpose of indicating when the escort should be brought to attention, but not for the purpose of indicating which shall precede.

Par. 769. The call *fours right* is the same as *by the right flank*, and *fours left* the same as *by the left flank*.

MISCELLANEOUS.

I. No such ceremony as "undress parade" is provided for. In case a formation for publication of orders were required the companies would be merely notified to close in upon a designated company; the formality of standing at parade rest during the sounding of retreat would not be necessary. At the retreat roll call, as at reveille, upon reporting the result of the roll call, the company should be ordered to be dismissed instead of standing at parade rest during the sounding of retreat. White gloves are not required to be worn either by officers or men unless they should be under arms. (See "Undress Parade," published in the *Army and Navy Journal*, February 6, 1892.)

II. The dress for the day is prescribed by the commanding officer of the post under A. R. 1829, 1889. White gloves are worn at many posts at retreat roll call and the men are also required to appear at that time with their shoes and buttons, etc., neatly polished.

III. In the Regular service first sergeants do not wear swords at drill.

IV. Where a member of the guard is relieved for sickness and a supernumerary is substituted, both men are entitled to credit for one tour of guard. The "old guard fatigue" is a matter of post regulation.

V. When two or more men are standing, with or without arms, and an officer passes, if the senior non-commissioned officer calls out "attention" and salutes, if the non-commissioned officer is, under any order or detail, in command of the party, he alone would salute, otherwise each man salutes.

STREET PARADES.

VI. The following is from "Official Memoranda of Decisions on Point of Tactics," A. G. O., Washington, November 9, 1885:

"Street parades are not prescribed in Tactics or Regu-

lations, and no rules are laid down for them, They are, however, established by custom.

“On account of the width of the ordinary streets, the position for the staff, described in Par. 368, page 154 (Infantry Tactics.—Upton), is impossible; and as the occasion is a ceremonial one, the position prescribed in Par. 459 is inapplicable.

“The opinion expressed by General Hancock is correct, and the staff, in this case, should march as in review—Par. 815, page 355. (Letter to Commanding General, Department of the East, August 2, 1884.)

Par. 369, Infantry Drill Regulations, corresponds to Pars. 368 and 459 (Upton), and Par. 698, Infantry Drill Regulations, to Par. 815 (Upton), referred to above.

ADDITIONAL INTERPRETATIONS.

The following interpretations have appeared in the *Army and Navy Journal* since the first edition of this Addenda was published:

Par. 22 requires that at the command Rest only the heel of one foot shall be kept in place—it does not require that the whole foot shall be kept in place.

Par. 24. In executing attention from parade rest the left hand quits the piece in front when the piece is in the position of order arms.

Par. 29. Right or left hand salute can be executed by the numbers.

Par. 36. When, for instruction, the command is given mark time, the men do not bring the pieces to trail arms unless the instructor first commands trail arms.

Par. 40. A subscriber asks whether it is proper to give backward march when company is marking time. See par. 40.

Par. 48. Last line indicates that any command for a movement not in the manual of arms has the effect of the command “without the numbers.” “Foot movements,” right dress and parade rest without arms are not in the manual of arms.

Par. 49. (2d) defines “balance.” Tossing the piece from one position to another in the manual, while not prescribed, is, to some extent, encouraged, but only so far as

to develop handiness. In drilling the manual of arms by "the numbers," right or left dress would break the numbers.

Par. 51. When the piece has been raised vertically it will be directly over and parallel to its position at the order.

Par. 52. In coming from a carry to order arms, the right hand regrasps the piece below the left.

Par. 57. "Port arms" is executed while marching. The company being at port arms, company front, to execute "Company Right or Left," the men dress without raising the arm. The piece is not brought to the order on halting. The men can dress at port arms as well as at any other position of the piece, but the usual position while dressing being the order, no special mention is made of dressing with the piece at the port.

Par. 58. Right shoulder from port is executed in two motions, and by the numbers. Right shoulder from port may be executed either with or without the numbers.

Par. 60. Parade rest, with arms, is part of the manual.

Par. 63. Carry arms from unfixed bayonets, two motions—may be executed by the numbers.

Par. 64. After unfixing bayonets from the port, the port cannot be resumed.

Par. 66. If bayonets are unfixing while marching, the piece should be returned to the position in which it was when the command unfix bayonet was given.

Par. 67. The men having made a half-face to the right, the direction of the muzzle is to the front at charge bayonet, and in the position of load. Rear rank executes charge bayonets in the same manner as the front, taking care not to strike front rank. Charge bayonet is pre-

scribed from carry or order only and is executed by rear rank without stepping off to the right.

Par. 77. The command load should be given as soon as the firing has ceased; the sight-leaves will not, therefore, be touched in executing cease firing, load, unless the instructor gives his command improperly.

Par. 82. At position of load or ready, the right thumb clasps the small of the stock. Being at "secure," "trail," "sling," or "left shoulder," it is not allowable to come to "order," "carry," or any other position by the numbers.

Par. 83. It is correct to give open chamber when the commander of company knows that the pieces are loaded.

Par. 84. Pieces being at a position of "Draw, cartridge," they should be brought to an "order," before executing any other exercise in the manual of arms. It is allowable to execute the order by the numbers.

Par. 85. This position is *prescribed* for close order, but need not be used in extended order, at the sacrifice of the efficiency of the skirmisher. When lying down in double rank the rear rank men load and draw cartridge unless otherwise directed by instructor.

Par. 89. See purpose of Recover Arms and apply Par. 113.

Par. 97. It is not prescribed as to whether you use the thumb or forefinger to open the chamber of the piece at Inspection Arms.

Par. 105. No. 3 should resume his place as soon as he has handed his piece to No. 2.

Par. 106. Fours right from line, executed in quick time, arms at order, pieces are brought to right shoulder, at preparatory command. If drilling by the numbers, the command "order arms," pieces being at left shoulder,

would be correct, the piece should be shifted in the most convenient manner without reducing to motions or cadence. The gun can be brought from a trail to right shoulder under the rule in Par. 106.

Par. 107. First clause applies to close order movements in which the men have to move only a short distance; the muzzle is carried to the front from six to twelve inches. Second clause applies to more extended movements and to extended order.

Par. 108. Left shoulder should not be executed by the numbers.

Par. 112. If a captain gives "forward" (without march) and for some reason gives "halt," the men come down from the right shoulder. "The execution of the order and halt commence at the same instant as the command of execution, the three motions of the order in cadence." no matter what command determines the halt, and without waiting for the command "front." In dressing, the trail is executed by each individual, but all are supposed to commence dressing at the same instant—this should cause simultaneous execution of the trail; each man executes the order as soon as he is in his place. If pieces are in any other position than right shoulder, left shoulder or trail. they are *not* brought to the order upon halting. At Dress Parade the first sergeants should bring their pieces to a carry in halting.

Par. 113. It rests with the instructor to decide when circumstances require. It is possible to come to a "carry" after "fire" under this Par. only. As a rule, if a wrong command is given, the men should stand fast. Par. 113 does not allow departures from prescribed methods except in the battle exercises and when circumstances require; circumstances do not, as a rule, require such departures at drill in close order. This is not intended to encourage the giving of "catch commands," but a "wrong

command" is regarded as a mistake of the instructor, which he should promptly correct.

Par. 119. It is necessary for men to fall in facing to the front, Pars. 119 and 186.

Par. 121. When in close order the line should halt and stand fast until the command to dress, which should be executed as prescribed in Pars 121 or 123 and 189. The men in this case execute "front" at command.

Par. 129. It is correct to employ the command and movement of this paragraph in the school of the company, both in line and in column. 1. Backward, 2. Guide centre, 3 March. although not expressly provided for in the School of the Battalion, can hardly be considered an improper command, on the principle that any body of troops may be drilled as a squad.

Par. 131. It is correct to employ the commands and movements of this paragraph in the school of the company. The left foot starts all motions from a halt, but the "side step to right" By the right flank, in School of the Soldier, is not executed from a halt.

Par. 136. In the oblique movements at column of fours, in right oblique, the guide should not cross over. Par. 136 means that the men dress toward the side toward which the oblique is made.

Par. 138. At the command "double time" the rear rank makes no movement backward, but allows the front rank to gain the proper distance. It is proper to execute "mark time" while marching in "drill time."

Par. 141. From a halt, pieces at the order, pieces are brought to the right shoulder at the command right (or left) turn, which is "the preparatory command for marching in quick time." See Par. 112 (1st). If at a halt pieces at the order, pieces are brought to the trail at the command

march in backward march. See Par. 112 (5th), third and fourth lines.

Par. 142. The firings, Pars. 142-150, are not considered part of the manual of arms in applying par. 48.

Par. 143. At the order kneeling, command fire lying down, the rear rank moves back without rising.

Par. 144. At the command "Fire by company" the front rank stands fast.

Pars. 147 and 148. At the command cease firing, the movements prescribed in Par. 147 are executed in the order there named; if the command load follows it should at once be executed, whether all that is prescribed in 147 has been executed or not, but this command load is supposed to be given immediately after the firing stops, and before the sight leaf is lowered. Chambers should be closed before lowering the sight leaf, and in lowering the sight leaf it is proper to look at the sight

Par. 149. The purpose of the paragraph is stated in the last clause. See also Par. 113.

Par. 150 prescribes the method of forming a relief—no exception is made on account of the small number of men.

Pars. 153-156. Strict application of Par. 112 requires that in each of these movements the pieces should be brought to the shoulder at the preparatory command if at the order. but to avoid this the men should be brought to trail arms before commencing the movement.

Par. 154. For the rear rank to arrive in their proper places so that there shall be uniformity and precision in the movement. Each moves by the most direct line.

Par. 170. Bayonet movements: In executing the "thrust" from the left low parry and head parry, the barrel should be down.

Par. 182. It is not an uncommon practice to drill a small company as a squad or a large squad as a company, and when a section is by itself it may be treated as one or the other, it is a matter of no consequence which, so far as manœuvring it in close order is concerned. No preparatory command precedes "Right dress."

Par. 187. The captain when receiving his company from the first sergeant should return his salute.

Par. 190. The left arms are not raised in either rank unless so directed by the captain.

Par. 192. In Company right turn the guide is the pivot, the sergeant marches by the right flank, and the man on his left obliques to his side.

Par. 193. If a company is executing the manual of arms at a company front, the right and left guides execute the manual unless specially excused, and if they are excused they remain at the order. If there is an odd number of men in the relief their places in line are as follows: With five men, Nos 1 and 3 are in the rear rank; Nos 2, 4 and 5 in the front rank, No. 3 covering No. 5. With seven men, Nos. 1, 3 and 5 in rear rank; Nos. 2, 4, 6 and 7 in front rank, No. 5 covering No. 7. For "guides in front making the line" see Pars. 221, 233 and 288. The guides of the company, in close order, execute the loadings and firings.

Par. 194. The first sergeant salutes in his place.

Par. 196. The terms "fixed" and "movable pivot" as used in drill regulations are applied only to the wheels of fours. It is not considered that there is any impropriety in using these terms applied to the turn and halt, and to the turn; only the instructor who does so will find that he more than doubles the number of explanations he will have to make.

Par. 198. With a single company, on the march, the place for the surgeon should be designated by the captain—usually six paces in rear of the column.

Par. 200. "Changing direction" is illustrated in Par. 200; it applies generally to a movement of a column without change of formation. Par. 207 illustrates a wheel by fours, not a change of direction. In Par. 208 the movement of each four is described.

Par. 206. The rear rank man at the pivot close up to his file leader. During the wheel no one but the pivot man closes up. He closes at the command March.

Par. 208. Executed in double time, the leading four moves in double time till the command Halt.

Par. 210. Marching in column of fours, arms at a carry, when the command is given, Right front into line, double time: at the command, double time, the whole company should execute right shoulder arms.

Par. 212. After a line has been marched to the rear by either of the commands in this Par. it can be marched immediately to the front again without halting; by the command—To the rear, March.

Par. 217. A column of fours, twos, or files, while marching cannot be marched to the right (or left) by the command, By the right (or left) flank, March; or to the rear by the command, To the rear, March. The case of a captain wishing to march his company through a narrow space seems to be covered by Par. 217. "Original front" means the front of the column when originally formed. Par. 217 applies only to the column of fours, or twos, or files formed from fours.

Par. 218. On forming column of fours from column of files, each man comes to the order upon halting.

Par. 219. After forming column of fours from column of files, the company is put in march by command, Forward, March, the same as from other halts.

Par. 221. The second sergeant in platoons right, or third sergeant in platoons left, places himself by the side of the pivot man of his platoon at the command front.

Par. 232. The man next to the guide does what is prescribed for the pivot in Par. 140; the guide simply halts or stands fast, facing in the original direction until the command "front," when he resumes his post.

Par. 235. Conforming to the principle illustrated in Par. 210, to execute this movement in double time from line marching in quick time, the second platoon should continue the march in quick time until disengaged, and should oblique in double time. The whole company should execute right shoulder arms at the captain's command, "right by platoons."

Par. 237. The platoon guide who is not the guide of the company preserves the interval necessary for his own platoon to form front into line; thus, if the guide is right, the interval should be what is required to form right front into line.

Par. 237 and 364. Changing direction in column of platoons marching by the flank is not a prescribed movement.

Par. 238. A company having formed left front into line at port arms and being halted, the men dress. In plate No. 43 the first lieutenant has been omitted in the column of fours. For position of first sergeant see last two lines of Par. 247.

Par. 240. The chief of the first platoon gives the command "halt."

Par. 245. In giving commands, oblique is usually pronounced oblique; lootenant is correct; route, whenever used meaning rout, is pronounced rowt. These are matters of custom, not orders.

Par. 250. If the captain repeats the major's command, the execution of manual and movement are determined by the major's commands, otherwise by the captain's.

Par. 252. The officer in charge of a battalion is in command of it; the colonel commands him and his battalion, but exercises his authority over the battalion through the battalion commander. It is not the custom, and is not considered necessary, when battalions of a regiment are serving together, for all the papers of each battalion to pass through the hands of the major before reaching the colonel, nor for each battalion commander to keep a separate set of books and records, as consolidated morning report, etc. The major is responsible for the instruction of the battalion, and this involves the responsibility for its discipline, but to what extent is largely at the discretion of the colonel.

Par. 253. In each company the tallest man is on the right.

Par. 254. Whenever the color has to move from one flank of the color company to the other, the color bearer and guard move together by the most convenient route.

Par. 255. The position for battalion staff in column is proscribed in Par. 255.

Par. 256. In line of columns, the interval from the band to the nearest subdivision depends upon the manner of forming the line of columns; thus, from original formation, band on the right, if line of columns is formed at the command Companies right forward, fours right, the interval will be 24 paces; if companies left forward, fours left, the interval will be 24 paces, plus front of first company, less one four; the band moves straight to the front in either case.

Par. 257. Guides posted in battalion drill face toward the point of rest; if the point of rest is at the centre of the

battalion (an interior company) the two guides first posted face toward each other; if the point of rest is on a flank, the guides all face toward that flank.

Par. 257. The colonel assigns the companies to battalions at his discretion, then in each battalion the senior captain's company is on the right, the second on the left, the third in the centre; thus, the first, second and third captains may be assigned to the junior major's battalion, although this will probably never happen; but if so assigned, the companies of the regiment will form in the following order from right to left: fourth, sixth, fifth (right or first battalion), first, third, second (left or second battalion). The sergeant-major posts the guides of each company as they successively arrive; he precedes the guides on the line, or arrives there at about the same time as the guides first out; he resumes his position as soon as the guides of the company last to arrive on the line are in position.

Par. 260. The adjutant, dismounted, uses the right, left, or about face, according to the direction in which he has to face, the right or left face, as prescribed in Par. 27; the about, as prescribed in Par. 486; the about face is always executed to the right.

Par. 267. At the command "Fire by companies," the battalion should not execute "load" unless that command is given.

Par. 277. See last three lines, and Par. 254, fifth and sixth lines; Color bearer places himself in line with the guides, whether they are in original front or rear rank.

Par. 282. The adjutant and sergeant-major take their positions at the command "March."

Par. 284. A battalion in line, the proper command for the major is: Fours right, column left.

Par. 290. The sergeant-major remains with the rear company (if with that wing at the commencement of the movement) and takes his post in line as soon as that company comes upon the line; or, if he were at the head of the column when the movement commenced, he posts the guides and then takes his position in line.

Par. 291. Left front into line faced to the rear, the sergeant-major does not halt in the rear of the line and wait until the fours have been wheeled about before taking his position.

Pars. 293-297. The movements embraced within Pars. 293-297 may be executed from a halt.

Par. 301. The sergeant-major starts for his new position as soon as the company nearest him commences the movement.

Par. 314, strictly interpreted, requires that the men come to a right shoulder at the command fours right or left about, but it is considered a better practice for each captain to bring his company to trail arms before wheeling about by fours.

Par. 332. Closing and extending intervals when marching in line of platoons in columns of fours are not prescribed movements.

Par. 335. Executed in double time from a halt, the captain of the first company does the same, as though the movement were executed in quick time.

Par. 339. Fours may be wheeled toward the file closers, away from the captain. Each captain halts when he has gained the required twelve paces, and remains there until his fours begin the wheel into line, and then places himself by the side of the guide to dress his company. The guide need not be changed before the movement; the fours may be wheeled toward the file closer.

Par. **344.** Change direction by the flank is prescribed for close column only.

Par. **351.** The distance between platoons of the same company does not change.

Par. **362.** Platoons should be dressed upon halting; by command if they have completed the turn, without command if they have not.

Par. **367.** According to Par. 5, street column may be formed in double time, the leading company halting as from quick time. If both commands are en route to their places, the movement of each is a route march, during which no honors should be paid by either, but as every movement connected with a street parade is to some extent economical and as each involves rules peculiar to itself, it is suggested that the orders of the commanding officer should in each case prescribe how such salutes shall be rendered, if at all. The following references are here added: A.R. 428, 429 and 430, 1889. Infantry Drill Regulations, pars. 726 and 728. If any salute is ordered, the line, halted, should be at a present when the colors of the other command pass, each commander should salute the colors of the other, and the commanders should salute each other, the marching command being at a carry before its commander salutes.

Par. **371.** The position of the battalion sergeant-majors in regimental formations is the same as in the school of the battalion. The adjutant in presenting the regiment to the colonel says, "Sir, the regiment is formed." Position of battalion staff is the same in each battalion when the regiment is formed as in a single battalion. Battalion staff and non-com. staff for purposes of drill alone should consist of adjutant and sergeant-major. In turning the regiment over to the colonel the adjutant should report "Sir, the regiment is formed." The position of the non-commissioned staff, the regiment being in column of companies, on parade is in rear of the band.

Pars. 491 and 492. The sergeant-major returns to his post in line at the command, "Close ranks, march." For position of sword, see Pars. 491 and 492. Swords are held at the carry while "changing position", the sword is brought to the carry at the instant of stepping off, and the order resumed at the instant of halting.

Pars. 508 and 509. Men march at ease in line of squads.

Par. 523. The term cadence as used in extended order means gait; thus, in the eighth line, "resuming the cadence of the guide" means that the guide is moving at a fast walk, the men take that gait when they arrive in proper position. Deployment as skirmishers when marching to the rear is not interdicted.

Par. 527. In the extended order drill, the formation being in line of squads, when a blank occurs in the rear rank, at the march to the rear, it should be filled by man in rear.

Par. 531. If the corporal directs the squad to rally in circle, all face from the centre. If the corporal directs the squad to rally in circle, his position is as one of the squad; on rallying, the position of the men is at will, or as the corporal directs, according to circumstances. When the squad is rallied without advancing, if it forms in line the corporal's position is three paces in rear of the centre; if it forms in circle or semi-circle, he should be at or near the centre of the circle.

Par. 532. On assembling, the position of the piece is at the order bayonets unfixed.

Par. 560. In line of squads, faced or marching to the rear, in case of one or more blanks occurring in rear rank, does the front rank man close up and occupy the blank space, or does he maintain his original position in the front rank? **ANS.**—No rule is prescribed that covers the case exactly, but the usual practice is to require men in rank

in rear of blank spaces to fill them. The corporals command or signal, "By the right or left flank."

Par. 564. Plate 97 shows deployment from the march.

Par. 565. The reference to Par. 525 in Par. 565 covers only last three lines of 525.

Par. 566. The Attack—First Lieutenant commands, First and Fourth Section Halt; now this would leave the first and fourth sections some distance apart; are they marched to the front with this interval between the first and fourth sections, or is the interval closed up, and if so, by what orders? ANS.—The interval may be preserved or not according to the orders of the captain. The interval may be closed by directing one section to close in upon the other, or by the commands Assemble, March.

Par. 570. The squad at the pivot executes the turn and halt, the others execute the half-turn and advance twice and halt when they arrive on the line of the pivot squad.

Par. 592. When both lieutenants are in the firing line, to fire a volley, the captain would command "Fire by Company," this applies whether the whole company is in the firing line or not.

Par. 665. Parades are prescribed for each arm of the Service separately, but not combined. Reviews of combined cavalry mounted and infantry should be in brigade formation. Adjutants of infantry battalions should habitually be mounted—see Par. 665.

Par. 669. The commander of a regiment or battalion does not return sword on taking his place on the right of the reviewing officer; he salutes the color with his sword. Officers passing down the line at review should salute the the colors by uncovering. The reviewing officer returns the salutes of the three battalion majors in the review of a regiment. The officer saluting turns his head as he be-

gins the salute, *i. e.*, six paces from the reviewing officer, and keeps his head turned to the right until six paces past the reviewing officer.

Par. 690. It is customary for the reviewing officer, at a battalion review to return the salute of the major by uncovering, but not authoritative.

Par. 698. At the command, "Companies right" the adjutant and sergeant major take their position on the right of the column at the command "March."

Par. 700. Do the company officers leave their battalions, and are at once dismissed, or march with their companies to their battalion parade grounds, and there turn their companies over to their first sergeants, or do they march their companies to company parades, and there dismiss them? Answer.—As directed by the commanding officer.

Par. 707. The colonel of a regiment, whether at division, brigade or regimental review, turns out of the column after he has saluted, and takes his place by the side of the reviewing officer, according to Par. 677.

Par. 712. The question whether the band leader should march with the band on to the parade ground for guard mounting or wait until they are stationed, is a matter for the post adjutant to settle.

Par. 715. The officer, commander of the guard, while waiting for the command "Inspect your guard, sir!" stands at carry. At guard mount when there is but one officer of the guard, the adjutant after assigning officers and non commissioned to places commands: 1. Non commissioned officers. 2. Posts. 3. March.

Par. 717. Although not prescribed, it is considered proper for the supernumerary officer to take his place on the left of the commander of the guard. The first sergeant usually marches out his detail just as a corporal marches his relief, placing himself a little to the left and rear; he

may march the detail in line, placing himself two paces in front, but this is unusual, and with small details awkward.

Par. 718. In guard mounting, the adjutant and commander of the guard do not salute when the adjutant directs the commander to inspect the guard.

Par. 733. The place at which the adjutant halts is usually at such a distance to the front that it is more convenient for him (if not mounted) to halt facing the major, and then make an about, face, and this is usually done. If the adjutant's distance is so short that his path in approaching the point is nearly parallel to the front of the battalion, he should halt, facing to the left, and then make a left, face. The position of the captain of company at open ranks at battalion parade is three paces in front of the centre of the company. Formation for battalion parade should be in line. The centre of a battalion is understood to be midway between the flanks; thus, in a three company battalion, it would be at the centre of the centre company. The major's post is in front of the centre as above defined.

Par. 737. At regimental parade when the officers disperse the sergeant major is dismissed. The regimental adjutant does not return salute of the battalion adjutants when they report at parade on going to the front and centre. At command "posts march," officers and non commissioned officers should march by the shortest route to and from posts.

Par. 739. At the command, "Prepare for inspection," the non commissioned staff move to take their position at the head by the shortest line.

Par. 740. The major waits until he has returned to the head of the column before giving the command "rest."

Par. 742. The inspection of a single company is made as in Par. 742. The bottom of the knapsack should be next

to the feet when knapsacks are unslung. Ranks are opened before knapsacks are unslung. that is, rear rank has moved back to a distance of 90 inches measured from breast of front rank to breast of rear rank; front rank step back 15 inches and faces about; in facing about each man turns on his right heel, and therefore, twice his depth must be deducted, assuming that all his depth is in front of his heels, hence 90 inches - (15 inches + 24 inches) = 51 inches, distance from breast to breast after unslinging knapsacks. Under par. 98 the distance is as follows: $16 + 6 = 22$ gives distance from back of front rank to breast of rear rank before stepping back, $22 + 45 = 67$ from back to breast after rear rank steps back, $67 - 15 = 52$ after front rank steps back, and $52 - 12 = 40$ after front rank faces about.

Par. 747. The captain returns sword as soon as inspected and accompanies the inspector (see Par. 742).

Par. 749 The major faces about towards his battalion while the inspector is passing down his column.

ARMY AND NAVY JOURNAL.

Publishes weekly official orders and other information of immediate interest as well as of historical value concerning the military services which can be found nowhere else, including a professional account of the movements of our own and foreign armies and navies and a description of the experiments and discoveries illustrative of military and naval science.

Heretofore on the adoption of new tactics, numerous questions as to their interpretation have arisen. Those relating to the interpretation of Casey's Tactics were answered through the Army and Navy Journal by General Casey, on whose staff the Editor of the Journal served during the Civil War. When Upton's Tactics were afterward adopted, questions concerning them were answered through the Journal by General Upton during his lifetime. Since his death such questions have, when necessary, been referred by the Editor of the Journal to the proper authorities for official determination. This practice will be continued by the Army and Navy Journal in the case of such questions concerning the interpretation of these Drill Regulations as appear to require official interpretation to settle disputes. The names of many of the most distinguished writers on professional subjects in this country and Europe, including some of the most distinguished officers of our own and other services, are included in the list of contributors to the Army and Navy Journal.

For sale by newsdealers, or can be ordered from

W. C. & F. P. CHURCH, NEW YORK.

Subscription price to clubs of ten and to individual officers and men in the service of the United States, three dollars a year. Regular subscription, six dollars.