

Folks,

Text-Book of Seamanship, 1891, is an updated age of sail textbook at the beginning of the true transition of warships from sail to steam power.

In this online version of the manual we have attempted to keep the flavor of the original layout while taking advantage of the Web's universal accessibility. Different browsers and fonts will cause the text to move, but the text will remain roughly where it is in the original manual. We have not attempted to correct any errors found in the original document. However, this text was captured by optical character recognition and then encoded for the Web which has added new errors we wish to correct.

Please report any typos, or particularly annoying layout issues to info@hnsa.org for correction.

Richard Pekelney
Webmaster

[Search HNSA.ORG](#)

TEXT-BOOK
OF
SEAMANSHIP.

THE EQUIPPING AND HANDLING
OF
VESSELS
UNDER SAIL OR STEAM.

FOR THE USE OF THE
UNITED STATES NAVAL ACADEMY.

BY
COMMODORE S. B. LUCE, U. S. NAVY.

REVISED AND ENLARGED BY
LIEUTENANT AARON WARD, U. S. NAVY.

WITH ILLUSTRATIONS DRAWN BY
LIEUTENANT S. SEABURY, U. S. NAVY.

New York:
VAN NOSTRAND COMPANY,
23 MURRAY STREET & 27 WARREN STREET.

1891.

**TEXT-BOOK
OF
SEAMANSHIP**

THE EQUIPPING AND HANDLING OF
VESSELS
UNDER SAIL OR STEAM.

FOR THE USE OF THE
UNITED STATES NAVAL ACADEMY.

BY
COMMODORE S. B. LUCE, U. S. NAVY.

REVISED AND ENLARGED BY
LIEUTENANT AARON WARD, U. S. NAVY.

WITH ILLUSTRATIONS DRAWN BY
LIEUTENANT S. SEABURY, U. S. NAVY.

New York:
VAN NOSTRAND COMPANY,
23 MURRAY STREET & 27 WARREN STREET.

-
1891.

Copyright, 1834, by D. Von Nostrand

SMITH & MCDUGAL,
ELECTROTYPERS

PREFACE TO THE REVISED EDITION.

THIS work, originally compiled in haste to meet the immediate wants of the Naval Academy, and revised at different periods under the pressure of other duties, has not merited the place it has so long occupied as

a text-book.

Of this the compiler has been fully conscious. Its deficiencies were so numerous and so obvious and the circumstances under which it was prepared so well known that apologies seemed altogether superfluous.

It was for long years supposed, moreover, that some more competent hand would have undertaken an entirely new work.

Finding this expectation not realized, Lieutenant Aaron Ward has kindly consented to undertake the task of revision. He has performed his work intelligently and well, leaving out what was obsolete, introducing much new material, rearranging the subjects, and bringing the text down to the present time.

He has been ably assisted by Lieutenant Samuel Seabury, who has contributed some four hundred new illustrations and revised the old ones.

S. B. LUCE,
Commodore, U. S. N.

TRAINING SQUADRON,
NEWPORT, R. I., Feb. 1883.

REVISER'S NOTE.

GRATEFUL acknowledgments are due to those whose contributions to the text have enhanced the value of this work.

Commander F. V. McNair has permitted the use of his pamphlet on Seamanship Drills.

The chapter on the Laws of Storms is taken principally from the lecture of Lieutenant-Commander Thomas Nelson, Vol. V, Proceedings U. S. Naval Institute.

Chapter XIX. is practically a reprint of Lieutenant D. Delehanty's pamphlet: "Cadet Midshipman's Manual."

Chapter XXXV. has been prepared from notes furnished by Lieutenant-Commander Z. L. Tanner, together with data from the lectures of Constructor R. H. White, R. N., and from the professional pamphlets of the German Admiralty on steamers and screw propulsion.

The suggestions made by Boatswain Robert Anderson, U. S. N., have been of special importance. Getting a lower yard on board, sending down a lower yard inside of rigging, rigging derricks, and carrying out anchors between two cutters in shoal water, are described from actual work performed under his direction.

To Commander Taylor, Lieutenants Berry, Nazro, and Holman, U. S. N., and to many other officers, sincere thanks are tendered for their assistance and suggestions in the revision of the proofs.

AARON WARD,
Lieutenant, U. S. N.

CONTENTS.

CHAPTER		PAGES
I.	-THE SHIP-DEFINITIONS	1-10
II.	-THE COMPASS-THE LEAD-THE LOG	11-20
III.	-ROPE	21-30
IV.	-KNOTTING AND SPLICING	31-62
V.	-BLOCKS	63-69
VI.	-TACKLES	70-79
VII.	-MASTING-THE RUDDER	80-95
VIII.	-STANDING RIGGING	96-109
IX.	-RIGGING SHIP	110-155
X.	-SAILS	156-172
XI.	-PURCHASING WEIGHTS	173-189
XII.	-STOWAGE	190-198
XIII.	-BOATS	199-229
XIV.	-GROUND TACKLE	230-260
XV.	-STEAM CAPSTANS	261-267
XVI.	-MOORING	268-278
XVII.	-CARRYING OUT ANCHORS	279-288
XVIII.	-ORGANIZATION	289-307
XIX.	-DUTIES OF MIDSHIPMEN	308-322

XX.	-PORT DRILLS AND EVOLUTIONS	323 -359
XXI.	-RULES OF THE ROAD	360 -379
XXII.	-GETTING UNDER WAY UNDER SAIL	380 -394
XXIII.	-MAKING AND TAKING IN SAIL	395 -411
XXIV.	-WORKING TO WINDWARD	412 -431
XXV.	-WIND BAFFLING	432 -439
XXVI.	-HEAVING TO	440 -448
XXVII.	-REEFING	449 -456
XXVIII.	-LAWS OF STORMS	457 -470
XXIX.	-IN A GALE	471 -481
XXX.	-PARTING RIGGING	482 -491

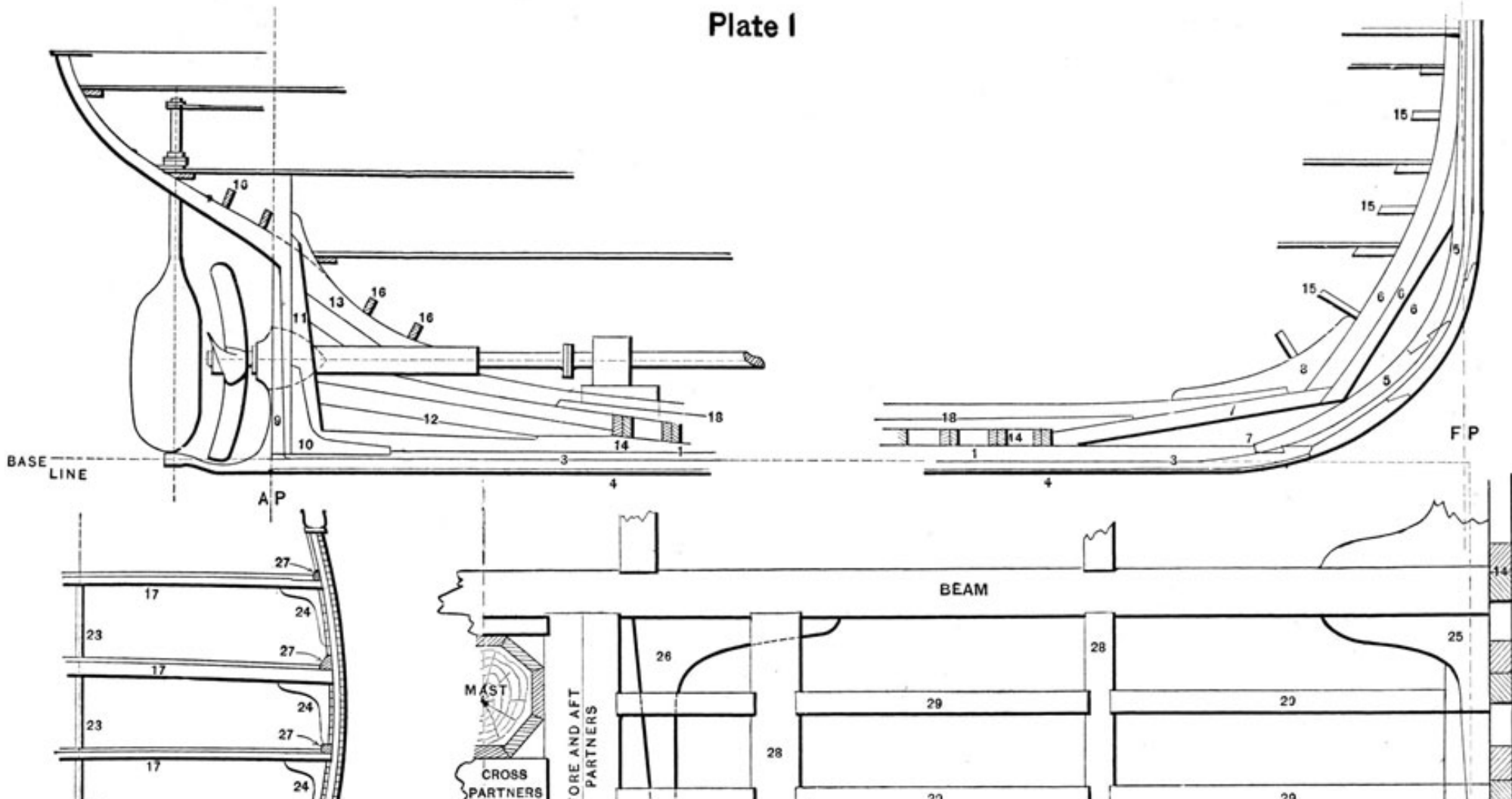
vi

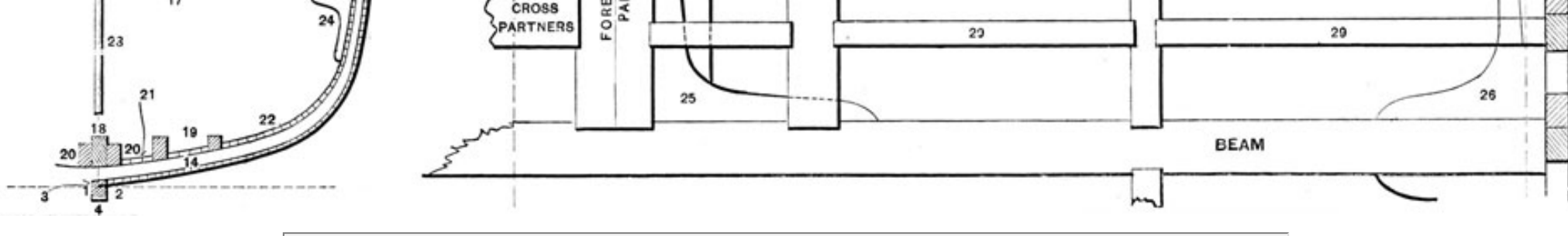
CHAPTER	PAGES
XXXI. -LOSING SPARS	492 -501
XXXII. -SHIFTING SAILS AND SPARS	502 -516
XXXIII. -COMING TO ANCHOR	517 -526
XXXIV. -HANDLING FORE-AND-AFTERS	527 -536
XXXV. -HANDLING VESSELS UNDER STEAM	537 -575
XXXVI. -GETTING ON SHORE-LEAKING	576 -587
XXXVII. -THE LIFE-SAVING SERVICE	588 -597

APPENDIX.

	PAGES
A. -ROPE-MAKING-TABLE OF DIMENSIONS OF ROPE	598 -603
B. -CUTTING AND FITTING BLOCK STRAPS	604 -605
C. -TURNING IN OLD-FASHIONED DEADEYES-RULES FOR SIZE OF SHROUDS	606 -609
D. -STAYING MASTS BY-USE OF BATTENS	609 -610
E. -TABLES OF FLAX AND COTTON CANVAS	610 -611

F. -MANAGEMENT OF OPEN BOATS IN SURF	611-613
G. -ROUTINE-PREPARING SHIP FOR SEA	614-618
H. -TARRING DOWN-SCRAPING SPARS-PAINTING SHIP	618-620
I. -IN A TIDEWAY UNDER SAIL	620-622
K. -TENDING SHIP AT SINGLE ANCHOR-FIRE BOOMS	622-626
L. -TURNING EXPERIMENT-METHODS OF DETERMINING TACTICAL DIAMETERS	627-644
M. -TANNER SOUNDING MACHINE	645-646
N. -SHIP PAPERS	646-647
O. -SERVICE BUGLE CALLS	648-659
INDEX	660-672





CHAPTER I.

THE SHIP.

GENERAL REMARKS ON THE HULL, SPARS, AND SAILS.-DEFINITIONS.

Wooden ships are usually built on stocks and launched on ways, which are inclined planes leading to the water's edge. Sometimes vessels are built in docks, which are artificial basins with level floors, shut off from outside waters by gates or by a single dam known as a caisson. These gates are water-tight and can be opened or closed; the dock is supplied with means for pumping out the water or letting it in.

The lowest fore and aft piece which forms the foundation of a ship is called the keel (Plate 1, No. 1). It is of live-oak, or elm, and made of several pieces, the joints of which are known as scarphs.

To receive the edge of the first row, or strake, of outside planking, called the garboard strake (2), the keel is scored throughout its length, the score being styled a rabbet (3).

To protect the main keel from injury in grounding there is fitted under it a false keel (4), bolted on after the bolts which secure the frames to the main keel are clinched.

The forward end of the ship is formed of the stem (5), usually of live-oak, and inclining forward from the keel. A rabbet, similar to the one scored in the keel, is cut into the sides of the stem and receives the forward ends of the outside planking, which are called the fore hood-ends.

The stem is backed and strengthened by the apron (6), placed abaft it, and by the deadwood (7).

Deadwood consists of timbers that fill the spaces where, owing to the shape of the vessel, the floor-timbers have to be discontinued.

Inside of the forward deadwood and the apron is the stemson (8), a large knee which joins the apron to the upper part of the deadwood.

The after-end of the ship is bounded by the stern-post (9), usually of live-oak, which stands perpendicular

to the keel or slightly inclined aft. It is fitted like the stem with a rabbet on each side to receive the after-ends of the outside planking, or after-hoods, and it is strengthened by the introduction of a stern-post knee (10), inner post (11), and the after-deadwood (12). Above the latter is the after-deadwood knee (13).

2

Screw vessels have generally two stern-posts; the after one, which carries the rudder, is called the rudder-post.

The joining of the stern-post to the keel is effected by tenons and bolts.

The frames (14) form the ribs of the ship. They stand mostly at right angles to the keel and each is formed of two parts joined together, each part being in itself made up of several pieces. The lowest portions of a square frame are called the floor-timbers; above these come the futtocks, then the long or short top-pieces. The starboard and port side of each frame form one continuous piece.

Where, owing to the form of the ship, the frames do not stand at right angles to the keel, they are called cant frames.

The following parts of the ship serve to secure the above-mentioned portions together and give the structure stiffness and strength; viz., the keelsons, breast-hooks (15) and stern-hooks (16), outer and inner planking, beams (17) and diagonal braces.

The main keelson (18) is a fore and aft timber which is laid directly over the keel on the floor-timbers and may extend beyond the latter and over the deadwood, forward and aft. The keelson is bolted through frames, keel, and deadwood. There are usually additional keelsons at each side of the main keelson, known as sister keelsons (20). There are also boiler or bilge keelsons to support the boilers (19). Bilge-keels are exterior keels bolted on to the bottom of the ship on either side of and parallel to the main keel, and at some distance from the latter, to prevent rolling in vessels of certain form.

To hold the two sides of the ship together in the forward and after ends, where the frames have no floor-timbers crossing the keel, owing to the form of the ship, there are worked in knee-shaped, horizontal timbers, either with a natural curve, or formed of two or more pieces backed by an iron or wooden knee. These curved supports, secured to either side of the ship, are termed breast-hooks (15) forward and stern-hooks (16) aft; when they support a deck they are called deck-hooks.

The outer planking of a ship is formed of a number of oak planks of varying thickness, but nearly parallel when placed in position over the frames.

To check marine growth on the bottom of vessels and the consequent decrease of speed, all wooden vessels of war are sheathed with copper from the keel to a point some distance above their line of

flotation, or "water-line."

Inner planking. This planking is not continuous, as in the case of outside planking, and in different parts of the ship is called by different names. It is known as the limber-strakes (21) nearest the keelson. These strakes extend along the bottom of the ship on either side of the

3

keelson. As the planking is carried up the side beyond the limber-strakes it is known as the ceiling (22); following it up higher we find projecting ledges, called shelf-pieces, or clamps, placed inside the frames to receive the deck-beams.

The deck-beams (17), extending from side to side of the ship, holding the sides together, form the support for the deck-planking. The beams are supported by posts or stanchions (23) in their centre, and by clamps at each end. They are joined to the sides of the ship by iron or wooden knees, known as hanging (24), lodging (25), lap (26), or dagger (corruption of diagonal) knees, from their positions and form.

The waterways (27) are timbers set in the side over the tops of the deck-beams and bolted to these and to the frames at the side.

Decks are of oak, teak, or yellow pine, and are spiked to each deck-beam over which they pass.

Vessels owe much of their strength to the use of diagonal trusses or braces, of metal, secured inside of the frame-timbers and forming a net-work which binds the frames firmly together.

To the above outline of the parts of the hull is appended a list of prominent interior fittings and of the terms used in describing them:-

Aft. At or near the stern of the ship.

After passage. Usually a space in the after orlop of frigates, being a passageway to the different store-rooms on that deck.

Air-port. Hole cut in ship's side to give light and air to berth-deck. Usually circular.

Amidships. In or near the middle of the ship.

Apron. A timber secured in rear of the stem to strengthen it at the joint of upper and lower stem-pieces.

Athwartships. In the direction of the ship's breadth.

Bag-room. Where clothing-bags of crew are stored. Usually forward on the berth-deck or leading off of fore-passage.

Ballast. Stone or iron placed in the hold to bring the ship down to her proper line of flotation and give stability.

Beams. Timbers that extend from side to side, supporting the decks.

Bee-blocks. Clamps bolted to the bowsprit through which reeve the fore-topmast stays.

Belaying-pin. A pin of wood or metal at the side of the vessel or on the masts, around which a rope is fastened or *belayed*.

Bends. The thickest outside planking, extending from a little below the waterline to the lower gun-deck ports.

Berth-deck. The sleeping and mess-deck of the crew and officers of a ship.

Bibbs. Pieces of timber on either side of the mast to which the trestle trees are secured.

Bilge. The flat part of a ship's body on each side of the keel.

Bilge-keels. Long pieces of wood or iron affixed to ship's bottom to lessen the rolling motion.

Bill-board. A ledge on the ship's bow to receive the fluke of the anchor

Binnacle. A box containing the ship's compass.

Bits. Large vertical timbers projecting above the deck to secure the ship's cable, also vertical posts to secure the main-tack, main-sheet, etc., according to location.

Boat-chocks. Blocks of wood shaped to receive the bottoms of boats, when hoisted in.

Bolsters. Rounded blocks of wood filling the angle between the trestle-tree and the mast, to prevent chafing of the rigging against the former.

Bolts. Pieces of iron or other metal used in fastening parts of the ship together.

Booby-hatch. A small hatchway, or the covering or *companion* of such an aperture.

Boom-iron. Iron rings secured to one yard or spar, to support another spar, which passes through the iron. Such are the studding-sail boom-irons on the lower and top-sail yards.

Bowsprit-bed. The part of the stem on which the bowsprit rests.

Bread-room. The store-rooms in which are kept the ship's allowance of hard-bread, etc. Usually situated in the after orlop.

Break of Forecastle. Where the rise of the forecastle towards the waste of the ship, ends. Commonly used to define the after side of a top-gallant forecastle.

Break of Poop. Where the rise of the poop towards the waist, ends. Commonly used in speaking of the forward end of the poop.

Breast-hooks. Knees, or an assemblage of timbers, set in the bows of ships and secured on either side to the timbers of the bow.

Bridle-ports. The ship's forward gun-ports. Through these ports are led the *bridles* of tow-lines or warps.

Bridge. A light structure extending across the ship above the spar-deck, to afford the officer of the deck or lookout a place for observation.

Bucklers. Shutters used in closing hawse-pipes (hawse-bucklers), or filling the circular opening of half-ports when there is no gun in the port (port- bucklers).

Bulk-heads. Partitions that divide off different parts of the ship.

Bulwarks. The sides of the ship above the upper deck.

Bumpkin. A projection of wood or iron from the bow or quarter, to give proper angle for the lead of the fore-tack or main-brace.

Cabin. The quarters of the commanding officer of a ship. On the gun-deck of a ship with flush spar-deck, or under the poop (*poop-cabin*) of a single-decked vessel or one having a poop in addition to a covered gun-deck. In the latter case the gun-deck cabin is usually occupied by a flag officer.

Cable-tier. Formerly platforms on which the ship's cables were coiled. At present understood to mean light platforms in the wings where spare rigging is stowed.

Cant-frames. Frames, forward and aft, which are not at right angles to the central fore and aft line of the vessel.

Cap. A joint fitted over the heads of masts to support the next higher mast, which passes through a hole in the cap.

Cap-shore. A stout upright which supports the forward edge of the lower cap.

Capstan. A barrel of wood or metal that revolves horizontally on a spindle; is used with capstan-bars or moved round by steam to raise heavy weights, weigh anchor, etc.

Carlings (28). Short timbers running fore and aft, connecting the beams.

Cat-head. An iron or wooden projection from the ship's bow to raise the anchor clear of the water.

Caulking. Filling the seams of a ship with oakum or cotton.

Cavil. A large wooden cleat used for belaying.

Ceiling. Portions of the inside planking of a ship.

Chains (see Channels). *Chain chests.* Lockers in the channels for the storage of wash-deck gear.

Chain-lockers. Receptacles for the chain cables of the ship, usually forward of the main-mast in the main-hold.

Chain-pipes. Iron linings of the holes through which the cables are led in passing from one deck to another.

Chain-plates. Iron plates for securing lower dead-eyes to ship's side.

Channels. Ledges of plank projecting from the side to give additional spread to the lower shrouds.

Chess-trees. Pieces of timber bolted in the top-sides, with sheaves for fore and main sheets, after guys. etc. Those for the fore and main sheets are known also as fore and main sheet "chocks."

Cleats. Pieces of wood with projecting arms, used for belaying ropes.

Coaming. A raised boundary to hatchways, to keep water from getting down, etc.

Cockpit. A space below the after hatchway under the berth-deck; usually the forward end of the after passage.

Compressor. In its simplest form, an iron lever fitted below each chain-pipe, the chain is controlled when running out by being, jammed between the compressor arm and edge of the chain-pipe.

Counter. The rounding of the stern over the run.

Cross-trees. Thwartship timbers supported by the bibbs and trestle-trees to sustain the frame of the top constitute the lower cross-trees. Top-mast cross-trees resting on the top-mast trestle-trees, extend the top-gallant shrouds.

Cutwater. The forward part of a ship's prow, forming the forward edge of the stem.

Dagger-knee. A knee which is inclined diagonally, usually to clear a port. Davits. Cranes projecting from the ship's side to hoist boats, etc.

Deadeye. A round flattish wooden block encircled by an iron "strap" and pierced with holes to receive a laniard by means of which rigging and stays are set up taut.

Dead-wood. Timber built up on top of the keel to give solid wood for supporting the heels of cant frames.

Decks. The different platforms of ships.

Dispensary. The ship's pharmacy, usually placed on starboard side of berth-deck forward of warrant officers' rooms, may also be in or near sick-bay.

Dolphin-striker. A small spar projecting downward from below the bowsprit to extend certain rigging of the head-booms and keep the latter in place.

Eye-bolt. A projecting bolt of which the head is fashioned into an eye, used for hooking tackles, etc.

Fid. A bar of iron or wood which passes through a *fid-hole* in the heel of a mast and rests on the trestle-trees on either side.

Fife-rail. Rails placed around each mast, fitted with belaying-pins to belay ropes.

Fish-davit. A movable piece of timber or iron projection, used to raise the fluke of an anchor and place it on the bill-board.

Fishes. Pieces of wood or iron used in effecting temporary repairs with injured masts, yards, etc.

Floor-timbers. Timbers of the frames which lie directly across the keel. Fore and Aft. Lying in the direction of the ship's length.

Forecastle. The upper-deck of a man-of-war forward of the after part of the fore-channels.

Fore-foot. The forward end. of the keel.

Fore-hold. The forward part of the hold, usually extending from abaft the fore-passage to about midway between fore and main masts.

Fore-passage. A passageway below the berth-deck leading to the general store-room and with entrances on either side to various special store rooms, sail-room, etc.

Fore-peak. The narrow part of a vessel's hold close to the bow and under the lowest deck, often accessible only from the general store-room.

Funnel. An iron band at a mast-head around which the rigging fits.

Futtock-plates. Iron plates to which the deadeyes of the topmast rigging and futtock-shrouds are secured.

Futtocks. Timbers of the frame between the floors and top-timbers.

Gammoning. The lashing or iron strap by which the bowsprit is secured to the stem.

Gangway. The spar-deck on each side of the booms between the quarter-deck and forecastle. Also an open space through the bulwarks as a passageway in and out of the ship.

General Store-room. Is situated below the berth-deck and at the forward end. of the fore-passage.

Gooseneck. A bent piece of iron used to connect a boom to a mast by entering an eye-bolt or clamp, and capable of movement at the curve.

Grating. An open latticed covering for hatches, etc.

Gripe. A piece bolted on forward of the stem, forming the lower end of the cut water.

Gun-deck A covered deck of a man-of-war carrying the whole or a portion of her battery. When the guns are carried on the upper-deck, its name as spar-deck remains unchanged.

Gun-room. Obsolete expression for the quarters of the commissioned officers.

Gunwale. The covering-piece of the heads of the timbers in a small vessel, or boat.

Half-deck. That part of the gun-deck between the main and mizzen masts on each side.

Hammock-nettings. Trough-shaped receptacles along the rail on either side, in which the hammocks are stowed. A net-work of ropes was formerly used for this purpose, hence the term; other nettings will be described, as used.

Hanging-knee. Knee placed vertically under a deck-beam.

Hatch. An opening in a deck, forming a passage from one deck to another, and into the holds.

Hawse-buckler. A plate used for closing the opening of the hawse-hole.

Hawse-holes. Holes in the bows of the ship through which pass the cables.

Hawse-pipe. Iron lining of the hawse-holes to take the chafe of the cables.

Hawse-plug. Plugs which fill the hawse-pipes to prevent the entrance of water when the cables are unbent. Usually made of canvas and stuffed, then termed "jackasses."

Head-board. Boards placed at the forward and after ends of the hammock-nettings.

Helm. Strictly, the bar by means of which the rudder is moved from side to side. Usually understood to mean the rudder, tiller, and wheel, or the whole of the steering arrangement.

Hold. The interior part of ship in which the stores or cargo, etc., are stowed. In a man-of-war if there are two holds the forward one is called the fore-hold and the after one, whatever its position, the main hold.

Horse-block. A small raised platform abreast the mizzen-mast, for the use of the officer of the deck when the ship is not supplied with a bridge.

Hounds. A projection on a mast for the trestle-trees to rest upon.

Hull. The main body of the ship.

Inboard. In the interior of the ship, as distinguished from *outboard*.

Keelson. A timber in the interior of the ship bolted on over the keel and floor timbers.

Knight-heads. Strong uprights on each side of the upper part of the stem to strengthen the bow and support the bowsprit.

Ledges (29). Light beams, parallel to the deck-beams butting on the clamps and carlings.

Light-boxes. Frames in which are set the side-lights of a vessel when under way.

Limbers. Gutters on each side of the keelson to allow the water to pass into the pump-well. Limber-boards, the covering of the limbers.

Life-buoy. An apparatus for the assistance of those who may fall overboard.

Locker. A drawer or chest that may be closed with a lock. *Shot-locker*, a compartment in the hold for storing shot; *chain-locker*, a similar compartment for the chain-cables.

Magazine. The store-room for the ship's powder, usually aft, under the wardroom, although many ships have two magazines, in which case one is forward and near the fore-passage.

Main-deck. A name given to the gun-deck of a vessel-of-war, and to the upper gun-deck of a two-decker.

Main-hold. That portion of the hold which extends from a short distance forward of the main-mast to the break of the orlop-deck.

Manger. Part of the deck divided off forward to prevent any water from running aft that may enter through the hawse-holes.

Manger-board. A plank running across the deck a short distance abaft the hawse-pipes, the after boundary of the manger.

Mast-coat. A canvas-covering fitted around the mast and over the wedges to prevent leakage around the mast.

Naval-pipe. Same as chain-pipe.

Oakum. Old rope picked to pieces, like hemp, used in caulking.

Orlop-deck. Usually a half-deck extending aft from the main-hold, a distance depending greatly upon the shape of the after body.

Outboard. On the outside of the ship, in contradistinction to *inboard*.

Partners. The framing around a mast-hole, to take the direct strain of the mast and mast-wedges.

Pawl. An iron arm on a capstan to keep it from recoiling.

Pin-rail. A railing on each side of the ship abreast of the masts, fitted with belaying pins for securing ropes.

Pay. To pay a seam is to pour hot pitch and tar into it after it has been caulked.

Poop. A deck raised above the after part of the spar-deck, reaching forward to the mizzen-mast.

Port. An opening cut in the side of the ship through which a gun may be discharged.

Port. The left side of a ship looking forward, as distinguished from starboard.

Pump-well. The part of the bilge upon which the suction of the pump acts directly.

Quarter-deck. Usually that part of the spar-deck which extends from the stern to the main-mast.

Quarter-gallery. Projections from the quarters of a vessel.

Rake. The inclination of a mast, etc., from a perpendicular direction to the keel.

Riding-bitts. The bitts around which the ship's cables are taken.

Ring-bolts. Eye-bolts having a ring through the eye of the bolt.

Rudder. The instrument by which a ship is steered.

Run. The narrowing of the after part of the ship.

Sail-room. Storage-room for spare sails, hammocks, and sail-maker's stores. In modern ships usually opens into the after-passage; some vessels have forward sail-rooms in fore-passage.

Sampson-knee. A heavy timber forward of the riding-bitts which serves to strengthen the latter.

Shell-room. Storage-room for explosive projectiles; when but one on board, is usually under the orlop near the after-hatch.

Shore. A post or timber used as a temporary support.

Sick-bay. The hospital of the ship, usually situated forward on the berth-deck.

Scuppers. Holes cut through the waterways and side to allow water to run off the decks.

Scuttle. A small circular aperture in a deck not intended for the passage of persons, through which powder, etc., may be passed from one deck to another.

Sheathing. Usually understood to mean a covering of copper, felt, etc., placed over a portion of the ship's surface to protect it. Copper sheathing covers the immersed part of a ship to protect it from marine growth.

Spar-deck. The upper deck of a ship-of-war.

Spirketing. The inside planking of a ship extending from the lower edges of the gun-ports to the waterways.

Spirit-room. A name formerly given to the paymaster's store-room in the after-part of the after-hold, reserved for stowage of spirits. The name applies at present to the paymaster's store-room for dry provisions.

Stanchions. Uprights placed under deck-beams to support them in the centre.

Starboard. The right side of a ship looking forward, as distinguished from port.

Steerage. The quarters of junior officers and clerks, situated outside the wardroom on either side of the deck, the space between the two steerage-rooms being known as the steerage-country.

8

Stem. The forward boundary of a ship, the continuation of the keel to the height of the deck.

Steps of Mast. Places into which the lower ends or *heels* of lower masts are secured or stepped. The fore and main masts are stepped at present in iron steps fitted over the main-keelson, with flanges to the sister-keelsons. The mizzen-mast step is a piece of timber secured to the orlop or berth deck beams.

Stern. The after-part of the ship.

Stern-post. The after-boundary of the ship, a continuation of the keel, tenoned into the latter and secured to it in addition by composition plates.

Sweep-pieces. Ledges of wood hinged to the inner edges of gun-ports to give additional facility in training the guns.

Taffrail. The rail around a ship's stern.

Tenon. The end of one piece of wood diminished and cut with shoulders to fit in a hole of another piece, called a mortise.

Thole-pin. Pins fitted in the gunwale of a boat, to be used with a rope ring or grommet as a rowlock.

Thwart. A cross-piece in a boat, used as a seat by the oarsmen.

Tiller. A bar of wood or iron which fits into the rudder-head and by which the steering is effected. (See Helm.)

Top. A platform at the eyes of the lower rigging, supported by the trestle-trees and cross-trees; the top-mast rigging sets up at each side of the top.

Top-gallant Forecastle. A deck raised over the forward end of the spar-deck extending from the bows nearly or quite to the fore-mast.

Top-rim. The forward edge of a top, rounded to prevent chafe.

Transom. A beam extending across the after-part of the ship.

Tree-nail. Pin of hard wood used as a fastening in the place of a metallic bolt.

Trestle-trees. Fore and aft pieces on each side of a mast resting on the hounds to support the rigging, cross-trees, etc.

Truck. A small wooden cap on a flag-staff or mast-head with holes or sheaves for halliards. A mast-head truck is also fitted to receive the spindle of the lightning-rod.

Ward-room. The quarters of the commissioned officers of a ship, usually occupying the after-part of the berth-deck. The rooms on the starboard side occupied by the line officers, those on the port side by the staff officers-the intervening space is styled the ward-room country.

Warping-chock. A block of wood, or metal casting, scored to receive a towline. Bridle-ports are fitted with such chocks, which can be removed when not in use.

Warrant-Officers' Rooms. Usually on the berth-deck, two on each side, forward of the steerage. The boatswain and gunner occupy the starboard, the carpenter and sail-maker the port rooms.

Waterways. Pieces of timber placed over the tops of the beams and secured to the beams and ship's side, filling the angle between the beams and the inside of the frame-timbers.

Wheel. A wheel to the axle of which are connected the tiller- or *wheel*-ropes by which the rudder is moved in steering.

Weigh. To weigh anything is to raise it-to weigh anchor.

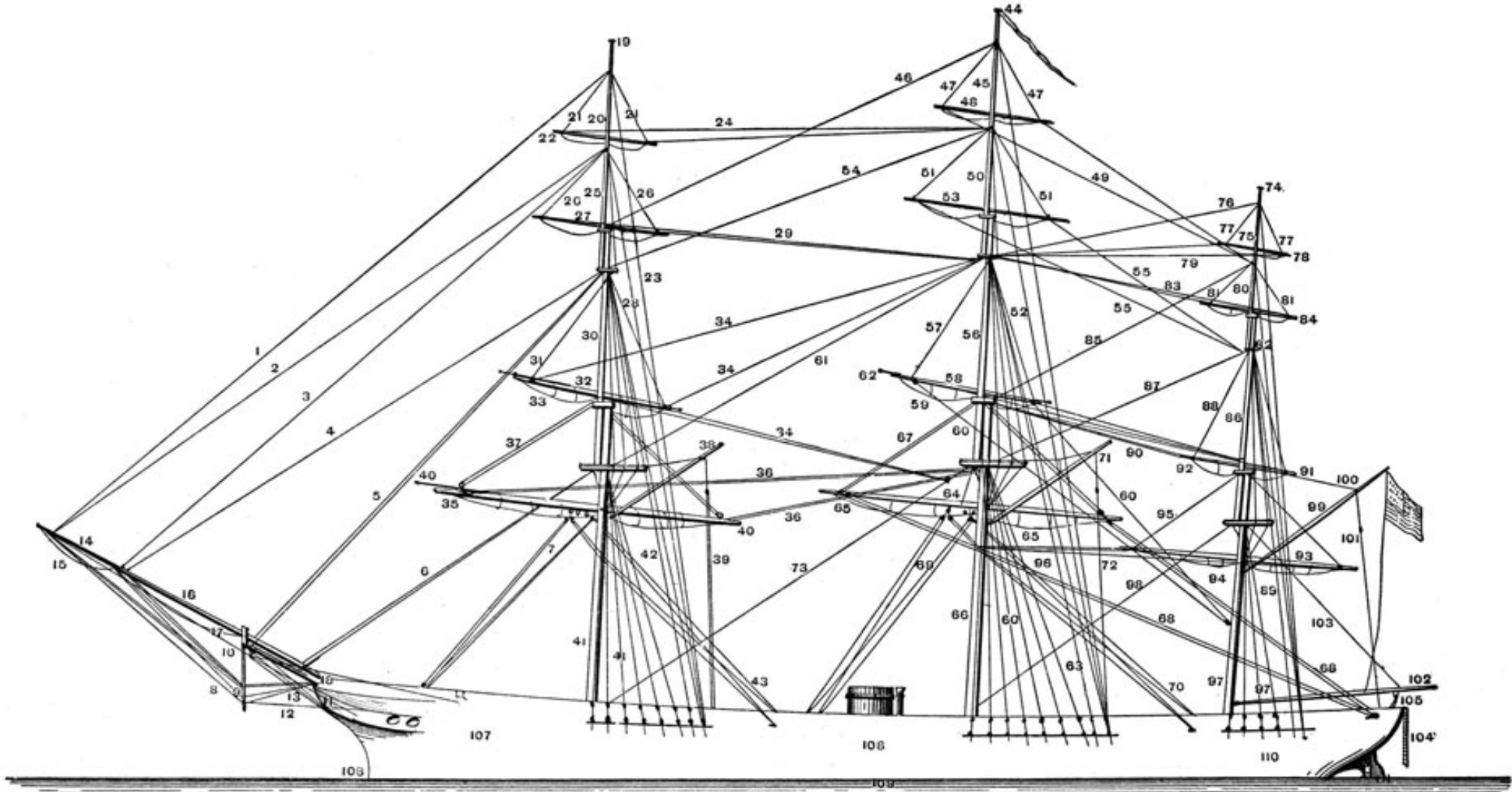
Whiskers. Small spars projecting on either side of the bowsprit from the bees, extending the jib and flying-jib guys.

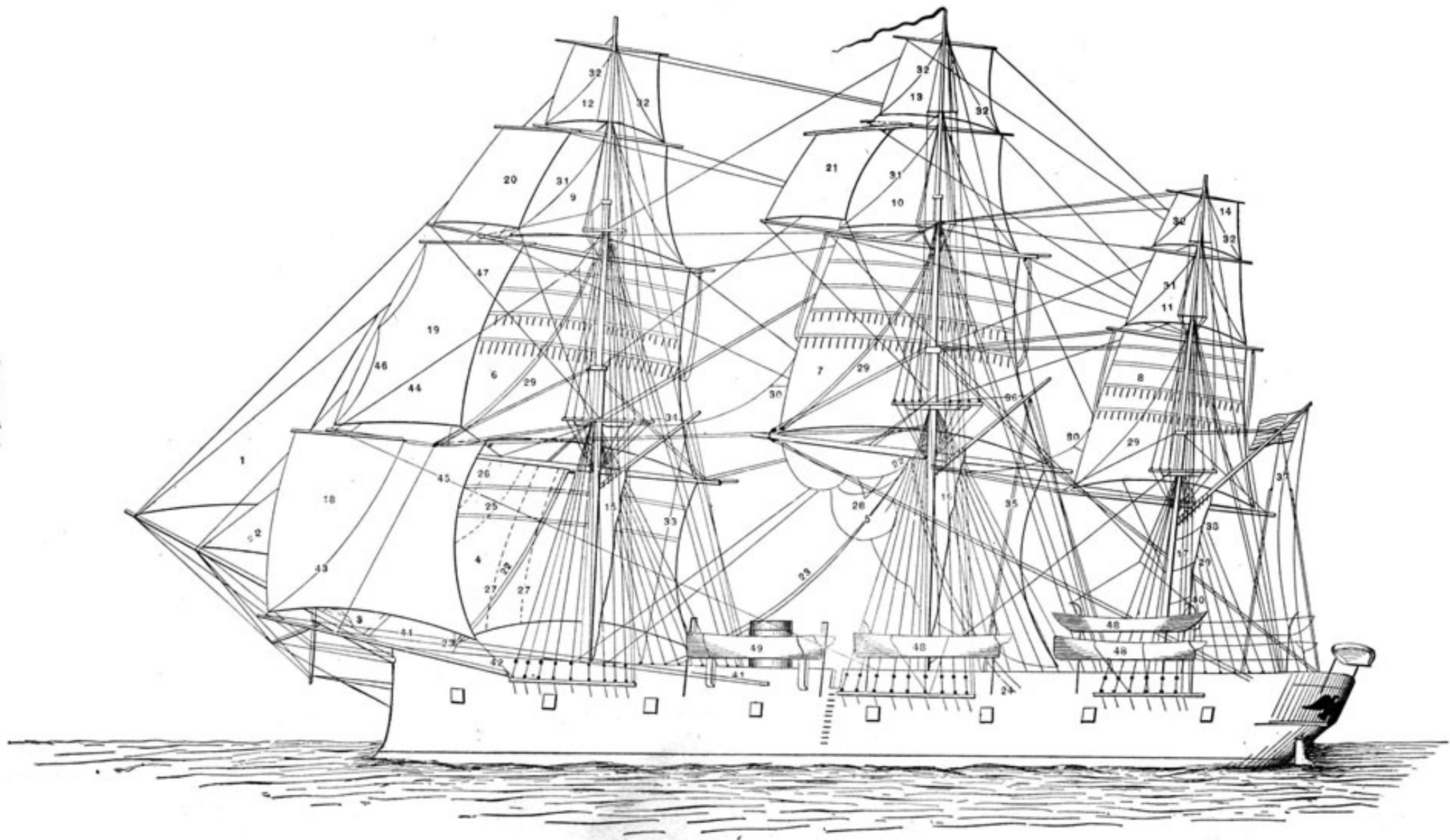
Wings of the Hold. That part of the hold or orlop which is nearest to the side.

Wythe. An iron fixture on the end of a mast or boom, bearing a ring through which another mast or boom is rigged out. Pronounced *with*.

Yoke. A cross-piece of timber or metal fitted on the rudder-head when a tiller cannot be used.

Plate 2





Spars and Rigging. The names of the spars and rigging of the ship are given in the references to Plate 2.

REFERENCES.

1. Fore royal stay.
2. Flying jib stay.
3. Fore topgallant stay.
4. Jib stay.
5. Fore topmast stays.
6. Fore stays.
7. Fore tacks.
8. Flying martingale.
9. Martingale stay.
10. Jib guys.
11. Jumper guys.
12. Back ropes.
13. Bobstays.
14. Flying jib boom.
15. Flying jib foot ropes.
16. Jib boom.
17. Jib foot ropes.
18. Bowsprit.
19. Fore royal truck.
20. Fore royal mast.
21. Fore royal lifts.
22. Fore royal yard.
23. Fore royal backstays.
24. Fore royal braces.
25. Fore topgallant mast and rigging.
26. Fore topgallant lifts.
27. Fore topgallant yard.
28. Fore topgallant backstays.
29. Fore topgallant braces.
30. Fore topmast and rigging.
31. Fore topsail lift.
32. Fore topsail yard.
33. Fore topsail foot ropes.
34. Fore topsail braces.
35. Fore yard.
36. Fore brace.
37. Fore lifts.
38. Fore gaff.
40. Fore topmast studding sail booms.
41. Foremast and rigging.
42. Fore topmast backstays.
43. Fore sheets.
44. Main truck and pennant.
45. Main royal mast and backstay.
46. Main royal stay.
47. Main royal lifts.
48. Main royal yard.
49. Main royal braces.
50. Main topgallant mast and rigging.
51. Main topgallant lifts.
52. Main topgallant backstays.
53. Main topgallant yard.
54. Main topgallant stay.
55. Main topgallant braces.
56. Main topmast and rigging.
57. Topsail lifts.
53. Topsail yard.
59. Topsail foot ropes.
60. Topsail braces.
61. Topmast stays.
62. Main topgallant stunsail booms.
63. Main topmast backstay.
64. Main yard.
65. Main foot ropes.
66. Main mast and rigging.
67. Main lifts.
68. Main braces.
69. Main tacks.
70. Main sheets.
71. Main trysail gaff.
72. Main trysail vangs.
73. Main stays.
74. Mizzen royal truck.
76. Royal stay.
77. Royal lifts.
78. Royal yard.
79. Royal braces.
80. Mizzen topgallant mast and rigging.
81. Mizzen topgallant lifts.
82. Mizzen topgallant backstays.
83. Mizzen topgallant braces.
84. Mizzen topgallant yard.
85. Mizzen topgallant stay.
86. Mizzen topmast and rigging.
87. Mizzen topmast stay.
88. Mizzen topsail lifts.
89. Mizzen topmast backstays.
90. Mizzen topsail braces.
91. Mizzen topsail yard.
92. Mizzen topsail foot ropes.
93. cross-jack yard.
94. cross-jack foot ropes.
95. cross-jack lifts.
96. cross-jack braces.
97. Mizzen mast and rigging.
98. Mizzen stay.
99. Spanker gaff.
100. Peak halliards.
101. Spanker vangs.
102. Spanker boom.
103. Spanker boom topping lift.
104. Jacob's or stern ladder.
105. Spanker sheet.
106. Cutwater.
107. Port bow.
108. Port beam.
109. Water line.
110. Port quarter.
111. Rudder.

Sails. The names of the sails and certain running rigging of a ship are given in the following references to Plate 3.

NAMES OF SAILS.	19. Fore topmast studdingsail.	33. Fore trysail vang.
	20. Fore topgallant studdingsail.	34. Peak span.
1. Flying jib.	21. Main topgallant studdingsail.	35. Main trysail vang.
2. Jib.		36. Peak span.
3. Fore topmast staysail.		37. Spanker vang.
4. Fore course or foresail.	GEAR OF COURSES.	38. Throat brail.
5. Main course or mainsail.		39. Middle brail.
6. Fore topsail.	22. Clew Garnets.	40. Foot brail.
7. Main topsail.	23. Tacks.	41. Lower studdingsail outhaul
8. Mizzen topsail.	24. Sheets.	42. Lower studdingsail sheet.
9. Fore topgallant sail.	25. Inner leechline.	43. Lower studdingsail clew-line.
10. Main topgallant sail.	26. Outer leechline.	44. Outer halliards.
11. Mizzen topgallant sail.	27. Buntlines.	45. Topmast studdingsail tack.
12. Fore royal.	28. Bowline bridles.	46. Topmast studdingsail downhaul.
13. Main royal.		47. T'gllt stuns'l tack.
14. Mizzen royal.	GEAR OF TOPSAILS, ETC.	48. Quarter boat.
15. Fore trysail.		49. Waist boat.
16. Main trysail.	29. Clewlines.	
17. Spanker.	30. Bowline and bridles.	
18. Lower studdingsail.	31. Topgallant clewline.	
	32. Royal clewline.	

Rig of Vessels (compare Plate 4). Vessels are divided according to their rig into numerous classes, of which the following may be mentioned as the principal types usually met with at sea:

The Ship (1). Three masted, square rigged on all three masts.

The Barque or Bark (2). Three masted, square rigged fore and main, fore and aft rig on mizzen.

The Barkentine (3). Three masted, square rigged fore, fore and aft rig main and mizzen.

The Brig (5). Two masted, square rigged.

The Brigantine. Same as brig but without a square mainsail.

The Hermaphrodite Brig (6). Two masted, square rigged fore, fore and aft rig main.

The Topsail Schooner (7). Two masted, square rigged forward, but with a fore and aft foresail.

The Schooner. Two masted (8), three masted (4), or four masted fore and aft rig.

The Sloop (9). One masted, fore and aft rig.

NOTE. A vessel is said to be square rigged on a certain mast, when the sails set on that mast are bent to yards, and fore and aft rigged when the sails are bent to gaffs.

The topsail yards of merchantmen are almost invariably double, the topsail being in two parts, the lower part bent to the lower topsail yard and not hoisted, the upper portion bent to the upper yard and hoisted, as in the case of a single topsail. The clews, or lower corners, of the upper topsail are shackled to the yard arms of the lower topsail yard.

Plate 4

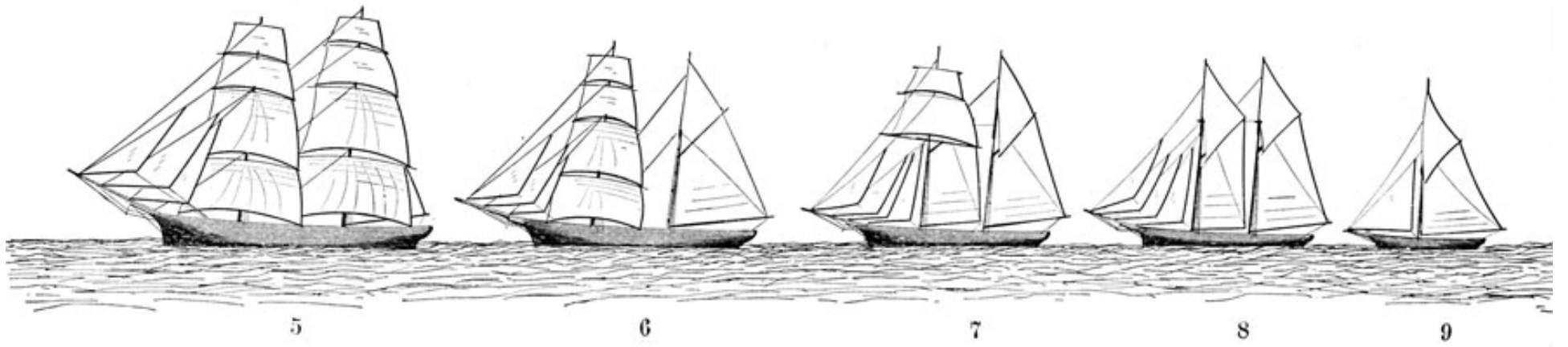
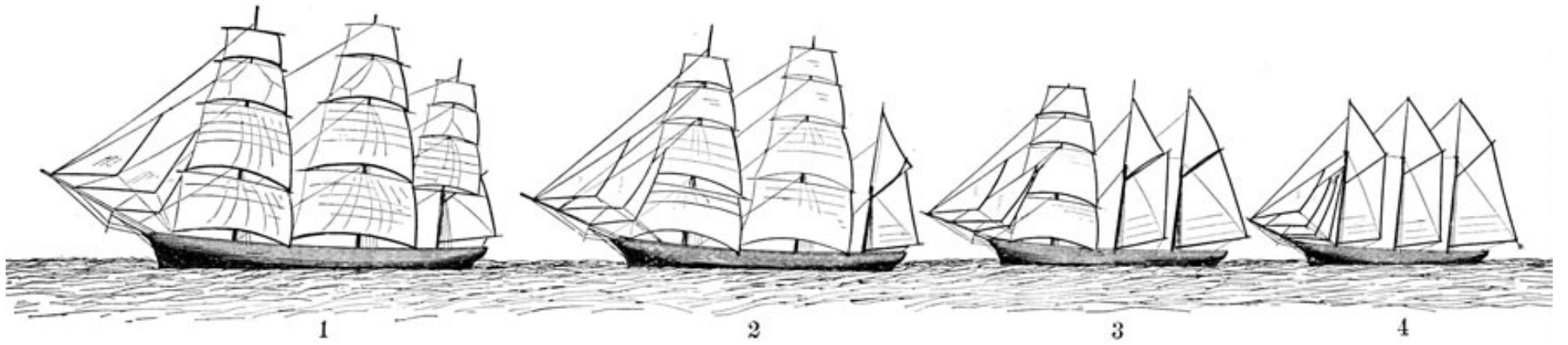
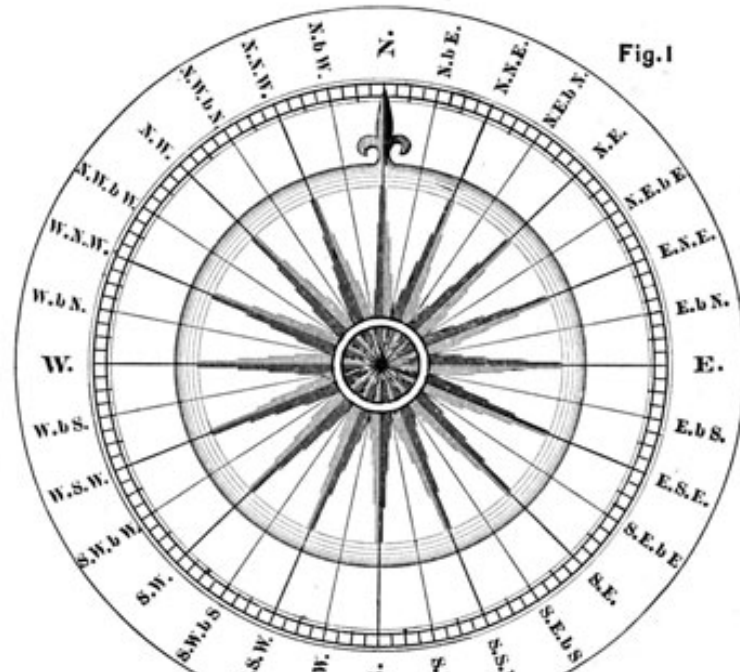
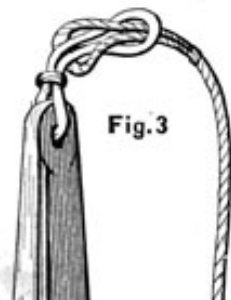
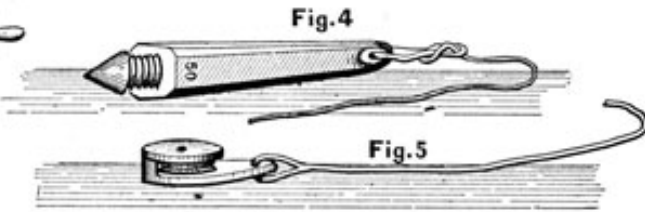
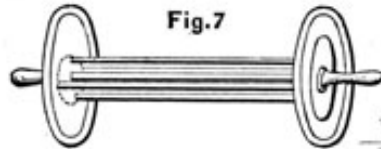
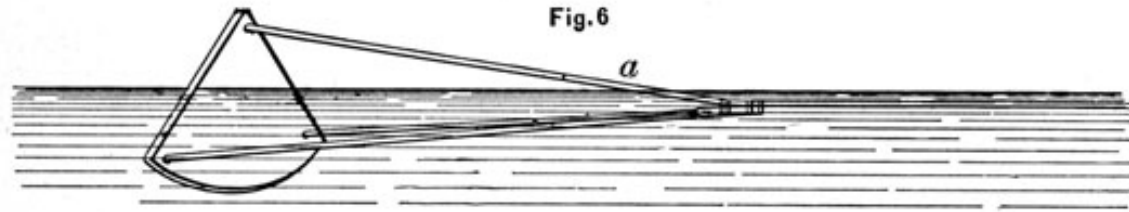
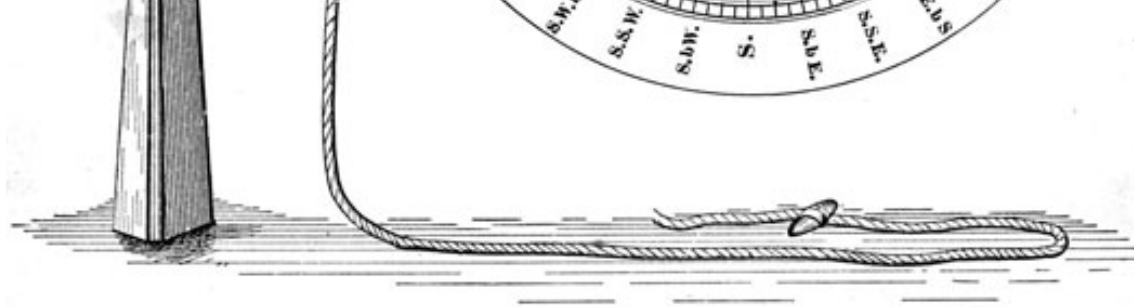


Plate 5





CHAPTER II.

THE COMPASS.-THE LEAD.-THE LOG.

The Compass- A piece of steel which has been touched by a magnet, if free to move on a pivot, will point in a definite direction. To this direction, as a standard, all others may be referred, and any desired course thus followed.

The Mariner's Compass is based upon this principle. It consists of the *needle*, which is attached to the under side of a card, Fig. 1, representing the horizon, and graduated with the thirty-two "points" of the compass. The North end, or pole, of the needle is fixed under the North point of the card. The needle and card are balanced on a pivot fixed vertically in the compass-box, or bowl, and the whole is protected by a glass covering.

As the North mark of the compass-card always points with the needle to the North, the other marks will of course point to their respective parts of the horizon.

The variation of the compass and its local errors are not noticed here, as they may be referred to in any book on Navigation.

The *Lubber's Point* is a vertical line drawn on the inside of the bowl of the compass to correspond with the vessel's head; the point of the card coinciding with it shows the course steered, or the direction in which the ship is heading.

To Box the Compass is to name the points in regular succession, beginning at one point and ending at the same; thus, commencing with north and going around *with the sun*, say:-

North,	South-East,
North by East,	South-East by South,
North North-East,	South South-East,
North-East by	South by East,
North;	South,
North-East,	South by West,
North-East by East,	South South-west,
East North-East,	South-West by
East by North,	South,
East,	South-West,
East by South,	South-West by West,
East South-East,	West South-West,
South-East by East,	West by South,

12

West,	North-West,
West by North,	North-West by
West North-West,	North,
North-West by	North North-West,
West,	North by West,
	North.

Each point is further divided into half-points and quarter-points, and the fractional points are named upon the same principle as the points themselves; thus:-

N. 1/4 E.	N. E. 1/4 E.
N. 1/2 E.	N. E. 1/2 E.
N. 3/4 E.	N. E. 3/4 E.
N. by E.	N. E. by E.
N. by E. 1/4 E.	N. E. by E. 1/4 E.
N. by E. 1/2 E.	N. E. by E. 1/2 E.
N. by E. 3/4 E.	N. E. by E. 3/4 E.
N. N. E.	E. N. E.
N. N. E. 1/4 E.	E. N. E. 1/4 E.
N. N. E. 1/2 E.	E. N. E. 1/2 E.
N. N. E. 3/4 E.	E. N. E. 3/4 E.
N. E. by N.	E. by N.
N. E. 3/4 N.	E. 3/4 N.
N. E. 1/2 N.	E. 1/2 N.
N. E. 1/4 N.	E. 1/4 N.

N. E. E., &c., &c.

A quarter-point (or half-point) can obviously be named with reference to either one of the nearest whole points. Thus N. 1/4 E. would be defined also as N. by E. 3/4 N., and E. N. E. 1/2 E. would be recognized as E. by N. 1/2 N.

The following are the usual rules for naming quarter-points:-

1st. From East or West to the nearest whole point, use for quarter-points that name which ends with the word North or South. Thus, E. 1/4 S., not E. by S. 3/4 E.

2d. From N. E., N. W., S. E., or S. W., to the nearest whole point use that name which ends with the nearest cardinal point. Thus, N. E. 1/2 N., not N. E. by N. 1/2 E.; N. W. 1/4 W., not N. W. by W. 3/4 N.

3d. In all other cases use that name of the quarter or half-point which ends with the word East or West. Thus, E. S. E. 1/2 E., not E. by S. 1/2 S.

A *Dumb Compass* is used at the mast-heads, taffrail, &c., for taking relative bearings. It consists of a compass-card painted on a board or cut on a copper plate.

Relative Bearings. In referring to the position of an object, the direction of the wind, &c., with reference to the ship, use is frequently made of what are called relative bearings, instead of giving the directions in compass-points.

13

In Fig. 2 a ship is represented as heading North. A lighthouse or other object if seen bearing North would also be said to bear, from that ship: Ahead.

If seen bearing N. by E.: One point on starboard bow.

Bearing N. N. E.: Two points on starboard bow.

Bearing N. E. by N.: Three points on starboard bow.

Bearing N. E.: Broad off starboard bow.

Bearing N. E. by E.: Three points forward of starboard beam.

Bearing E. N. E.: Two points forward of starboard beam.

Bearing E. by N.: One point forward of starboard beam.

Bearing East: Abeam.

Bearing E. by S. One point abaft starboard beam.

Bearing E. S. E.: Two points abaft starboard beam.

Bearing S. E. by E.: Three points abaft starboard beam.

Bearing S. E.: Broad off starboard quarter.

Bearing S. E, by S.: Three points on starboard quarter.

Bearing S. S. E.: Two points on starboard quarter.

Bearing S. by E.: One point on starboard quarter.

Bearing South: Astern.

And similarly at N. by W., N. N. W. &c., one point on port bow, two points on port bow, &c., &c.

To find the direction of the wind, when ship is close hauled.-A square-rigged ship, when close hauled, can usually lie no nearer the wind than six points; therefore, if a ship be close hauled on the starboard tack, and her head at North, count six points thence to the right hand, or towards East, and you will find the wind at E. N.E. The wind then forms with the keel an angle of six points, so that if a line at Fig. 2, Plate 6, represents the ship's keel, (c) will be the yard when braced up, and (d) the direction of the wind. In practice the yard is braced up sharper, to make the sail stand to better advantage.

When the ship is on the port tack with her head North, the points are counted on the opposite or left side, and the wind is W. N.W. If the ship's head be put to any point of the compass, counting six points to the right or left hand, according. as the ship is on the starboard or port tack, will always give the direction of the wind when the vessel is close hauled.

When the wind is E. by N., in Fig. 2, the ship is then one point free, because her head is seven points from the wind. With the wind East in the figure, it is said to be two points free, or abeam, as shown in the remarks on relative bearings. If the wind is at S. in the figure, it is said to be aft.

After learning to box the compass with the sun, go around against the sun, or from North towards West, and practise with such questions as the following: Ship on the port tack, heading S. W. $\frac{3}{4}$ W., how will she head on the other tack? With the wind at S.W. and steering due East,

14

the ship is hauled up, two points and a half, how will she head? Close hauled, with the port tacks aboard, heading S. S.E., you *bear up*, keeping away six points, how will the ship head, and how will the wind be with reference to the ship's beam? Ship heading N. N.E. on the starboard tack, a lighthouse is reported from aloft bearing two points abaft the lee beam, how will it bear by compass, &c., &c.?

THE LEAD.

Soundings, to ascertain the depth of water on entering or leaving a port, or in any case where there is supposed to be less than twenty fathoms of water, are taken by the *hand lead*, Fig. 3, a quartermaster or forecandle-man being stationed in the main chains for the purpose; the lead weighing, from seven to fourteen pounds, and the line being from twenty. to thirty fathoms in length. Hand lead lines are marked as follows:

At 2 fathoms from the lead, with 2 strips of leather.
At 3 fathoms from the lead, with 3 strips of leather.
At 5 fathoms from the lead, with a white rag.
At 7 fathoms from the lead, with a red rag.
At 10 fathoms from the lead, with leather, having a hole in it.
At 13 fathoms from the lead, as at 3.
At 15 fathoms from the lead, as at 5.
At 17 fathoms from the lead, as at 7.
At 20 fathoms from the lead, with 2 knots.
At 25 fathoms from the lead, with one knot.
At 30 fathoms from the lead, with three knots.
At 35 fathoms from the lead, with one knot.
At 40 fathoms from the lead, with four knots. And so on.

These are known as the "marks." The numbers omitted, as 1, 4, 6, 8, &c., are called the "deeps," and they are spoken of together as the "marks and deeps of the lead line."

All lead lines should be marked when wet.

Soundings by the hand-lead are taken while the vessel has headway on, the leadsman throwing the lead forward, and getting the depth as the vessel passes, while the line is nearly perpendicular. He communicates to the officer the soundings obtained, thus:

If the depth corresponds with either of the above marks, he says, "*By the mark 5 or 7.*" If the mark is a little below the surface, he says, "*Mark under water 5 or 7.*" If the depth is greater, or one half more than any of the marks, he says, "*And a quarter,*" or "*And a half 5 or 7.*" If the depth is a quarter less, he says, "*Quarter less 5 or 7.*" If he judges by the distance between any two of the marks

that the depth of water is 4, 6, 8, 9, 11, 12, 14, 16, 18, 19, or 21 fathoms, he says, "*By the deep 4,*" &c.

On the hand-lead line there are nine "marks" and eleven "deeps."

Require the soundings to be given in a sharp, clear and decided tone of voice. In steamers, this is certainly the best plan, for while the old-fashioned "song" is being drawled out, the vessel may run ashore.

The Breast-band or Rope, generally the former, made of canvas, secured at both ends to the rigging, supports the body of the leadsman while heaving the hand-lead.

Besides the breast-band, it is a very good plan to have fitted, in connection with it, a tarpaulin apron, to cover the "leadsman" from the feet to the waist. This keeps him dry and adds much to his comfort.

On going into the chains for the purpose of sounding, the leadsman should see the breast-rope properly secured; his line clear, and the end made fast. If at night, he should take the distance from the breast-rope to the water's edge; then at each cast deduct this distance from the mark at hand and give it as the true sounding.

The Coasting Lead is used in depths from 25 to 100 fathoms, the lead weighing from 25 to 50 pounds.

The Deep-sea Lead is used in depths of over 100 fathoms, and weighs from 80 to 150 pounds.

Both coasting and deep-sea (pronounced "dipsey") leads are hollowed out at the base to receive an *arming* of tallow. When the lead strikes, the tallow becomes coated with sand, pebbles, shells or other substances which show the character of the bottom. This information, compared with the description of the sea bottom given on the chart, may prove of value in determining the ship's position. Instead of being hollowed out at the bottom, the deep-sea lead may have a specimen cup, of brass, at the end, as shown in Fig. 4. The coasting and deep-sea lines are marked alike as follows:

10 fathoms, one knot.

20 fathoms, two knots.

30 fathoms, 3 knots, &c., &c., and at every intermediate five fathoms by small strands. At 100 fathoms the line is marked with a piece of red bunting.

To Sound with the Deep-sea Lead. The men are ranged outside the vessel from the weather mizzen chains to the cathead. The line is passed forward outside and clear of everything. The lead is sent forward on deck, and the line bent to it by the captain of the fore-castle. The line is then hauled forward, each man collecting a coil of several fathoms in his hand, commencing forward, until the officer thinks there is line enough out. It is then snatched in a small snatch-block, Fig. 5, secured to the

after mizzen rigging, or to the weather spanker yang, the remaining part of it being coiled down in a tub or rack, or wound on a reel, clear for running. Everything being in readiness, and the vessel's headway sufficiently deadened, the officer orders, *Stand by! Heave!* The captain of the fore-castle heaves the lead as far forward as he can, and at the same time cries, *Watch-ho! Watch!* And each man, as the line runs out from his hand, holds it clear of the side, and repeats the cry, *Watch-ho! Watch!* In the mean while, the line runs out until the lead touches the bottom, or until a sufficient quantity has been run out to satisfy the officer that no bottom has been found. The men then *lay aft and man the line!* and walk forward with it; a petty officer being stationed by it, to note the depth of water by the first mark that comes in.

If bottom has been found, it will instantly be known by the line bringing up suddenly in running out, or by the arming on the lead after it is hauled up; by which the nature of the bottom is known.

To get sounding by the deep-sea lead while lying to in a gale, or in any case when the vessel drifts much to leeward, it is proper to pass the line from to windward around the stern, and then forward on the lee side, and to heave the lead from to leeward, which will bring the line nearly perpendicular by the time the lead touches the bottom.

In heaving the deep-sea lead, the men stationed in the chains should be cautioned not to let the line go until they feel the lead take it, for if the ship is in much shoaler water than was anticipated, it is thus detected at once.

Besides the common lead, there are a variety of "patents" for sounding; the one known as *Massey's lead*, being about the most successful. In this, a machine is attached to the lead, and a fan set in motion by its descent. The motion is communicated to a register wheel, and the number of fathoms corresponding to the depth of water is pointed out by an indicator. This lead should also have a good arming of tallow to bring up specimens of the bottom.

The Drift Lead. While at single anchor, it is proper always to have a lead somewhat heavier than the hand-lead, say from fourteen to twenty pounds, over the side, and resting on the bottom, with a man to attend it. Of course, this is only necessary in a stiff breeze, or at night. But in a vessel-of-war, it should be observed as a standing rule, without regard to the weather. By this you will have instant notice if the vessel parts her cable or drags her anchor.

THE LOG.

Various methods have been proposed for measuring the rate at which a ship sails; but that most in use is by the Log and Glass.

The Log is a flat piece of thin board, of a sectoral or quadrantal form, Figs. *6a* and *b*, Plate 5, loaded, on the circular side, with lead sufficient to make it swim upright in the water. To this is fastened a line, about 150 fathoms long, called the *log-line*, which is divided into certain spaces called *knots*, and is wound on a reel, Fig. 7, which turns very easily. The Glass is of the same form as an Hour-Glass, Fig. 8, and containing such a quantity of sand as will run through the hole in its neck in twenty-eight seconds.

Marking the Log-Line. Previous to marking a new Log-line, it is soaked in water for a few days, in order to get it in the condition it will be when in use. From fifteen to twenty fathoms is allowed for "stray-line;" and then the length of a knot determined (for the 28-second glass) by the following proportion, viz.: As the number of seconds in an hour is to the number of feet in a sea mile, so is the length of the glass to the length of a knot, or,

$$\begin{aligned} 3,600 \text{ s} : 6,086 \text{ ft.} &= 28 \text{ s} && : 47.33 \text{ ft.} \\ &&& : 47 \text{ feet } 4 \text{ inches;} \end{aligned}$$

therefore the length of the knot is 47 feet 4 inches for the 28-second glass.

The velocity of the ship is estimated in knots and tenths of a knot.

The limit of "stray-line" is marked by a piece of red bunting about six inches long, and each length of 47 feet 4 inches after that by a piece of fish-line with one, two, three, etc., knots in it, according to, its number from the "stray-line."

Each length of 47 feet 4 inches (the "knot") is subdivided into five equal parts, and a small piece of white bunting about two inches long is turned into the line at every two-tenth division thus formed.

Always, before leaving port, the Navigator has the line thoroughly soaked for a few days, and then all the marks placed at their proper distances. He also compares all the sand-glasses with a watch, and if any should be incorrect, he makes them run the proper time by taking out or putting in sand, as the case requires. During daylight, especially in very damp weather, it is preferable to use a watch to a sand-glass for noting the time. Errors of the glass due to moisture are commonly corrected by drying it at the galley.

Heaving the Log.-To find the ship's speed is

called *heaving the log*, and is thus performed: One man holds the reel, and another the glass; an officer of the watch throws the log over the ship's stern, on the lee side, and when he observes the stray line is run off (allowed to carry the log out of the eddy of the ship's wake), and the red rag is gone off, he cries, *Turn*; the glass-holder answers, *Turn*; and watching the glass, the moment it is run out, says, *Up*. The reel being immediately stopped, the last mark run off shows the number of knots, and the distance of that mark from the rail is estimated in tenths. Then the knots and tenths together show the distance the ship has run the preceding hour, if the wind has been constant. But if the wind has not been the same during the whole hour, or interval of time between heaving the log, or if there has been more sail set or handed, a proper allowance must be made. Sometimes, when the ship is before the wind, and a great sea setting after her, it will bring home the log. In such cases, it is customary to allow one mile in ten, and less in proportion if the sea be not so great. Allowance ought also to be made, if there be a head sea.

This practice of measuring a ship's rate of sailing, is founded upon the following principle, that the length of each knot is the same part of a sea mile;* as twenty-eight seconds is of an hour.

In heaving the log, you must be careful to veer out the line as fast as the chip will take it; for if it be left to turn the reel itself, it will come home and deceive you in your reckoning. You must also be careful to measure the log-line pretty often, lest it stretch and deceive you in the distance. Like regard must be had that the glass be just 28 seconds; otherwise no accurate account of the ship's way can be kept. The glass is much influenced by the weather, running slower in damp weather than in dry. The glass may be examined by a watch, as above stated, or by the following method:-Fasten a plummet on a line, and hang it on a nail, observing that the distance between the nail and middle of the plummet be $39 \frac{1}{8}$ inches; then swing the plummet, and notice how often it swings while the glass is running out, and that will be the number of seconds measured by the glass.

If the vessel's speed is greater than four knots the fourteen-second glass is used instead of the twenty-eight second, and the number of knots run out is doubled to ascertain the actual rate of sailing, as the line is graduated for the twenty-eight second glass. The twenty-eight and fourteen second glasses are called respectively the long and short glasses.

* A statute mile is 5,280 feet. To convert sea miles into statute miles, multiply the former by 1.153. To convert statute miles into sea miles, multiply by the decimal .868.

Plate 6

Fig.10

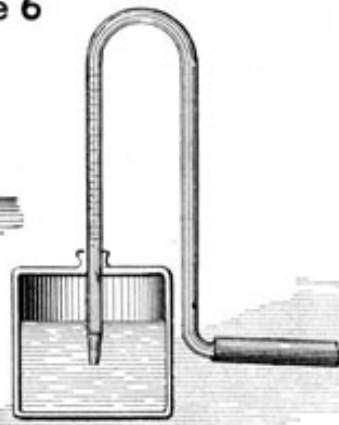
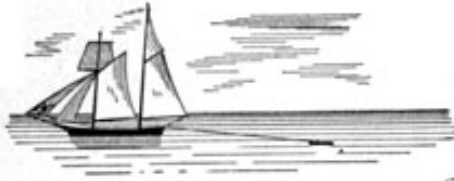


Fig.13

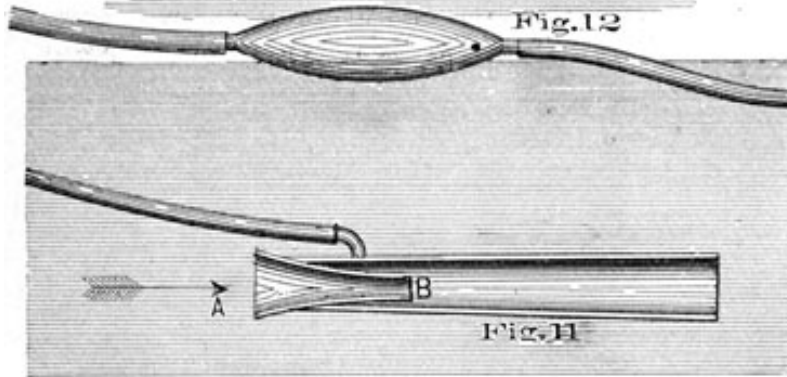


Fig.12

Fig.11

Fig.9

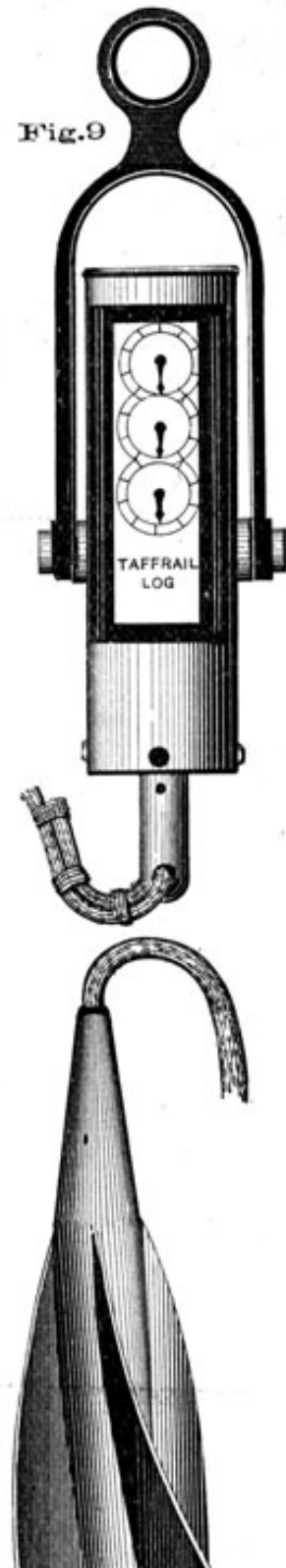
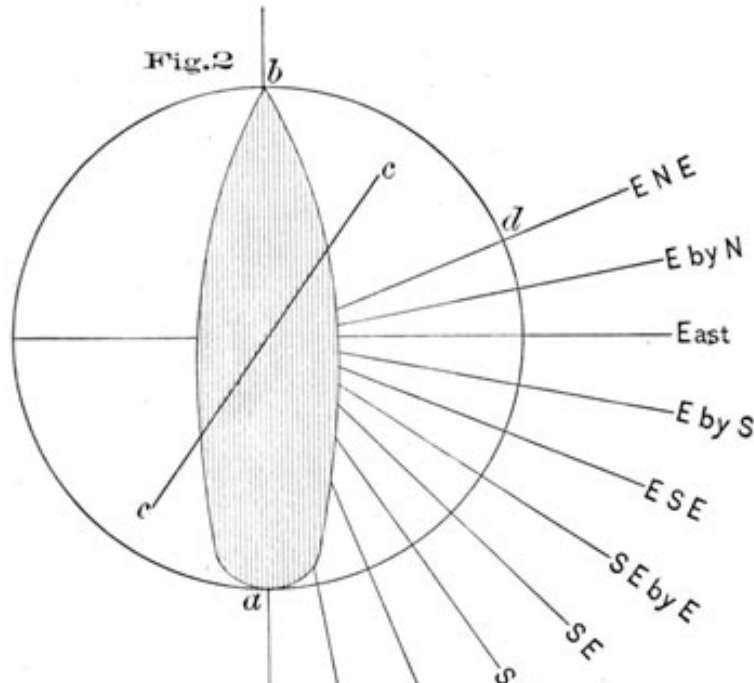


Fig.2



ENE

E by N

East

E by S

ESE

SE by E

SE



The Patent Log is now in constant use, especially on board steamers. It should be rigged out by a spar, so as to clear the wake, and care taken to haul it in whenever the ship is stopped.

Massey's Patent Log is composed of a brass wedge-shaped box, having within three cogged wheels, acting on each other in such proportion that a total revolution of one completes a division of the next (or one-twentieth), a revolution of the next, one-eighth, registering thus from one hundred and sixty miles to tenths, and decimal parts; the action is by the rotation of a spindle with four spirally-fixed wings (termed the rotation, or fly), which turns an endless screw in the box, acting directly on the decimal wheel. It is towed astern by a stout lead line of sixty fathoms, and is registered every time the course is changed, angles taken, &c., but should not be reset until the twenty-four hours have elapsed, or the ship anchors, or goes less than three knots-when it becomes uncertain from not towing horizontally.

When great accuracy is required it is well to use two logs, putting one overboard as the other is hauled up, as when the course is changed, etc.

The Taffrail Log, Fig. 9. This is a mechanical log of the same character as Massey's, but it has the advantage of towing only the fly, the registering apparatus being at the inboard end of the trailing line so that it can be easily read without hauling in the line. In one patent of this kind there is placed between the register and fly a conical hollow metal piece upon which the vibrations due to pitching are taken.

Registering logs are frequently made to strike a bell at every mile or five miles of the run.

Among the various speed indicators which, like the common log, are useful in showing *changes* of speed, the instrument invented by Ensign Hogg, U. S. Navy, has given very satisfactory results, and may be described as follows:

Fig. 10 shows a sailing vessel with the vacuum instrument represented in Fig. 11, towed astern by a hollow gum tube, the length of which for the largest vessels is 75 feet. The tube is supported in the water at low speeds by the buoy in Fig. 12. The mercurial gauge, Fig. 13, is on board the vessel; at present a metallic gauge is generally substituted.

The action of the speed indicator is as follows: The water rushing through the instrument at A, Fig. 11, causes a vacuum at the small end of the mouth-piece B. This vacuum communicates by means of the gum-tube with the vacuum-gauge on deck, and the greater the vacuum, the greater the speed. The graduations on the vacuum-gauge are found by experiment.

20

The only difference with a steamer is that the rubber tube is rigged out about three feet by an outrigger from the ship's side, and the vacuum instrument is towed alongside.

The Ground Log is the common log line with a hand-lead attached, and is used in tideways and currents, in soundings, to ascertain the vessel's speed *over the ground*.



[Next Part](#)

Copyright (C) 2006 [Historic Naval Ships Association](#)

All Rights Reserved

[Legal Notices and Privacy Policy](#)

Version 1.05, 18 Apr 06

CHAPTER III.

ROPE.

THERE are four varieties of rope in the United States naval service: that made of the fibres of the hemp plant; the Manilla rope, made of the fibres of a species of the wild banana; hide rope, made of strips of green hide, and wire rope.

In some countries, ropes made of horse hair, of the fibrous husk of the cocoanut, called coir-rope, and of tough grasses, are quite common. In our own country, rope has been made from the flax and cotton plants. The metals have also been put in requisition, copper-wire rope being used for particular purposes, principally for lightning conductors, and iron and steel wire are in general use for standing rigging; steel wire being some fifty per cent. stronger than iron wire of the same size.

Of the many vegetable substances that are adapted to rope-making, the best is hemp-hemp-rope possessing in a remarkable degree the essential qualities of flexibility and tenacity.

Hemp in its transit from its native fields to the ropewalk passes through the operations of *dew-rotting*, *scotching* and *hackling*. In the first process water dissolves the glutinous matter that binds the fibrous portion to the woody core, thus partly setting the fibres free; scotching breaks the stalk and separates it still further from the fibre, and hackling consists in combing out the hemp to separate the long and superior fibres from the short and indifferent ones or tow.

The hemp of commerce is put up in bundles of about 200 lbs. each. If good, it will be found to possess a long, thin fibre, smooth and glossy on the surface, and of a yellowish green color; free from "spills" or small pieces of the woody substance; possessing the requisite properties of strength and toughness, and inodorous.

Russian and Italian hemp are considered the best, for the generality of purposes. Rope made from the best quality of Russian hemp, is more extensively used in the navy than any other kind.

Italian hemp is only used in the navy for packing for engines, its cost being more than double that of Russian hemp.

The Native American dressed hemp, easily distinguished

by its dark grayish color, is preferred for many purposes, such as for marline, houseline, hambroline, and all cordage spun by hand, the fibre being finer-than that of the Russian hemp.

Cotton is a poor substitute for hemp, in rope-making, lacking its strength and durability. It retains moisture when once wet, and is liable to rot.

Flax is used sometimes for deep-sea sounding-lines, though reeled piano wire has replaced it for this purpose where great depths are measured.

Sail Twine is made of cotton or flax.

The size of Rope is denoted by its circumference, and the length is measured by the fathom. The cordage allowed in the equipment of a man-of-war ranges from 1 1/4 (15-thread) to 10 inches inclusive.

For a brief description of the process of rope-making, see Appendix A.

Varieties of Rope. In rope-making the general rule is to spin the *yarn* from right over to left. All rope yarns are therefore *right-handed*. The strand, or *ready*, formed by a combination of such yarns, becomes *left-handed*. Three of these strands being twisted together form a right-handed rope, known as *plain-laid* rope. Fig. 14, Plate 7.

White Rope. Hemp rope, when plain-laid and not tarred in laying-up, is called white rope, and is the strongest hemp cordage. It should not be confounded with Manilla. It is used for log-lines and signal halliards. The latter are also made of yarns of untarred hemp, plaited by machinery to avoid the kinking common to new rope of the ordinary make. This is called "*plaited stuff*," or "*signal halliard stuff*."

The tarred plain-laid ranks next in point of strength, and is in more general use than any other. The lighter kinds of standing rigging, much of the running rigging, and many purchase falls are made of this kind of rope.

Cable-laid or Hawser-laid Rope, Fig. 15, is left-handed rope of nine strands, and is so made to render it impervious to water, but the additional twist necessary to lay it up seems to detract from the strength of the fibre, the strength of plain-laid being to that of cable-laid as 8.7 to 6; besides this, it stretches

considerably under strain.

Back-handed Rope. In making the plain laid, it was said that the readyes were left-handed, the yarns and the rope itself being right-handed. If, instead of this, the ready is given the same twist the yarn has (right-handed), then, when brought together and laid up, the rope must come left-handed. This is called *left-handed* or *back-handed rope*. It is more pliable than the plain-laid,

Plate 7

Fig.14



Fig.15

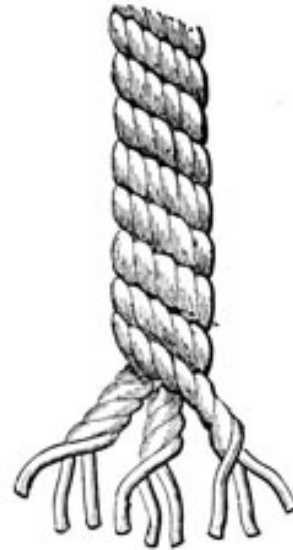
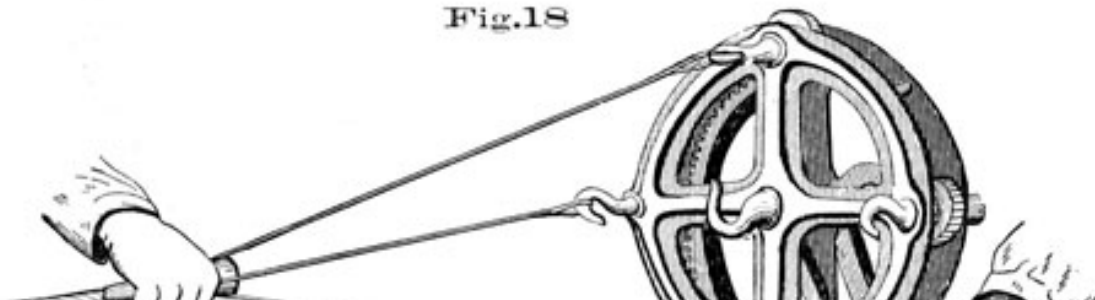
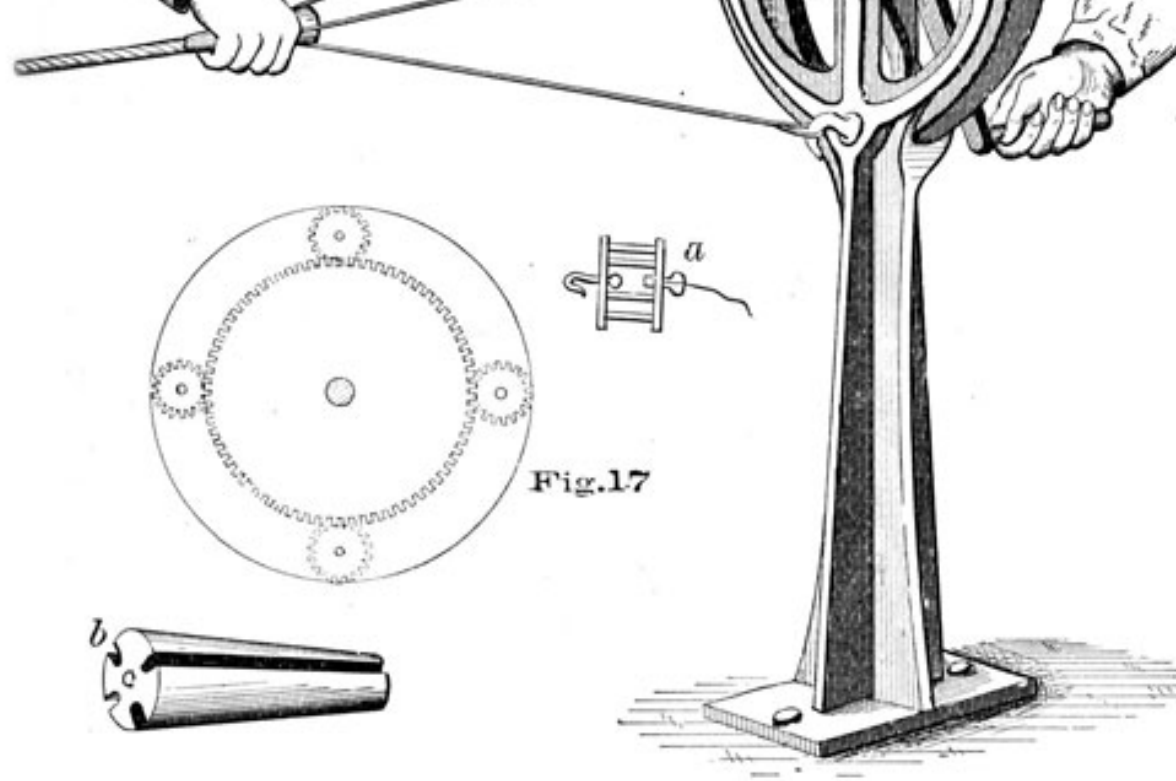


Fig.16



Fig.18





less liable to *kinks* and *grinds* when new, and is allowed, in the navy, for reeving off lower and topsail braces.

Shroud-laid. Rope, Fig. 16, Plate 7, is formed by adding another strand to the plain-laid rope. But the four spirals of strands leave a hollow in the centre, which, if unfilled, would, on the application of strain, permit the strands to sink in, and detract greatly from the rope's strength, by an unequal distribution of strain. The four strands are, therefore, laid up around a *heart*, a small rope, made soft and elastic, and about one-third the size of the strands.

Experiments show that four-stranded rope, when under 5 inches, is weaker than three-stranded of the same size; but from 5 to 8 inches, the difference in strength of the two kinds is trifling, while all above 8 inches is considered to be equal to plain-laid when the rope is well made.

Four-stranded rope is now but little used except for lifts, preventer-parrels, Jacob's ladders and rigging

laniards.

Tapered Rope is used where much strain is brought on only one end. That part which bears the strain is full-sized, tapering off to the hauling part, which is light and pliable. Fore and main tacks and sheets are made of tapered rope.

Twice-laid Rope is made from second-hand yarns. This rope may be readily known by the different shades of color of the yarns, but it is often difficult to determine, by mere inspection, whether it is relaid from what was good rope, and, consequently, still good, or made up from junk or condemned rigging, and worthless. Twice-laid rope is only met with on board ship when necessity has compelled its purchase on foreign stations.

Manilla Rope seems to be better adapted to certain purposes on board ship than hemp, being more pliable, buoyant, causing less friction, and not so easily affected by moisture. It is used for hawsers, low-lines, and for light-running rigging and gun-tackle falls. Manilla is now less used in the navy than formerly. The Book of Allowances states that the cheap first cost of Manilla as compared with hemp is more than compensated by the greater market value of the hemp when worn-out. This statement is not correct if applied to the current relative values of hemp and Manilla junk in this country.

Hide Rope is made of strips cut by machinery from green hides. Formerly used for topsail tyes, and for tailing on to such ropes as are exposed to much chafe in some particular part, as topsail sheets, etc., it is now allowed only for wheel ropes. Its strength is about one-third that of hemp.

Hide rope requires care to keep it in good order, and should not be exposed to the weather unnecessarily. It should be given a lick of thin tar (Swedish preferred)

as often as may be necessary, usually about twice a year.

Avoid serving the splices of hide rope. When spare wheel ropes are stowed away they should be well oiled and headed up in a barrel to preserve them from rats and mice.

One set of wheel-ropes is now supplied of flexible iron wire-rope.

Bolt Rope is the name applied to rope used for roping sails. It is made of the best hemp and finest yarns, and is the most superior kind of cordage.

Wire Rope for general use in the navy is made from one quarter to seven inches, inclusive, in circumference, those being the maximum and minimum sizes likely to be needed.

Each strand has a hemp heart, and the rope itself has a heart usually of the same material; this adds greatly to its pliability.

When first introduced, it was thought that great difficulty would be found in manipulating wire rigging, but our best riggers cut, fit and splice it as readily as they do hemp rigging.

In its less bulk and cost, wire rope has decided advantages over hemp for the standing rigging of ships, and now all vessels of the navy are provided with standing rigging of wire.

Besides the great advantage that wire rigging possesses of not being affected by the heat and sparks from the smokestack, its durability is at least three or four times that of common rope, and, when once completely *set*, does not require further pulling up.

Wire rope may be used for strapping blocks, and will be found neat and serviceable.

In Appendix A will be found a table of comparative dimensions of chain cables, hemp, iron and steel rope, with breaking strains and weights per fathom.

Small Stuff is the general term applied to small rope. It is particularized by the number of threads or yarns which it contains, and is further known either as *ratline stuff* or *seizing stuff*.

Ratline Stuff is three-stranded, right-handed small stuff of 24, 21, 18, 15 or 12 threads. It is measured by the fathom.

Seizing Stuff, Is of 9, 6, 4 or 2 threads, and is measured by the pound. While all varieties of small stuff may be spoken of as "24, 18, 9, &c., thread stuff," the smaller varieties have also special names, according to their number of threads and the manner of laying up. We have:

Hambroline, two-stranded, right-handed, and

Roundline, three-stranded, right-handed. Both of

these are made of fine back or left-handed yarns, so that the stuff itself is right-handed.

Marline, two-stranded, left-handed.

Housline, three-stranded, left-handed. Both of these are made of finer dressed hemp, and have altogether a neater, cleaner and smoother appearance than spun-yarn.

Spun-Yarn is also left-handed, and of two, three or four strands. Spun-yarn is always in great demand aboard ship, being used for seizings, service, and a great variety of purposes. In its manufacture, "*long tow*," as it is termed, or the tow of the first hackling, is hackled again, and laid up loosely, left-handed, and to keep it from opening is well tarred and rubbed down.

For fine seizings and service, hambroline and roundline (right-handed), or marline and housline (left-handed) are the kinds of small stuff selected. For ordinary purposes, spun-yarn is used.

Nettles, used for hammock clews, and where very neat stops are required, are made by laying up two or three yarns in a taut twist with the thumb and fingers, and then rubbing it down smooth.

Foxes, used for temporary seizings, making mats, sennit, gaskets, reefing beackets, boat gripes, bending studding sails, &c., are made of two or more yarns, as required, laid up by twisting by hand, and then well rubbed down with a piece of tarred parcelling.

A Spanish Fox is a single yarn twisted up tightly in a direction contrary to its natural lay-that is, left-handed, and rubbed smooth. It makes a neat seizing, and is used for the end seizings of light standing rigging, and for small seizings generally.

Rumbowline is the name sometimes applied to coarse, soft rope, made from outside yarns, to be used for temporary lashings, &c.

Rogue's Yarn is a single untarred thread, sometimes placed in the centre of the rope, or in the centre of each strand, denoting government manufacture.

Junk is supplied for the purpose of working up into various uses-such as for swabs, spun-yarn, nettle-stuff, lacings, seizings, earings, gaskets, &c.-of all of which the supply, in proper kind, is generally inadequate. Good junk is got out of such material as condemned hawsers-they having been necessarily made of the best stuff, and condemned before being much injured. Old rigging makes bad junk, not being condemned generally until much worn.

Of the worst junk, swabs and spun-yarn should be made; of the best, nettle and seizing-stuff, lacings, earings, &c.

Large junk, such as lengths of towlines, should be unlaid

before being put below, that it may admit of being snugly stowed.

Shakings are odds and ends of yarns and small ropes, such as are found in the sweepings of the deck after work. They are collected, put in a bag kept for the purpose, and at certain times served out to the watch to be picked into *Oakum*, a good supply of which should always be on hand for any calking that may be required, for stuffing jackasses, boat's fenders, &c.

Use of the Ropermaker's Winch, Fig. 18, Plate 7. A ship's winch, which will make very fair 2-inch rope, is about 15 inches in diameter. In the frame, which is double, are placed five hooks-the three upper ones for general use, the fourth for four-stranded rope, and the centre one for hardening up large rope after it has been laid up by the upper ones (the latter not being sufficiently strong for the purpose). The shanks of the hooks, between the two parts of the frame, are inserted in cogged barrels, which are turned by the wheel, one revolution of which gives nine to the hooks-any one of which can be thrown out of gear by hauling it back close to the after part of the frame.

A *loper* is a swivel hook, Fig. 17 (a), which, by revolving freely, allows the strands to twine up together, by the twist put in them as the top is withdrawn.

The *top*, Fig. 17 (b), is a conical piece of wood, scored on the outside for the reception of the strands. Its use is to keep the strands separate between it and the winch, and to regulate the amount of twist in the rope behind it, by being moved along either slowly or rapidly. When four-stranded rope is required, a hole is bored through the centre, as a lead for the heart.

A length of junk being brought on deck, you proceed to unlay it by attaching the strands to separate hooks, and the looper to the other end-one hand holding back on it, and then heaving back-two hands following the rope down to separate the ends.

Spun-Yarn is made by hooking all the yarns that compose it (according to the size required) upon one hook. You then heave round, the reverse way to the lay of the yarns (which in ordinary rope are all right-handed) until there is plenty of back turn in them, holding on the ends by hand; then rub down and make it up.

In rubbing down, a boy puts the end of a strand over his shoulder, and walks away with it, another hand holding on the rubber (which is the end of the strand doubled up loose) round the stuff they are laying up.

As many lengths of spun-yarn can, of course, be made at once as there are hooks on the winch.

Nettle-Stuff. Hitch the yarns to separate hooks; let a couple of hands then take hold of them, and commencing close to the winch, walk back while it is hove round the

reverse way; the yarns are thus hove up the contrary way to what they were originally, to soften them; for when drawn out of rope, they are usually hard and angular; and would not lie square, or bear an equal strain, if laid up in that condition. When thus relaid, the ends are knotted together, the loper hooked on one hand holding on to it, the top put in, the winch hove round the same way as at first, and the top moved along towards the winch. When up to it, the top is taken out, the yarns unhooked, and hitched to a single hook, then the winch hove round the opposite way to what you have just been heaving it, to harden the stuff up; rub down and make up.

Thus, the yarn will be left-handed, and the nettle-stuff right-handed; for, though the winch is hove round the same way with both, the twist in the yarns causes them to unite abaft the top with the lay of contrary denomination, and the revolutions of the loper prevent the turn coming out again.

Six (or nine) Thread Stuff: Put two (or three) yarns on three separate hooks; hold on the end by hand, keeping each of the three lengths separate, and heave round a reverse turn, as with spun-yarn. When sufficiently hove up, knot the ends together, hook on the loper, put in the top, and proceed as with nettle-stuff.

Fig. 18 gives a general idea of the winch, in operation.

General Remarks on Rope. The strength of a rope-yarn of medium size is equal to 100 lbs., but the measure of strength of a given rope is not, as might naturally be supposed, 100 lbs. multiplied by the number of yarns contained in the rope. The twist given to the yarn, after certain limits, diminishes its strength, as already stated, and with the best machinery it is scarcely possible that each yarn of the rope should bear its proper proportion of strain. The difference in the average strength of a yarn differs with the size of the rope. Thus, in a 12-inch rope, the average strength of each yarn is equal to 76 lbs., whereas, in a rope of half an inch, it is 104 lbs.

Experiment has shown that by applying a constant, or even frequent, strain equal to half its strength, the rope will eventually break. This seems to be particularly the case with cable-laid rope, which is the weakest of all.

It has been ascertained that a good selvagee, carefully made with the same number and description of yarns, as the common three-stranded plain-laid rope, possesses about the same degree of strength.

It has been shown by experiment, that where a span is so placed as to form an angle less than 30 degrees, the strength of the two parts of the rope or chain of which it is composed, is less than the strength which one such part would have if placed in a direct line with the strain.

the direction pursued by the hands of a watch; the left-handed ropes, against the sun. An exception to this rule is in the hemp cables and hawsers, which are left-handed and are coiled away with the sun.

In taking out new rigging from a coil, the end should be passed through the coil and coiled down against its lay to get the turns out.

Avoid covering hemp rope with leather, especially green hide, unless good and well-tarred parcelling be interposed.

Rope contracts very considerably by wetting it. Advantage may be, and often is, taken of this, by wetting lashings, which are required to be very taut and solid, and are not permanent, as the lashing of a garland on a lower mast for taking it in or getting it out. For the same reason in rainy weather, braces, halliards, sheets, clew-lines, and other rigging requiring it, should be slacked up to save an unnecessary strain on the rope, and avoid the risk of springing a yard or carrying something away.

Running rigging has nothing to protect it from the effects of the weather, excepting, in hemp, the tar taken up in the process of manufacture, and after being wet the air should be allowed to circulate through it freely. Rope should never be stowed away until thoroughly dry.

Running rigging, when not in actual use, should be kept neatly coiled down near the pin to which it belays, taking care always to capsize the coil that the running part may be on top, so that it may run clear. In port, during good weather, the rigging may be coiled down in flemish coils, that is, perfectly flat, as soon as the decks are dry enough in the morning, and left so until the decks are cleared up at seven bells in the afternoon, when the ends should be run out, the rope coiled down snugly and triced up in readiness for washing decks in the morning.

When scrubbing clothes or hammocks, soap at times unavoidably gets on the rigging: it should be carefully washed off before the decks are dry.

One rope may be rove by another by putting the two ends together, and *worming* three yarns or pieces of spun-yarn in the lay for three or four inches on each side, and clove-hitching the ends around the rope, or opening the strands and laying them in. This is always done when reeving new braces by old ones, and

with running rigging generally.

To Find the Breaking Strain of Government Rope:

Untarred Hemp: Multiply the square of circumference in inches by 1371.4 = strength in pounds.

Tarred Hemp: Use in above formula 1044.9 as the multiplier.

Manilla Rope: Use 783.7 as the multiplier.

29

Iron-wire Rope: Weight in pounds per fathom x by 4480 = strength in pounds, but if

Steel-wire Rope, use 7098 as the multiplier. Or by the

Practical Rule for ascertaining the Strength of Rope. The square of half the circumference gives the breaking strain of the weakest plain-laid rope in tons, and is therefore a safe rule.

Thus, by the table, the breaking strain of a 6-inch rope is 10 tons, and by the rule $(6/2)^2=9$ tons.

The breaking strain of a 10-inch rope is, by the table, 28 tons, and by the rule $(10/2)^2=25$ tons.

No cordage should be subjected to a strain above one-third of its estimated strength.

For ascertaining the Weight of Rope. Three-strand, plain-laid, 25-thread yarn, tarred. Multiply the square of the circumference by the length in fathoms, and divide by 4.24 for the weight in lbs.

Ex. 2-inch rope, 113 fathoms. $(2^2 \times 113)/4.24 = 106$ lbs. - actual weight, 105 lbs.

The divisor for hempen cables is 4.79.

A Practical Rule for determining the relative Strength of Chain and Rope. Consider the proportionate strength of chain and rope to be ten to one-using the diameter of the chain and the circumference of the rope. Half-inch chain may, therefore, replace five-inch rope.

The absolute strength of chain, at the *breaking point*, may be found by dividing the square of the diameter in eighths, by 2.4 for round link crane chain, and by 2.7 for chain cable.

To find the Weight a Rope will lift when rove as a Tackle: Multiply the weight the rope will sustain by the number of parts at the movable block, and subtract one-fourth of product for resistance.

To find the size of Rope when rove as a Tackle to Lift a given Weight: Divide the weight to be raised by the number of parts at the movable block to get the strain on a single part, add one-third of this for the increased strain due to friction, and reeve the rope of the corresponding strength.

To find what Number of parts of a parts of a small Rope are equal to a large Rope: Divide the square of the circumference of the larger rope by the square of the circumference of the smaller, and the result will be the number of parts of the smaller equal to one part of the larger.

To find the Proportionate Strength of Wire and Hemp Ropes: Multiply the square of the circumference of a hemp rope by .223 for

iron wire, and by .12 for steel wire, and the square root of product will be the circumference of a wire rope of corresponding strength.

The wire-rope referred to has a *hemp* heart.

By multiplying the square of the circumference of a wire rope by 4.5 for iron wire and 8.4 for steel wire and extracting the square root of the product, the circumference of a hemp rope of corresponding strength may be obtained.

Plate 8.

Fig.19

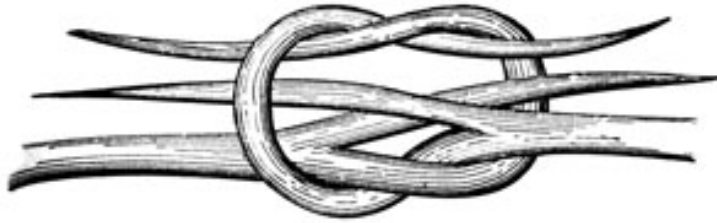


Fig.20

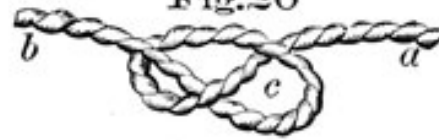


Fig.21

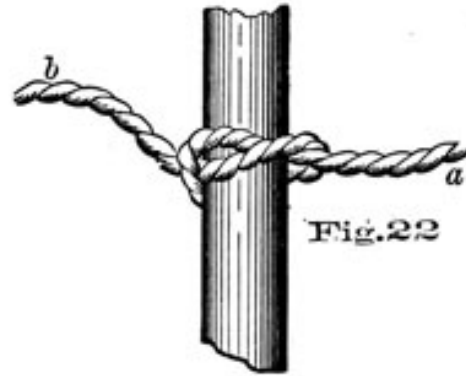


Fig.22

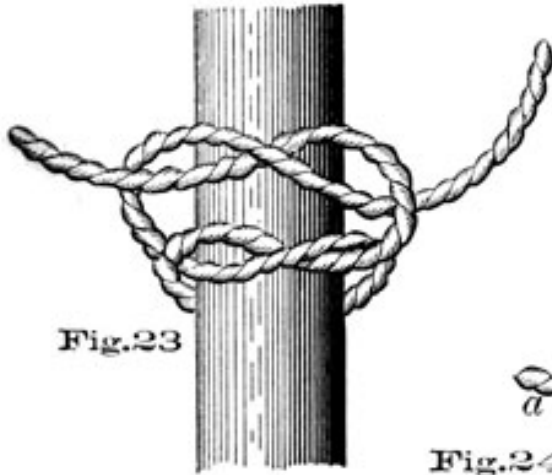


Fig.23



Fig.24

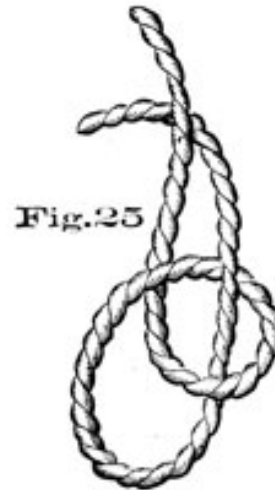
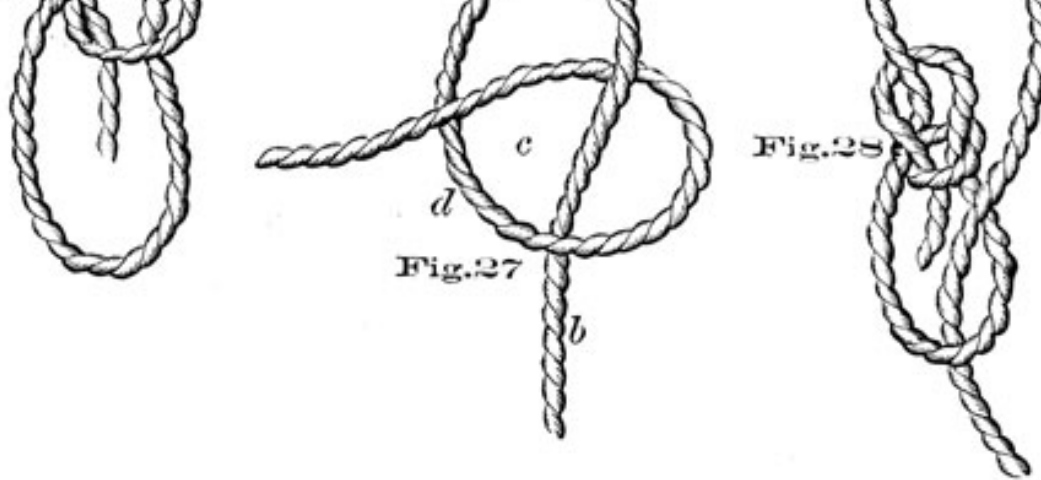


Fig.25



Fig.26





CHAPTER IV.

KNOTTING, SPLICING, ETC.

To Knot a Rope Yarn, Fig 19, Plate 8. Split in halves the two ends of a rope-yarn, scrape them down with a knife, crotch and tie the two opposite ends; jam the tie and trim off the ends.

An Over-hand Knot, Fig. 20, Plate 8. Pass the end of a rope (b) over the standing part (a) and through the bight above (c).

Figure-of-Eight Knot, Fig. 21, Plate 8. Take the end of a rope (a) round the standing part (b), under its own part (d), and through the bight (c).

A Reef Knot, Fig. 23, Plate 8. Make an overhand knot, as before directed, Fig. 22, round a yard or spar; bring the end (a), being the next towards you, over to the left, and (b) to the right, take (a) round (b), draw them taut, and it is done, Fig. 23. This knot is used in tying reef points and small stuff generally. Observe to bring the end out next its own part, otherwise it will be a *Granny's Knot*, which jams and is difficult to cast off.

A Bow-Line Knot, Fig. 26, Plate 8. Take the end of the rope (a), Fig. 24, in the right hand, and the standing part (b) in the left, laying the end over the standing part; with the left hand turn a bight of the *standing* part over it, Fig. 25; lead the end round the standing part, through the bight again, and it will appear like Fig. 26. The bight turned in the standing part is often called a *Cuckold's Neck*.

A Running Bow-Line Knot, Fig. 28, Plate 8. Take the end of a rope, Fig. 27, round the standing part (b) and through the bight (c); make the single bow-line knot upon the part (d), and it is done.

A Bow-Line Knot upon the Bight of a Rope, Fig. 30, Plate 9. Take the bight (a) in one hand, Fig. 29, and the standing parts (b) in the other; throw a kink or Cuckold's Neck over the bight (a) with the standing parts, the same as for the single knot; take the bight (a) over the large bights (c, c), bringing it up again: it will then be complete, Fig. 30. The best way to sling a man by a bow-line is to shorten up one of the lower bights, using the lower part as a seat and putting the arms through the part next above.

A Prolonge Knot, Fig. 31, Plate 9.

A Bow-line Knot, formed *with* a bight to hook

into, as in Fig. 218, Plate 29, is used for heavy pulls, on the ends of rigging luffs, by riggers. Fig. 79, Plate 14, shows an ordinary bow-line knot formed over a ring-bolt to make a temporary stopper. Shove the bight through the ring-bolt, take a half hitch with the short end over the bight, then pass the short end through the bight. A handy knot when you wish to use a short end of a long coil.

A Wall Knot. Unlay the end of a rope, Fig. 32, Plate 9, and with the strand (1) form a bight, holding it down on the side of the rope at (2); pass the end of the next (3) round the strand (1); the end of the strand (4) round the strand (3) and through the bight which was made at first by the strand (1); haul them rather taut, and the knot will then appear like Fig. 33.

To **Crown** this knot, Fig. 35, Plate 9. Lay one of the ends over the top of the knot, Fig. 34, which call the first (a); lay the second (b) over it, and the third (c) over (b), and through the bight of (a); haul them taut, and the knot with the crown will appear like Fig. 35, which is drawn open, in order to render it more clear. This is called a *Single Wall*, and *Single Crown*.

To **Double-Wall** this knot, Fig. 36, Plate 10. Take one of the ends of the single crown, suppose the end (b), bring it underneath the part of the first walling next to it, and push it up through the same bight (d); perform this operation with the other strands, pushing them up through two bights, and the knot will appear like Fig. 36, having a *Double Wall* and *Single Crown*.

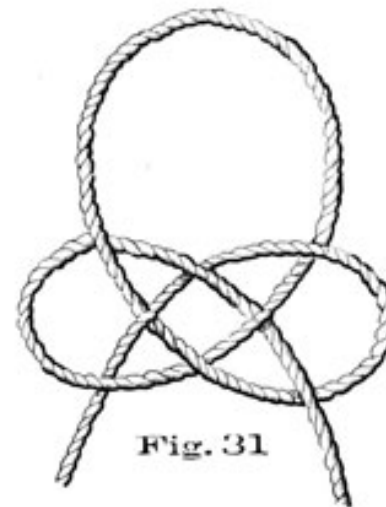
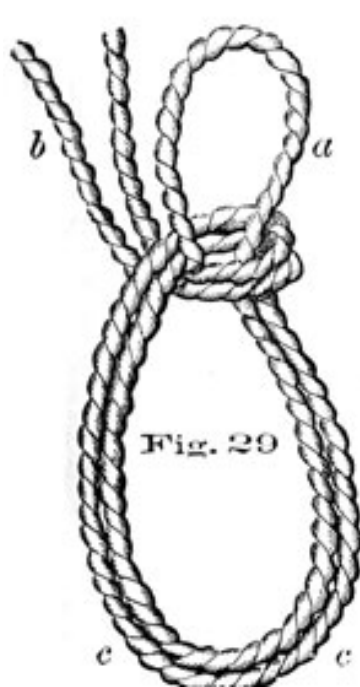
To **Double-Crown** the same knot, Fig. 37, Plate 10. Lay the strands by the sides of those in the single

crown, pushing them through the same bights in the *single* crown, and down through the double walling; it will then be like Fig. 37, viz. *single* walled, *single* crowned, *double* walled, and *double* crowned. The first walling must always be made *against* the lay of the rope: the parts will then lie fair for the double crown. The ends are scraped down, tapered, marled, and served with spun yarn. This knot is often used for the ends of man-ropes, and hence frequently called a *Man-rope Knot*.

Matthew Walker's Knot, Fig. 39, Plate 10. This knot is made by separating the strands of a rope, Fig. 38, taking the end (1) round the rope, and through its own bight, the end (2) underneath through the bight of the first, and through its own bight, and the end (3) underneath, through the bights of the strands (1 and 2), and through its own bight. Haul them taut, and they form the knot, Fig. 39. The ends are cut off. This is a handsome knot for the end of a laniard, and is generally used for that purpose.

A Single Matthew Walker. With strands (1 and 2) form a Wall knot, omitting strand (3); then with strand (3) dip down, round all parts, and come out next its

Plate 9



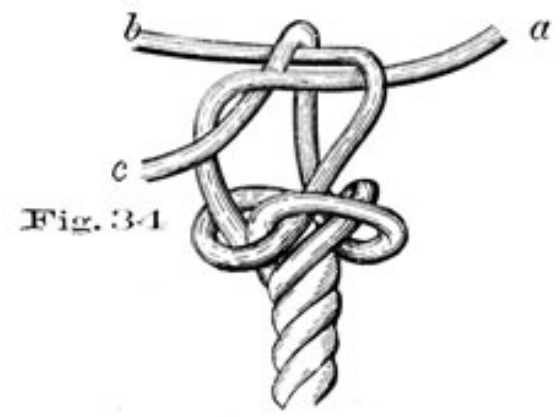
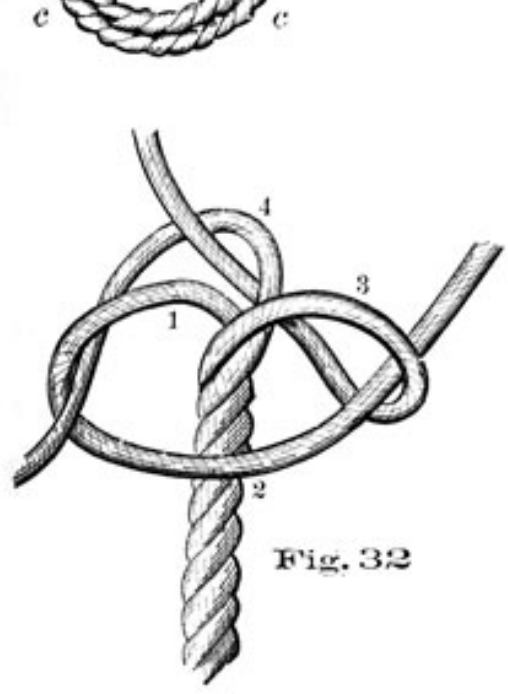


Plate 10

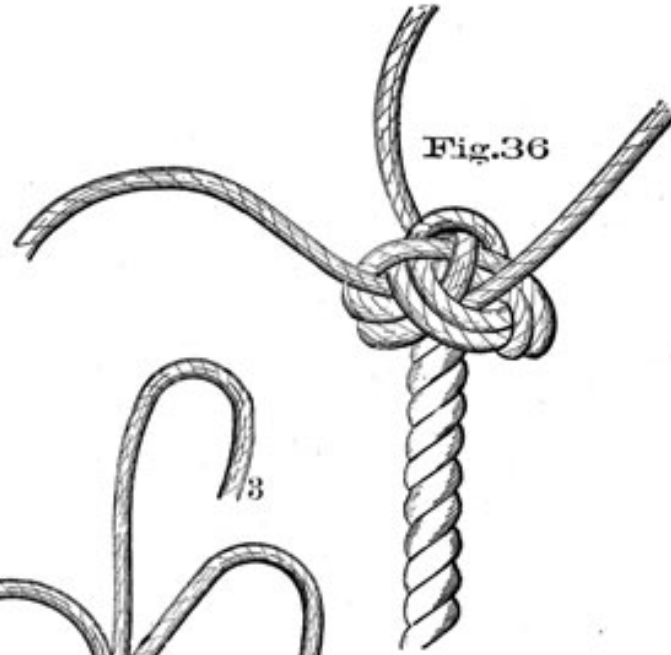


Fig. 36



Fig. 37

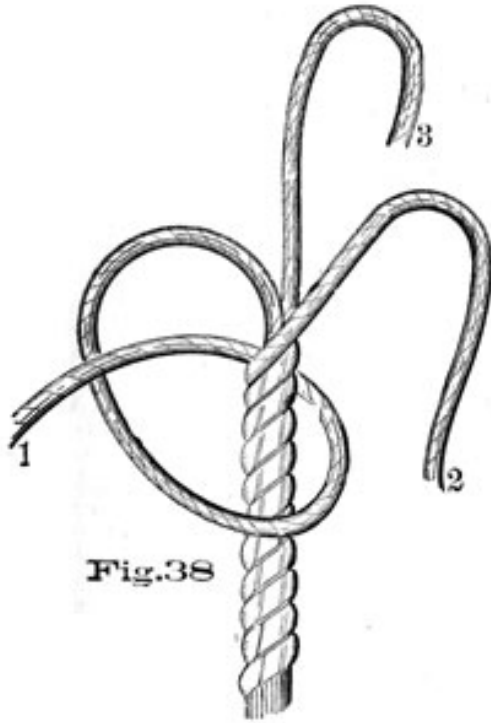
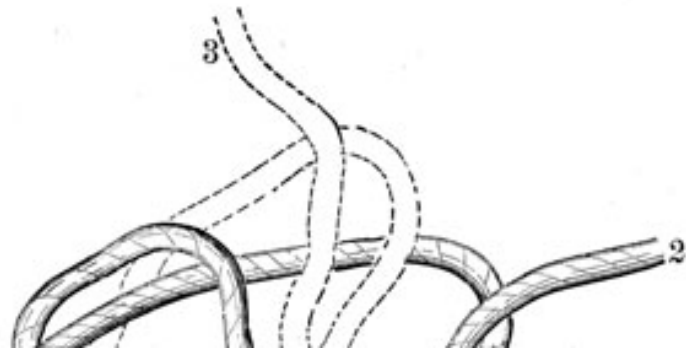


Fig. 38



Fig. 39



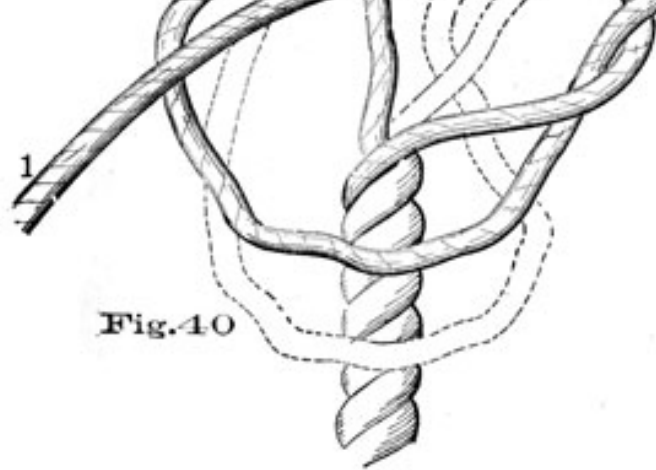


Fig. 40

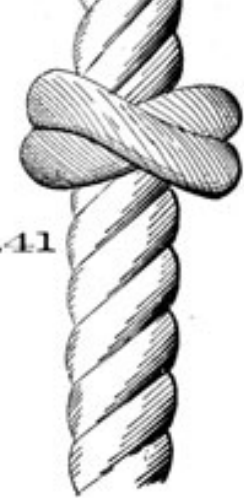


Fig. 41

Plate II

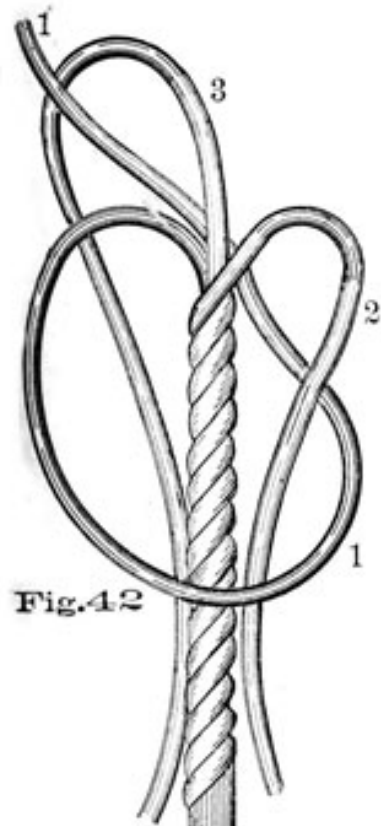


Fig. 42



Fig. 44

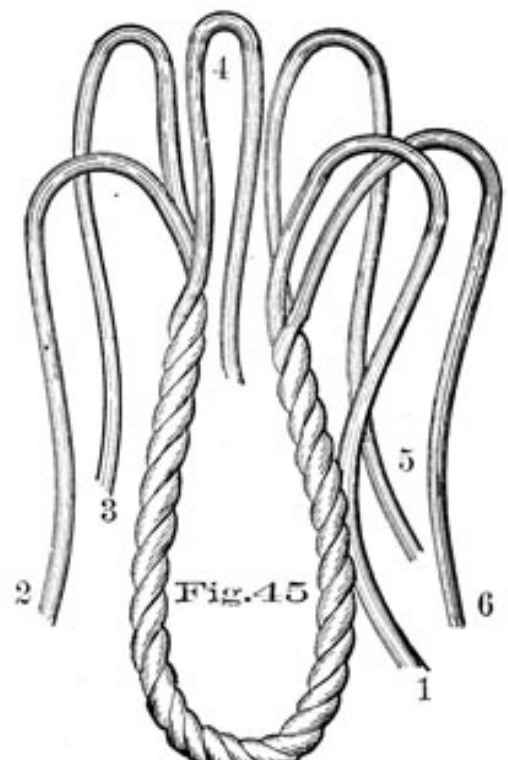


Fig. 45



Fig.43

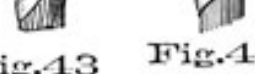


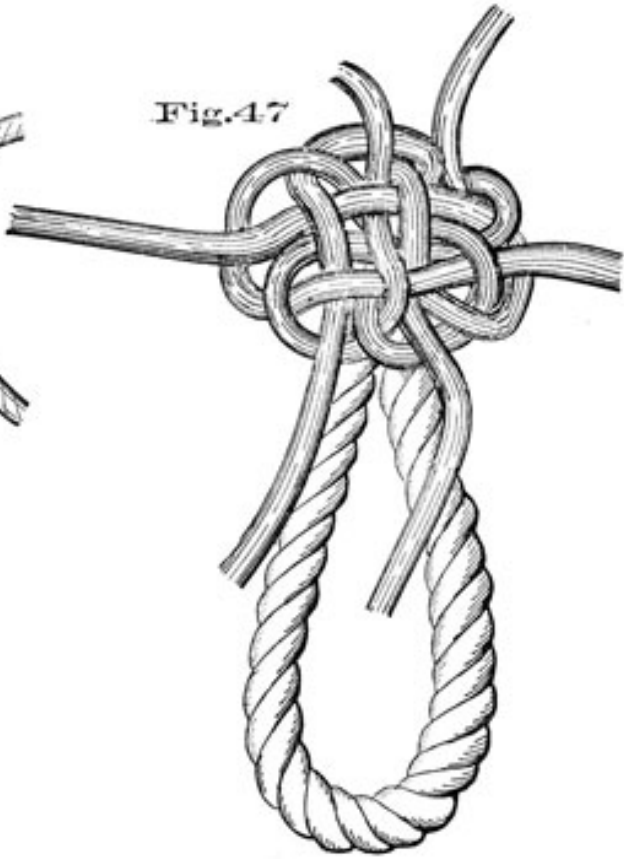
Fig.44



Fig.46



Fig.47



own part, Fig. 40. Render the parts through, jam taut, lay up and whip the end, Fig. 41. This knot is used for bucket ropes, &c. It should have a leather washer around its neck when exposed to chafe.

A Single Diamond Knot, Fig. 43, Plate 11. Unlay the end of a plain-laid rope for a considerable length, Fig. 42, and with the strands form three bights down its side, holding them fast. Put the end of strand (1) over strand (2), and through the bight of strand (3), as in the figure; then put the strand (2) over strand (3), and through the bight formed by the strand (1), and the end of (3) over (1), and through the bight of (2). Haul these taut, lay the rope up again, and the knot will appear like Fig. 43. This knot is used for the side ropes, jib guys, bell ropes, &c.

A Double Diamond Knot, for the same purpose, Fig. 44, Plate 11. With the strands opened out again, follow the lead of the single knot through *two single* bights, the ends coming out at the top of the knot, and lead the last strand through *two double* bights. Lay the rope up again as before, to where the next knot is to be made, and it will appear like Fig. 44.

A Sprit-Sail Sheet Knot, Fig. 47, Plate 11. Unlay two ends of a rope, and place the two parts which are unlayed, together, Fig. 45. Make a bight with the strand (1). Wall the *six* strands together, *against* the lay of the rope (which being *plain-laid* must be done from the right hand to the left), exactly in the same manner that the single walling was made with three; putting the second over the first, the *third* over the second, the fourth over the third, the fifth over the fourth, the sixth over the fifth, and through the bight which was made by the first; haul them rather taut, and the single walling will appear like Fig. 46; then haul taut. It must be then crowned, Fig. 47, by taking the two strands which lie most conveniently (5 and 2) across the top of the walling, passing the other strands (1, 3, 4, 6) alternately over, and under those two, hauling them taut; the crown will be exactly similar to the figure. It may be then double walled, by passing the strands (2, 1, 6, &c.) under the wallings on the left of them and through the same bights, when the ends will come up for the second crowning, which is done by following the lead of the single crown, and pushing the ends down through the walling, as before, with three strands. This knot, when double-walled, and crowned, is often used as a stopper knot, in the Merchant Service.

A Stopper for a Stranded Foot or a Leech Rope, Fig. 48, Plate 12. This is made by *double walling*, *without crowning*, a three-stranded rope, against the lay, and stopping the ends together, as in the figure. The ends, if very short, are whipped without being stopped.

A stopper knot on the end of a *deck stopper* is made as in Fig. 49, by a single crown and single wall. The ends are whipped singly and cut off. A deck stopper has a lanyard spliced around the neck of the knot, and a hook and thimble spliced in the other. When made of wire rope, a deck stopper is fitted as in Fig. 50, where an iron toggle is spliced into the end of the stopper in place of the knot.

A Shroud Knot. Unlay the ends of two ropes, Fig. 51, placing them one within the other, drawing them close as for splicing; then single-wall each set of ends—those of one rope, against the lay (i.e. from left to right if the rope be cable-laid, as in the figure), round the standing part of the other. The ends are then opened out, tapered, marled down, and served with spun-yarn. This knot is used when a shroud is either shot or carried away. Fig. 54 and Fig. 55.

A French Shroud Knot. Place the ends of two ropes as before, Fig. 51, drawing them close. Laying the ends on one side back upon their own part, single-wall the remaining ends around the bights of the other three and the standing part, and it will appear as in Fig. 52. When hauled taut, it appears as in Fig. 53. The ends are tapered, &c., as before. This knot is as secure as the other, and much neater.

HITCHES.

Hitching a Rope, Fig. 56, Plate 12, is performed thus: Pass the end of a rope (b) round the standing part; bring it up through the bight, and seize it to the standing part at (d). This is called a *Half-hitch*. Two of these, one above the other, Fig. 57, are called *Two Half-hitches* or a *Clove-hitch*. Fig. 58 represents a half-hitch around a spar; Fig. 59, Plate 13, a clove-hitch, with a ratline around a shroud.

A Timber-Hitch, Fig. 61, Plate 13. Take the end part of a rope (a) round a spar or timber-head, lead it *under* and *over* the standing part (b), pass several turns round its own part (c), and it is done, Fig. 60; when taut it appears as Fig. 61.

A Round Turn and a Half-Hitch, Fig. 62, Plate 13. Used for bending a hawser to the ring of an anchor.

A Timber and Half-Hitch, Fig. 63, Plate 13. Used for bending a line to a spar, for towing, &c.

A Blackwall Hitch, Fig: 65, Plate 13. Form a bight (c), Fig. 64. by putting the end (a) across under the standing part (b). Put this bight over the hook of a tackle, Fig. 65, letting the part (b) rest upon it, and the part (a) be

Plate 12

Fig.51

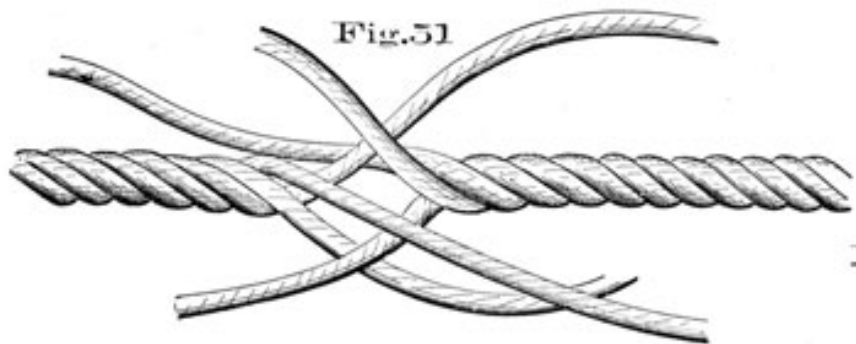


Fig.48

Fig.53



Fig.52

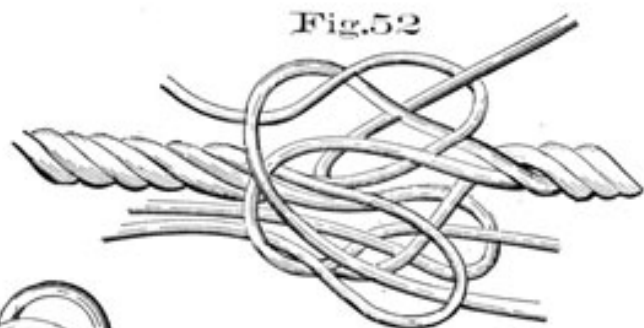


Fig.54

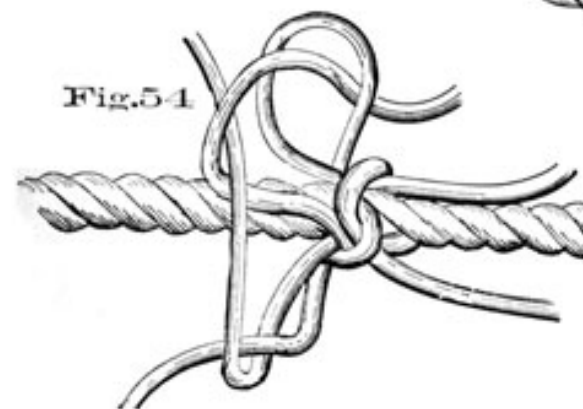


Fig.55



Fig.49

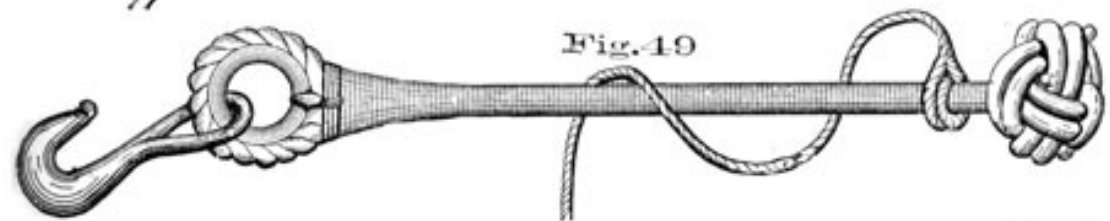


Fig.50

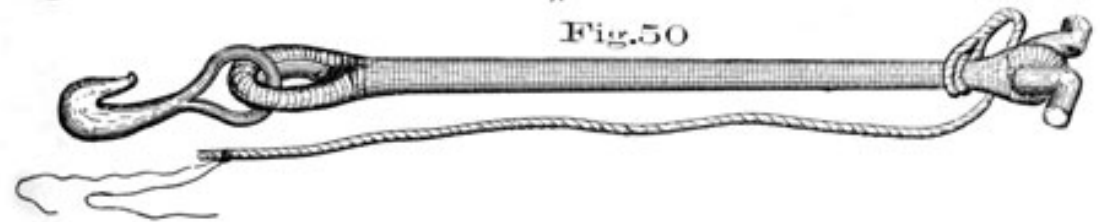




Fig. 56

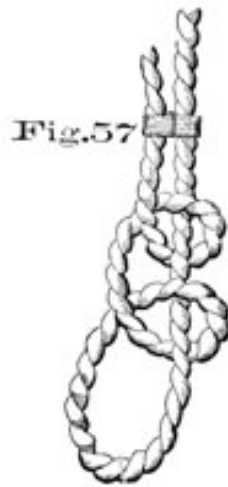


Fig. 57

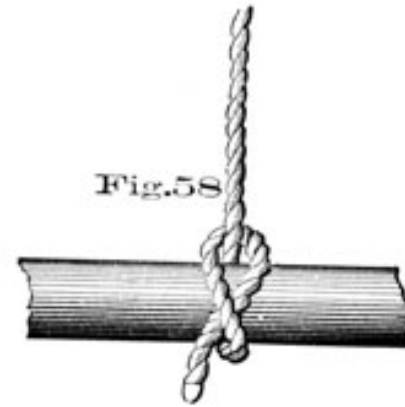


Fig. 58

Plate 13

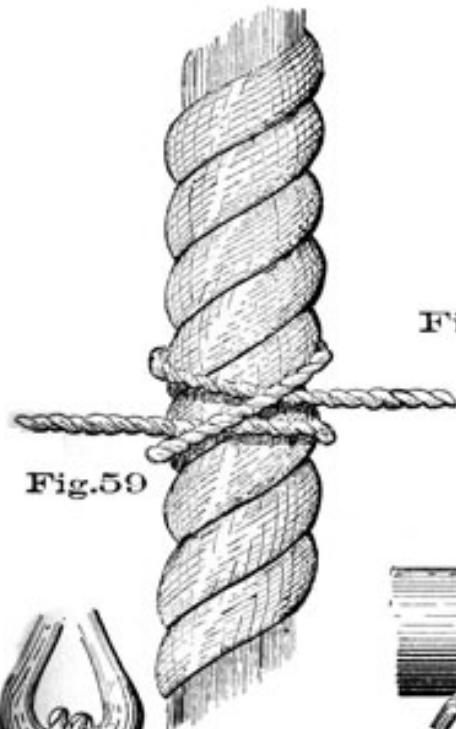


Fig. 59



Fig. 60



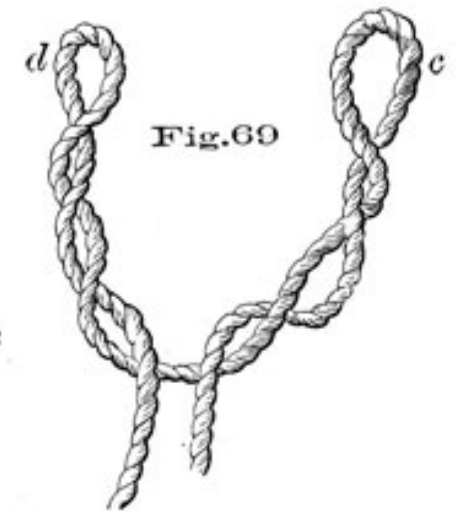
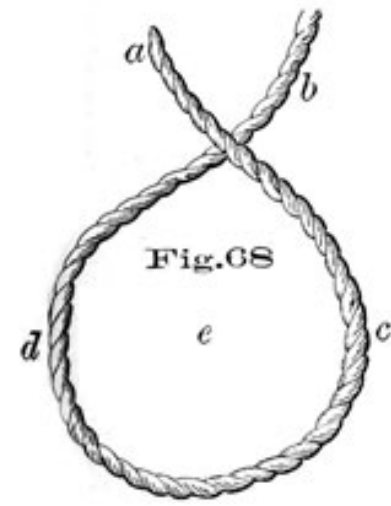
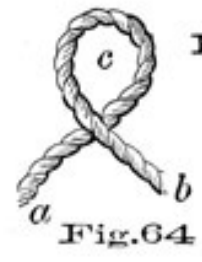
Fig. 61

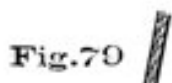
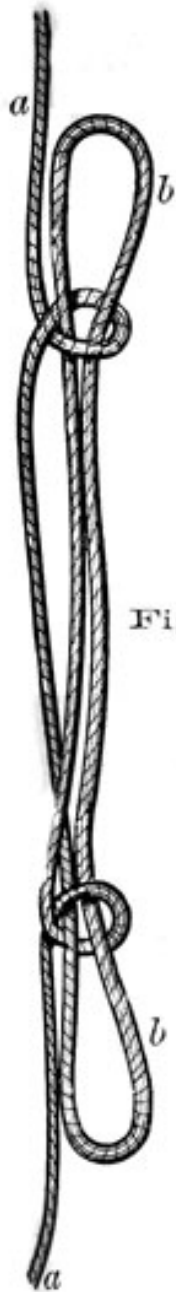


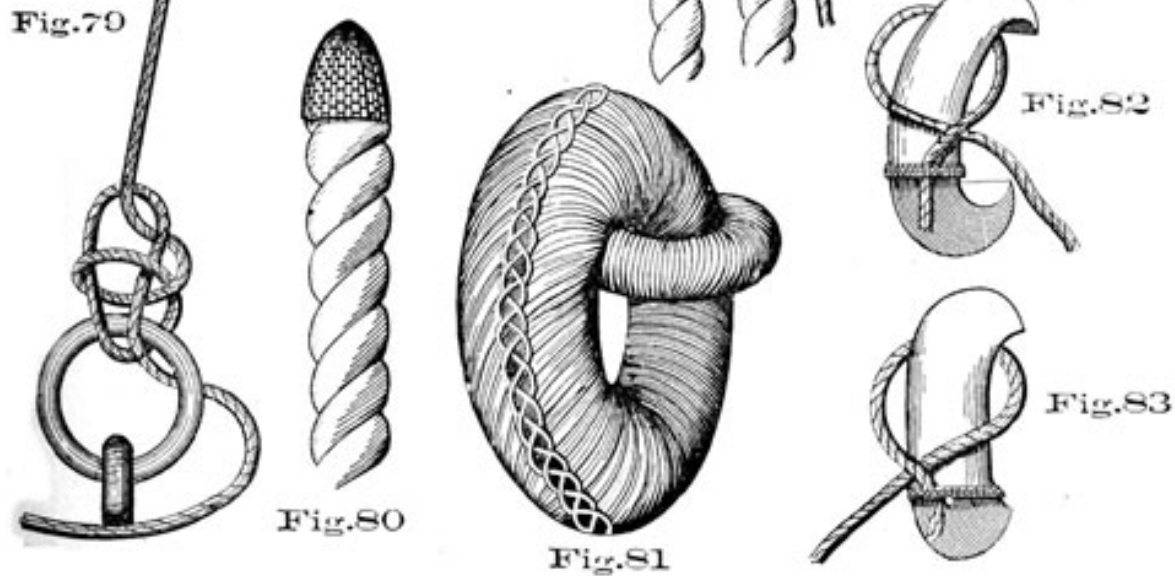
Fig. 63



Fig. 67







jammed by the standing part at the cross. This is sometimes used with a laniard, when setting up the shrouds.

A Double Black-wall Hitch, Fig. 66, Plate 13. Under a heavy strain a blackwall hitch is likely to carry away or slip, so that a Bill hitch, Fig. 67, is preferred. This is simply a marlinspike hitch [see below], with the hook thrust into the bight, the bight shoved well up on the hook. It is still better, however, to use a strap when a heavy strain is expected.

A Cat's Paw, for the same purpose, Fig. 70, Plate 13. Lay the end of a rope (a), Fig. 68, over the standing part (b), forming the bight (e), take the side of the bight (c) in the right hand, and the side (d) in the left, turn them over from you three times, and there will be a bight in each hand (c d), Fig. 69. Through these put the hook of a tackle, Fig. 70.

A Sheep Shank, Fig. 71, Plate 14. This is made for shortening a back-stay, &c.-a half-hitch is taken with the standing parts (a) round the bights (b), when it will appear like the figure.

A Rolling Hitch, Fig. 73, Plate 14. With the end of a rope (a), Fig. 72, take a half-hitch round the standing part (b), take another turn through the same bight, jamming it between the parts of the hitch; when hauled taut, it will appear like Fig. 73. The end may be taken round the standing part, or stopped to it. It is thus a tail-jigger is clapped on a rope, or fall, to augment the purchase. This is a good hitch for a

stopper, as it will not slip, and is in very general use. Fig. 74, Plate 13, shows how a stopper is passed, one of the hitches being omitted.

A Marling-Spike Hitch, Fig. 75, Plate 14. Always used in heaving on seizings. The spike is used as a pry, to heave the seizing taut.

A Harness Hitch, Fig. 76, Plate 14.

A Marling Hitch, Fig. 77, Plate 14, is used in marling down the yarns left out from a splice; for the marling put over parcelling; and for making selvagee straps, &c. It is the same as used for lashing up hammocks, Fig. 78, where seven such turns are allowed.

A Weaver's Hitch. See Sheet-Bend.

Hitching the End of a Rope. Trim the end off with a knife to the shape of a cone then, with a sail-needle and twine, stitch it around with a loop-stitch, first taking a few round turns with the twine. When finished it will resemble Fig. 80, Plate 14. All running rigging have the ends hitched to prevent unlaying, as in the figure, instead of the ordinary whipping. All the gun-tackle falls should have their ends hitched, as it is neater and better than the ordinary whipping.

To Hitch over a Ring-Bolt, Fig. 81, Plate 14. A ring-bolt is usually hitched over with either two or

three ends. With two ends,-after seizing or hitching the ends you are not working on to the ring-bolt, you commence by taking a left-handed hitch, Fig. 82, with one of the tails, keeping the cross on the centre of the bolt, which brings the end out to the right; you then double this end back over its own part to the left, bring up the other tail over this, take a hitch as with the first, double it back, bring up the first end, and so go on, taking alternate hitches with each, and bringing the end out to the right with each hitch.

With three ends, you begin by taking a left-handed hitch with the first leg, a right-handed hitch with the second, Fig. 83, then a left-handed with third, right-handed with first,-left, second,-right, third,-and so on, each hitch being passed in the opposite way to the preceding one-two ends and one end alternately lying on each side. The ends are finished off by scraping them down and either passing a whipping or working a Turk's head round them. When finished: it has the appearance shown in Fig. 81.

Kackling, Fig. 84, Plate 15. To prevent chafe, secure one end and hitch right and left handed, alternately.

BENDS.

A Sheet Bend or Single Bend, Fig. 85, Plate 15. Pass the end of a rope (a) through the bight of another rope (b), then round both parts of the rope (c d), and down through its own bight. It is sometimes called also a Becket-bend, sometimes a Weaver's Hitch.

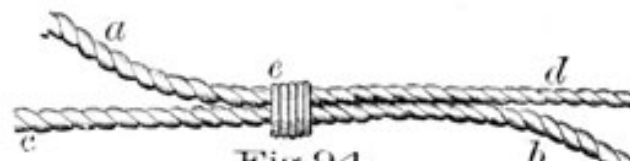
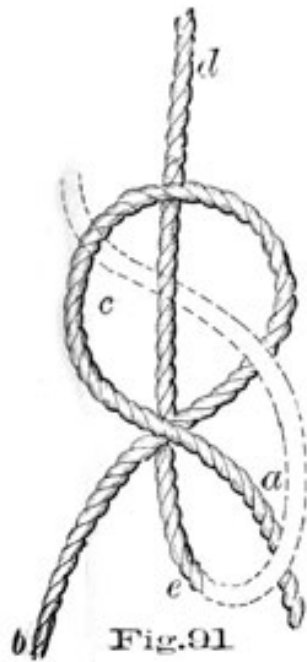
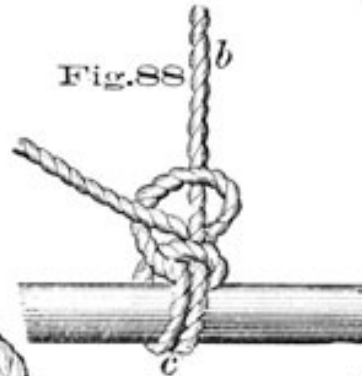
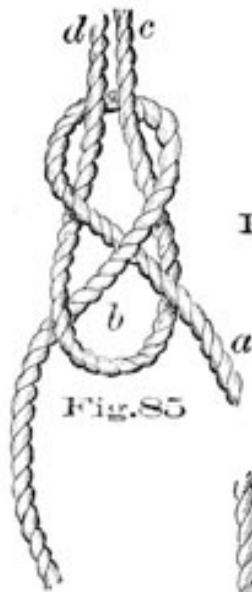
A Double Bend, Fig. 87, Plate 15, is simply taking the end around a second time. The single bend is the most common one in use. The standing part of most purchase falls are thus secured to the becket in the strap of the purchase block, as in Fig. 86.

A Fisherman's Bend, Fig. 88, Plate 15. With the end part of a rope take two turns (c) round a spar; a half-hitch round the standing part (b), and under the turns (c); then another half-hitch round the standing part (b). This is sometimes used for bending the studding-sail halliards to the yard, but more frequently for bending a hawser to the ring of an anchor, in which case the end should be stopped down with spun-yarn, Fig. 89.

The Studding Sail Halliard Bend, Fig. 90, Plate 15, is preferred to all others for bending halliards to yards, as it is safe and snug.

A Carrick Bend, Fig. 92, Plate 15. Form a bight (c), Fig. 91, by laying the end of a rope (a) across the upper surface of its standing part (b). Lay the end (e) of another rope (d) under (a and b); then following the lead of

Plate 15



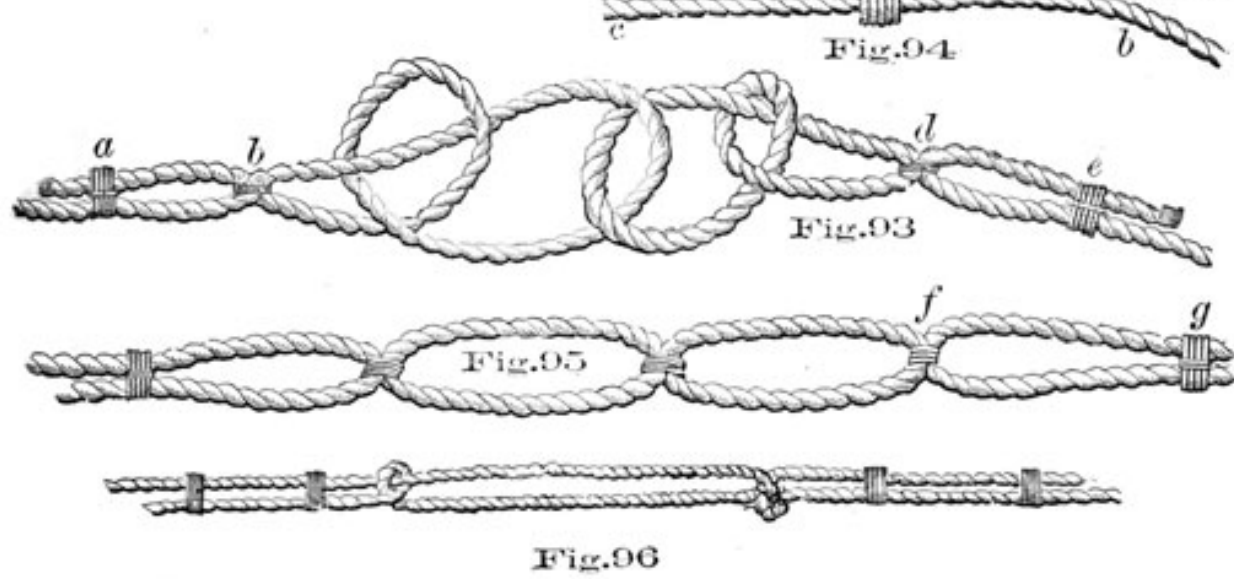


Plate 16

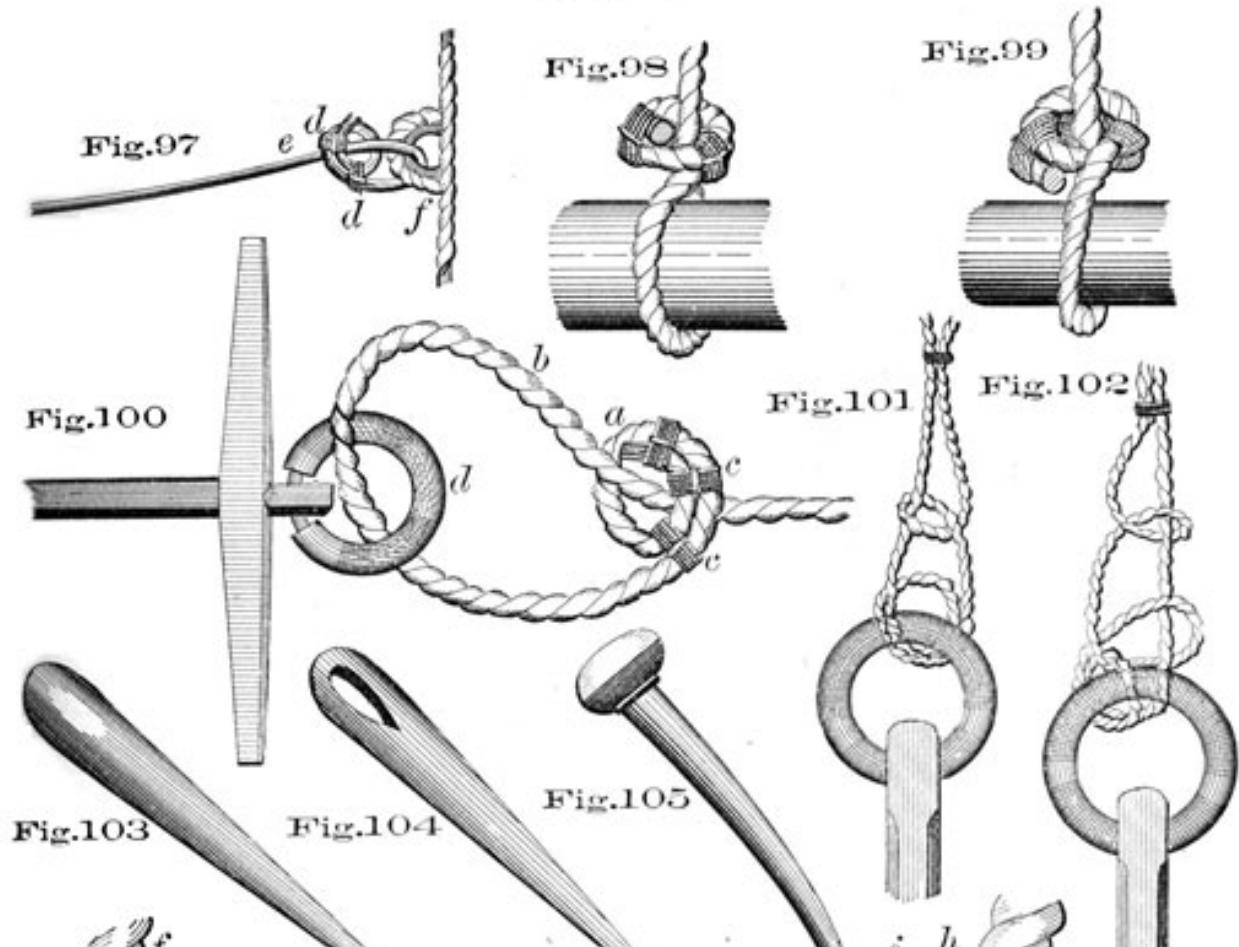




Fig. 106



Fig. 107



Fig. 108



Fig. 109



Fig. 110



Fig. 111

the dotted line, pass it *over* (a), *through* the bight, *under* (d), and up through the bight again, Fig. 92; (c) there representing the end (e) in the other figure. This bend is much used for hawsers.

Hawsers are sometimes bent together thus, Fig. 93, Plate 15; the hawser has a half-hitch cast on it, a throat seizing clapped on the standing part (b) and a *round* one at (a). Another hawser is rove through the bight of this, hitched in the same manner, and seized to the standing part (d, e).

And frequently the ends of two ropes (a, c), Fig. 94, Plate 15, are laid together; a *throat* seizing is clapped on at (e), the end (a) is turned back upon the standing part (b), and the standing part (d) brought back to (c); another throat seizing is put on each, as at (1), Fig. 95, and a round seizing near the end at (g); the same security is placed on the other side.

A Reeving Line Bend, Fig. 96, Plate 15, may also be used for small hawsers.

In any case of bending hawsers, toelines, &c., the end should be securely stopped down with spun-yarn, using racking turns if much strain is anticipated.

The best bend for a hawser to a kedge is a Fisherman's bend, Fig. 102, Plate 16, or a round turn and a couple of half-hitches, Fig. 101, with the end stopped down with spun-yarn.

CLINCHES.

The clinch is made like Fig. 97, Plate 16; the end of a bridle or leech line, for example, is rove through the cringle (f), taken round the standing part (e), forming a circle; two round seizings (d) are then clapped on. *The clinch on any rope is always made less than the cringle, &c., through which the rope is rove.*

There is an *outside* clinch, Fig. 98, Plate 16; and an *inside* clinch, Fig. 99.

To Bend a Hemp Cable, use an *inside clinch*. The end of the cable (a), Fig. 100, Plate 16, is taken over and under the bight (b), forming the shape of the clinch, which must not be larger than the ring of the anchor (d). The seizings (c), which are called the BENDS, are then clapped on and crossed.

SPLICING.

Ropes are joined together, for different purposes, by uniting their strands in particular forms, which is termed Splicing. A splice is made by opening, and separating the strands of a rope's end, and thrusting them through the others which are not unlaied. The instruments used for this

are Fids, Marling-Spikes, and Prickers. Ropes reeving through blocks are joined by a long splice, otherwise a short splice is used. *The splice is weaker than the main part of the rope by about one-eighth.*

A Fid is made according to the size of the rope it is meant to open and is tapered gradually from one end to the other, Fig. 103, Plate 16. It is commonly made of hard wood, such as Brazil, Lignum-vitae, &c., and sometimes of iron when of the latter, it has an eye in the upper end, like Fig. 104.

A Marling-Spike is an iron pin of similar mould, on the upper end of which is raised a knob, called the Head, Fig. 105, Plate 16: or it may be similar to Fig. 104. It should always have a good laniard attached, and when used aloft, either slung around a man's neck, or to the rigging.

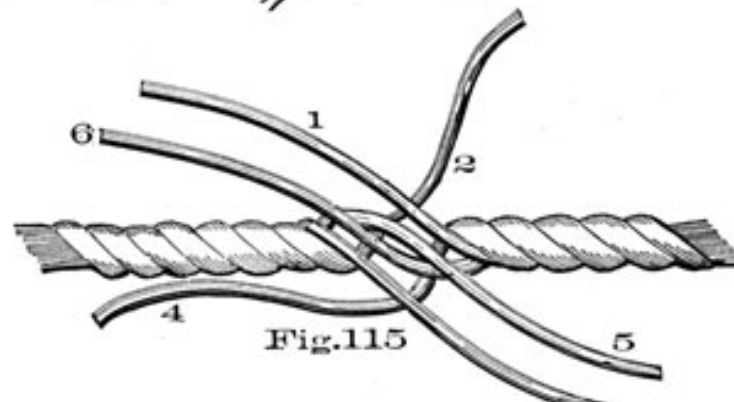
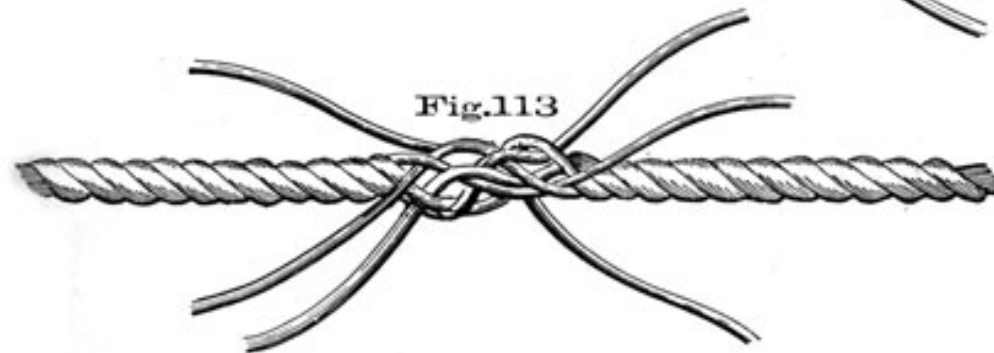
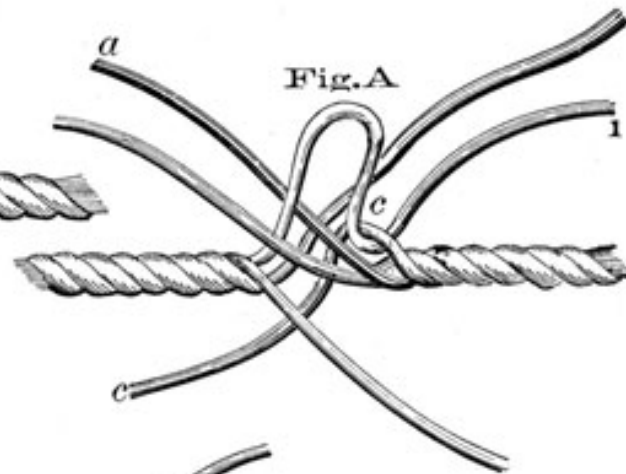
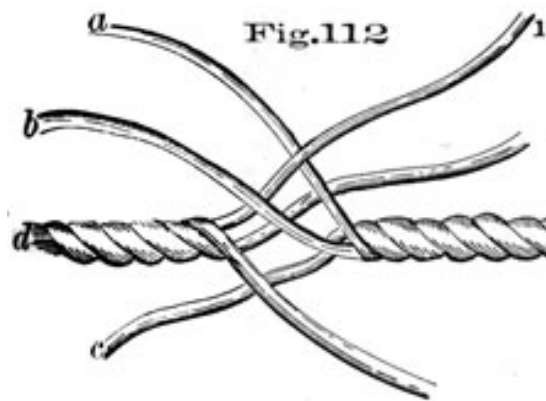
A Pricker is made of metal, hard wood, or bone, and is used for light work.

An Eye-Splice, Fig. 106, Plate 16, is made by opening the end of a rope, and laying the strands (e, f, g) at any distance upon the standing part forming the Collar or Eye (a). The end (h), Fig. 107, is pushed through the strand next to it (having previously opened it with a marling-spike); the end (i) is taken over the same strand, and through the second, Fig. 108; and the end (k) through the third, on the other side, Fig. 110. After sticking the ends once, one-half of the yarns may be cut away from the under part of the strands, and the remainder stuck again, in order to taper the splice and make it neater. In a four-stranded rope, the left-hand end lies under two strands, Fig. 111.

An Eye-Splice in a Wire Rope. Wire requires more end for splicing than hemp. Stick the whole strand once, once two-thirds, and once one-third of a strand, which will make a good taper; then set it up and stretch it well, break off the yarns close to the rope by working them backwards and forwards quickly, two or three times; then parcel and serve over with spun yarn. After sticking the ends once, clap on a good stop around all to keep the parts close together while sticking the second time, and so on.

A Short Splice. To splice the two ends of a rope together, proceed thus: Unlay the strands for a convenient length; then take an end in each hand, place them one within the other, Fig. 112, Plate 17, and draw them close. Hold the strand (a, b, c) and the end of the rope (d) fast in the left hand, or if the rope be large, stop them down with a rope-yarn; then take the middle end (1), pass it over the strand (a), and having opened it with the thumb, or a marling-spike, Fig. A, push it through under the strand (c), and haul it taut. Perform the same operation

Plate 17.



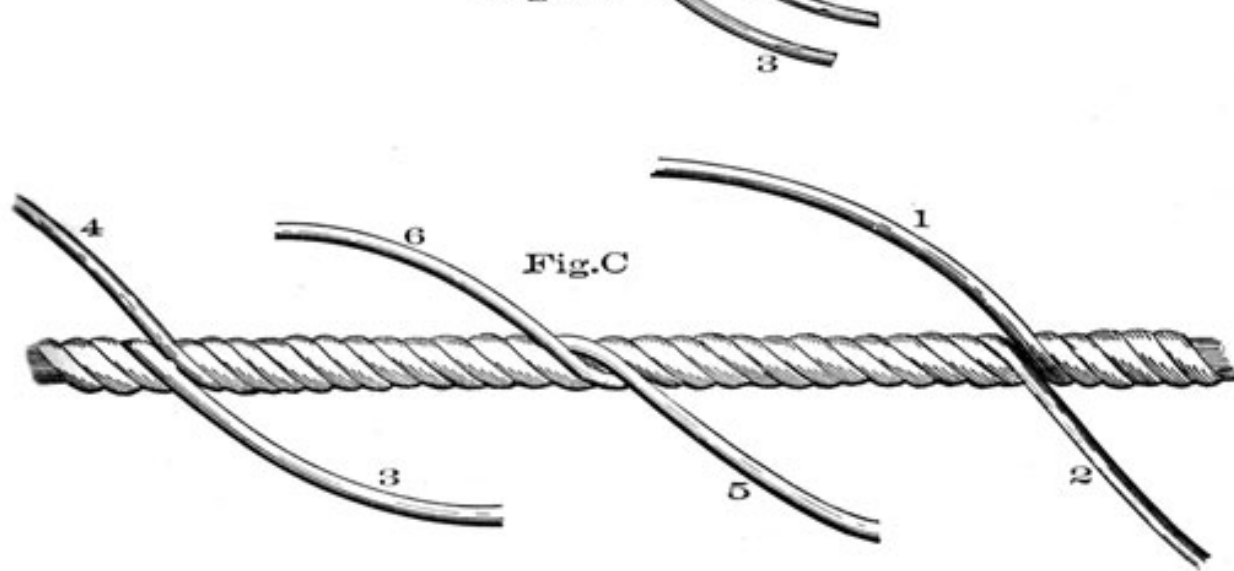
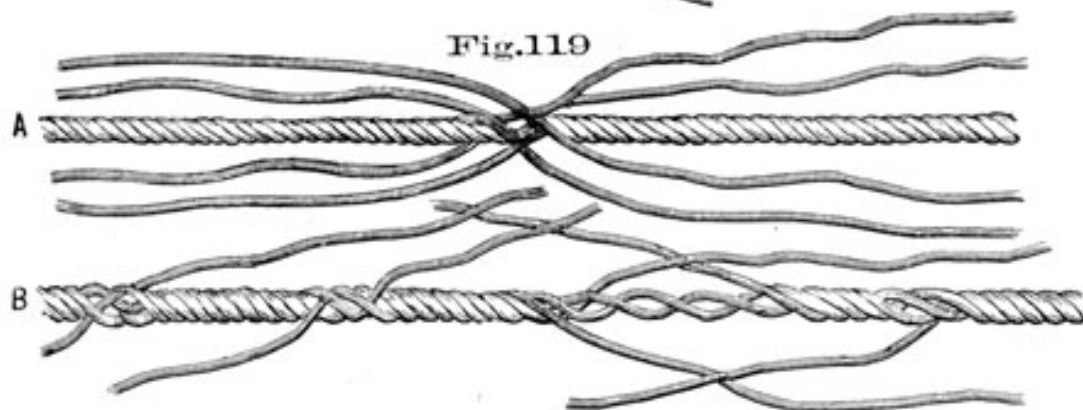
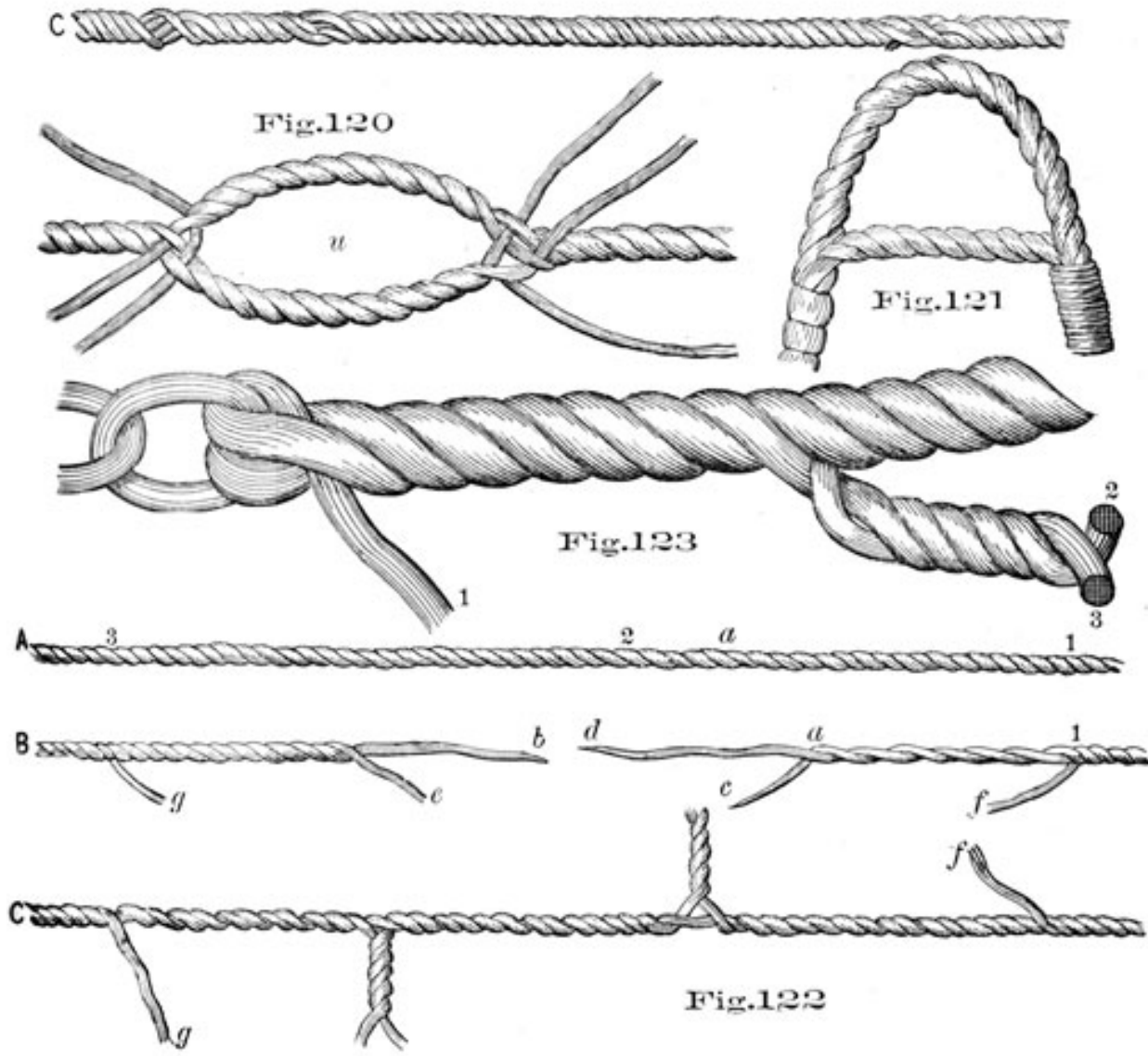


Plate 18





with the other ends, by leading them *over* the first and next to them, and *through* under the second, on both sides; the splice will then appear like Fig. 113; but in order to render it more secure, the work must be repeated; leading the ends *over* the third and through the fourth; or the ends may be untwisted, scraped down with a knife, tapered, marled, and served over with spun-yarn.

When there is to be no service used, the ends should be stuck twice each way, otherwise once and a half is sufficient. In anchor straps, and heavy straps generally, the ends *are stuck twice and not trimmed off but whipped*.

In whipping the strands they should be split and one part of each whipped, or seized, with one part of another so as to enclose a strand of the rope on each side of which they appear.

A Short Splice with a Four-Stranded Rope, Fig. 114, Plate 17.

The Long Splice, Fig. 115, Plate 17. To make this splice, unlay the ends of two ropes to a convenient distance, and place them one within the other, as for the short splice; unlay one strand for a considerable length, and fill up the intervals which *it* leaves with the opposite strand next to it. For example, the strand (1) being unlayed for a particular length, is followed in the space which it leaves by the strand (2). The strand (3) being untwisted to the left hand, is followed by the strand (4) in the same manner. The two middle strands, (5 and 6), Fig. C, are split; an over-hand knot is cast on the two opposite halves, and the ends led over the next strand and through the second, as the whole strands were in the short splice; the other two halves are cut off. When the strand (2) is laid up to the strand (1), they are divided, knotted, and the ends cut off in the same manner; and so with 3 and 4. This splice is used for lengthening a rope which reeves through a block, or sheave-hole, the shape of it being scarcely altered. After splicing, *the ends should not be trimmed off until after the splice has been subjected to a good strain*.

The following is somewhat neater. Fig. 117, Plate 18. Unlay the ends alike, and marry them together; unlay a strand on each side, and lay the strand of the Other end, that is opposite to it, up in the lay that it comes out of, making both equidistant from the centre pair of strands, which you do not touch. Twist each pair up as you have done with them, to keep them in their places, and grease the strands. For a large rope, such as the fore brace, instead of knotting the strands, merely lay them alongside each other in the score of the rope, then put the ends in once, a half, and a quarter, and *back it* with the remaining quarter of a strand to taper it off. In splicing, instead of laying a strand over one, and under the next, you *back it* by putting the strand in left-handed, under the strand you

would otherwise have laid it over, Fig. 118; which gives it an exceedingly neat and serviceable finish.

The same with four strands, Fig. 119, Plate 18.

A Cut or Bight Splice, Fig. 120, Plate 18. Cut a rope in two, and, according to the size of the collar or eye you mean to form, lay the end of one rope upon the standing part of the other, and push the ends through, between the strands, in the same manner as for the eye-splice, shown in Fig. 106, Plate 16. This forms a collar or eye (u) in the bight of the rope. The yarns left out from the strands should be scraped, marled down and served over, when neatness is required.

A Horse-Shoe Splice, or span-splice, Fig. 121, is formed by splicing the two ends of a piece of rope into each side of the bight of another rope, where an eye is to be formed. The length of rope used is one-third the length of the eye required, with twice the round of the rope on each end, in addition, for splicing.

To Long-Splice a Three and a Four-Stranded Rope Together. Unlay the ends of the two ropes to a sufficient length and crotch them; unlay one strand of the three-stranded, and fill the space with a strand of the four-stranded rope; then unlay a strand of the four and fill up from the three-stranded rope; there remains two strands of the four, and one of the three; divide the single strand by taking out one-third, with which knot to one of the remaining pair, then unlay the other one, and fill up with the remaining two-thirds; knot and stick once, stretch well, and trim off.

Another way is to work three strands as usual, and stick the fourth strand where it lies. The first plan is the better.

To Short-Splice a Three and a Four-Stranded Rope. Unlay the ends, and divide one of the three strands in half, making four strands, and proceed to splice.

Lengthening a Rope with an Additional Strand, Fig. 122, Plate 18. Cut a strand at 1, unlay until you come to 2, and cut another strand; unlay both to 3 (equal to the distance from 1 to 2, or thereabouts), and there cut the last strand separate the parts, and they will appear as in Fig. 122, B. Measure off the increased length required from 1, mark it (a), and bring the end of the left-hand piece (b) down to (a), and lay it in. The second strand, at 2, must have been cut sufficiently far from (a) to allow end enough for knotting and laying in. Twist the ends (c and b) up together ready for knotting, on finishing the splice, and

(d and e) in the same manner for the present; the splice will then have the appearance represented in Fig. 122, c. Cut a piece of rope, and unlay a strand sufficiently long to fill in the vacant lay between (f and g), and to knot with the ends (f, g); lay the strand

in, and finish off as with an ordinary long-splice, from which it will only differ in appearance by its having four breaks in the rope instead of three. In putting in the long strand, care must be taken to follow the lay along correctly, or it will not tally with the ends (f, g), with which it knots.

If it is required to give a sail more spread by inserting a cloth, the head and foot rope must be lengthened in this way. For all sizes of rope, take eight times the round for splicing, in addition to what is wanted to lengthen the rope. To lengthen two feet, cut the strands three feet apart; and the additional strand must be over nine feet long.

To Shorten a Rope in the Centre. Proceed precisely as in the previous case but, instead of separating strand (b) from 1, bringing it down to (a), *take it up* on 1 as far as you require to reduce the rope. No additional strand is used, so knot (b, f), (d, g), and (e, c); finish off the ends, and in appearance it differs in no way from the common long-splice.

To Splice a Rope around a Thimble. Whip the rope at twice and a half its circumference from the end. The length to go round the thimble should be once the round of the thimble, and once the round of the rope, from the whipping to where the first strand is to be struck. If the splice is not to be served, whip the ends of the strands, to prevent them from opening out into yarns, and stick them twice, whole strand. If to be served, after one half of each strand is put through, it is cut off, and the other half is opened out, wormed along the lay, and marled down. Parcel the thimble.

A Sailmaker's Splice is used when ropes of different sizes are to be joined neatly, and they require tapering, that the change may be gradual; as in splicing the leech and head rope of a topsail.

Unlay enough of the small rope to stick the ends once and a half, but of the larger one, unlay for a considerable distance, according to the relative disproportion of the ropes, and the degree of tapering required; crotch, as for a common splice. Take a strand of the large rope, cut away about one-fourth from the under part, and put it, left-handed, through the corresponding strands of the small rope; cut away a few more yarns, and pass it again, back-handed, *round the same strand* of the small rope; and so proceed, working with the same strand of the large rope round and round the same strand of the small one, cutting

away gradually till it is reduced to nothing. Then, one at a time, put the other large strands through in a similar manner, cutting away more or less of the third strand, as may be necessary to give roundness to the splice. Finally, slue round and splice the small strands into the large rope, as in a common short splice, tapering the ends.

A Mariner's Splice is a long splice in a cable-laid rope. Proceed as in a long splice, when, instead of sticking the strands, they in turn are long-spliced; get it on a stretch with luffs, and trim off the ends. This splice is not very often used, for it can be done only with old soft hawsers, which should rather be shroud-knotted, the ends marled down and served over.

Splicing a Hawser, Work a long splice, as with a plain-laid rope, but, instead of knotting the strands, unlay them, marry them together, and tuck them in under the strand that you would reeve them through if you had knotted them in the usual manner; under this first strand of the hawser put all three parts of the strand; under the next, two only; then one, and, lastly, *back* this one.

To Splice a Small Rope to a Chain, Fig. 123, Plate 18. Unlay the end and reeve *two* of the strands through the end link; unlay the third strand (3) some distance back, following it up as in a long splice with one of the other strands (2); half-knot and stick as in a splice; the remaining end. (1), one of the two rove through the link, is stuck where it is, near the link, as in an eye-splice. This is a very neat and strong splice, and is used for tailing rope to chain topsail sheets; for the standing part of a fall where neatness is required, &c.

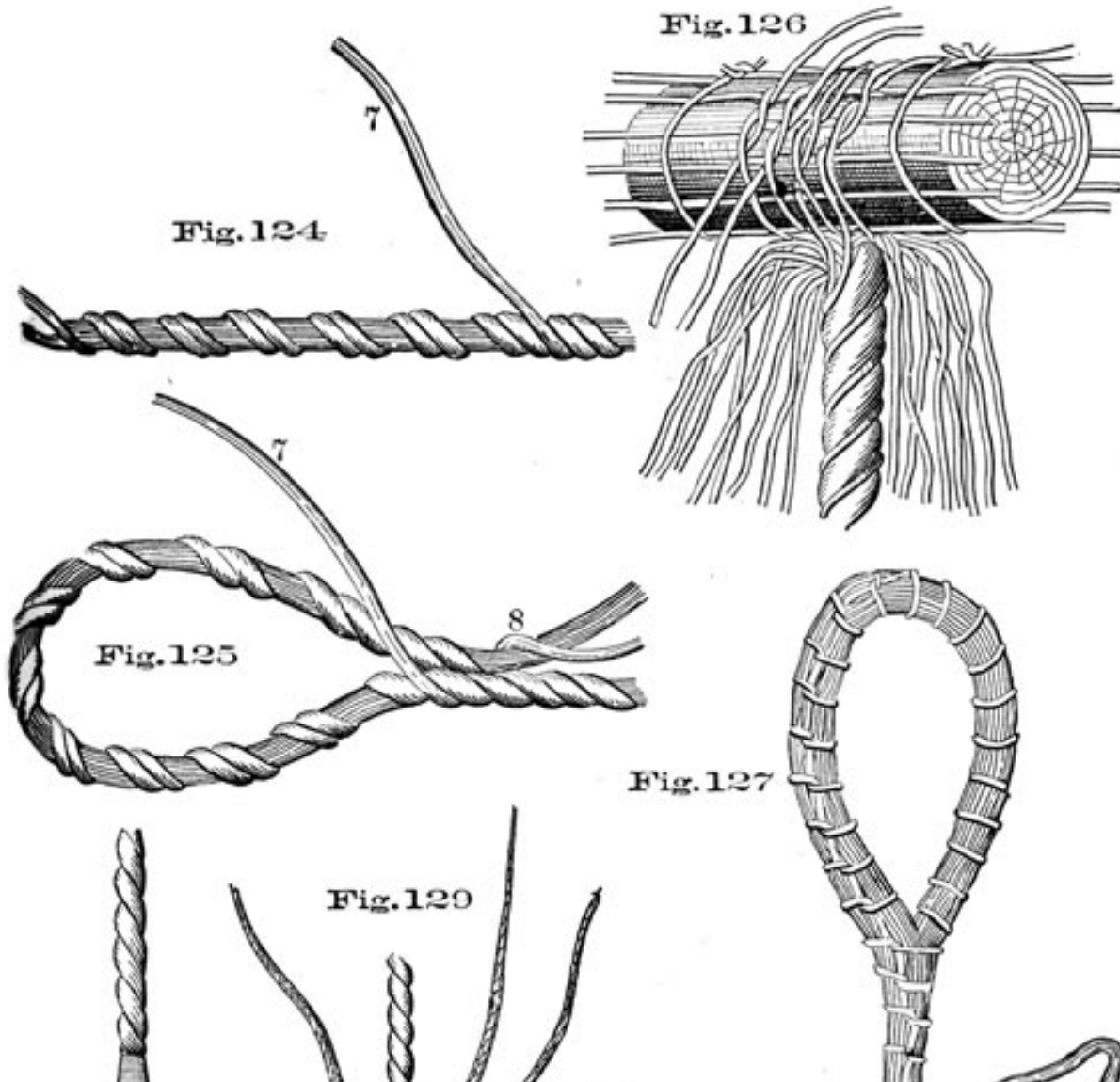
A Ropemaker's Eye is used for forming the collars of stays. A four-stranded stay is unlayed, two strands each way; then each half is doubled back, and laid up with its own part. At the fork, four strands are worked in as in splicing, tapering off by thinning the strands each time they are stuck. The eyes and fork are then wormed and served over. If, instead of laying back *both* strands to the crotch, but one is so treated, while the other is opened out and used for worming, then each lay will be three-stranded, and look much neater.

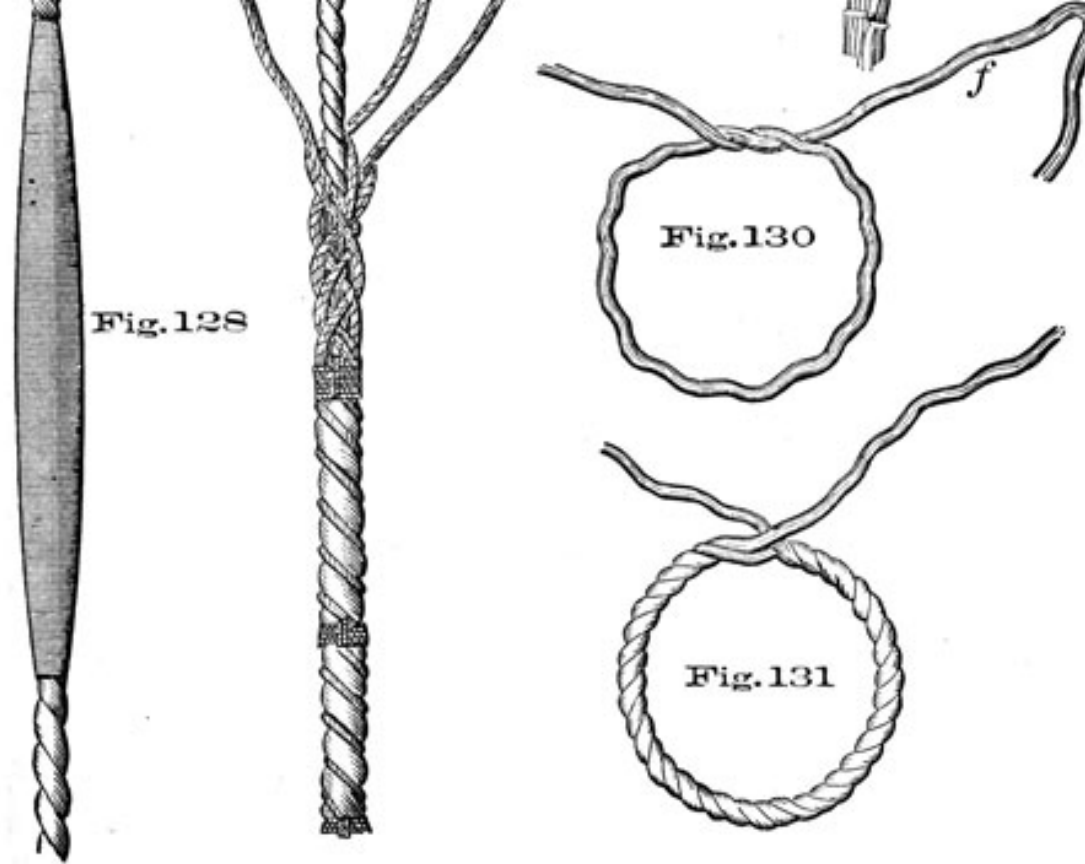
If the rope is *three-stranded*, the eye may be formed in the same way. Unlay the rope, say seven times its own circumference, marl *two* strands together, tar, parcel and form the eye, putting in a thimble or not, as required; unlay the third strand, following it up by one of the strands that formed the eye, to a distance of about eighteen inches; cross the ends and stick, as in a long splice. The other strand that formed the eye is divided into three equal parts, a portion of each is put in the lays of the rope for worming, and the remainder is tapered, marled down and served over with spun-yarn. This, too, may be termed a

ropemaker's eye. It is strong enough to break the rope.

A Flemish Eye, Fig. 125, Plate 19. Take the end of a rope, and unlay one strand (7), Fig. 124, to a certain distance, and form the eye, Fig. 125, by placing the two strands (8) along the standing part of the rope, filling up the intervals (marked by the shade) with strand (7),

Plate 19





till it returns and lies under the eye with the strands (8). The ends are scraped down, tapered, marled, and served over with spun-yarn.

An Artificial or Spindle Eye, Fig. 126, Plate 19, sometimes, though improperly, called a Flemish eye. Put a whipping on the rope at three and a half times its circumference from the end, which unlay. Take a piece of round wood twice the size of your rope, and lash it to a convenient place, having yarn stops on it to stop the eye after it is formed. With a four-stranded rope, unlay the heart and divide it in two; bring the rope under the spar with two strands, and half the heart on each side; pass the heart over and half knot it on top, heaving the rope close up to the spar with a bolt on each side. The width of the eye should be one-third the round of the rope; take from each strand two yarns for every inch of circumference of rope; if a 10-inch rope take twenty yarns, twist them up, and half-knot them on top of the spar, heave taut and pass them down the lay of the rope for wormings; put a spun-yarn seizing on close to the eye, and another about nine inches below, and put a yarn stop around the ends to keep them in the lay of the rope. Take

two-thirds as many yarns from each strand as were used for worming, haul them taut, half-knot them on top, hauling them well taut, and so continue until the yarns are all expended. The yarns must be set well taut alike, or they will not bear an equal strain. Smooth the yarns down and put a stop round all, close underneath the toggle. Half-knot the stops laid lengthwise on the spar, heave them taut with a marling-spike on each side of the eye; form the other half-knot and heave it taut. Marl the eye with two or three yarn spun-yarn; the hitches to be about an inch apart, commencing at the centre of the eye and working both ways; cut the stops as you come to them. Pass a strand round all, close to the spar underneath, and heave taut with marling-spikes, to work the worming taut along the lay; then put on a good spun-yarn seizing. Now tar and parcel the eye and serve it with spun-yarn, fid out, and it is finished, Fig. 127.

This makes a neat eye for the end of a stay. It is frequently used, too, for the lower end of man-ropes where the laniard is spliced in.

When hemp cables were in general use and splicing necessary, they used a **TAPERED SPLICE**, Fig. 128, Plate 19, where the strands were thinned out gradually and the splice served over with spun-yarn a little beyond the entire length; looking, when finished, something like a *mousing*.

Also, the **Drawing Splice**, Fig. 129, Plate 19, used that the splice might be drawn and the lengths of cable separated. After making a short splice, the ends,

which are left long, are tapered off and neatly pointed; these are wormed into the lay, after splicing, and good seizings clapped on at intervals.

A Grommet, Fig. 131, Plate 19, is made by unlaying a strand of a rope, Fig. 130, placing one part over the other, and with the long end (f) following the lay till it forms the ring, Fig. 131, casting an over-hand knot on the two ends, and, if necessary, splitting and pushing them between the strands, as in the long splice. The test of a well-made grommet is, to throw it on the deck when it should lie perfectly flat. Worn or four-stranded rope makes the best. For grommet straps for yard or block, take three times the round of yard or block and three times the round of the thimble, allowing six times the round of the rope for splicing. The length to marry the strands is, once the round of the block and thimble.

Working a Cringle in a Rope. Unlay a single strand from a rope of the size that the cringle is required to be; begin on the left, and put this strand under two strands of the rope you are working it on; divide it into thirds and haul two-thirds of it through, so that the long leg is from you; lay the two parts up together so

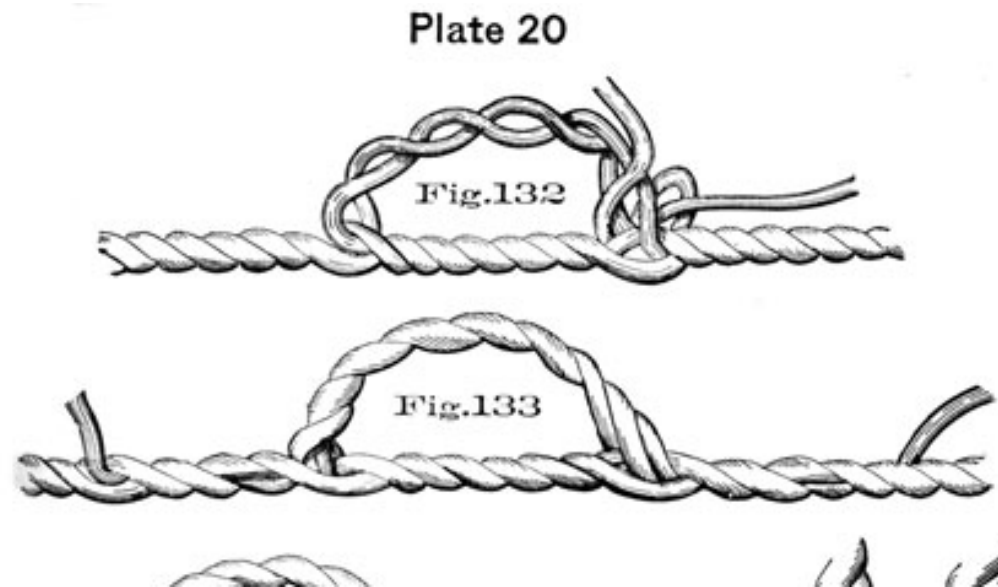
as to form sufficient for the round of the cringle, but always with an odd number of turns, ending with the long leg towards you, Fig. 132, Plate 20; stick it from you under two strands; bring it round and work back to the left; put it under two strands towards you, leaving one strand intervening between the place you entered it, then back over one, and down under two, Fig. 133. Now tuck the short end in under the same two strands in the rope that the cringle is already worked through, then over one, and under two; cut the ends off, and serve the cringle over.

If a cringle is to be worked into the leech of a sail, the strand is taken round the rope and through the eyelet-hole in the sail, Fig. 134, Plate 20, and the ends are finished off by taking a hitch round all, and then passed under two, over one, and under two, as before.

Grommet Muzzle-Lashing for Housing Guns. A grommet made of rope double the size of the gun-tackle falls, with two cringles worked into it for the frapping lashing, which will be of stuff half the size of the tackle-falls.

The grommet should be made large enough just to slip over the swell of the muzzle when the bight is over the housing hook-bolt, and the gun is in position for housing. It should be wormed throughout, and parcelled in the wake of the housing-bolt and frapping-lashing, and when there is no swell, in the wake of the muzzle ring.

When the housing-bolt is an eye-bolt, the grommet is secured to it by means of a toggle which has a lanyard.



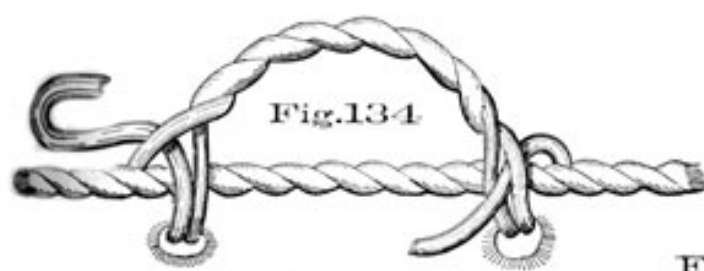


Fig.134

Fig.135 b



Fig.135 a

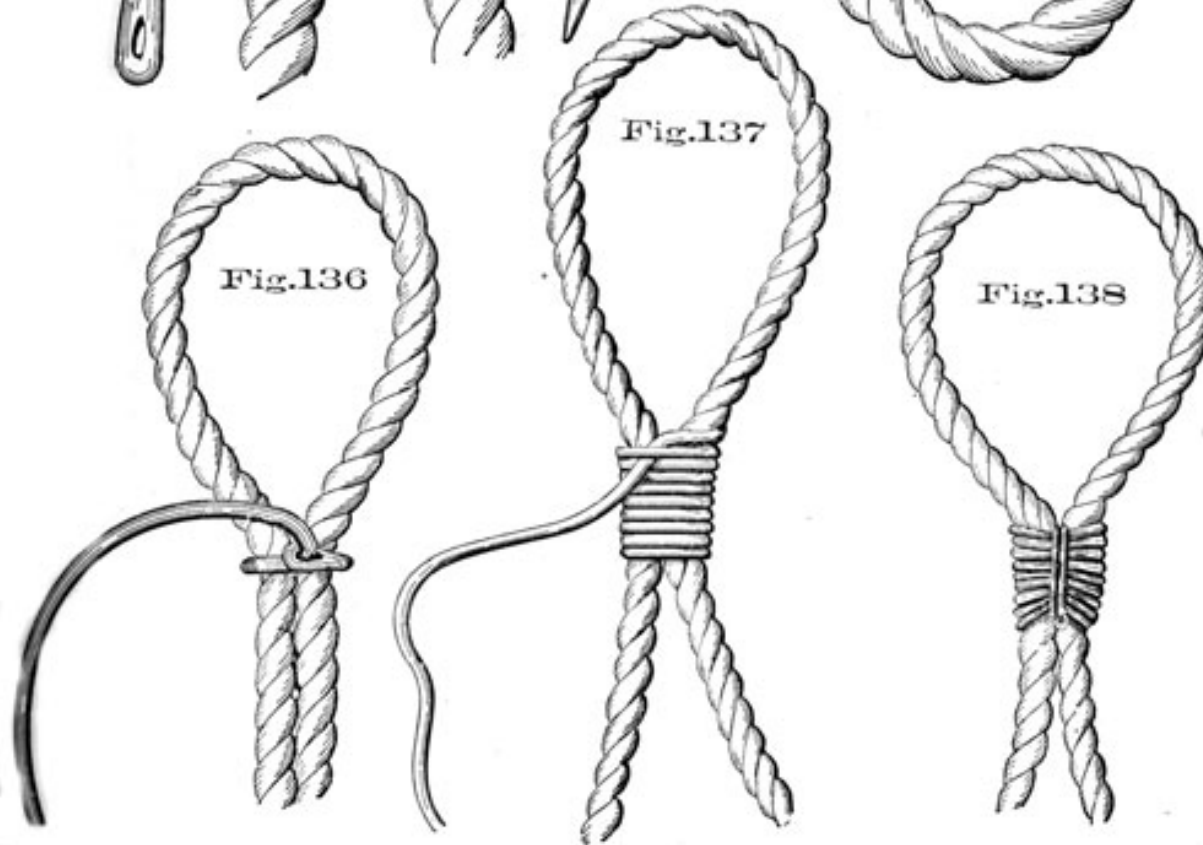
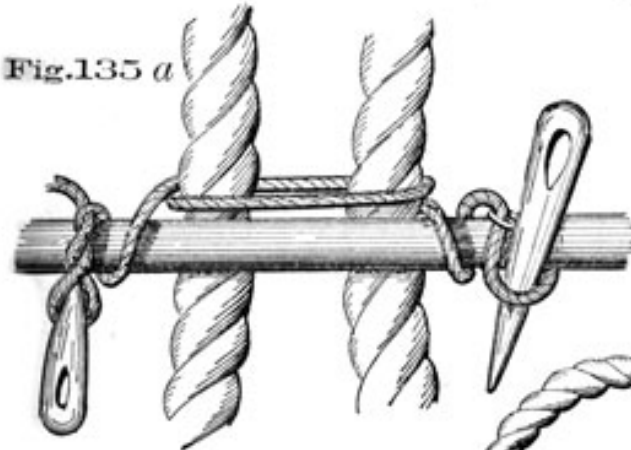


Fig.136

Fig.137

Fig.138

Breechings for all guns are to be made of the best hemp, of three-stranded rope, shroud laid.*

In fitting breechings, a thimble is to be *spliced* into one end, the strands stuck through twice and marled down. A thimble is to be *turned into* the other end, so that the length of the breeching may be conveniently altered. Thus fitted, when the gun is run in and levelled, breechings must be long enough to allow the muzzle of the gun to come a foot inside of the upper port sill, if the breadth of the vessel will allow it. With guns of violent recoil, this distance may be advantageously doubled, where there is room enough, as thereby the strain will be much lessened.

Breechings are neither to be covered, nor blacked, nor rendered less pliable.

SEIZINGS, POINTINGS, GRAFTING, MOUSING, ETC.

Seizing a rope, is binding the two parts together with spun-yarn, house-line, marline, or small stuff.

All seizing stuff should be well stretched before use.

A Spanish Windlass, Fig. 135 (a), Plate 20, is used for heaving two parts of a shroud, or any rope requiring it, together at the nip, before passing the seizing, and for many similar purposes. A strand is laid on the top; the ends are crossed underneath, and brought up on opposite sides, the bights taken round a bar or heaver, laid on the top, a twist is taken in them, and a marling-spike stuck through the bights, and hove upon. See also Fig. 135b.

A Round Seizing, Fig. 138, Plate 20. Splice an eye in the end of a seizing, Fig. 136, and taking the other end round both parts of the rope, reeve it through the eye, pass a couple of turns, haul them taut by hand; then, with a marling-spike-hitch, heave these two turns well taut, by the heaver or marling-spike; pass the rest, and bind them in the same manner, making six, eight, or ten turns, according to the size of the rope; then push the end through the last turn, Fig. 137. Over these, pass five, seven, or nine more (which are termed *Riders*), always laying one less above than below. These are not to be hove too taut, that those underneath may not be separated. The end is now pushed *up through* the seizing, and two cross turns, Fig. 138, are taken betwixt the two parts of the rope and round the seizing (leading the end through the last turn), and hove well taut. If the seizing be small stuff, a *Wall Knot* is cast on the end; but if spun-yarn, an over-hand knot. When this seizing is clapped on the two ends of a rope, it is called an *End Seizing*. If upon

the bight, as in the

* *Shroud-laid*: laid up of the same kind of yarns as used for shrouds, and in the same way.

figure, an *Eye Seizing*, and if between the two others, a *Middle Seizing*.

A Throat Seizing, Fig. 140, Plate 21, is put on when ropes cross, and is passed with riding turns, but not crossed. A bight is formed, Fig. 139, by laying the end (a) over the standing part (b). The seizing is then clapped on; the end put through the last turn of the riders, and knotted. The end part of the rope, Fig. 140, is turned up and fastened to the standing part, as in the figure, with a *round seizing*. This is used for turning in dead-eyes, hearts, blocks, or thimbles.

The riding turns are one less in number than the under ones, as 7 and 6, 10 and 9, etc.

A Round Seizing, second method. Splice an eye in the seizing, pass it under both parts of the rope, and reeve the end through the eye; slack up, lay hold of the upper turn and end part with your left hand, and under turn with your right, and work the seizing round left-handed until enough turns-six, eight, or ten-are wound round, Fig. 141, then reeve the end back between the upper and under turns, and bring it up through the eye; heave each turn taut separately, keeping the eye on the left-hand side, Fig. 142. When you have hauled the end taut through the eye, pass the riding turns round, in the same direction as at first-one in number less than the under turns, and haul hand-taut, Fig. 143. When all on, pass the end down between the last two parts of the upper side of the inner turns, between both parts of the rope, and pass two round turns, crossing all parts of the seizing, Fig. 144; then slue the rope over, and finish off with a reef-knot, Fig. 146, on the under side, or as in Fig. 145.

Racking Seizing, Fig. 147, Plate 21. This seizing is generally made use of in seizing two parts of rope together temporarily, but very securely. When the seizing stuff is fitted with an eye, as in the figure, it is taken *around* both parts of the rope-the end rove through the eye, and hauled taut, after which it is passed *between* the two parts of the rope, *around* the part opposite the eye (of the seizing), back *between* the ropes, and so on, each full turn, when passed, resembling a figure 8.

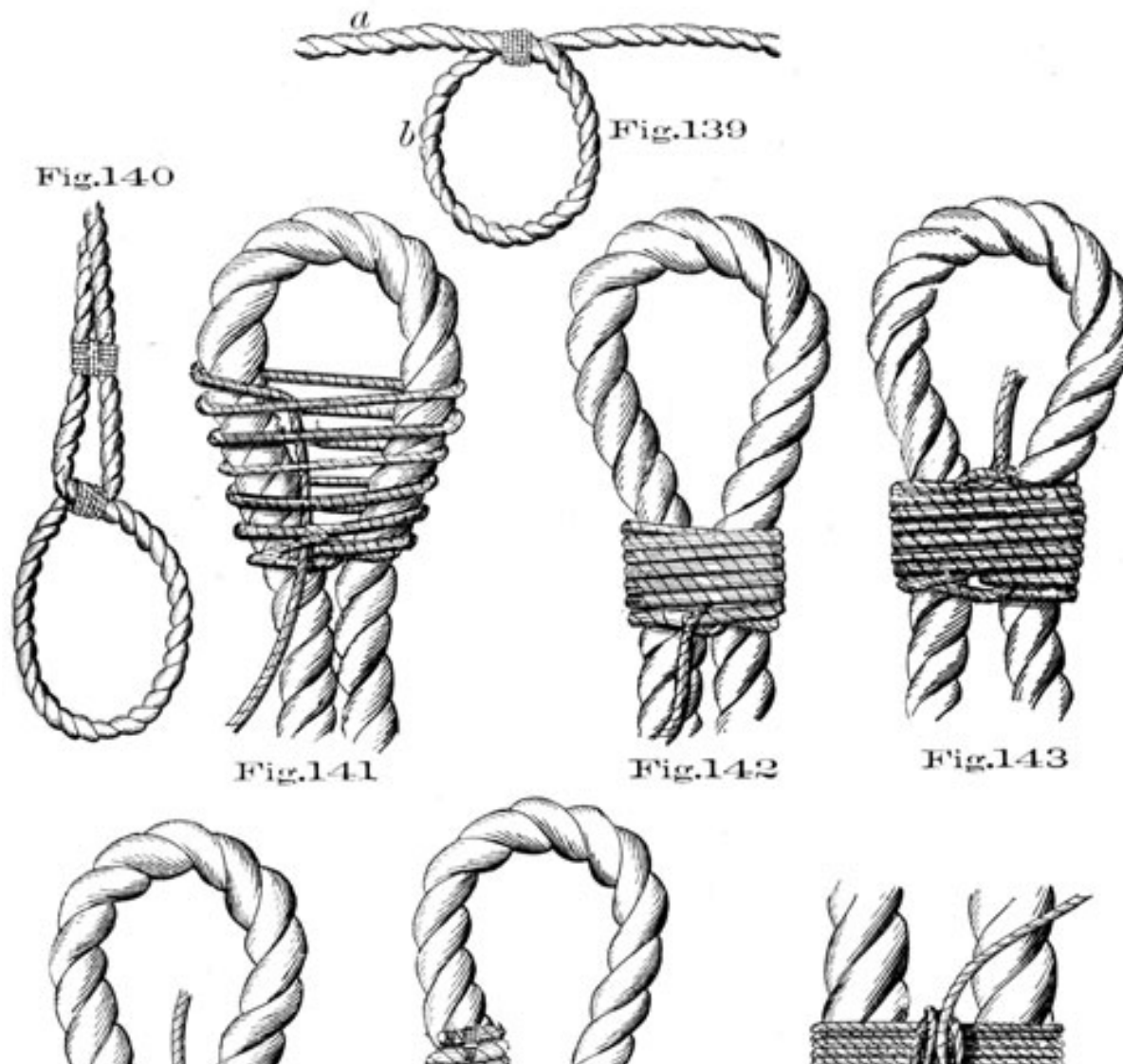
Each turn is drawn taut in succession, and the last one is secured by passing the end between the parts of rope *inside* the last turn, thus jamming it by the hitch formed.

The two lower turns of a throat seizing should be passed as *racking* turns; and, thus passed, serve well to fill up the open space between the parts of rope, as they are brought together.

A **Flat Seizing** is commenced the same as a round seizing, but, on the end being rove through the eye, it is finished off at once with a reef-knot without any riding turns.

A **Cuckold's Neck, or Half Crown**, is

Plate 21



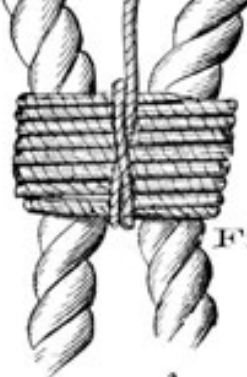


Fig.144

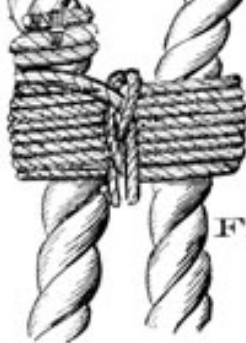


Fig.145



Fig.146



Fig.147



Fig.148

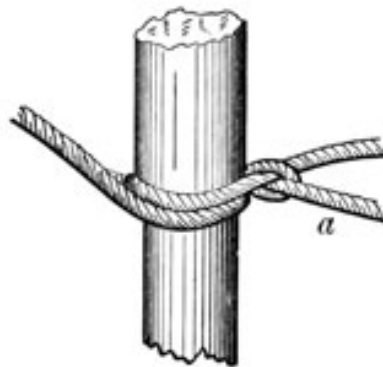


Fig.149

Plate 22

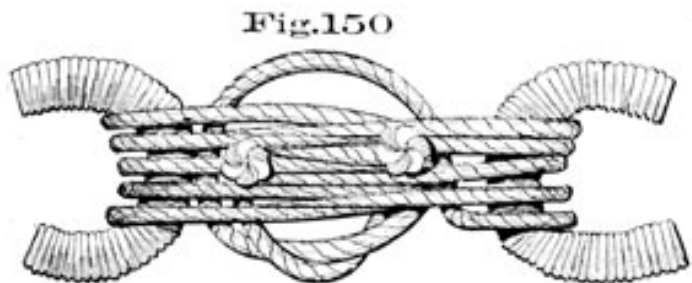


Fig.150

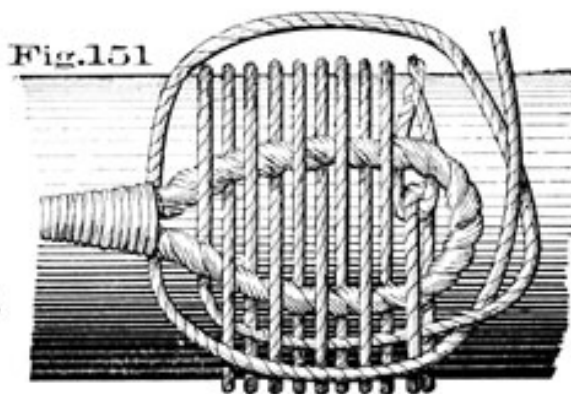


Fig.151



Fig.154



Fig.156



Fig.157



Fig. 152



Fig. 155



Fig. 153



Fig. 157

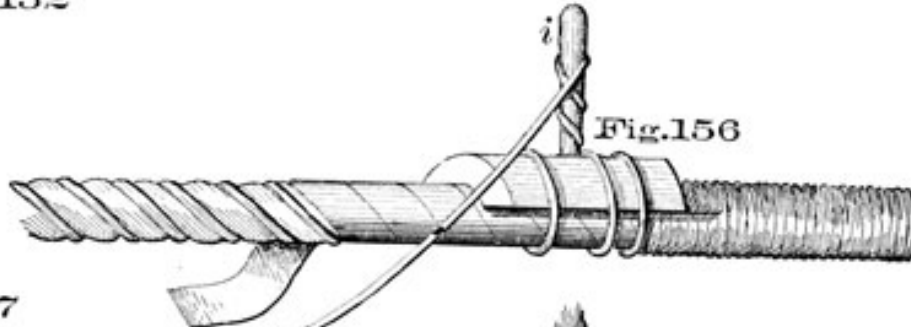
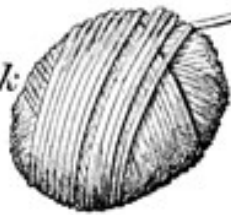
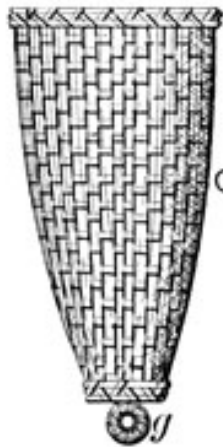


Fig. 156



k

Fig. 159



c



Fig. 161

Fig. 158



Fig. 160



formed as Fig. 148, Plate 21, with a round seizing. Used when ropes are fitted for going over a spar, as in Fig. 149, at a.

A Rose Seizing, or Rose Lashing, Figs. 150 and 151, Plate 22, is used when rigging is lashed to yards, etc., such as foot-ropes, &c. It is passed alternately over and under each part of the eye, and the end passed around the crossings instead of cutting it off.

Stopping, is fastening two parts of a rope together, like a round seizing, but not crossed.

Nippering, is making fast the two parts of a laniard or tackle-fall, while the purchase is fleeted. The turns are taken crossways, Fig. 152, between the parts to jam them; and frequently a *round turn* is taken over the laniard, before every cross: these are called *racking* turns. Riders are passed over these, and the end fastened with a round turn and half hitch, or with a clove hitch, to a part of the laniard or fall.

WORMING, SERVING, POINTING, GRAFTING, MOUSING.

Spun-Yarn is used for *Worming, Serving, Seizing, &c.*, as a general rule, but *Hambroline, Rounding*, and small seizing stuff is frequently substituted.

Worming a Rope is filling up the division between the strands (called the *lay* of the rope) by passing spun-yarn, &c., along them, Fig. 153. This is done in order to strengthen it, for various purposes, and to render its surface smooth for parcelling. After being passed by hand, worming is hove on by a soft strand knotted and taken round the rope; a bolt is then passed through the bights, and the strap twisted up and hove round the rope, which tautens the worming as it proceeds. With very large rope, the worming requires *backing** on each side with smaller stuff, in order to fill it up properly. If the rope is not to be served, a seizing, snaked, should be put round the worming at intervals, to keep it in its place, as it is liable to work slack.

Worming is in length about once and a half the length of the rope to be wormed, for each piece.

Parcelling a Rope, is wrapping strips of old canvas round it, well tarred, with edge overlapping, which prepares it for serving and secures it from being injured by rain-water lodging between the parts of the service when worn, Fig. 156. Parcel with the lay, if service is to be used, otherwise against it.

Service is put on to protect the rope from chafe and the influence of weather. It is clapped on by a wooden mallet, Fig. 154, made for the purpose. The mallet is round at the top, but has a groove cut in the head of it to receive the rope, that the turns of the spun-yarn may be passed

* Also known as *sister* or *side worming*.

with ease and dispatch. The rope is first bowed hand-taut by a tackle, then wormed. The end of the spun-yarn for the service is laid upon the rope, and two or three turns passed round the rope and over *it* (the end), hauling them very taut. The mallet is laid with its groove upon the rope, Fig. 156; a turn of the spun-yarn is taken round the rope and the head of the mallet, close to the last turn which was laid by hand; another is passed in the same manner, and a *third* also on the *fore* part of the mallet, leading up round the handle (i), which the rigger holds in his hand. *The service is always passed against the lay of the rope*, so that as the latter stretches, the tension of the former is not much decreased. A boy holds the ball of spun-yarn (k), at some distance from the man who is serving, and passes it round, as he turns the mallet, by which he is not retarded in the operation. The end is put through the three or four last turns of the service, and hauled taut.

A serving board, Fig. 155, is used for small jobs.

Two men can worm, parcel and serve two fathoms of twelve-inch rope in an hour.

Spike-serving is used when you have a small eye or similar piece of gear to serve. The turns are passed by hand, and each is hove taut separately by taking a marlingspike-hitch over a marling-spike, and with the point prizing it against the rope until the service is taut.

Whipping a Rope, Fig. 157, Plate 22, is done to prevent the end from fagging out. Place the end of the whipping stuff in the lay of the rope, pointing up towards the end, and pass a few turns round the rope, binding the end of the whipping; then laying the other end on the turns already passed, pointing downwards, pass the remainder on the bight, hauling through on the end part and cutting off.

The "Square" and "Sharp-up" marks on braces are put on in a similar manner; the last turns being passed slack, and the end stuck through.

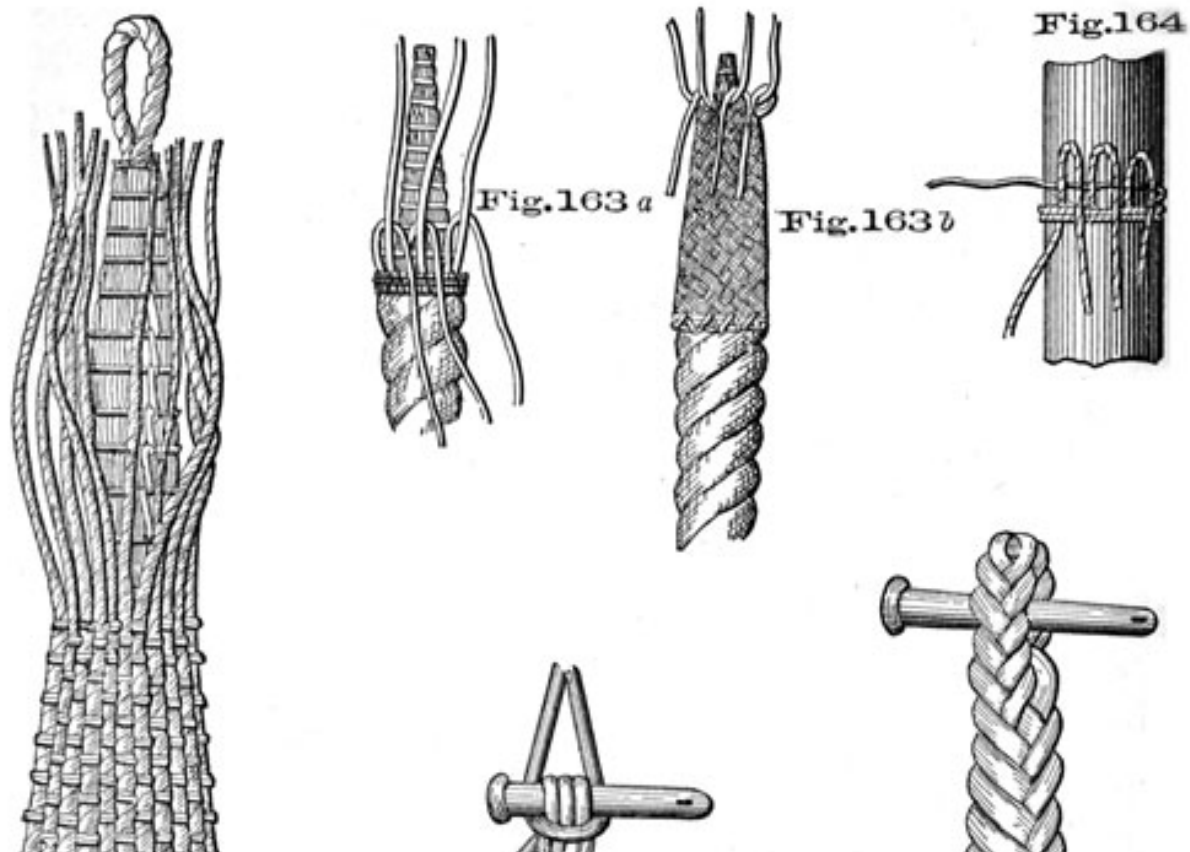
A Sailmaker's Whipping is put on with a needle and twine—a reef point has such a whipping. Pass a stitch through the point, take several turns, stick through again, and pass cross turns from one end of whipping to the other in the direction of the lay of the rope.

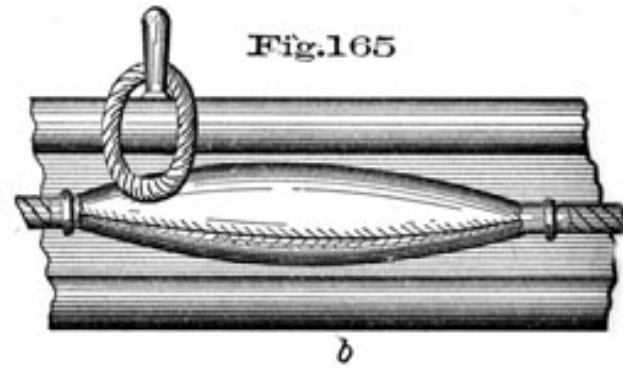
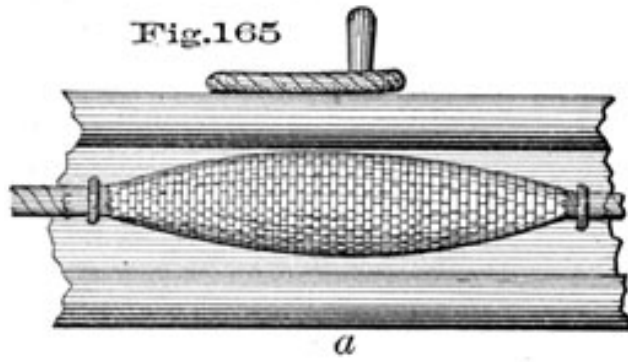
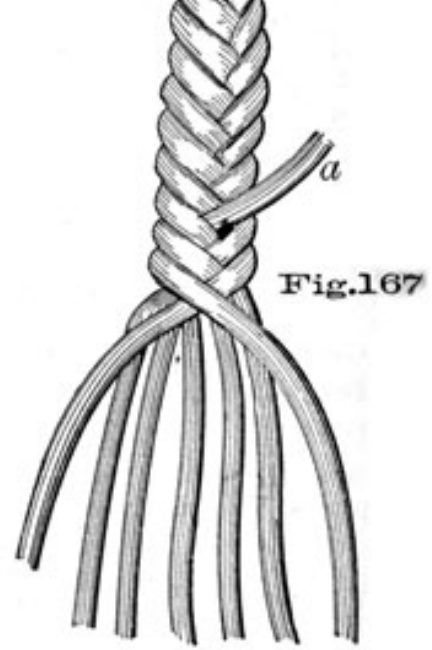
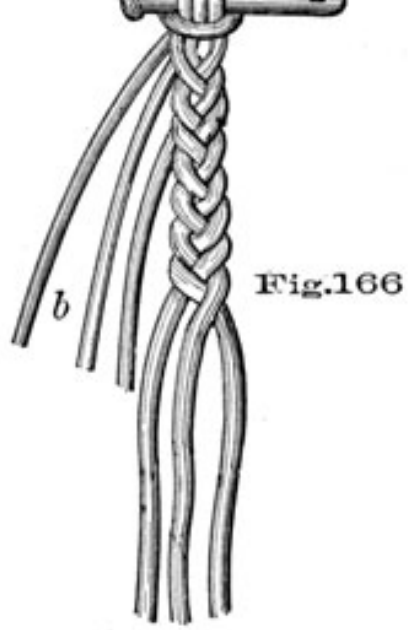
CROWNING, POINTING, SNAKING.

Crowning the end of a Rope is a rough substitute for a whipping. With the three strands form a crown, then stick the end once or twice as in splicing.

To Crown a Hawser. Put a stout whipping on the hawser, a sufficient distance from the end to allow for crowning. Unlay the strands to the whipping, and lay the three inside, or heart strands up together. Then form

Plate 23





the crown with the three *outside* ones, taking them above, and covering the remaining three, which, with the heart strands, should be whipped, and cut off even. Lastly, worm the ends of the crowning strands back into the lay of the hawser, and clap stout smooth seizings close up to the crown, and at the extremity of the worming. Sometimes an artificial eye is formed with the inner strands.

To Point a Rope, Figs. 160 and C, Plate 22. Unlay the end of a rope as for splicing, and stop it. Take out as many yarns as are necessary, and make nettles: (this is done by taking separate parts of the yarns when split, and twisting them.) Comb the rest down with a knife, Fig. 158. Make two nettles out of every yarn which is left; lay half the nettles down upon the scraped part, and the other, back upon the rope, Fig. 159. Take a length of twine, which call the *Filling*, and pass three turns very taut, jamming them with a hitch at (a). Proceed, laying the nettles backwards and forwards as before, and passing the filling. The ends may be whipped and snaked with twine, or the nettles hitched over the filling, and hauled taut. The upper seizing must also be snaked, Fig. 160. The pointing, will appear like Fig. C: a small becket is often worked at the end, when the rope is large (g). If the tapered part be too weak for pointing, a piece of stick may be put in, proceeding as before.

Snaking is for the better securing of a seizing, which is passed round the single part of a rope, and therefore cannot be crossed. It is done by taken the end part under and over the lower and upper turns of the seizing, Fig. 161, Plate 22.

Pointing Large Hawser. Clap on a whipping of three-yarn nettle-stuff, snaked. Open out the strands, lay the heart up three-stranded, and splice a becket into it, which has previously been eye-spliced into its own part. Lay the outside yarns up into five-yarn sennet; use, for filling, a two-yarn fox; and continue as already shown Fig. 162, Plate 23.

Cross Pointing. Commence as for straight pointing, and, having laid the nettles, one up and one down alternately, bring an upper nettle down to the right of its corresponding lower one, Fig. 163 a, lay the lower one up, and work in this way once round to the right; commence again, and bring what are now the upper ones down to the *left* of the lower nettles, lay the lower ones up, and so work round backwards; then, bring them down again to the right, and so go on. Finish off with two turns of straight pointing as in Fig. 163 b, Plate 23.

Hitching is a very convenient method for covering boats' awning-stanchions. The nettles to be used are middled, laid along the article to be covered, and secured in their places with a turn of filling. If working from one

end, as in the cut, Fig. 164, all the nettles are taken up; if working from the centre towards the ends, the nettles on each side of the filling supply their own end. The turn of filling being passed and hitched as in pointing, commence hitching the nettles round the filling, hauling each taut separately, working to the left, keeping the filling taut, and going round and round. If what you are covering, contracts in circumference, you must leave out a nettle occasionally, and cut it off; and should it increase, lay fresh ones in. It is finished off by keeping the bights of the last round slack until you have passed a couple of turns of the filling and hitched it as in finishing off pointing, when in the same manner haul the bights close down, and cut the ends off.

Grafting, as understood now, is when a strap, ringbolt, or other article, is to be covered over entirely. It is done as in pointing, using instead of the rope-yarn nettles, log-line, or fishing-line, according to the size required.

PUDDING FENDERS, OR DOLPHINS.

Pudding Fenders, or Dolphins, are used in the navy for launches, being placed outside the boat just under the gunwale, and permanently secured there.

A piece of rope of the required length is cut, and an eye spliced in each end, by means of which it is set up to small eyebolts under the gunwale; the rope is then marked where the puddings are to be worked. Worm the rope and form the *puddings* with any old stuff, such as old strands laid lengthwise along the rope, raising the pile in the centre and scraping off the ends to a taper. Or make a tapering pudding by winding spun-yarn around the rope. In forming the pudding, the sides intended to be next to the boat are flat, and the outer sides a half round.

When formed to the required shape, parcel the pudding and graft it over, as in Fig. 165a, or cover with leather, as in Fig. 165b.

The whole fender is commonly known as a *dolphin*.

FOXES-GASKETS-TURK'S HEAD.

Foxes for gaskets, &c., are made by taking a number of rope-yarns, from three upwards, according to the

size intended, and twisting them on the knee, rubbing them well backwards and forwards with a piece of canvas. Spanish foxes are made by twisting single rope-yarns backhanded in the same manner.

Gaskets, Fig. 167, Plate 23, are made by taking three or four foxes, according to the size, middling them

Plate 24



Fig.168

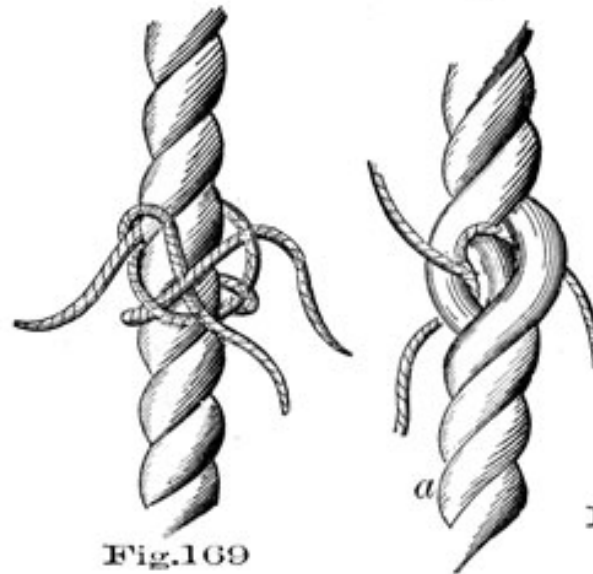
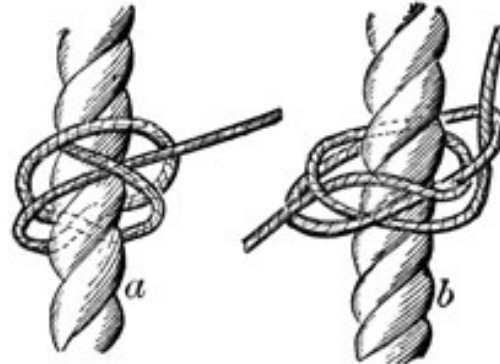


Fig.169

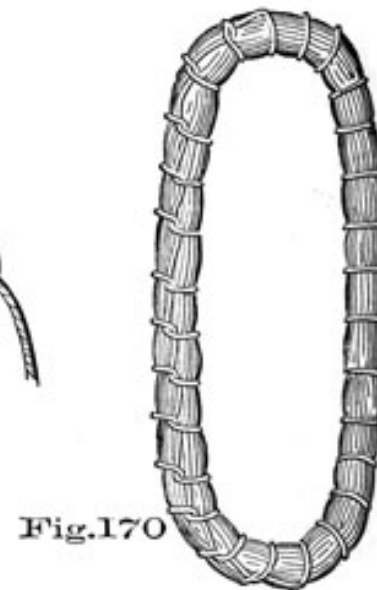


Fig.170

Fig.171



Fig.174



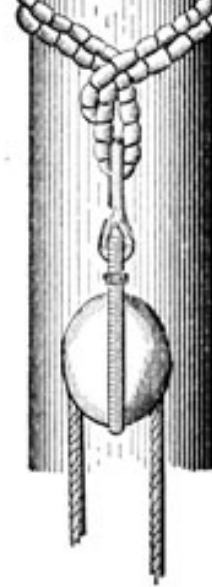


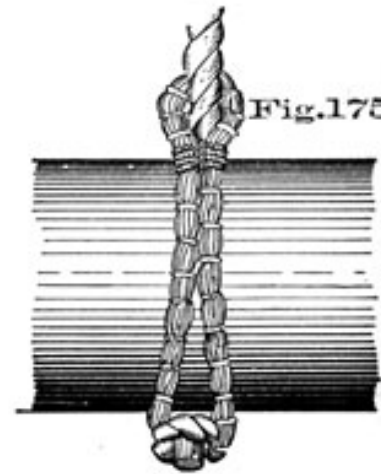
Fig.172



Fig.173



Fig.175



over a pin, &c., and plaiting the three or four parts together for the length of the eye, Fig. 166. The plaiting is formed by bringing the outside fox on each side alternately over to the middle. The outside one is laid with the right hand, and the remainder held and steadied with the left. When this is done, take the other parts (b), (having shifted the eye part so that it lies over the bolt, Fig. 167), and work the whole together in the same manner; add another fox at (a), and work it for a convenient length, then diminish it towards the end, taking out a fox at proper intervals. When finished, one end must be laid up, the others plaited, and then the one end hauled through. This is the same work used in making ordinary sennit.

Sea gaskets or furling lines are made in this way, though not tapered.

Turk's Head. Take two round turns round the rope, Fig. 168, Plate 24, pass the upper bight down through the lower, and reeve the upper end down through it, Fig. 168 (a); then pass the bight up again and reeve the end over the lower bight, and up between it and the upper one, Fig. 168 (b); dip the upper down through the lower bight again, reeve the end down over what is now the upper bight, and between it and the lower, Fig. 168 (c); and so proceed, -working round to your right until you meet the other end, when

you pass through the same bight, and follow the other end round and round until you have completed a plait of two, three, or more lays, as you wish. Fig. 168 (d), shows a Turk's head of two lays.

Turk's head worked into a Rope. This is done when the knot has to resist a strain, as the rung or round of a Jacob's ladder. You middle the marline or nettle-stuff that you are working with, and splice a second piece into the centre so as to form a third leg; then pass an end through the rope, and haul it through to the junction of the third leg, which reeve through the third strand of the rope, bringing an end out between each strand, Fig. 169 (a), Plate 24. Then crown the ends round the rope, left-handed; slue round, and crown them back, right-handed, and the knot will appear as in the Fig. 169. Follow each part round with its own end, cut the ends off, and it will appear like a Turk's head. With four-stranded rope use four ends.

SELVAGEES-REEFING BECKETS, ETC.

A Selvagee is made by warping. rope-yarn, spun-yarn, or small stuff, according to the size required, and marling down as in Fig. 170, Plate 24.

A small selvagee may be made by warping rope-yarn

around two marling-spikes, stuck in the holes of a grating at the proper distance apart.

Large ones are sometimes made of small stuff, for getting in lower masts, and are called *garlands*.

As selvagee straps are soft and pliable, they are the best for clapping on rigging, spars, &c. as in Figs. 171 and 172.

For the same reason, stoppers &c., braces, &c., are made in a similar manner, as in Fig. 173.

Selvagees may be used for various purposes. A very neat and expeditious way of bending studding-sail halliards is to use a strap, as in Figs. 174 and 175.

Very neat straps for blocks, may be made of selvagees.

Reefing Beckets, Fig. 177, Plate 25, are made like sennit, after a variety of designs.

These points may be made of manilla-yarns, or four-yarn spun-yarn, with four or five parts in the eye, and worked down with seven or nine parts; the length of the spun-yarn on the two parts to make a point, is once and a half the length of the point to be made. The eye is made around a toggle which remains in. If fitted to go around the jack-stay, plait down six inches from the toggle, then separate the foxes and plait an eye eight inches long, then plait down nine inches solid, whip the end with twine and it is finished.

Sometimes the points or becketts are fitted to go round the yard, with a short eye to go over the toggle, and the toggle part is seized to the jack-stay. To make these, plait down from the toggle four inches longer than the round of the yard, where it would be placed, separate the foxes and plait an eye three or four inches, according to size of sail, then plait down solid four inches, another eye eight inches long, and solid again for nine inches, whipping the end with twine. When rope points are used, they are made as follows, supposing them to go round the yard: Cut the rope, which should be four-stranded, about three feet and a half longer than the round of the yard. Splice one end round the toggle, put a whipping on the rope about four inches longer than the round of the yard from the toggle; then divide the rope in two up to the whipping, and form an eye four inches long, with two strands on each side, then lay up four inches solid, and form another eye eight inches long; then lay up nine inches solid, and whip the end with twine. Now finish the eyes by taking a strand of the same sized rope four times the length of the eyes, pass it through the rope at the lower part of the eye, and lay one end up each side of the eye to form a three-stranded rope, splice them into the standing part and it is finished, as in Fig. 176, Plate 25.

Plate 25

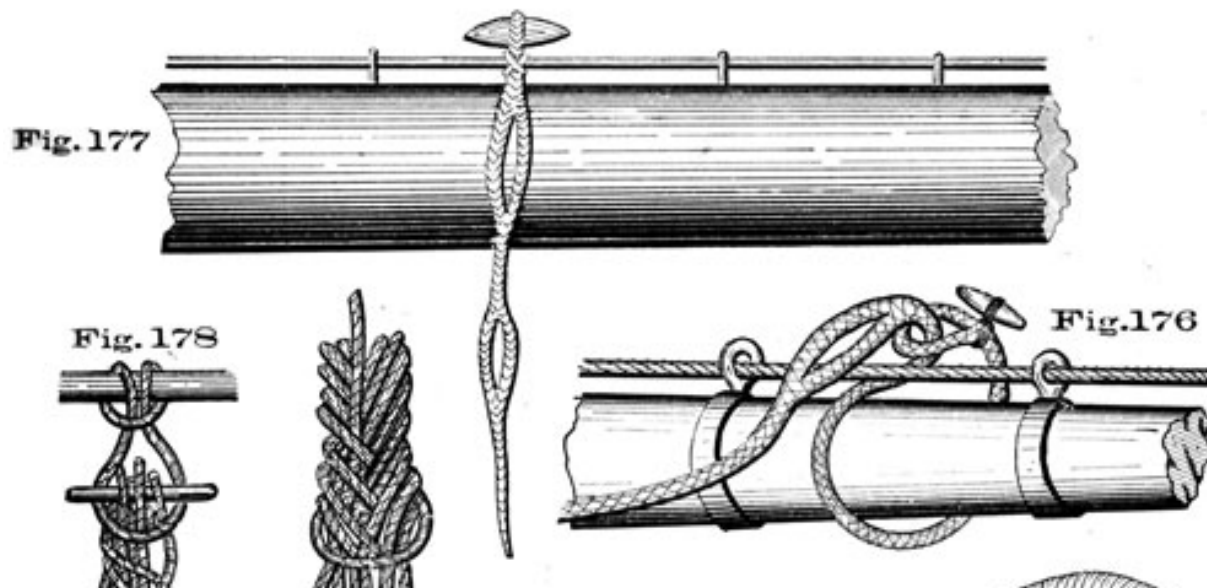




Fig. 180

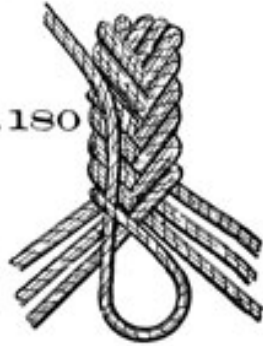


Fig. 179



Fig. 182

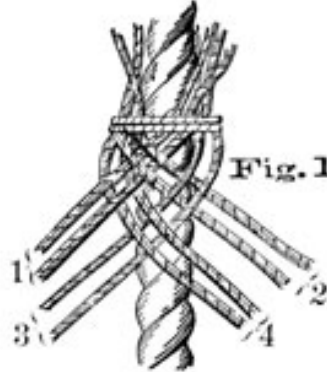


Fig. 183

Fig. 181



Fig. 184

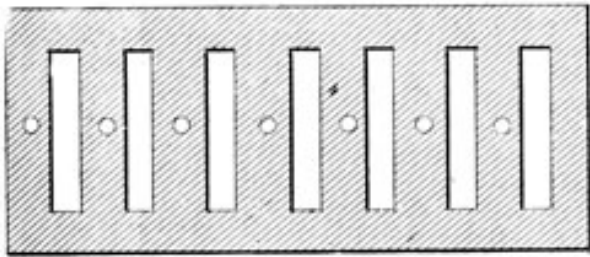


Fig. 185

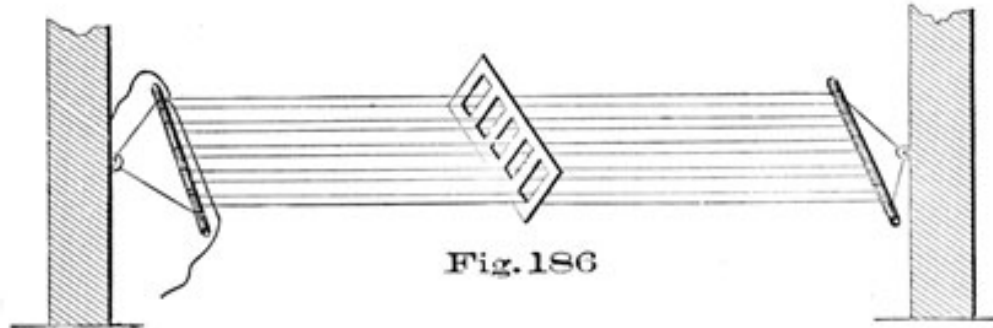


Fig. 186

SENNIT.

Common Sennit is made with an odd number of nettles. If, however, an eye is to be formed, you commence with an even number—one being a short one; and after the eye is formed, the short end is worked in, or, if too long, left out and cut off—leaving an odd number to go on with. We will suppose that a reef-point is to be made of seven parts of spun-yarn:—Cut off four lengths (one being but little more than half the length of the others), middle them, toggle the bights through a becket triced up before you, halve the nettles, lay the right-hand nettle over the next one to it, bringing it over to the left, making three now on your left, and one on your right; Fig. 178, Plate 25, bring the outside nettle on the left over two, which will equalize them again; then the right over one, left over two, and so on alternately till you have worked length enough for the eye; next bring all eight parts together, halve them, and go on as at first—right over three, and left over four. When two or three lays are worked in this way, leave out the short end, and continue with seven parts—right over three, and left over three in succession. Finish off by forming a bight of the left-hand nettle when you bring it over, laying the end up; and as you work the remaining nettles in, point them down through this bight; and, when all are in, secure them in their places by hauling the bight taut through upon them, and cutting the ends off, Figs. 179 and 180.

French Sennit, like common Sennit, is made with an odd number of nettles. If about to make a harbor gasket for a royal yard in this manner, of nine parts of nettle-stuff, cut off five lengths (one being a short one), middle them, put a seizing round the bights to form the eye, which marl down, and serve over; then bring all nine parts together (having left out the short one after the seizing was passed), and divide them, with five to the right, and four to the left; weave the outside one on the right, over and under the nettles on its own side, bringing it out to the left, then do the same with the outside nettle on the left, and lay it out to the right, when there will be again five on the right, and four on the left, and so continue.

Harbor gaskets are made in this way, and also the *backers* which nail on the topsail and lower yards for head-earings to haul out to, as in Fig. 181, Plate 25.

Round Sennit is used for man-ropes, yoke-lines, &c., Figs. 182 and 183. Stretch a heart of small rope taut along between two belaying pins, or other convenient fixture; take 8 (12, 16, or more) nettles, put a whipping round the heart and ends, to hold them, divide them into fours of 2 (3, 4, or more) parts each; then lay No. 1 pair

over the heart, to your left; then No. 2 to your right, crossing the first pair; next No. 3 pair under all to the right, and over No. 2; No. 4 round under all to the left, and over No 3; then No. 1 round to the right, under No. 2, and over 4, 2 round to the left, under 3, and over 1; and so on, always bringing the upper pair on the opposite side, to cross over the pair last passed. Finish the end off by pointing the heart with the nettles made into smaller ones; and finish the top by walling and crowning the heart, covering it with duck to round it, then double-walling and crowning the nettles over the heart knot, previously whipped underneath, with a Turk's head to cover the whipping. Or, after forming the knot of the heart, and covering it, and putting the whipping round the nettles underneath, you may cut 1 them off, and cover the knot with Turk's heading of mackerel line, begun very slack, and spread over the knot, by passing with a sail-needle, as many lays in the plat as will be required to cover the knot.

Square Sennit is used for the same purposes as round sennit, and also by engineers, as packing for pistons. It is made somewhat in the same manner as round sennit, but without a heart. Nettles are used in the same ratio, increasing by fours, but are worked singly instead of in pairs. Having put a whipping round the (eight) ends, divide the nettles, and lay half on each side; bring the uppermost left-hand nettle round underneath all, and up inside two, and over two of the right-hand ones-crossing over the latter ones to the left, and making four on each side again; then take the uppermost of the right-hand nettles, pass it underneath, and under two, and over two of the left-hand ones-still keeping four on a side, because the nettle taken up always comes round to its own side again. To proceed, take the upper nettle on each side alternately, and finish off as you finish round sennit. One man can make a fathom and a half of 9-yarn sennit in an hour. Fig. 184, Plate 25.

SWORD MATS.

Sword Mat. At a distance apart, equal to the length of the mat, sling a couple of bars in a horizontal position. Hitch one end of the warp to the bar at the end on which you intend to terminate the mat; take up the comb, which is made of a wood perforated with holes and slits alternately, Fig. 185, reeve the other end through the first hole, over and under the bar at which you intend to begin, back through the first slit, under and over the other bar; and so wind off as many parts as are required for the breadth of the mat, the last turn being rove through a slit, and secured to the bar at which you finish off, Fig. 186. This done, lift the loom up, middle the filling, and lay it

Fig.187

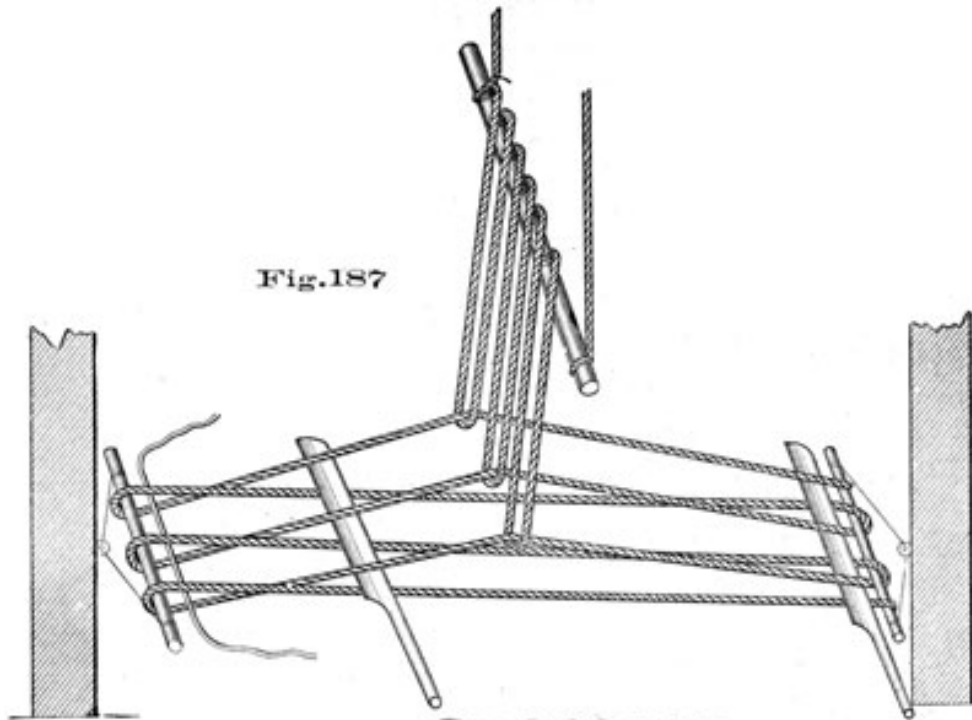


Fig.188

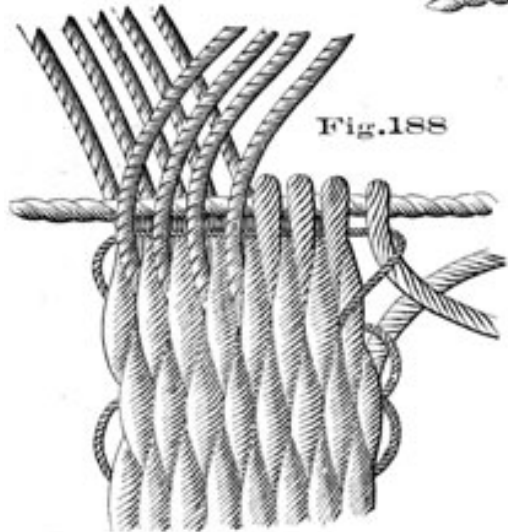


Fig.191

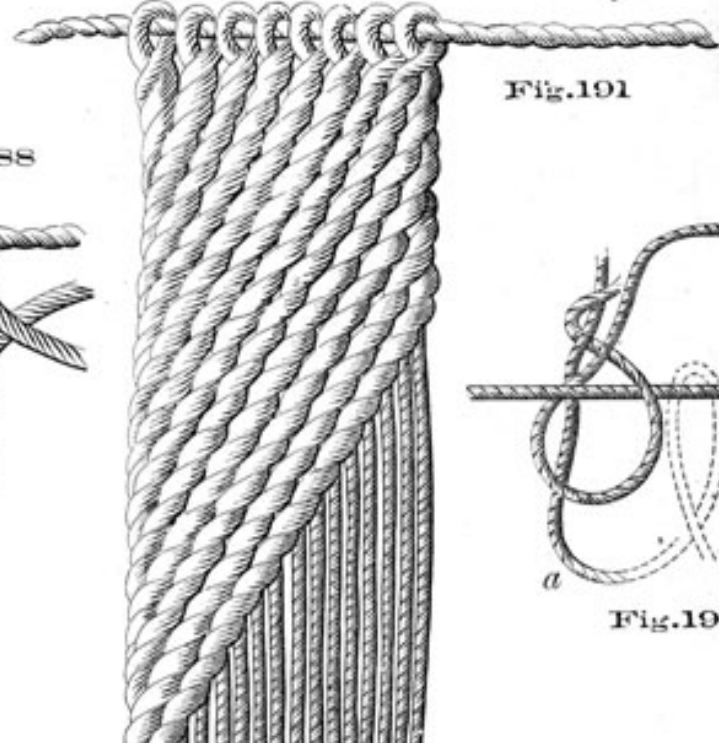
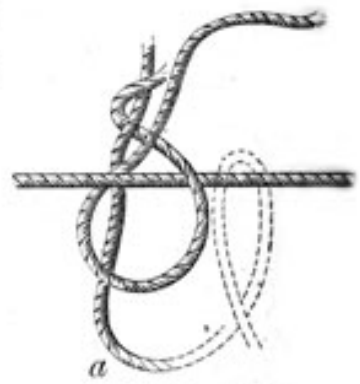


Fig.192



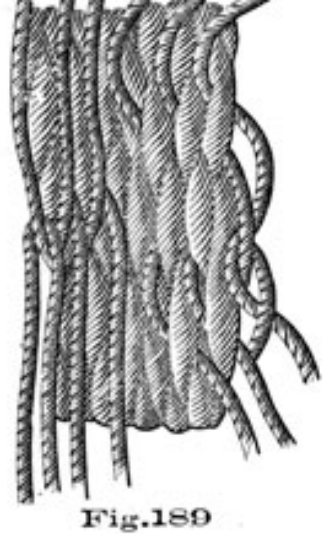


Fig.189

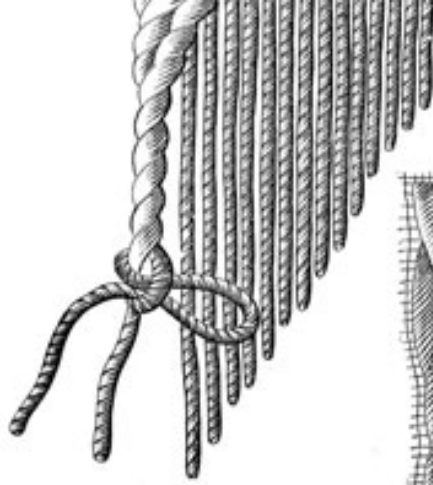
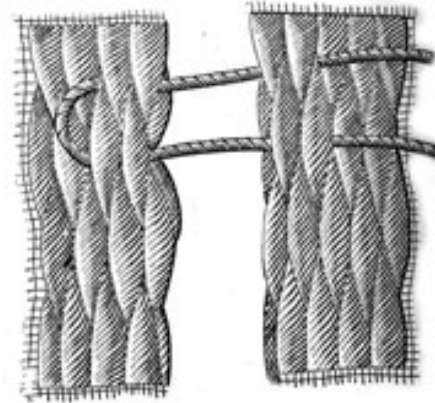


Fig.190



between the upper and under parts; then lower the loom, and the parts that were lowermost will rise in the slits, become the uppermost, and thus put a cross in the warp. Next put the sword, made of hard wood in the shape of a knife, in between the upper and under parts, and drive the crossing close up towards the bar, and harden it well up, Fig. 187; then pass a turn of filling to secure the crossing, reeving the ends through contrary ways, haul it taut, take out the sword, lift the loom up, and go on again. When you come to the last turn of filling, half-knot it with two turns.

If you have to make a mat for which your loom is not large enough, you rig a fiddle, by slinging a handspike athwartships to the main-deck beams overhead; pick up every other part of the warp, and with a piece of nettle-stuff passed over the handspike with *two round turns*, and rove round the alternate parts of the mat, trice them up. The upper parts will thus cross the under parts before and abaft the fiddle, and you will require two swords. Reeve the filling, and secure the first crossing already formed, by the parts being triced up, in the ordinary manner, hardening it up with the first sword; now, put the second sword in between the crossing and the bar abaft the fiddle, give the mat a shake, to disengage the parts, and with the sword lift the upper ones up. The crossing will thus be extended before the fiddle; so withdraw the first sword, put it in abaft this crossing, drive it up and secure it with a turn of filling; again lift up the fiddle, keeping the second sword fast (which is never removed); a crossing is again formed at each end; and you again repeat the operation. Fig. 187, Plate 26.

With a heavy boom-mat five or six feet wide, you require a second fiddle underneath, to rouse the parts

through. A couple of hands jump down on the handspike; and the upper one, which is triced up by a couple of jiggers, is lowered at the same time.

To finish off or *selvage* the mat:-After passing the last turn of filling, and securing it with a half-hitch with two turns, you lay the laniard across on the top of the filling, and commence unreeving again the front row of nettles, one at a time, beginning on the right. As you withdraw them you bring the corresponding nettle, at the back, over the laniard and filling, and reeve it back through the hole left vacant by the one hauled out. See Fig. 188, Plate 26. Go right across and haul the bights taut down to the laniard. On slueing the mat round, you will find that this will leave the second row of filling bare; so go on withdrawing the same ends again, along the second row, and pointing the same reeving ends, as at first, through the holes the others came out of, covering the filling, and complete four or five rows of this in the same manner. Then, to cover the last row of filling, and to secure the ends of the nettles, you lay them up and down alternately, the long

56

ends that you have withdrawn going up, and the short ones that you have been reeving, laying down; haul them taut, beat them in, and then tuck them under the bights of the next lay, the lower ones left-handed through the bights to the right, and the upper left-handed to the left. Beat the mat down and cut the ends off. Fig. 189.

To finish off by *shouldering*, as for the upper part of a lower rigging mat (when, after reaching the top of the dead-eye, it is contracted in order to cover the shroud for a few inches), you leave as many nettles out at each edge of the mat as will reduce it sufficiently, then lay the laniard (to secure the mat above the dead eye), along the top of the last turn of filling, and go on working on the centre nettles that you have retained, as far up as you intend to go. Knot the filling, tease the ends of the nettles out a bit, place them round the shroud and serve them over. The ends that you left out, on each side, you finish off by selvaging, as already explained. As the rigging stretches, turn the bottom of the mat up, with the end inside. Permanent coverings for laniards are not approved of.

Splicing a Sword Mat. Unlay six or eight inches of each mat, open the ends out, marry them together, lay one up and one down flat along the mat, withdraw the nettles on one side of one (No. 1) mat, and point the nettles of the other mat (No. 2) through the holes they came out of; all ends will then disappear from that side, and there will be four rows of ends on the other. Slue over, pick out the proper nettles of the side, which have been married together, withdraw the ends belonging to No. 2 mat, and introduce the corresponding ends of No. 1 through the holes. The same operation has now been performed on each mat, and on each side there are now two rows of ends; marry those together on each side, laying one up and

one down, and go on splicing by withdrawing and reeving, for two or three rows more in each mat. Leave off with the ends all out on the same side, and finish off with selvaging.

Cobbler's Stitch is used for joining the sides of mats together, Fig. 190, Plate 26. Take a filling of roping twine, middle it, and reeve each end through two bights in each mat (if a heavy mat, through three bights at each edge), then reeve the lowermost end back through the same bights as the upper end, which will bring the ends out at opposite sides; draw the mats together, and reeve both ends through two turns in each mat again, passing each other through the same hole opposite ways; and so work on, like a cobbler stitching a sole. Finish off each end, by taking a hitch through a bight in the mat of the next lay above, and cut the ends off.

Paunch Mat. For heavy-rigging mats, strands of 3-in. or 3 1/2-in. rounding would be used for foxes, with a laniard of 2 1/2-in. Stretch the laniard along at a convenient

working height, middle the foxes and lay them across it, and, commencing on the left, lay up one turn in the first pair, right-handed. Repeat this with the second pair, and lay up the nettle that comes round to the front and left, one turn with the underneath nettle of the first pair, which was brought out to the right; then lay this latter up, one turn with the other nettle of its own pair, and take a hitch with it-which do with the last two nettles on the left, each time that you work down to them, to keep the mat from unlaying again. Now commence with the third pair-take the underneath nettle round the upper one, which lay up with the underneath and right-hand nettle of the second pair, which lay up with the other one of the second pair, which lay up with the under one of the first pair, which lay up with the left-hand nettle of all, which lay up with two or three turns to prevent unlaying, round which take a hitch. So proceed until all the nettles are brought in-a second hand holding them back as you lay up, and when you have come to the last, and the full breadth of the mat is formed, go on in the same way, working down for length. When you have obtained this on the left edge of the mat, it will appear as in Fig. 191, Plate 26; and you then begin to work down square, taking a hitch with each pair as you have finished with them, to prevent them unlaying.

To selvage it, take it down, and lay it on a grating; commence with the first left-hand fox, which bring round under the next one, and lay up along the mat, laying the one that it comes round (which is the second fox) downward, and in this manner go right across; then stretch the laniard along the nettles where they cross, and hitch the ends to the grating. With the first fox laid upward take a right-hand hitch round the laniard, as in Fig. 192, and the first one down; then take the down one (a), dip it back under the laniard, and haul it taut down, another hand at the same time hauling back on the upper one, and so knot

the foxes right across. When done, haul all the lower ends taut up, and, beginning on the left cross the upper nettle (which is on the left of the lower) over it, and reeve it through the bight in the mat in the immediate lay to the right, bring the end out to the left (rove left-handed). Beat the hitches down, and cut the ends off, but not close; for if left of the proper length, they will form two rows of thrums. Tuck a thrum in every third bight up, and in every other lay across, which is quite thick enough; and_ beat down the bights in the mat that they are rove through, each time separately.

To Repair a Digging Mat which has had a hole chafed through it. Stick sufficient foxes through the bights of the mat at the top of the hole, to cover it, lying well over the edges, and back clear of the hole, and middle them. Bring the left-hand fox round the next one to it, lay

its end up, and the one it comes round downwards, like the commencement of selvaging; go right across and secure it by sticking the left-hand nettle, right-handed, through a bight in the mat in the edge of the hole, and the right-hand nettle, left-handed, through a similar bight, the ends of each pointing outwards; then work the next and succeeding rows as a paunch mat is worked, but working square across, laying one fox up with its next only, and securing each row as it is completed, by tucking the right and left-hand nettles in as you did with the first row. When you have thus covered the hole, stick all the ends through the bights below them left-handed once or twice, and cut them off; then slue the mat over, and either stick the broken ends into the new piece, or bring the edges together with a lacing.

Net-Making. Fill the needle, stretch the head-rope along, and begin on the left by securing the end of the twine to it. Regulate the size of the mesh by taking it over your finger, and then clove-hitching it to the head. When you have worked as far to the right as the head is intended to extend, get round on the other side of the net, and work back again; but this row of meshes, and all the subsequent ones, are formed by hitching them to the upper row with a sheet bend. When the second row is finished, shift round to the other side again, and work the third row. The last row is hitched to the foot-rope, which is weighted with leads; the head-rope is floated with corks; and side-ropes are afterwards seized on. Figs. 193 and 194, Plate 27.

To repair a seine, cut it away until you get a straight row of meshes, and replace them as at first made.

A Shot or Treasure-Net is made like a cabbage-net; the head-rope is circular, the meshes are formed in the usual way, and the circumference of the net is reduced as you work down, by bringing two meshes into one, at regular intervals; at first, one mesh in a row; in the next row, two meshes; then taking up every fourth mesh, next every third in a row, and so on. Finish off by working a small grommet through

the meshes at the bottom, to keep them together; and reeve two straps through the head for beackets, so that by hauling them apart, the mouth of the net is drawn up. Fig. 195, Plate 27.

Boats' Fenders. A paunch mat fender is made of a piece of mat rolled up taut, with the ends of the foxes placed in the centre; the end is sewed to the part of the mat where it terminates, and the edges are laced together. The laniard of the mat forms the laniard of the fender. Fig. 196, Plate 27.

The usual hanging-fender for boom-boats is made of as many parts of spun-yarn as will give it the requisite dimensions. These are middled and doubled over the laniard, and a small grommet is driven over the bights to make them snug, as in making a swab. It is then grafted over, either

Plate 27

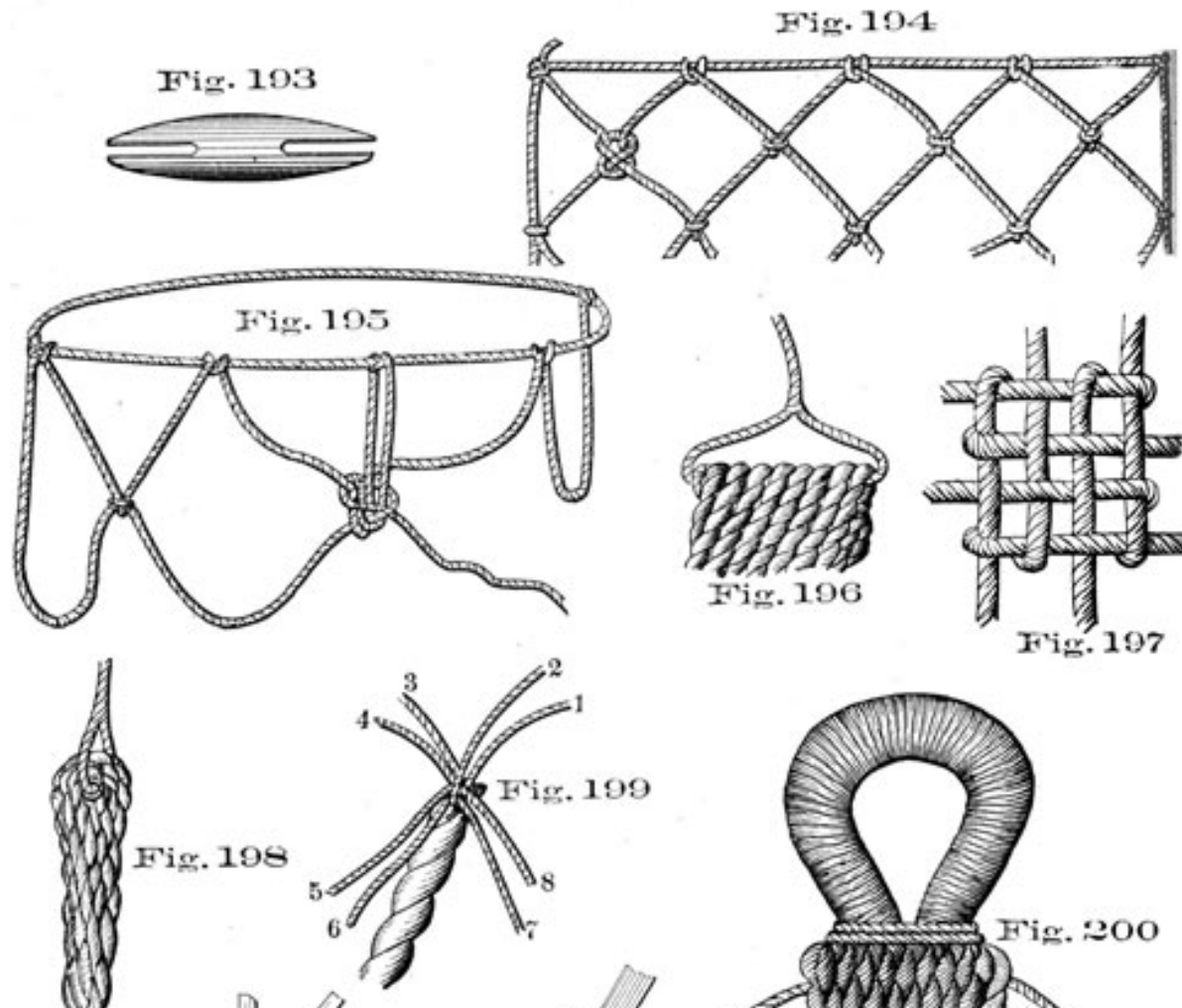


Fig. 201

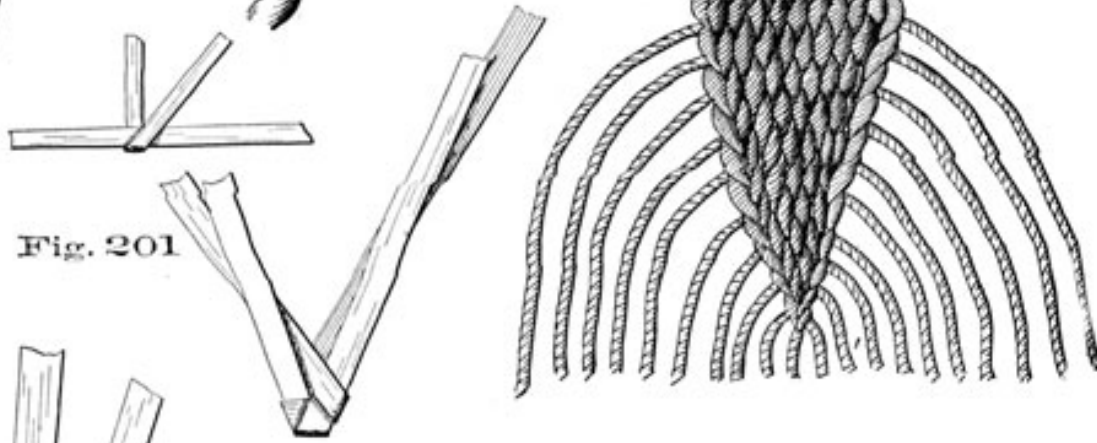


Fig. 202

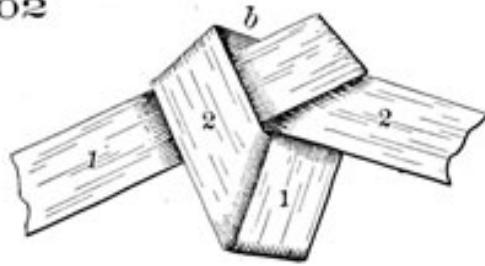
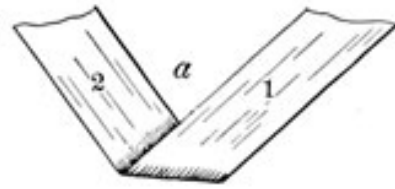
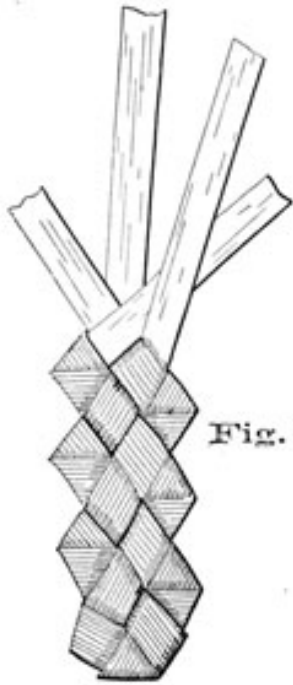
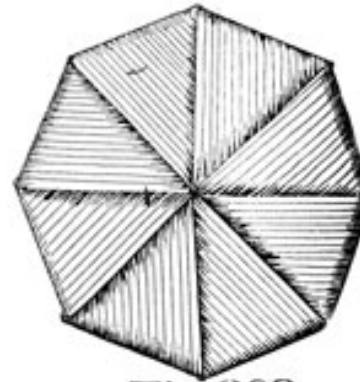


Fig. 203



with sennit or foxes, and finished off as grafting is usually finished; or by crowning the end over with the foxes. Figs. 197 and 198, Plate 27.

You can crown in this way with any number of ends that are a multiple of four, by dividing them into four parts, and laying a part down on each side; then bringing 1 over on side 6, keeping the bight up, laying 6 over between 1 and 2, bringing 2 over between 6 and 5, and laying 5 over outside 2; then laying 7 over 1, under 6, over 2, and under 5; 4 over 5, under 2, over 1, under 6; then reeving 8 across, and lastly 3;-when it will be found that all the ends are secured. Haul the bights taut down, and either put a whipping round underneath, or tuck the ends under the grafting and cut them off. Fig. 199, Plate 27.

A grommet fender is merely a rope grommet grafted over.

A canvas fender is stuffed with oakum, roped at the edges, and has a small grommet sewed on the centre, to keep the chafe off.

Leather fenders are used for gigs and cutters.

For another kind of fender for boom-boats, see DOLPHIN.

Hammock Clews. Take twelve lengths of nettle-stuff, middle them, serve round all at the centre, and pass a seizing to form the eye; then lay one up and one down, as for a sword mat, bring the outside nettle on each side across for filling, and leave it out; form the other rows in the same manner, and when reduced to two, knot the last pair. Fig. 200, Plate 27.

Spanish Clews are without plaiting, and are made by serving the nettles round below the seizing, leaving one out on each side, at regular intervals.

Sennit for Hats. Split the grass up, take a couple of lengths, cross one over the other, Fig. 201, double the underneath one over the upper, then the right-hand one over and under the other two, and what is now the right-hand one over two and under one, then the left-hand one over one and under two, and again the left over two and under one; then work two in on the right, and so on. Join the grass when you come to an end, by laying the end of another piece on the top, and then go on working it in; and always join on the upper side, because the under side is the proper *right* side of the sennit. Afterwards clip all the ends off, and rub the sennit down smooth with a bottle, or anything hard. Fig. 202.

The button is formed of a broader piece of grass (a). It is first doubled short over itself, then 1 under 2,- leaving a space, then 2 over 1, and down through the centre of the triangle; next 1 over 2, and down

through the centre, coming out on the opposite side, and so on until an octagonal figure is formed (b).

The hat is begun by stitching the sennit to the button, Fig. 203, commencing with the end finished off with, and

working round left-handed. The sennit is kept as slack as possible, and stitched through every other corner for the first few rounds; then afterwards through three thicknesses of sennit, and through every corner, the stitch being kept out of sight, by the needle being pointed underneath the strands of the sennit.

Coir Brushes. Shape a piece of hard wood for the back (stave of a salt-meat cask, for example), burn out the holes in rows with a marling-spike; and out of another piece of wood cut a *former*. Make the coir up into fillings proportionate to the size of the holes, pass the bight of the marline down through the first hole, slip it over the filling, take a turn or two round the former, and heave the bight of the filling through the hole, up to the level of the top of the back, Fig. 205; then slue over, put the filling between the notch of the former, and cut it off square, Fig. 204; dip the bight of the marline down through the next hole, and in the same manner proceed with each, until all are filled in.

To Mouse a Hook. This is done when hoisting a heavy weight to prevent the hook from straightening out, and on sails, &c., to prevent unhooking. Fig. 206, Plate 28.

Hogshead Slings. A piece of rope about five fathoms long, and from five to six inches in circumference, with a large thimble spliced in one end and the other end well whipped. They are used to sling large casks, being more secure than can-hooks. They are put on in this manner: pass the bight over one end of the cask, reeve the end through the thimble, and haul it well taut; then take the end round the other end of the cask, and take two half-hitches round the standing part, and it is done. Fig. 207, Plate 28.

Can-Hooks are broad, flat, iron hooks, in the eyes of which thimbles are inserted. Into these thimbles are spliced the ends of a piece of rope long enough to span a cask from chime to chime. The rope is then got on a stretch, wormed, parcelled, and served. A thimble is sometimes seized in the bight.

Some can-hooks are fitted with chain, with a large iron ring in the middle. Fig. 208, Plate 28.

Gun Slings are made of chain of three-quarter-inch iron, and tested to secure proper strength; the rings are of one and a quarter inch iron. The length of the slings should exceed by one foot that of the longest

gun on board. The two parts should be parcelled and marled together for a space of two feet before and one foot behind the trunnions of the longest gun, and a piece of three-inch rope spliced around both parts in the wake of the parcelling, long enough to take four or five turns round the chase of the largest gun.

Plate 28

Fig.204

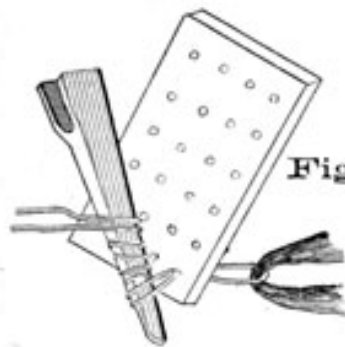
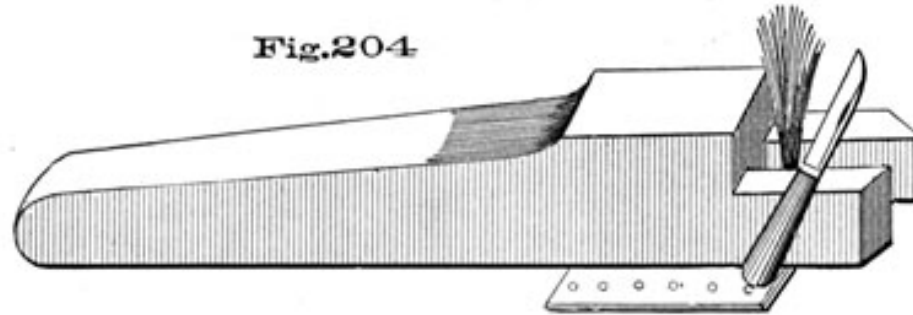


Fig.205



Fig.206

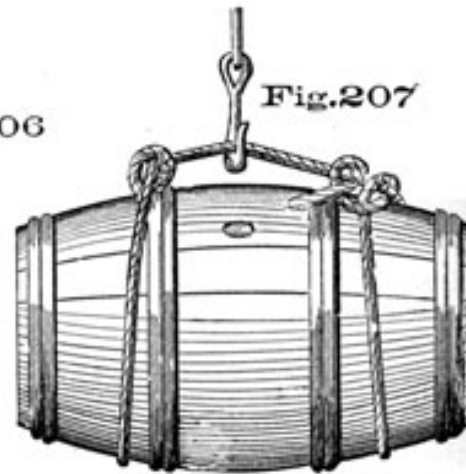


Fig.207



Fig.208

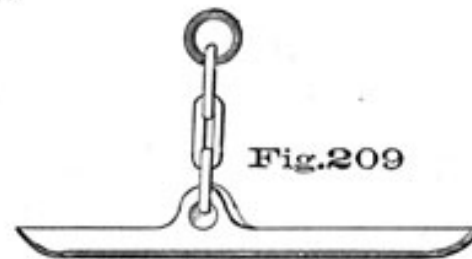


Fig.209

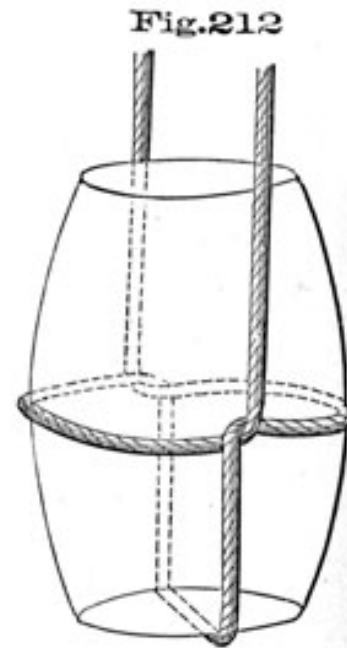
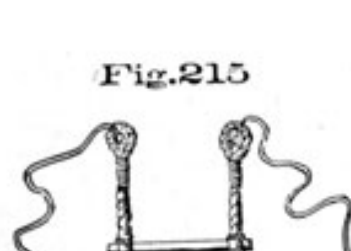
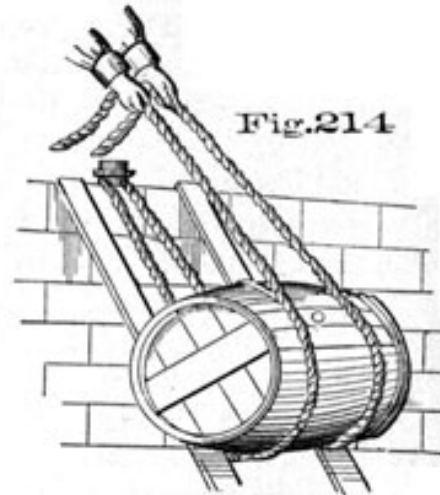
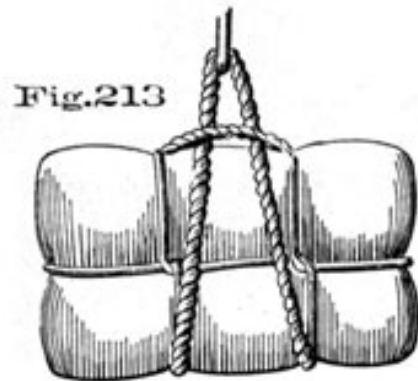


Plate 29



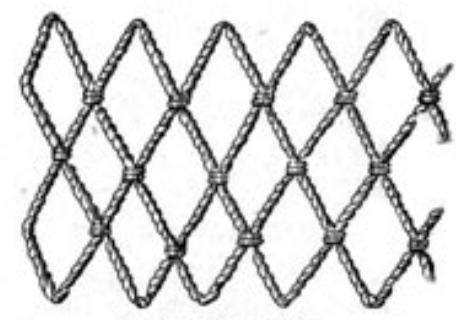
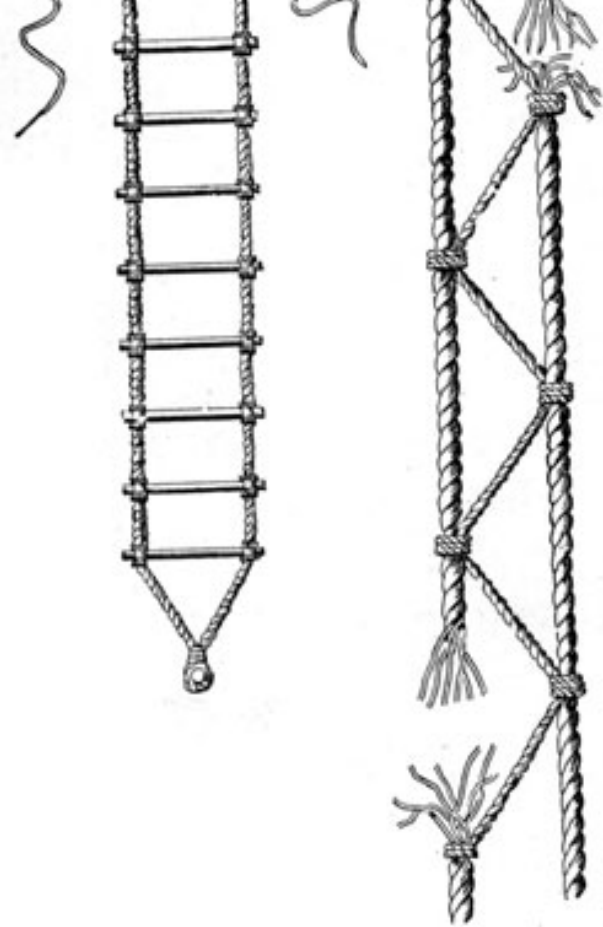


Fig.217



Fig.218

A Tank-Toggle, Fig. 209, Plate 28, is used when hoisting tanks. The toggle is put in the man-hole, and the yard tackle hooked to the ring. By the superior weight of one end, it is readily withdrawn. Small ones are convenient to use with empty casks.

To Sling a Cask with a Rope's-end-make a bowline knot in the yard-whip, and stick the end back so as to form a short bight, to which bend the stay-whip. Turn the bight of the bow-line over its own part, and slip each bight thus formed over one end of the cask. Fig. 210, Plate 28.

To Sling a Cask with the Head Knocked in-slip the bight of the whip under the cask, take a hitch with each part over the head, and knot them together above. Fig. 211, Plate 28.

Another way, though not quite so safe, is to make a figure-of-eight knot, and slip the bight under the barrel, as in Fig. 212.

Bale or Barrel Slings are generally made of three-inch rope, and of sufficient length to go round the bale or barrel. They are similar to a long strap, spliced together with a short splice; are passed round the barrel and one bight rove through the other. Fig. 213, Plate 29.

They are sometimes made long enough to sling two or three barrels at a time.

A Parbuckle, Fig. 214, Plate 29, is a purchase contrived with a single rope for raising a heavy cask or other similar weight. The same kind of purchase, though on a larger scale, is used for getting on board the sheer legs when masting a ship with one's own resources.

JACOB'S LADDERS, ETC.

Jacob's Ladders are made of rope, as in Fig. 215, Plate 29, for convenience of passing into the boats, into the rigging, &c. They lead from the spar deck to the lower rigging, to enable the topmen to get in the rigging without getting on the hammocks; on the lower booms and main brace bumpkin to facilitate getting in and out of boats; and in large ships, to the after-end of the spare topsail yard in the chains; and also from the top-gallant mastheads, the lower end setting up to the afterpart of the cross-trees.

Take twice the length, of four-stranded rope, the ladder is to be, and seize a thimble in the bight, having first wormed the rope; then at equal intervals, say sixteen inches, places the "*rounds*" or rungs between the strands, working Turk's heads on each side; splice a thimble in each end, and splice a lanyard in the thimble. Those for the lower

boom, stern, and rigging generally, have sister hooks, and hook into eye-bolts placed for the purpose.

Formerly a small line was rove through holes made in the centre of the rounds and ran the entire length of the ladder, and was called a *concluding line*.

Snaking on Backstays, &c. Seizing a small rope alternately from one stay to another, to keep either from falling if shot away. This is only done when preparing for action. Fig. 216, Plate 29.

NETTINGS.

Netting, Fig. 217, Plate 29, are made by seizing together the bights of small ropes-such as ratline stuff-leaving uniform spaces or meshes between. The rope is first marked off at equal intervals with chalk, and neat seizings of twine clapped on. They are used in different parts of the ship for various purposes.

Jib Nettings seize to the jib guys on each side, passing under the boom, and are for the purpose of catching and holding the jib when hauled down, and to save men from falling overboard when stowing the jib in bad weather.

Staysail Netting, for stowing the foretopmast staysail in.

Boarding Nettings trice up from the rail to the ridge-rope to prevent the enemy from boarding. These, when made of ratline stuff well soaked in tar, sanded, and allowed. to harden, defy the sharpest knife.

Quarter-deck nettings are stretched over the deck like an awning to prevent spars, &c., from falling on the heads of the officers in time of action.

Boarding and splinter nettings as well as exterior nettings for defence against torpedoes are only furnished in time of war.

Plate 30

Fig.221

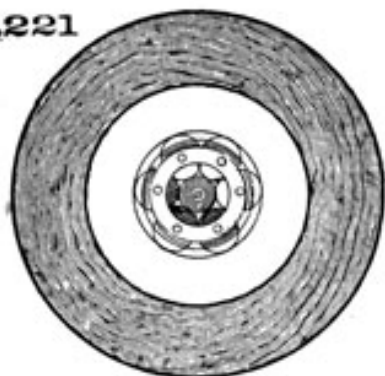


Fig.220

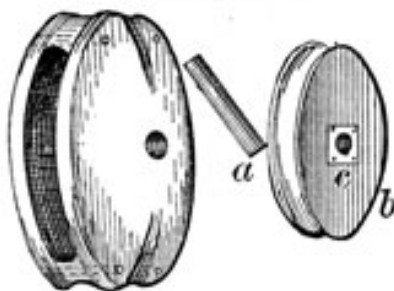


Fig.231

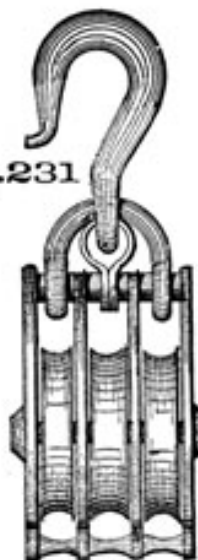


Fig.222



Fig.223



Fig.224

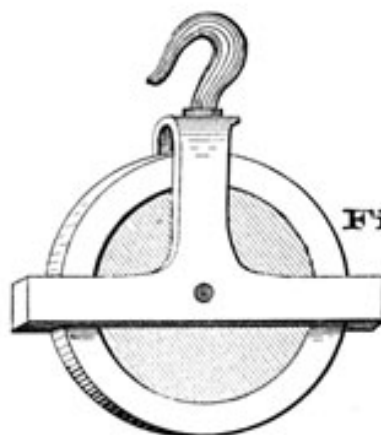


Fig.226



Fig.228



Fig.230



Fig.227

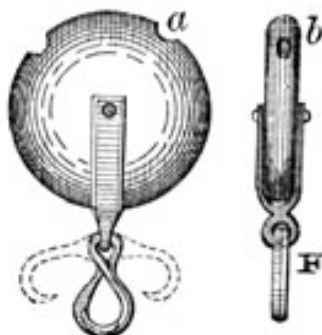
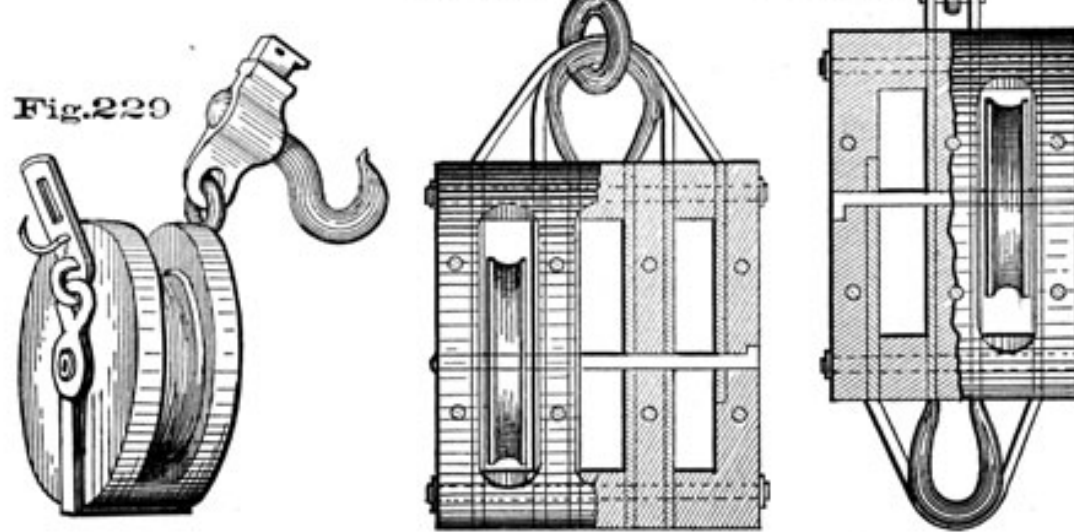


Fig.225



Fig.232





CHAPTER V.

BLOCKS.

Blocks are mechanical contrivances, possessing the properties and powers of pulleys. They are generally made by machinery, of ash, and are, what are called, *made* or *mortised*.

The made block, Fig. 220, Plate 30, consists of four principal parts, as follows:-The *shell* or outside, consisting of two or more pieces pinned together; the *sheave* or wheel. (b), over which the rope passes; the *pin* or axle (a), on which the sheave turns, and the strap, either rope or iron, which encircles the whole, and by which it is confined to its particular place.

The sheave may be of metal or of lignum-vitae; if the latter, it is *bouched* (c), in all blocks except those used for the gun tackles. In the patent blocks the bouching contains *friction rollers*. Fig. 221.

In the common block the bouching is counter-sunk, and made of a composition of 100 parts of copper and 16 of tin. The sheaves of blocks used for gun tackles are not allowed to be bouched, and the pins are made of hardened copper. The pin of the common block is made of iron.

Mortised blocks, Fig. 222, Plate 30, are made from a single piece of wood, mortised out to receive the sheave.

Blocks are single, double, treble or threefold, and fourfold, according to the number of sheaves contained within the shell; are either single or double *scored*, and are measured by their length-that is, the length of the shell.

The *scores* are the notches cut at the ends of the shell to admit the strap.

The sizes of blocks used in the navy range from 4 inches to 22 inches inclusive, as follows:-4-inch, 5-inch, 6, 7, 8, 9, 10, 11, 12, 14, 16, 18, 20, and 22, single and double of each size, and treble blocks for the largest purchases.

Not included in the above are viol blocks, large blocks used for warping, &c.

Blocks take their name from the purposes to which they are applied, or from some peculiarity of form, the following being the principal ones in common use:-

Bee-Blocks, or simply BEES, are thick pieces of oak bolted to the sides of the bowsprit, having heavy metal sheaves in them for the fore-topmast and fore-topmast spring stays to reeve through.

64

Cat-Block, a large, double or three-fold block, iron-strapped and composition sheaves. It has a large hook connected with the strap by a link, to admit play. It is used to raise the anchor to the cathead. Fig. 225.

Cheek-Blocks are made of a half-shell, and bolt against a mast or spar, which acts as the other *cheek* or half of shell. The chief bolt serves as a pin for the sheave to turn on. Used on gaffs for brails, &c.

Clew-garnet Blocks are single, iron-bound, and hook or shackle to the iron bands on the quarters of the fore and main yard. They hang under the yard and receive the clew-garnets, by which the courses are hauled up. The name also applies to the blocks which hook in the clews of the sail.

Clew-line Blocks are those which are attached to the clews of the topsails for the clew-lines. Formerly, the name applied only to the block on the yard, now called QUARTER-BLOCK.

Clump-Block. Strongly made blocks with a thick metal sheave, having a large swallow or opening in proportion to the length. Used for the topsail and topgallant lifts in the top; also on collar of main stay for fore-topsail brace, &c.

The same name is applied to any short thick block, such as fore and main tack blocks, &c.

Dasher-Block is the small block sometimes strapped to the extremity of the spanker-gaff, for reeving the ensign halliards.

Euphroe. A long piece of wood having a number of holes in it, through which the *crow foot* for the awnings is rove. It has a score around it for a strap, and is strapped with a thimble for bending the crow-foot halliards.

Fish-Block. For fishing the anchor; a large double or treble block, iron strapped, fitted with several links of chain and a hook to hook on the arm of the anchor.

Fiddle-Blocks, Fig. 223, Plate 30, are made with a long shell so as to have one sheave over the other, the lower being smaller. Used for top-burtons and as *hanging blocks*. When used for fore or main buntlines the two parts are connected by a swivel.

Fly-Block is the upper block of the topsail halliards. It is double, has sister hooks and thimble for hooking to the topsail tye. Friction rollers.

Gin-Blocks, Fig. 224, Plate 30, are large composition sheaves which turn in a metal framework. Used principally for topsail tyes, and hook to iron bands, made to fit snugly over the topmast tressle-trees. The name is also applied to the small metal blocks used aloft for various purposes, such as for topgallant and royal braces, topgallant buntlines, etc.

Girt-line Blocks are single, through which girt-lines, or single whips reeve, as the mast-head girtlines, in rigging ship, etc. Sometimes called *gantlines*.

Hanging-Blocks. Any block depending at a mast-head, as a lead for running rigging; such as the fiddle-blocks at fore-topmast head for head halliards and topsail buntlines, etc.

Jack-Blocks are large single blocks, used for sending up and down topgallant and royal yards.

Jeer-Blocks are large double or treble blocks for reeving the purchases for sending up and down the lower yards.

Jewel-Blocks are single blocks at the extremities of the topsail, topgallant, and sometimes, though rarely, royal yards, through which the studding-sail halliards reeve. The head of the studding-sail, when set, is hoisted to them.

Main-sheet Block is a double or treble block, strapped to the main-boom of a schooner or sloop, for the main-sheet, or a single block for main-sheet of square riggers.

Quarter-Blocks, on the topsail or topgallant yards, are double, and are iron-strapped to the quarters of the yards, to give lead to the sheet of the sail above and clewline of the sail below. On the lower yard they are single, for the topsail sheet alone, and on the royal yard they are single, for the royal clewline alone. Those for the topgallant and royal yards go with sister hooks, that they may be readily detached.

Sister-Blocks, Fig. 226, Plate 30, are formed of one solid piece and two sheaves, one above the other; between the sheaves is a score for a middle seizing, and on the sides a score for the shrouds to fit in. They are seized between the two forward shrouds of topmast rigging, and give lead to the topsail lift and topsail reef tackle, Fig. 270, Plate 38. Frequently, of late, the reef tackle is given a different lead, in which case but one sheave is seized in.

Secret-Blocks, Fig. 227, Plate 30, are so made that the sheave is entirely screened, the rope leading through an orifice in the shell just large enough to admit its free passage, the object being to prevent its fouling by small gear catching in the swallow and choking it. Used for clewlines, which are frequently fouled by reef-points, and for clew-jiggers. The shell of the block, Fig. 227 (a and b), is made of lignum-vitae, and has an iron half-strap. The hooks fitted to this block are known as *clip* hooks. Similar hooks are shown in Fig. 228, but opening *perpendicular* to the sheave instead of opening *in line* with it. Hooks fitted as in Fig. 228 are known as *sister* hooks.

left open, and the strap at that part fitted with a clamp, so that the bight of a rope may be "*snatched*."

Telegraph-Blocks are pyramidal shaped blocks, with a number of small brass sheaves, used for making telegraphic signals.

Top-Blocks, Fig. 233, Plate 31, are large, single, iron-bound blocks, used for sending up and down topmasts. They hook to an eye-bolt in the lower cap, hooking from *in*, *out*, so that the *bill* of the hook points outward, and the top pendants reeve through them. Sometimes shackled.

Topgallant-top Block is similar to the above, but smaller. It is used for the topgallant-mast rope, and hooks from *in*, *out*, to an eyebolt in the topmast cap.

Tye-Blocks are large, single, iron-bound blocks, which bolt or shackle to iron bands on the topsail yard, for the topsail tyes to reeve through.

Viol-Blocks are large single blocks, with a swallow large enough to take a small hawser.

In the navy-yards there are fourfold blocks of 30 inches and over, for heavy purchases.

Block-and-Bock, or "*two blocks*," is the term applied to a tackle when its two blocks are drawn so close together that they cease to operate. The act of drawing the blocks apart is called *fleeting the purchase*, or *overhauling it*.

Blocks should frequently be examined, not only as to strapping, but also by knocking the pin out and inspecting the bouching. The loss of power, and strain on rope, occasioned by a worn bouch, is considerable. The working blocks of tackles (for instance, the fly block of topsail halliards) are always more worn than the lower ones, and, therefore, without waiting until the sheaves *shriek* and become *dumb*, the blocks should be shifted and the sheaves transposed. This remark applies also to quarter-davit blocks.

The sheave, on which the hauling part of the rope works, does most duty; and this calls for greater

strength, and frequent alterations in upper blocks.

All blocks which stand horizontally must be placed with the square end of the pin upwards: as, when the shell shrinks, it is liable to fall out if placed otherwise.

Hanging, Tye, and Quarter-Blocks, undergo great strains when bracing sharp up; if the former are *two blocks*, the weather halliards should be eased up sufficiently.

Hooks. There is no proportion for hooks, so that while handling heavy weights, unless the hooks be evidently very strong, it is safer to use a shackle or a good mousing. More accidents happen from open hooks than from chain or cordage. Great support may be given a hook by slipping a link or a shackle over the point, Fig. 234, Plate 31.

Thimbles are made both perfectly round, and also,

Plate 31

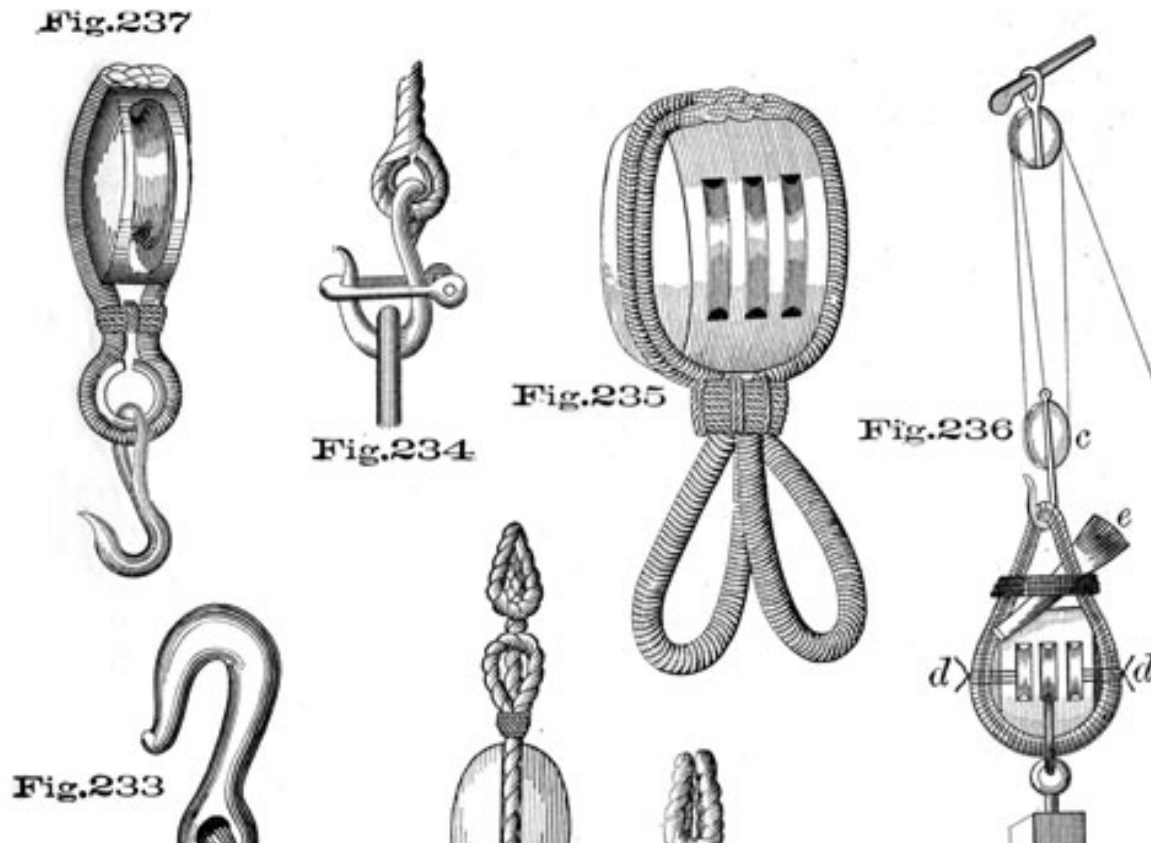




Fig. 238



Fig. 239

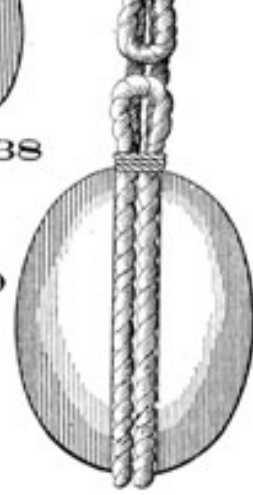


Fig. 242

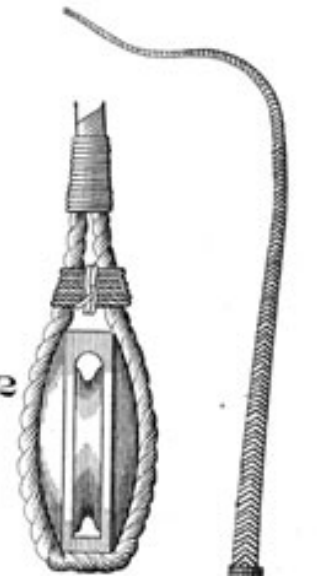


Fig. 240a

Fig. 240b

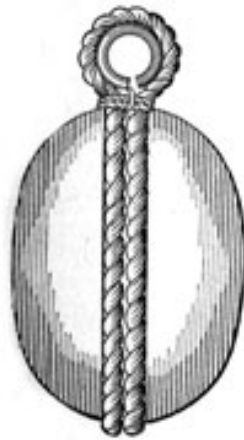


Fig. 241d

Fig. 241c



Fig. 243

with the ends nearly joined. Two are sometimes united for the purpose of giving easy play to the adjoining straps or block, as well as a different stand. These are called LOCK-THIMBLES.

STRAPPING BLOCKS.

The majority of the largest blocks supplied to men-of-war are iron-strapped; quarter-blocks, brace-blocks, clew-garnet-blocks, top-blocks, cat-blocks, blocks for boat falls, and many others are of this class. All the above, except the cat-blocks and top-blocks, are also provided with friction rollers, and the same may be said of nearly all iron-strapped blocks which are not subjected to very heavy strains. Some blocks are made entirely of iron, such as the jeer-blocks for small vessels, secured permanently in the chain sling. See also Fig. 231, for a treble iron block.

Figs. 229 and 233 show one method of strapping blocks with iron. Another plan is to use inside iron straps, as in Figs. 230 and 232, which are probably the strongest straps yet devised.

When not iron-strapped, blocks are fitted with straps of hemp or wire-rope.

A wire-rope strap differs from a hemp one in being wormed, parcelled and served, and in being usually made of rope one half the size of the corresponding hemp strap. In wire straps for ordinary single blocks, the splice comes on the side instead of the breech, to avoid a nip near the splice.

Hemp-rope for block-straps should be well-stretched, or until it begins to look "long-jawed," that is, the angle of the lay diminished.

The common but rather rough rule for the size is, that the rope for the *strap should be in circumference one third the length of the block*, increasing the size for the straps of heavy purchase blocks; and the old rule requiring the *block to be in length three times the size of the rope* it reeves, brings the rope reeving and the strap about the same size.

Once and a half the round of the block gives a good measure for the common strap, in which the two ends are joined by a short splice; first reeving the ends through the eye of the hook; a seizing of marline, houseline, spun-yarn, hambroline, or larger stuff, according to the size of the block, is then clapped on between the thimble and the block.

The splice should be placed at the breech of the block. After getting a good strain on the strap, the splicing ends may be trimmed off.

if they are much exposed, as they decay more rapidly, and break without warning.

To preserve straps from chafe, however, as in the case of purchase-blocks, they are either served or covered with canvas or leather.

All blocks below twelve inches should be measured for straps with a piece of spun-yarn, around the block, in the *score*; and those above twelve inches, with a piece of small stuff, such as 6, 9, 12, or 15-thread ratline, in the same manner, as the size of the strap increases.

A Threefold Block Strap. Large blocks for heavy work, such as the main purchase of masting sheers, &c., are strapped with eyes for toggling, as in Fig. 235, Plate 31.

These blocks, being so unwieldy, require a purchase to heave the strap out, and a wedge, or large fid, to fix it in. When this block is strapped on board merchant ships, it is generally done in a vertical direction; reeving a rope through one of the sheave-holes, and making it fast to a ring-bolt, &c.; then hooking a stay tackle (c), Fig. 236, to the two bights of the strap, and setting it taut. A frapping, or temporary seizing, is next put on above the block, and hove well taut by a heaver. A large fid (e) is driven in betwixt the head and the frapping, and a stop of spun-yarn (d-which is too low down in the plate) is clapped on; being rove through the *upper* part of the sheave-hole on each side, and nippered round the strap with a heaver, which keeps it in its place. The fid is then knocked out, the frapping taken off, and the seizing clapped on as before. In men-of-war, when these blocks are strapped, they use a chock, instead of a fid, and a wedge is driven in between the chock and the block. The nipper (d) is taken round both the strap and block, and hove taut with a heaver.

A Grommet-strap. Measure with a rope-yarn the *neat* round of the block, and the thimble, the latter placed at the proper distance from the end of the block. With this measure of rope-yarn, lay off on the rope intended for the strap (having previously got it on a stretch) three lengths from the end, marking each one distinctly, with chalk, and cut a little beyond the last mark, to allow for sticking the ends. Unlay the strand, bring the first and second chalk marks together, lay up the grommet and stick the ends. If well made, the grommet will lie flat on the deck. Before forming the grommet, the end must be rove through the eye of the hook. Get it on a stretch; worm, parcel and serve-cover with canvas, leather or point, as required; pass the seizing of marline, spunyarn, or small stuff, according to the size. These seizings are

always crossed. This makes a neater strap than one which is spliced.

A Common Strap, Fig. 237, Plate 31. First,

cut the rope once and a half the round of the block, get it on a stretch; worm, parcel and serve as near the end as possible, not to interfere with splicing; then splice the ends together with a short splice, and finish serving snug up to the splice. Stretch it and cut the ends off, or you may serve over the ends. If there are a number of these straps required, it would be best to get the rope on a stretch, and serve off the required number before cutting.

The Single Strap, with Lashing Eyes. Besides being fitted with hook and thimble, the single strap may be fitted with lashing eyes, as in the case of jewel-blocks, &c. when they are made as in Fig. 238, Plate 31.

The Double Strap, Figs. 239 and 240, *a* and *b*, Plate 31. When strapping large blocks, requiring considerable strength, as in heavy purchases, or when a certain lead is required, the double strap is used, which is simply a single strap of twice the usual length, doubled.

The double strap may be fitted with the thimble only, Fig. 240, with the hook and thimble, or with lashing eyes, Fig. 239.

The leading blocks at the fife-rail are strapped, as in Fig. 240, the thimble playing on a thwartship-rod of iron, otherwise they would not give the fore-and-aft lead.

The Two Single Straps, Fig. 241. It may happen that the double strap will not give the block the desired lead, in which case two single straps are used.

When not iron-strapped, the tye-blocks on the topsail-yards are fitted as in Fig. 241 (a), Plate 31, with lashing eyes.

The same strap is required for jeer blocks when rope strapped, to give a fore-and-aft lead.

Strap and Pendant. When a single block is strapped with a pendant, an eye is spliced in the latter much larger than the circumference of the block, and a good seizing, is then hove on as in Fig. 242.

Tail-blocks, Fig. 243, Plate 31, are used for single whips, and, generally, whenever a single block is used temporarily. A piece of rope may be spliced around a block, leaving a long tail with the end whipped, or may be unlaid and plaited, as in the figure. Such a block is used in the main rigging for the fore topmast studding-sail tack, and a double one when the boom-brace is used. Sometimes the yarns of the tail are merely opened out and marled down, selvagee fashion.

The double block of a jigger is often strapped with *two* such tails, and called by sailors a *handy billy*. This is very convenient for clapping on anywhere, as when getting the topsail sheets close home. &c. Fig. 264, Plate 35.

Rules for Cutting and Fitting all the usual kinds of hemp straps will be found in Appendix B.

CHAPTER VI.

TACKLES.

A **Tackle** is an assemblage of ropes and blocks, and is known in mechanics as a system of pulleys.

The simplest contrivance of this kind is the single whip, or girtline, which consists of a rope rove through a single *stationary block*. By this arrangement, a better lead is given the rope, *but no power is gained by it*.

But this arrangement is extremely convenient and often absolutely necessary, as in hoisting articles from the holds to the upper decks, or from the decks to the masts and yards.

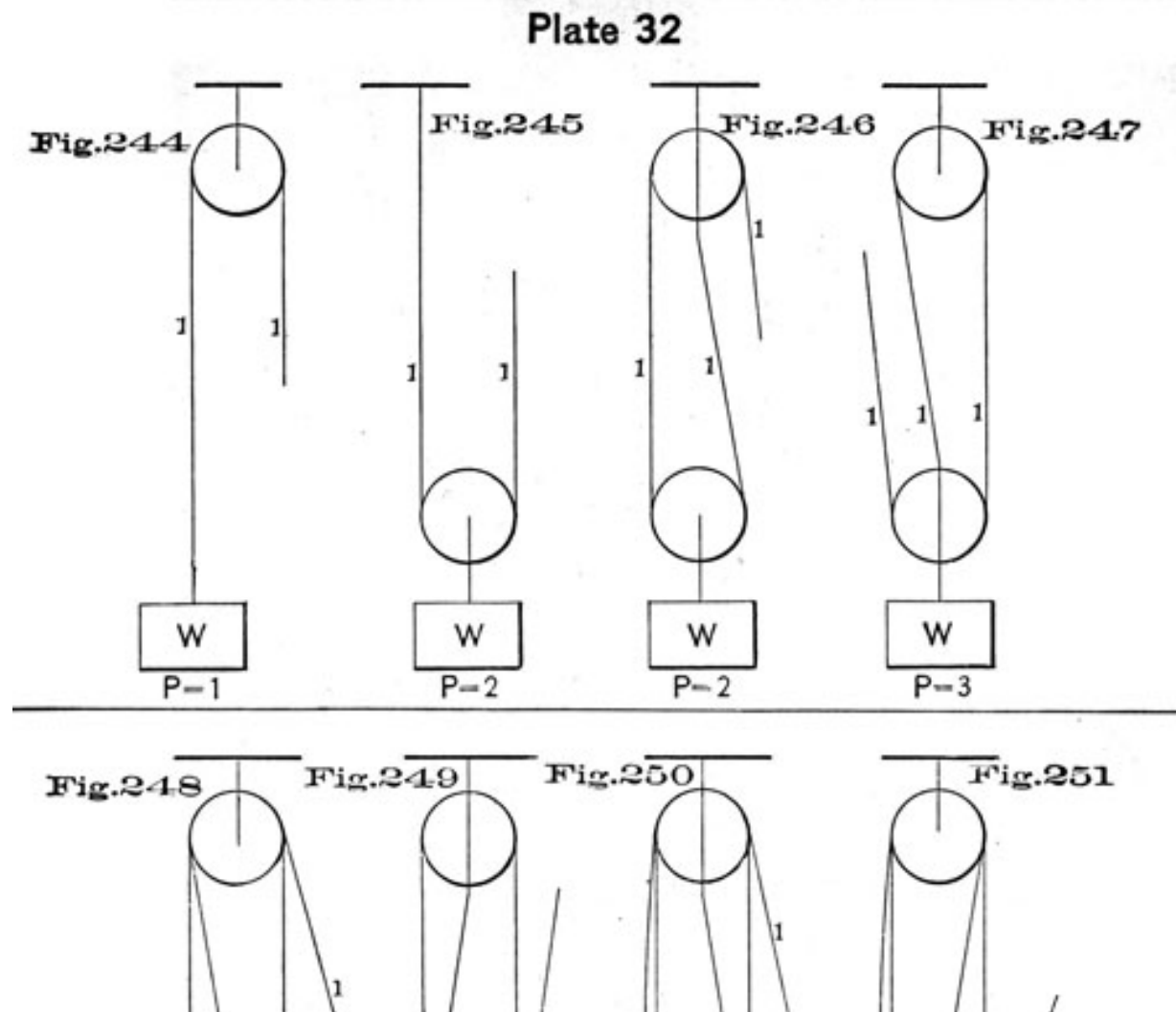
It is quite different, however, when the single block is movable, or attached to the weight to be moved, and generally these two principles obtain in all tackles, namely, that *stationary blocks give no gain*, but only serve as a lead to the rope, and *all increase of power is derived from movable blocks*.

The block having the greatest number of parts of the fall should be attached to the weight to be moved, in order to gain the greatest mechanical advantage. The power gained is equal to the number of parts at the movable block.

As, in all purchases, a considerable proportion of power is expended in overcoming friction alone, and as stationary blocks, while they serve to augment friction, yield no mechanical advantage, *there should be as many movable blocks as possible*.

To Determine the Relation of Power to Weight in any system of pulleys, we have to remember that the tension on a rope is the same throughout, from the point hauled on to that at which it is made fast, friction not considered. If we then make a figure of a system of pulleys, tracing up the tension on each part, marking the hauling part as 1, we find the purchase by adding the values thus assigned to each part of rope at the weight, or reeving through the block at the weight. When the rope itself starts with a doubled power as at A, Fig. 253, each part of such a rope must be marked 2; if it starts with a quadrupled power as at B, Fig. 255, each part must be marked 4, &c.

Plate 32 shows the manner of estimating the power in this way, with the forms of purchase in ordinary use.



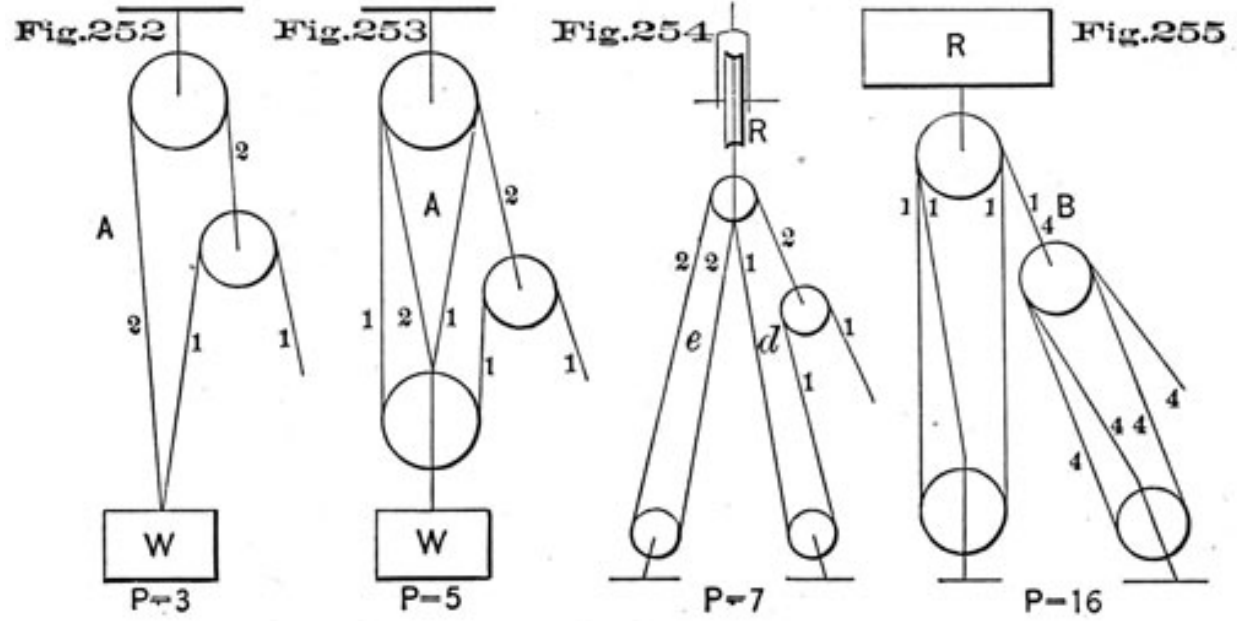
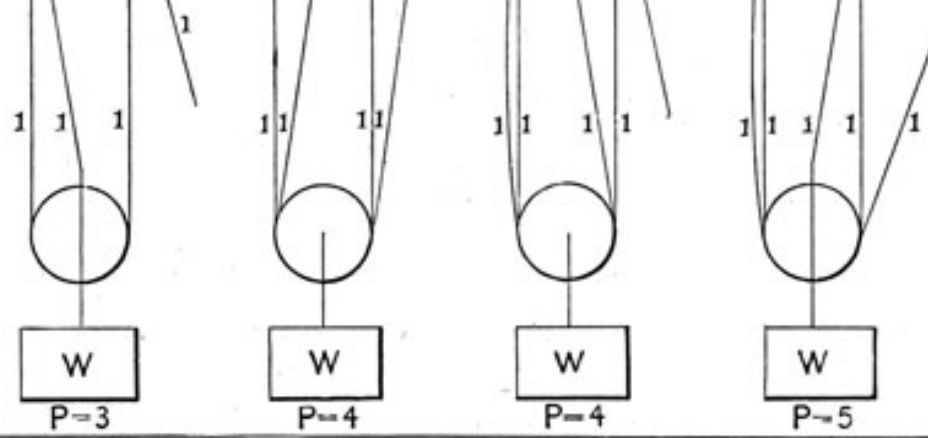


Fig. 244, Single whip; power gained, none.
Fig. 245, The same with block at the weight; power gained, 2.
Fig. 246, Gun tackle, purchase, power gained, 2.
Fig. 247, The same inverted, power gained, 3.
Fig. 248, A luff tackle, power gained, 3.
Fig. 249, The same inverted, power gained, 4.
Fig. 250, Double purchase, power gained, 4.
Fig. 251, The same inverted, power gained, 5.
Fig. 252, Single Spanish burton, power gained, 3.
Fig. 253, Double Spanish burton, power gained, 5.
Fig. 254, Bell purchase, for topsail halliards, power gained, 7.
Fig. 255, Luff upon luff, power gained, 16.

In the above estimate for Bell purchase, the angle between the two parts, *C, D*, should be considered.

The general rule for ascertaining the power necessary to raise a given weight with a tackle, is to *divide the weight to be raised by the number of parts of rope at the movable block or blocks*, the quotient being the power required to produce an equilibrium, friction not considered.

To ascertain the amount of purchase required to raise a given weight with a given power, divide the weight by the power, and the quotient will be the number of parts of rope which must be attached to the lower block.

To ascertain what weight given tackling will raise, the weight a single rope will bear is multiplied by the number of parts at the moving block.

When one tackle is put upon another, multiply the two powers together to get the total amount of purchase gained. Thus with a luff tackle, with four parts at the movable block, the gain is four. A luff upon luff would give an increase of 16 times, another luff clapped on to the fall of the second, 16×4 , or 64 times, &c.

These rules require considerable modification for friction.

Power can only be increased at the expense of time, hence there are many cases on board ship where a great deal of purchase would be a positive disadvantage. Were treble-blocks used for the side tackles of a broadside gun, the gun could be run out more easily than with a double and a single block, but then it would be longer in running out, and there would be an inconvenient accumulation of fall.

The tackles of a broadside gun furnish a good illustration of the relative advantages of the stationary and movable blocks. The train tackle, as ordinarily hooked, yields the greatest advantage for running the gun in. If, through inadvertence, the blocks were reversed, the effort would be applied to rouse the train bolt out of the deck, rather than to run the gun in. The side tackle is necessarily hooked so

as to afford the least mechanical advantage, in order to give a proper lead to the fall.

Friction. Perhaps we shall not be far wrong if we estimate *one sixth of the original force* to be consumed by friction each time the rope passes round a sheave. Thus, supposing the tension or strain on the hauling part be 6, that on the next will be 5, the next 4, the next 3, and so on. So that if the strain on the fall of a two-fold tackle be 6, the strains on the parts of the rope will be represented by the figures 6, 5, 4, 3, and their sum, 18, will nearly represent the power of the tackle, instead of 24, which it would have been had there been no friction; or about one fourth of the force would have been consumed by it.

If the rope which passes round the sheave of the block be small, it will be more flexible; a less force will be necessary to "nip" it round the sheave, and there will be less resistance by friction against the inside of the shell of the block.

From these considerations, we gather that work is lightened by using *large blocks and small ropes*; the boatswain's rule, that the hauling part of a fall bears double the strain of the standing part, is not far wrong; that as the pin of a block is more worn on one of its sides, it should be frequently turned; and that as sheaves nearest the standing part do least duty, they should be shifted occasionally with the others.

There are about five different purchases in common use, viz.:

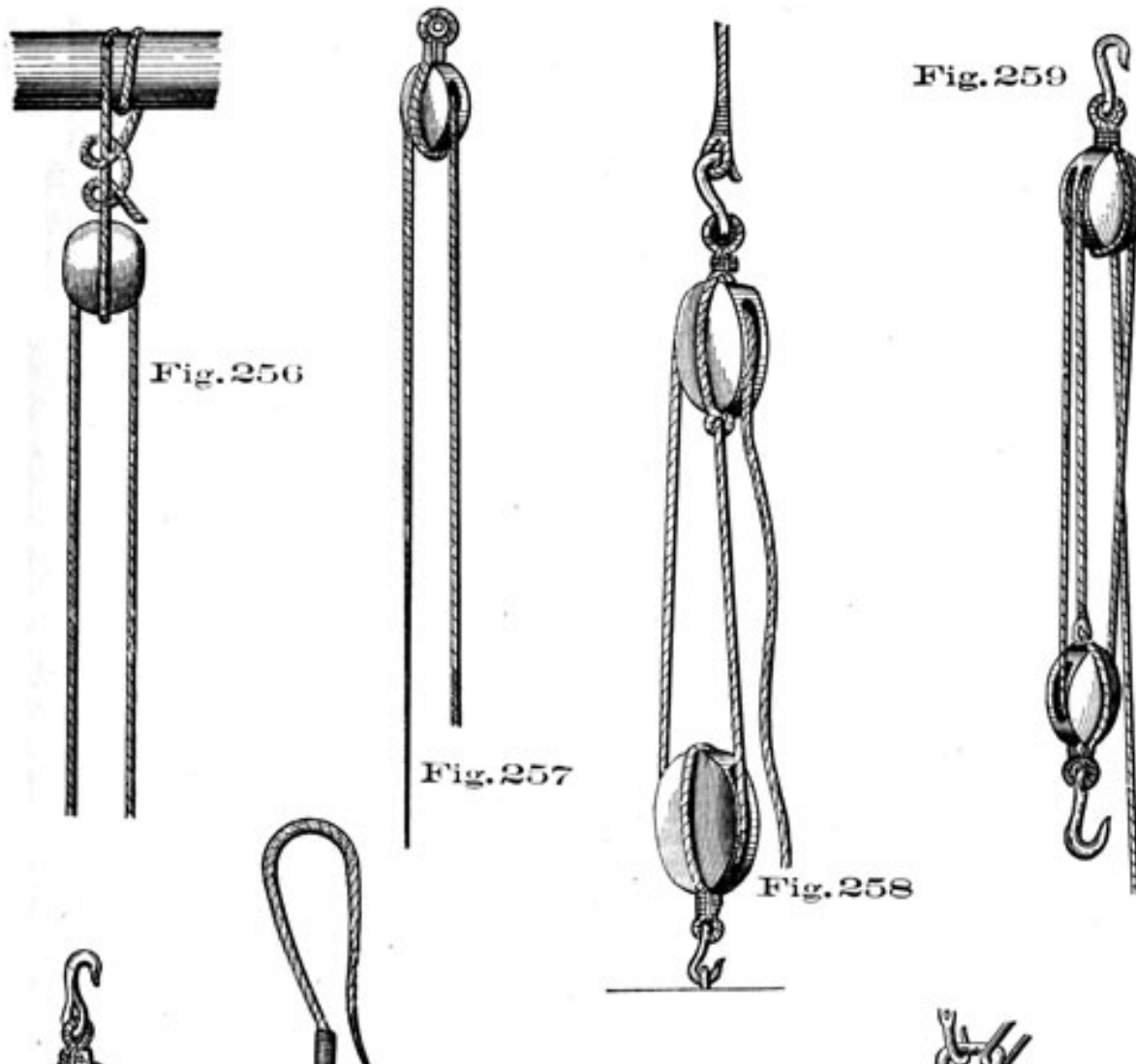
A Single Whip, Fig. 256, Plate 33, which consists of a single stationary block and fall. By it the power can be more conveniently applied to the weight, but no power is gained. It is therefore, in reality, no purchase at all. The term whip is sometimes applied to tackles, as the *water-whips*.

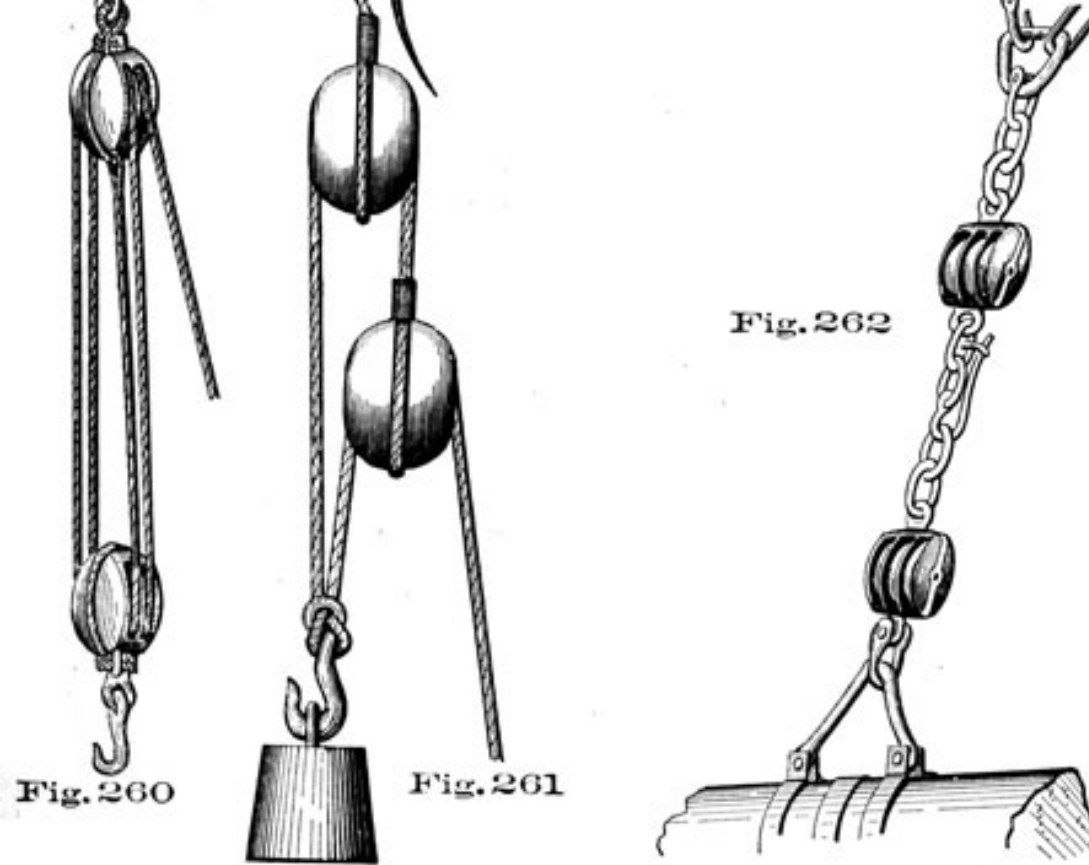
A Runner, Fig. 257, Plate 33, a single movable block and fall. In this case, the fall is called the runner, and has a thimble spliced in the end, for hooking a purchase to. By it the power is doubled. The main bowline and topsail tyes are instances of runners. Runners, as in the figure, are used for setting up backstays, and generally wherever they can be applied to advantage.

A Gun Tackle Purchase, Fig. 258, Plate 33, is composed of two single blocks, strapped with hook and thimble, the standing part of the fall bent to the becket, or spliced into the strap of the block from which the fall leads. The advantage derived from this purchase has been given already. Its gain is as 1 to 3.

A Luff Tackle, Fig. 259, Plate 33, consists of a double and single block, each strapped with a hook and thimble, the standing part of fall bent to the becket, or spliced into the strap of the single block. If the double

Plate 33





block is hooked to the weight, the power is multiplied four times; if the single block, then but three times, &c.

A Twofold Purchase, Fig. 260, Plate 33, consists of two double blocks, the standing and hauling part leading from the same block, and *on opposite sides*, so that the block will not cant. The power gained is four or five times, as it may be applied.

A Threefold Purchase consists of two treble blocks, having the fall and standing part leading from the same block, and from opposite sides. Its power is six or seven times.

The foregoing are the principal kinds of purchase in use on board ship; all others are combinations or modifications of these, and take their names from the purpose for which or place where used, the following being those in most general use.

Boom Tackle, or boom-jiggers, used in large ships for rigging in and out the studding-sail booms. In schooners, the tackle which guys the main boom forward, when going large.

Burtons are light tackles. The term *burton* by itself, is generally understood to apply to those which are nearly always kept hooked to the pendants, at the topmast heads, ready for use, and called *top burtons*. They are the same purchase as a luff, but instead of the common double block like a luff, it has a fiddle block, both for neatness and convenience, there being but little room close up under the eyes of the topmast rigging. The falls of these burtons are long enough to permit both the lower block and hauling end to reach the deck, with plenty to spare, while the upper block is hooked to the topmast pendant.

Spanish Burtons are of various styles.

A single Spanish burton, Fig. 261, Plate 33, consists of two single blocks, the standing part spliced in to the strap of the movable block and the bight seized or bent to the hook. This increases the power three times.

The double Spanish burton, Fig. 253, Plate 32, has one double and two single blocks the standing part spliced in the strap of one single block, then rove through the double or fixed block, and the bight seized to the strap of the lower block, to which the weight to be lifted is hooked. The end is then rove up through the double block, through the lower and lastly through the single block to which the standing part is secured. This purchase gives an increase of five times the power applied. Figure 254, Bell's purchase, increases the power seven times.*

A Deck Tackle is a heavy purchase, of a double and single, or two double blocks. It is used for rousing in chains, and for heavy work generally.

* See also Bell's purchase, and Plate, Chapter IX., HALLIARDS.

Fish Tackle is a heavy purchase of double or treble blocks, used for fishing the anchor; that is, for raising the crown to get the inner fluke up to the bill-board after catting.

A Fore-and-aft Tackle is one used to get the awnings on a fore-and-aft stretch. The term is also of general application to any tackle whose use, for the time being, may be in the direction of the length of the ship. In the same way we have *thwartship-tackles*.

The Griolet Purchase, Fig. 263, Plate 34, for dismounting guns on covered decks, is composed of-

A *toggle block*, made of elm or oak, the outer end or *head* of which is made rather greater in diameter than the inner one, which exactly fits the bore of the gun. The *head* has two sheaves in it, so as to form the lower block of the *muzzle purchase*, and is bound at the outer end with an iron band.

A double *casable block* of iron is made usually with a shackle, to fit between the jaws of the casable, where it is secured by the casable pin. The iron pins on which the sheaves revolve are formed with eyes, for the convenience of hitching the standing part of the purchase.

Two *iron treble blocks*, one for the upper muzzle and the other for the breech purchase.

The *muzzle purchase block* is so fitted as to be either shackled or toggled to the housing bolt above the port, and the *breech purchase block* has an iron strap terminating above, with an eye by which it is shackled to a bolt passing through the deck above the gun. This bolt has an eye in one end and a screw or key-slit at the other, and when in place, is secured above the deck with a nut or key, between which and the deck a washer of hard wood or iron, of suitable breadth and thickness, is placed.

The hole through which this bolt is put, should be directly above the casable block when the muzzle of the gun is under the housing bolt, and may be bored at the time the gun is to be dismounted; and bouched with a composition screw-tap.

The purchase falls should not be less than three and a half inches in size, and should be made of manilla rope of sufficient length to reeve full, the gun being supposed to be on deck and the upper blocks in place, allowing also sufficient end for splicing in the thimble and hitching the standing part of the purchase when rove.

An iron thimble large enough to hook the double block of a side, or train tackle, is spliced in to the end of each purchase fall.

Garnet Tackle is the purchase used in getting guns in on a covered deck. The garnet itself is a single piece of rope or a pendant passed through a hole, bored for the purpose in the spar deck, and has a hook and thimble

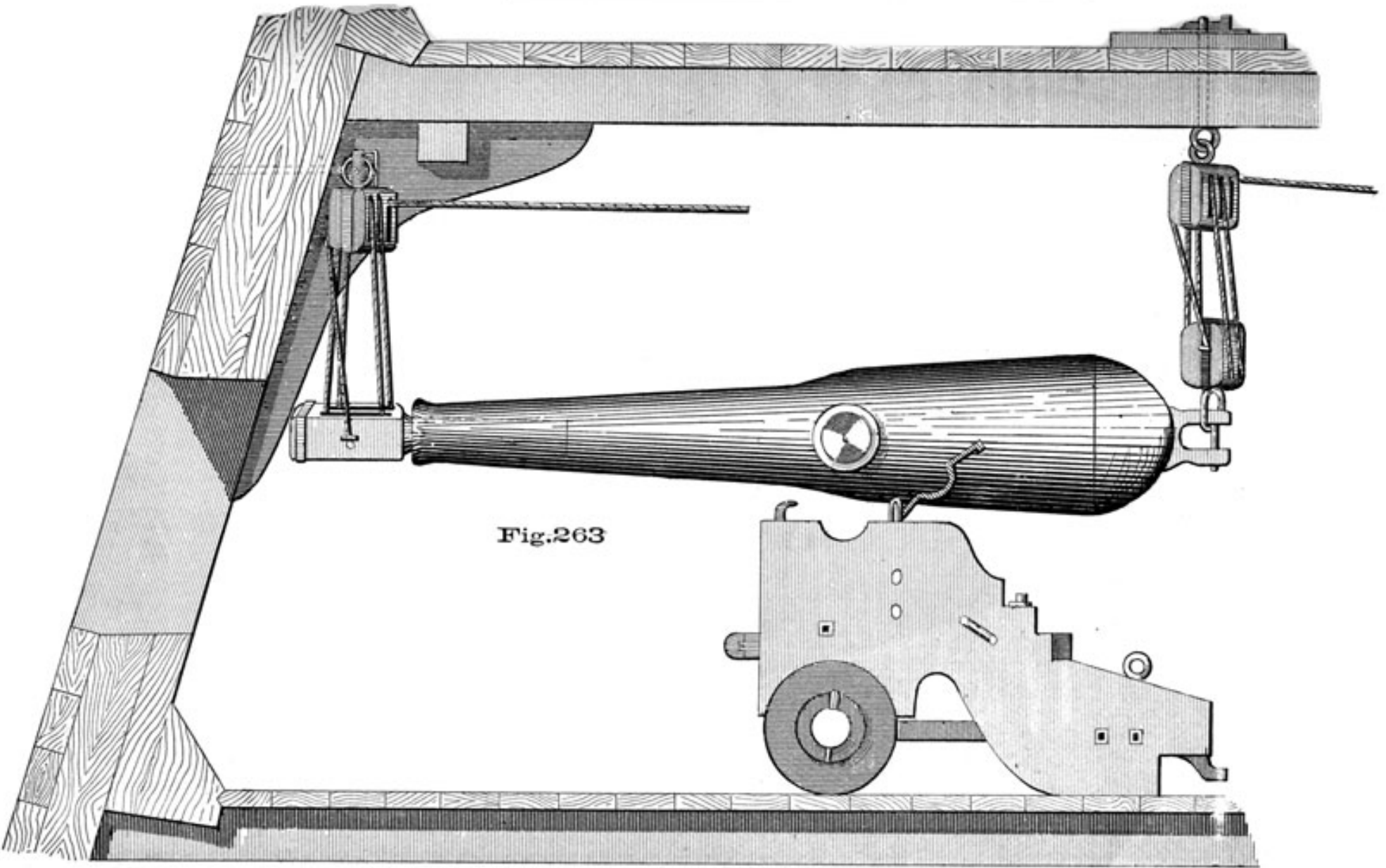


Fig. 264



Fig. 265

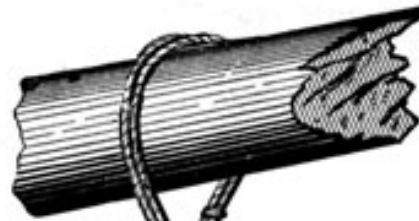
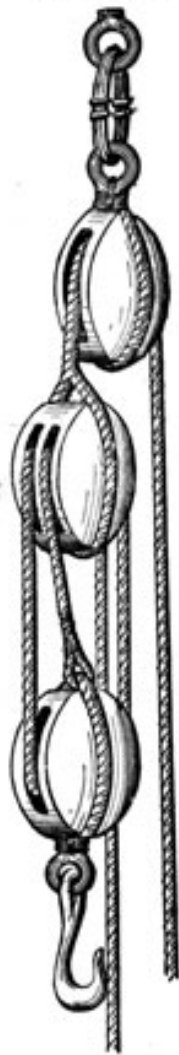


Fig. 266



Fig. 267



Fig. 268





spliced in one end, and a thimble in the other, or upper en 1, to which the pendant tackle hooks.

Girtlines are, generally, single whips. The name applies particularly to those used at the mast-head in getting up tops, rigging, &c., when rigging ship. Hammock Girtlines are simply lines on which to stop scrubbed hammocks for drying. They are fitted in various ways, and formerly had permanent (nettle) stops attached; but now the "long" or harbor clothes-lines are used for the purpose.

Gun Tackle. A double and a single block, or two double blocks. Gun-tackle falls are made of manilla, or such other pliable rope as may be directed from time to time by the Bureau of Ordnance. It is prohibited to blacken them or to diminish their pliability. Three-inch rope will be found large enough for the heaviest, and from 2 1/4 to 2 1/2-inch for the lighter guns.

The rope being well stretched, the falls are cut of sufficient length to allow the full recoil, leaving end enough to hitch round the straps of their double blocks, when hooked to the middle or fighting bolts.

Gun Tackle Purchase. See *ante*. Two single blocks.

Hatch Tackles. These are common luff purchases, and are used generally in the hatches over the holds. When the upper block is required to be above the spar deck, it should not be permitted to hook to the lower stay, but to a long pendant, hooking to the lower cap and stopped out to the stay by a lizard.

Jeers, for sending up and down the lower yards, are variously rove. The plan now is, to have one or two double or treble purchases according to the size of the yard. For small vessels the blocks (iron) are fitted in one with the slings, Fig. 262, Plate 33.

Jiggers, Fig. 264, Plate 35, are small luffs, having the double block strapped with one or two tails, and are used for a great variety of purposes about decks.

Luff Tackle. Double and single block, as already described. But *rigging luffs* used in setting up rigging are either double or single. Double rigging luffs may be ordinary luff tackles or double purchases, used for setting up lower stays, and called *stay luffs*. Single rigging luffs have two single blocks, and are used in setting up shrouds.

We then have-

NAME OF TACKLE	KIND OF BLOCKS.
Luff tackle	One double, one single.
Rigging luff	Two single.
Stay luff	One double, one single, <i>or</i> , two double.
Gun tackle (<i>i.e.</i> a tackle for a gun)	One double, one single, <i>or</i> , two double.
Gun tackle purchase	Two single.

In former days when ships' batteries were light, the gun tackles had only two single blocks, hence the term, gun-tackle purchase; a heavier purchase is required with modern ordnance.

Rigging luffs in former days were composed of double and single blocks, but in time were made up with two single blocks instead, as the double block was too large, much in the way, and liable to split in setting up shrouds.

Retaining the old names, and changing the tackles themselves, has caused a confusion of terms which the above table is intended to simplify.

Pendant Tackles are large tackles, composed of double blocks. They hook to the mast-head pendants, whence their name, and are used for setting up lower rigging, staying the mast, or steadying it under certain emergencies.

Propeller Purchase. A purchase used in tricing up the propeller. See Fig. 277, Plate 40.

Reef Tackles are for rousing the leeches of the top-sails and courses up to the yard arms for reefing. They are variously fitted, and may be either a luff or a gun-tackle purchase, as will be explained hereafter.

Relieving Tackles are for the purpose of hooking to the tiller, in order to steer the ship in the event of the wheel ropes being shot away in action, or to assist in steering in very heavy weather, when the motions of the rudder are sudden and violent. Double and single block.

Rolling Tackles hook to the quarters of the yards (lower and top-sail) and to the mast, for the purpose of steadying the yards in a heavy sea, when the ship rolls much, and to relieve the strain on the trusses, slings, or parrel.

Rudder Tackles hook to the rudder chains or pendants, to steer the ship in case of accident to the tiller or rudder head.

Runners have already been described.

A Runner and Tackle, Fig. 265, Plate 35, is simply composed of a tackle (double and single block) attached to a runner. They are for aiding in staying the lower masts. The power gained is eight times.

Stay Tackles are those which hook to the triatic stay, or a lower stay, and are called respectively, *forestay tackle and mainstay tackle*-used in getting the boats in and out. These are large double or treble purchases

with a hook and several links of chain on the lower blocks. One link is round, and into it hooks the yard tackle.

Side Tackle for running out and training broadside guns. A double and a single or two double blocks.

A Sail Tackle, Fig. 266, Plate 35. The upper block is often double; the small single block below is to act as a fair leader, and the fall to act as a guy in keeping the

sail clear of the yards and top when swaying aloft. The burtons are used as sail tackles.

Stock and Bill Tackle is a small tackle used when securing the anchor.

Train Tackle is composed of a double and a single or two double blocks for running in a broadside gun, or to prevent it from running out in a sea-way, while loading.

Tricing Lines are generally single whips. Sometimes, however, they are gun-tackle purchases, as the fore-topmast studding sail boom tricing lines.

Watch Tackle. A common luff purchase or jigger.

A Whip and Runner. Similar to a runner and tackle, but smaller. The main bowline of a large ship is a whip and runner.

Yard Tackles are large tackles used on the lower yards, in connection with the stay tackles, for getting the boom-boats in and out, purchasing anchors, &c. They are called *fore* and *main yard tackles*, respectively, and are fitted with large double or treble blocks, strapped with single hooks. Fig. 230 shows an inside iron-strapped treble block for yard tackle.

Water Whips are tackles for hoisting in water, when it is brought off in gang casks; or for medium weights generally.

Besides the yard and stay *tackles* described above, for hoisting in and out boats, lighter purchases, known as the *yard and stay water whips*, are used for getting in provisions, Fig. 267.

This purchase consists of two water-whips. The upper block of the stay whip has a pendant which hooks into the lower cap, and is fitted with a lizard hauling it out to the collar of the lower stay, where it is secured.

The upper block of the yard whip is fitted with a strap as in Fig. 267 to go around the yard arm. Both lower blocks may be fitted with chain pendants and hooks. Sometimes the lower stay block alone is fitted with chain, the lower yard block having a hook only.

Besides the foregoing, there are various jiggers and whips, all of which will be explained when used.

General Remarks. One great advantage of a tackle on board ship, which renders its application of constant occurrence when mere power is not wanting, must not be overlooked; as, for example, when hoisting, a jerking is to be avoided, and a steady, gradual strain required, as in staying a mast. Another advantage of a purchase, when fitted to any part of a ship's rigging, is that on *coming up*, when some little must necessarily be given back, only a mere fractional part is lost on the rope itself, as in the laniard of a dead-eye, &c.

The greater the amount of purchase used, the steadier will be the strain.

The *swallow* of a block should be full large in proportion to the size of the fall; generally one-tenth of an inch swallow for every one-fourth of an inch in circumference of the rope.

The fall of a purchase should have as clear a lead as possible, and the hauling part be in a line parallel to the rest of the purchase.

A score is generally cut in the breech of a block to admit the standing part of the fall being passed under the strap, so as to splice the end into its own part. When this is done, the splice should be tapered and neatly served over with marline. But in jiggers, luffs, deck and pendant tackles, the standing part is bent to a becket, worked around the strap of the single block, with a sheet or becket bend, and the end stopped down. This is to allow the fall to be shifted, end for end, or to be unrove at pleasure.

By reason of friction, the becket in the breech of the standing block may be much less in size than the fall, as the fall there bears less strain than at the hauling part, and the greater the number of parts of a fall, the greater will this difference be. Notwithstanding this, in heavy purchases, where great weights are to be

moved, the standing part is hitched around the neck of the strap, between the block and the thimble; and it is a good precaution, when using any tackle for a great strain, to cast off the standing part from the becket and hitch it around the strap. In large blocks, the standing part is made to go on the side *opposite* to that from which the fall *leads*, making it lead fairer, and preventing the tendency of the block to slew in the strap. Fig. 268, Plate 35.

When a *racking* is to be put on a purchase fall, the hauling part is racked to the part next to it.

Sometimes, as in the case of a boat's fall, by the block capsizing, or through carelessness in overhauling, the fall gets a *thoroughfoot* in it—that is, the parts get crossed; before use the thoroughfoot must be taken out.

The following is the result of a carefully-executed experiment with tackles:

A tackle of 2 upper and 1 lower sheave requires on the fall $\frac{3}{5}$ of the weight of the resistance in order to raise it, but only $\frac{1}{4}$ to sustain it in its place. In hoisting, the standing part takes a strain of about $\frac{1}{3}$ of the weight suspended, $\frac{1}{4}$ in keeping it suspended, and $\frac{2}{5}$ in lowering the weight. When composed of one upper and one lower sheave, the fall of the tackle requires the exertion of a power equal to about $\frac{5}{9}$ of the weight to move it, and $\frac{4}{9}$ to keep it in equilibrium, so that the strap should be 3 times the strength of the fall, or $1\frac{1}{2}$ times its size.

The Purchase gained by Swigging Off.

What is called swigging off—that is, pulling at right angles to a rope, is, at first, a very great power; but it decreases as the rope is pulled out of the straight line. A purchase upon this principle may be conveniently applied to several purposes. By it a boat may be hauled up on the beach. At some distance up from the water, drive in a stake, and near the water, in a line with the boat, drive in another. To the upper stake secure the boat's painter, passing it along against the lower one. Now, by swigging off upon the painter midway between the stakes, the boat's crew will pull with an increased power, and if this be insufficient, it may be increased by moving the stakes farther apart.



[Seamanship](#)
[Home Page](#)



[Next Part](#)

Copyright (C) 2006 [Historic Naval Ships Association](#)

All Rights Reserved

[Legal Notices and Privacy Policy](#)

Version 1.00, 24 Apr 06

MASTS AND YARDS.-RUDDER.-MASTING.

Wooden Lower-masts are made of several pieces, united by dowels or coaks, and hoops.

In the United States Navy, the made masts consist of four principal pieces, each of which consists of two or more parts, scarfed together, when a whole piece, of sufficient length, cannot be obtained. These pieces are placed as in Plate 36 P. The inner corner of each piece is taken off so as to leave a square hole extending throughout the whole length of the mast, in its axis. This admits of a closer contact of the parts of the mast with each other when the hoops are set up, and does not take from the strength of the spar. This hole is one-tenth of the diameter of the mast in size.

The hoops are placed from three to three and a half feet apart from each other, and are from four and one-quarter to five inches wide, and from four-eighths to five-eighths of an inch thick, according to the class of ships the mast is made for. They must, however, be kept clear of the wedges at the partners. The scarfings of the piece must be kept clear of each other (that is, the points of junction in one piece must be as far as possible from those in another piece), and equally distributed in the mast. There is a *chafing batten* on the forward part of the mast, about one-fourth the diameter of the mast in width, and one-eighth in thickness.

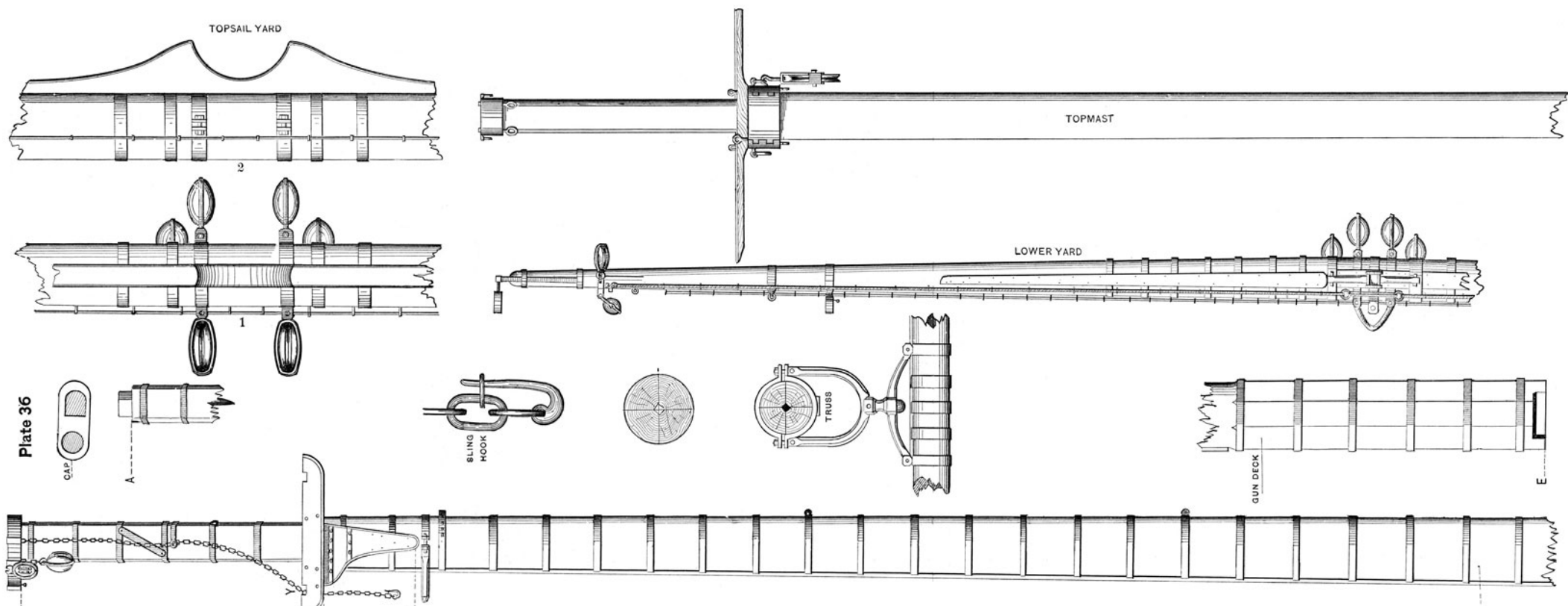
The principal parts of a mast are the *head, hounds, bibbs, neck, partners* and *heel*.

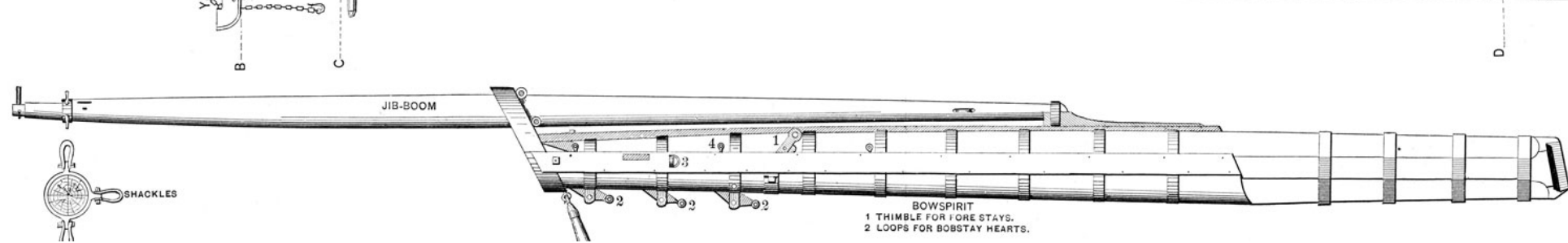
The head, A B, Plate 36, extends from the upper extremity of the mast to the top of the hounds, and is one-sixth of the whole length of the mast, nearly.

The hounds are the shoulders produced by enlarging the diameter of the mast a few inches at the lower limit of the head.

To the sides of the hounds of the lower masts are bolted, and otherwise secured, fitted pieces of oak, of the shape shown in Plate 36, and called *bibbs* (B c). These, with the hounds, form the foundation for the tressle-trees. The small part of the mast, just below the bibbs, is called the *neck*.

Where the mast is wedged, at D, is called the *partners*; but a more correct definition of the term is given on page 7.





81

The lower part of the mast, E, is called the heel, and the upper projection, A, the tenon.

The *doublings* of masts are where the head of one mast doubles on the heel of the other.

The yards, booms, and masts are usually made of yellow pine and spruce. The latter is selected for small spars.

Masts are most liable to decay at the heel, partners, and cap.

Masts are most liable to spring at the partners, tail of bibbs and hounds; bowsprits at the cap and on top between the gammoning and cap.

Tops are constructed of two thicknesses of white or yellow pine, with the *rim*, lubber-band and battens of white oak. The upper cross-trees are fayed down over the battens, and secured to the lower cross-trees by bolts at each end, and by four staples and toggles, so as to be readily removed when it is necessary to lift the top.

The Bowsprit is represented in full length in Plate 36. At the side the *bees* are shown extending from the cap to the *housing*, or where the octagonal form commences.

The parts marked 2 are of iron, and to them shackle the hearts for the inner, middle, and cap bob-stays.

The bowsprit cap is iron-bound. To an eye-bolt on the lower side is hooked the dolphin-striker.

Above the strap for the middle bobstay is an eye-bolt, to which hooks the whisker, 3.

Next outside is a sheave for the fore-topmast stay. An iron strap marked 1, containing a heavy, solid thimble, is for the fore-stay. There is one on each side.

Eye-bolts are represented on top of the bees, for bowline blocks, 4.

The eyes to which shackle hearts for bowsprit shrouds are not represented.

The Jib-Boom is represented in its place. The heel is cut to fit in a saddle bolted on the top of the bowsprit, and is clamped down by an iron strap; a short distance outboard is a sheave for a *heel-rope*.

Just inside the hounds is a sheave-hole for the jib-stay. Over the hounds fits an iron band having three shackles; one for the jib martingale stay, and one each side for the jib-guys. Immediately outside this band is a score for the foretop-gallant stay.

Lastly comes the *wythe*, a species of iron cap to support the flying jib-boom.

The Lower Mast has the cap on. To an eye in each end of a strap passing over the cap, shackle the chain slings for the lower yard. A back-strap about halfway down the mast-head, gives it a better lead.

The double block, hooked to an eye-bolt in the cap, is for the lower lift. The single block is the *top-block* for sending

6

up the topmast. The chafing-batten is shown on the forward side.

The tressle-trees are in place. Just below the bibbs comes the band for the patent truss, and below it the futtock-band to which shackle the futtock-shrouds.

The Topmast has the cross-trees and cap on.

The forward part of the tressle-trees has a clamp. By opening this the sending up and down of the top-gallant masts is greatly facilitated. The eye-bolts under the tressle-trees are for the hanging-blocks for the head halliards.

One gin-block, for topsail-tye, is represented in its place. It should be hooked to the eye of a strap fitting *over* the tressle-trees and between the doublings.

In the forward part of topmast cap, are eye-bolts for the top-gallant top-block, and standing part of top-gallant mast-rope. Fitting over the topmast cap is an iron strap with a link in each end for block of topmast studding-sail halliards.

The Lower Yard has in the centre a stout iron span, to which hook the slings.

The two lower blocks are for the topsail-sheets. The two partly concealed are for the clew-garnets and hook on the forward quarter.

On the after side of the yard is nailed a chafing-batten.

Next outside is the quarter-iron for topmast studding-sail boom.

Next comes an iron burton-strap.

Outside of it is shown the eye-bolt for head-earring of the course.

On the yard-arm are the brace and lift blocks, shackled to an iron band.

Outside of all is the "pacific iron" on which fits the boom-iron.

The bending-jackstay (iron) is seen on the top of the yard.

The truss is shown in a separate figure.

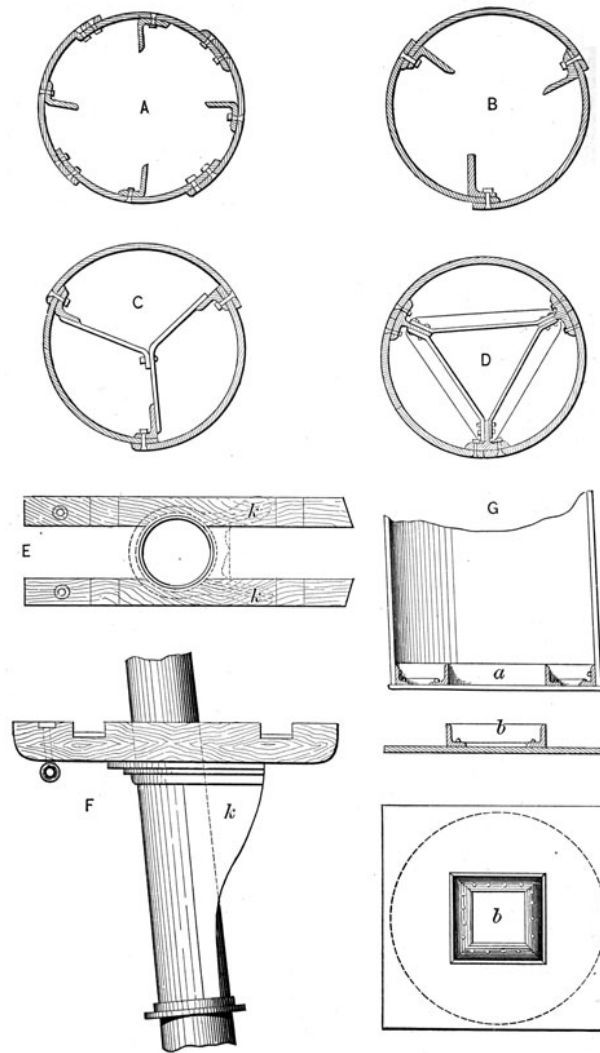
The transverse section of the mast P shows the method of joining the principal pieces of which a mast is made.

The Topsail Yard, in two views, shows the jaws, tye-blocks, bending-jackstay, quarter-blocks for topgallant sheets and additional blocks, forward, for top-sail clew-lines.

Over the topmast head is frequently fitted a rectangular funnel of metal with a projecting flange at the base to receive a quarter-round piece of wood, or bolster, upon which the eyes of the rigging rest.

Round funnels are also fitted for the top-gallant and royal mast-heads, and on them are fitted the eyes of the top-gallant and royal rigging.

Yard-Slings, Y, Plate 36, are of chain, in length twice that of their respective mast-heads; to which must be



added half the length of the forward lower cross-tree, that being the distance the yard should hang below the top. The upper section, *i.e.*, above the top, should be shackled together, keckled with a piece of large stuff to make it round, and neatly covered with canvas. The size of the chain necessarily depends on the weight it is required to support.

They hook to the yard by the sling-hook, as represented in the plate.

Preventer Slings for topsail yards, used when preparing for action, are made of chain and go around the mast-head.

Iron Masts. In the equipment of ships one of the modern applications of iron has been its use in constructing lower masts.

An iron lower mast is made up of plates, each bent to form an arc of a circle, usually 120 degrees, and connected at the edges and ends by through-riveted lap-joints or covering strips, the structure being usually stiffened by continuous interior **T**, or angle-irons.

Iron masts are commonly made of the same diameter as the wooden masts they have replaced, and for

large ships are generally lighter than wooden masts of the same dimensions. The iron lower masts used in the British navy are more expensive than wooden masts of the same dimensions, and are of nearly equal weight, but the advantages gained in strength and durability are such as to outweigh the consideration of expense.

Fig. A, Plate 37, shows the section of an iron lower mast, in which there are four plates in the circumference, connected by double-riveted lap-joints, and stiffened by four continuous angle-irons worked upon the centre of each plate.

Fig. B, Plate 37, shows the angle-iron stiffeners placed so that the edge riveting shall work in as fastenings in the stiffeners.

In order to stiffen masts still further, the flanges of the stiffening bars are often connected by braces or horizontal stays. These stays afford a means of climbing up inside the mast for the purpose of inspecting, cleaning and painting it. The stays are placed at intervals of from 4 to 6 feet. Fig. C, Plate 37, shows the earlier, and Fig. D the latest practice in the British service in strengthening the iron lower masts.

Figs. E and F, Plate 37, show the mode of fitting wooden trestle-trees to an iron mast. As there are no shoulders at the hounds, special provision has to be made for supporting the trestle-trees, and this is accomplished by working a plate and a ring of angle-iron around the mast, and fitting plate-knees, *k k*, which correspond with the bibbs usually fitted below the trestle-trees of a wooden mast. The plan E

shows the spread of the knees and the arrangement of the plate and angle-iron below the trestle-tree.

It is usual to work doubling plates upon the lower masts in the wake of the wedging decks. These plates give additional rigidity in wake of the wedges, and also prevent corrosion in the mast-plate itself.

Fig. G, Plate 37, shows the ordinary mode of forming the heel of an iron lower mast. The end of the mast is dosed by a circular plate fitted against and connected with the outside plating. In the centre of this plate there is a square hole, around which the angle-iron frame *a* is fitted, the vertical flange of the angle-iron thus forming the sides of a mortice in the heel. When in place, the mast rests on a stepping plate, upon which is riveted a rectangular box-shaped frame of iron *b*, and the tenon thus formed fits into the mortice in the heel of the mast.

A man-hole is usually cut a few feet from the lower end of an iron mast to give access to the interior and for ventilation; other openings are also made at various heights for the latter purpose.

Iron and steel have also been used in the construction of topmasts, topgallant masts and yards, but in these spars the advantages resulting from the change from wood are not so great as in the case of lower masts. The details of construction for the lighter spars do not differ greatly in principle from those described for lower masts. The plating is usually flush-jointed, and the larger spars have angle-iron, or other interior stiffeners.

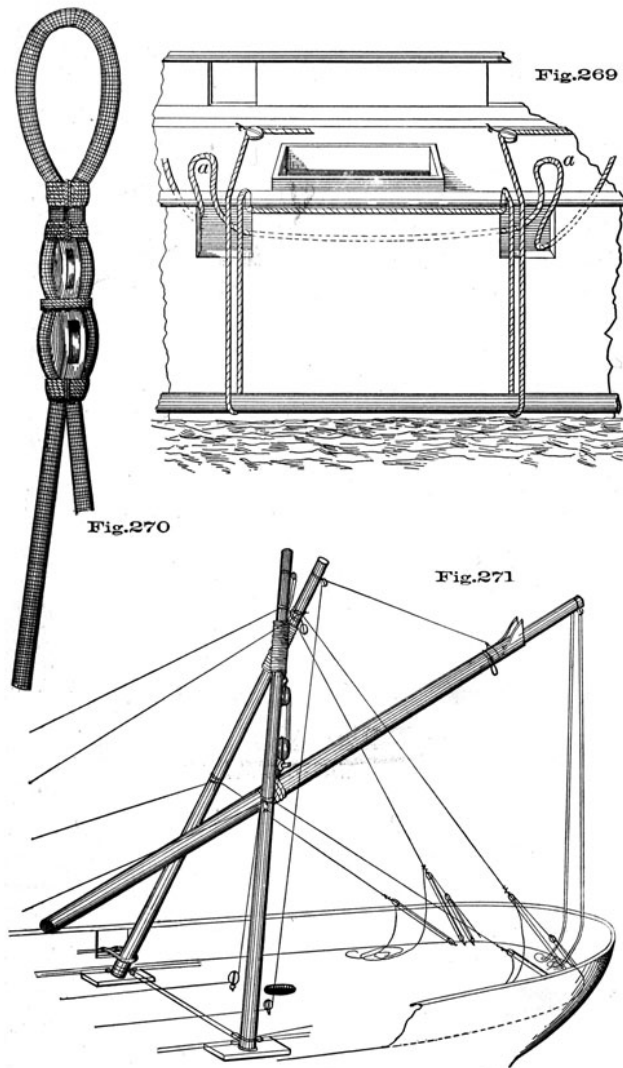
Masting. In fitting out our men-of-war, advantage is taken of every facility which a navy-yard affords. The rigging is cut out by the draft furnished by the constructors, using the Equipment Book of Allowances as a guide. The masts are placed by the navy-yard sheers, and the hold stowed by regular stevedores.

When the navy-yard sheers are used, the mast is brought down from the spar-shed and placed with its head toward the ship under the sheers, or masting-derrick, the garland lashed on and the main purchase toggled, the fall being taken to the capstan, or *crab*, built for the purpose. Convenience determines which mast is to be taken in first. After placing one mast, the ship is hauled ahead, or dropped astern, to bring the other partners plumb under the purchase.

In the following outline of masting, the work is assumed to be done without the conveniences of a yard. The vessel, a frigate, is supposed to be lying in the stream, and her spars, &c., towed off.

Proceed to support the spar-deck for the weight it will have to sustain, by *shoring* it up fore and aft,* particularly

* *Shores* are stout pieces of timber or joist, placed under a beam and resting on a block. To give the deck above a proper support, they must be wedged up.



those beams immediately under the places to be occupied by the sheers when getting in the masts.

Sling skids outside leading from the gunwale to the channels, and from the channels to the water's edge; block up a half-rounded spar in the hammock netting, the upper surface being well slushed, to lead the parbuckle over, and proceed.

To Reeve the Parbuckle, Fig. 269, Plate 38. The main parbuckle consists of a hawser of a suitable size—say 5-inch—which is middled and the ends rove through the spar deck ports, a few ports apart (the distance depending on the length of the sheer legs), from *out, in*, leaving the bight outside. The sheer legs having been towed alongside, with their heads aft, pass the after end of the parbuckle down under the head of the first sheer leg, up over the gunwale to the opposite water-ways, where the end is snatched and led forward, having a long luff clapped on it, if found necessary. The forward end of the parbuckle is led in like manner, taking it under the heel of the sheer leg, and thence to the capstan.

The Counter Parbuckles, *a a*, Fig. 269, are rove in a contrary way, for easing the sheer legs inboard. They are rove through the same ports, from *in, out*, leaving the centre bight inboard, and the two end bights hanging down inside to catch the sheer leg when it comes over the gunwale; the ends are led down

through the gun deck ports and taken around spars lashed fore and aft in the ports, having hands to attend them to ease the sheer legs down. Have a stout spar laid across the gunwale well aft to rest the heads of the sheer legs on when on board.

When ready, clap on the luff, man the bars, and "*walk away*." When "high enough," or up with the gunwale, "*avast heaving*," arrange the counter parbuckles under head and heel, and set taut. Now pull up on the main, and ease away on the counter parbuckle, land the heel on the deck, the head resting on the thwartship spar placed for the purpose, roll it over, lift the heel over the capstan and get it in its proper position for forming the sheers; a spar may be placed from the gunwale to the capstan, and the sheer leg got thence to the opposite water-ways. The second sheer leg is got on board in the same manner, and placed for lashing.

NOTE. Instead of using parbuckles, the sheer legs may be got on board by means of a pair of small sheers, raked over the taffrail.

Fore and main topmasts or *lower yards* may be used for sheer legs; in the latter case, the yard-arms must be well strengthened, or *fished* and *wooldeed*, by lashing around them small spars, or *made fishes* of stout oak plank, using well-stretched rope, and tautening the lashes by wedges. The lashing around the spar is termed a *woolding*.

86

The Sheers. The sheer legs being on board, cross their heads (with the port leg uppermost if the masts are taken in on the *starboard* side), square the heels and spread them about two-thirds the breadth of beam at the mizzen partners, so that when spread out to their full extent, the sheer head lashings may be tautened.

For sheer head lashings, take a piece of good 3 1/2 or 4-inch rope, well stretched, middle it and make one end fast to the sheer leg, near the cross; with the other end pass the requisite number of figure-of-eight turns round both spars and take a couple of half-hitches with the end around one leg. With the first end, pass a number of round turns, filling up the intervals between the figure-of-eight turns, pass frapping, or cross turns, and secure the two ends with a square knot.

After passing the sheer head lashing, spread the heels and place them in the shoes. The shoes should be of stout oak plank, long enough to rest upon at least two of the spar deck beams. A saucer is cut out of the centre to rest the heel in, and on the forward and after side an eye-bolt is placed for lashing the heel to. There are eye-bolts in the forward and after ends, for hooking fore and aft *shoe-tackles* to, to aid in the transportation of the sheers. Lash the heel to the shoe temporarily. Hook the after heel tackles to straps around the heels and set them taut, and, as an additional security, when raising the sheers, shift the forward heel tackles aft.

The Main Purchase. Lash on the upper block of the main purchase, so that it will hang directly under the cross. It should be a large threefold block, strapped with two single straps and fitted with a large thimble, to hang by a lashing passing over the cross of the shear head.

The straps of the main purchase blocks should be well parcelled and marled. The lower block is double-strapped, with eyes for toggling, Fig. 235, Plate 31. Take the lower block of the main purchase to the bowsprit hole, and toggle it there with a suitable spar.

The fall should be new 5 1/4-in. Manilla rope. Begin with the standing part and reeve it from *forward, aft*, through the side sheave of the upper block, beginning on the side opposite to that intended for taking in the masts; thence through the corresponding sheave in the lower block, and so on until rove full, when clove hitch it around one of the forks close to the lashing, and stop the end down to its own part. Snatch the fall in some convenient place near where the lower block has been toggled, and take it to the capstan.

If apprehensive that the upper purchase block will slue in its strap, by the greatest strain coming on one side, the fall may be rove so as to lead from the centre sheave-

but this brings a cross in the fall, and is, therefore, objectionable.

The Small Purchase, Guys, &c. The upper block of the small purchase is double, and lashes to the after fork so as to play clear of the main purchase. Lash a single block to each fork above the small purchase and reeve stout girtlines. For sheer-head guys, clove-hitch a couple of stout hawsers over the sheer head, leading two ends forward and two aft, and to each clap on a luff-upon-luff for convenience in setting up and easing off, without surging. Belly guys are put on in the same way, about one-third the distance down each leg, cleating the hitches to prevent slipping, and clapping on luffs. On each sheer leg just above the shoe, put good straps, and hook and set well taut a thwartship tackle to ease the strain on the water-ways; lastly, pass a bulwark lashing either to the bulwark, or to a stout toggle placed outside of the spar-deck ports.

Raising the Sheers. The main purchase fall, being led to the capstan, the heels temporarily lashed to the shoes, and the forward and after shoe and heel tackles, both hooked aft, to prevent the sheers from launching forward as the strain is brought on the main purchase; the thwart-ship heel tackle set well taut, and plenty of hands to take in the slack of forward guys, and others to attend after ones, man the capstan, and heave around, catching the sheers as they rise, by the thwartship spar.

When nearly up and down, or at an angle of about eighty degrees with the spar deck, "avast heaving," lash the heels in the shoes securely, shift the forward heel and shoe tackles, cast off the bulwark lashings, and transport the sheers to just *forward* of the mizzen partners (having previously wet the deck), by moving one leg at a time. The sheers should have a slight rake aft, and the main purchase hang plumb with the mast-hole. The fall may lead through a block toggled through the ward-room sky-light and thence to the capstan. When the sheers are in position, set up the after head and belly guys, leading to the quarters; and the forward ones, leading well forward; set taut the thwartship tackle, and pass the bulwark lashings, or substitute for it a good tackle—the main object of which is to prevent the opposite heel from rising when raising the mast from the water. Now overhaul down outside the main purchase and toggle to the garland on the mizzen-mast. Fig. 271, Plate 38.

The Derrick. It may occur that the angle of the sheers with the deck, before raising, is so small that the main purchase will not be effective, in which case it will be necessary to start them up with a derrick, as follows:

A small stout spar (say a stump top-gallant mast) is

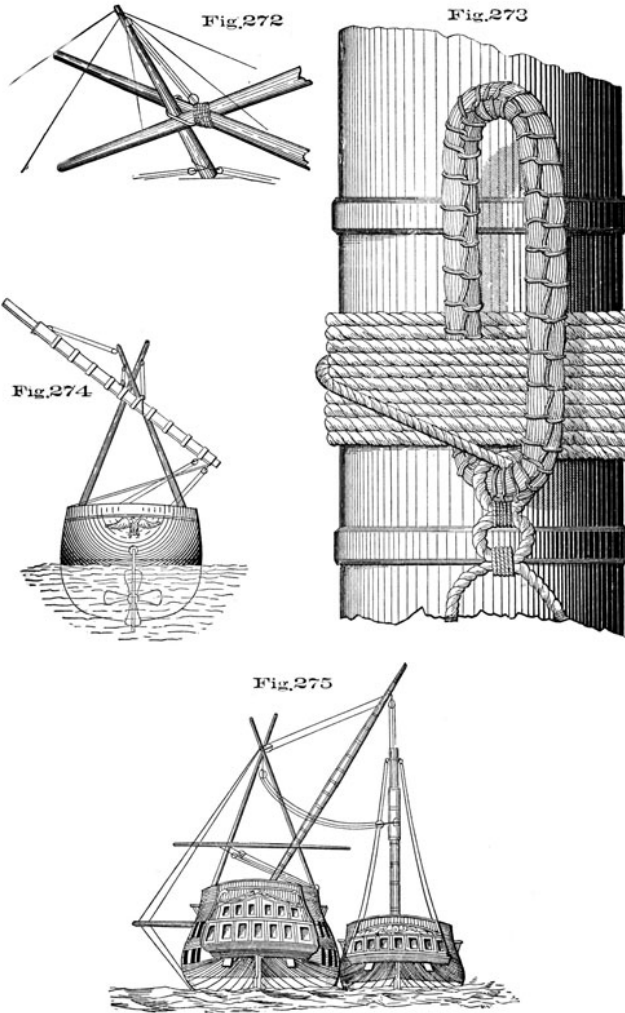
placed between the cross of the sheer-forks, where it is retained by a loose lashing. Hook a stout tackle from the head of this spar to the sheers, and attach two other (canting and heel) jiggers together with head-guys, as in Fig. 272, Plate 39. With these, get it erect, slushing the spar and the forks at their points of contact. Now, with the assistance of the tackle, the head of the sheers can be elevated to a considerable degree, and the main purchase made to act, at an angle sufficiently great, to raise the sheers without further difficulty.

Getting in the Lower Masts. The mizzen mast is taken in first, because the breadth of beam is less aft, and the sheers, as they are transported forward spread the heels and tauten the sheer head lashings; and for the reason, that getting in the foremast last, the sheers may be better secured and raked for getting in the bowsprit.

The Garland. Fig. 273, if used, should be of good four-inch rope, made selvagee fashion, marling it with small stuff. It is lashed on the forward side of the mast about six-tenths from the tenon, so that the mast will hang a little heel heavy. The distance from the heel must in any event be such that the garland may not take in the partners before the heel is landed. The garland lashing is passed as in Fig. 273. After passing enough turns, dog the ends down the forward part of the mast and seize them together. The garland should be lashed on before the mast is put in the water, not only for the greater convenience, but the subsequent wetting tautens the lashings very considerably. If the small purchase is used-as in getting in the main and foremasts, its garland is placed on the mast as far above the main garland, as the small purchase block is lashed on above the main. If practicable, the lower purchase blocks are lashed to the mast and the garlands dispensed with.

To take in the Mizzen-Mast. Fig. 271. Tow the mizzen-mast alongside with the head aft. Having overhauled down the main purchase abaft, shove the two eyes of the lower block strap through the garland and toggle it, using a small lashing to guard against slipping.

Man the capstan and "heave around," observing that the skids and mats, or whatever has been placed to protect the ship's side from chafing, are properly adjusted. When the mast-head is up with the gunwale, "avast heaving," lash a couple of stout single blocks to the tenon, one on each side, and reeve girtlines, taking the precaution to knot the ends together to prevent unreeving. Put a couple of good straps around the mast, just above the futtock band, for pendant tackles, and bend the canting girtline, from the sheer-head to the mast, just below the bibbs; sway up again until high enough; ease the heel inboard by a jigger, coming up the belly guy, which must be set up again. Pull up on the canting line and point the mast fair for stepping.



wipe the heel dry, and white-lead the tenon and mortise, have hands on the gun-deck to keep the mast on the right slue, and carpenters on the berth-deck to attend at the step, lower away and step the mast. Sway up three pendant tackles and hook them to the straps about the masthead-the two at the side set up in the channels, and one fore-and-aft to act as a stay; set taut the tackles and wedge the mast temporarily. When nearly stepped, a stout strap and heaver may be used to get the mast on the right slue.

Come up the purchases and take off the garlands. Cast off the bulwark lashing, man the guys, shoe and heel tackles, and transport the sheers, one leg at a time, observing to wet the decks and come up the thwartship tackle in the wake of obstructions; get them a little forward of the main partners, rake and secure them as before.

If the sheers are high enough or can be made available by spanning the fork above the sheer-head lashing, send up the tressle-trees, &c., of each mast, before transporting them to take in the rest.

Take the main and foremast in, in the same manner, with the additional use of the small purchase.

Should the sheers prove too short, the fork above the lashing may be spanned by a stout rope and the upper block of the small purchase lashed to the span. If the garland *takes* in the partners before the mast is stepped, the heel may be rested on blocks, or stout planks, the mast steadied by the guys and the garland shifted higher. Should the sheer-legs be found too slender and to complain, a spar may be lashed across from one to the other, in the wake of the guys.

When both purchases are employed in getting in heavy masts, a good plan, and one which obviates the necessity of heavers on the heel, is to lash the garlands, a little on each side, and *not* in the same right line with the axis of the mast. Then, by slacking one purchase and holding on the other, it may be slued at pleasure. The position of the small garland should be at the distance of *its purchase block, from that of the large one, on the sheers*, above the main, so that the falls cannot come two blocks except at the same time.

When, in dismasting, a mast is jammed in the step, a gentle roll given to the ship will start it.

To get in the Bowsprit, Fig. 276 A, Plate 40. Transport the sheers as far forward as the bows will permit; send a hand to the sheer head, bend a girtline to the small purchase block and light it up; unlash and shift it to the forward side of the sheer head. Pass a strap around the foremast head, to which hook the double block of a large tackle; the other block take aft and set well taut. Lash a couple of large blocks to the foremast head; middle a hawser

and clove-hitch it around the sheer head, reeve the ends through the blocks at the foremast head, lead them aft and set them up; take aft the forward head-guys, which, with the after ones, are to be set up, and the forward belly guys to the cat-head; hook the after-shoe and heel-tackles forward and set them taut. Rake the sheers over the bows so that the main purchase will clear the billet-head.

The bowsprit is towed under the bows, with the head forward, the cap on, and the main garland lashed on a little over one-third its length out from the heel, or so that it will hang head heavy. The small garland, lash on just inside of the cap. Have guys or whips from eye-bolts in the cap to the cat-heads, and an eye-bolt in the heel for the bedding tackle which leads from the bits on the gun-deck out through the bowsprit partners.

In getting in a bowsprit in modern vessels, the thrust of the heel, owing to the necessary lead of the purchases may be so great as to push the heel inboard too soon, before it is pointed fair for placing. To diminish the thrust and get the spar on the right slue use a fore-and-aft outrigger (stunsail yard) with one end against the neck of the strap on the lower purchase block, and the other controlled by two heel tackles.

Sway away on the main and small purchases, steadying the spar by the guys. When the heel is high enough, hook the bedding tackle. Wipe the tenon dry, and white-lead it and the mortise. Keep fast the small purchase; ease away on the main and bowse on the bedding-tackle and cat-head guys, and get the bowsprit in its place. Come up the purchases and guys, and unlash the garlands.

The bowsprit rests on the stem head, between the knight-heads, and steps in the bowsprit partners-on the gun-deck in a frigate and on the spar-deck in a sloop-of-war. It comes inboard about one-third its length. If the cap was not on, it may be shipped by means of a small pair of sheers, stepped on the bees.

If, by taking the forward head guys well aft, and setting them up, the support is found sufficient, the hawser at the sheer head may be dispensed with.

To Dismantle the Sheers. Proceed now to dismantle the sheers. Take the after heel tackles aft, come up the bulwark lashing, and rouse the heels aft, easing away the forward heel tackles, the head guys and the hawser, and lower away until the sheer heads rest on the knight-heads; strip the sheer legs, cast off the sheer head lashing and get each leg aft in the gangway; unreeve the hawser from the foremast-head and send down the single blocks. Put straps on the ends of the sheer legs and hook the fore and main pendant tackles to them, having the opposite tackles set well taut. Hook to the same straps, jiggers leading in from the channels. Pull up on the

tackles, rose out by the jiggers and lower the sheer leg overboard, taking care to have skids in the proper places to prevent chafe, or the spars taking against the dead-eyes in the channels. Or, the sheer-legs may be got down by lashing their heads separately to the lower mast, casting off the cross lashing and lowering them by means of the pendant tackles.

In masting or dismasting with one's own resources, it is necessary to measure the lengths for slinging the masts very accurately, so as to make sure of carrying the heel clear of the upper deck, and yet avoid, if possible, top-heaviness. When the spars are short for the work (as in the case of the topmasts of a high ship), the masts must be slung so low as to make top-heaviness unavoidable. In going out, when the heel of the mast is near the upper-deck partners, tackles are put on above from each side of the upper-deck, and one strong and long one, led from below through the lower mast holes, is lashed to the heel, and well cleated each way. The tackles are tautened until, the heel being clear of the partners, they are eased away, and the mast lowered head foremost overboard, Fig. 274.

In coming in, the mast is slung above the balancing point and hoisted with an extra tackle alongside the sheers; the purchases are then lashed low enough down, and the heel is confined to the side by the turns of a greased hawser passed through the ports; or, in a merchant ship, through the ballast-hole. When the heel is nearly up to the highest bight, deck-tackles are lashed on from all sides, which are cleated in their place. These are tautened as the mast rises, and guy the heel, when high enough, into the mast-hole.

In handling a bowsprit with your own resources use the jibboom and spare topmast for sheer legs; or, if the fore-topmast is sent on deck, it may be used as one of the legs. The sheer head may be supported by the foretop pendants thus: Each pendant is taken through its top block at the lower mast head, thence through a top block on the upper side of each sheer head in wake of the lashing, and made fast at the foremast-head. The after ends of the pendants have the top tackles clapped on to them, led from as far aft as possible. Take the usual precautions in shoring the decks, etc. Bring the inner purchase as close in to the heel of the bowsprit as the housing permits, and the outer purchase well inside the cap. Use the spar above described to counteract the thrust in coming in. The position of the purchase blocks on the bowsprit is determined by the length of the sheer legs, which in this case would be comparatively short. The bowsprit might have to come up athwartships, when suspended, to clear the billet head. This slueing is effected by the tackle from one of the catheads; the tackle

from the opposite cathead will slue the spar fore and aft again when above the billet head, the heel tackle being previously hooked to assist in placing the bowsprit.

A long topgallant forecastle will make it difficult to handle the bowsprit with improvised sheers alone, as they are too short to get sufficient cant and make the main purchase clear the billet head. In that case the sheers may be assisted by a topmast used as a derrick. Fig. 276 B, Plate 40, shows such a derrick, the sheers being represented as formed of two lower yards, fished.

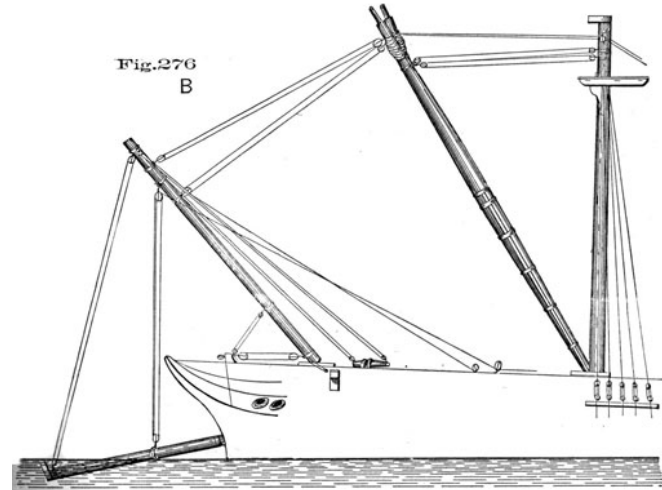
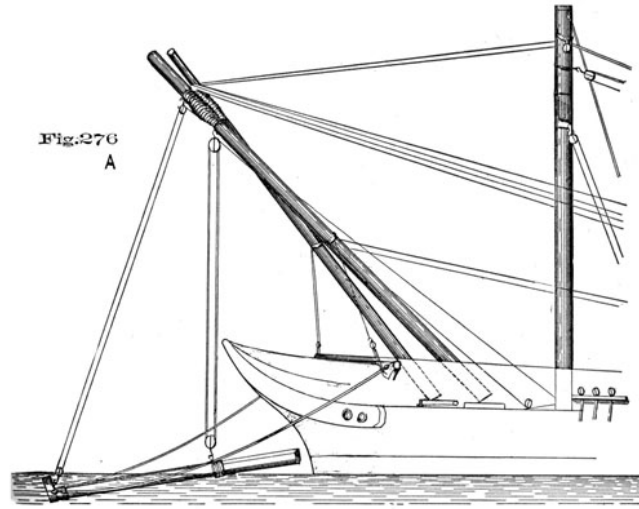
Vessels with long topgallant forecastles such as the "Omaha", and class, are likely to have comparatively light head booms and short bowsprits. In such cases a topmast alone, used as a derrick, might suffice to get in the bowsprit.

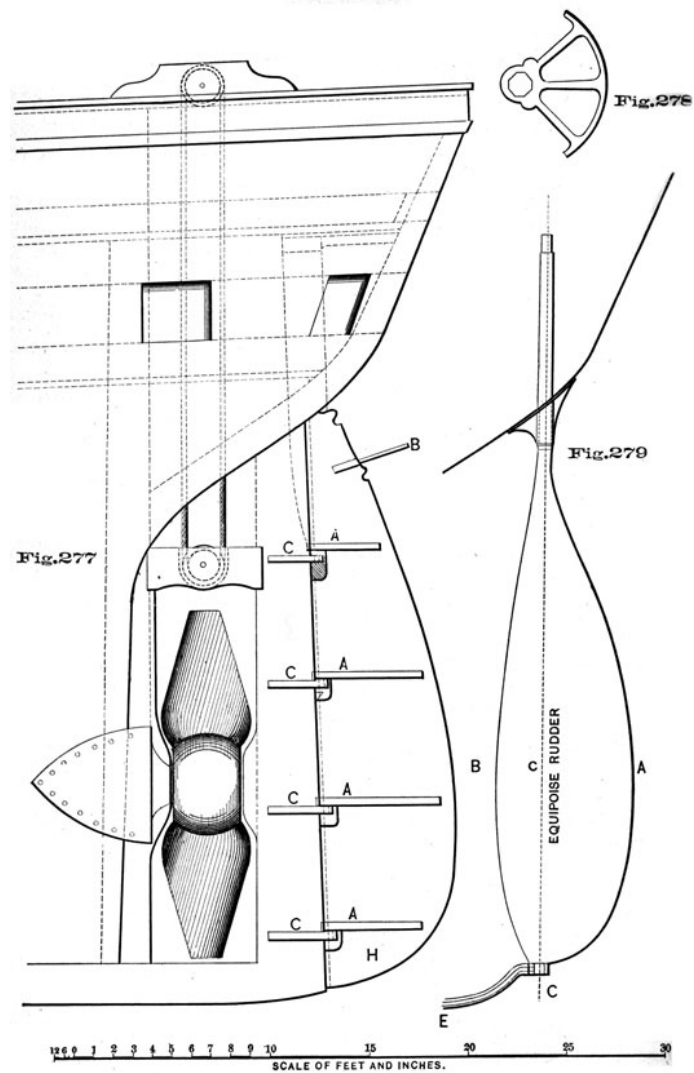
A neat performance in the history of *Masting* on one's own resources was in the case of an English line-of-battle ship, which, having lost her own mainmast, helped herself in one operation to that of a captured frigate. Sheers were formed of the main-topmasts, whose heads were supported by guys set up to the fore-topmasts, which were rigged out through the main deck ports on the off-side. A derrick was made of the main yard, which was secured at its lower quarter to the sheer leg on the working side, the pressure at this point being relieved by an athwart-ship spar, thrusting outward, by means of a tackle led across the deck. The purchase on the upper arm of the derrick took the mast out, the frigate was dropped astern, the mast lowered until the sheer purchase "looked" well up and down, when that tackle brought it in. Fig. 275, Plate 39.

Besides carrying duplicates of some of the important spars, vessels of war are supplied with iron fishes of various sizes. With these and the heavy planking, &c., furnished in the outfit, there is a large amount of material available for effecting repairs to the spars and masts when necessary, or for rigging jury masts and yards.

THE RUDDER.

Fig. 277, Plate 41, represents the ordinary form of rudder of men-of-war. Around the *pinbles*, A A A, the wood is removed so as to allow the rudder to ship on the *gudgeons*, C C C. In all but the topmost space the wood is removed so as to leave a vacant place, as shown in the figure, but by the topmost pintle the wood is cut square, as seen in the figure at d. This is in order to admit a small piece of oak under the upper pintle after the rudder has been shipped. This piece of oak is called a *wood lock* (d), and is intended to prevent the rudder from unshipping. Under the second





gudgeon a strong cleat is sometimes placed, on which the pintle partly rests. This relieves the gudgeons of much strain.

To Ship the Rudder.-First Method. Bring the rudder under the stern, hung to a scow. Bore a hole through a beam over the rudder case (*i.e.*, the hole in the stern into which the rudder head is inserted), and drive an eye-bolt up; put a washer on and key it. In Fig. 280, *a* represents the key, *b* the washer, *d* the beam, *F* the eyebolt and *E* a top block. Bore a hole through the rudder head, if one is not there already, and drive an eye-bolt through and key it in the hole for the tiller. Then Reeve a pendant through the top block, take it down through the rudder case and hitch it to the eye-bolt in the head of the rudder. To the thimble in the other end of the pendant hook a deck tackle. Take a hawser and make an overhand knot near the middle, Reeve the hawser through the hole in the rudder *H*, Fig. 277, and on the side of the rudder opposite to where the overhand knot brings up make a marlinespike hitch, through which shove a toggle; make a laniard fast to this toggle long enough to reach the deck. Take the ends of the hawser forward to each gangway to act as guys; sway up, guy the rudder fair, so that the pintles are fair for entering the gudgeons, then lower away, fit the wood-lock and bolt it. Come up the purchase, unreeve the guys (hauling the toggle out by the laniard, jerking the hitch adrift and hauling the hawser through on the side of the knot), ship the tiller, Reeve the wheel ropes, shackle the rudder chains, and stop up the pendants.

The tiller of a sailing vessel is shipped in a mortise in the rudder-head. Two pieces of iron, *a a*, Fig. 281, are put on each side of the mortise before the rudder is shipped. The pieces of iron are prevented from coming out by the two shoulders, *b b*. The ends, *c c*, of these pieces, are put through holes in the small vertical projections, *d d*, and are set up with nuts, *e e*. These pieces, called flanges or dogs, prevent the tiller from unshipping.

The band, *fff*, around the rudder-head, is of iron.

Second Method. The rudder for sailing and screw ships differs in the construction of the head; that for the latter being often shaped to receive an iron yoke, Fig. 278. Should there be no beam wherein to place the eye-bolt for the top-block, a pair of sheers, or a stout spar, lashed across the rail over the rudder-hole, may be substituted.

An improved method of securing the rudder chains, is to shackle them to the eye in the extremity of a stout iron bar projecting from the rudder as at B, Fig. 277.

During the Exploring Expedition, the rudder-head of the "Vincennes" becoming so much decayed that the tiller was useless, stout pieces of oak were bolted to the rudder on either side, so as to project similar to B. These "out-

riggers" were connected, by means of luffs, to spars lashed on the quarters, and the vessel steered in that way.

EQUIPOISE RUDDER.

Since the introduction of the screw-propeller and very long ships, the effort has been made to increase the water surface of the rudder with a view to an improvement in steering. The objection to some of these inventions is that the great increase of resistance brings too much strain upon the rudder-head and tiller, rendering the former liable to be twisted off. Still, where the draft is light in comparison to the length, an increase in the breadth of the rudder, over the old pattern, is indispensable.

The most successful design, so far, and one in which the difficulty just stated is overcome, seems to be the pattern known as the equipoise rudder, Fig. 279, Plate 41. In that figure, C E represents the after portion of the keel, D the screw, and A B the rudder, made of iron and working at one-third its breadth, on an iron spindle, or after-stern post *c*. Now, if the helm be put a-starboard, for example, then A C, two-thirds of the entire breadth, present the desired surface to the action of the water, but the strain on the tiller is diminished by the one-third, B C, which acts in conjunction with it, by the water acting on the surface from B to C.

A rudder, unprovided with the usual pintles and gudgeons, whether it be equipoise or of the ordinary type, must be fitted with some arrangement for taking its weight inboard, the spindle at the heel being merely intended to steady it.

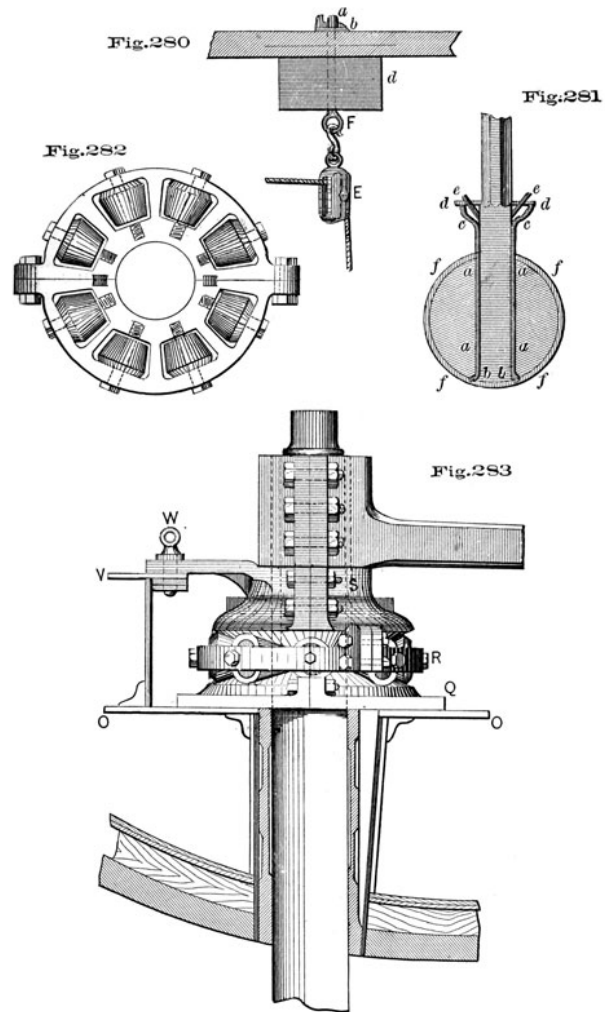
One method of taking the weight of the rudder inboard is shown in Fig. 283, Plate 42.

The four aftermost vertical frames support a horizontal platform, O O, and a circular forging, Q, is secured to the platform, forming a table whose upper surface is beveled, as shown in the figure.

The diameter of the rudder-head is reduced so as to receive upon it a forging, S, and to leave a shoulder above and below that forging. By means of this shoulder the weight of the rudder is transmitted by S to friction rollers underneath it, on a band, R, Fig. 282, so that the working of the rudder is rendered easy.

The after part of the forging S may be formed in such a manner as to overlap the forward edge of a locking plate, V, where, by means of a locking pin, W, the rudder can be fixed at any desired angle.

It has been found that the great area of an equipoise rudder, while adding to the maneuvering power of a vessel under steam, tends to destroy her way when tacking, causes



her to miss stays, &c. Equipoise rudders have, therefore, been designed where the fore part may be locked in its amidship position, leaving the after part alone to act in steering the ship when under sail.

Back-Chains. It is frequently necessary for steamers to back against the helm, but in doing so the strain brought on the rudder and its fitments is immense.

Tug-boats guard against such accidents by using *back-chains*. These are chain pendants which attach to the after-part of the rudder and to some point under the counter, one each side, and of such a length as to give ample support to the rudder when backing with the helm hard over.

Instead of these chain pendants, many tugs and small steam craft have chocks bolted to the rudder-post on each side, and of such shape as to limit the motion of the rudder to an angle of 45° in either direction.

STANDING RIGGING.*

The rigging of a ship consists of a quantity of ropes for the support of the masts, yards and booms.

Each mast is supported from forward by *stays*, from aft by *backstays*, and sideways by shrouds. The foremast is supported in a great measure from the bowsprit, therefore the bowsprit has a number of extra stays, called *bobstays*. These, and such ropes as are stationary, constitute the *standing rigging*.

The standing rigging of modern vessels is composed of wire rope, iron wire rope being in general use, although the substitution of steel wire, owing to its greater strength and lightness, can only be a question of time.

Wire rope now in use in the U. S. Navy for standing rigging, is right-handed, of six strands, each strand having an untarred hemp heart, and another heart in the centre of the rope. The individual wires forming the strand are of a size (larger or smaller) corresponding to the full size of the rope.

In the Navy, all wire rope is measured and designated by its circumference, but bridge builders, and others than seamen, often use the diameter to designate the size of wire rope.

Wire rope is reeled for stowage or transportation on strong wooden reels. To take wire rope off a reel, cast loose the outside end, which is secured to the reel, and make it fast to a bolt in the floor or deck. Place the reel on its edges, with the rope end underneath, roll the reel along the floor to a point a little beyond the length required, then clap on a strap and tackle near the reel, leaving enough space between the strap and the secured end to measure off the required length. Haul the rope taut along the floor, place a mark close up to the secured end. Then measure off from the mark at end the number of feet and inches required. Make allowance for end enough to work either for splice or to turn up, and place within an inch of each other two strong bindings or *whippings* to keep the ends of wire in place when it is sawed off.

* For much of the information concerning wire rigging, our Thanks are due to Boatswain John A. Brisco, U. S. N.

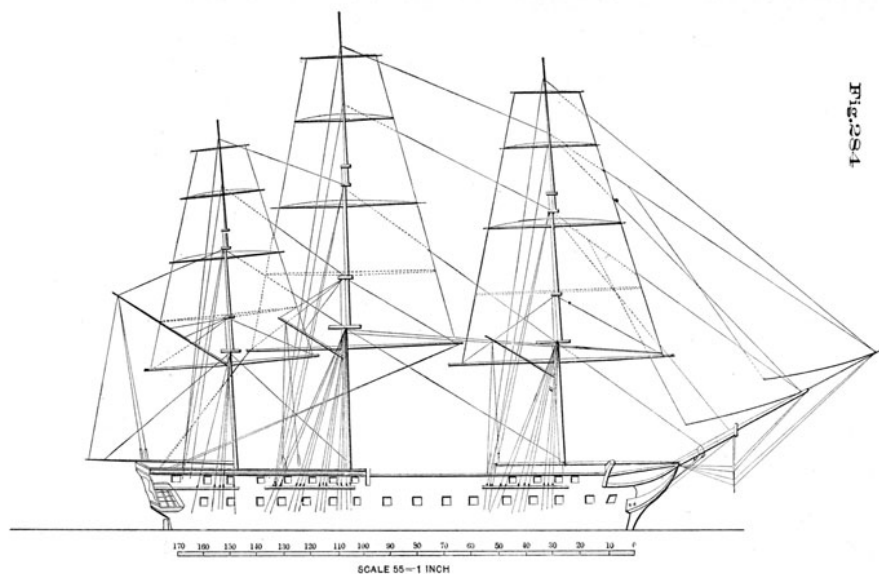


Plate 43

CONSTITUTION.
Half Breadth at Fore Mast to outside of Channel, 20 feet 1 inches,
" " Main " " " " 21 " 2 "
" " Mizzen " " " " 18 " 10 "

If the wire is to be served the full length, it would be better to get it on a stretch before cutting, but if the ends are to be spliced into eyes, then with a hack-saw, kept well oiled, saw the wire in two between the whippings, secure the end of the rope to the reel and put it away.

Should it be required to take all the wire from the reel, then the reel will be rolled as far as circumstances admit, back and forth, till all the rope is off. The rope can then be taken up and put on stretch just as it lies upon the floor without taking turns out for stretching.

A piece of 3/4-inch iron chain, about 3 feet long, with a ring in each end, one ring sufficiently large to let the other reeve through it, is the best strap to be used in putting heavy wire rope on a stretch. Plenty of protection should be put on the rope to prevent the chain from injuring the wire. To apply the chain strap, pass a turn around the rope with one end of the strap, and pass the other end through the ring, and jamb it into place by hand. If it is to be a very heavy pull, a half-hitch can be taken, hook on to the unconfined end and heave taut.

Wire rope, not galvanized, is best protected from weather and wear if painted with boiled linseed oil and red lead, well mixed, and filled well into the lays, wormed and parcelled with cotton sheeting, so cut and laid on that the overlapping will give two thicknesses over all the rope, then painted again and served tight and close over all. If properly done, this will keep out water for years.

Cutting Ribbing by Draft. Having an accurate draft of the hull and spars of a ship, Fig. 284, Plate 43, the measures may be readily taken and the rigging cut and fitted so that it can be sent aloft as soon as the masts are ready to receive it. It not unfrequently happens that a gang of rigging is completed and triced up out of the way, in the rigging loft, long before the ship is ready to take it.

Rigging drafts are usually made on an 1/8-inch scale (one-eighth inch-one foot). This scale is most convenient, because the ordinary two-foot rule can be used as well as any more complicated measure, and the drawing made on an eighth scale is of a convenient size. The largest ship will require a sheet of paper not more than 2 1/2 feet by 3 feet.

The half beam at each mast is usually noted on the draft at the respective channels, but the location of dead-eyes seldom, and therefore the rigger must get the measurements from the vessel. As no beam draft is now furnished, an *adjustable beam scale*, Fig. 287, Plate 45, is employed (which is graduated to the same scale as is the draft) with a sliding rest and set screw. Another adjustable beam scale, Fig. 285, is in the form of a hollow square of metal, graduated on its four exterior sides to different fractional parts of an inch. The sliding rest for the point of the dividers may be applied

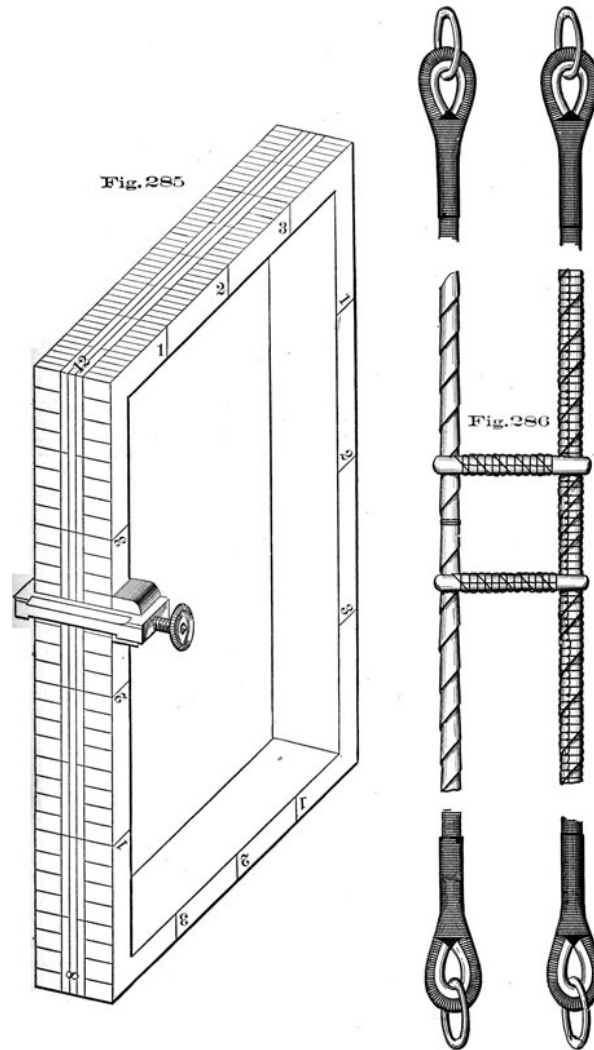
7

to any one of the four sides to correspond with the scale used in the draft.

Before working on the draft scale, measure carefully the square of the mast-head just in line with the upper side of bolster. The measure of the square is used to fit the pendants, but for eyes of the lower rigging, five square of the actual girth measure is used. The mast-heads are rounded for wire rigging, iron or composition plates being let in and secured on each corner of the mast-head to round it off.

Lower Mast-head Pendants. Should be fitted long enough to hang one foot below the futtock band, and both legs are now fitted the same length, with an iron thimble and large link in each end. Fig. 286, Plate 44. The thimble is usually spliced in as close as possible, and for a time it is neat and answers well, but when the service becomes rotten or worn, and requires repairing, the splice is liable to injury in removing the thimble. It would be better to fit the ends with a long eye, so that the thimble can be moved in repairing, and secured in place by a good seizing. In measuring for lower mast-head pendants, find the distance from top of trestle-tree to one foot below futtock band, add one thickness of trestle-tree, and half square of mast-head, which, doubled, will be the combined length of starboard and port leg; add the half length of the round of thimble or length of eye, and a due allowance of end for splicing. Now paint worm, parcel, paint again and serve, and double serve with spun-yarn in the place required for the thimble, splice in the thimble, tucking once whole, once two-thirds, and once one-third. Hammer the splice into a smooth taper, and get the pendant on a stretch by hooking tackles into the links; break off the wire ends close into the lays, give the pendant a good painting, worm from and parcel toward, the centre, serve with spun-yarn, and double serve from centre to a distance equal to one-half the mast-head, together with the thickness and depth of trestle-tree.

With tarred flax parcelling head up from nearly the end of the double service to the centre, and marl on with strong marline, the hitches not more than half an inch apart, being careful to leave a space without hitches at the mark for the cross-lashing, which is to be ascertained and marked before the marling is put on. Having the two pendants spliced, served, headed up and carefully marked for the cross-lashing, let down. From the centre mark of each pendant, lay off and mark each way one half the square of the masthead. Take two pieces of wood about three inches wide and one inch thick, equal in length to one square of masthead, lay the two pendants side by side to verify the marks, then spread them apart till the pieces of wood can be placed across and from pendant to pendant, just outside the marks



where the cross-lashing is to go, allowing room to comfortably work the lashing. With a piece of strong seizing stuff with a long eye, proceed to put on a regular round seizing from pendant to pendant, being careful to keep outside of the mark, or the square will be too small to go over the mast-head. Having passed the riding turns of the lashing, secure its end. Then around the cross-lashing close up to the pendants put a good seizing of houseline, being careful to bring all parts of the cross-lashing close together, and marl the lashing together, parcel with thin stuff and woold with a strand, then with tarred flax parcelling protect the lashing, cover well the turns around the pendants and marl all down. Leave the wooden strips in till the pendants are about to be put over the mast-head.

A link is put into the end of the pendant because it is so much easier hooked into than the thimble in the stiff wire, alone.

The mizzen pendants being made of smaller rope than the fore and main, can be fitted in the same manner, excepting where they are fitted with a cut splice or spanned to a pair of odd shrouds, as is sometimes the case. When pendants are to be fitted in the latter way, the same rules hold good, for the odd shroud and pendants spanned together go on the mast-head first. The odd shroud is fitted straight and passes over the bolsters from side to side abaft, as if it were an after-pendant, and the span is fitted as

above described for double pendants. In small vessels, and when there is no odd shroud, the mizzen pendants are fitted with a cut splice, the cut eye to be one foot longer at each end than the eye for a shroud, with good seizings at the proper places. The eyes are purposely made too large to prevent injury to the splice in opening the eye.

To Measure for No. 1, or First Pair of Shrouds. These comprise the swifter and next shroud, or, as called by riggers, "forward leg" and "after leg," and they go over the mast-head next after the pendants and always on the starboard side.

The beam-scale, Figs. 285 or 287, being adjusted to the mark representing the half-beam of the vessel, minus half the diameter of the mast, place it on the draft just at the upper edge of channel at the dead-eye of the first shroud. Place one point of the dividers at the top line of trestle-tree near the forward side of mast-head and the other point on the beam-scale at the mark indicating the half-beam, apply the dividers to the rule and observe the number of feet and inches it gives according to the scale on which the draft is made; this will give the length of the forward shroud, or "forward leg," of No. 1 pair, without the eye. Then proceed to measure for the next shroud or after-leg in the same manner, moving the beam-scale to the second dead-eye. There will be very little difference in the length of the two

100

first legs, and if any, the after leg will be a little shorter on account of the rake in the mast and the shroud being more perpendicular. Having the length of both legs of No. 1 pair of shrouds, take their sum and add five squares of the girth-measure of the mast-head, *plus* the diameter of the lower mast-head pendants, as the shrouds will "pile," or rise, that much on the mast-head. This will give the extreme length of No. 1 pair.

Having the rope on a stretch, hang it, with tricing lines at short intervals to prevent sagging. Commence measuring from a mark near the strap on the end, the length of the forward leg. Then continue along to measure five square of mast-head, being careful to leave at the centre (which will be the centre of eye) a special mark, usually a long strand. Then measure and mark the after-leg, and in the same manner measure and mark all the other shrouds, not forgetting to add for the second pair of shrouds twice the diameter of a finished eye; for the third pair three times the diameter, &c., as each succeeding shroud must "pile" that much in rising above the others on the mast-head. The first pair of shrouds, or No. 1, being on stretch, measured and marked, worm it and paint from end to end with red lead and boiled oil, being particular to fill well in the lay. Over the worming parcel with new cotton sheeting. In putting on this parcelling commence from the end of each leg, working towards the centre of eye. The parcelling should be so put on that the rope will be protected with two thicknesses at every point; now paint again over the parcelling, and serve from end to end with spun yarn, commencing to serve from the centre and serving in the opposite way to which the parcelling was put on. Measure off from the centre mark each way the half eye (the half of the five square), which gives the place for the upper turn of the eye seizing. Start two feet below these eye-seizing marks, on each leg, and parcel with tarred flax canvas to the centre of eye, and serve over with roundline. Double serve the end of each shroud from the place of the quarter-seizing for its dead-eye. Now let down the shroud and saw off; bring the two ends together and break the eye around till the two eye-seizing marks come firmly together. Mark one foot below the eye-seizing on each leg, and with strong flax parcelling put on the heading, which is just the same as parcelling, always commencing below and working up to the centre on both legs so that the edge of the "heading" will overlap and form a "shingling," which it is often termed. Use the selvage edge of parcelling stuff for shingling, leaving the selvage out; this makes smooth work that will not fray out. Secure the heading in place by marline hitches, which should be on top not more than one-half inch apart, leaving a space for the eye-seizing without hitches.

101

Should there be an odd shroud in the fore or main rigging, it is fitted with an eye-splice, and goes over the masthead last, the eye to be spliced one foot longer than the eye of a pair of shrouds, and seized together above the splice so as to have the same size as it would have if of a pair; the eye to be double served and headed in the same manner as all the others.

Mizzen Rigging is fitted in the same manner as the fore and main, excepting in the case of an odd shroud, which is fitted "straight," passing over across the masthead abaft and forming one leg on each side, being spanned at the mast-head with the pendants, of which the mizzen has in this case but one on each side. In large ships the mizzen lower mast-head pendants are often fitted with four legs, in the same manner as is the fore and main.

Sword mats are substituted for service on the *swifters* (forward shrouds) of lower rigging.

Bowsprit Rigging. Bobstays are now made of iron chain shackled into the cutwater and set up with four score hearts. To find the length of bobstays, measure from the band under the bowsprit at the place prepared for the upper heart, to the bolt or link in cutwater, then find the number of feet and inches the two hearts will occupy and the drift of laniard, add together and subtract the sum from the extreme length; the remainder will be the length of the chains required for the bobstay. Care should be taken that the

bobstays have the same drift of laniard, as it adds to the trimness of the head gear.

Bowsprit Shrouds are fitted of wire and lead well down on the bows, shackled to eye-bolts and set up with three scored hearts. To find the length by draft, measure from the band on bowsprit at the place marked to the place in the bow, and from the extreme measure deduct the drift of laniard and *one* heart. The reason of but one heart being deducted, is that the measure of the other allows for the "carry out" of the shroud. Too much care cannot be taken in fitting the gear and securing the bowsprit, as it not only has all the head booms to support, but in a great measure the foremast with its topmast and topgallant mast, together with the main topmast and topgallant mast.

Fore Stays are fitted with lashing eye collars and set up with laniards and four score hearts. Measure for fore stays from the after-side of foremast head, about one foot above the trestle-trees, to the place where the lower heart is to be.

To form the collar of the stay, allow, in cutting, for *twice* the length of the intended collar.

When cut, unlay one-half (three) of the strands to the mark for the crotch of the collar, keeping each set of strands together. One of the sets will contain the

102

heart. A heart must be laid in with the other three strands.

Form the eye in each leg of the collar by turning back the strands and working *two* of them down to the crotch. The third strand of each set is spliced around the eye and the surplus end cut off.

We then have each leg formed of five strands; each eye formed of three strands.

The length of the collar is usually equal to the length of the mast-head, but may be reduced if necessary to keep the fore yard, when sharp up, from taking against the collar.

Paint, worm, parcel and serve with spun-yarn, parcel again with flax, and double serve with round-line; fid out each eye and insert a strong hard-wood toggle. Get the stay on stretch by lashing the toggles to posts four or five feet apart, get a strong tackle on the end, heave it up straight and trim the splices. Paint, worm, parcel, paint again, and serve with spun-yarn from end to end, being careful to have a good piece of parcelling laid through the crotch to shed the water. Then, from four feet below the crotch, parcel with tarred flax parcelling to eyes of collar, and leather over the parcelling, serving over the ends of the leather and over the splices. Having both stays double served and leathered, place one over the other, being careful to keep the crotches fair and even. Then seize both stays together with one good heavy seizing close up to the crotch, and smaller ones at every two feet along the collars. Parcel and leather over the seizings. Double serve the ends of fore stays to eight feet above the nip around the thimble.

Main Stays are fitted in the same manner as fore stays, excepting the double service on end, which is only from quarter seizing around thimble to end. Sometimes if the smoke-stack, when up, is near the stays, a piece of chain is shackled into the stay just over the stack. The main stays generally set up with four scored hearts, the lower heart being secured to iron straps made for the purpose, one on each side of the foremast. The iron rods or straps lead down to the berth deck, frequently passing through the bitt standards and setting up with a nut on the forward side.

Mizzen Stays are always single, with the collars fitted and lashed, same as fore or main stays. On some vessels the end is split into two legs to admit the main trysail mast, and each leg fitted with a thimble to set up by laniard to bolts on each side of main-mast. On others the end is turned up around a thimble and set up with three score hearts to the after-side of main-mast.

The ends of all stays turn up *under* the standing parts.

The ends of all shrouds turn up *inside* the standing parts.

Futtock Shrouds are made of rod iron set up with turn-buckles. The required lengths are best obtained

by actual measurement after the top is on. In small ships futtock shrouds are rattled down. Futtock shrouds are set up independently to the top rim, and not to the plates of the topmast dead-eyes. The lower ends secure to the futtock band.

NOTE.-In the above measurements for shrouds it is assumed that by measuring from the place of the lower dead-eye, on the channel, enough allowance is made for turning up the shroud around the thimble of the upper dead-eye. But if the drift of the laniard added to the diameter of both dead-eyes does not allow enough shroud to turn up, extra length must be added for that purpose to each measurement taken.

The amount allowed for turning up is six feet for the forward shroud of large rigging, a proportionately smaller amount for smaller rope. After shrouds have somewhat more turn up than forward ones, in order to bring the ends themselves parallel to the sheer.

Upper dead-eyes are usually in line with or below the rail.

When lower rigging has been set up for some time, or after a ship has experienced heavy weather, it will be found that the shrouds will not lie exactly above one another, but settle, the necks of the eyes working partly inside of each other. The effect is to slacken the rigging, particularly the after shrouds, which settle most, and which may require turning in again to keep the dead-eyes in line, a difficult operation with wire rope. If the allowance for piling were two-thirds of a diameter of the shrouds, instead of a whole diameter, as at present, it is believed that much of this inconvenience could be avoided, although a few of the after dead-eyes might not come quite to their places when the shrouds are first set up.

Topmast Rigging. To measure for topmast shrouds from the scale draft, proceed on the same principle as for lower shrouds. Set the beam scale to one-half the spread of the top from the side of the mast, allowing for the rounding of the top; place the beam scale on the draft abreast of the proper dead-eye, and measure the distance with dividers from the top of the sliding rest to the top of the trestle-tree. Add for each pair the spread of the trestle-trees, and make the usual allowance for turning up from the nip of the dead-eye thimble.

Topmast rigging is fitted in the manner known as "*straight*," with one eye formed out of two pairs of shrouds, which gives two "lifts" or thicknesses on the mast-head, with four shrouds on each side, making a snug and neat mast-head.*

* This answers very well for ships intended to do most of their cruising under steam; but cannot be recommended when sail is to be carried to any extent. All the strain comes on the seizing.

104

It should be painted, wormed, parcelled, painted again, and served the entire length. The shrouds double served from centre of eye to three or four feet below the futtock-staff. The length of heading from centre of eye down to one foot below the eye-seizing is put on the same as for the lower rigging.

Catharpins are of wire rope, wormed, painted, and parcelled, and double served throughout; fitted with eyes in each end, and go abaft the mast and seize together in the centre.

The topmast-head (burton) pendants are wire rope, fitted with a shackle in one end and a link in the other; the shackle connecting to a link under the trestle-trees. Each topmast has four pendants, two forward, and two abaft the rigging. The lower ends of pendants hang six inches below the catharpin legs.

Pendants are fitted the same as topmast rigging, without double service, except around their thimbles.

Sword mats are substituted for double service on the swifterns of topmast rigging.

Topgallant Shrouds. The easiest way to measure for length of topgallant shrouds is to draw a figure to scale, showing the top, the position of the futtock-staff, and position and spread of cross-tree. Measure on that draft from the topgallant mast-head to the horn of the cross-tree, thence to futtock-staff and into the top, where the shroud sets up. Allow for each pair enough for a neat eye around the funnel, and ends for turning up.

The shrouds are painted, wormed, parcelled, painted again, and served the entire length, and go over the funnel on the mast-head. They are fitted in pairs, with eyes formed like the eyes of lower rigging, and seized so as to fit snug over the funnel.

The forward legs are double served from the centre of eye to one foot below the futtock-staff of topmast rigging; the after leg is double served from centre of eye, three feet down; then from a point one foot above cross-trees to one foot below the futtock-staff: both legs are leathered in the wake of cross-trees, and set up in the top with dead-eyes.

Royal Shrouds, Stays and Backstays. Measure for each to where it leads and sets up, allowing enough end to turn up in the wake of the thimble.

Fore.-Are painted, wormed, parcelled, painted again, and served the entire length, and fitted to an iron funnel or band, which has three eyes at equal distances apart, one on each side and one forward. The shroud and backstay are one piece, rove through a side eye of the band and seized around a thimble there. Double service one foot down on the shroud and backstay from centre of eye, double service on the shroud, leathered in the nip of the jack. The stay is spliced around a thimble on the forward eye of the band

105

double served and leathered in the nip of the flying jibboom, in the clamp on the dolphin striker, and also where it reeves through the bees on the bowsprit.

Royal shrouds set up in the top with a purchase; stays and backstays with dead-eyes.

Main.-Fitted and set up the same as the fore; double service and leathered at the nip of the chock in the fore-topmast trestle-trees.

Mizzen.-Fitted and set up the same as the main; double service and leathered at the nip of the chock in the main-topmast cross-trees.

Fore-topmast Stays. Measure from after part of topmast-head to the bees, thence to place of setting up; make allowance for turning up. They are fitted separate; single service throughout; collars the same as fore and main; double service from ten feet above the bowsprit to one foot inside of the leader under the bees; leathered over double service from four feet above the bees to eight inches inside the leader, under the bees. Set up with three-scored hearts.

The service on the port (*spring*) stay is omitted in the wake of the stay-sail hanks.

Jib Stay. Measure from after part of topmast-head to where it leads and sets up. To be fitted like fore-topmast stays, with split collars, lashing-eyes, &c.; served from four feet above the boom to the end where it sets up; double service and leathered in the nip of the clamp on the dolphin-striker, and also where it goes through the bees, leathered over the surface from four feet above to eight inches below the boom; collars of jib and topmast stays seized together below the crotch around the stays, seizings parcelled and leathered. Set up with three-scored hearts.

Main-topmast Stays. Measure and fittings similar to fore-topmast stays; in long ships, with great distances between fore and main masts, they may be brought directly to the deck near the foremast;* but in short ships they pass through chocks between the fore trestle-trees, and set up on deck with three-scored hearts. Nips double served and leathered; collars seized together in the loft.

Mizzen-topmast Stay. Measure and fittings similar to main-topmast stays, and set up in the main-top with three-scored hearts.

Fore-topgallant Stay. Measure to where it leads and sets up, allowing for neat eye-splice around funnel. Painted, wormed, parcelled, painted again, and served the entire length; double served on the eye around the funnel, and from twelve feet above to one foot below the jib-boom; also in the wake of the nip of the clamp on the dolphin-

* It would be better if this lead could be adopted in all ships, but the smokestack frequently interferes.

106

striker, and where it reeves through the bees, or leader under the bees. All nips to be leathered. Stay set up with dead-eyes.

Main-topgallant Stay. Measure and fit like the fore, and set up with dead-eyes in the fore-top. Double served and leathered at the hole in the fore-cap through which it leads, also leathered about three feet below the crotch of the eye-splice.

Mizzen-topgallant Stay. Measure and fit as above. Served, leathered, and led through a hole in the main-cap and set up in the main-top.

Flying-Jib Stay. Measure and fit with an eye-splice, similar to topgallant stay. Double served; served and leathered three feet below the crotch of splice, in all other respects fitted like the jib stays. Set up with dead-eyes.

Jib Guys are of wire rope, painted, wormed, parcelled, painted again, and served the entire length; double served and leathered in the wake of whiskers, over which they fit with horseshoe cringles; outer ends shackle to a band on the boom end; set up to the bows, or cat-head, with three-scored hearts.

Flying-Jib Guys are of wire rope, fitted, set up to the bows, or cat-head, with three-score hearts, and connected with the boom, same as jib guys; reeve through thimbles in a strap out on the whisker yard-arms. Double served and leathered in the nip of the thimbles.

Whisker-Jumpers are of wire rope; painted, wormed, parcelled, painted again, and served throughout; fitted with an eye-splice, double served and leathered, to fit over the whisker-boom end; the inner end leathered in the nip, and set up on its own part through a bull's eye connected to a bolt on the cut-water.

Back Ropes are fitted of hemp, served throughout, hooked or shackled to the dolphin-striker, and set up at the bows with three-score hearts.

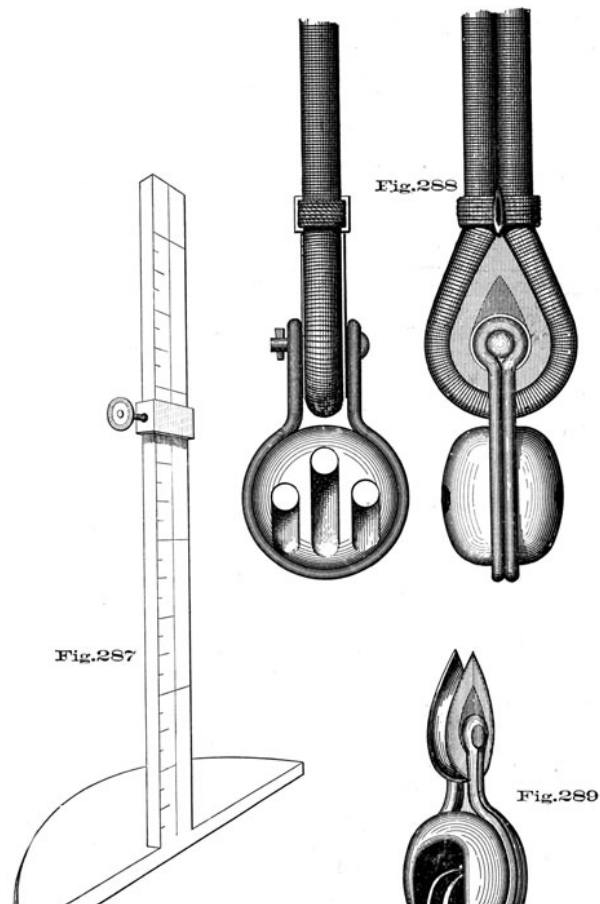
Jib Martingale-Stay is of wire rope, wormed, parcelled, and served the same as guys. Fitted with shackles and thimbles in each end, with double service around the thimbles. Shackles to the dolphin striker and to the band on jib-boom.

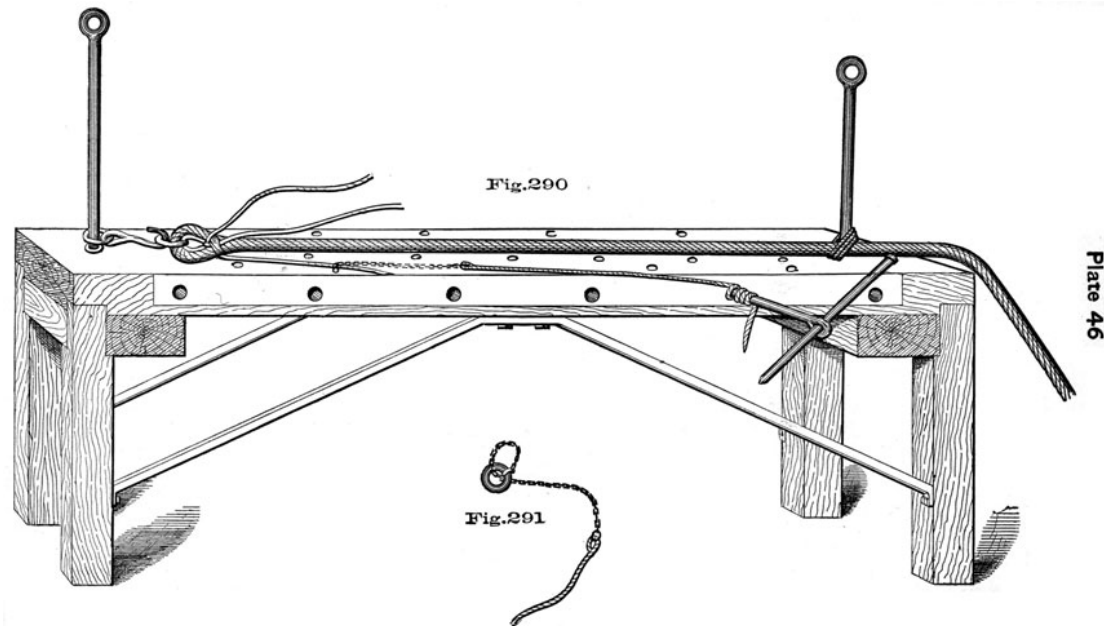
Flying-Jib Martingale-Stay. Fitted the same as the jib martingale, of wire; double served around the thimbles in the outer in the wake of the sheave on the dolphin-striker, and where it reeves through the bees, or leader. Sets up with dead-eyes.

Fore and Main Topmast Backstays. Fitted and measured off the same as the after-shrouds of the fore and main rigging.

Mizzen-Topmast Backstays are fitted with horseshoe eyes, or, properly speaking, a span. Measured like the fore and main.

Plate 45





Fore, Main, and Mizzen Topgallant Backstays are painted, wormed, parcelled, painted again, and served throughout. Fitted with spliced eyes, which are double served, without outside parcelling. Measured from the funnel to the place of setting up in the channels, with allowance for the eye and the usual allowance for turning up.

For the rules for finding size of shrouds, see Appendix C.

Boat-Davit Topping Lifts, Spans and Guys, are of wire rope, and served throughout. Spans to which topping-lift pendants are attached are leathered in the middle.

Dead-Eyes. The dead-eye now used in the Navy is shown in Fig. 288. Plate 45.

The end of the shroud passes around a heavy iron thimble, which is confined by a pin to the lugs of the iron strap of the upper dead-eye.

Dead-eyes are made with one hole without a score on the inboard face, the edge being left square so as to present a solid shoulder to the knot of the laniard.

The shroud being passed around the thimble is secured by five seizings-throat, quarter, middle, upper and end seizing.

The two lower turns of the throat seizing are racking turns, over these come riding turns. The seizing is crossed and hitched in the upper part.

The quarter, middle and upper seizings are riding seizings.

The end seizing is flat, crossed and hitched, and holds into place the canvas *cap* placed over the ends of all standing rigging.

Lower dead-eyes connect with the chain plates by bolts, so as to be readily unshipped. The bolts are fitted with forelocks.

In setting up stays and some other portions of the standing rigging, scored hearts are used instead of deadeyes. These hearts have iron straps, and the upper ones are supplied with iron thimbles similar to those around which a shroud is taken. Fig. 289, Plate 45.

Care must be taken in turning the ends of shrouds or stays around their thimbles that it is done properly, as, in the event of a change becoming necessary, it is difficult to get the old nip out of the wire.

All wire rigging in the Navy sets up with hemp lariards, which impart all the "give" necessary.

Topmast rigging of fore and aft vessels may be set up on end.

For turning in old-fashioned dead-eye, see Appendix C.

The Splicing Bench. Fig. 290, Plate 46. For convenience in handling wire rope, some rigging lofts are supplied with splicing benches, which are large tables of hard wood, plated with iron on the top and sides.

108

The top of the bench is pierced with holes, into which may be set steel standards or "normans," by which the rope is steadied on a stretch. Similar holes are made in the sides of the table to receive smaller pins.

In splicing, for instance, a link and thimble into a large wire rope, the rope itself is steadied between two normans at opposite ends of the bench. A hook, fitted with a ring which slips over the norman head, is hooked into the link of the thimble around which the rope is to be spliced.

When a strand has been stuck once, a small chain strap, Fig. 291, Plate 46, with a ring in the chain end and tailed with manilla rope, is clapped on to the strand. The strap leads off to the side of the bench in the direction to be taken by the strand. The rope end of the strap is there taken around one of the projecting pins and hove upon, by converting the pin into a Spanish windlass.

A like purchase is used on every strand after sticking, varying only the lead of the strap. As the sides and top of the bench are pierced with suitable holes, the lead of the strap can be changed in a moment by shifting the position of the pin used.

In Fig. 290, some strands are omitted to avoid confusion.

A *turning in machine* for wire rope, Fig. 292, Plate 47, is supplied in rigging lofts and aboard ships to shape wire rope when turning in thimbles, or wherever it is required to make a short nip.

In splicing wire rope proceed as with hemp, sticking once whole, once two-thirds, and once one-third; get it on a good stretch and break off the wires close to the rope by working them quickly backwards and forwards.

In splicing an eye with more than three strands, the second left-hand strand is tucked from right to left under the first convenient strand.

Take the precaution when the marlinespike is entered under the strands where you wish to put in the first tuck, to beat the strands on either side of the spike with a hammer, so as to keep them open until the strand is entered.

To splice a thimble in wire rope. Red lead, parcel and serve the rope in wake of the thimble. Break the rope around the thimble, stop the parts together, pass seizings around the rope and through the thimble to hold the latter in place. Then open out and splice.

Besides the marlinespike; pincers, files, cold chisels and saws are useful in the manipulation of wire rope.

Metallic Splices. A new method of splicing wire rope is being introduced by which the end of the wire rope is inserted into a metallic socket and there secured by pouring a strong fusible metal around it, filling all the spaces in and around the rope, and forming a solid and firmly united structure.

The sockets may be terminated by any kind of device commonly used in connection with wire rope. A round-eye socket is used to replace the eye-splice around a thimble, and similarly sockets with bull's-eyes, sister-hooks, or deadeyes are made for use in connection with this process of splicing.



In the figure is shown a longitudinal section of a round eye socket, showing an arrangement of inside notches into which the filling metal sets, increasing the strength and safety of the splice.

This method of splicing has been favorably reported upon, the results of tests showing that the patent splice is stronger than the common splice, and stronger than the rope itself; also that it is durable, more quickly and economically made, and that it presents a neater appearance.

To make the Metallic Splice.

First, Measure the depth of socket and cut the same length from the hemp heart of the rope.

Second, Have a sufficient quantity of filling metal being melted.

Third, Insert the end of rope into the socket, and hold it in a horizontal position over a strong heat until a piece of the filling metal will melt when held on the *upper* side of socket, and until the rope becomes too hot for the hand at three inches distance from the socket. Have the filling metal hot enough to ignite a shaving or piece of paper when brought in contact with it.

Fourth, Place the splice with the rope inserted in an upright position and pour the socket full, and let it remain in position until cool, when it is ready for use.

The Kind of Filling to Use. Pure tin, or a compound of half lead and half tin, or the latter compound with two per cent. of antimony added.

The following tests of the metallic splice were made at the Watertown Arsenal, August 22, 1881:

SOCKETS	STEEL WIRE ROPE	ULTIMATE STRENGTH.
Malleable Iron	Two inch	20,900 lbs.
"	Three inch	45,700 lbs.
"	Four inch	73,000 lbs.

The rope was broken in every case and the splices were uninjured.

[← Previous Part](#) [↑ Seamanship](#) [Next Part →](#)
[Home Page](#)

CHAPTER IX.

RIGGING SHIP.

WHEN a ship is taken in hand to be rigged, her lower masts are standing, temporarily or permanently wedged, and with girtlines on each side of the mast-heads. The bowsprit is in place, as are also the lower dead-eyes for the lower rigging. Hearts on the bowsprit and shackles on the bows may also be supposed in place before the riggers begin work.

We will rig the bowsprit first, as the staying of the fore-mast depends upon it, and would otherwise be delayed.

The Gammoning of the bowsprit in modern vessels consists of one or two iron straps as shown in Figs. 293 and 294, setting up with nuts and screws. It serves to keep the bowsprit in place, and should be set up before the ship is turned over to the riggers.

Secure the heads of two small spars together in a lashing hung from the bowsprit-end, the heels resting on the bows, where convenient, and seized to prevent slipping. Lay boards across from one boom to the other as a platform for the men to stand on.

The Bobstays are placed first, shackling to the cutwater, and with laniards from hearts in their outboard ends to similar hearts under the bowsprit. There are two, or three, bobstays fitted; if three, they are termed *inner, middle, and cap* bobstays.

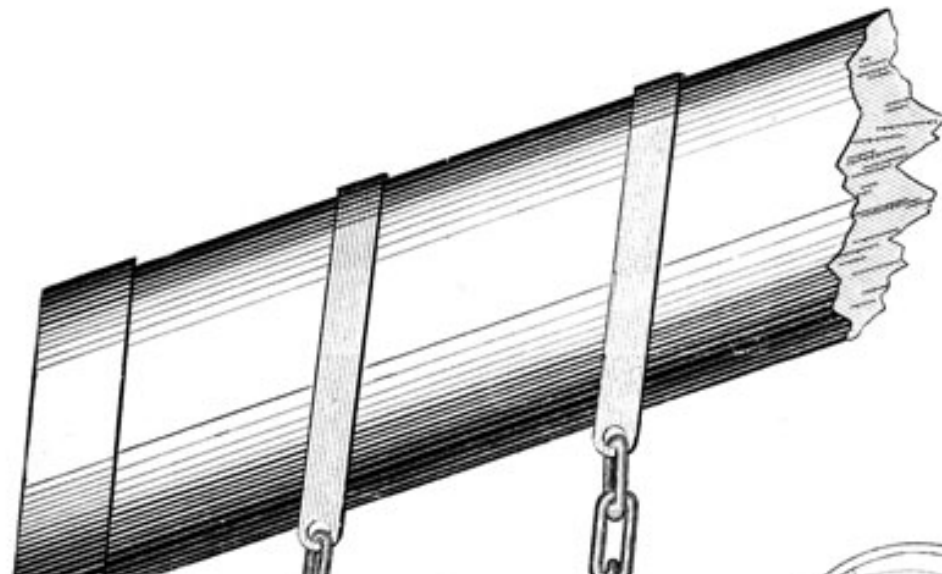
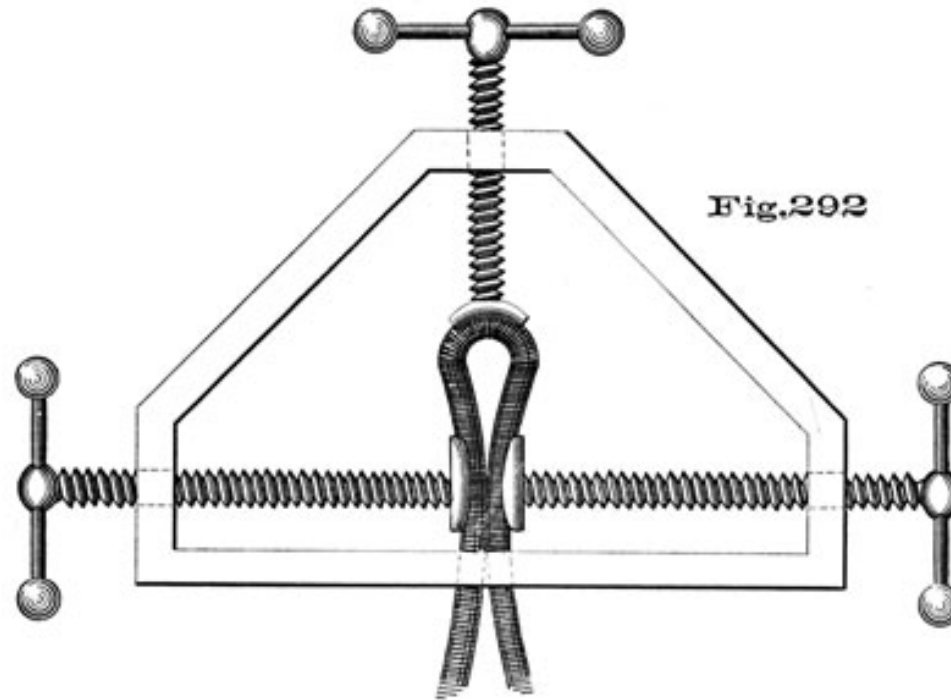
Bowsprit-Shrouds. Shackle the bowsprit-shrouds one on each side to eye-bolts, well down on the bows. The hearts in their outboard ends set up with laniards to similar hearts on either side of the bowsprit near the cap.

Now set up the bowsprit-shrouds and bobstays. Both may be set up by using luff upon luff on each end of the laniard, as in Fig. 301, racking every turn after it has been hove taut, and finally seizing down the ends.

This is termed "setting up on a bight," and the object is to keep the hearts from slueing. Or, secure one end of the laniard and set up on the other, one turn at a time, by means of stout luffs hooked into a strap on the laniard and into another strap on the standing part of the bobstay or shroud. Fig. 302.

Laniards for wire rigging are of the same size as

Plate 47



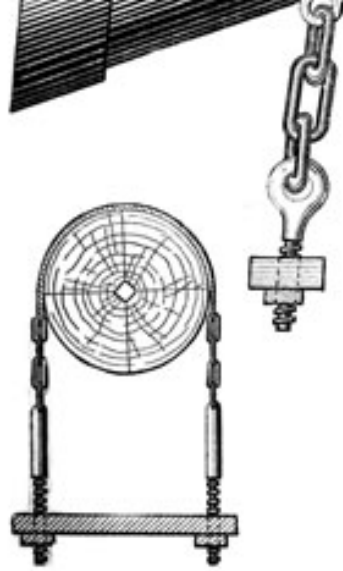


Fig. 293

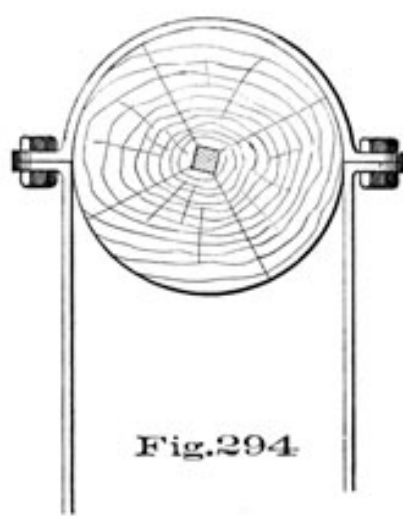


Fig. 294

Fig.295

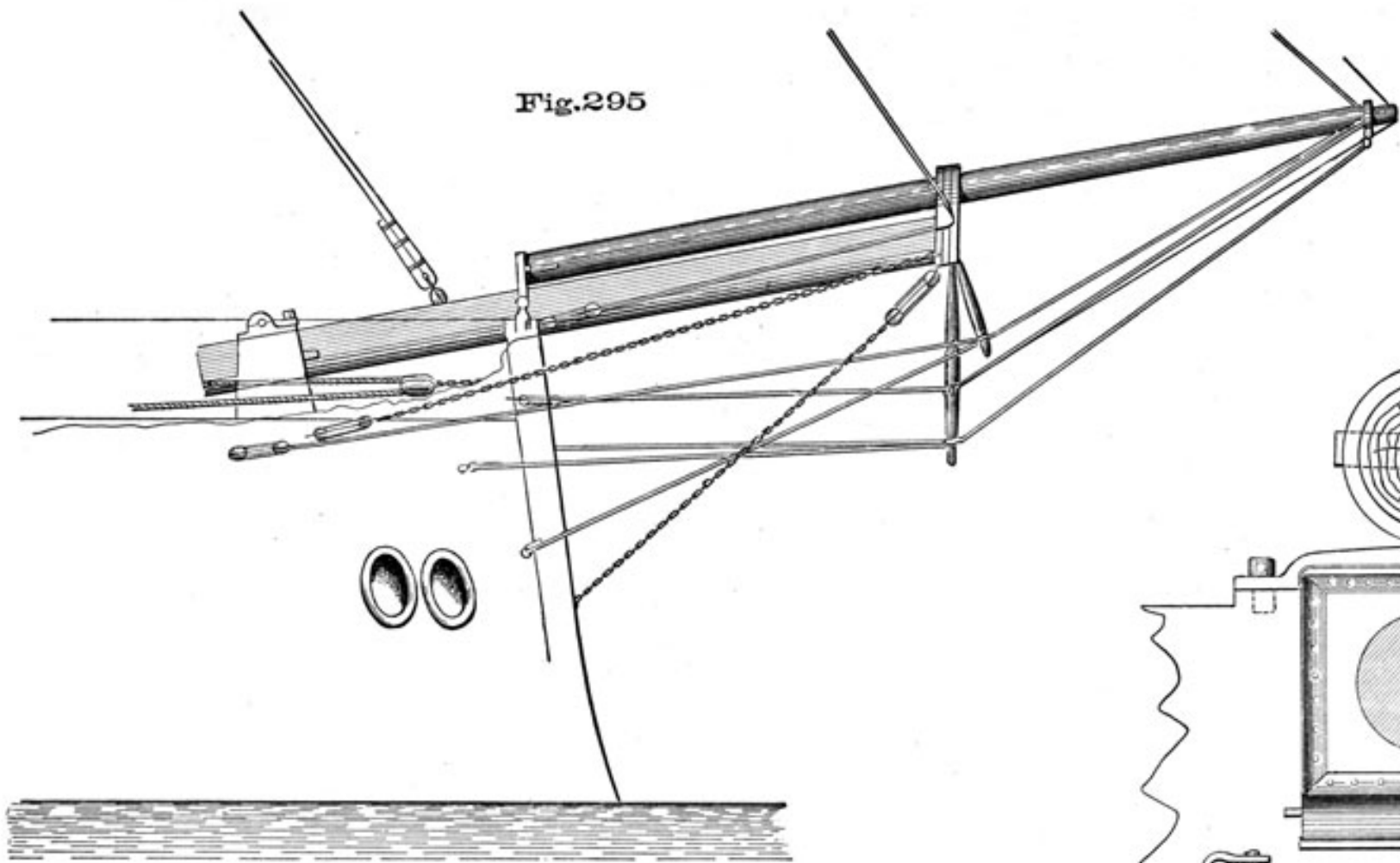
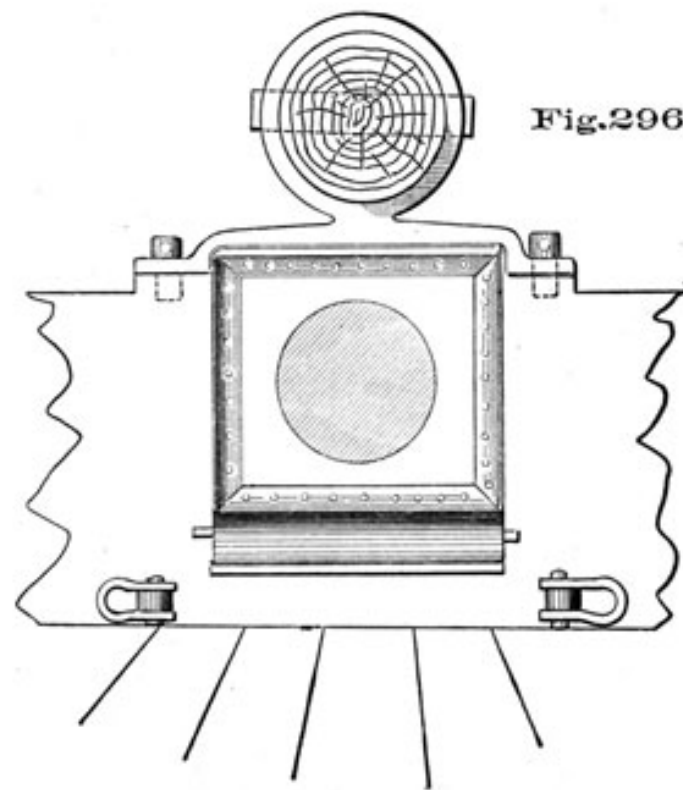


Fig.296



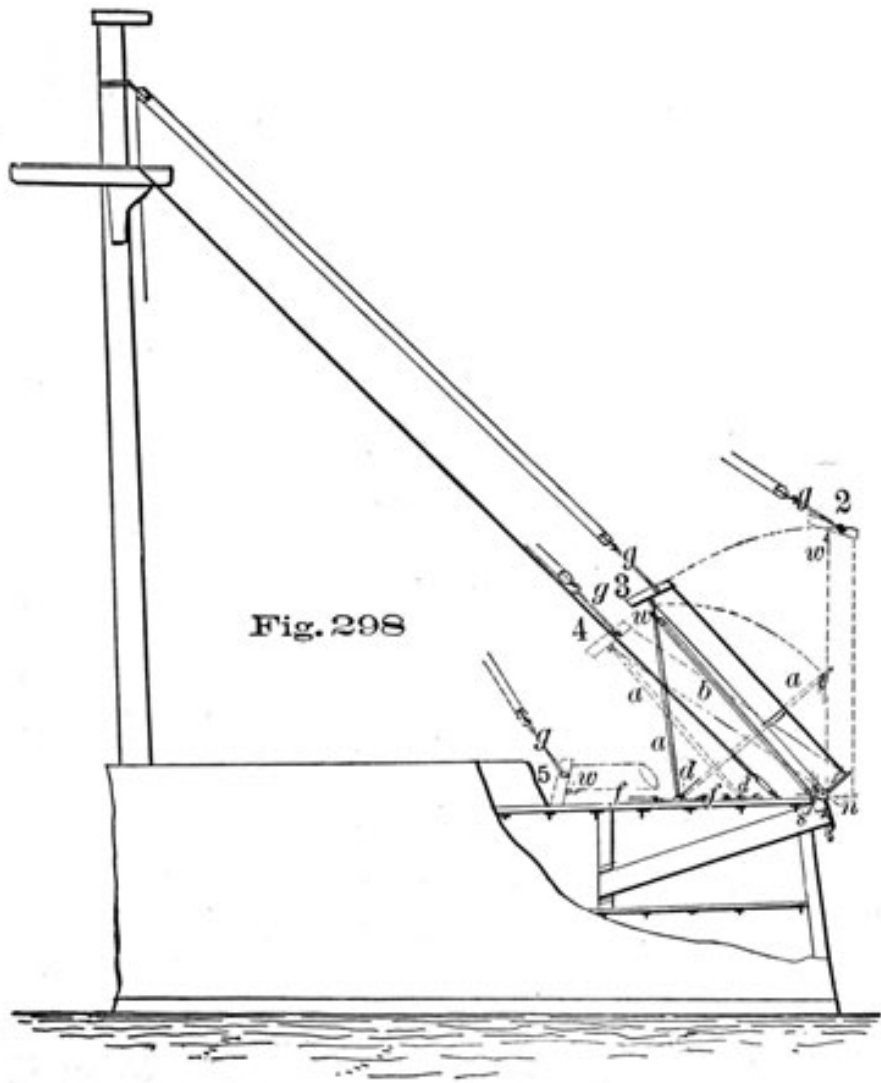


Fig. 298

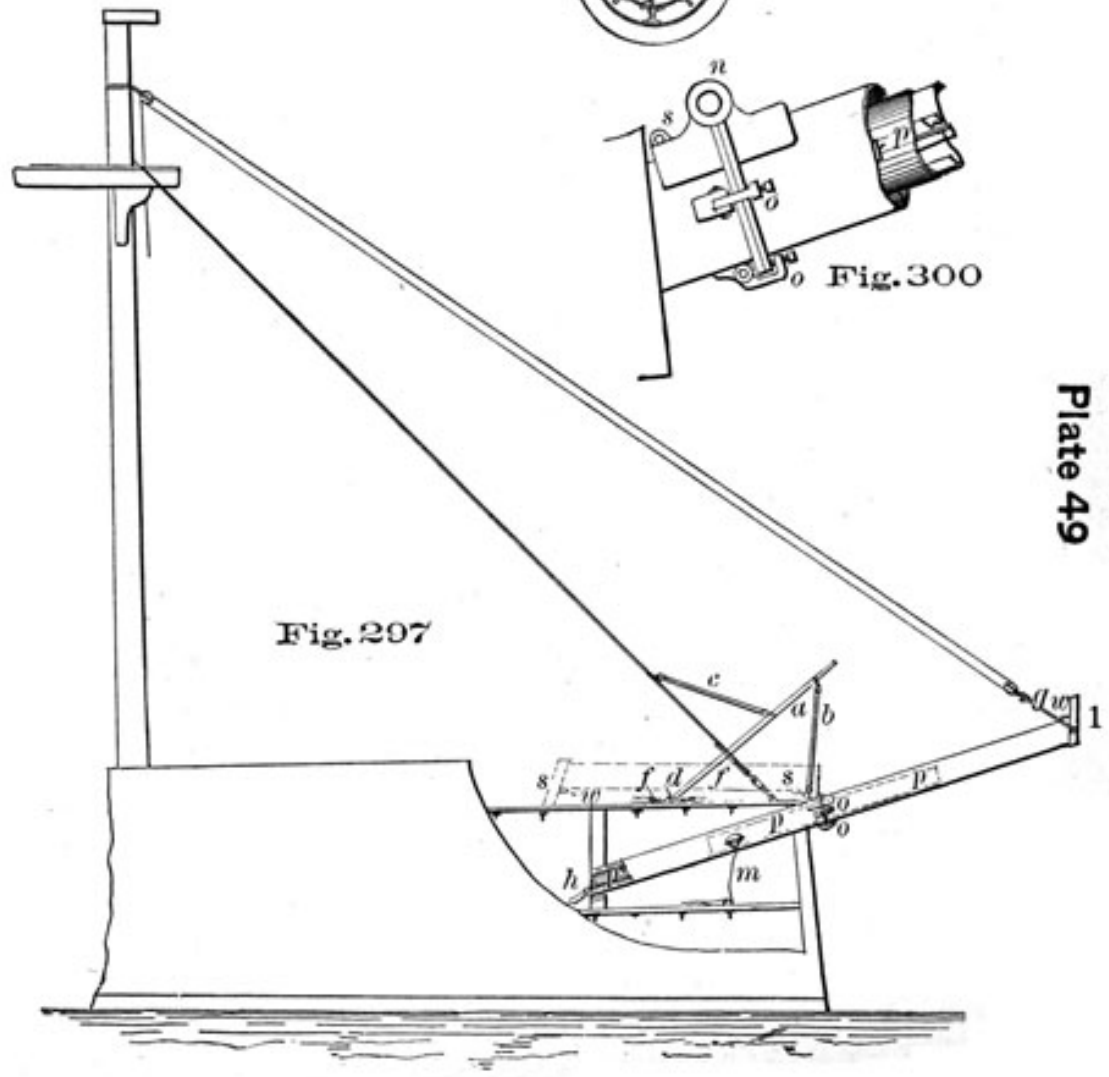


Fig. 297



Fig. 299

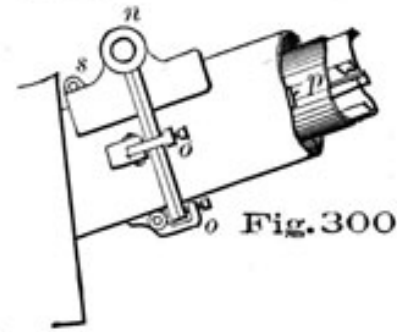


Fig. 300

the rigging itself; for hemp rigging as used formerly, laniards were one-half the size of the corresponding shroud, stay, &c.

Laniards are four-stranded hemp. It is considered better to clap straps on the laniard when setting up than to turn in catspaws, either with or without toggles thrust in them, as the strap does less damage to the laniard and does not nip it out of shape. All straps should be smaller than the rope around which they are taken, to insure a good hold.

Rigging-in Bowsprit. When a vessel is fitted as a ram, the bowsprit and jib-boom must be so arranged as to be readily gotten out of the way in clearing ship for action. For this purpose the bowsprit is either fitted to rig in, or to be lifted clear of the bows.

Fig. 295 shows the general arrangement of a rigging-in bowsprit. The spar is rectangular in section, and projects horizontally; its rigging is simplified as much as possible. The bobstay and fore-topmast stays go to the cap or to a strap just inside the cap; the forestays set up inside the rail, and the bees are dispensed with. The bowsprit runs in on the forecastle, as shown in the figure, being held in position when rigged out by a fid forward of the heel bitts, temporary gammoning and a boom-iron (fitted with interior rollers) at the bows. The heel of the jib-boom secures in a clamp above the bowsprit-iron, Fig. 296.

Lifting Bowsprit. Where there is no pivot-gun on the topgallant forecastle, the bowsprit of ram-bowed vessels may be fitted to *lift* inboard, this plan being suggested by Admiral Porter.

Fig. 297 shows the general arrangement of such a bowsprit; Fig. 298, the process of lifting; Fig. 299, a section of the bowsprit and *plunger*, and Fig. 300, the hinge, &c.

The bowsprit proper is of iron, and in the general detail of its form, stiffness, &c., is similar to the iron lower masts previously described. It is hinged just outside the rail at *n*, and secured when in place by the screws *o, o*. The bowsprit cap has secured to it on each side the ends of a heavy *bail, g*, large enough and with a motion sufficient to pass around the bowsprit-cap from the upper to the under side of the bowsprit.

The plunger is an iron cylinder inside the bowsprit, made up of plates, secured with the usual stiffeners of angle-iron, and equal in length to the inboard end of the bowsprit. It is rigged out by means of a heel tackle, *m*, and sheave, Fig. 297, so as to project, inside the bowsprit, about half its length beyond the rail. It slides in and out on bearings formed by the inner surfaces of the bowsprit stiffeners.

Its purpose is to strengthen the bowsprit in wake of the hinge *n*.

bail on the cap, upper block lashed to the foremast head below the lower cap.

A derrick, *a*, is raised on the forecastle by means of a tackle, *c*, from the fore stay. The heel of the derrick pivots in a shoe, which travels on a fore and aft guide track and is fitted with stout fore and aft tackles, *ff*. A derrick head purchase, *b*, has its upper block on the derrick, lower block hooked to an eye, *s*, on the bowsprit just abaft the hinge. The derrick-head has jaws like those on the inner end of a gaff.

Having rigged in the plunger by means of a tackle, *h*, hooked to its heel, slacking the heel rope, *m*, the clamps at the bowsprit hinge are come up, and the head of the bowsprit triced up to the position 2, Fig. 298. Here the bail is nearly fore and aft, and about to swing over the end of the bowsprit. The head of the derrick, *a*, by means of its jaws, assists in supporting the bowsprit until it reaches the position 3, tending the derrick-head purchase. From 3 to 4 the heel of the derrick is shifted forward by the shoe tackles from *d* to *d'*. Here the bail and pendant tackle, having shifted around to the under side of the bowsprit, take up the weight again and land the bowsprit in position 5, Fig. 298.

Lower Masts. Proceed now to rig the lower masts, and send up first the trestle-trees, as follows:

Trestle-trees. The mast-head girtlines should be stout enough to send up the trestle-trees; if not, send up heavy whips on each side, and lash their blocks at the lower mast-head, over the tenon or just below it. The men required to work aloft are sent up by the girtlines.

Place the trestle-trees on deck, forward of the mast, Fig. 307, and take out the after chock, as the forward one, by having to support the heel of the topmast, is more securely bolted and not intended to be removed. Hitch the ends of the whips to the *forward* ends of the trestle-trees, and stop down on the top side, along to the after ends. Bend on a guy from forward, sway aloft, and as the after ends of the trestle-trees rise above the bibbs, cut the stops and work them into their places. Send up the after chock and bolt it.

Whole Tops are sent aloft with the two girtlines used in sending up the trestle-trees, and a good-sized single or double tackle, hooked to a strap abaft the mast and directly between the girtlines, as in Fig. 308.

Place the top on the deck *abaft* the mast, with the forward part uppermost. Overhaul down the girtlines and tackle, pass the ends of the former underneath the rim and make them fast to their own parts, around

the after-part of the top, stopping them out to each girtline-hole, as in Fig. 308. Hook the lower block of the mast-head tackle to a stout strap around the after-part (to which a guy is also attached, *leading aft*), and secure the *standing parts* of the

Plate 50

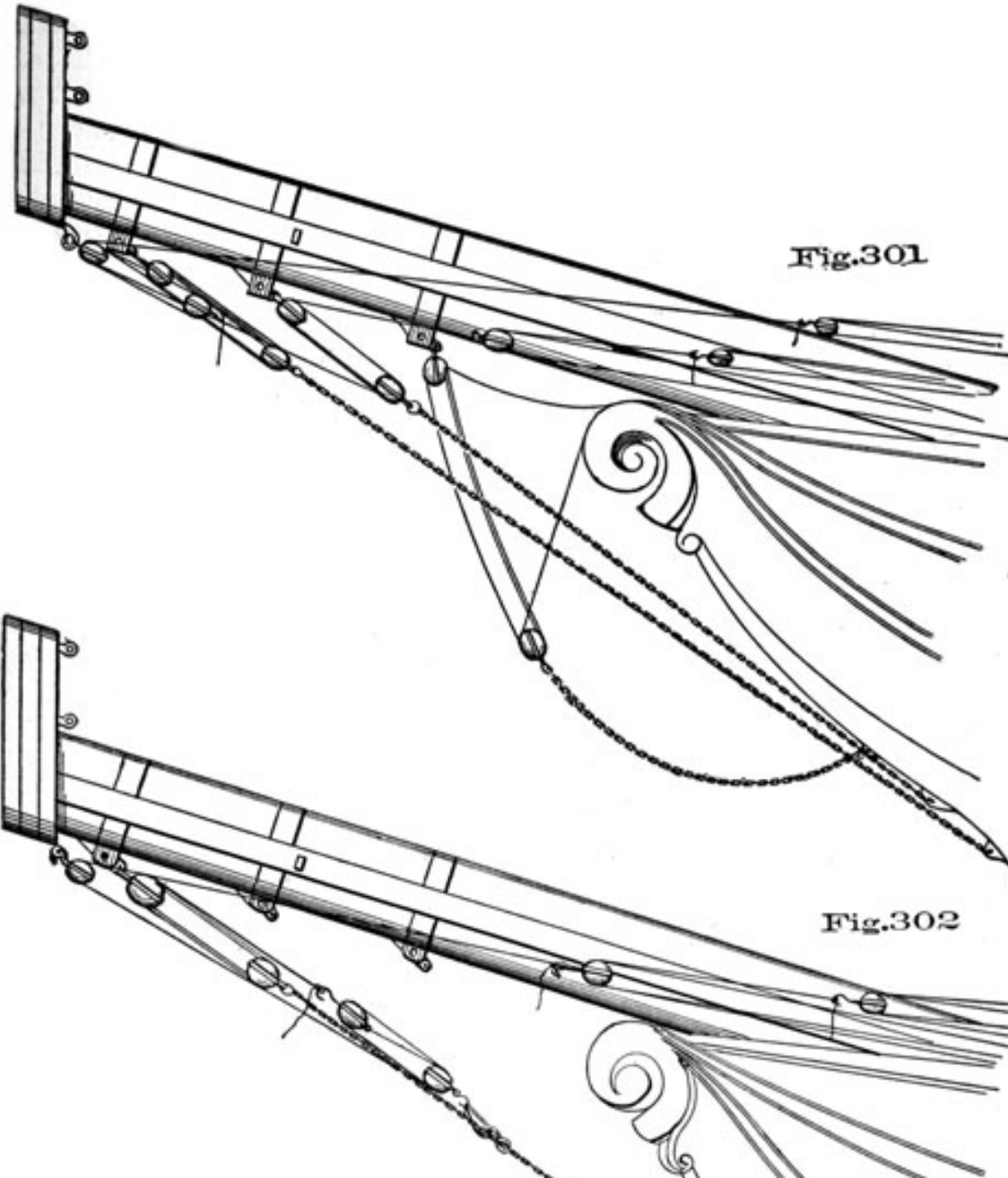
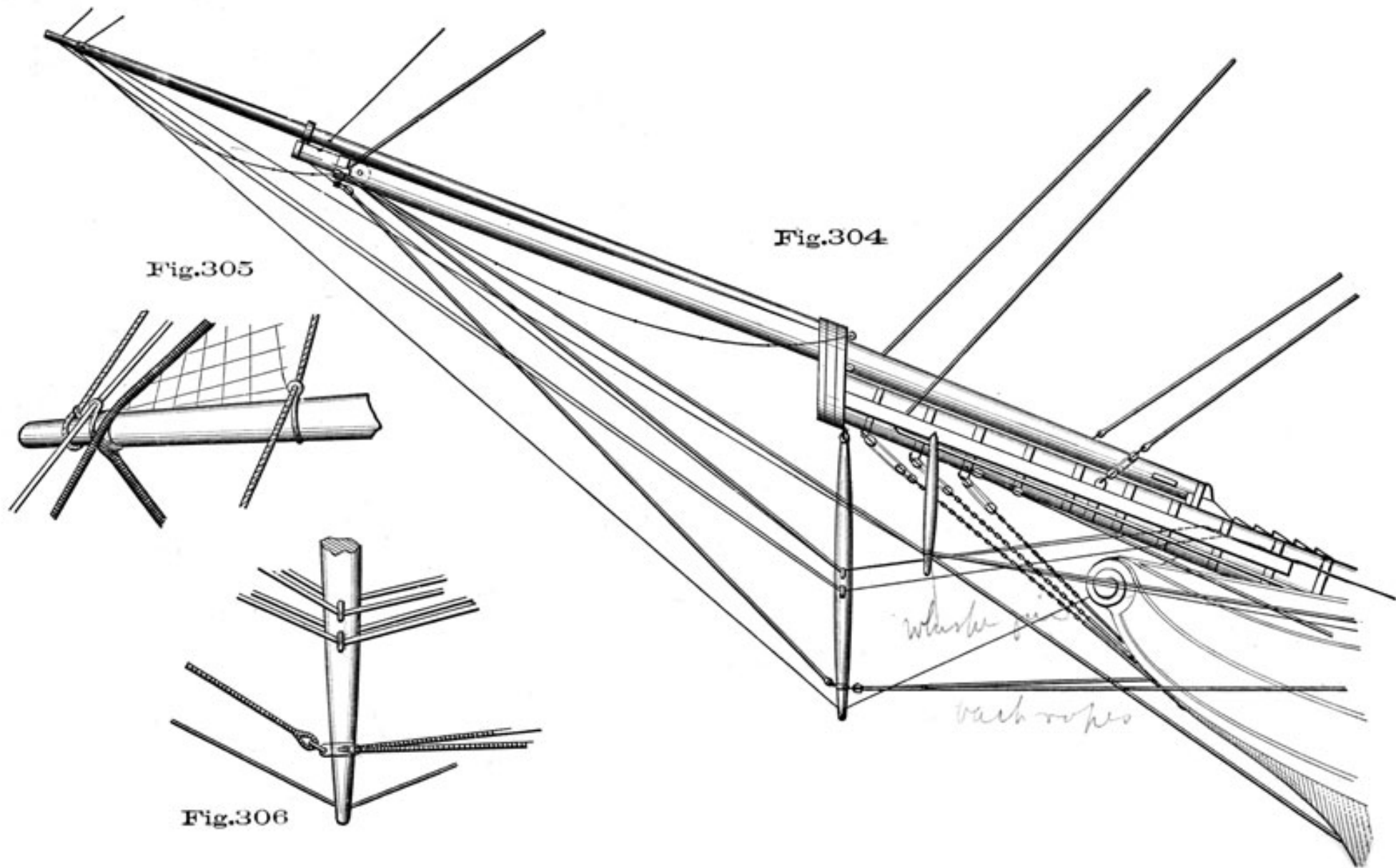




Fig.303



tackle and girtlines to the pigeon-hole by means of a squilgee-toggle, over which the bights are laid. Bend on a tripping-line to the toggle (which should be greased), man the tackle and girtlines and sway away, pulling up steadily on all. When the forward rim comes up to the block, jerk on the tripping-line (which disconnects the parts and permits the girtlines to go out to the side, and lead off fair); sway on the tackle until the lubbers-hole is clear of the mast-head, and lower away by means of the girtlines, sending the top aft or forward with the tackle and guy as need be. The cross-trees are either secured to the top before sending it aloft, or sent up by means of the girtlines first.

Half Tops. The half tops are placed on deck with the *outer* rims uppermost, on their respective sides of the deck. Pass a strap or lashing around the centre of each, steadying it in its place by a small lashing through one of the futtock holes. Overhaul down the whips used in sending up the trestle-trees, and bend each to the strap around the half top of its respective side. Sway the halves up close to the blocks, and let them hang there until the cross-trees are sent aloft and bolted in their places. Then lower the halves down and secure them; sway up the upper cross-trees and bolt and confine the whole with iron bands. Fig. 309.

Now send up and place the bolsters, which are made of soft wood and covered with three or four thicknesses of tarred parcelling, and then get over the lower pendants, which are swayed up by the girtlines. If the mast needs support while the rigging is being sent aloft, the pendant tackles may now be hooked and hauled taut, but they are dispensed with, if possible, as being very much in the way.

Lower Rigging. As the routine of rigging is nearly identical on all the masts, the method for the *fore* will answer for a description of the others.

In the merchant service, as soon as the lower pendants are over, the lower mast is steadied by the pendant tackles, the topmast is pointed about four or five feet above the lower mast-head, and to it are attached the girtlines for the shrouds, after the manner of a derrick. Navy-yard riggers proceed as follows:

To Send up the Shrouds. In heavy ships, two girtlines will be required to support the weight of the shroud; the block of the main girtline being toggled to the *midship girtline-hole* in the top; the second, or "short" girtline, being at the mast-head tenon and worked in the top. Send hands aloft with marline-spikes, tar, slush, commander,* &c.

Now proceed to get the shrouds up, and over, in the

* Commander; a large wooden maul.

order of their succession, Fig. 310. *Knot* the ends of the main girtline together, and fit a toggle in one part, just above. Thrust this between the two parts of the first pair of starboard-forward shrouds, from *out, in*, somewhat more than the length of the mast-head below the eye-seizing, and put a stop around both parts to retain the toggle in its place. Stop the girtline along the shroud towards the eye, and at the *crown*, and sway aloft. When as high as the top, bend on the short mast-head girtline just below the eye-seizing, taking the end from *in, out*, and stop it as in the other case. Cut the lower girtline adrift, as the shroud comes up, and steady it to the hand of the man aloft, who will bear the eye over the mast-head, and cast off the upper girtline. Place it fair and *beat it down with the wooden commander*, being careful to carry the shroud well aft, as the angular action of the strain, in setting up, has a constant tendency to bring it forward.*

Send up the port forward pair in the same manner. We might now rouse the legs of the shrouds well down *amidships*, i.e. in a line parallel with the mast, to give the eyes, a good on the bolsters, and set up all four legs at the same time, with the pendant tackles, to ensure getting the eyes well down, in place. But this is seldom done, and we proceed, as a rule, to get over the other pairs of shrouds in their proper order without stopping to set up. It is well to remember that too much care cannot be taken to beat the eyes well down in their places at once, and in this connection attention may be called again to the effect of the eyes settling down at the mast-head, and the means suggested in the previous chapter for avoiding slack after shrouds.

To Send up the Fore-and-aft Stays. All the shrouds having been got over, shift the girtlines from the top up to the mast-head, and lash them to the sides and well aft. Dip them down through the lubber's hole, and bend the starboard one to the fore-stays below the crotch, stopping it to the starboard legs; bend the port girtline on in the same manner to the port legs, and sway aloft, cutting the seizings as the legs reach the top, Fig. 312. Use a third girtline overhauled down forward of the top, and bent to the stays below the crotch, to assist in raising the stays. Pass the collar-lashings (one end of each lashing is spliced into one of the eyes of its stay), and either rest the collars on the lower rigging or on a heavy cleat sometimes placed for the purpose on the after side of the mast. The stays are now seized around the thimbles of their upper hearts, if this has not been done in the rigging loft; the

* It will save trouble aloft if the eye of the shroud is bent forward before going up, and stopped to the legs, which lays it fair for going over. Cast off the stop from the legs when the eye comes through the lubber's-hole, and use the stop to assist in hauling down the eye when over. Fig. 311.

Plate 52

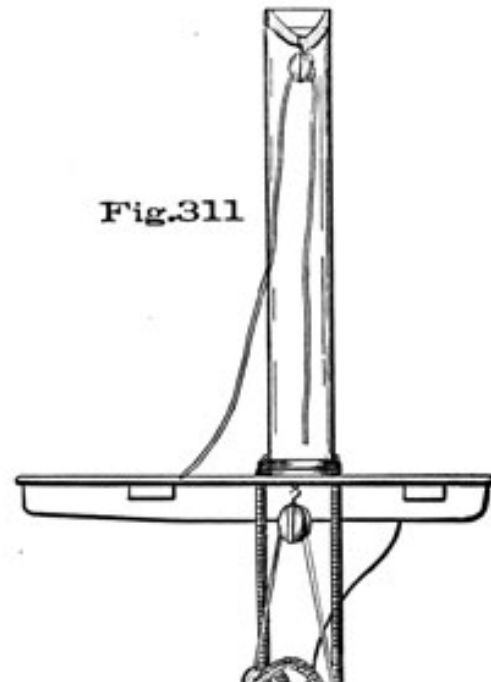
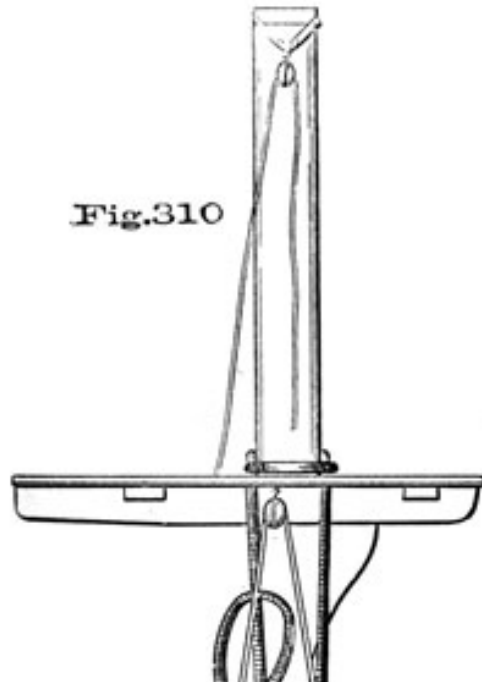
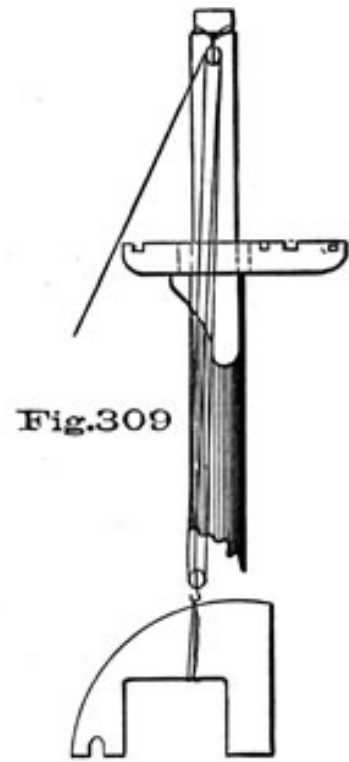
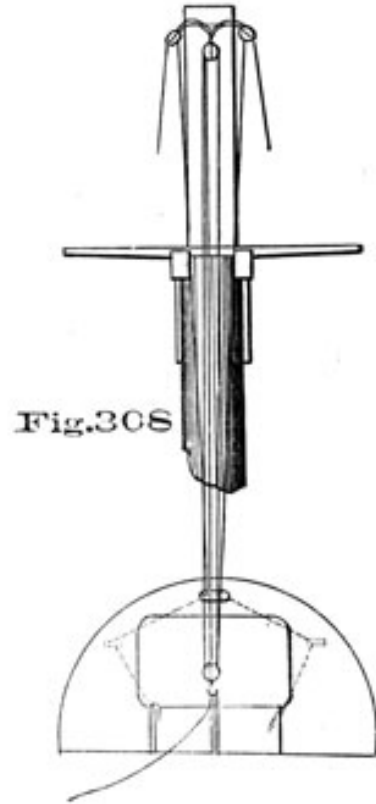
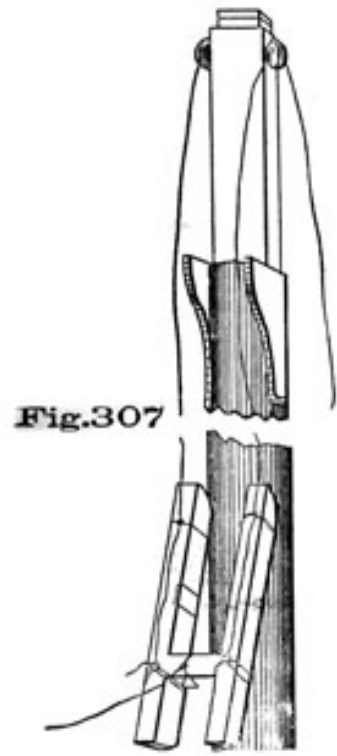




Plate 53

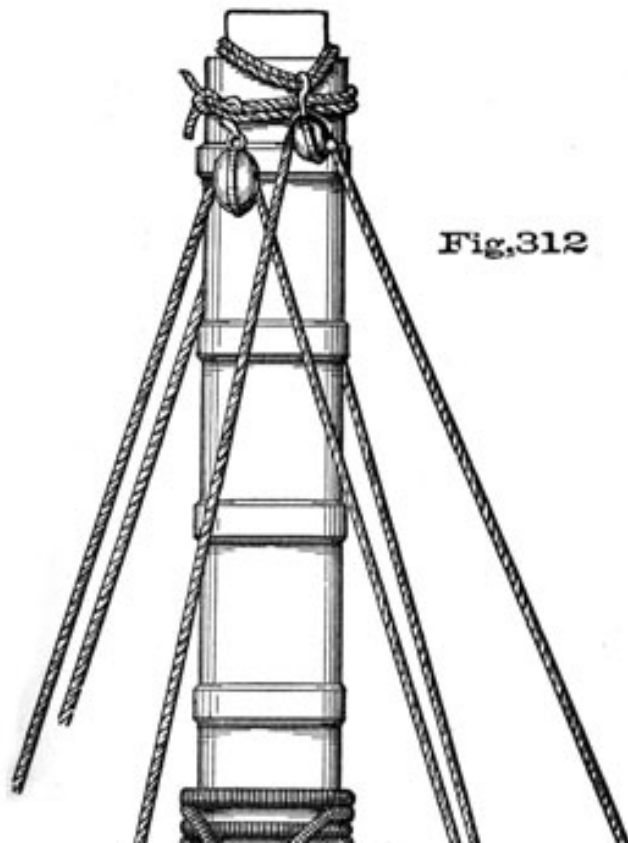
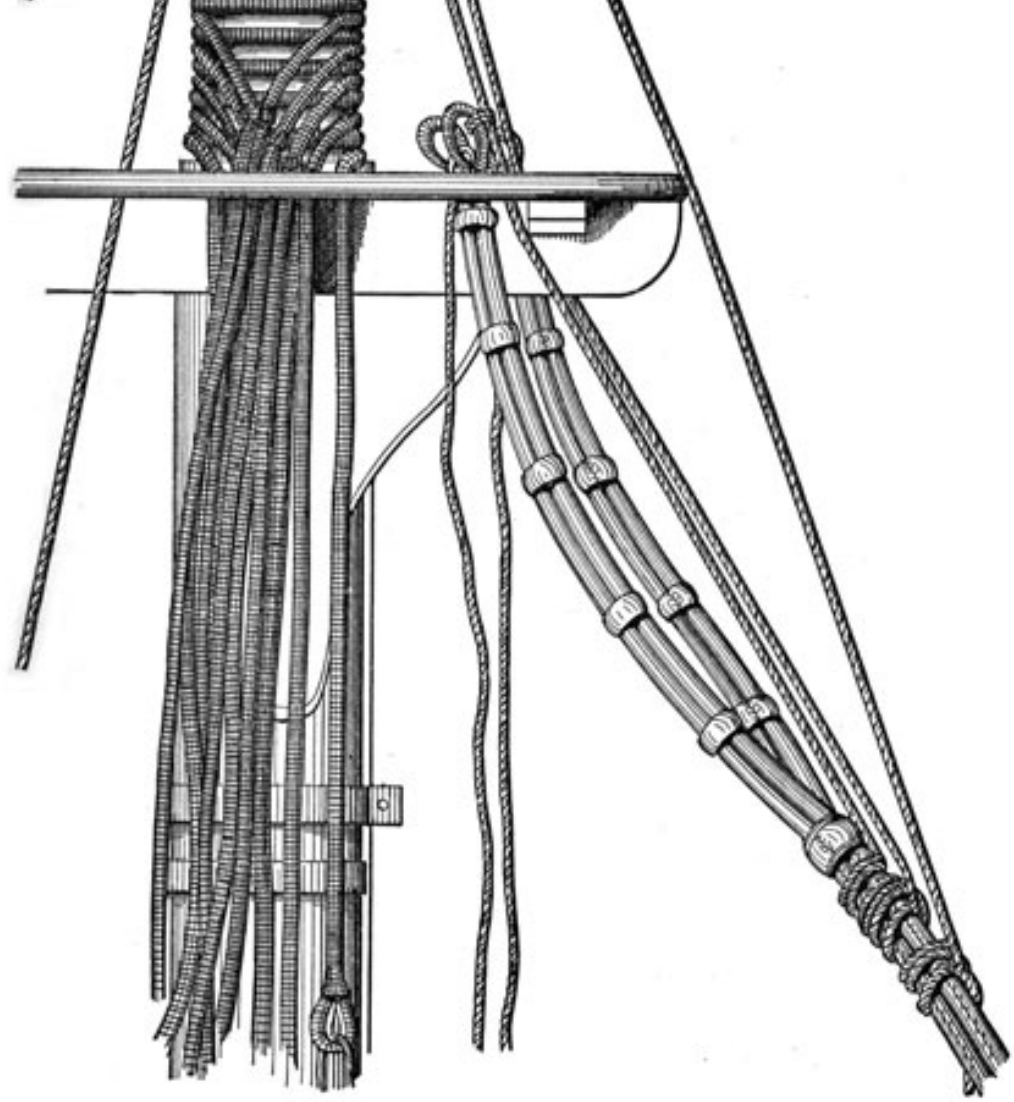
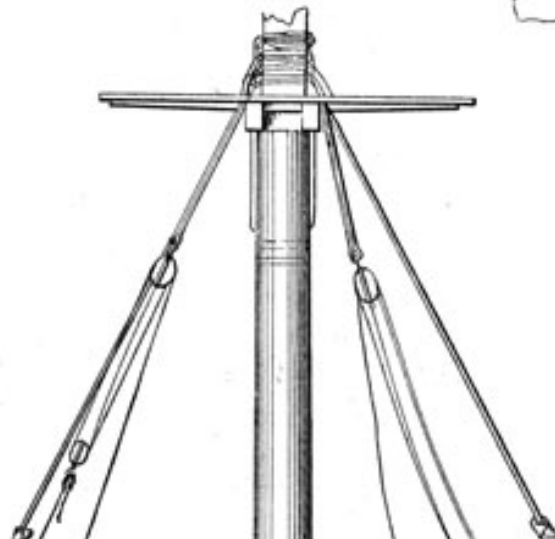
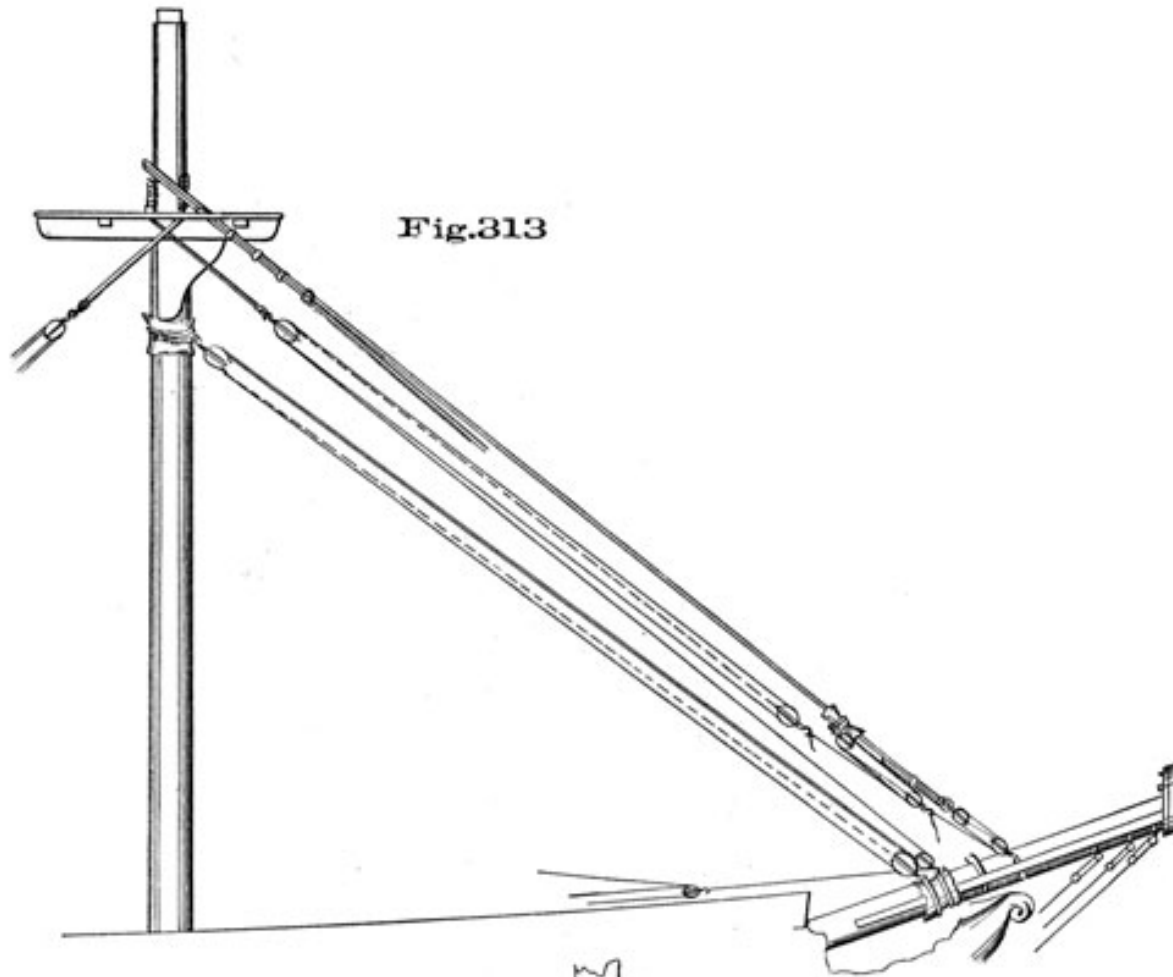
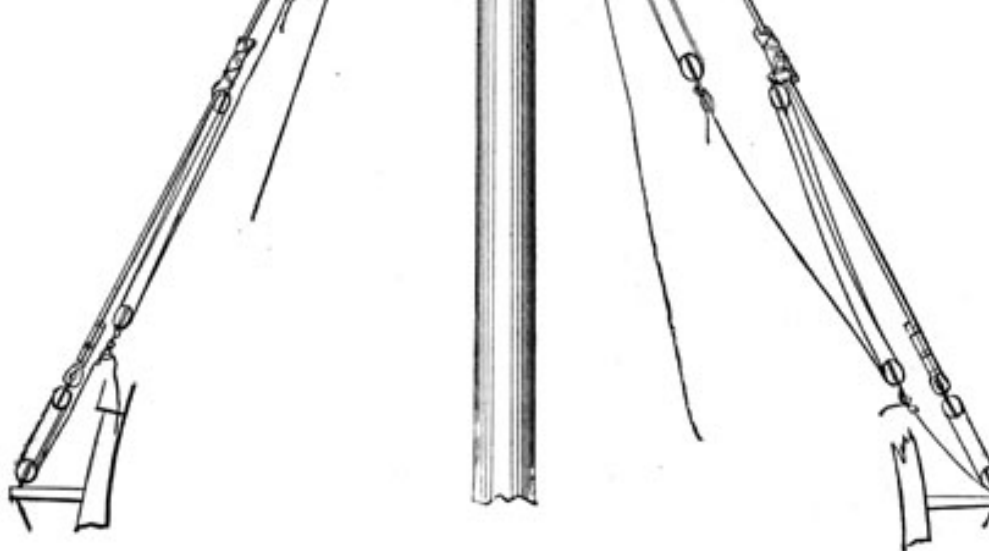


Fig. 312







lower hearts should be found in their places shackled to the fore-stay straps on the bowsprit. These straps are iron bands passing around under the bowsprit; one end of the strap has an eye for the heart, and the other an eye for the forelock which secures it. Reeve off the stay laniards.

On the Standing of Masts. Experiment proves that by raking masts *forward*, in a vessel of ordinary form, we increase the tendency to pitch, besides increasing the difficulty of trimming the yards on account of their confinement when *by* the wind. The vessel is given an increased readiness to *wear*, but with a corresponding indisposition for coming to, and an increased need of *lee* helm to keep her to the wind. In scudding, this disposition to fall off increases the danger of being brought by the lee.

When masts are stayed *perpendicular* to the keel, the wind acts in a horizontal direction on the sails, and the objectionable features of the preceding plan are avoided.

Finally, when masts rake *aft*, there is an increase in the after sail of the ship, a disposition to approach rather than recede from the wind, the tendency to pitch is obviated, and the difficulties of bracing due to forward staying are avoided.

The general custom is to stay the foremast plumb, or with a rake aft varying from 1/4 to 1 inch to the foot, the mainmast raking 1 1/4 inches to the foot, and the mizzen 1 1/2 inches to the foot.

Staying the Foremast. The foremast is stayed by means of a double purchase leading forward to the bowsprit, and two pendant tackles hooked to the forward legs of the pendants, the after pendant tackles being set up to eye-bolts well aft. Fig. 313.

With these purchases and the wedges eased up, the mast can be stayed either plumb or with a slight rake, as required. The amount of rake, if any, is determined by the constructor, and a plumb-line is made to plumb the deck at a distance from the after-part of the mast equal to the amount of the rake for the length of the plumb-line used. If the line is hung from the mast-head, seventy feet from the deck, a rake of half an inch to the foot should cause it to plumb the deck thirty-five inches from the after-part of the mast, &c. Lateral staying is effected by measurement with a small line, secured at the centre of the after-part of the mast-head and carried to the water-ways on either side in line with the after-part of the mast. Masts may also be stayed by the use of battens, as explained in Appendix D. Buckling a lower mast and getting it out of a vertical plane are by no means uncommon, and, in the absence of a practised eye, the suggestions in the Appendix will be found of value if at any time the rake of a lower mast requires altering. In

such a case the preparations above described for staying must be made and the wedges knocked out.

The mast being in the right position, belay and rack the falls, put in the wedges for a full due; and put on the mast coat, which is used to keep the water from rotting the mast at the partners. It is made of heavy canvas and painted, and covers the heads of the wedges and the mast up to eighteen inches above the deck.

To set up the Lower Stays, Fig. 313. At a distance eight or ten feet up the stay clap on one block of a "stay luff" (double purchase), having canvas underneath to avoid chafe, and hook the other block into a strap on the stay laniard. Into the fall of the stay luff hook the lower block of a pendant tackle, and having got the stays taut, rack the laniards and proceed to set up the shrouds.

To set up the Shrouds. The laniards are fitted in the rigging-loft, having a *laniard knot* (a Mathew Walker knot showing two or three parts) cast into one end. This knot rests against the unscored hole in the upper deadeye, which is *forward* in the starboard shrouds and *aft* in the port shrouds. Reeve off the laniards through the upper and lower dead-eyes, the hauling end always coming up from the lower dead-eye.

Place canvas on the shroud about half-way up to avoid chafe, and tail the upper block of a *rigging luff* (gun tackle purchase) over it. Hook the lower block of the luff to a strap on the end of the laniard, and

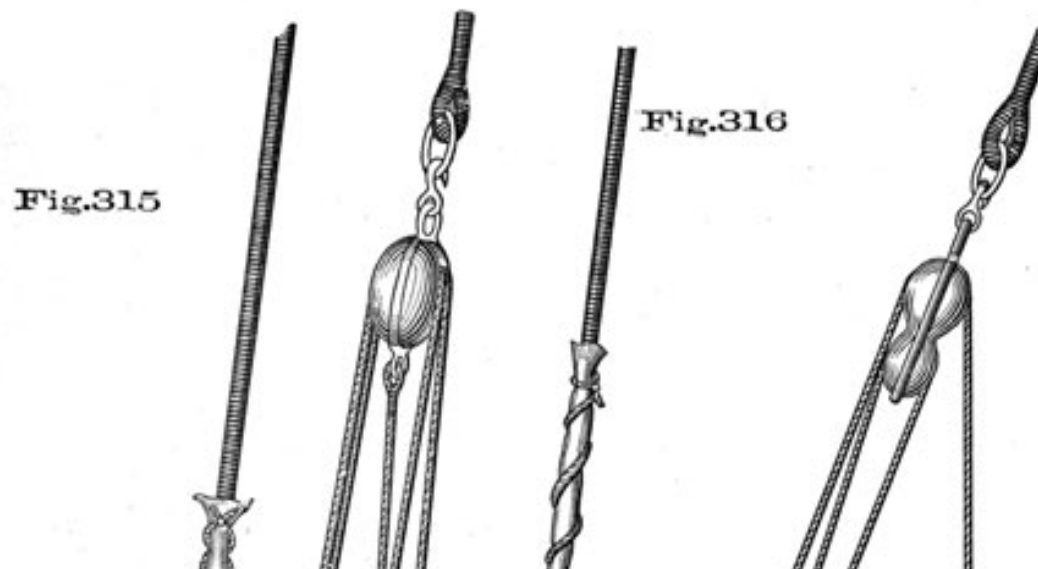
lead the fall of the luff up to the pendant tackles as in Fig. 315. The luff tails should be dogged on long so as not to nip the shroud.

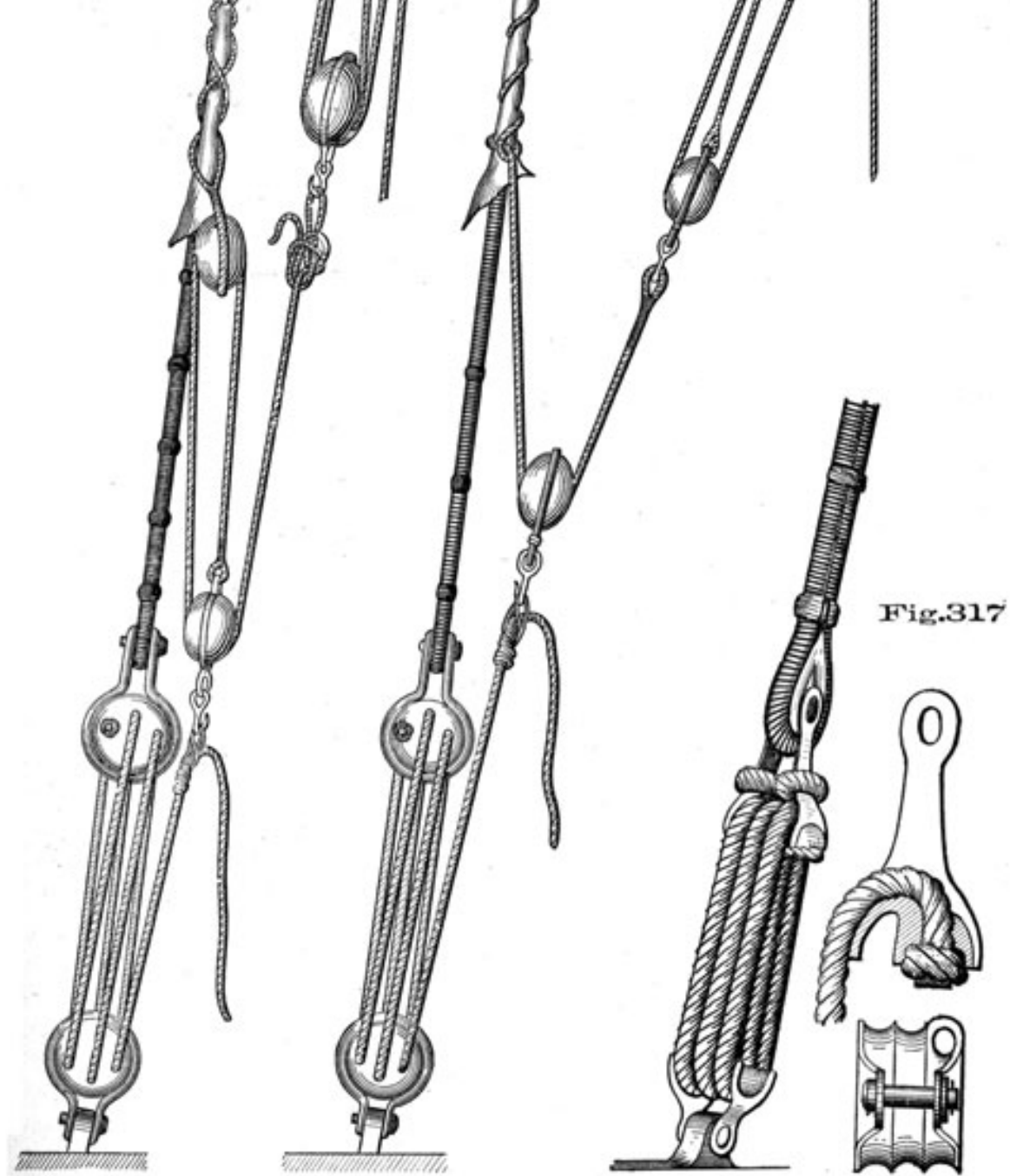
Set up all the shrouds in this manner, a pair on each side at a time, racking the laniards. The rigging is left standing in this condition as long as circumstances may permit, to give it a chance of settling in its place, when, with the same purchases used before, the stays and *then* the shrouds are set up for a full due. The final setting up should not be given, if avoidable, during very wet or cold weather.

The rigging being set up for a full due, rack the laniards, seize on the sheer poles with a cross seizing to keep the dead-eyes from slueing (on account of the tendency to unlay in the shrouds), having a strip of tarred canvas or leather underneath to prevent chafe. Secure the ends of the laniards by hitching them around the strap of the upper dead-eye thimble above the sheer pole, as in Fig. 318, bringing the end down inside the other parts and securing it with three seizings. Remove the racking from the laniard to bring an equal strain on all parts. Finally, send down the rigging luffs.

In setting up the stays temporarily, one end of the laniard is spliced around the upper heart; take two or three turns through both hearts, set up and rack the laniard. When setting up for a full due, reeve off the remaining

Plate 55





turns, set taut. cut the rackings and set up. Rack again with stout rackings; come up the tackles and pass riding turns of the laniard, heaving each turn taut in succession. Put several good seizings on the upper turns of the laniard, the end of the laniard being stopped in between the turns out of sight. The rackings are removed and only the seizings remain.

Fig. 317 shows a proposed form of dead-eye of metal. It is similar to the modern dead-eye of the British service.

Remarks on the tension given to rigging. It is of more value to have a moderate and equal strain on each shroud, rather than a great strain upon all the shrouds.

Much of the trouble experienced in former days with hemp lower rigging, by reason of stretching, is obviated by our present use of wire rope. But in placing the eyes of the shrouds over the mast-head, the permanent position of the eye may be lost sight of in the endeavor to complete the operation in as short a time as possible. The consequence is that the eyes of the rigging keep shifting their position on the mast-head for many months afterwards, producing slack rigging. It was suggested, after getting up the first pair of shrouds, to set up each two pairs separately at the time they are placed over, but this is seldom done. On the other hand, the beating down of the eye upon the mast-head should be carefully attended to, to insure a permanent and solid bearing.

With regard to the stays, particularly when the after-parts of the collars are not rested on supporting chocks, any settling of the eyes of the rigging causes the stay to settle also, but the slack shroud is much more likely to receive attention than the stay. The final result is a buckling of the mast at the partners, or else an attempt is made to overcome the increased rake by setting up the *topmast* stay, since the rake will be more apparent at the height of the topmast-head than at the lower mast-head. The consequence of hauling forward the head of the topmast, with a comparatively slack lower stay, is to strain the head of the lower mast, owing to the leverage of the heel of the topmast and the play in the lower cap. Some officers will recollect at least one sloop-of-war in which the lower masthead was sprung in this way. The conclusion is, that no setting up even of the two after shrouds should be undertaken without an examination of the lower stay, which will probably be found to require a pull even more than the rigging.

A serious evil arises from setting up rigging too taut, which is particularly noticeable in small vessels.

Let the shrouds of a schooner be pulled up as taut as harpstrings, then the liability is that when she goes to sea she will lose her masts; for when she rolls, the shrouds, which we will further suppose to be half worn, and with

little *give*, keep the mast-head to windward, while the tendency of the rest of the spar is to buckle to leeward, and this is particularly the case when reefed down.

To Rattle Down. Draw a line parallel to that of the vessel's sheer across the shroud-legs on both sides through the points where it is intended to seize on the lower ratlines, so that the latter may correspond with the line of the sheer-poles. If these marks are continued up to the trestle-trees at the proper distance (fourteen inches) apart, the work of rattling down can be carried on in several parts of the rigging at once, without referring constantly to the measuring stick.

Hook or shackle the futtock-shrouds* to the plates in the top and to the futtock band, and set them up, observing to have the points of the hooks *inboard*, so that bights of rope from aloft shall not catch over them. Girt or swifter the shrouds in by securing a piece of ratline stuff to the forward shroud, take it aft and around the next shroud and haul as taut as possible, drawing the two shrouds together. Repeat the operation with the next shroud, and so on to the after shroud, girting all in together, nippering each turn with a hitch. Place three or four swiftering lines in the rigging at equal distances apart. Lash oars or spars athwart the rigging, about four feet apart, for the men to stand on while at work.

The ratlines, Fig. 319, are usually of eighteen-thread stuff, fitted with a small spliced eye, thrust once and a half. This eye is seized on to the first shroud with marline, Figs. 320-321, or with a rope-yarn, twisted up and rubbed smooth, placing each ratline fourteen inches from the preceding one. A clove hitch is then formed *outside* around the next leg, put on so that the crossing of the hitch will lie with the lay of the rope, and the ratline hove taut, with a marline-spike. In this manner it is made to reach the last shroud, and then seized on as at the commencement; every fifth or *sheer* ratline being extended to the swifter and after shrouds, which, with these exceptions, are omitted when there is any great spread between the swifter and shroud next abaft, or between the after shroud and the one next forward of it.

The eye-seizing of the ratline must be passed so that the eye will lie in a horizontal plane, and with the strand first tucked uppermost (if the other part of the splice were *uppermost* it would form a pocket for water). Having spliced in the marline, pass it around the shroud through the eye of the ratline, back around the shroud, and so on as in Figs.

* At sea there is generally an ugly chafe between the lower and the futtock shrouds, to prevent which good iron scotchmen should be seized to the former. The practice has been to hook the upper ends of futtock shrouds to the straps of the lower dead-eyes of the topmast rigging, the strap having an eye in its

lower end which passes through a futtock hole in the edge of the top.

Plate 56

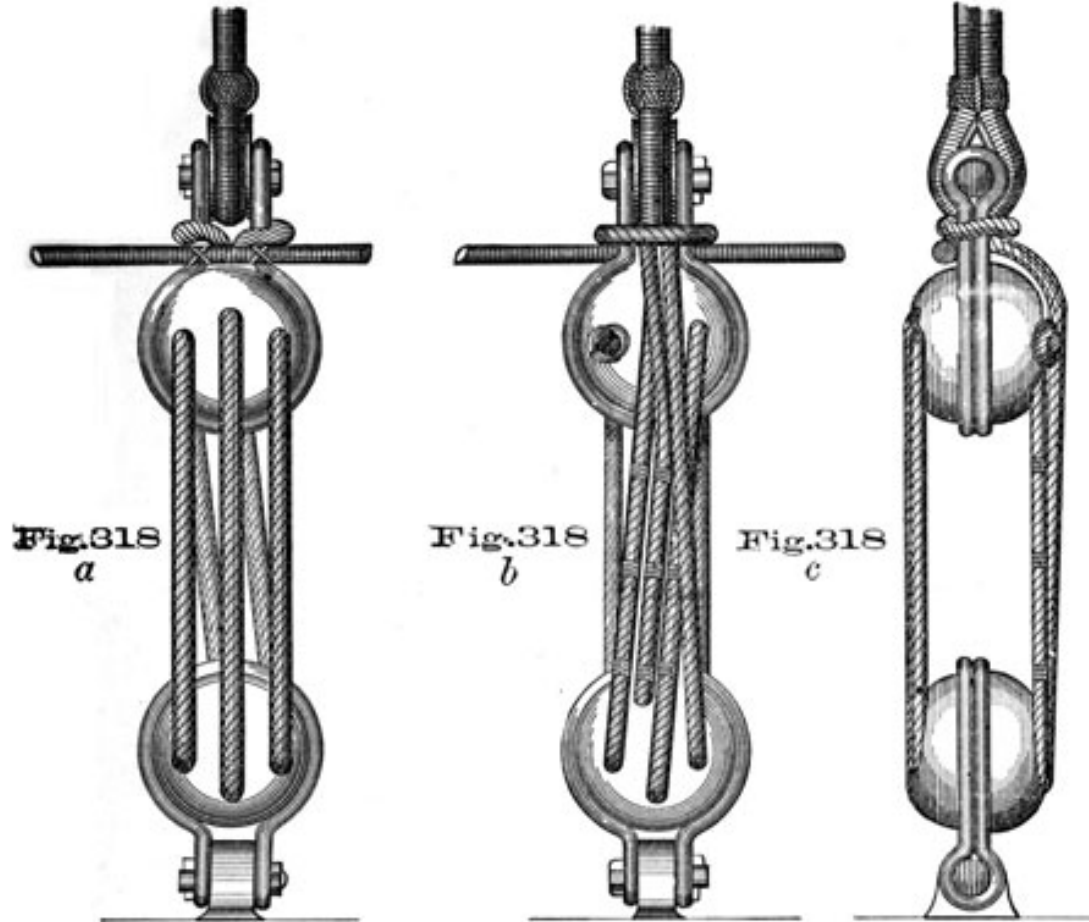
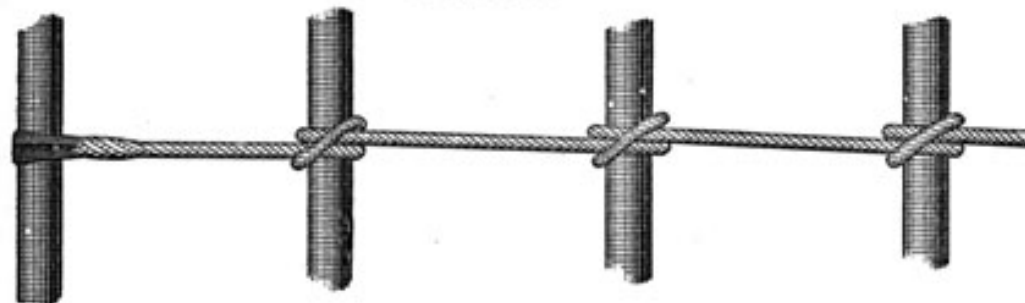


Fig. 319



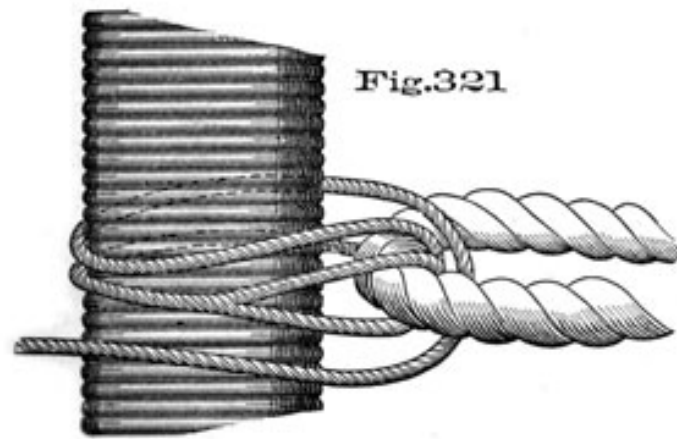
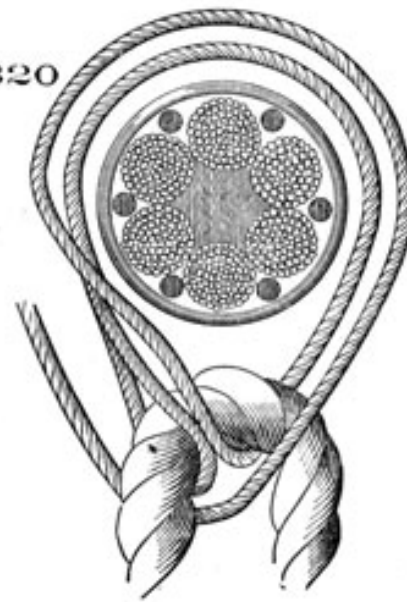


Fig.321

Fig.320



320 and 321. In cutting a ratline, say starboard side, the stuff being thoroughfooted and stretched, take one end of the coil and carry it into the rigging at the height for the ratline. Hitch it to the after shroud, keeping end enough to reach to the forward one, clove-hitching loosely around each shroud from aft forward. If you have not end enough, render more through the loose hitches. When the forward shroud or swifter is reached, form the eye in the end of the ratline and seize it on, then work back toward the after shroud, tautening the clove-hitches. When the after-shroud is reached, you can mark the exact place for the after-eye, and cut the ratline at the proper place without waste. If in the port rigging, proceed in the same way, except that the temporary hitches are put on from forward aft, as riggers generally work from *right to left* when seizing on and hitching the ratline for a full due.

If the eye has been badly measured, and the ratline is just too long to be seized on, but not long enough to allow for turning in a new eye, heave turns in it with the lay of the stuff until shortened up, or if it is too short, a few turns may similarly be hove out. This is called an *Irish splice*.

Now come up the girts employed in swiftering in the shrouds, which tautens the rigging. After which, square any shroud ends which may have required turning in afresh, capping the ends. Send down the spars and blacken down.

In sparring down rigging the forward ends should be square with each other, the spare ends aft. In rigging of nine shrouds one man should clap on four ratlines in an hour.

The lower ratlines as far up as the ends of the shrouds, are now made of rod iron, to prevent getting out of shape when the rigging is manned previously to laying aloft.

The description of rattling down is given here as in its natural order under the head of lower rigging; but instead of rattling down at this stage of the work, riggers usually fit a few temporary ratlines for their own use in getting up and down from aloft, and postpone fitting the regular ratlines until after all the rigging, masts and yards are in place.

Topmasts. We suppose the ship to be in the stream, to show, while rigging, the methods adopted for getting the various spars on board.

Tow the topmast alongside with the *head* forward,* and parbuckle it on board. Then secure a large bull's-eye to the hounds on each side, in the same plane with the lower sheave hole; hitch the end of a hawser at the lower mast-

* It is recommended in all cases of getting spars on board while in the stream (where there is a *tide-way*), to tow them alongside in the reverse manner -a topmast, for example, with the *heel* forward, &c.; then by letting the foremost end be swept aft, by the current, during the operation of swaying it on board, there will be no necessity for a hauling-guy to rouse the heel forward *against* the tide.

head, above the eyes of, the rigging, leading through the hole in the trestle-trees, and reeve the other end through one of the bull's-eyes on the topmast and the sheave-Hole; thence up through the opposite bull's-eye, and a block lashed at the mast-head, through the lubber's-hole, as in Fig. 322, Plate 57, leading it to the deck, and clapping on a pendant-tackle, or take the hawser to the capstan. With this purchase, sway the mast up and down the lowermast.* Should the topmast prove too long, the head must be swayed up outside the top rim; then open the deck-scuttle, and lower the mast, until clear of the top rim; sway it up, and point it through the trestle-trees and round-hole of lower cap. The latter is sent up "before all," with the girtlines, immediately after rigging the lowermast, by bending them on through the round-hole, and stopping them along to the after-part, Fig. 323, observing to keep the bolts *uppermost*, so that they do not come in contact with the top rim, &c., in the cap's passage aloft. When in the top, place it right side up over the square hole in the trestle-trees fair for pointing the topmast.

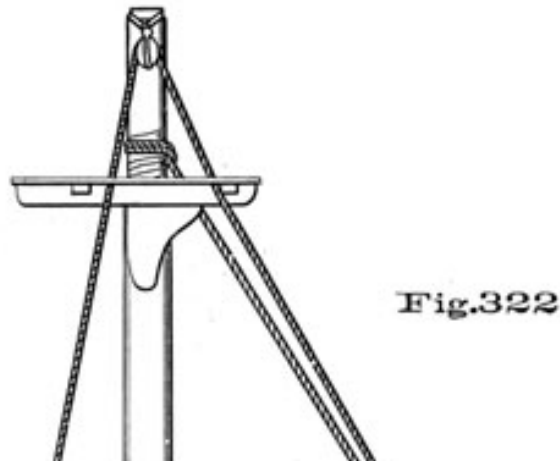
Now pass a stout strap through the fid-hole of the topmast, to which hook both the pendant-tackles; take off the bull's-eyes at the hounds and mast-head, unreeve the hawser, and prepare for shipping the CAP, which is done as follows:

To Ship the Lower Cap, Fig. 324. The topmast being pointed through the round hole of the cap, slue the cap as nearly fore and aft as the doublings of the mast will admit, with the square hole aft. Pass a secure lashing through the cap eye-bolts and over the topmast-head, and give the lashing as much drift as possible, for which purpose the head of the topmast should be several feet above the upper part of the cap. Now sway up on the pendant tackles until clear of the tenon of the lower mast, then slue the cap around, as it hangs in the lashing, until its square hole is fair with the tenon. If the lashing has not been given drift enough to permit of slueing the cap fair, the topmast itself must be slued by means of a long heaver thrust in the fid-hole and worked by guys from its ends. This ought not to be necessary. Send up the capshore (with a laniard attached, to secure it aloft) and lower away, beating down the cap into place, and tacking over a piece of sheet-lead as a protection from the weather.

To send up the Topmast Cross-Trees. Fig. 325, Plate 58. Cast off the lashings and sway the topmast-head a few feet above the cap. Lash a couple of stout burton-blocks to the tenon, send the falls down abaft for the cross-trees (placed on deck *well* abaft the mast). Secure the lower blocks to the after ends of the trestle-

* Supposing it to be the foremast.

Plate 57



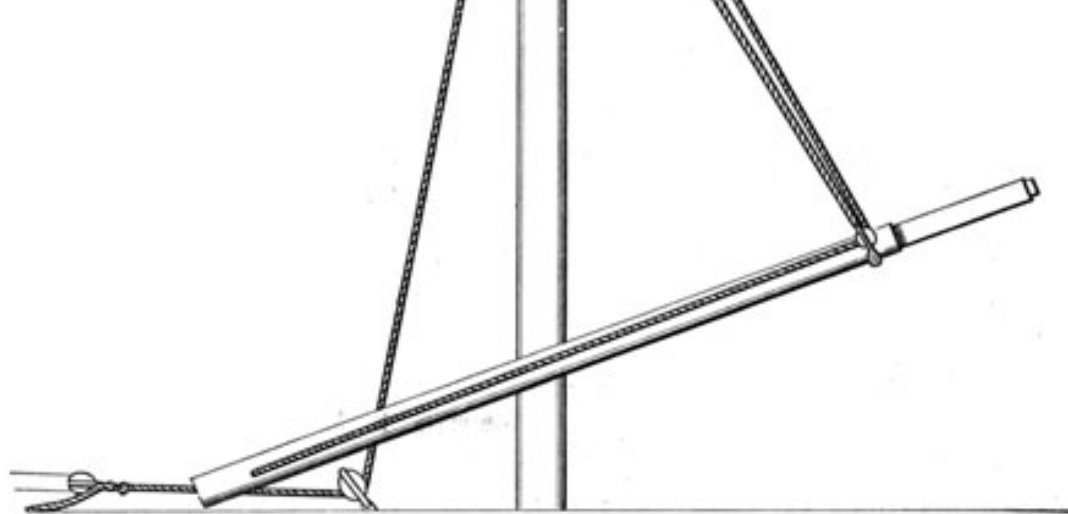


Fig.323

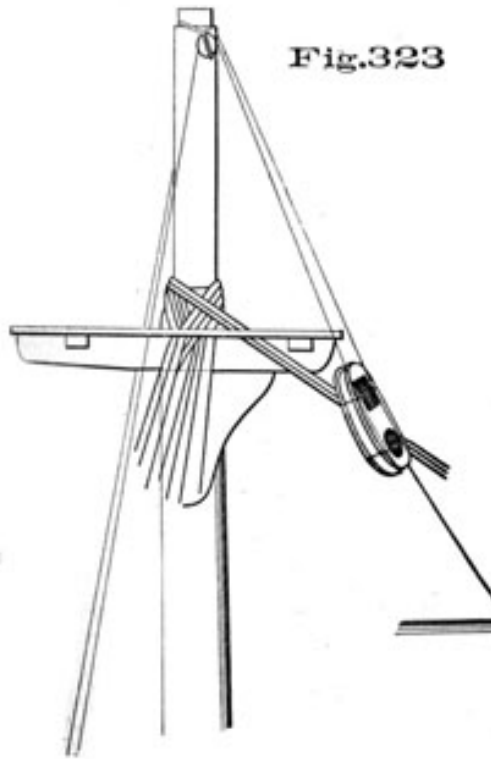
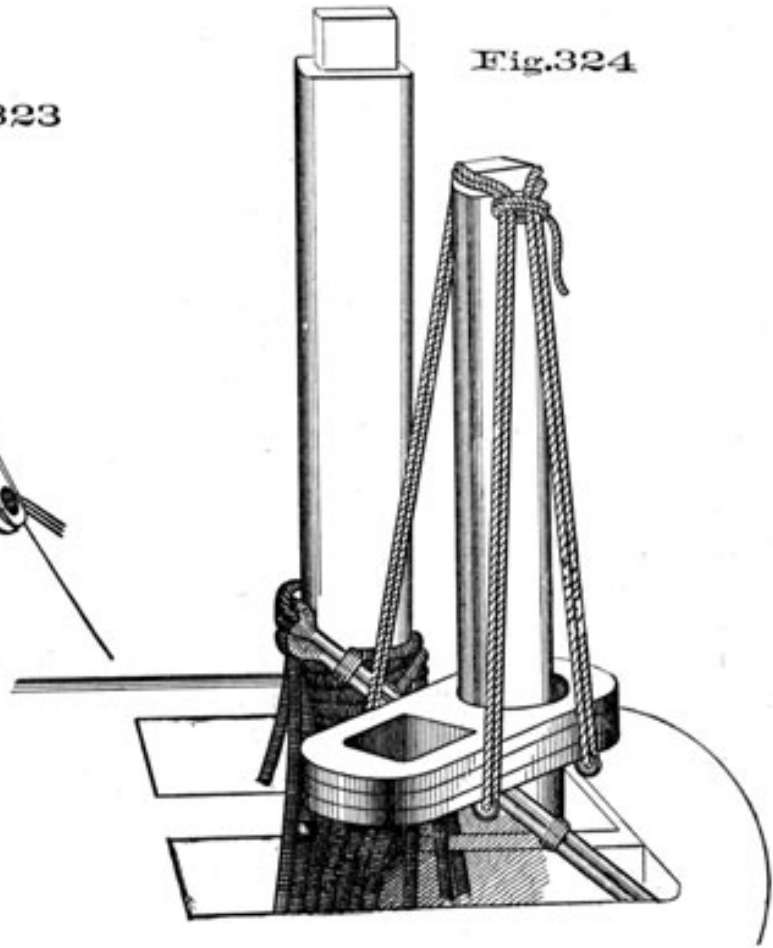
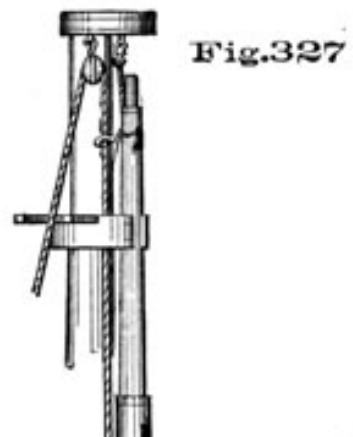
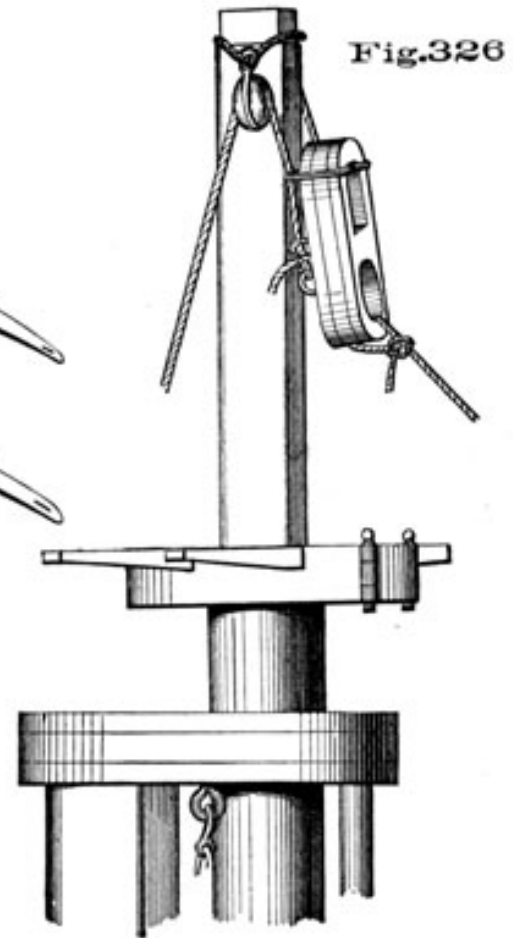
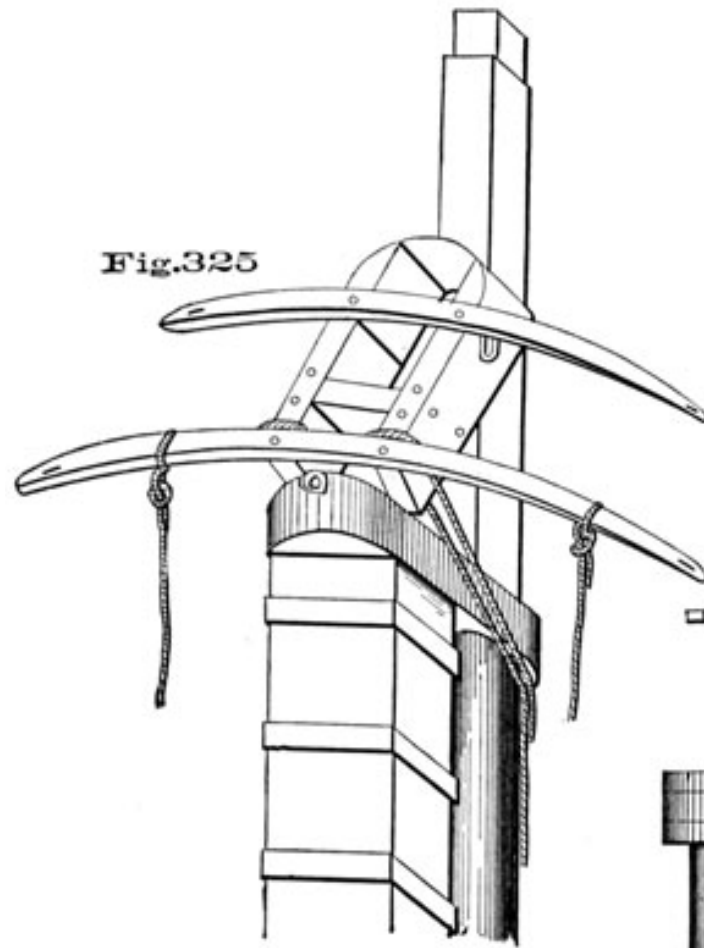
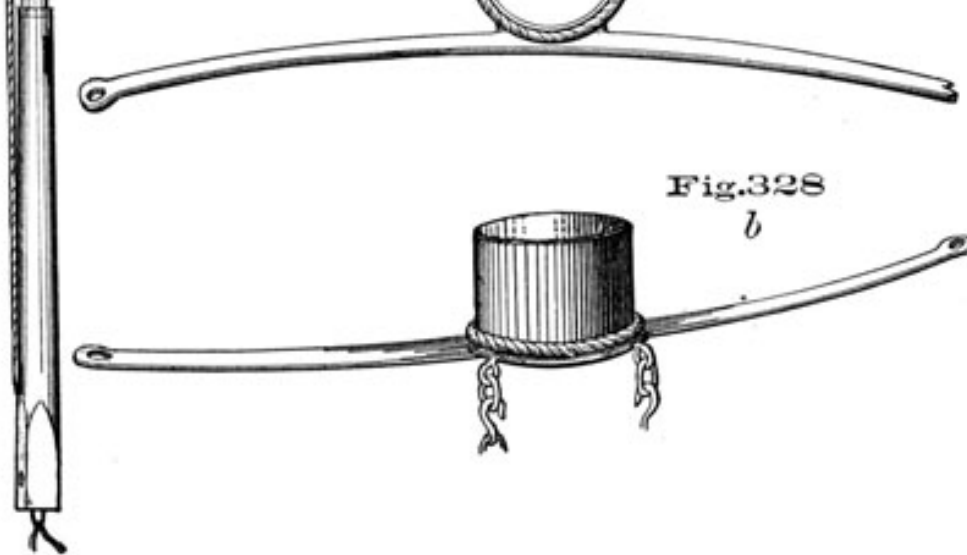


Fig.324







trees on the *upper* side, and stop the *standing* parts along the forward ends, in the same manner as that resorted to in sending up the lower trestle-trees; having a guy from the mainmast-head (if the fore-topmast cross-trees), to keep them clear of the top in going aloft. Sway up on the burtons, bear off, cut the stops as necessary, and land them on the lower cap, where they should be securely lashed, having the forward part inclined upward, with the chock resting against the topmast. Cast off the burtons, remove the blocks from the tenon or-if girtlines are used to get the cross-trees aloft (as is sometimes done)-shift them at once to the after-horns, ready for the rigging; lower away on the pendant-tackles, until the cross-trees come fair over the mast-head, cutting them forward, or aft, as may be necessary.

To Rig Topmast. Now sway up on the pendant-tackles, and lodge the cross-trees on the hounds of the topmast, prying up the after-end, and beating them down in their places. Hook the top-blocks in the lower cap and reeve the top-pendants, by passing each pointed end through its respective block, and sheave in the heel of the topmast, and clinching it to the eye-bolts, then hook the top-tackles to straps on the other ends, and remove the fid-strap and pendant-tackles used in pointing the topmast. Send up and place the composition funnel (square) over the topmast, its lower edge resting on the trestle-trees and fitted with flanges to receive the bolsters, which are well protected with tarred parcelling. The gin-bar, if not sent up with the cross-trees must now be placed. It consists of a stout flat bar of iron placed across the top-mast and trestle-trees between the doublings of the mast, with links for the gin-blocks.

Send up next the burton pendants which shackle to bolts in the under side of the trestle-trees. Using girtlines from each after-horn of the cross-trees, and an eye girtline from the topmast tenon, proceed to get

up the shrouds and stays in the following order, after the manner employed in getting up lower rigging, except that *two* pair, starboard and port shrouds, come up together.

First. Starboard and port shrouds, in pairs.

Second. Backstays.

Third. Fore-and-aft-stays and jib-stay, in one, the latter uppermost.

The ends of these shrouds and stays are allowed to hang down outside the top in their proper directions, on each side, forward, or aft as the case may be.

To Send up the Topmast Cap, Fig. 326. Shift the girtlines from the cross-trees to the topmast-head, lashing the blocks below the tenon; send down the ends for the topmast-cap, which is sent up from forward with the after-part uppermost, the ends of the girtlines hitched to

the forward eye-bolts, and stopped down toward the after-part of the cap, similar to the mode of sending up lower trestle-trees. It is slipped into place on the tenon of the topmast-head by the men aloft, cutting the stops, as necessary.

The topmast cap may be shipped, with the assistance of the topgallant-mast, in a similar way to that followed in placing the lower cap, but the method given is much the easiest.

If the topmast is fidded, and topgallant-mast is not aloft, riggers frequently handle the topmast-cap as follows, particularly in stripping ship. A suitable small spar (studding-sail yard) is pointed through the round hole of the cap and the cap is securely lashed to the spar. The spar is controlled by two whips whose blocks are lashed to the masthead below the cap. The whip ends secure to the spar, one near its heel and the other a little below the cap and *not* in the same vertical plane as the first whip. By means of these whips the spar (and cap) can be lifted and slued as required.

Reeve the topmast-stays through the bees in the bowsprit, turn them around the thimbles of their hearts and clap luffs on them to steady the mast when fidding; reeve off also the laniards of the backstays, and tend the stays and backstays while the mast is being swayed aloft by the top-tackles and fidded. The topmast being fidded, reeve off the laniards of the topmast rigging and prepare to set up.

To Set up Topmast Rigging. Hook the lower blocks of a rigging luff to a strap on the laniard; tail the

upper block to the shroud six or eight feet above the upper dead-eye, hook the top burton into the end of the luff. Having given the mast the proper stay, by means of the luffs on the topmast stays and backstays, set up the shrouds in a manner similar to that adopted in the case of lower rigging. Stays, backstays, and shrouds should all be first set up temporarily, and later for a full due, in the order named.

For light rigging a runner may be used instead of a rigging luff, in setting up, Fig. 316, the top-burton being hooked in the thimble of the runner. Avoid the use of catspaws in the laniards, unless the ends are long enough to admit of cutting off afterwards. The rigging being set up, lash on the sheer poles, secure the ends of the laniards and come up the rackings on them. Lash on the futtock staffs below the eyes of the topmast rigging and *inside* of the shrouds. These are of rod iron, well served and leathered in order not to chafe the topgallant rigging which passes over them in its course to the top. Seize the forward catharpin legs on each side to the forward shroud, and the after-ones abaft the mast to the after-shroud on the opposite side. The two catharpins thus cross abaft the mast

and are seized together in the cross. General view of eyes of topmast rigging, Fig. 331.

When ready to rattle down, girt in, and proceed precisely as in rattling down lower rigging, but without omitting ratlines at any shroud.

Sometimes, after the lower and topmasts are rigged, a tarpaulin coat, fitting snugly, is placed over the eyes of the rigging, as a protection from weather. This answers very well, and if painted, does not detract from the neat appearance of the mast-head.

Jib-Boom. Being in the stream, bring the boom alongside with the head forward, and reeve a spare piece of rope (studding-sail halliards if at hand), through the sheave-holes in each end, a sufficient number of times, and make it fast. Overhaul down the main pendant-tackle, and hook it into a cuckold's neck formed in the bight of the span, having the boom to hang slightly *heel* heavy. Sway it up, bearing it clear of the ship's side - ease it inboard, and land it in the gangway; unreeve the span, and carry the boom forward, pointing it through the bowsprit-cap, and reeve the heel-rope, which is done as follows: Pass one end through a single block, hooked to an eye-bolt on one side of the bowsprit-cap; thence through the sheave in the heel, and clinch it to the other bolt, on the opposite side of the cap. Man the heel-rope, and rig the boom out, until the shoulders are just forward of the bowsprit end.* Put on the band if not already on. This band is fitted with eyes on each side and underneath for the jib-guys and martingale.

The foot-ropes are fitted with eyes in their outer ends which seize to the jib-guys close to the shackle on

the band. The foot-ropes are then stopped out to the guys, that on the starboard side for a sufficient distance to keep it clear of the flying jib-boom. Turks-heads are worked on the foot-ropes at equal distances, to keep the men from slipping on account of the inclination, or *steeve*, of the boom. The inner ends of the foot-ropes are formed into eyes which are seized to the upper bolts in the bowsprit cap after the jib-boom has been rigged out. Thus fitted, the foot-ropes should be long enough to allow the men who go on the boom to stand with the lower parts of their breasts against it. Reeve the jibstay through the inner sheave-hole of the boom end. Sway the dolphin-striker to its place by means of a tackle from the bowsprit cap and a whip from the jib-boom end and hook it to its eye-bolt; shackle to it the lower end of the jib-martingale and the back-ropes. Fig. 333 shows jib-boom end, and Plate 51 general view of head-booms with detail of whisker and dolphin striker. Place the jib-guys

* In handling a large boom, it will be necessary to have a tackle from the fore-stay hooked to a strap on the head of the boom, to raise and guide it through the cap.

124

over the whisker ends (see *Whiskers*) ship the wythe for the flying jib-boom; man the heel-rope and rig out, placing the heel in the saddle and clamping it. Unreeve the heel-rope, set up the jib-guys, when ready, and the jib-martingale, the latter being set up by pulling on the back-ropes. Lastly, set up the jib-stay.

The jib-netting is made of ratline stuff, with 6-inch meshes, and laces to the guys and whiskers.

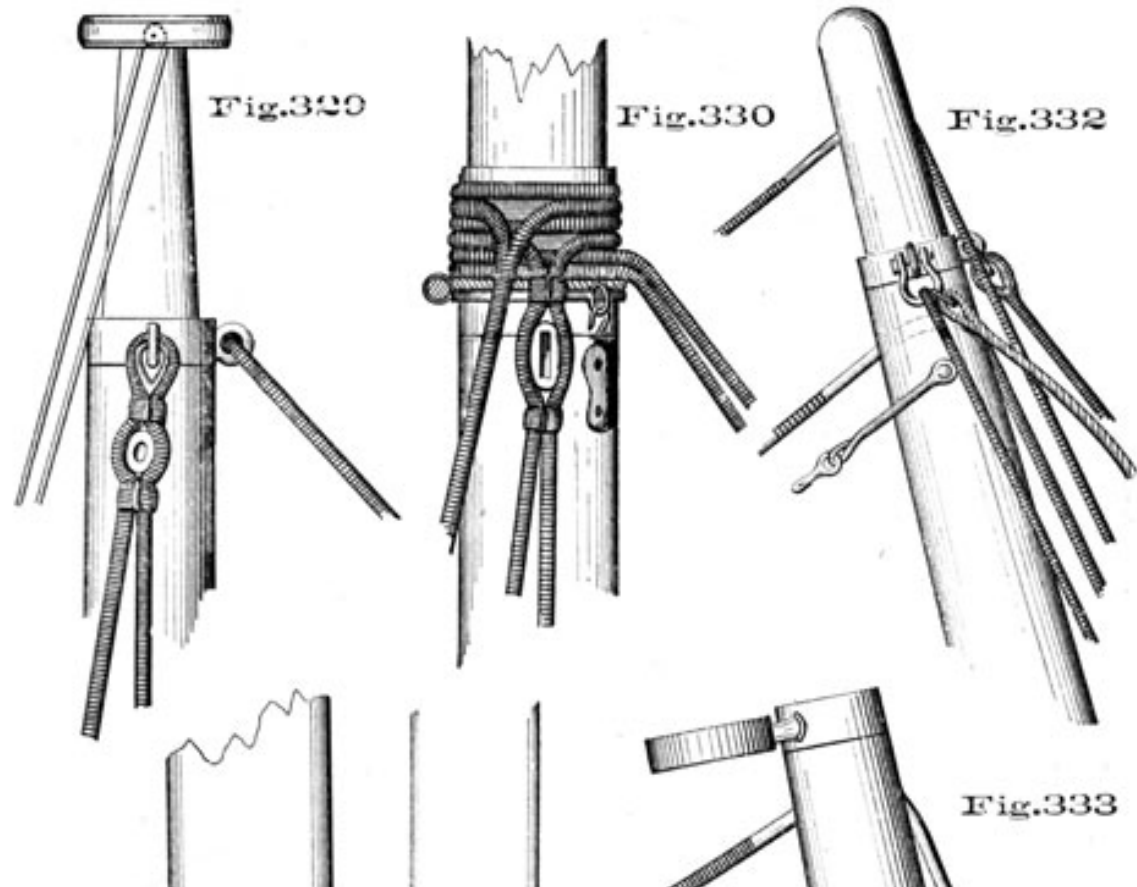
Whiskers are swayed on board with a tackle from the forward swifter. A whisker is got into place ready for rigging by means of a jigger from the fore-topmast stay, hooked to a strap about one-third the length of the whisker from its outer end, and another jigger from the bowsprit cap to its inner end. When far enough out the whisker is hooked to a bolt in the bees. When hooked, put on the jib guy, which is fitted with a neat eye to o over the whisker end, and then the whisker jumper. This jumper goes over the whisker with an eye, and sets up to the cutwater, or it may lead through a clump block on the cutwater to the ship's head where it is set up.

When the flying-jib-boom has been placed and rigged, the flying-jib-guys are rove through a hole in the whisker, or through a thimble strapped (with wire rope) to the whisker, outside of all, thimble on top. Jib and flying-jib guys set up to the bows, or cathead, with three scored hearts.

The whisker being rigged, slack the stay jiggers, which serve as lifts, and haul on the jib-guys to bring the whiskers athwartship. For detail of rigging on whisker, see Plate 51, Fig. 305, where standing part of forward guy is omitted to avoid confusion.

Topgallant Masts. Get the topgallant-mast on board by means of the mast rope. Hook the topgallant top-block to a bolt in the topmast cap, and reeve the mast rope first through the block, then through the thimble of a stout lizard, the tail of which is hitched in the royal sheave-hole; lastly, through the sheave in the heel, and cast an overhand knot in the end, or hitch it around the mast to its own part. When the topgallant mast is on board, and up and down forward of the lower mast, secure it there temporarily by a lashing around the head from the lower stay collar, passed clear of the mast rope; cast off the hitch in the end of the mast rope and carry the standing part aloft, hitching it to a bolt in the topmast cap, on the side opposite to where the block is hooked. Fig. 327. Set taut the mast rope, cast off the stop at the stay collar and sway the mast aloft, bending a tripping-line to a bolt in the heel to guy the mast clear on its passage up. Point the head of the royal-mast and sway it up three or four feet above the topmast cap, taking off the lizard, which is now of no further use. When the topsail yard is in its place, the *gate*, a broad iron

Plate 59



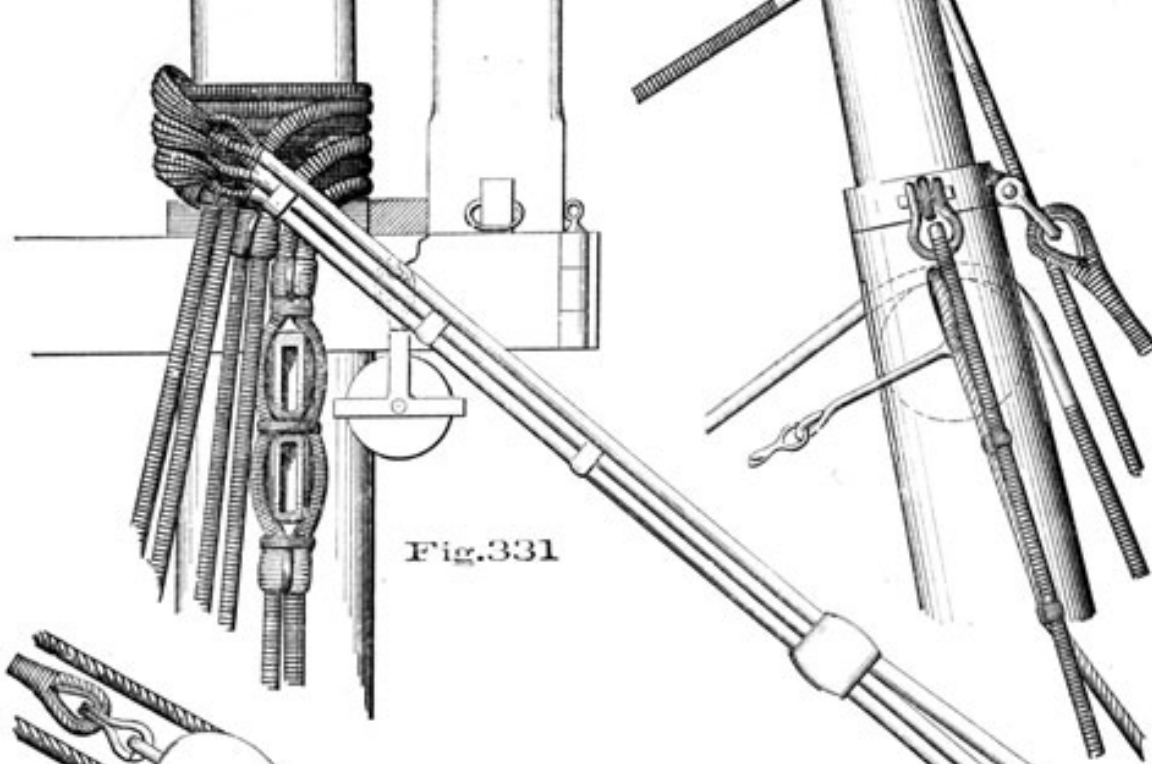


Fig.331

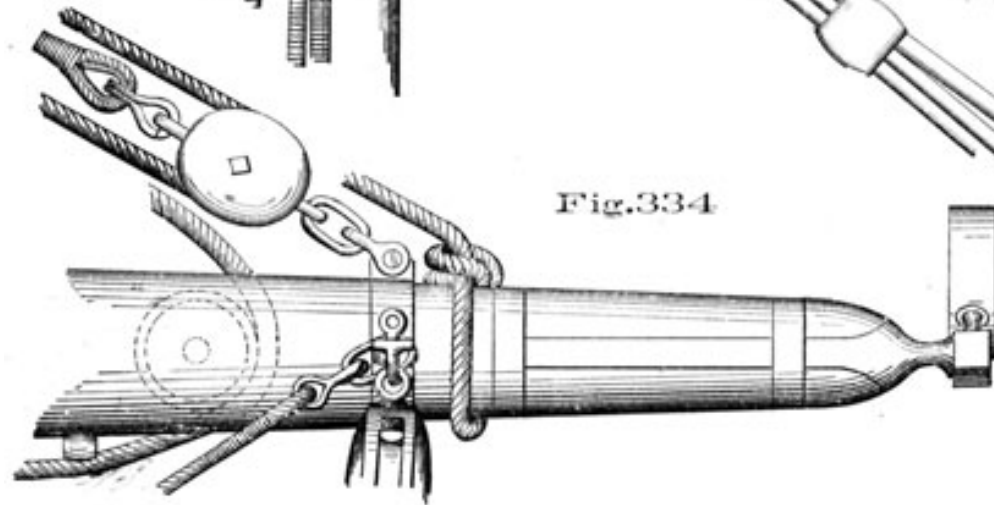


Fig.334

band across the forward part of the trestle-trees. hinged on one side, should be opened while the mast is being swayed aloft to enable it to pass up. The gate is closed as soon as the heel has cleared the topsail yard, and the swinging end secured with a pin.

Topgallant Rigging, &c. Lash a stout girt-line block to the topmast cap on each side, and send down the ends of the whips abaft all for the jack and funnel, fitted in one, Fig. 328. The rim of the funnel is rounded off to prevent chafe. A grommet fitted on the funnel acts as a bolster for the rigging. Land the funnel on the topmast cap, lash it temporarily, lower on the mast rope till the royal mast-head is about flush with the cap; cast off the girtline and place the funnel. Sway up again on the mast rope and point the royal mast-head well clear of the funnel. Then with the girtline from the cap, sway aloft and get over the stays and rigging in the following order:

First, Fore-topgallant stay.

Second, Flying-jib stay.

Third, Shrouds.

Fourth, Back stays.

The eyes of this rigging are made to fit the funnel exactly. Fig. 330.

A clump-block seized between the topgallant shrouds, below the eye, is for the topgallant lift. Pass the ends of the topgallant shrouds over the futtock staffs, and thence into the top, where they are to be set up with hearts. Do not clamp these shrouds into the horns of the cross-trees until swayed aloft, as it gives just so much more gear to overhaul. The mast can be steadied sufficiently, until fidded, by the fore and aft stay and back stays. Take the back stays to the channels, and reeve the fore and aft stay through its sheave in the jib-boom.

Royal Rigging. Send up by means of the girt-line at the topmast cap the royal band, with the rigging fitted upon it as described in the previous chapter. Place the band on the mast-head, Fig. 329, reeve the royal shrouds through the arms of the jack to the top, take the back stays to the channels and the fore and aft stay through its sheave in the flying-jib-boom, when the latter is ready for rigging out.

A small clump-block for the royal lift is seized in between the shroud and back stay, below the band.

Place the truck, with signal halliards rove and spindle and lightning conductor (copper wire) attached, man the mast rope and sway up the mast, overhauling well the royal shrouds, &c. When the mast is fidded and the flying-jib-boom is rigged out and clamped (see below), set up the stays, back stays and shrouds with jiggers, not forgetting to clamp the topgallant shrouds in the horns of the cross-trees before setting

The Fore-Topgallant Stay reeves through the outer sheave in the jib-boom, the fore-royal through the hole in the flying-jib-boom, outside the sheave for the flying-jib stay.

The Jib and Flying-Jib Stay reeve through the inner sheaves or holes in their respective booms.

The Main Topgallant Stay reeves through a hole in the after-part of the fore-cap, setting up in the fore-top. During continued exercises in sending up and down topgallant-masts this stay is frequently led down to the deck, abaft the fore-mast.

The Main Royal Stay reeves now through the after chock of the fore-topmast cross-trees, so that if the foretopgallant-mast goes the main royal-mast is not in danger. In sending up topgallant-masts the main can be stayed without waiting for the fore. Sets up in the fore-top.

The Mizzen Topgallant Stay reeves over a small roller in the after-part of the main-cap. Sets up in the main-top.

The Mizzen Royal Stay leads through a sheave in the after chock of the main-topmast trestle-trees, and down into the main-top.

All these stays set up with hearts and laniards.

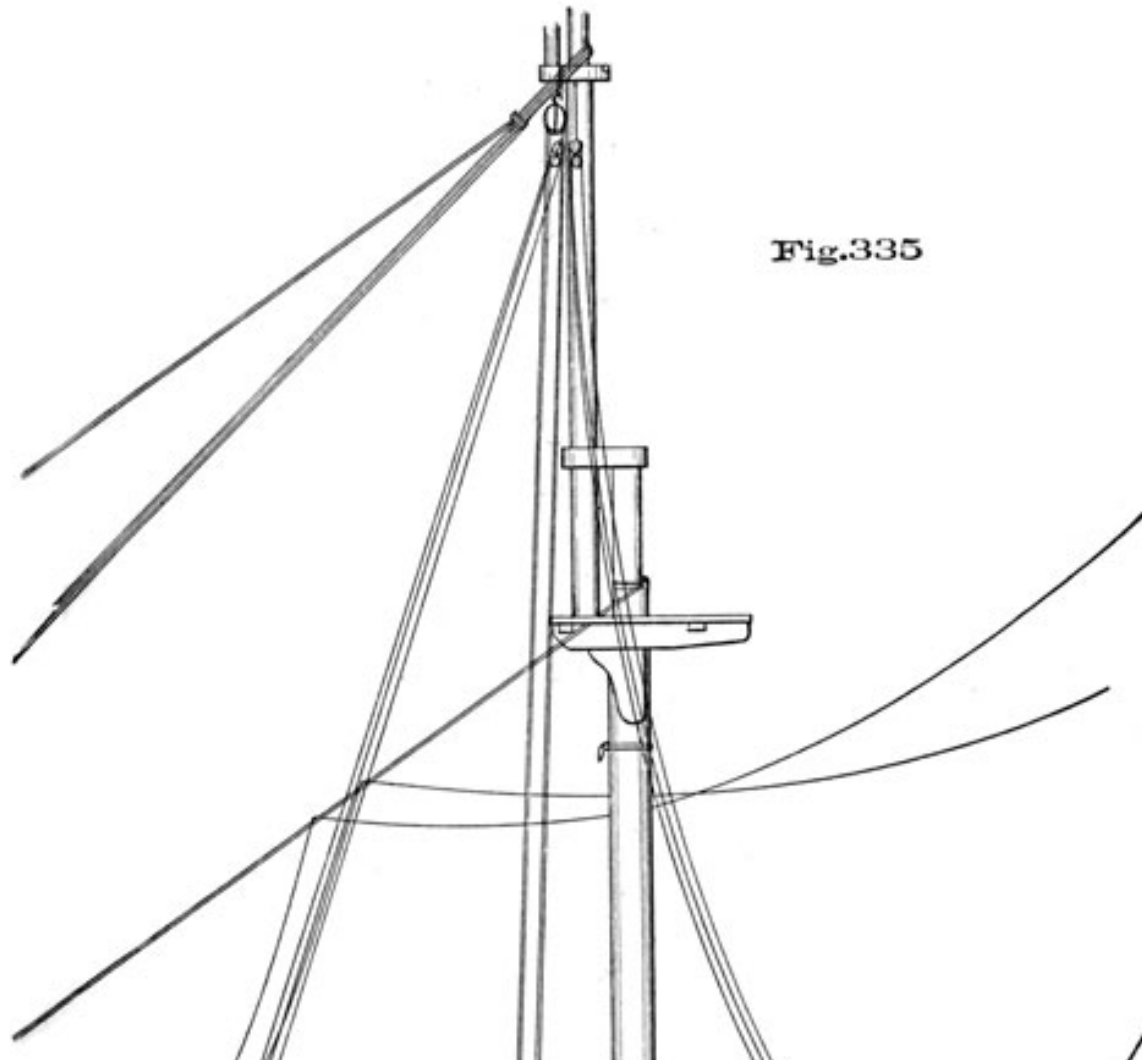
Flying-Jib-boom. Figs. 304 and 332. Sway it on board with a span, as directed for the jib-boom, and rest it on the head-rail ready for going out. Hang the heel by a slip rope from the fore-topmast stays, reeve off the heel rope through a block secured to the jib-guy, through the sheave in the heel of the boom, securing the end to the neck of the wythe. Pull out on the heel rope and point the end of the flying-jib-boom through the wythe, with the shoulders clear of the jib-boom end. Put on the head of the flying-jib-boom, the band (of iron) fitted with eyes for the flying-jib guys on each side, and one eye underneath for the flying martingale. Reeve the end of the flying martingale through a sheave in the end of the dolphin striker, and the guys through the holes (or thimbles) at the whisker-boom ends. Reeve also the flying-jib and fore-royal stays in their respective sheaves, and under the cleats on the dolphin striker. Seize the foot ropes to the shackles for the flying-jib guys, stopping them out a short distance to the guys, and seize the inner ends (when the boom is rigged out) to the jib guys. Rig out, taking off the slip rope from the fore-

topmast stays, clamp the heel to the side of the cap, unreeve the heel rope. Set up the flying-jib martingale, then the fore and aft stays, lastly the royal back stays, shrouds, and flying-jib guys.

Observe that in staying all masts the stay is usually set up first and then the back-stays, if any, and lastly, the shrouds.

Topsail Yards. Having towed the yard off to the ship, say on the port side with the starboard yard-arm

Plate 60



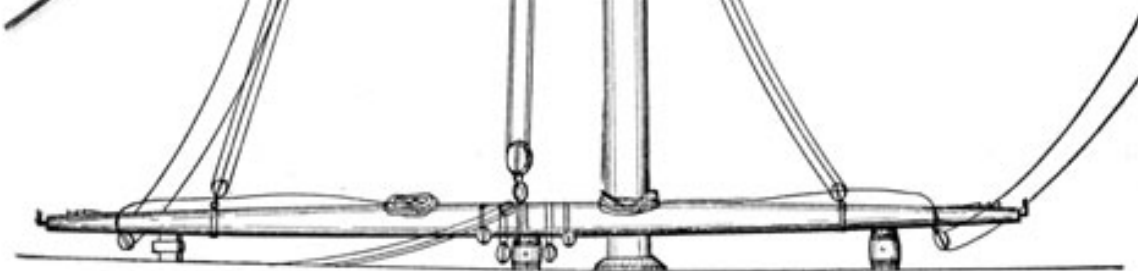
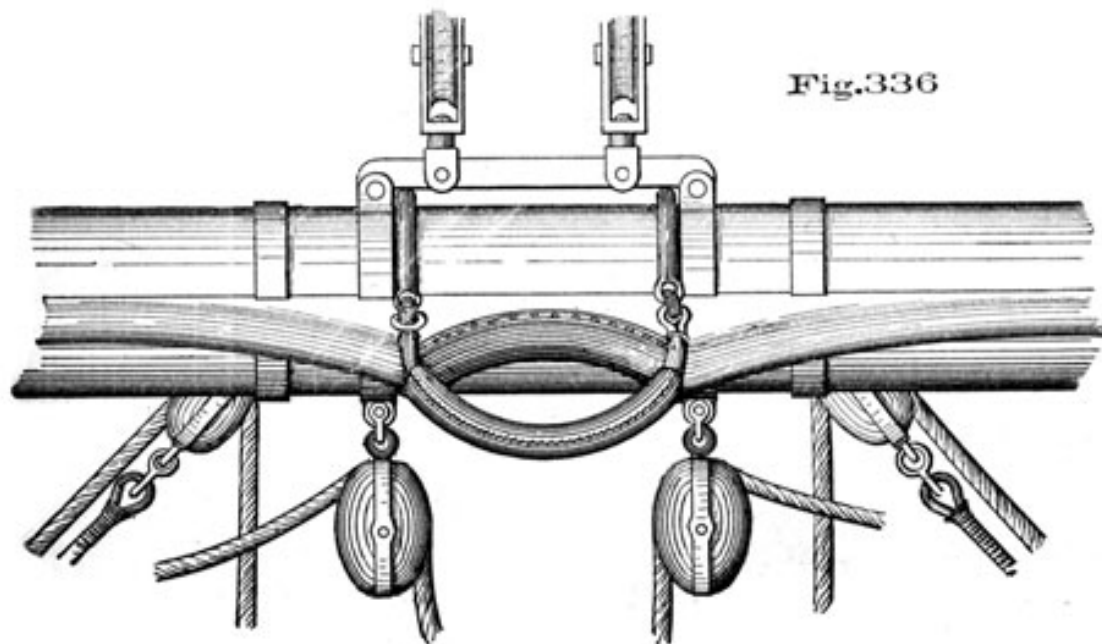


Fig.336



forward, lash a large single block at the topmast-head, into a strap sufficiently long to permit it to hang clear of the trestle-trees. Through this reeve a hawser down (outside of all), and bend it on to the slings of the yard, either stopping it to the forward (in this case starboard) quarter, with stout lashings, or use a lizard, and secure the ship's side from chafe by fenders and skids. Hook the port pendant tackle also to a strap on the after-quarter, and man it and the hawser (taken to the capstan), swaying the yard on board, which must be kept from canting aft against the mast by means of a purchase or guy leading from forward. Ease the lizard (or stops) as necessary, sway on the pendant tackle until clear of the ship's side, and lower away, landing the yard as you had it alongside (*viz.*, with the starboard yard-arm forward), in the port gangway, on chocks, which should also be placed underneath the *inner* quarters, to keep the yard from becoming bowed in the slings through its own weight. Now cast off the hawser and tackle and prepare for rigging.

It is customary to place the fore-topsail-yard in the port gangway for rigging, and the main-topsail-yard in the starboard.

For detail of slings see Fig. 336, of yard-arm, 339.

Quarter Blocks are iron-strapped, with friction-rollers, shackled to bands on the quarters of the yard, underneath. In case of accident compelling the use of a rope strap, it should be single with lashing eyes. There should be separate bands and blocks for the clewlines, as shown in Fig. 336. If not, the quarter block is either double for the topgallant sheet and topsail clewline, or treble, if the topsail reef tackle leads under the yard.

Burton Straps. Iron bands a few feet inside of the yard-arms, with an eye in the upper part to which the top burton may be hooked.

Bolt for Bead-Earing, Fig. 372, Plate 71. A bolt on the forward side of the yard, just inside the shoulder and well up on the yard; or it may be an eye in the shoulder band.

Backer for Head-Earing, Fig. 372, Plate 71, is a broad piece of sennit nailed around the yard, inside and clear of the topgallant sheet, and fitted with a thimble in its hanging end. The head of the topsail is hauled *out* by the turns of the head-earring taken through the bolt and held *up* on the yard by the turns taken through the backer, as will be described more fully under BENDING SAILS. For backer, see Fig. 372.

Jack Stays for bending are of rod iron, those for reefing, on the topsail yard, may be of wire rope, rove through staples abaft the bending jack-stay on the upper part of the yard, outer ends going over the yard-arm with eyes, the inner ends set up to each other in the slings by

means of small eye-lashings. A rod iron jack-stay often replaces it. Fig. 372.

Foot Rope. These are of hemp, fitted with an eye going over the yard-arm. They are wormed and the splice served. The neck of the splice lies a little abaft the top of the yard, so as to be clear of the topgallant sheets. Foot-ropes are fitted rove through the stirrups, and the ends taken abaft the mast (*when the yard is crossed*), and secured to the opposite quarters on top, by means of an eye-lashing passed over the yard, round on the forward side, underneath, up, and back through the eye again, a sufficient number of times; after which two half hitches are taken around all parts to secure the end. This plan of fitting them is recommended, on account of the facility with which the men can get on and off the yard.

Instead of the eye the outer ends of foot-ropes may be fitted with hooks connecting to an eye-bolt on the after-side of the shoulder-band, or else as described under FLEMISH HORSES. Inner ends of foot-ropes omitted in Fig. 336 to avoid confusion.

Stirrups are fitted with an eye in the lower end (*no thimble*), through which the foot-rope reeves and to which it is seized. The upper ends, fitted with small eyes, are seized to the jack-stay staples.

Flemish Horses. These are spliced around a thimble on the pacific iron for that purpose, and the eye in the other end secured on top of the yard to the jack-stay, the length of the yardarm inside of the sheave hole, with a rose-seizing. These are foot-ropes for the yard-arm men when reefing, &c. It would be better, as is already done on some modern ships, to do away with the flemish horses by carrying out the foot-rope to the pacific iron, fitting the necessary extra stirrups.*

Tye Blocks are iron-strapped and connected by a bolt to a band around the slings of the yard; or, in case of two tyes, the tye-blocks shackle to bands fitted at the slings, at a distance apart equal to the diameter of the topmast. The bands are joined by a span, which is used for the purchase to hook in when sending the yard up and down. In case of an accident to the straps of tye-blocks, requiring them to be fitted with rope-straps, it is well to remember that *two single straps* are needed to make the block stand fair on the yard.

Parrel. A parrel fitted of wire rope is commonly used. This consists of a long and a short leg, leathered singly, marled together, and again leathered in the wake of

* The flemish horse was introduced when lifts and brace-block straps went over the yard-arm with eyes,

and it enabled these to be removed or put on without coming up anything but the inboard lashing of the flemish horse. Now that all this gear is differently fitted, a separate outboard foot-rope is superfluous, and is going out of use.

the mast, Fig. 336. Eyes are spliced into the ends of the two legs, and stout quarter seizings placed on both close to the eyes of the short leg. The long leg then passes around the quarter of the yard, half the diameter of the topmast from the centre, and secures to the short one by a rose-seizing on the *upper* after side. When the yard is crossed the remaining leg is passed on the opposite side and secured in the same manner. There are additional seizings through holes in the jaws to keep the parrel in place. In time these parrels will probably be replaced by an iron cylinder, sliding up and down the topmast, to which the topsail yard is secured by a truss similar to the one on the lower yard. This cylinder, or *tub*, keeps the yard well trussed to, and its lower edge is low enough to keep the yard off the cap.

Brace Blocks. Iron-strapped, with friction-rollers, and shackle to the after-bolts in the shoulder-band, block sheave standing up and down. In case of accident to the strap or bolt, use a grommet strap around the yard, single strap around the block, the two straps connected by lock thimbles.

Lifts are four-stranded, hemp, and blacked. Hook to the shoulder-band, reeve through lower sheave of a sister block seized in between the swifter and next shroud in the topmast rigging, just below the eyes, thence to the top, where they turn up through clump blocks. Set up with jiggers.

Jewel Blocks. Single, rope or iron-strapped, hook to the pacific iron with sister hooks. Not put in place until the studding sail gear is rove off.

Tyes. Flexible wire rope. The lower end has a thimble spliced in, to which hooks the fly-block. Passing through the mast-head gin-blocks, they reeve through the tye-block on the yard from *out*, *in*, thence up through the topmast trestle-trees, and made fast around the mast-head. The heel of the topgallant-mast is scored out on purpose to admit the tye.

Small ships have a single tye only, which in this case reeves through a sheave in the topmast, in stead of a gin-block. Bell's purchase (see TOPSAIL HALLIARDS) is used in connection with such tyes.

The length of the tyes should be such that the fly-blocks will be square with the lower cap when the yard is down.

See that the yard is fitted with boom irons, reefing cleats, saddles (inboard from sheave holes) for topgallant sheets, &c., and prepare for sending it aloft.*

Hook a stout double purchase from the topmast-head to the tye-band (or a strap) in the slings of the yard, Fig. 335.

* It may be noted here that the iron work, bands, &c., described in connection with the yard fittings are all in place, as a rule, before the yard is sent on board, and are enumerated only to complete the list of the fittings. In former times nearly all of the above described fittings were of rope.

9

130

Coil the lifts on the quarters of the yard (stopping them to, the jack-stays), and reeve marrying-lines for the braces, observing to dip the starboard (or *upper*) one *over* the lower stay. Overhaul the top-burtons from aloft, and hook them to the yard-arms; as also a fore-and-aft tackle to the slings to keep the yard from chafing against the mast, as it goes up.

Man the purchase and walk away, taking through the slack of the starboard-burton, keeping control of the *port* (or lower) yard-arm, and placing a mat under it to prevent injury to the deck. As soon as the upper yard-arm is well up and clear of the lower stay, commence crossing by keeping to the slack of the fore-and-aft tackle, hauling on the lower burton and starboard brace. Reeve the lifts through the sister-blocks, and as the yard rises above the lower cap, square it; bring to and pass the parrel. Reeve the tyes, hook the fly-block with the halliards rove, and take the strain from the burtons and purchase, which may now be unhooked, and the latter sent down, together with the fore-and-aft tackle. Observe, lastly, to place a block of wood between the slings and lower cap, to keep the yard from bowing, in case the halliards should be slacked or let go; or, as sometimes practised in large ships, have a midship-lift fitted, of such a length as not to permit the yard to touch the cap.

N.B.-This routine supposes the yard to be lying in the *port* gangway, with the *starboard* yard-arm *forward*.

Lower Yards. Of the many methods suggested for getting a lower yard on board, the following may be selected as the safest and most seamanlike:

The yard is towed alongside, on the *starboard* side, with the *port* end forward. Top up the fish-boom, Fig.

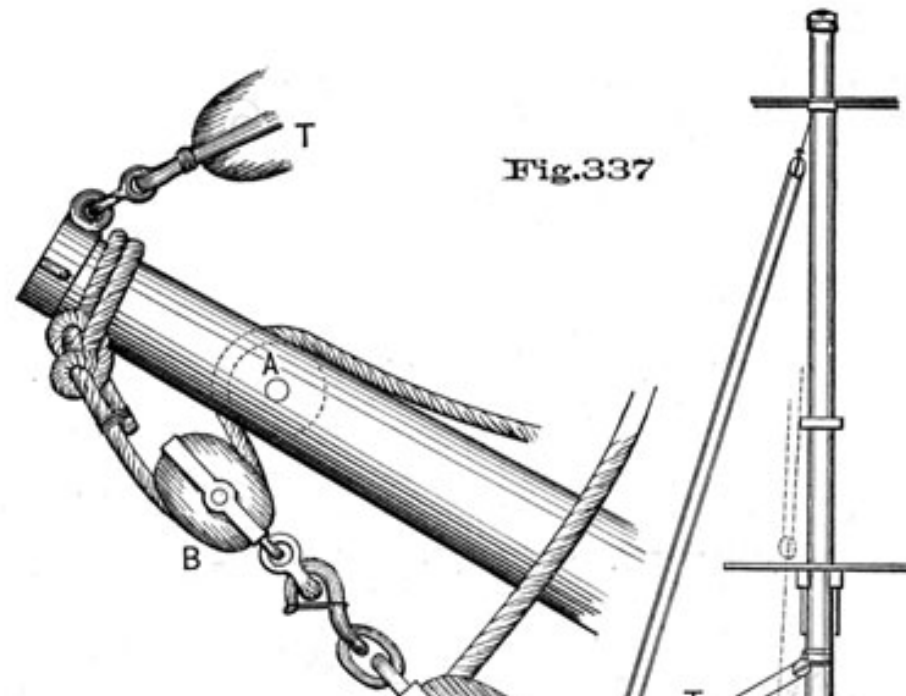
337, by its topping lift T, the upper block being hooked at the futtock band. Swing the boom around to the starboard side with the usual forward and after guys. (For description of fish-davit, see GROUND TACKLE.) Should there be no sheave in the boom, as at A, lash a block at that point. Lash together two large single blocks, as at B and C. Reeve a pendant through A and B, securing the outboard end to the head of the boom, and take a turn with the other end of the pendant at the sheet bitts.

Through the block C reeve a hawser, make fast to the bight above C the lower block of a treble purchase from the topmast-head. The other end of the hawser is secured at the slings of the yard, and stopped along the port yard-arm to the pacific iron, with rope stops.

Protect the hammock rail where the yard is to be landed by blocking up in the netting above the level of the rail.

When ready, tow the after (starboard) yard-arm out from the ship, keep it end on to the vessel with a guy from forward. Walk away with the treble purchase, and as the

Plate 61



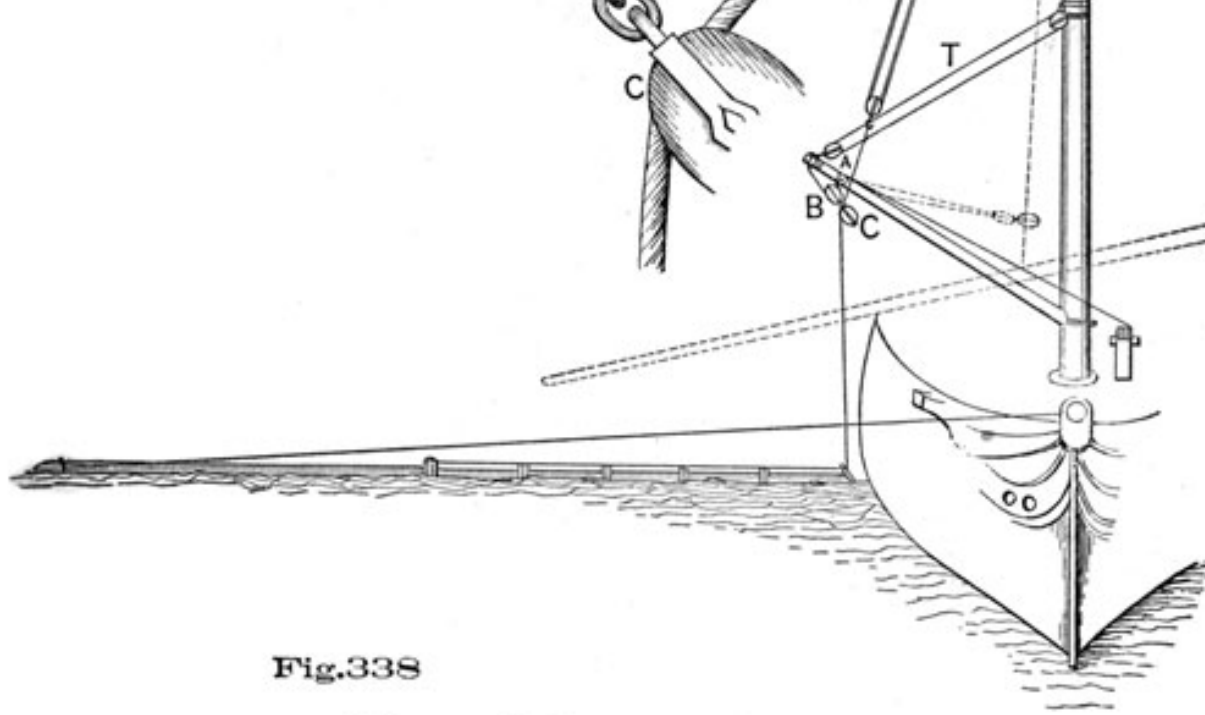
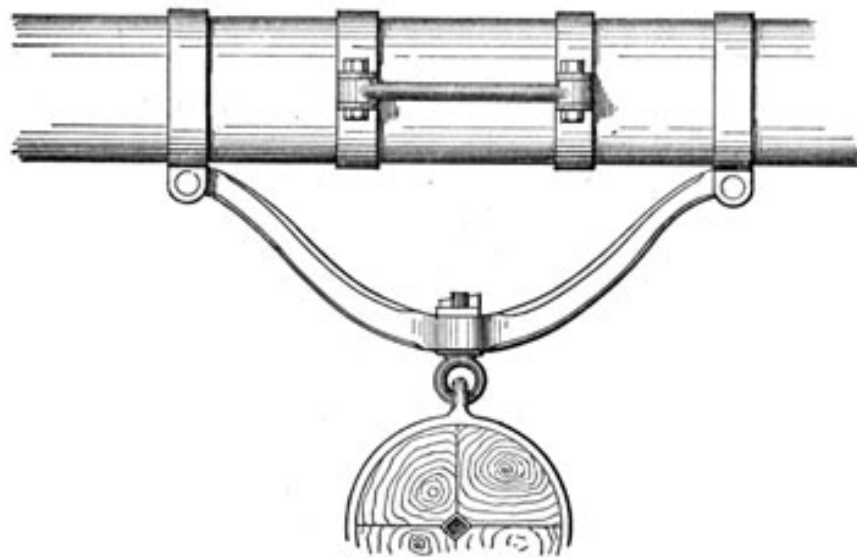


Fig. 338



yard comes over the rail, cast off the stops in succession; the pendant easing the yard in to the mast. Use, in addition, a fore-and-aft tackle, and thwartship jiggers to assist in placing the yard across the nettings.*

Sling-bands. These are two stout iron bands going around the yard, each side of and near the centre, and connected by an iron span, to which the slings are attached by means of the slip-hook, or "pelican" hook. Plate 36.

There may be two additional bands, one on each side, for preventer slings, or for the jeer-blocks, if the latter shackle to the yard instead of lashing.

The Chain-slings are sent aloft by one of the top-burtons, and fit over the lower cap in a saddle for the purpose, or they may be fitted with two shackles that secure to the eyes of a crescent, bolted over the cap. A *back-lashing* abaft the mast, about one-third the doublings from the mast-head, keeps the strain on the slings in a vertical direction. Plate 36.

Truss-bands. Iron bands, outside the sling-bands, to which the arms of the truss are secured. sling-bands, also Fig. 338.

Backer and Staple for Head-earring. There is usually an eye in the shoulder-band for the head-earring. In its absence, a grommet strap of small rope is put on the yard-arm *first*, with a thimble seized in on top. Backer of rope plaited, fitted similar to the one on topsail yard.

Lifts, are four-stranded, hemp, blacked. In large ships they are rove as luffs, with the double block at the cap, and single block hooking to the shoulder-band. The standing part hooks to the breech of the yard-arm block, or to a bolt on the shoulder-band. In smaller vessels the lift is a gun-tackle purchase, the standing part hooking to the breech of the upper block. Lower lift blocks at the cap are of iron, the fore usually has additional sheaves (the *after* ones) for the lower boom topping lift.

The end of the lift on deck is turned up around a thimble, into which a double (or lighter) purchase is hooked.

Brace-blocks. Iron strapped, with friction-rollers, hook to shoulder-band, sheave up and down.

Quarter-Blocks for the topsail-sheets, are iron-strapped and shackle to the band, underneath the yard,

* For the *main* yard the fish-boom is taken aft and the heel secured in one of the jeer bolts forward of the mast. In the case from which this description is taken, the main-yard of the "Colorado" was the spar

handled. There were no precautions necessary, except as above stated in protecting the netting. The ship was in port, at Hong Kong, the waistboats remained hoisted, and the gangway ladder shipped. The spar, 110 feet long and weighing nearly 10 tons, was landed on board inside of 20 minutes. Treble purchase 6-inch fall,; hawser 10-inch, pendant 4 1/2-inch hemp, stops on the yard and hawser 2 1/2-inch manilla. In the absence of the fish-boom, use any suitable spar as an outrigger.

Plate 36. In case of accident to the strap or bolt, seize the quarter-block into a *doubled* grommet-strap with a round seizing, the bights being secured to the yard *on top* by a rose-seizing.

Clew-Garnet-Blocks, Plate 36, are iron-strapped with friction-rollers, and hook to a band around the yard, being *forward* and *inside* of the quarter-blocks. They should be fitted with a link or swivel. In case of accident requiring them to be rope-strapped, use single strap with lashing eyes, the latter seized together on top of the yard.

Quarter-Irons, Fig. 347 *b*, for the topmast-studding-sail-booms, are screwed to iron bands on the yard about two-thirds out, and are fitted to clamp and unclamp around the boom.

Boom Irons for the same spars are keyed to the ends of the pacific-irons, and fitted with a roller in the lower part. Fig. 334, also Fig. 347.

Burton Straps. Iron bands with eyes at top, fitted to the yard inside the sheave for topsail sheets.

Jackstays, both for bending and reefing, are of iron, the former with staples, the latter passing through eye-bolts on the yard above the bending jack-stay.

Foot Ropes. Fitted similar to those on the topsail yard; the outer end hooks to the shoulder-band, Fig. 334. The foot-ropes cross *forward* of the mast, each inner end secured to the opposite arm of the truss and seized to the arm on its own side. The two foot-ropes are seized together where they cross.

The necessary cleats, &c., having been attached to the yard, it is sent aloft by the jeers; should these not be available, use two pendant-tackles. In either case, hook both top-burtons to the burton-straps on the yard, and reeve and man the braces and lifts-the latter rove single until the yard is aloft. Keep the yard clear of the mast by a fore-and-aft tackle.

The jeers are two double (better treble) purchases, the upper blocks in small vessels being secured permanently to the chain slings aloft. (See JEER BLOCKS).

The lower blocks lash around the yard on either side of the slings; the upper blocks hang by long lashings or chain slings from the lower cap, over the forward part of the top rim.

Sway aloft, keeping control of the fore-and-aft tackle; when high enough key the truss, hook the slings, square the yard by the lifts and braces, unhook the jeers, bur-tons, &c.

The cross-jack yard differs somewhat in its fittings from the fore and main, as no sail is set upon it. The braces hook to a band well inside the shoulders, so that the brace (which leads forward) may clear the main topmast back-stays.

Plate 62

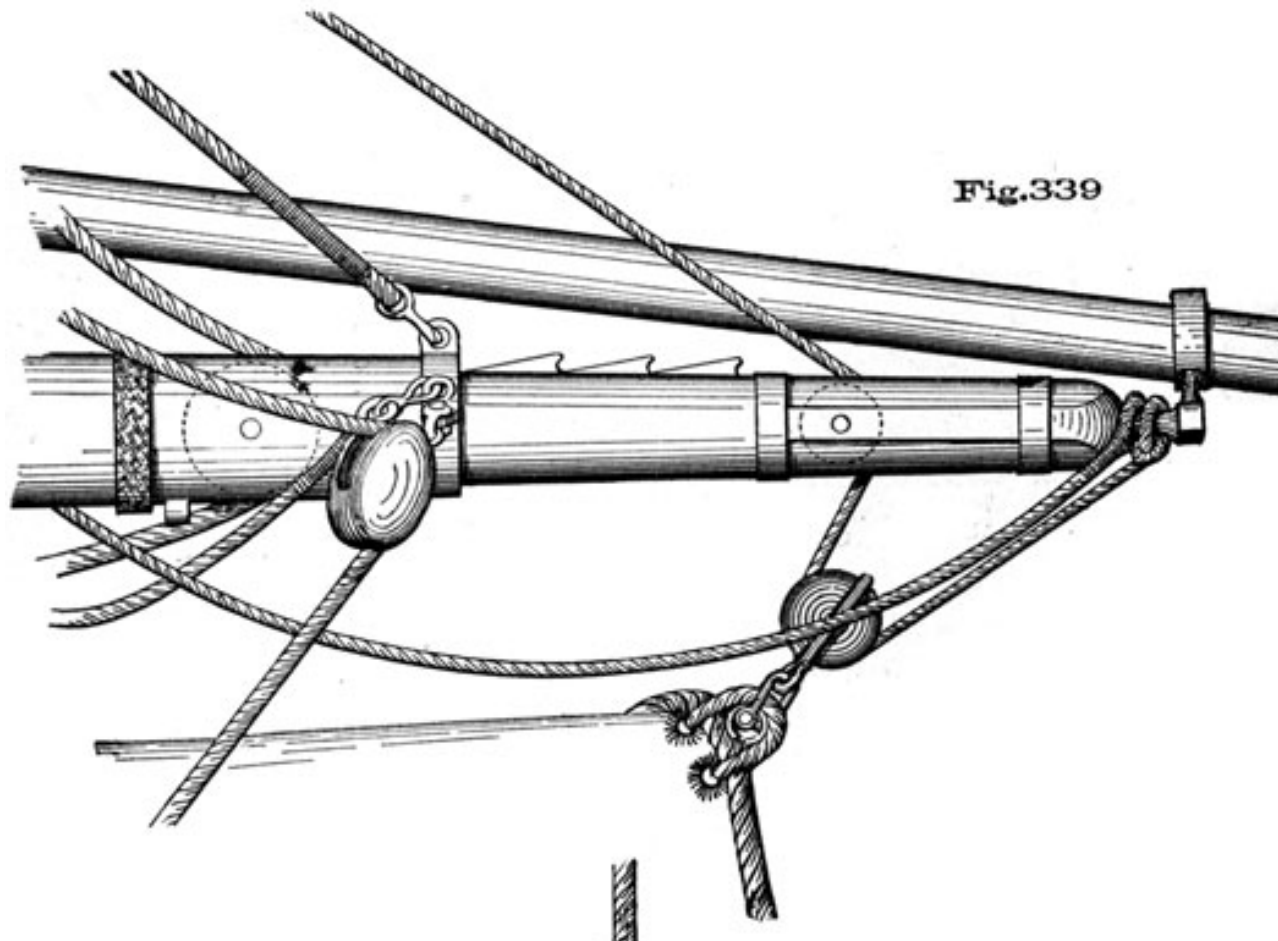


Fig.340

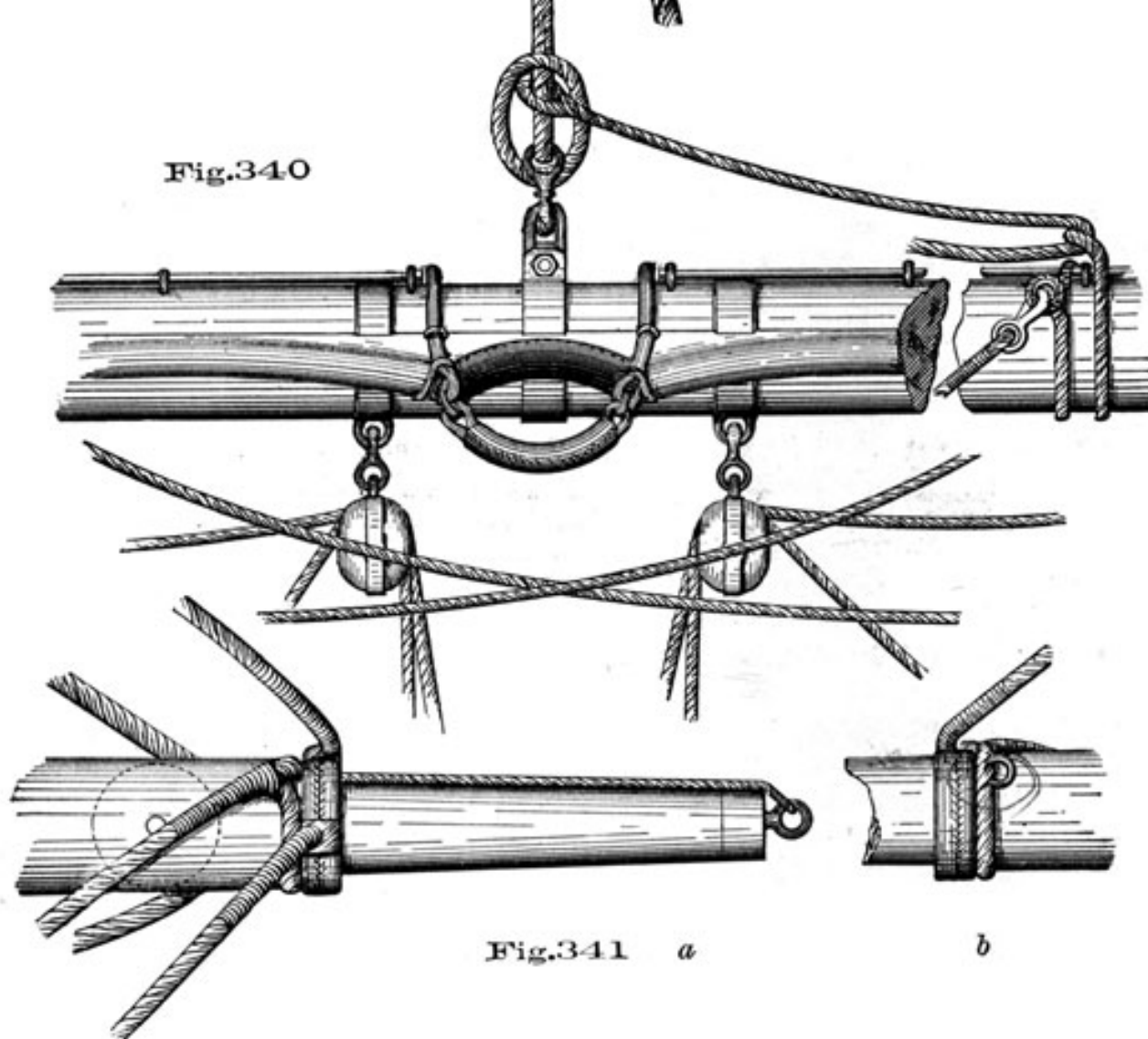


Fig.341 a

b

The cross-jack yard is got on board by a purchase from the topmast head, and swayed aloft by the same purchase and the burtons.

The lower yard is sometimes taken first in order, in rigging ship, but by sending the topsail-yards up first, time may be saved.

Topgallant-Yards. The yard being alongside, sway it on board with the yard-rope, rove through the sheave-hole in the topgallant-masthead, hooking it to the slings, and stopping it down to the forward yard-arm.

The fittings are as follows, Figs. 340 and 341:

Slings. An iron band around the center of the yard, with a link for the hooks on the yard-rope.

Parrel. A grommet on each side of the slings fits around the yard and the jaws, a score being cut in the latter. Both grommets are leathered, and are seized to form eyes abaft, abreast the opening of the jaws. A third grommet strap, also leathered, is seized to one of the eyes, and, when the yard is crossed, passes around the mast, and lashes to the other eye. In port, exercising, a single lashing is substituted for the third grommet-strap. Instead of the first two grommets there might be eyes in the jaws, but these foul in sending the yard up and down, and are liable to get knocked out.

If the topgallant-yard is not provided with jaws the parrel is formed as above, or with a long and short grommet. The larger strap is long enough to go around the yard and meet the short one, being secured by a lashing of small stuff. Both straps leathered.

Quarter Blocks. These are double, iron-strapped, friction-rollers, and hook to a band on the yard.

Strap for the Lizard. A grommet strap slipped over the yard with a thimble seized in the bight, on top of the yard, the strap itself being a few feet from the slings, and called a *quarter-strap*. To prevent slipping this quarter-strap should be seized to the jackstay.

Backer and Cringle for Head-earring. Backer same as on top-sail yard. Instead of a head-earring staple, there is a small cringle worked into the eye of the foot-rope, clear of the royal sheet. Figs. 341, *b*.

Foot-Ropes, Fig. 341. Fitted with eyes to go over the yard-arms. At sea the inner ends generally cross abaft the mast (preventer parrel) and in port they cross forward of the mast. These inner ends are variously secured. They may be fitted with an eye, lashing to the yard with a flat-seizing, eye abaft and on top of the

yard. Or, for convenience in shifting, these ends of the foot-ropes may be fitted, as in Fig. 340, with sister hooks to connect with the thimble of a strap on the quarters of the yard. Or, finally, if the neck of the eye-bolt for the quarter-block is long enough, the ends may hook there.

Bending Jack Stay, of iron. There is no reefing jack-stay.

Lift, Fig. 341 *a*. Single, with a round eye, the splice of which is served. The eye goes over the yard-arm when swayed up for crossing. The lift is cut long enough to reach the top after reeving through the bull's-eye or clump-block between the topgallant shrouds. It is marled to the eye of the brace, so that both lift and brace go on and off together, the double eye being leathered.

The lift and brace may have their ends secured to eyes projecting from an iron ring which is leathered and goes over the yard-arm.

Braces. Fitted with an eye in the end, marled to the lift, or hooked into the iron ring above described. It may be single or a whip and pendant.

Snorters, Fig. 341 *a*, are in length a little less than half the yard, the outer end spliced into the thimble of an eye-bolt at the yard-arm; the inner end has an eye for the tripping-line, and is secured by a stop to the slings when not in use.

To Cross a Topgallant Yard, Fig. 342. The yard rope, having a lizard attached (overhauled down forward, and outside of all), is rove through a good-sized grommet passed over the upper yard-arm and hooked to the link in the sling-band, the lizard being rove through the upper quarter-strap thimble, and hitched to the one on the opposite quarter. Take the eye of the lower lift and brace in the topmast rigging, and that of the upper one to the opposite side of the topmast cap, and sway aloft. When the upper yard-arm rises within reach of the man on the topmast cap, *take off the grommet*, slip on the lifts and braces over the snorters, gathering up the slack of the lower one, and sway away until the slings of the yard are well above the topmast cap, take through the slack of the lower lift, then take a turn of the parrel-lashing abaft the mast, through the eye in the opposite strap, tend the lifts and braces, slack up the lizard, and "sway across," squaring the yard, and passing the parrel for a full due.

NOTE.-The outer ends of snorters are generally plaited like sennit, that they may lie flat, and permit the eye of the lift and brace to fit over snugly.

Royal Yards. The routine of rigging and crossing is precisely similar to that of the topgallant yards; the differences being that the quarter-blocks are single, there are no backers, and the foot-ropes never cross abaft the mast.

In many ships small hand grommets are worked around the jack-stays for the men to hold on by when at sea.

Plate 63

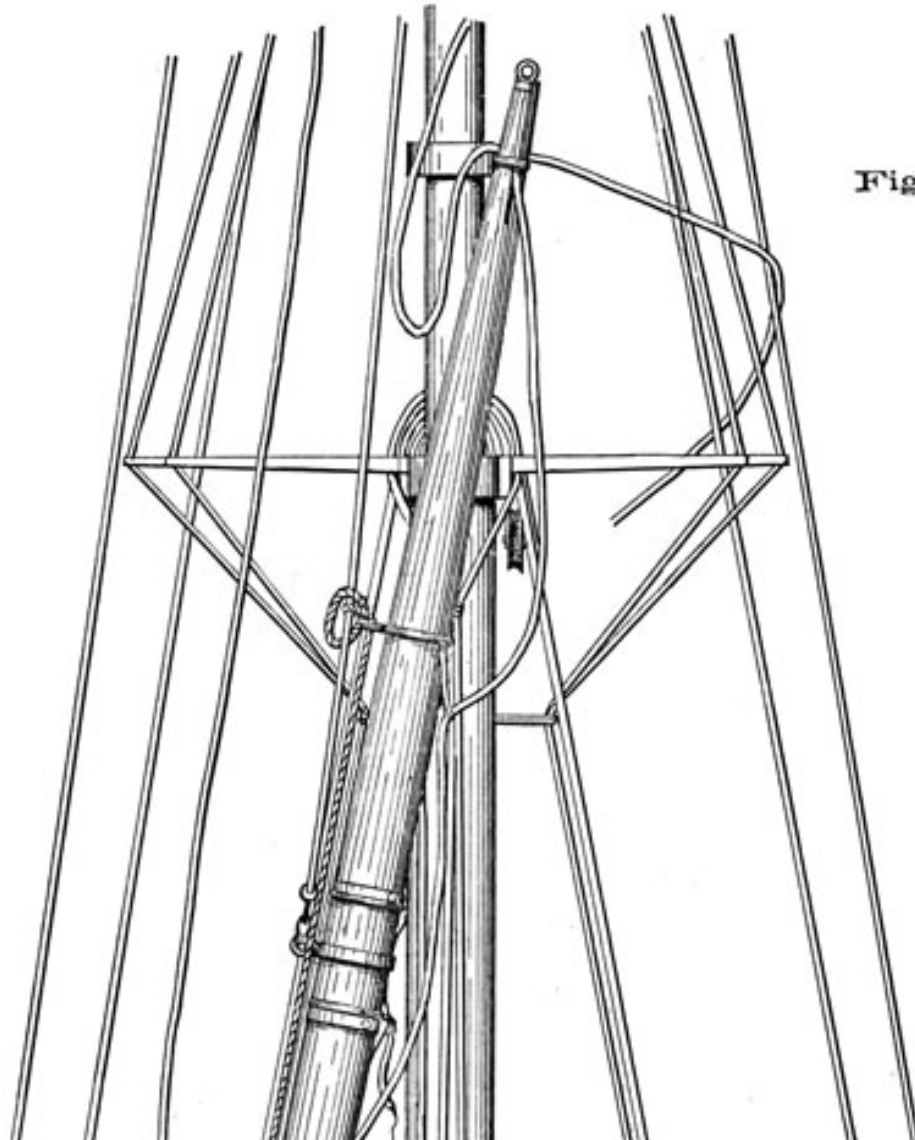


Fig.342

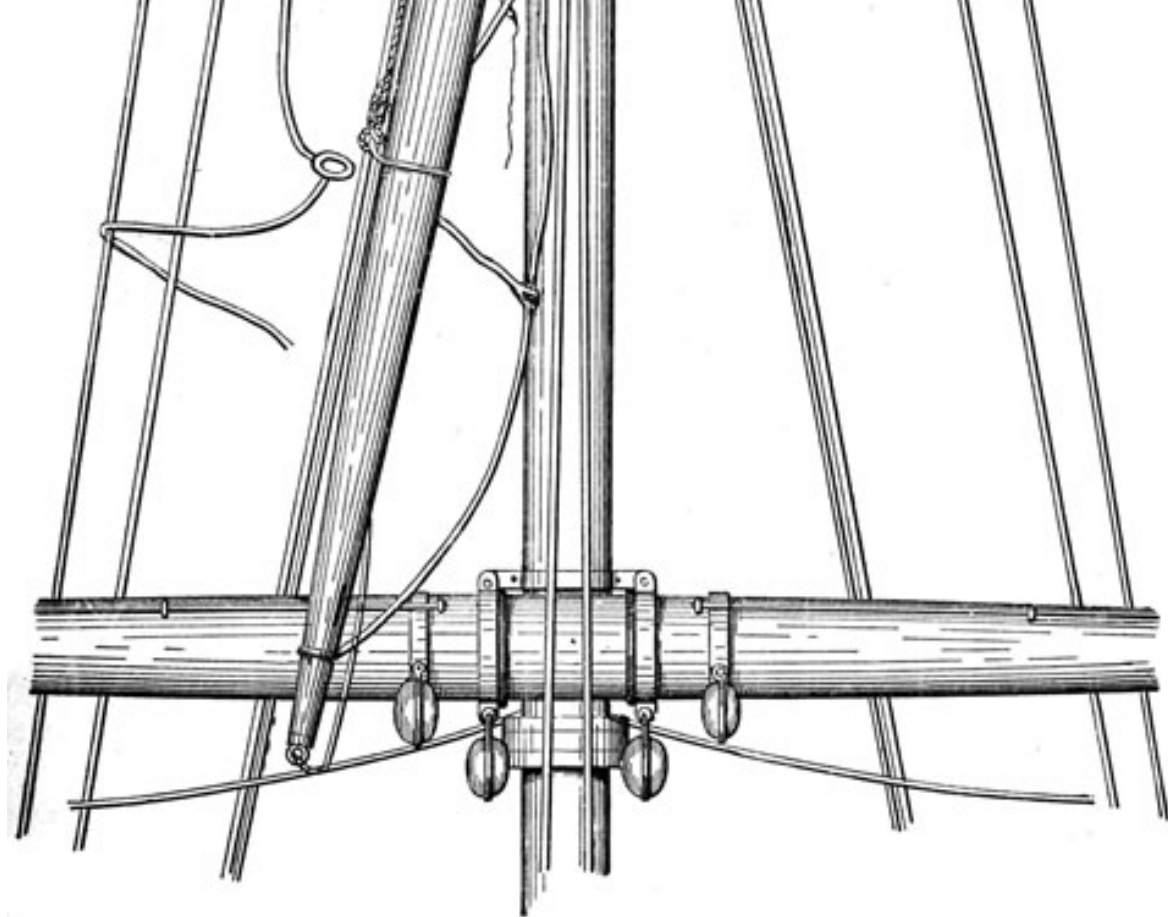


Plate 64

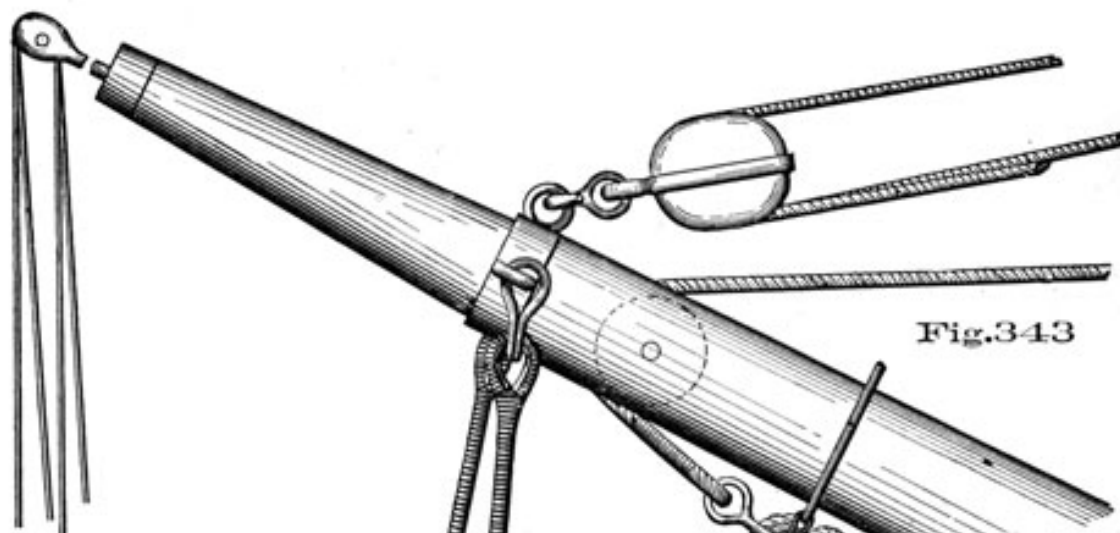


Fig.343

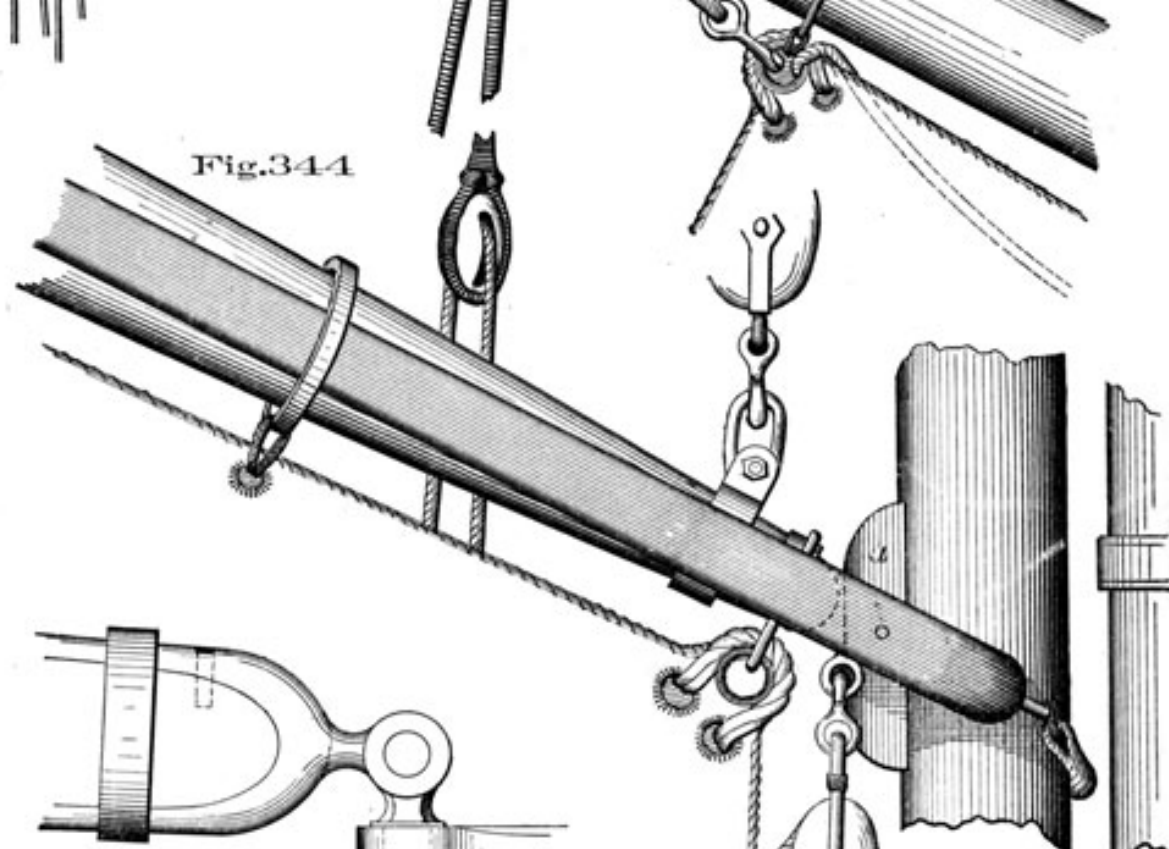


Fig.344

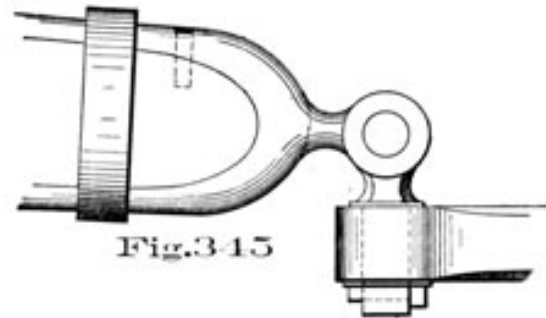


Fig.345

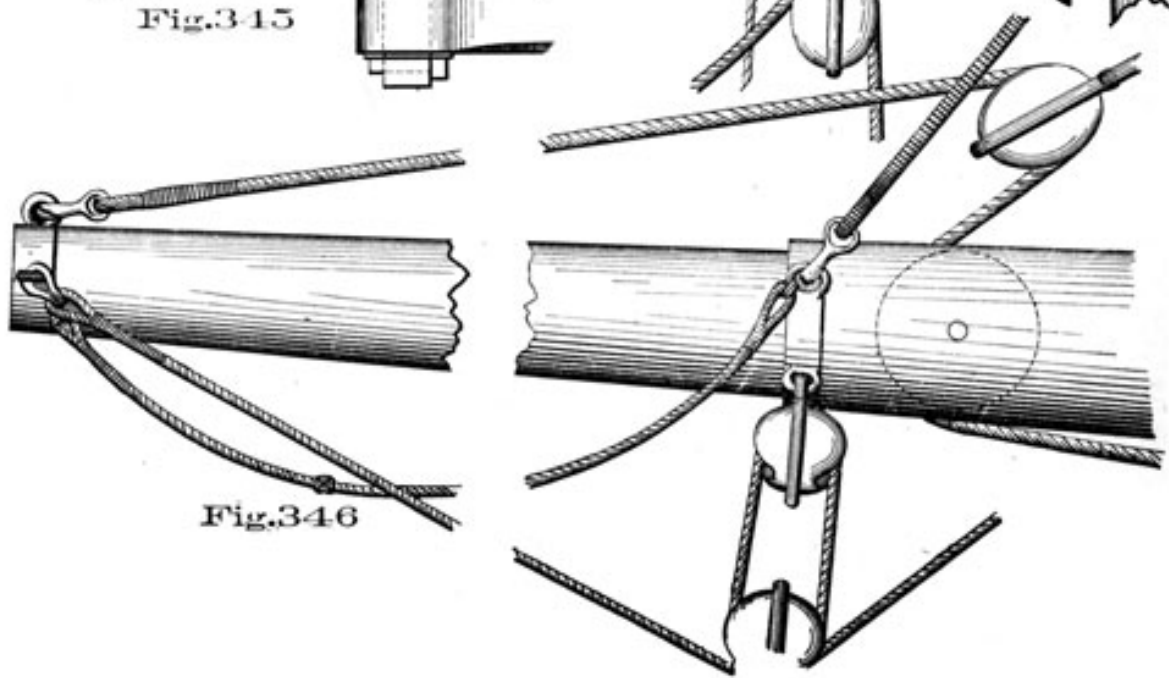


Fig.346

TRYSAIL-MASTS, GAFFS AND BOOMS.

These spars are usually swayed on board by means of the fore or main yard and stay tackles; purchases most frequently in use, and convenient at this stage of the equipment.

Trysail-Masts. The trysail-mast is shipped by means of a tackle hooked to a strap above the futtock-band, the head being pointed through a hole in the after-chock, and the heel (over which the hoops are passed) stepped in a socket or mortise, on the fife-rail, or on the deck. After which, the head is secured by a lashing through a B-cleat underneath the top, or with iron keys; copper having been put on in the wake of the gaff.

The spanker-mast may be fitted with an iron spindle in the heel, stepping into the heel-strap of the spanker-boom.

Gaffs. Figs. 343 and 344. The plan at present generally adopted in the service for trysail and spanker gaffs is to fit them with jaws and in connection with a trysail-mast, there being hoops on the gaff and trysail-mast for bending the sail. Gaffs may be seen in some vessels secured directly to the lower mast by means of eye-bolts within each other, like lock thimbles. Another plan is to have a scored batten secured on the after side of the mast in place of a trysail-mast, with metal slides furnished with bending loops sliding up and down in the groove of the batten. In this case the gaff attaches to a sliding chock, which also moves up and down in the score of the batten, "railway fashion," as it is termed.

The ordinary gaff first described may be fitted with a permanent span of wire rope or chain, from the shoulder band to the after part of the cap, and a similar throat pendant shackling to the upper part of the gaff between the jaws and to a bolt under the top; or, the span and throat pendant may be replaced by peak and throat halliards, sometimes rove in one, as described under running rigging. The blocks for these halliards are iron-strapped.

Vangs are fitted with a pendant that hooks into a band on the shoulder of the gaff.

The vang pendants having been hooked, the gaff is sent aloft by means of its halliards, or by a top burton hooked into a strap around the peak pendant and another tackle from under the top, shackling the pendants as soon as the gaff is aloft, and passing the jaw rope or parrel.

In view of the frequent use of trysail gaffs as derricks in raising weights through the hatches which they plumb, the gaffs and their fittings should be as substantial as possible.

A very important part of the fitting of a gaff is the saddle (a), Fig. 344, Plate 64. This consists of a block of wood, which bolts in between the jaws and is hollowed out

136

to fit the mast. It facilitates the hoisting of the gaff, for at whatever angle it may be, the same smooth surface of the saddle is presented to the mast.

Saddles are particularly useful in small vessels where the gaff is frequently lowered and hoisted.

The *spanker*-gaff should always be fitted with throat and peak halliards to hoist and lower, as necessary; for otherwise it would be almost impossible to reef the sail. In brigantines and schooners it is not unfrequently the case that eye-bolts are attached to each side of the jaws, for preventer lashings in heavy weather; and a single block (grommet-strapped) is put over the gaff end for a down-haul; vang being dispensed with as useless, on account of the sharp angle at which they act, in consequence of the height of the gaff.

Booms. That for the *spanker* is neatest if shipped with a goose-neck to an eye-bolt on the mizzen-mast, Fig. 345, and fitted with an iron band over the boom-end for the topping-lift and the guys, both of which connect to it with sister hooks. The *sheet-blocks* are best if strapped with rope-grommets, on account of the jerks and checks in jibbing, which render eye-bolts liable to snap and break at the neck. These blocks are fitted with clip-hooks if the eye is up and down. The foot-ropes hook into a band on the boom end, and seize to eyes on the sheet band. Fig. 346.

The topping-lifts (one on each side) are usually fitted with sister hooks in the end and hook to an iron band, about one-fifth of the extreme length of the boom from the outer end; while the running parts reeve through blocks at each side of the mizzen tressle-trees, and thence to the deck, where gun-tackle purchases are attached. In men-of-war of the smaller class, and in the merchant service, the topping-lift is not unfrequently single, and rove through the gaff-end, and a roller in the after-part of the mizzen-topmast tressle-trees; the end is turned up around a thimble into which a jigger is hooked.

On the *main-boom* of brigantines and schooners the topping-lift is usually fitted with the standing part secured at the mainmast-head by hooking in an eye-bolt of the wythe; while the lower end is spliced

around a double block, in which a fall is rove, leading through a single one, and a sheave in the boom. In this class of vessels the clew of the sail shackles to a band around the boom. A heavy strap (which is cleated forward), with thimbles at each side, is put around the boom at the sheet-block for the boom-tackle pendant, which is fitted with a hook in the after-end and a thimble in the forward, and is used only in going large.

The boom is got in its place by means of the *throat*-halliards and topping-lift, assisted by guys and thwartship tackles, as requisite.

Studding-Sail Booms. That for the *lower*

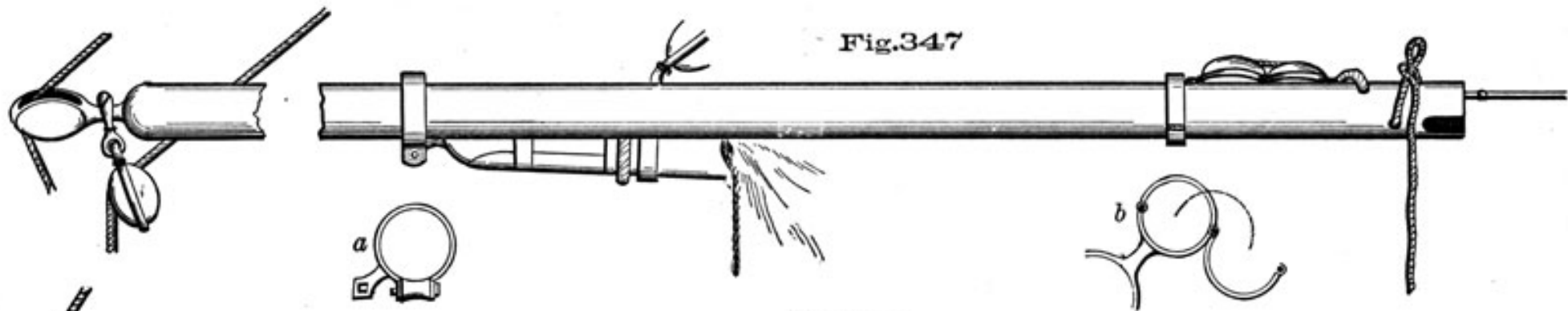


Fig. 347

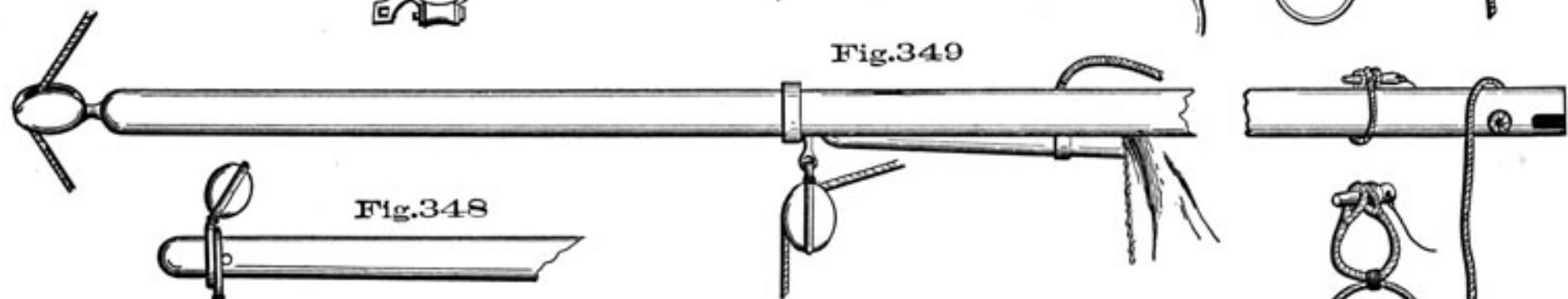


Fig. 349

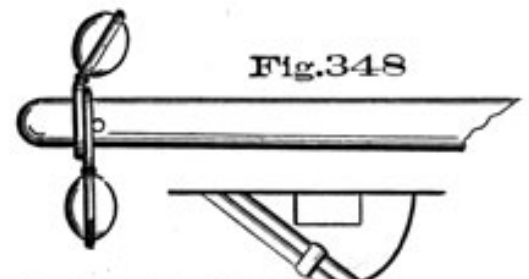


Fig. 348

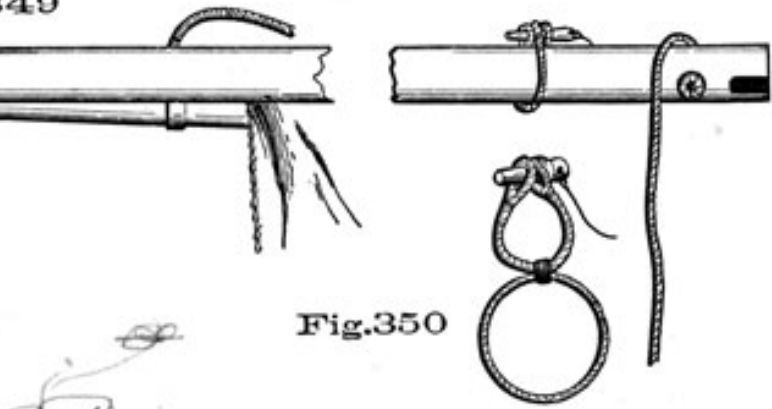


Fig. 350

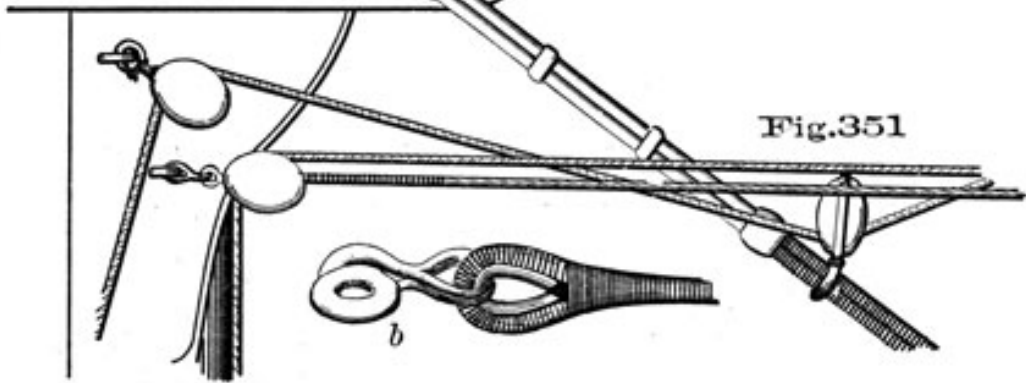


Fig. 351

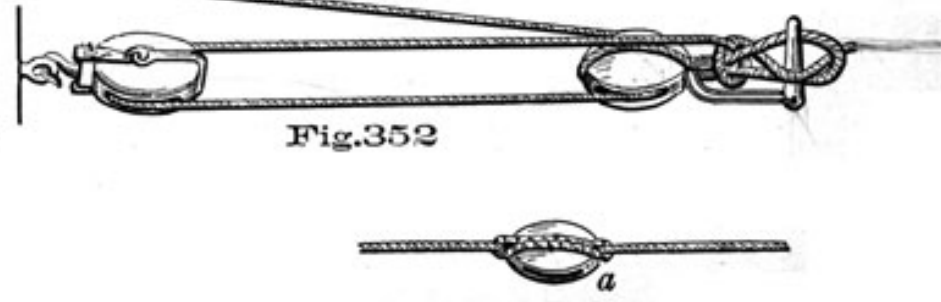


Fig. 352

studding-sail is fitted with an iron goose-neck and key, which connects to a bolt in the forward part of the fore-channels, and is shipped either by means of the fore and main yard-tackles, or with tackles on the fore topmast back-stay and forward swifter of the fore-rigging. On the outer end, about two-thirds from the goose-neck, an iron band is fitted on the boom, having eye-bolts on the forward, upper, and after sides, for the topping-lift and the guy-blocks; *mooring* pendants with large thimbles in the lower ends for the boats, and a Jacob's ladder are hooked, when in port, to the boom. The eyes for the pendants are underneath the boom, and those for the Jacob's ladder are on the upper after side.

The topping-lift is of hemp, it hooks to the *upper* eyebolt in the band on the boom, reeves through a metal block hooked to an eye in the bolt which shackles the fore brace-block to the yard, thence through a block at the lower cap, usually the *after* sheave of the lift-block. The inboard end of the topping-lift is turned up around a thimble, into which a purchase is hooked.

The guy-blocks are iron-strapped and hook to the band.

When the boom is rigged out in port a life-line is seized to the topping-lift, about breast-high from the boom, with its inner end secured inboard in the chains, in line with the boom.

When the boom is not in use it is hauled alongside by the after-guy, and rests in cranes, shipped for the purpose in the waist, the topping-lift being unhooked and triced up out of the way.

The lower boom is so called at sea, and is known as the *swinging*-boom in port.

Topmast Studding-Sail Booms. Round, spruce, or yellow pine spars, unpainted excepting their projecting ends. The outer end is fitted with a permanent tack block, swivelled upon it, Fig. 347, and in line with the axis of the boom, or else there is an iron pin driven through the boom vertically, near its outer end, Fig. 348.

The inner end, or heel, has a deep score for a heel-lashing when the boom is rigged out. Outside of this score there are two holes bored in the boom, one up and down, and one fore and aft, Fig. 347. A grommet strap is worked through each hole, one having a thimble for the in-and-out jigger, and the other a thimble for the tricing-line.

The inner strap is fitted through the hole bored fore and aft, in line with the score. It is used for the boom tricing-line. Splice a heel-rope around the neck of this inner strap.

Unclamp the quarter iron, Fig. 347 *b*, on the yard, and prepare for sending the boom aloft.

Carry out a whip on the fore-yard, secure it well up on the fore-lift. Hook a clew-jigger from the lower cap to one of the grommets on the heel of the boom; the whip from the fore-yard is hitched to the boom far enough out to clear

the quarter-iron, using the heel-lashing for a back-lashing. Have a guy from forward, sway away on whip and clew-jigger, keeping the outer end uppermost. Land the boom on the quarter-iron. Now sway up on the heel and point the boom fair through the boom-iron. The blocks for the lower studding-sail halliards and topmast studding-sail tack, when placed, go over with straps fitted to go neatly around the boom-end, and are kept from slipping in by the iron pin above referred to.

When the tack-block is a permanent one, with a swivel, the halliard-block hooks with sister-hooks to the neck of the swivel for the tack.

The above blocks are taken off in port, except the swivelling tack-block, which, when fitted, is a fixture.

Clamp the quarter-irons, hook the boom tricing-line, rig out to the square mark and take off the clew jigger and whip. Lastly, seize a hook horizontally on the yard, just inside the burton strap, with the point outboard, for the purpose of securing the boom, when setting the sail,* and shift the in-and-out jigger ready for use.

Top-gallant Studding-sail Booms, Fig. 349, are rigged nearly in the same manner, but have no halliard-block at the outer end, and the tricing-line goes directly through the inner hole in the boom (no grommet), with a Mathew Walker knot in the end. There is no quarter-iron; instead, a quarter-strap of rope may be fitted. This forms a figure eight around the yard and boom, seized where it crosses on the yard. One end is split to form two eyes. The other end has one eye (all eyes leathered), and the two ends are held together, when the boom is rigged out, by a toggle. The toggle is taken out as soon as the boom is rigged in, to be ready for tricing up. Fig. 350.

Instead of the rope quarter-strap, some ships use a rope jackstay, seized to the eye of the topsail lift, and set up to its opposite in the slings of the yard. In this case a becket is fitted in the heel of the boom, which toggles to a travelling bull's-eye on the jackstay.

The *tricing-line* leads from the top up through a single block seized to the forward swifter of the topmast rigging, close up to the eyes, thence down to the boom, where it is rove through a single block, and is then

secured to the heel of the boom. When it is required to rig the boom out, the tricing-line is converted into an *in-and-out jigger*, thus:- The tricing-line is let go in the top, and the single block, through which it passes at the heel of the boom, is taken out on the yard, taking out the bight of the tricing-line with it, and hooks to a thimble on the yard.

The boom, when required for setting the sail, is secured

* The heel-lashing is passed over the hook, and back through the score in the boom, and two half-hitches taken with the end around all parts.

139

by means of a lashing passed over a hook on the yard, like that for the topmast studding-sail boom, already mentioned.

The booms on the topsail-yard are usually sent up by the halliards, rove through a block, secured to the forward-swifter of the topmast rigging, the boom being slung in a span.

RUNNING RIGGING.

Besides enabling us to measure for and cut standing rigging, a fore-and-aft draft of the ship gives the length of all running rigging. To measure for main-topsail clew-lines, for example, supposing them to be double, take twice the distance from the clew of the main-topsail, Fig. 284, Plate 43, to the quarter-block on the topsail-yard, to which add the distance thence to the deck, plus end enough to lead out; double this to get the other clew-line and divide by six to reduce it to fathoms, and so for any other rope. One half of each upper yard should be represented as on the cap, in order to measure for lifts, &c.

When a rope leads direct and is not exposed to unnecessary friction, it is said to have a clear or a *fair lead*, an extremely desirable condition, and one too frequently neglected.

Rope supplied in coil has had turns hove in it in the coiling. To get these turns out, the rope must be "thorough-footed." To do this, if the rope is right-handed, lay the coil flat, with that end inside which goes around "with the sun" (to the right), now haul that end up through the coil and coil it down, left-handed. Then dip the new upper end down through and coil again left-handed, and repeat a third time. The rope is then stretched, and the gear cut and rove off. First in importance may be mentioned:

BRACES.

Fore-Braces, Fig. 351. Hemp, left-handed, standing part of wire to extend forward of smoke-stack. Standing part hooks to eye-bolts in the bibbs or to the neck of the brace-block bolt at the bibbs, as in Fig. 351b, thence through blocks on the yard from *up*, *down*, back through other blocks on the outside of bibbs and down to sheaves in the five-rail (usually from *aft*, *forward*).

Main-Braces. Standing part hooked into the bumpkins aft, or into an eye in the breech of the block, then through brace-blocks from *down*, *up*, back to others on the bumpkin (*inside* the standing parts) and through sheaves or leaders in the bulwarks.

On board large ships where there is much drift to the

main-brace, it will be found very convenient to fit the standing part with a jigger, thus: Into the end of the brace splice a single block, and to the eye in the strap of the brace-block on the bumpkin, hook the double block of a jigger. Reeve the fall, the hauling part leading in through the bulwarks with the hauling part of the main-brace. After hauling the main-brace moderately taut in the usual way, a few hands on the jigger fall on the standing part will get the brace as taut as desirable.* Fig. 353.

It is usual to have a permanent timenoguy** leading from the mizzen rigging to the main-brace, the object being to keep the bight of the brace from fouling the quarter-davits while working ship.

The same has been found needful on board very long ships in the main rigging to avoid fouling the waist davits.

The timenoguy is seized to the standing part of the brace, the hauling part reeving through a thimble.

Cross-jack Braces. The standing parts hooked into the strap of a *double* block*** hooked to an eye-bolt on each side of the mainmast, in a line with the yard****-thence to the brace-blocks from *down*, *up*, and back to the inner sheaves of those on the mainmast.

Fore-topsail Braces. Standing parts fitted with eye-splices lashed together abaft the main topmast-head, laid along in the doublings of the collar of the main topmast-stay, and stopped down on each side to and below the crotch, to avoid chafe from the foot of the sail and brace blocks; thence forward and *down*

through the brace-blocks to clump-blocks, seized to the main-stay, Fig. 351, at the fork. Thence through blocks at the bibbs to the main fife-rail. Lead there through sheaves, usually from *forward, aft*.

Main-topsail Braces. Standing part hooks to an iron traveller, which moves up and down the mizzen topmast to shift the strain lower down as it becomes greater (if the mizzen-topsail is reefed or taken in), thence to the yard and down to hanging blocks on the mizzen-mast, about half way between the top and the deck.

Mizzen-topsail Braces. The standing parts hook to the strap of a block at each side of the main cap; thence to the yard from *down, up*, back to the blocks, and so down through the lubber's-hole to the deck.

All the above braces are of hemp, left-handed.

Fore-top-gallant Braces are usually rove single, the standing parts going over the yard-arms with

* The same principle may be variously applied, as to a main-tack, the sheet of a schooner's lug foresail, &c.

** A timenoguy is any piece of rope placed to prevent rigging from chafing or fouling.

*** The outer sheave is for the mizzen top-bowline.

**** Otherwise, the angular action of the brace would cant the yard either up or down, and consequently slack one or the other of the mizzen-topsail leeches.

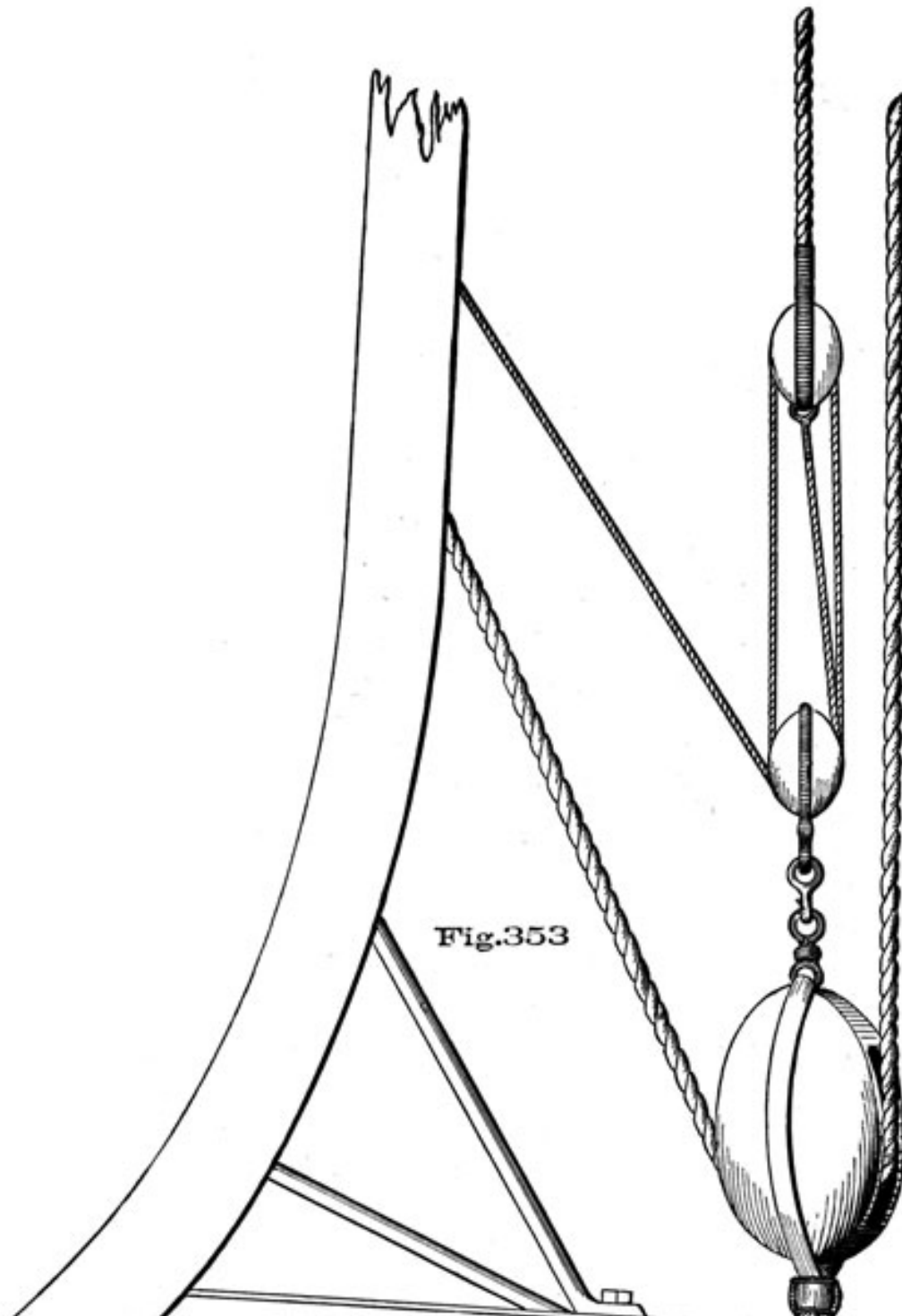


Fig.353



MAIN BRACE OF A FIRST RATE

Plate 67

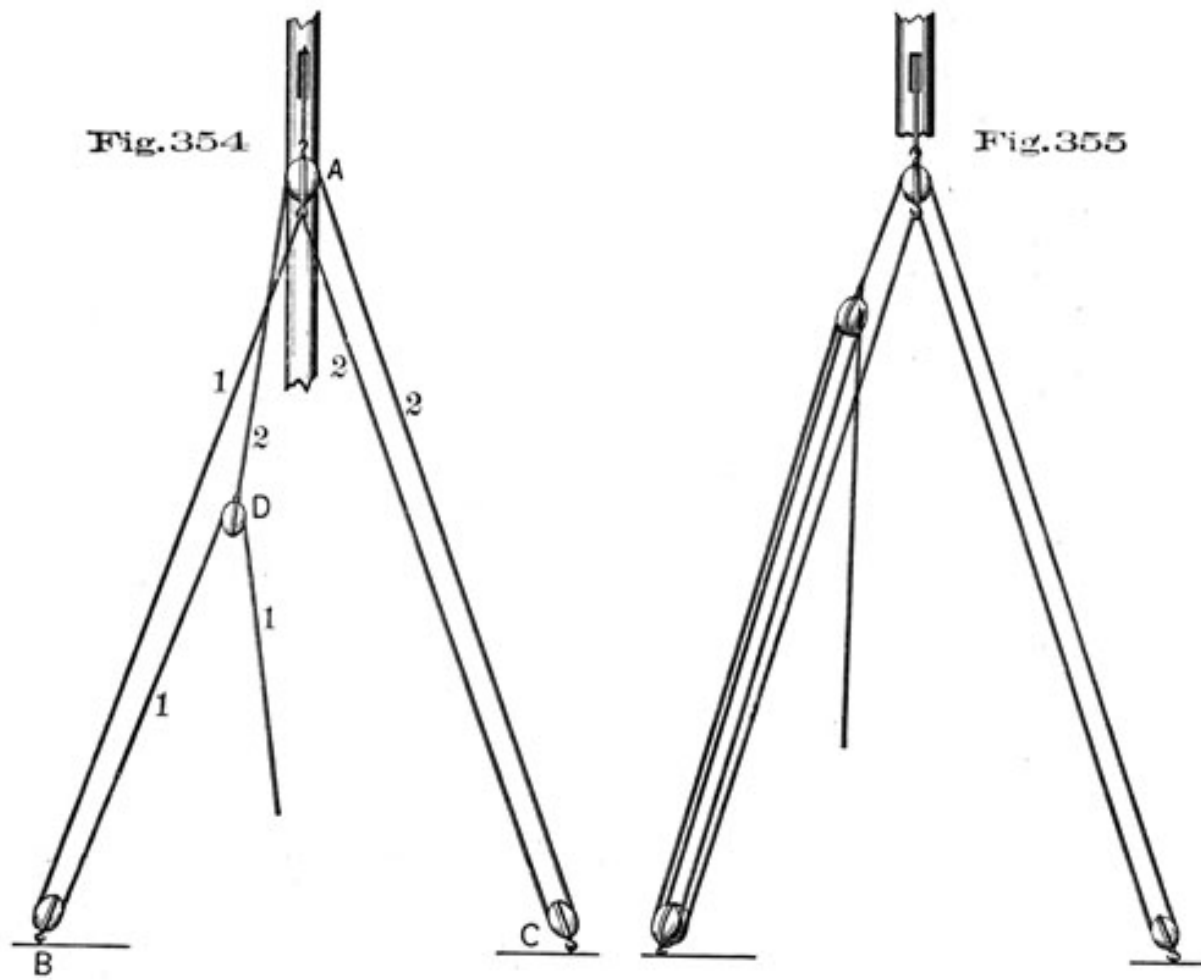
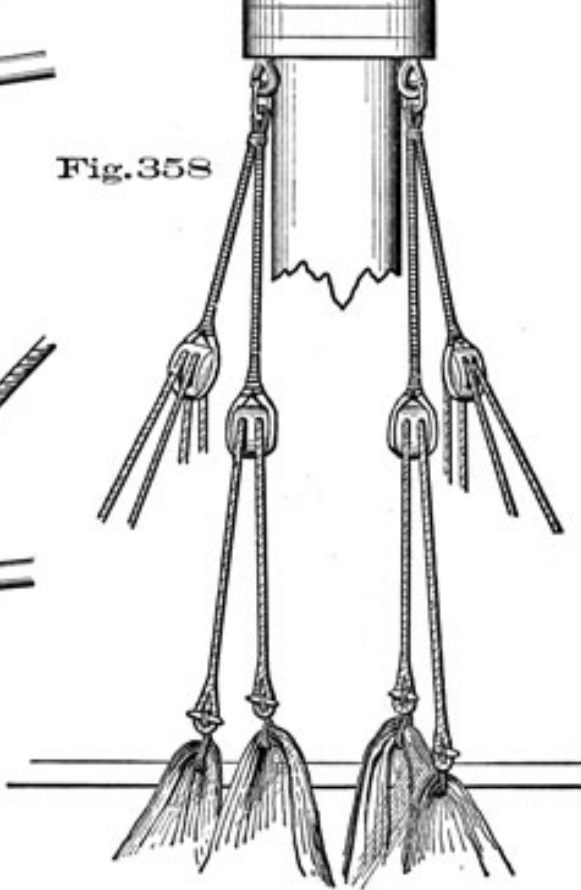
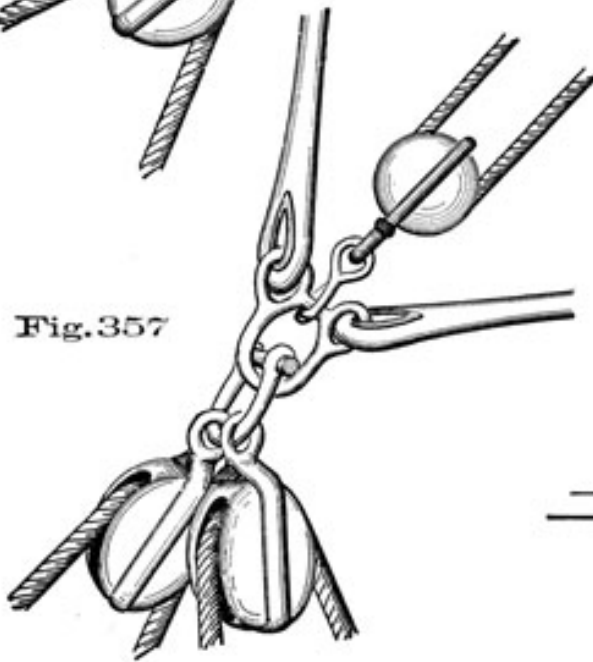
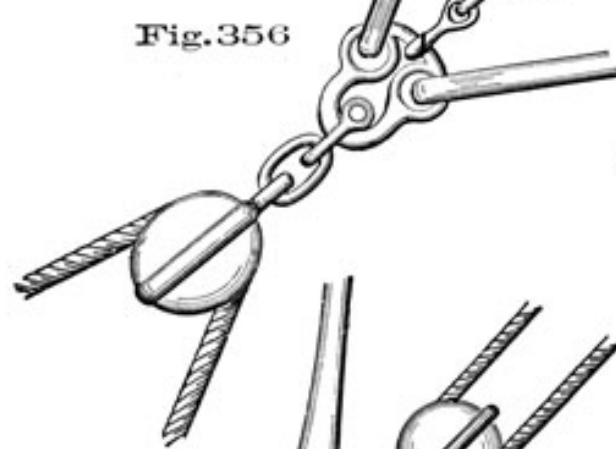


Fig. 356





the lifts, thence through span-blocks on the main-topmast-stay collar, and others, under the eyes of the topmast rigging-whips (the standing parts of which are secured to the deck) being attached to the ends, in large ships. The whip-blocks should be iron bound with swivel-eyes. Brace of hemp, whip manilla.

Main-top-gallant Braces. *Vide* preceding, and substitute *mizzen* for "main." Brace hemp, whip manilla.

Mizzen-top-gallant Braces. Through small blocks, underneath the main-topmast cross-trees, or seized to the main-topmast backstays. Brace single, manilla rope.

Fore-royal Braces are single (without whips), and rove like the top-gallant braces, except that they are taken to the main-top-gallant mast-head. The blocks are now generally made of metal, and hook to eyes in the funnel, or are seized to the top-gallant rigging.

Main-royal Braces. Same as fore-royal braces, except taken to *mizzen*-top-gallant mast-head.

Mizzen-royal Braces. Single. and through sheaves in the after-chock of the main-topmast cross-trees. All royal braces are of manilla rope.

Topmast Studding-sail-boom Braces may be either single, going over the boom-end with a running-eye and leading through a tail-block on the forward swifter of the main rigging; or double, with a pendant and whip leading to the main rigging.

Preventer Braces are fitted with a *pendant* and *whip*, the former going round the yard, hooking to its own part, and the latter led to the deck, well aft, when for bad weather. When rove for action, they are led forward.

HALLIARDS.

Topsail-Halliards. Where double tyes and gins are used, the standing part of the halliards is spliced to a single block (which is iron-strapped and fitted with a swivel), in the channels, on each side, and then rove through a double one hooked to a thimble in the end of its respective tye. A double purchase is used in heavy ships.*

* Bell's purchase, as usually fitted for the mizzen-topsail halliards. The tye used is single, of flexible wire, reeving through the sheave in the topmast. The four blocks are single (see Fig. 354); block A shackles into tye abaft the mast, blocks B and C are in the after part of the mizzen chains, one on each side of the ship; block D is at the height of the lower mast-head when the topsail-yard is on the cap, but close down to the

leading block on deck when the yard is hoisted. The parts marked 1 and 2 are securely seized together at A. Power gained is as 7 to 1, friction not considered. Fig. 355 shows a similar purchase for heavier yards.

Top-gallant Halliards; rove off on going to sea. The top-gallant yard ropes being rove in the jack-blocks, a "short yard rope" reeves through the sheave in the mast with sister-hooks in one end, hooking to the slings of the yard, and a thimble is then seized into the other end, for the top-gallant purchase. This is a tackle hooked into the lower trestle-trees, fall sent on deck. To unreeve the short yard rope on going into port, turn out the thimble.

The long yard rope is coiled down in the top, ready for use in sending down the yard if necessary.

Royal-Halliards are best, if fitted with a gun-tackle purchase, thus: The yard-rope, being rove in a leader on deck, is passed through a single block fitted with a strap having an eye, and toggled on abreast the top, as represented in Fig. 352, Plate 65. In the event, then, of having to send the yard down, it is only necessary to take off the, block, which will leave the yard-rope clear for running.

The strap of the block may be a temporary one and made of a selvagee and the yard-rope, Fig. 352 (a).

Throat-Halliards. If for a spanker or trysail, they usually consist of a purchase rove through double and single blocks; the former hooked to a bolt on the under side of the after lower chock, and the latter to a band and eye-bolt at the jaws of the gaff; the hauling part leading through the upper block from *aft forward*, to the deck. In brigantines and vessels with a boom-mainsail, both blocks are double,

Peak-Halliards. The best plan for peak-halliards is to reeve them as follows: Hook the standing part into the breech of the mast-head block (which is double), and reeve thence through the *inner* block of the gaff, from *aft forward*; then up through the *port* sheave of the mast-head block, out through the block at the gaff-end, from *forward aft*; and lastly, back to the sheave of the mast-head block.

The merit of this system will be apparent, if we consider that the hauling part, by being rove *last*, at the gaff-end, permits the peak to drop the instant the halliards are let go.

The standing part may be rove through the *third* sheave of the block (treble) at mast-head, and have a small single block spliced in the end, through which reeve a whip; this enables the peak to be pulled up taut. The latter plan is adopted by all large schooners and sloops, and is on the same principle as applying

a purchase to the standing part of the main brace.

Storm-Staysail Halliards. The fore-storm staysail-stay, fitted of rope of the proper size, having in its upper end a stout iron toggle covered with leather, toggles into the crotch of the fore-stay. The lower end, after passing through the hanks of the sail, reeves through a stout bull's-eye strapped to the bowsprit, and sets up with a luff. The halliards are sometimes a luff, and sometimes a gun-tackle

purchase. The lower block hooks to the head-crinkle of the sail, the upper to an eye-bolt under the top, or to a strap around the collar of the fore-stay.

This gear is rove only on the probabilities of bad weather.

Jib arid Topmast-Staysail Halliards are rove through the upper sheave of iron fiddle-blocks, hooked to a bolt in each side of the topmast trestle-trees, thence through hanging blocks in the after-part of the trestle-trees, to keep them clear of the topsail tyes and lifts. The jib-halliards are double, and reeve through a block in the head of the sail, with the standing part half-hitched and lashed to the crotch of the stay collar. Halliards of manilla. The staysail-halliards are single, with sister-hooks to the head-crinkle and a whip, the block of which comes just below the hanging block when the sail is taken in. Pendant hemp, whip manilla.

The lower sheaves of the fiddle-blocks serve for the topsail buntlines.

The jib-halliards should be led on the *starboard* side, and those for the staysail on the port-a rule which is self-evident, when we remember that the latter is set on the *port* topmast-stay. The method of fitting these halliards with *whips*, is not approved of by seamen generally, on account of the liability to tangle and get foul in hauling down the sail; and the obvious necessity of separating the parts widely from each other.

NOTE. Whenever a whip is used, as in the foregoing, it is well to use an iron-strapped swivel-block, splicing the pendant into the eye of the swivel, to avoid cable-laying.

Flying-Jib Halliards, manilla, are rove single, through a small iron fiddle-block hooked to an eye in the lower rim of the funnel (on the *port* side) under the eyes of the rigging, and connected to the head-crinkle on the sail by means of sister-hooks. In large ships, however, they are sometimes rove double, and the standing part seized to the splice of the stay on the *under* side. The small iron fiddle-blocks are for flying-

jib halliards, topgallant buntlines, and topgallant bunt-jigger.

All iron hanging blocks, like those above described for head halliards, as well as those for the topsail-tyes, are commonly known as "*gin*" blocks.

Gaff-topsail Halliards are single, and in barks and ships, are rove through a sheave in the topgallant mast-head, and attached to the yard with a fisherman's bend; or if the sail is triangular in shape, to the headcringle, with a sheet-bend. On board of schooners and hermaphrodite brigs, they are rove through a sheave in the topmast-head.

Lower Studding-Sail Halliards. The *outer halliards* reeve through the lower sheave of a fiddle-block, which is strapped with a long pendant, and hooks to

a strap around the topmast-head above the eyes of the rigging; thence to the halliard-block at the end of the topmast studding-sail-boom, and attached to the yard with a fisherman's bend, or a studding-sail halliard-bend. The upper sheave of the fiddle-block is for the topmast studdingsail-boom topping-lift, when one is used. Or they are rove through a span lock on each side, which is secured with lashing-eyes above the topmast rigging, and forward of the shrouds, the hoisting part leading on deck through the cross-trees and the lubber's-hole. The *inner* halliards are usually formed out of the fore clew-jigger, hooked to the inner head-crangle of the sail and to the cap.

Topmast Studding-Sail Halliards are rove on each side through a single block hooked to the topmast cap; thence *abaft* the topsail-yard, through the jewel-block, and so to the deck, where they are attached to the central part of the studding-sail yard with a fisherman's or studding-sail halliard-bend.

By Plate 32, the halliard-block may hook to the link in the crescent on the topmast cap.

Topgallant Studding-Sail Halliards are rove on each side, through a single block (which is fitted with a rope-strap and tail), hitched above the eyes of the topgallant rigging; thence *abaft*, to the jewel-block, and so to the top, where they are bent to the studding-sail yard, in the same manner as the halliards previously mentioned, the hoisting part being sent down to the deck *abaft*, and clear of all.

The halliard-blocks at the mast-head are much neater when fitted with lashing-eyes.

All the studding-sail halliards are manilla.

SHEETS.

Fore and Main Sheets. The standing parts are connected to eye-bolts on the outside of the bulwarks with sister-hooks, just *forward* of the sheaves for the hauling parts; thence they are rove *up* through the blocks at the clews of the sail, and back, inboard through the bulwark sheaves. Hemp, tapered. Fig. 357.

Topsail Sheets. When double, as on board of first-rates, the standing parts are clinched around their own parts and go around the yard-arms *outside* of all, and thence rove from *out in*, through the sheet blocks to the yard sheaves, and the quarter-blocks in the slings; being led, lastly, to the bitts on deck, forward of the mast. If single, they are simply secured to the clew-tringle with hooks; but where chain is used, they are connected by small stout iron shackles.

Topsail sheets are usually hemp, Fig. 356.

145

Topgallant and Royal Sheets are always single. The former hook to the clews of their respective sails, and the latter have a sennit eye, which fits over a toggle on the clew of the royal. Topgallant sheets reeve through the topsail-yards, to the *after*-sheaves* of the quarter-blocks, thence they are led through the lubber's hole to the deck. Royal sheets are rove in the same way, except through the sheaves and quarter-blocks of the topgallant yards, and thence through thimbles on the futtock-staffs of the topmast rigging (abreast of the *second* shrouds), to the top or deck, as may be preferred.

These sheets are of hemp.

Storm-Staysail Sheets are temporary purchases, and consist usually of stout luffs hooked (and moused) to the clew-tringles, and brought well aft, in order to form, as near as possible, a line with the foot of the sail. The hauling part should then lead from the *forward*-block, by which a greater purchase is obtained; although the reverse of this is advocated by many seamen, on account of the difficulty sometimes experienced in getting a turn with the belaying-end, in consequence of the flapping of the sail; but this objection will be entirely overcome, if the sheet be hauled aft, and the foot taut, before hoisting.

Trysail Sheets. The best plan for fitting these is to have a pendant attached to the clew of the sail for the sheet to hook into, as it saves the trouble of "lighting up" the blocks to hook and unhook in shifting the

sheet, as in wearing ship, &c. The sheet is an ordinary luff and hooks well aft to an eye-bolt in the deck.

Jib wad Topmast-Staysail Sheets. Both of these are fitted with a hemp pendant and manilla gun-tackle purchase, as follows:

The pendant, which is wormed and served, shackles into the clew-iron, and has a single block spliced into the inboard end. The other block of the purchase hooks to an eyebolt in the deck. A third single block is often hooked into the deck abaft the purchase-block, as a leader for the hauling part.**

The deck blocks for the staysail sheets are forward of those for the jib.

The standing parts of these head sheets hook into becketts in the breech of the pendant block.

Flying-jib Sheets, may be single, but are generally

* In vessels where the quarter-blocks are *threefold*, the topgallant sheet is rove in the *middle* sheave.

** The position of the bolts and blocks (or sheaves) must be such, that the sheet, when taut, shall form a line at right angles with the luff of the sail-for otherwise, either the foot or the leech would become slack, and the jib thus be deprived of a great portion of its efficacy. Head sheets should have a cuckold's neck in the end to prevent unreeving, by accident, as in a squall.

10

fitted with a pendant and whip, hemp and manilla. The pendant shackles or hooks into the clew-iron, the standing part of the whip secures to the whisker or to the head-rail, and the whip reeves through a block on the end of the pendant, a thimble on the whisker and in on the forecastle, forward of the stay-sail sheets.

The object of the pendant is to keep the weather whip-block to windward of the stay, if possible, and it is fitted accordingly, sometimes reeving, itself, through the thimble on the whisker, the whip coming inside of it.

Spanker Sheets, are rove in *one* with the guy. The standing parts are hooked to the shoulder-band, and rove to the (double) block in each quarter; thence through the sheet-blocks on the boom from *forward aft*, and back to the second sheaves of the double blocks.

Boom-mainsail Sheets. In small craft, as schooners, &c., a purchase of double-blocks, and working on a traveller, is used; but in larger vessels, two (attached by separate straps, and hooked to eye-bolts in each quarter) are employed to manage the boom-the hauling parts in either case leading from the upper block. This latter method is by far the better, as every one who has had to "jibe" a boom-mainsail, with a single sheet and crotch-ropes, in heavy weather, will bear witness to.

Gaff-topsail Sheets are formed of a single piece of rope, which is middled, and the bight passed through the clew-crinkle of the sail; the ends being thrust also through the bight, are led down on each side of the gaff to a belaying cleat on the boom, near the jaws.

Studding-sail Sheets. Those for the *lower* studding-sail consist of a single piece of rope, passed through the inner clew-crinkle like those for the gaff-topsail (or the two parts may be seized together), and in setting the sail, one sheet is rove from *forward aft*, through a thimble or block on the goose-neck, in order to bring the clew close down to the boom, and the other led inboard over the hammock-rail, on the forecastle, by which to haul on board the sail, when taking it in.

In fitting a *topmast* studding-sail, two sheets are also required, which are attached to the clew in the same manner as those for the lower studding-sail. One (called the *short sheet*), being passed *forward* of the topsail, and *aft* through a thimble (seized to the jack-stay or quarter-iron) on the outer quarter of the lower yard, into the top, where it is belayed to a cleat; and the other, or *deck-sheet*, being led to the forecastle, *forward* of the yard. The sheets and down-haul are always made up with the sail.

The *top-gallant* studding-sail sheet is simply spliced into the clew of the sail (having parcelling on it for two or three feet below, to avoid chafe from the foot-rope of the topsail-yard), and led into the top, where

forward-swifter, or it may be led on deck, where it may be made of much service when taking the sail in, in a fresh breeze. The above sheets are manilla.

TACKS.

Fore and Main Tacks are hemp, tapered, rove double, Fig. 357 (except now and then on board of small vessels, where they are single). The standing part, which is wormed and served for a fathom or so from the end (as a protection from wet), is hooked to the bumpkin* and rove through the tack-block at the clew of the sail-then back through a leading-block inside of the standing part, and a hole in the bulwarks.

Studding-sail Tacks, manilla, hook to the tacks of their respective sails, and are rove from *in out*, through the blocks at the boom-ends. That for the *topmast* studding-sail is led aft, through a tail-block on the forward-swifter of the main-rigging; and the tack of the *top-gallant* studding-sail, through a leader tailed around the dead-eye of the after topmast shroud.

The top-gallant studding-sail tack is *bent*, not hooked.

NOTE. The double block in the main rigging for the tack and boom-brace should not be tailed to the shrouds, as it hauls them out of line and stretches them unduly. It should rather hook to the eye of a long pendant, which hooks far enough aft in the main-chains to form a line with the tack, and passes through a *lizard* at the proper place in the main rigging.

Spanker and Boom-mainsail Tack (Lashings), are passed through the cringle (into which they are spliced), and an eye-bolt on the upper side of the boom.

The spanker-tack lashing is more frequently passed around the spindle of the spanker-mast step.

Trysail-tack Lashings are passed around the foot of the trysail mast, on a line with the foot of the sail, or through an eye-bolt in the after part of the fife-rail.

Where the trysail is fitted "railway-fashion," the lower end of the grooved batten has a chock to keep the sliding hanks in. This chock has an eye for the tack lashings.

NOTE. In laying-to, in a small vessel, under a balanced-reefed (boom) mainsail, the tack of the sail should be lashed up to the jaws of the gaff, and the whole hoisted several feet up the mast by means of the throat-halliards. In this way the sail is elevated to the wind above the waves, and

* The *main* tack hooks to a bolt and block in each of the waterways, or deck, forward of the gangway, being rove like the fore, through the block on the clew of the sail, standing part forward.

148

in the event of being boarded by a quarter sea, it cannot lodge in the belly of the sail, but will pass between it and the boom.

Tacks of Head Sails. All head sails have a cringle in the tack with an iron thimble. To secure the jib tack there is a *bail*, Fig. 333, or horse-shoe of iron, spanning the upper part of the jib-boom, inside the stay. The two ends of the bail have eyes, through which passes the pin for the sheave of the jib-stay. On this bail are sister-hooks, which hook into the tack thimble.

The flying-jib tack is fitted in precisely the same way, the bail being held in its place by the pin of the sheave for the flying-jib stay. Fig. 332.

Both bails have projecting eyes, well down, for the down-haul blocks.

For the staysail is fitted a long strap, with sister-hooks in the upper end. The strap is seized to the topmast-stay, and has drift enough for the foot of the staysail to clear the heel of the jib-boom. The hooks in the strap hook into the staysail tack thimble.

This does away with the necessity of tack lashings.

CLEWLINES.

Clew-Garnets are used only on the courses. Lead from the deck to the clew-garnet block under the yard from *in out*, through the clew block in the sail, standing part taken between the head of the sail and the yard, and made fast to the arm of the truss.

Topsail Clewlines. For small ships may be single, or single with a whip. For large vessels rove as

follows: From the deck through the forward sheave of the quarter-block on the topsail-yard, thence through the clew-line block on the sail, the standing part taken up between the head of the sail and the yard, and made fast to the neck of the tye-block.

It would be far better to have a separate block in the quarter of the yard for the clewline, the same as is fitted for clew-garnets. This enables the clewline to be unhooked and shifted to the cap (as is often done) without interfering with the topgallant sheets. Moreover, such a block has enough play to give a fairer lead to the clewline when the sail is bellied out by a strong breeze, and the sail is always hauled up snugger. Fig. 336 shows such a block, fitted.

Topgallant and Royal Clewlines, are both single, are bent to the clews of the sails, and rove through the quarter-blocks of their respective yards, and thence to the deck by way of the lubber's-hole. Topgallant clewlines rove double in large ships, standing part secured to the neck of the quarter-block.

Lower Studding-sail Clewlines, are simply bent to the clews and reeve *abaft* the sail, through small single blocks on the inner end of each lower studding-sail yard, and thence are led inboard to a tail-block on the forward swifter in wake of the futtock rigging. This clew-line becomes the gear tricing-line when the sail is in. The clewlines are frequently led through a glut in the belly of the sail.

Fore and Main Clew-jiggers. Each consists of a gun-tackle purchase, hooked to the clews of the courses forward and to eye-bolts underneath the forward part of the tops. In furling sails, they are found very useful for rousing the clews and leeches up forward of the yard; while they also serve the purpose of *inner* halliards for the lower studding-sails, and are often employed as yard-arm jiggers in bending or as reef-tackles in reefing.

Topsail clew-jiggers. Like those for the courses. They are found very convenient in taking the clews well up above, and forward of the yard, greatly facilitating the operation of furling. Upper block hooks under the topmast trestle-trees, or to a strap fitted around the forward cross-tree, close in.

The lower blocks of clew-jiggers are secret and fitted with a pendant and sister-hooks. All clew-jiggers should be long enough to reach to the deck.

Fore and Main Buntlines. Usually rove double (*i.e.*, with *two* legs on *each* side), a double block hooked under the top and a *swivel*-block are used in reeving off each pair of legs. The swivel-block resembles a

fiddle-block in appearance, except that both shells are of equal size, and their ends connected by a swivel.

Reeve the standing part of the buntline through the upper sheave of its swivel-block, then take both ends of the standing parts through the sheaves of the block under the top, from *aft forward*, and toggle these ends, which are fitted with eyes, to toggles on the foot of the sail.

Through the lower sheave of the swivel-block is rove a whip, standing part made fast on deck, hauling part led through a sheave in the fife-rail.

Where there is but little drift between the top and the yard for the buntlines (and leechlines) there are fitted instead of blocks under the top a pair of double blocks on each side, hanging by the legs of a short pendant from a bolt in the forward part of the lower cap; sister-hooks in the bight of the pendant hooking to the bolt. The inside double block is for the buntlines, the outboard one is for the leechlines. Fig. 358.

Topsail Buntlines are single, and rove through the *lower* sheaves of fiddle-blocks* under the eyes of the

* *Upper* sheaves of fiddle-blocks at the fore for the jib and fore-topmast stay-sail halliards. At the main and mizzen for topsail bunt jigger and main and mizzen topmast staysail halliards, when rove.

topmast rigging, thence forward through the thimbles of lizards hitched around the neck of the tye-blocks and down to the foot-rope of the sail, to which they toggle-the hauling part leading to the deck through the lubber's-hole. They should be cut long enough to land the topsail on deck.

Topgallant Buntlines lead through the blocks under the eyes of the topgallant rigging and toggle to the foot of the sail, the hauling parts leading on deck.

They are sometimes fitted with two legs, one toggled to the foot, the other to the leech of the sail, so that when the sail is taken in, the leech is brought along the yard ready for furling.

Topgallant buntlines have lizards at the slings the same as topsail buntlines.

In small vessels there is but one buntline. It is spliced around a span, both ends of which are toggled to the foot of the sail.

BOWLINES.

Fore Bowlines. A single rope; the standing part made fast to the breech of a single block, hooked to a span between the fore-stays; the hauling end rove through the bull's-eye hung from the bowline bridle, back through the block at the stay. In tacking, &c., let go the *hauling* end, and re-reeve when on the other tack.

Main Bowlines consist of a whip and runner the latter reeving through the thimble in the bridle, and belayed to the fore fife-rail; and the former passing through a block in the end of the runner, led well forward-the standing part of the whip being secured to an eye-bolt at the fore fife-rail, and the reeving end over a pin.

In tacking, when it is required to let go the main bowline the standing part of the *runner* is cast off, and the whole shifted to the opposite side, ready for reeving.

Top-Bowlines. The *fore* toggle to the bridles, and lead forward through blocks hooked to the bees and back, inboard, to the forecastle. The *main* reeve through single blocks, connected to bolts in the after rim of the fore-top, and thence to the deck; and the *mizzen*, through the outer sheaves of the cross-jack brace-blocks on the main-mast.

DOWN-HAULS.

Jib and Flying-Jib Down-hauls, are each

bent to the head cringle of their respective sails, and after being rove through a few of the upper hanks, and a single block hooked to the bail (see TACKS) are led inboard. Jib down-haul *port* side, flying-jib *starboard* side.

Should the bail carry away, both the tack and down-haul blocks would be adrift; it is therefore safer to seize the blocks to their respective guys.

Topmast Staysail Down-haul. Rove same as above, comes inboard on the *port* side, down-haul block seized to the stay, or an eye-bolt in the bees.

Studding-sail Down-hauls. That for the *topmast* studding-sail is bent to the outer end of the yardarm and rove thence through a thimble on the leech, to the down-haul block at the tack, leading on deck, forward of the foresail, across the forecastle to the opposite side. That for the *topgallant* studding-sail is merely bent to the inner yard-arm of the sail, and led abaft all to the top.

Gail-topsail Down-haul (and Clewline) is led from the after clew of the sail (to which it is bent), through a single block at the head of the sail and thence through the hanks on the mast down to the deck.

OUT-HAULS.

Spanker Out-haul. Hooks to an eye in the shoulder-band on the boom, reeves through a block on the clew of the sail and through the sheave in the boom, belaying to a cleat on the boom.

Peak Out-haul consists of a whip and pendant. The latter is bent to the peak of the sail, rove through the sheave in the gaff, and at a distance equal to the length of the gaff, has a single block turned in, through which the whip is rove. The standing part of the whip is made fast under the top, the running part leads through a single block and thence on deck.

Lower Studding-sail Out-haul is connected by sister-hooks to the outer clew of the sail, and led through a single block (hooked to the boom with *clip* hooks) to a sheave above that for the guy in the bulwarks.

Gaff-topsail Out-haul is hitched to the clew of the sail, and rove through a sheave at the gaff-end, down to the deck, where it is belayed to a cleat on the boom.

Trysail Out-hauls. They are always single, and attached to the outer head-crinkle of the sail, being rove through a sheave in the gaff-end to a leader hooked under the top, and having a whip, which is led thence to the deck.

REEF TACKLES.

Topsail reef-tackles reeve up through the lubber's-hole, through the upper sheave of a sister-block in the eyes of the topmast rigging (or better, through a single block at the topmast cap), thence through a sheave in the topsail yardarm and a secret block on the leech of the topsail. The end of the standing part secures around the pacific-iron.

Sometimes the reef-tackles are fitted thus: The standing part is spliced to the strap of a bloc] shackled to the leech of the sail, below the close-reef bald, thence led upward through the forward sheave of a double block on the yardarm outside of all, down through the block on the leech, up to the remaining sheave of the double block, and so to the after sheave of the quarter-block, and lastly, through the lubber's-hole to the deck. In this case the quarter-block is three-fold, if there is no special block for the clewline.

Fore and Main Reef-pendants are hooked to the cringle and rove through a single block with lashing eyes, fitted to the yard just outside the lift. There is a thimble in the other end to which hooks the lower block of the clew-jigger, upper block being hooked at the cap.

Instead of these pendants regular lower reef-tackles are being fitted. These consist of a gun-tackle purchase, the lower block hooked to the reef-crinkle, upper block to an eye-bolt on the under forward part of the yard-arm. The hauling end leads to the deck through a block seized to the arm of the truss. These reef-tackles are cut long enough for yard-arm jiggers in bending sail.

LEECH-LINES.

These are confined to the courses and are clinched to the leech-*outer* one about one-third down from the head-earing cringle, and the inner one about two-thirds-and thence rove up through leading blocks on the bending jack-stay* to the inner and outer sheaves (respectively) of a double block hooked under the top, the hauling part of the leech-line reeving through fair leaders on the lower rigging to the *side* rack, on deck.

See also lead described under BUNTLINES. Fig. 358.

* These blocks should be so placed that the leech of the sails will be taut along the yard when hauled up,

and fitted with straps, which permit them to bang about a foot below the yard-a plan obviating the necessity of attending the leech-lines in bracing up. The hauling parts of the leech-lines, after passing through the double block are often rove through a large thimble or hank tailed to the lower part of the forward futtock-shroud. This keeps them from being jammed between the yard and the rigging when braced up.

153

NOTE. In large ships they are sometimes temporarily rove on the topsail-yards (through tail-blocks on the forward swifters) for furling sails, where the leeches are heavy.

BRAILS.

Spanker and Trysail Brails are middled, and the bights secured to their respective eyelet holes on the leech of the sail by cross-seizings, the ends rove through single blocks seized to the hanks on the trysail-mast.

In addition to the brails there is a *down-haul* for hauling the head of the sail down on the gaff, rove through a block hooked in the jaws of the gaff. On the opposite side, through a similar block, is rove a *clew rope* for taking the clew up toward the throat.

A Slab Line is sometimes used on the foresail. It is rove through a tail-block secured to the slings of the yard, *abaft*, and hanging down clear of the yard. The end is taken down abaft the sail and spliced around a span fitted with eyes, which toggle to the inner buntline toggles.

GUYS.

Lower Boom Guys. When double, the standing part of the *forward* one has an eye, seizing to the jib-guy just forward of the whisker, seizing to cross at every turn to make the eye lay flat. Rove thence through a single block on the boom, and back to a block with clip hooks at the bees, the hauling part leading inboard to the forecastle. When single, they connect to the boom by sister-hooks, and the block at the boom is omitted. The *after* guys are rove in the same manner, except abaft, to a bolt in the side and a sheave in the chess-tree, just forward of the gangway,

Spanker-boom Guys. *Vide* SHEETS.

BUNT-JIGGERS.

Bunt-jiggers are used for the topsails, courses and sometimes topgallant-sails. Courses and topgallant sails have single bunt-jiggers (or *bunt-whips*), topsails, a whip and pendant. The topsail bunt-jigger pendant for the *fore* leads through a single block lashed to the topmast-stay collar, close in to the trestle-tree. For the *main* and *mizzen* through the starboard and port upper sheaves, respectively, of the fiddle-blocks at the mast-heads. From the block the bunt-jigger leads down forward of the topsail, under the

foot, and hooks to the upper glut. The after end of the pendant has a single block (an iron-bound swivel) spliced in and a whip rove, *abaft all*, to the deck.

The bunt-jiggers of the courses lead in the same way, through a single block under the top. Rove single.

Topgallant bunt-jiggers lead in a similar way through a small iron block at the topgallant mast-head, and into the top.

In many vessels topsail bunt-jiggers* are led through a single block hooked to the eye-bolt in the heel of the topgallant-mast. This gives a better lead. When sending the mast up and down, the block is transferred to a small strap on the collar of the topmast-stay.

CHANGES IN THE LEAD OF RUNNING RIGGING.

The above list comprises the principal running rigging of men-of-war, together with the leads usually adopted. It sometimes happens that the lead of the gear on deck is modified for special reasons. For instance, in vessels with little quarter-deck space, the hauling part of the fore-brace is often led *aft*, and that of the fore-topsail brace, *forward*. The object is to have the foretopmen nearer to their own parts of the ship when bracing in to reef, and to keep them out of the way of the men on the main-topsail brace.

Lead of Gear about the Smoke-Stack. In making long passages under steam against a prevailing contrary wind, it is not unfrequent to see the lead of gear in the neighborhood of the smoke-stack, temporarily altered for the preservation of the rope. The hauling part of the fore topsail-brace and both parts of the fore-brace are brought down; the standing part of the fore-brace being hooked to a band on the mainmast ten or twelve feet above the deck, or to a launch's davit, if waist launches are carried.

Main-topsail-sheets are unrove from the quarter-blocks; gear about the mainmast is hauled up and covered with tarpaulins. All this takes little time to do, and in the event of a favoring slant, the gear can be readily rove off for making sail. The head braces have a fair lead when shifted as above described, and if a favoring breeze freshens, or seems likely to hold, preventer braces can be clapped on, and the regular ones shifted to their proper places aloft without shortening sail.

Temporary changes similar to the above are unobjectionable, in so far as they affect the lead aloft. But care

* The term *bunt-jigger* is preferred by many officers to the more correct word, *bunt-whip*. The latter is likely to cause confusion in hailing the men aloft, from the similarity of its sound to *bunt-line*.

155

should be taken not to alter leads about the deck except for good cause. So much of the handling of gear is done in the dark that the men may be confused, perhaps at a critical moment, if the position of any running rigging is frequently varied from that sanctioned by well-established custom.

CHAPTER X.

SAILS.

CANVAS is made of hemp, flax and cotton.

All canvas used in the navy for sails is flaxen, made in *cloths* of eighty yards in length, and in breadth of twenty inches. These cloths are rolled up in separate packages, called *bolts*. The stoutest canvas is No. 1; from this number it increases in fineness, and diminishes in strength, to No. 9 (see table in Appendix E).

In selecting canvas for sails, considerable practice and close observation are required. Besides the method detailed in the table of canvas, above mentioned, a good test is to bore a fid through the canvas, when, if bad, the threads are easily broken.

It is of importance that canvas should have a good and even selvage, and be free from tightness.

There is a great deal of difference in the stretching of canvas-that which is badly struck stretching most.

The principal sails of a ship are-the courses, or sails on the lower yards; the topsails, which are next in order above the courses, and the top-gallant sails, which are extended above the topsails.

For sails, see Plate 3, and corresponding reference numbers.

In all quadrilateral sails, the upper edge is called the *head*; the sides are called the *leeches*; and the bottom, or lower edge, is termed the *foot*. If the head is parallel to the foot, the lower corners are denominated *clews*, and the upper corners *head-earring cringles*.

In all triangular sails, and in those four-sided sails wherein the head is not parallel to the foot, the foremost corner at the foot is called the *tack*, and the after lower corner the *clew*; the forward corner of the head the *nock*, the after corner the *peak*, or head. The foremost edge (*or side*) is called the *fore-leech*, or *luff*, and the aftermost edge the *after-leech*.

Stay Sails. These are extended upon stays between the masts, taking their names from the stay on which they set. Those used in the navy are the fore-top-mast staysail, main-topmast and main-topgallant staysail and mizzen topmast staysail.

Studding Sails are set out beyond the leeches of

the foresail, topsail and topgallant sail, also beyond the main-topsail and topgallant sail, being known as the lower, topmast and topgallant studding-sails. Their upper edges are extended by studding-sail yards, the lower edges by booms rigged out beyond the extremities of the ship's yards. These sails are used only in favorable winds and moderate weather.

Additional Sails. Above the royals may be set sails called moonsails, sky-scrapers, &c. In the navy nothing is set above royals. In the merchant service rarely anything above a skysail. The sails usually set forward of the foremast are the fore-topmast staysail, jib and flying-jib. Some vessels carry outer-jibs, jib-of-jibs, or jib-topsails.

Storm-Sails are made of the strongest canvas, and are used, as the name indicates, only in the heaviest weather.

These consist of the *fore*, *main* and *mizzen* storm stay-sails and the "*storm-mizzen*." The storm-staysails

set on the respective lower-stays, or better, on a temporary storm-stay, toggled in the collar of the lower stay.

The storm mizzen is a triangular sail set abaft the mizzen-mast on a vertical "stay," hooked under the after trestle-tree, and set up on deck.

The fore and main trysails are also used in bad weather and frequently take the place of the main and mizzen storm-staysails.

The term *light sails* is generally understood in the service to apply to the topgallant sails, royals, flying-jib, and studding-sails.

Jibs are of great command with any side wind, but especially when the ship is close-hauled, or has the wind abeam; and their effect in casting the ship, or turning her head to leeward, is very powerful, and of great utility.

Although the yards on the foremast are termed *head-yards*, yet the fore-topmast-staysail and the jibs alone are known as the *head-sails*.

The *after-sails*, which are those that belong to the mainmast and mizzenmast, keep the ship to the wind; on which account ships sailing on a wind require a head-sail and an after-sail-one to counteract the other, so that the spanker being at one end of the lever, as it were, and the jibs at the other, they are of great assistance in steering and working a ship.

When a ship sails with a side wind, the clews of the fore and main courses are fastened by a tack and sheet, the tack being to windward and the sheet to leeward. The tack is, however, not in use with the wind aft, whereas the sail is never spread without the assistance of one or both of the sheets.

When on a wind, ships are said to have their *starboard*

(or port) *tacks aboard*, according to the side presented to the wind.

On the other hand, schooners have their *port* (or starboard) *sheets aft*.

When speaking of topsails, or such sails as are set by halliards, the altitude is termed *the hoist*, thus one topsail is said to have "more or less hoist" than another.

When speaking of courses the same idea is conveyed by the word *drop*, as one mainsail has "more or less drop" than another.

It is under the topsails that many important evolutions are made, and they are justly accounted the principal sails in a ship.

The draft of the ship and spars, Fig. 284, Plate 43, is of great service to the sail-maker, as well as to the boatswain, for by it he can measure for and cut out a suit of sails.

The sailmaker generally makes his own draft to work by.

Were a sail to be exactly square, there would be little art in cutting, but as a ship's sails are, mostly, anything but square, there is much skill required in the arrangement of every cloth. In cutting out and making them up, it is a primary object to adapt and cut the numerous gores* which, when brought together, will produce the ultimate form required, with the least possible waste of canvas. This is effected by casting the number of inches contained in each gore, so that when they are brought together they shall be equal to the number contained in the after leech-cloth. This is in reference to fore-and-aft sails, but the same theory applies in the parts of square sails.

Sails should *set as nearly flat as possible*.

The American schooner is an illustration, where even the jib is frequently laced down to a yard or boom, fitted for the purpose, in the desire to have everything set flat.

In pilot boats and yachts the sails are set as taut and as flat as the sacking-bottom of a bed. The utility of this plan was exemplified in the race between the yacht "America" and the English yacht squadron. Going free, there was not much difference; but on hauling up to make a stretch to windward the flat canvas of the "America" enabled her to distance her competitors.

The efficiency of the "America's" sails, as well as those of all of our small craft, is due to their *goreless*

shape, the canvas being cut as much as possible on the thread or woof, and also to the practice of lacing sails down taut to spars or booms. In Fig. 359, Plate 68, the foot of the sail is gored, and as it cannot be laced down, it bellies out to leeward, on a wind, and consequently much of the effect of the wind is. lost.

* In all sails those cloths which are cut in any direction except straight across with the thread or woof are said to be *gored*.

Plate 68

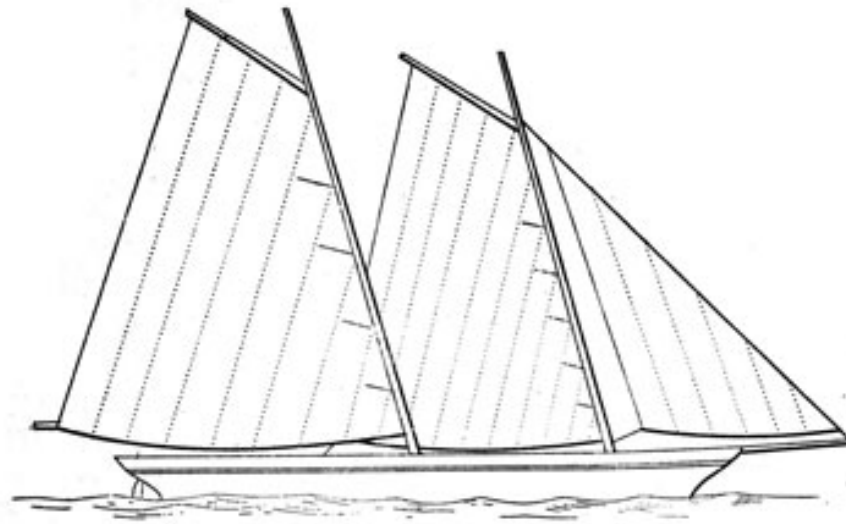


Fig.359

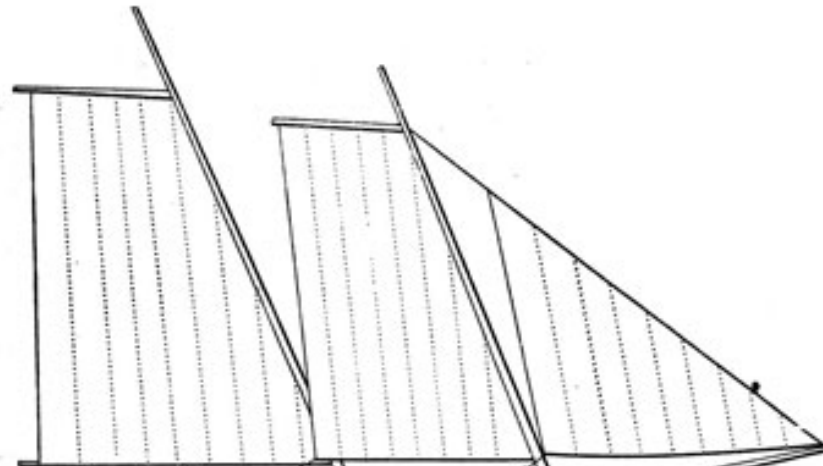




Fig.360

Fig.361



Fig.362



In Fig. 360, Plate 68, on the contrary, the only gore is at the mast to which the sail is attached; each cloth is pulled downwards bodily, and every single thread is stretched. There is, with this sail, but little concave surface, and therefore but little of the effective pressure of the wind is lost. The same principle applies to all sails.

Cutting out Sails. Sails are cut out cloth by cloth, the width being governed by the length of the yard, gaff, boom, or stay; the depth by the height of the mast. The width and depth being given, find the number of cloths the width requires, allowing for seams, tabling on leeches, and slack cloth; and in depth, allow for tabling on the head and foot. Sails cut square on the head and foot, with gores only on the leeches, as some topsails are, the cloths on the head between the leeches are cut square to the depth; and the gores on the leeches are found by dividing the depth of the sail by the number of cloths gored, which gives the length of each gore. The gore is set down from a square with the opposite selvage, and the canvas, being cut diagonally, the longest-gored side of one cloth makes the shortest side of the next; consequently, the first gore being known, the rest are cut by it.

In the leeches of topsails cut hollow, the upper gores are longer than the lower ones. By drawing on paper the gored side of the sail, and delineating the breadth of every cloth by a convenient scale of equal parts of an inch to a foot, the length of every gore may be found with precision.

The foot of square sails is *roached* so as not to be chafed by any boat, netting, or stay, that may stand in the line of their middle parts. Topsails are hollowed on their leeches, to avoid long yard-arms for the lower reef earings.

Sails are supplied to vessels complete, with points, earings, bowline-bridles, beackets, and robands. Their edges are tabled and stitched to the bolt-rope. The tabling of large sails is strengthened at the clews and foot by a third fold of canvas sewn in it. The tabling and clew-pieces are sewn on the after side of square, and on the port side of fore-and-aft sails.

Seams. Sails have a double flat seam, and should be sewed with the best American-made cotton twine of three to eight threads, and have from one hundred and eight to one hundred and sixteen stitches in every yard in length. It is the erroneous practice of some sailmakers not to sew the seams any farther than where the edge is creased down for the tabling; but all sails should be sewed quite home to the end, and, when finished, should be well rubbed down with a rubber. The twine for large sails used in the navy is waxed by hand, with genuine beeswax.

The seams of courses, topsails, lower staysails, trysails, and spanker, are 1 1/2 inches wide. After the larger sails have become somewhat worn, they are sometimes treble-seamed

down the middle of the seam, to strengthen them. Seams of other sails are 1 inch wide. One man can sew 100 yards in 9 1/2 hours, single seam.

Tablings. The tablings of sails are of a proportionate breadth to the size of the sail, and sewed at the edge with sixty-eight to seventy-two stitches in a yard.

Holes. Holes are made by an instrument called a stabber, and are fenced round by stitching the edge to a small grommet, made with a log or other line. When finished, they should be well stretched or rounded-up by a pricker or a marling-spike.

Sails have two holes in each cloth at the heads and reefs of courses, top-sails, and other square sails; one hole in every yard in the luff of flying-jibs; and one in every three-quarters of a yard in the lulls of other staysails.

Reef and head holes of sails have grommets of small line, worked round with stitches.

In order to strengthen sails, the boles in the heads and reefs should be placed thus: One hole to be made in the seam, another in the middle of the canvas, and so alternately; the holes in the seam to be half an inch lower than the hole in the middle of the canvas. By this, then strain would lie upon the holes in the seam, which are more capable of bearing it than the holes in the middle of the single canvas. It is likewise recommended to cut these holes with a hollow punch, instead of making them with a stabber or pricker.

Linings. Sails are strengthened with additional canvas at those places most exposed to strain and wear; in square sails, in the wake of cringles along the leeches on the foreside, called leech-lining, *c*, Figs. 363 and 364, in the wake of buntlines on the foreside, called buntline cloths, *g*; across the foreside, called reef and belly-bands, *a* and *b*; and in the case of topsails on the afterside, called the top-linings and mast-linings, *e* and *f*. Fore-and-aft sails are strengthened at the clews by pieces; and jibs sometimes with a strain-band. There is also the foot-lining *d*, reef-tackle-pieces *h*, and clew-pieces *i*.

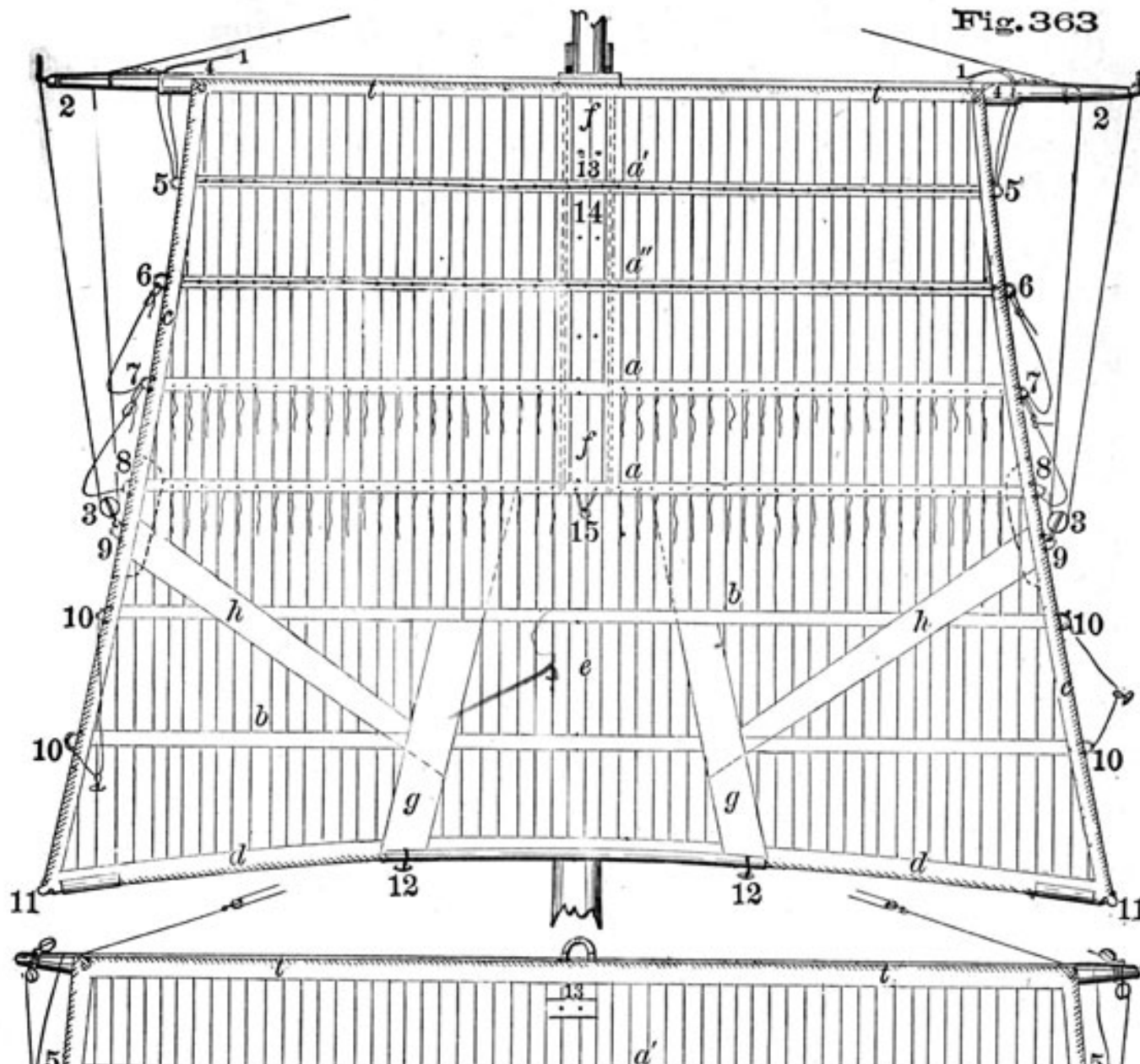
The clews of courses and topsails are formed of iron. The cringles for earings, reef-tackles, bowlines, &c., are formed of bolt-rope strands, worked round the leech-rope, through eyelet-holes in the tabling. The rope should be new, and half-an-inch smaller than the rope of the sail.

The reef-easing and reef-tackle cringles have galvanized thimbles.

Topsails have two bowline-cringles and one bridle on each leech. Bowline-cringles have no thimbles.

The reef-tackle cringles should be double instead of single, and connected by a stout span into which the reef-tackle hooks, Fig. 374, Plate 71. This distributes the heavy strain of the reef-tackle, and is much better than the present plan.

Plate 69



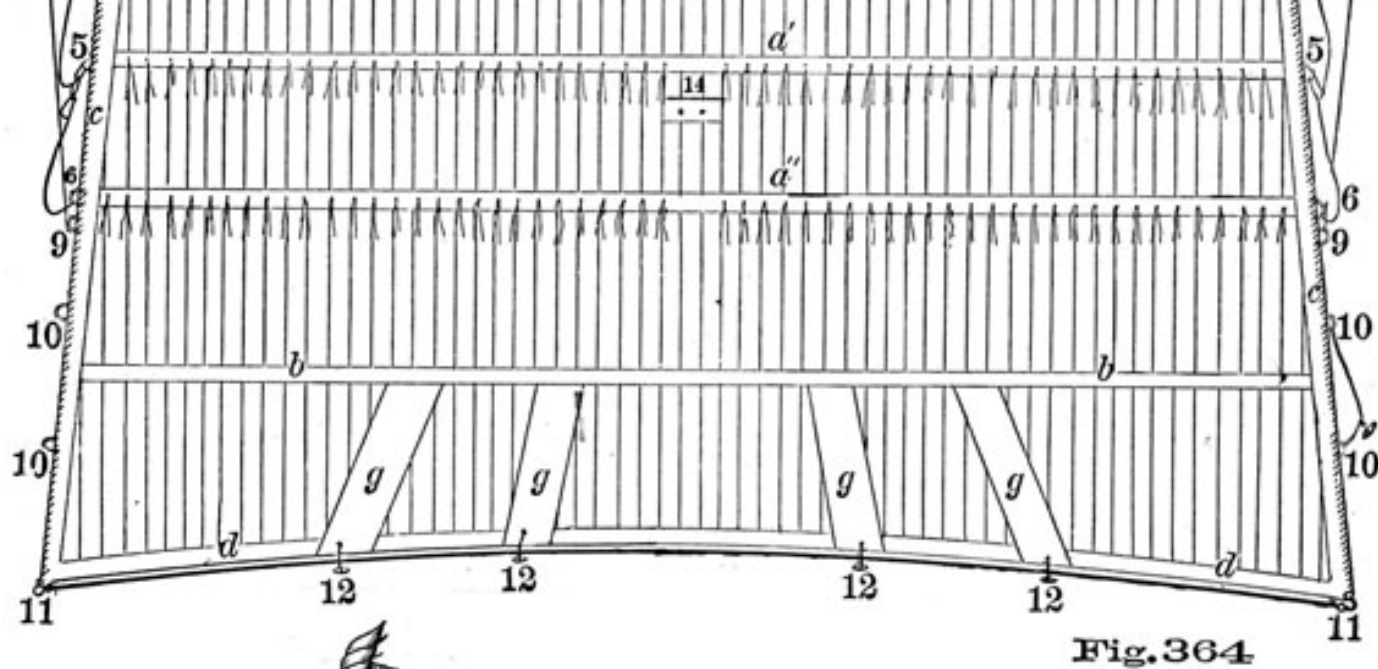


Fig. 364

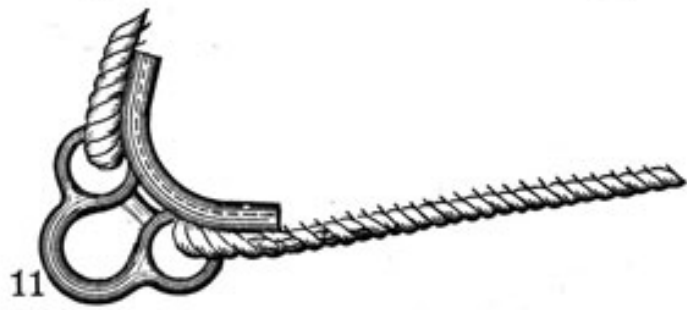


Plate 69, Fig. 363, represents a topsail bent to the iron jackstay of a topsail yard; *a' a''* are the first and second reef-bands, fitted to reef with becket and toggles on the yard; *a a* the third and fourth reef-bands with reef-points; *b b*, belly-bands-frequently there is but one; *c c*, leech linings; *d d*, foot lining or band; *e*, top lining; *f*, mast lining; *g*, buntline cloths; *h*, reef-tackle pieces or bands; *t t*, head tabling and head holes through which the robands are passed; all these, with the exception of the top, foot, and mast lining, are on the forward side of the sail.

The Gear. 1, the lift; 2, 3, reef-tackle; 4, head-earring; 5, 6, 7, 8, the first, second, third and fourth, or close-reef cringle-the earring is spliced into the eyelet-hole below the cringle, seized to it and bent to the cringle above; 9, reef-tackle cringle; 10, bowline cringles, bowline bridle and toggle for bowline; 11, iron clew or spectacle-to two of its eyes splice the leech and foot-rope, the eye and splice being leathered-to the third eye shackles the topsail sheet-block; 12, 12, buntline toggles, between which the foot-rope is

usually leathered; 13, 14, 15, gluts, the upper two abaft the sail and the lower one forward of the sail as shown in the figure.

Fig. 364 represents a course, also viewed from forward. The lettering and numbers of the details are the same as those for the topsail.

The clew of the course (11), viewed from forward, is shown in an enlarged form, leathered on flap forward between eyes of spectacle.

Generally speaking, topsails have three *gluts*, two abaft and one forward of the sail; the upper one is for the bunt-jigger to be used when furling sails. The second is for the same purpose when furling with a single reef, and the third, forward of the sail, is for a *midship buntline*, used for hauling up the slack of the sail in taking in the close reef.

Courses, Fig. 364, have two reef bands on the foreside, each being one-sixth the depth of the sail in the middle from the head; with a belly-band half way between the lower reef and the foot.

Topsails have three or four reef-bands, on the foreside, the lower of which is at half the depth of the sail, nearly; the belly-band, also on the foreside, is halfway between the lower reef and the foot.

Top-gallant sails may have one reef-band, though not pointed, as it is rarely ever used. A topmast studding-sail has one reef-band for setting with single reefed topsails. A lower studding-sail has a *rolling-reef*. None but the last are likely to be of much use.

Spankers have generally two reef-bands, one band running diagonally-termed a *balance-reef*.

Frequently the term balance-reef is applied to the close-reef

11

in fore and aft sails, particularly on board of "fore-and-afters."

The jib has a reef-band, and on fore-and-aft coasters a *bonnet* which is attached to the foot of the sail by means of a lacing. The *lug-foresail* of a schooner has a bonnet also.

The term *lug-foresail* is applied to that of the schooner, when the foresail hauls aft by a sheet, to distinguish it from a *boom-foresail* where the foot is laced down to a boom.

Roping. The bolt-rope sewed on the hollow or straight leeches of square sails, is put on with sufficiency of slack canvas to admit of that stretch of rope which arises from the constant strain upon the margin of such sails; and the necessary allowance for the stretch of the whole is made in the calculation of dimensions of such sails. But in the leeches of fore-and-aft-sails, as also in the round foot of spankers, jibs, &c., &c., a sufficient quantity of slack rope is introduced to keep the foot from curling up, to leave the after-leech of these sails free, and also to compensate for the amount of stretch which those parts of the sails above-named are constantly liable to.

Spankers are made with an allowance of stretch of 3 1/2 inches in each 3 feet of the foot, 1 1/2 in each 3 feet of the head, and 2 1/2 in each 3 feet of the length of the leech.

Sails are always bent to their yard or gaff with the roping next the spar, otherwise the stitches would be cut through by friction.

In square sails the rope is always sewn on the afterside; in fore-and-aft sails, generally on the port side. The roping of the foot is stoutest. tapering off to the leech-rope.

Courses are usually fitted with a double reef point forward of the sail, kept in place by a rope jackstay abaft, which is rove through the bights of the reef points, thrust through the eyelet-holes from forward aft.

Topsails are pointed by reeving one long point through the eyelet-hole, and stitching it in so that two-thirds will be abaft and one-third forward of the sail.

Topmast and Lower Studding-sails are reefed by passing temporary stops of spun-yarn through eyelet-holes.

Boom-mainsails and spanker are pointed by stitching the middle part of the points in holes "stabbed" in the seams of the sails. As in reefing, there is only slack sail to be tied up, heavy pointing is unnecessary.

French Reefs. The first and second reef bands of topsails in our service, and all reefs of square sails in the British and French navies, are now fitted with rope jack-stays instead of points, with reefing becket, Fig. 367, secured on the yard.

The jackstays on the sails are differently fitted. Our practice is to use two lines, weaving them in opposite

Plate 70

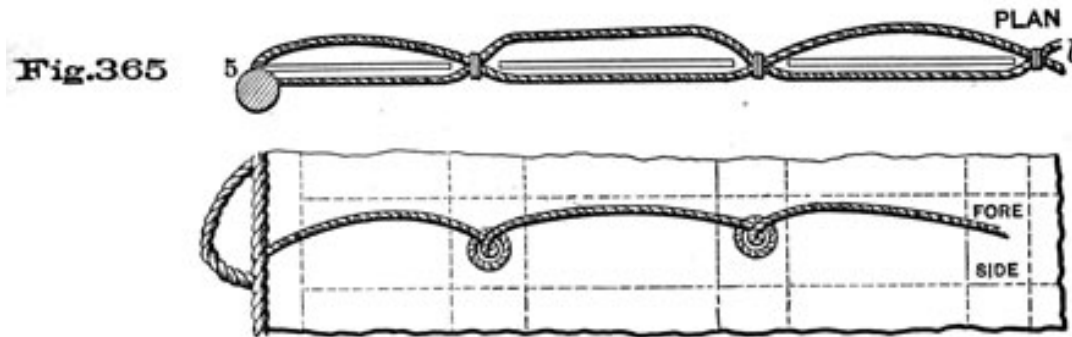


Fig.366



Fig.367

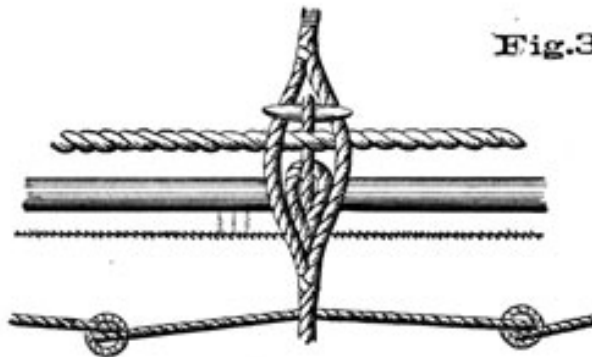


Fig.368





Fig.368



Fig.369



Fig.370



Fig.371

directions right across, in and out of the holes in the sail, stitching or seizing the crossings together, Fig. 365. The ends of the lines go through the reef-crangle holes and around the leech-rope with an eye-splice.

Sometimes the bights of the foremost line are shoved through the holes with a hard kink, the after line being rove through the kink, Fig. 366. Both plans are poor, and the same may be said of any arrangement involving an *after* jackstay for a topsail, as it is constantly liable to foul in hoisting.

The French plan dispenses with the rope jackstay abaft the sail. The eyelet-holes are placed in pairs, each eyelet of a pair being about two inches from the edge of a seam. The reef-line is secured by splice to the leech of the sail, passes forward of the sail to the first hole, reeves through that hole from forward aft, out through the second hole from aft forward, then in and out again as before, the two turns of the line being seized together abaft the sail with a fiat seizing. The line then passes twice through the next pair of eyelet-holes in the same way, Fig. 368. Another similar plan of fitting the reef-line, also French, is shown in Fig. 369. In this case the use of seizings is avoided, the bight of the reefing-line being shoved through the first

hole, the end taken in the second hole through a kink in the bight and out again, and so on to the next pair of holes.

FITTING AND BENDING, SAILS.

Prior to bending, the sails should be carefully examined, in order to supply any omissions, such as the points, bridles, thimbles, eyelets, and gluts. In addition to which, the fore and aft sails must be prepared with hanks, brail-blocks, lacings and lashings, and the square sails with earings and "rope-bands," or robands.

Head-Earings. Small manilla rope, one end spliced into the head-earring cringle. the other end whipped. It is cut long enough for two turns from the staple to the head-earring cringle, with end enough for several turns through the backer.

Reef-Earings. Similar to the above, but of heavier stuff; one end spliced into the *reef-crinkle eyelet*, just below their respective thimbles; the other end whipped. Length sufficient to haul out to and around the proper cleat on the yard, with end enough to expend around the yard and through the reef-crinkle for three or more turns.

Bull-Earings. The simplest and best are of well-worn manilla, with one end spliced into the standing part, Fig. 370, forming a bight long enough to hitch around the

yard outside the proper cleat, and reeve through the reef-crinkle and back to the yard.

These are called *bull-earings*, and remain on the yard instead of in their cringles, that for the first reef being rove through its cringle and brought back to the yard ready for use.

Bull-earings have been made (of smaller stuff) to give more parts in the first turn by splicing on an additional length in the first bight, as in Fig. 371, but they twist up in wet weather, and are otherwise objectionable as compared to the simple form.

Robands, consisting of two-yarn foxes, are middled, and secured to the head rope, by thrusting *one* end through the bight, which is first passed through the eyelet from the *fore* side of the sail, and hauled taut.

Gaskets. These are classed as bunt, yard-arm, and sea-gaskets; the first two made of plaited yarns. Those for the *bunt* consist of two single legs-one on each side of the slings, varying from two to three inches in width, and fitted with a thimble in one end, by which it is secured to the *bending* jack-stay with a permanent seizing-the other extremity having a laniard, which is hitched to the opposite quarter of the yard on top; the gaskets crossing each other on the bunt when the sail is furled. The *yard-arm* gaskets are made of sennit also, and fitted with a thimble, or eye, in one end, and the other tapering, and secured at equal distances (generally about every third seam) along the yard, *underneath* the jack-stay, by a cross-seizing just below the thimble. The gasket lies under the head of the sail. When furling it is taken up forward and over, and the end rove through the thimble, the sail tossed well up and the end expended around its own part.

In making harbor gaskets, the broad part should be long enough to take the sail in when furled with two reefs; they should be carefully blacked, and to avoid staining the sail, should be lined.

The *sea-gaskets*, or more properly furling lines (of which there are two on each of the lower and topsail yardarms), may be either of sennit or small-sized rope, and of sufficient length to go around booms and all, when furling in heavy weather. These, however, are not necessarily permanent fixtures to the yard, although usually put round it at the outer and inner quarters with a running eye, and the surplus end bighted up with frapping turns, and thrown forward of the sail, at sea. They are removed in port.

BENDING SAILS.

The minutiae of bending sails "made up for stowage," is given below. It must be borne in mind, however, that the

best authorities recommend that square sails should be made up "as furled" for bending.

A description of the latter-mode of bending sail will be found under the head of PORT DRILLS.

BENDING COURSES.

Making-up for Bending. In making up a course for bending, stretch the head of the sail taut along the deck, having the *roping* on the *under side*, bring up to the head the belly-band, then the foot, leaving the clews out at each end, also the bowline-bridles, and roll taut up; pass the head-earring around the sail close inside the leech-rope, and put a stop of good spun-yarn to every seam. The reef-earings are made up in the sail. The *head* and *foot* are both left out for bending the gear.

To Bend. Toggle the buntlines to the foot-rope at each side of the midship-seam, and clinch the leech-lines to their cringles, stopping both to the head of the sail-the former to the eyelet of the middle roband. and the latter in the wake of their leading-blocks. Hook the yard-arm. jiggers (usually the clew-jiggers)* from straps around the pacific-iron to the first reef-cringles. Hook on the clew-garnet blocks to the after part, passing them *under* the sail.

Stop the head-earring along the head of the sail towards the bunt.

Send hands on the lower yards, trice up the booms, man the gear and sway aloft, merely gathering up the slack of the clew-garnets. When high enough (i.e., when the centre of the sail reaches the centre of the yard), "bring to," cut the buntline and leech-line stops, and make fast the midship stop, together with three or four robands at each side of it, by passing the short ends *under* the jack-stay from *forward aft*, and the long ones *over* and *under*, from *aft* forward-thence back through the eyelets, and square knot them on top. Carry out the head-earings and haul the sail out until the head-rope is taut along the yard. Pass two turns of the head-earring through its eye-bolt, or thimble of a head-earring strap. Expend the end through the backer, from the head of the sail up forward into the thimble of the backer, down through the backer and up again through the cringle, hauling the cringle up snug at each turn. Hitch the end through the hauling-out parts. Fig. 372.

* Where reef-tackles are fitted to the courses the clew-jiggers may be dispensed with, and the sail hauled out to the yard-arms by the reef-tackles, the head-earring cringle stopped to the standing part. This plan, apart from the facility it affords in reefing, will be found serviceable in bending the sail.

In bending as above stated, if the course is a large one, time will be saved by sending it up loosed, or at least with the greater part of the sail hauled into the bunt. If made up, the weight on the yard-arms will be so great, when the sail is rolled up as described, that it will tend to hang below the yard and be troublesome to haul up.

FURLING COURSES.

The Leeches are handed in along the yard, then the sail rolled up snug, with the ends of the points passed in towards the bunt, to give the sail a gradual increase in that direction. Pass the gaskets square, lower the booms, and if required stop up the gear. The buntlines and leech-lines are stopped to the slings close down, and hauled taut on deck. The bowline-bridles of all sails in furling are laid with the toggle towards the bunt, and bridles taut along the yard.

When a sail is neatly furled, it appears neither above, nor below the yard-earings well slewed up-sail smooth under the gaskets, bunt square, and a *taut* skin. The heels of the booms should be square, and everything necessary completed, previous to *squaring* the yards.

BENDING A TOPSAIL.

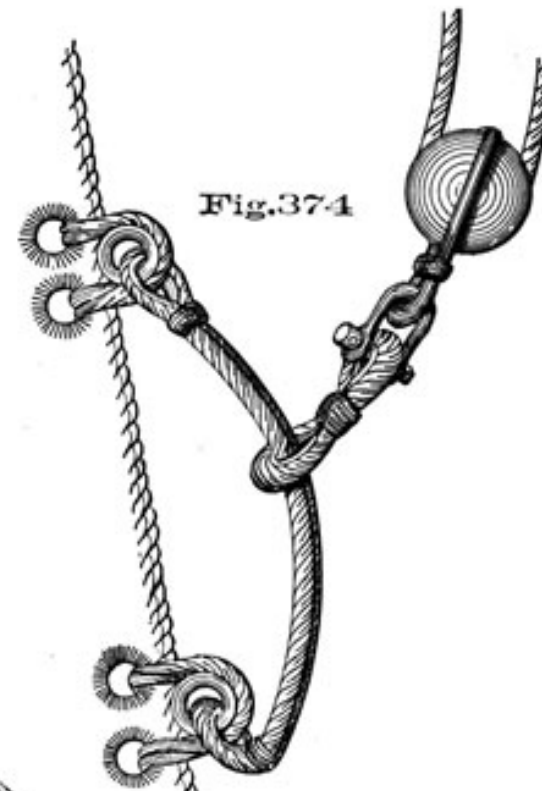
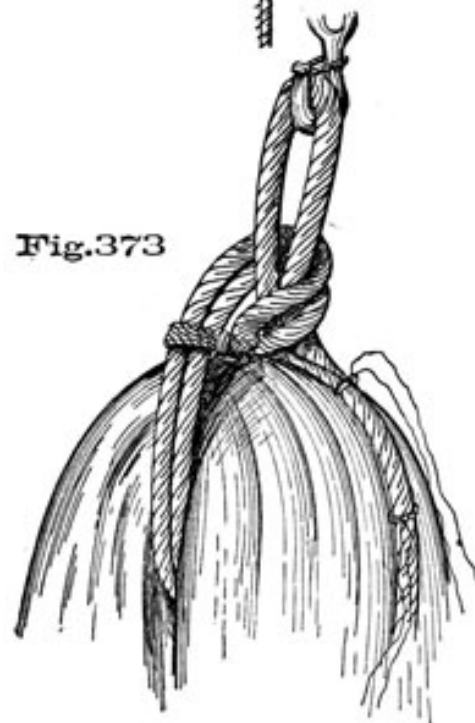
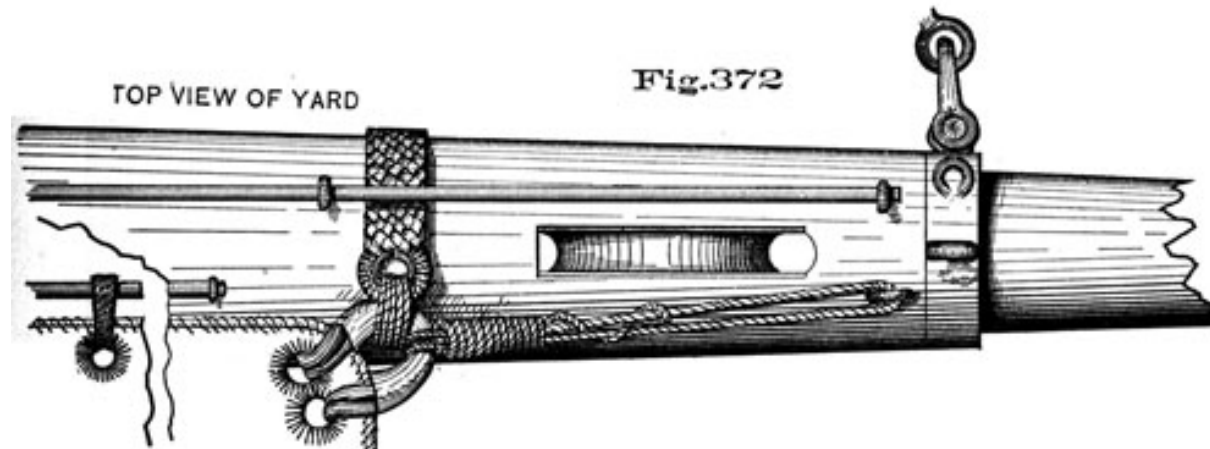
Having prepared the sails for bending, and supplied deficiencies, get them on deck and roll up on the *fore* part,* as follows:

To make up a Topsail, stretch the head of the sail taut along, after side down; bring the second reef up to the head, and lay all the points and earings snugly along; then bring up the belly-band, and then the foot. The clews, bowline-bridles, and reef-tackle cringles, should be left out, so that when the sail is sent aloft for bending, the sheets, reef-tackles, and bowlines can be bent without loosing the sail, which will be found of great advantage when blowing fresh. Roll well up, stop with spun-yarn at each seam, and expend the head-earings round the ends of the sail.

To Bend. Hook the sail-tackle to a strap at the crotch of the topmast-stay, and to *one* bight of a stout pair of slings, passed around the centre of the sail. *Seize* the other bight to its own part around the standing part, as in Fig. 373. For exercising, a better form of strap is shown in Fig. 375. Hook yard-arm-jiggers, for hauling out the head

* The reason for making the sail up on the fore part is to cause it to fall *forward*, and clear of the top, when cast loose from the slings.

Plate 71






Fig. 375



Fig. 376

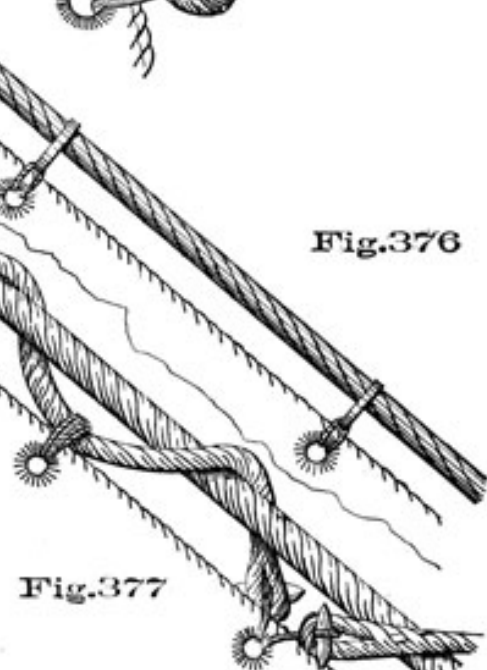


Fig. 377

of the sail, if the reef-tackles are inadequate.* Overhaul the sheets and reef-tackles, bringing the bending ends of both into the top, and have the bowlines, buntlines, and clewlines ready for toggling, and bending to the sail. Send hands aloft on the yards, man the tackle, trice up the booms, and "sway aloft." When the sail rises above the top, cut the stops; hook or shackle the sheets and reef-tackles, passing the head earing aloft to the yard. Hook also the clewlines (or if double, hook their blocks) to the clews, and toggle the buntlines and bowlines to the foot-rope and bridles respectively. Now haul out on the yardarm-jiggers and lower on the sail-tackle until the head of the sail is stretched along the yard and its centre comes flush with the centre of the yard, then pass the midship stop, rouse out the head-earings, cutting the seizings of the slings around the sail; at the same time gathering up the slack of the buntlines and clewlines. Pass the earings, Fig. 372, and the remaining robands, as in the case previously stated. Then unhook the sail-tackle from the stay, overhaul the gear, sheet home, down booms, and hoist the sail up to a taut leech; after which, lower the topsail, clew up, and furl.

It is better to toggle the buntlines before swaying the sail aloft.

When the sail is nearly rolled up, hook the bunt-jigger, bouse it well up, lower away roundly the buntlines, and *shove* the sail well into the skin, taking pains to keep the bunt square; pass and secure the

gaskets, lower and square the studding-sail booms.

If the bunt-jigger is *hooked* into the upper glut and *stopped* to the second one, it will draw up a neat skin to cover the bunt.

HEAD SAILS.

These sails require some fittings not strictly within the sailmaker's department, such as the bails for tack-lashings, the *hanks*, &c.

Hanks are stout thimbles, of the shape shown in Figs. 361 and 362, which traverse up and down the stay. The common plan is to attach them to the luff by foxes of spun-yarn rove through the eyes of the hank and the eyelet on the sail. A neater plan is suggested by Fig. 362, where a toggle is strapped into one eye of the hank, with a double strap of 6-thread stuff, and hooks into a single strap worked on the opposite eye, of 9-thread.

Fore-and-aft sails running upon hemp stays are bent with

* On board of the practice ships, in lieu of the reef-burtons and pendant which was the old plan, the sail is hauled out by the reef-tackles alone. And whenever the lead permits, reef-tackles are used as yard-arm-jiggers.

168

manilla bridles, the bridles being toggled to the sails. Those running on iron stays are fitted with hanks, Figs. 376 and 377. Bridles must be passed *against* the lay of the stay.

To bend a Head Sail. Make it up on the foot, laying the sail down in bights; see the head, tack and clew-cringles clear. Pass a strap around the body of the sail, into which hook the halliards. The down-haul is rove and bent to the sail-strap. By means of the down-haul and halliards rouse the sail out on the boom and bend it to the hanks, hooking the halliards and down-haul to their places in the head and swaying up, when necessary. Begin bending to the *upper* hanks and work down toward the foot; hooking the tack to the bail, or strap (fore-topmast stay-sail). Shackle the sheets, take off the sail-strap when of no further use.

To stow a Head Sail. Haul it close down and pass the gaskets, have a clew-stop on the clew of the jib to hold the clew forward of the cap, and a similar one from the flying-jib clew to the wythe. The cover is

then placed over and the stops tied. Jib-sheets stopped down and the sheets and halliards hauled taut. The fore-topmast stay-sail stows in a netting or canvas bottom made for the purpose and placed on the bowsprit between the stays.

Furling lines or sea gaskets are used in stowing the jibs at sea; for port there is fitted on the boom a *centipede*, a piece of sennit running the length of the boom, with short pieces of the same material running athwartship at certain intervals. The sail stows on the centipede, and the short ends are brought over and tied on top, as gaskets. Jibs *carefully* stowed in their own cloths may be made to look as neat as with a regular cover on, but require more care in stowing than any other fore-and-aft sail.

The flying-jib should be sent out for bending on the *starboard* side, on account of the boom being on that side of the bowsprit.

Make up a head sail, for stowing away, on the after leech, doubling the tack and head clew in toward the sheet before commencing to roll up.

Royals and Top-gallant Sails. They should be always bent on deck, on account of the difficulty of hauling out by hand; the earings and rope-bands are passed like those for the courses and topsails; the buntlines, clewlines, and sheets, being bent after the yard is crossed. If, however, it should be necessary to bend the *top-gallant sail* aloft, it may be sent up by the royal yard-rope, and the head-cringles hauled out by means of the top-gallant studding-sail halliards.

NOTE. In furling either a royal or top-gallant sail, it should be rolled up with a *long, taut bunt*, and the clews "tucked in," to avoid tearing the sail in its upward or downward passage.

BENDING FORE AND AFT SAILS.

The heads of the trysails and spanker are made to traverse on gaffs. To bend:

First Method. Lower the gaff, bight the sail down on the foot, keeping head and luff clear for bending. Reeve the brails (*throat, middle and foot*) through their blocks, passing the sail through their bights, which are seized to the leech of the sail at the proper eyelet-holes. Bend the head out-haul and secure the head to the hoops, beginning with the hoops nearest the peak. Rouse up and secure the *nock* or throat earing, which is passed around the gaff and through its cringle, or secure the cringle by an iron staple, both ends of which are then shoved up through holes in the jaws of the gaff and keyed on top. Bend the head down-haul and clew-rope. Sway up the gaff, seizing the luff of the sail to the travelers on the batten, or to the hoops on the trysail-mast, as the case may be; finally, pass the tack lashing. If the sail is a spanker, hook the out-haul block to the clew. Trysail sheets are not usually hooked until just before setting the sail.

Second Method. Keep fast the gaff. Send down a whip from under the top and bend it to a strap around the head of the sail. Trice up the head, stopping the luff to the hoops on the trysail-mast as the sail goes aloft. When high enough pass the throat lashing, bend the head out-haul and down-haul, haul out the head, bending it to the hoops on the gaff as it goes out.

Furling Fore and Aft Sails. They are furled best with a cover, but can be furled in the two after-cloths, though not usually looking so well. In furling with a cover, brail the sail close up and stop the cover around, commencing at the jaws and working down.

BOOM-MAINSAIL.

The routine, as stated in the preceding articles, will be found to answer for this sail, there being, however, necessarily some slight exceptions, viz.: the omission of brails; and in lieu of an out-haul the clew is shackled to a span on the boom. Another distinction is, that the foot of the sail is stopped down taut to the boom by means of points or stops fitted for the purpose.

STUDDING-SAILS.

In bending these sails, place the roping of the sail on the

after and *under* side of the yard, secured in such manner as to preclude the possibility of its bagging down.

The outer earings, which are spliced into the cringles with a short eye, are passed through holes bored in the extremities of the yard, from the after side-thence back. through the cringle and over the yard, *inside* of the hole, until three or four turns are taken, when the end is hitched through the cringle and around the single part. The sail is then brought taut along the yard, the inner earing passed in the same manner, and the head-rope secured to the yard by neat sennit stops, which are fixtures in the eyelets. Lastly, the sheets and down-haul are bent as described in RUNNING RIGGING.

To Make up Topmast Studding-Sails when not Bent. Stretch the sail taut along, and overhaul the down-haul through the thimble and block, and bight it along the whole length of the leech. Then roll up toward the inner leech, lay the sheets along the whole length of the sail, roll up over all, and stop the sail well up with rope-yarn. The earings are expended round the head of the sail. The topgallant studding-sail is made up in the same manner.

When Bent. In making up a topmast studding-sail, when bent, overhaul the down-haul the length of the lull or outer leech; then take the foot up to the yard, and place the tack-cringles out. Bight the down-haul along the yard, also the sheets; roll the sail snugly up and stop it with sennit-tails. These are clove-hitched around the studdingsail-yard, and remain there. When the sail is being prepared for going aloft the sennit stops are cast adrift from around the sail, and the latter held together by a rope strap and toggle, as will be described hereafter under MAKING SAIL.

Lower Studding-Sails are bent and made up in the same manner as topmast studding-sails, with the sheet in.

When ready for sea, topgallant studding-sails are kept in the tops with covers on.

The other studding sails are rolled up in their covers and stowed on the booms.

It is the practice to keep, while at sea, the topmast studding-sail up and down the fore rigging, the topgallant studding-sail in the topmast rigging, and the lower studding-sails triced up and down the foremast. This is a very good plan when circumstances render a frequent use of these sails liable.

All spare sails should be *tallied* before being stowed in the sail-room, as it will prevent mistakes; and if a sail is properly stowed, and the sail-maker takes a list when they are stowing, there can never be any difficulty in finding what may be wanted.

Sail-Covers. for fore-and-aft sails, and for square-sails of steamers, very frequently have imitation gaskets, stitched or painted on the outside, which adds much to their appearance.

In addition to the cover for the main-sail and main-topsail, steamers have a "jacket" which laces around the main-mast to protect it from the smoke of the funnel.

Back-Cloths. These are for stowing the bunt of the topsails in. They are made of stout canvas, roped around, and are attached to the after part of the yard close up to the topmast. When arranged for furling, one corner is stopped out to the forward swifter of the topmast rigging, to the topsail-lift, or wherever convenient. They add very much to the neat appearance of the sail when furled.

They should be sent down when the sails are unbent.

An examination of this partial table of allowance of sails for vessels of the "Trenton" class, will give a good idea of the different numbers of canvas used and the various sizes of roping. All the sails allowed are not included in this table:

SAILS FOR A VESSEL OF THE "TRENTON" CLASS.

Sails	No. of Sails	No. of Canvas	Size of Rope			
			Head	Foot	Leech	Hoist
Fore-sails*	2	2	2 1/2	5 3/4	5 3/4	-
Fore-topsails	2	2	2 1/2	5 3/4	4 1/2	-
Fore-topgallant-sails	2	4	2	3 1/4	2 3/4	-
Fore-royals	2	8	1 3/4	2 1/2	2 1/2	-
Main-sails	2	2	2 1/2	5 1/2	5 1/2	-
Main-topsails	2	2	2 1/2	5 3/4	4 3/4	-
Main-topgallant-sails	2	4	2	3 1/4	2 3/4	-
Main-royals	2	8	1 3/4	2 1/2	2 1/2	-

Mizzen-topsails	2	3	2 1/4	4 1/2	3 1/4	-
Mizzen-topgallant-sails	2	6	1 3/4	3	2 1/2	-
Mizzen-royals	2	9	1 1/2	2 1/4	2 1/4	-
Flying-jibs	2	5	-	2 3/4	2 3/4	2 3/4
Jibs	2	2	-	3 1/2	3 1/2	3 1/2
Fore-trysails	1	1	2 1/2	3	3 3/4	3
Main-trysails	2	1	2 1/2	3	3 3/4	3
Storm-mizzens	1	1	-	3 1/4	3 1/4	3 1/4
Spankers	2	2	2 1/2	3	3 3/4	3
Fore storm-staysails	1	1	-	3 1/4	3 1/4	3 1/4
Fore-topmast staysails	2	2	-	3 1/4	3 1/4	3 1/4
Mizzen storm-staysails	1	1	-	3 1/4	3 1/4	3 1/4

* One fore-sail, one fore and one main-topsail to be of No. 1 canvas.

172

All sails are made of flax canvas; cotton canvas is used for the following purposes:

No. 1 is principally for the construction of water-tanks for boats.

No. 2 for mess-cloths.

No. 3 for making tarpaulins and head-cloths.

No. 4 for deck awnings, boom-covers, hammock-cloths, &c.

Nos. 5 and 6 for wind-sails, sail-covers and boat-covers. Nos. 7 and 8 for boat awnings, awning curtains, wheel-covers, &c.

Nos. 9 and 10 for binnacle-covers, side-screens, &c. Hammock stuff for making hammocks.

Bag-stuff for clothes-bags, hatch-hoods, &c.

Cot stuff for cots.

NOTE. All fore and aft sails, as well as courses, topsails and topgallant sails, are finished with iron clews.

See also Appendix E.



[Previous Part](#)



[Seamanship](#)
[Home Page](#)



[Next Part](#)

Copyright (C) 2006 [Historic Naval Ships Association](#)

All Rights Reserved

[Legal Notices and Privacy Policy](#)

Version 1.00, 24 Apr 06

PURCHASING WEIGHTS.

IN addition to the gear described in previous chapters for handling sails and spars, there are certain purchases specially rigged on ship-board, when required, to hoist weights in or out of the vessel, or to transport such weights from one part of the ship to another.

The support for these purchases may be-

First. The lower yard alone, supported by its lift.

Second. The lower yards, supported themselves by purchases from the mast-heads.

Third. The mast alone, as in the case of mast-head pendant tackles.

Fourth. The lower yard supported from the mast-head and by a derrick.

Fifth. The derrick alone.

Sixth. The sheers, already described under MASTING.

Hoisting in Light Articles. To hoist in an object of no great weight, such as a barrel of flour, use two single whips, one from the yard-arm, the other from the collar of the lower stay. The ends of the whips secure to a strap around the barrel, and by walking away with the yard-whip, the barrel is raised from the lighter alongside above the level of the rail; clap on to the stay whip, easing away the yard until the barrel is in line with the hatch, and strike it below by the stay-whip.

For a heavier weight use, instead of the single whips, the *yard and stay water-whips*, Fig. 267, Plate 35, described under TACKLES. See that the lower lift is taut, and hook the upper block of the yard so as to plumb the lighter.

It is desirable in port to keep the quarter-deck clear, therefore lead the yard-tackle forward on the same side as the weight is being raised, and the stay forward on the opposite side.

When using the "yard and stay," to provision or water ship, it will be found very advantageous to use a small single whip, or tricing-line, to light over the lower block of the tackle, to the great saving of paint work; the coamings of hatches should be carefully protected from injury by mats or boards.

In provisioning ship with the main "yard and stay" (water-whips) the fore-topmen break out, make up and stow the stay-tackle, and the main-topmen the yard tackle.

Hoisting Heavy Weights. In hoisting a heavy object, with purchases from the yards, it is important that the latter should be well secured, so that the yard may not be sprung or rigging endangered.

To Support the Lower Yards. Use in addition to the lift one or both top burtons, whose upper blocks are hooked into the top-pendants. It is the common practice to hook the burton of the side to the eyebolt in the burton strap on the yard, and the burton from the opposite side to a temporary strap around the yard. It would be safer when the weight is so great as to require the use of both burtons to have temporary straps for each of them near the point from which the weight is suspended, unless the regular burton strap happens to be close to that point, in which case it is of course used. Our general rule should be in supporting a lower yard or derrick, to attach the supporting tackles and guys to the yard or spar *at the point from which the weight is to hang*.

If both yards are to be used together, as in hoisting out boats, the main-yard will probably require bracing *up*, and the fore-yard bracing *in*. Any bracing required should be done first and then the yard topped up on the side used, if necessary, slacking the opposite lift.

After these preparations, haul taut the opposite lift first, then see that the weather lift and burtons bear an equal strain.

When the yard has been left square, or been braced *forward*, the burton from the opposite side is taken across forward of the mast. When a yard has been braced *in*, the supporting burton from the opposite side leads best abaft the topmast and between the topmast rigging and back-stays.

Hoisting in Spare Spars. Very heavy topmasts may require the use of both fore and main yard and stay tackles, but usually the main yard tackle alone will be sufficient. Fig. 377, Plate 72.

Support the main yard by both top-burtons, get an equal strain on lifts and burtons. Send down a clew jigger hooked to the main lift, and sway up and hook the upper block of the yard tackle. This block has fitted to it a strap which is rove through the thimble of the block and stopped to the back of the hook as in Fig. 2G7. The strap goes around the yard, and the hook of the block hooks into its bight.

The lower block of the yard tackle is hooked to a lashing on the balancing point of the topmast, the lashing steadied by backlashings from head and heel of the topmast. Hook the fore top-burton to a strap around the head of the topmast, and a spare burton from the main topmast head to a strap through the fid-hole, hoist the spar on board by the yard, guying it forward or aft by the top-burtons.

Hoist in other heavy spars in the same way, hoisting in

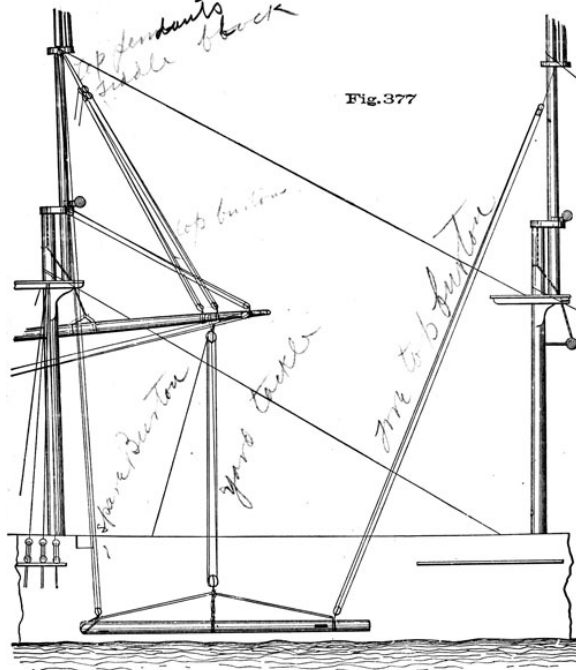


Fig. 377

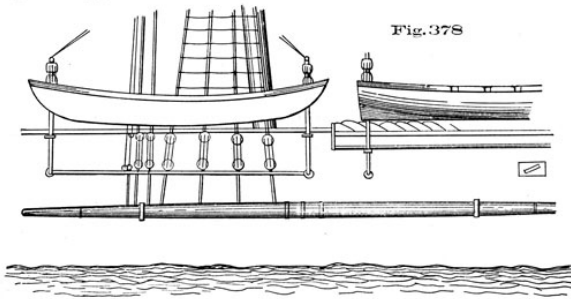


Fig. 378

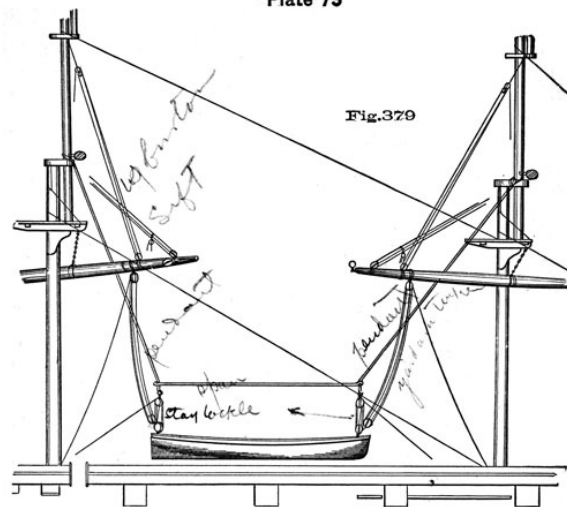
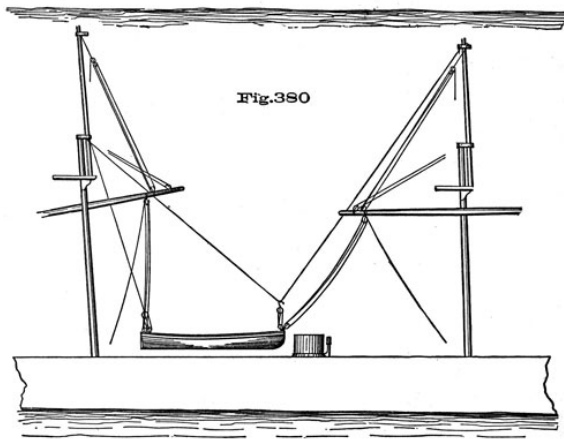


Fig. 379



175

first such as are stowed underneath. See, when hooking on, that the spar has the same fore-and-aft direction as it is to take when stowed, for it would be difficult to slue it when landed inboard.

Lighter spars can be hoisted in with the water-whips, Fig. 267, Plate 35.

Few ships carry anything like a full complement of spare spars. Such as they have are usually stowed between the fore and main mast.

Stowing Booms. It is impracticable in most steamers to stow the spars amidships, on account of the smoke-stacks, although room is gained in that way. If stowed in two piles, the spars on the starboard side are spare spars for the main and mizzen, and those on the port side for the fore, and spare head-booms.

Spare topmasts stow with their heads forward and always outside the boats.

If sufficiently numerous to cause confusion, spare spars should be *numbered on each end*, and a list taken, which will save time in finding any spar that is wanted.

The booms are lashed to span-shackles, put in the deck for the purpose. When stowed they (and the boom-boats) are protected by a tarpaulin boom-cover.

Some vessels stow spare topsail-yards in *lumber-irons*, or cranes on the quarters, Fig. 378, the main on the starboard side, fore on the port. To get them into the cranes from alongside, use the boats' falls with assistance of burtons from the main and mizzen topmast heads. Support the davit heads.

To hoist a yard on board from the cranes, if in port, lower it into the water with the boats' falls, and hoist in inboard with the main-yard tackle. If at sea, brace in the main-yard as much as possible, use the tackles described in getting in a topmast, and ease the yard clear of the irons with tackles from the main and mizzen rigging. Have steadying lines to control the yard.

Spare spars should be protected from the weather by having all cracks chined with cotton, and filled up with white lead, and the yards painted and covered, if in the chains, in the wake of chafes.

The spars in the chains frequently foul the mainsheet, therefore there should be no lack of timenoguys on them.

Hoisting in and out Boats. One of the-most frequent operations in hoisting heavy weights with the assistance of the lower yards, is getting in and out boom-boats with the yard-tackles, triatic-stay and stay-tackles, Fig. 379.

The Triatic-stay consists of three parts-two pendants, and span. The pendants have hooks in their upper ends, which hook to bolts in the lower caps (fore and

main), or are secured around the mast-head. In the lower ends of these pendants are spliced thimbles, into which the stay-tackles hook. These pendants are spanned together by another rope, the ends of which span are spliced around thimbles which traverse on the pendants. The length of the span will be the distance you wish to have your pendants apart, viz. the length of the launch.

On long vessels, where the boats stow *abaft* the smokestack, the forward stay goes to the fore-topmast head, and the span from the lower end of the stay to the main cap. The main-stay hangs, as before, from the main cap. Fig. 380.

Hoisting in Boom-boats. The order will be given: IN BOATS! the crew prepare for their duties as follows:

In the launch-coxswain, assisted by some of the boat's crew to pass out oars and sails, hook purchases, &c.; or, if a steam launch, to hook on the main-yard and stay to the boiler, which is often hoisted on board first and placed in the gangway, to be afterwards hoisted in the boat when inboard.

On deck-fore and main-topmen clear away the booms for the reception of the boats.

Aloft-Forecastle-men take out their clew-jigger on fore-yard, are responsible for the fore-yard tackle, and hook the burton or burtons on the fore-yard.

Fore-topmen overhaul down their burtons, sending the falls on deck; send down fore-topsail clew-jigger for fore-triatic, and look out for fore-stay tackle.

Quarter-gunners look out for main-yard tackle, getting main clew-jigger on main-lift.

Main-topmen send down main-topsail clew-jigger for triatic-stay, overhaul down burton, and look out for mainstay tackle.

Mast-men are responsible for leading-blocks.

NOTE. A small, strap is seized on each triatic-stay pendant well below the hook. Into this becket hook the clew-jigger, and have a single hauling-line from the top to the hook of the stay pendant. The clew-jigger takes the weight of the triatic-stay and leaves enough slack to enable the pendant to be hooked readily.

The men being reported up, the officer of the deck gives the order, *Lay aloft!* when the men detailed will proceed to their stations. The men on the yard will receive the burtons* and clew-jiggers from the tops; when ready, give the order, *Lay out!* The yard-men will lay out together; secure the clew-jiggers to the lift above the burton-strap; hook the burtons; and be in readiness to secure the purchase, when swayed up to them. The men in the tops send

* Top-burtons are always kept hooked to their pendants, ready for use.

177

the falls of the burtons down on deck, send down from the forward part of the main and after part of the fore-top, the topsail clew-jiggers for the triatic-stay pendants, which are bent on deck to their respective tackles and pendants; and the double blocks of the stay-tackles hooked to the thimbles in the pendants and the hooks moused. The fore and main braces, and the clew-jiggers, being manned, give the order, *Trice up, brace in!* At which the main-yard is braced *up*, the fore-yard *in*, the purchases are whipped up to the yards, and the ends of the triatic pendants to the tops. The yards are then secured,* and the purchases hooked and moused, as directed in the foregoing paragraphs. While this is going on, the launch is hauled up alongside, oars, masts, thwarts, sails, &c., are passed out of her, and the booms prepared for her reception. The lower blocks of the yard and stay-tackles are hooked to the rings in her stem and stern posts, and the hooks moused.

Instead of trusting to stem and stern post rings, it is advisable to fit heavy boats with two chain spans; the after one hooked to an eye-bolt that is riveted through the keel nearly under the after thwart, and to the ring-bolt through the stern-post. The forward span hooks to an eye-bolt riveted through the keel forward, and to the ring-bolt through the stem. The purchases are hooked to links in the bight of each span. (See BOATS.)

The falls of the purchases lead thus: That of the *main*-yard purchase, through a snatch-block hooked in an eye-bolt in the deck by the main-fiferail, and then aft. The *fore* leads through one hooked by the fore-fiferail, leading aft. The *fore-stay* through one hooked by the fore-fiferail, and the *main* through one by the main; both the latter on the opposite side of the deck, leading aft.

Everything being in readiness, give the order, *Man the yards!*** At which the men lay in from the yards to the top. The yard purchases are manned, with a sufficient number of men at the stay purchases to take in the slack as the boat is purchased; one man in the bows and another in the stern of the boat. Now give the order, *Walk away with the yards!* When the boat is sufficiently high, order, *Turn with the yards! Man the stays!* At this, a turn is taken, with the yards, two men remaining by each to ease away as the boat comes in, while the remainder of the men man the stays. *Walk away with the stays!* As the boat comes in, the yard-tackles are eased off, until she is over the boat-chocks; then, *Well the stays! Lower away of all!* Both the yard and stay-tackles are lowered, and she is landed on the chocks, the men in the boats overhauling the purchases;

* The men on the yards look out for and report when the lift and burton are taut alike.

** *i.e.* Man the falls of the yard-tackles.

the carpenter and his mates being ready, as she is lowered, to place her properly.

It may be necessary to use the ordinary main-stay tackle, or mast-head pendant tackle, as a fore and aft purchase, to guy the boat clear of the fore-rigging and back-stays of a sailing vessel, or the smoke-stack of a steam frigate.

Hoist in the smaller boats in the same manner, using the yard and stay-tackles.

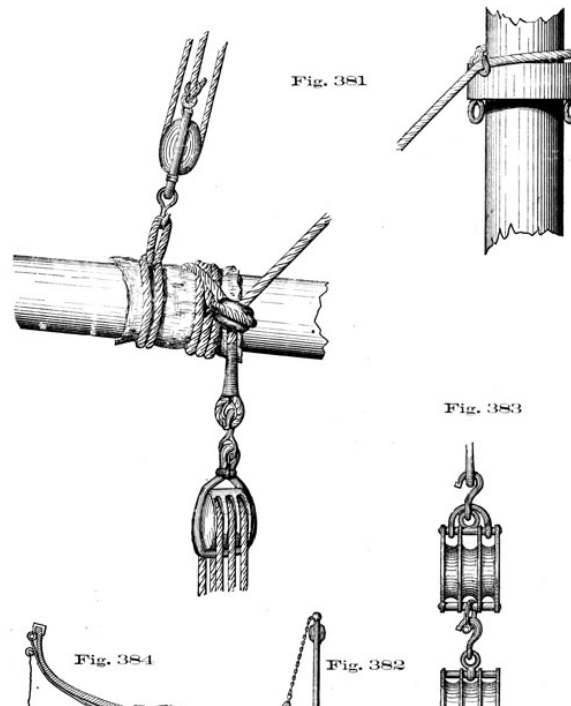
If the boats have any water in them, it is well, when a little way up, to "*avast hoisting*," and let it run out, or wash out any sand or dirt that may be in them, though a heavy boat should not remain long on the purchases.

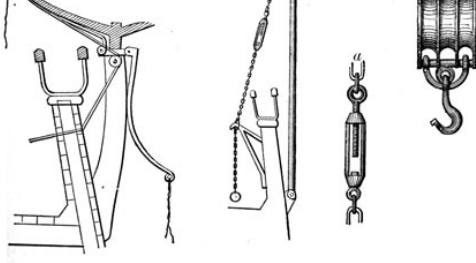
After the boats are in (or out) give the order, *Lay out!* The men lay out on the lower yards, cast off the lizards, unhook the burtons, &c.; the topmen cast off the end of the stay-pendant-hands being stationed by the whips and the braces manned; give the cautionary order, *Stand by to lower away together!* then order, *Haul taut, Square away!* At this, the purchases are lowered on deck, the yards squared, the clew-jiggers taken off the lifts; the men on deck make up the purchases to be stowed away, and having given the topmen sufficient time to stow their gear, give the order, *Lay down from aloft!* when all the men are to leave the tops.

Winding Pendants, Fig. 381, Plate 74. In lifting the heaviest boats the upper block of the yard tackle hooks into a *winding pendant*. This pendant is fitted with a hook in the upper end which hooks to a bolt in the lower cap, or the pendant goes around the topmast above the cap and hooks into its own part. The other end of the pendant has a thimble for the hook of the upper yard tackle block. The bight of the pendant is hauled out to its place on the lower yard by a whip on the lower lift, and is secured to the yard by a stout lizard which traverses on the pendant. Be careful in taking the turns of the lizard around the yard and pendant to take them above the bull's-eye of the lizard, otherwise the strain is taken by the lizard and yard-arm instead of being transferred to the lower mast-head.

To Hoist in a Launch when underway under steam, or having the wind aft. Should it become necessary to hoist in a launch when underway, when circumstances do not permit of heaving to or stopping the engines, secure the yards as usual, and haul the launch up, say on the port side, get a stout hawser from the port quarter and secure it to the stern of the launch; secure it also inboard. Get the purchases up, hook and mouse-them, and proceed to hoist her in as before directed. The only difficulty is, that with headway on the vessel, the moment the boat is freed from the resistance she meets with in moving through the water, she will surge forward with a violence in proportion to the speed

Plate 74





of the vessel, and endanger the yard and purchases. The hawser from the quarter to the stern of the boat prevents this, and renders the operation, as soon as the boat leaves the water, as simple as under ordinary circumstances.

This evolution was performed by the "Constitution" during the memorable and exciting chase, in which she escaped from the British squadron, in July, 1812.

It is well when hoisting in a heavy weight to use a preventer fore-brace leading from the bowsprit end.

On board modern ships the distance between the fore and main masts is so great, that the fore-yard tackle acts very obliquely. For this and other reasons, it would be a good plan to have derricks expressly fitted for getting the boom-boats in and out; purchasing the sheet-anchors, guns and heavy weights generally, to the great saving of the yards. These derricks may be rigged temporarily of spare spars, or fitted like the modern fish-boom for the express purpose.

On board modern iron-clads a derrick rigged similar to our fish-boom is used exclusively in hoisting in and out torpedo boats and steam launches.

Launches carried on the Rail. Many of our modern vessels carry their launches on the rail, instead of stowing them amidships between the fore and main masts.

To support these boats there are fitted two stout davits, usually of iron, together with iron cradles on which the bilge of the boat rests. The cradles are supported under their centres by shores, on which the keel takes. The ends of the cradles are hinged, and can drop down clear when the boat is being hoisted or lowered.

The davit heads are supported by chain guys, spans and topping-lifts. One end of the topping-lift is shackled to the davit-head, and the other has a large ring to fit over the head of a curved iron stanchion or "strong-back," stepped inboard abreast of the davit. The topping-lift has a second ring a few feet out from its inner end, which is passed over the head of the strong-back when the davit is topped up for sea. Fig. 382, Plate 74. The topping-lifts are also provided with turn buckles, for use in setting up, Fig. 382 a.

To Hoist in the Launch. The davits are rigged out and the boat is hauled under them and hooked on. For heavy boats a triatic stay is got up, and the stay-tackles hooked into stout links at the davit heads and steadied taut. Walk away with the falls, and when these are nearly two blocks a hook in the breech of the upper block is hooked into a shackle on the lower block, Fig. 383. A rope rove through a hole in the bulwarks around a snatch-cleat on the cradle shore, and clamped to the inner gunwale with one of the gripe clamps, is used forward and aft to prevent the boat from swinging too far inboard as

the davits are topped up. Usually a boat gripe at each end is used for this purpose. Fig. 384, Plate 74.

When ready for easing in, top up on the davits by hauling on the triatic stay-tackles, put the topping-up rings of the chain topping-lifts over the heads of the strong-backs, raise and secure the outboard ends of the cradles.

Now get a strain on the falls, which have been slacked off in topping up, unhook each upper block from its lower one, and place the launch in its cradle. Unreeve the easing-in lines, and use them (generally) as a part of the gripe fastenings.

The object of hooking the upper and lower fall blocks together is to prevent the boat from easing down while topping up the davits and fouling the cradle; besides, leaving only the slack of the falls to be taken through after the boat is topped up.

To Hoist out the Launch. Having rigged the purchases, &c., as before, cast off the gripes, pull up on the falls, hook the blocks together, top up by the stay purchases, shift the topping-lifts, unclamp the cradles, ease away on the stay tackles and haul on the easing-in ropes. When rigged out, get a strain on the falls, disconnect upper and lower blocks, and lower away together on the falls.

Getting in Guns on Covered Decks. Fig. 385, Plate 75. After bracing the yard over the port through which it is intended to take the guns, secure the lizard of the pendant round the yard, five or six feet outside of the ship, and hook the top burtons just outside the lizard.

Haul taut, and bring an equal strain on the burtons and lifts. Hook a rolling-tackle* on the opposite side of the yard, and bowse it well taut. Pass the end of the pendant of the gun-purchase through the thimble of the lizzard: take the end up and make it fast round the topmast just above the lower cap. To the eye of the pendant, which should hang a few feet below the yard, is hooked one block of a double purchase; overhaul down the lower double block with the fall part leading from it *up* through a single block lashed securely on the quarter of the yard, directly over the gangway; then through a block at the mast-head and down through a leading block on deck.

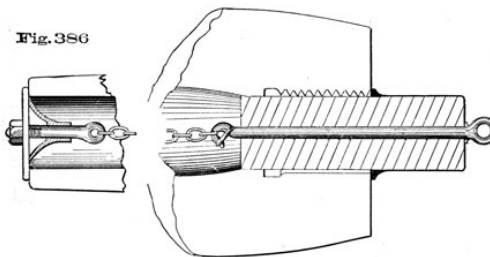
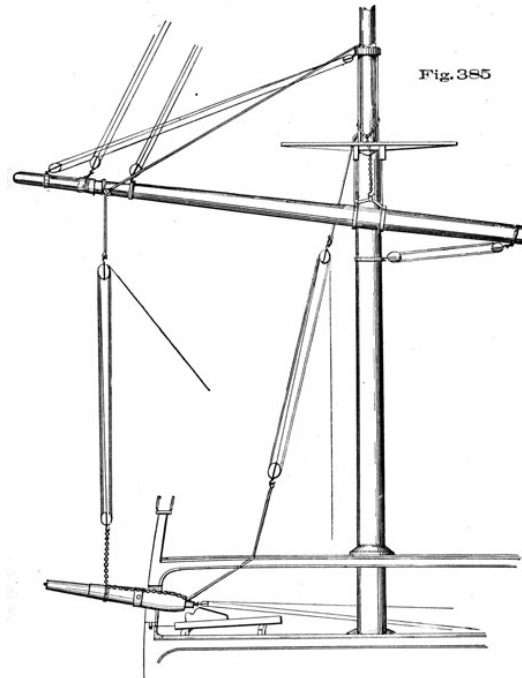
An ordinary treble purchase fall, leading from the upper block, as in the figure, is more common.

Have the port lined with pine boards to keep it from being chafed. Sheet-iron will take up less room and give better protection.

Bore a hole in the deck or decks through which it is

* ROLLING TACKLE. A stout luff hooked well out on the opposite yard and to a strap around the mast below the truss, to relieve the inboard thrust. This should be used whenever the yard is topped up, in purchasing

Plate 75



intended to pass the garnet, as nearly as possible over the rear end of the gun-carriage, and as near in a line with the centre of the port into which the guns are to come as the beams will allow. Pass the upper end of the garnet through the hole, and turn in the thimble, to which hook the pendant tackle. Place a tackle across the deck, ready for bowing the gun into its carriage through the port.

Bring the gun under the yard and sling it as follows: place one bight of the slings over the cascable, and pass the lashing, which is attached to the slings, round the chase, at such a distance from the trunnions as will allow them to go into the trunnion-holes, without bringing too great a pressure of the slings against the upper port-sill. Then lash the gun-purchase to the outer bight of the slings and sway away. When the breech of the gun is above the port-sill, hook the garnet and the thwartship tackle to the cascable, and bowse on both.* When the slings bear hard on the upper port-sill, lower the gun-purchase, and bowse on the garnet until the breech is high enough for the trunnions to clear the cap-square bolts in the carriage; then bowse on the thwartship tackle until the trunnions are over the trunnion-holes, lowering the purchase as required to bring the gun into its place.

As each gun is mounted, unhook the purchase and garnet, take off the slings, run the carriage to its proper port, and place another for the next gun.

Taking in Guns over all. Sling the gun slightly breech heavy, to render it more manageable. If it is to be mounted on the spar deck, place the carriage in the gangway; if on the main deck, close to the main hatchway on that deck. In place of the garnet, hook the stay-purchase for lowering the gun into its carriage.

Getting out Guns through Ports. Secure the yard as in getting in guns, and sling the gun in the same manner. Hook the garnet and haul it well taut, so as to raise the breech of the gun as much as the port-sill will permit; hook or toggle the gun-purchase, and sway away. As soon as the trunnions are clear of the carriage, haul it from under the gun, ease away the garnet, and let the gun go out the port. As soon as the gun is perpendicular to the purchase, unhook the garnet and lower the gun into the lighter, or on the wharf, as the case may be. Use thwartship tackle if necessary.

If the gun is to be taken out over all, the stay tackle is to be substituted for the garnet, only it is hooked to the same end of the slings as the gun-purchase, and the lashing on the slings is to be passed around the chase of the gun, as near the trunnions as possible.

* If available, a large triangular link, secured in the cascable hole by the pin of the cascable will be convenient to hook in the garnet and thwartship tackle.

182

Hoisting out Damaged Guns. It may happen that the gun to be handled has had the trunnions or cascable shot away or injured. In a case of this kind, on board the U.S.S. Vermont, the trunnions and cascables of the spar-deck guns had been broken off previous to their delivery to purchasers who had bought them for the metal. To sling the guns in this case a toggle was placed in the muzzle and a rope strap rove through its own bight around the breech. The breech strap and toggle were connected by a back lashing, and the gun hoisted out *muzzle heavy* by the yard and stay tackle hooked into the bight of the strap.

Throwing Guns Overboard. The gun's crew being assembled at quarters, remove the pin and chock from the cascable, into the jaws of which place a strap; hook the double block of the train tackle into the housing-bolt over the port, bend its single block into the strap; remove the cap squares, and place a round block of wood on the sill of the port high enough to let the chase bear on it when slightly depressed; raise the breech as much as possible without lifting the gun out of the carriage. When all is ready, man the train tackle well; have the handspike-men also ready to assist in raising the breech; and if the vessel is not rolling, it will be well to have additional handspikes under the rear of the carriage to lift it also, so as to give free egress to the gun. When all is ready, give the order; "All together-launch." In a gale of wind, advantage should be taken of a favorable roll to give the word, that the action of the sea and of the men at the guns may be simultaneous.

If the guns are to be thrown overboard in shoal water where they may be subsequently recovered, they must be buoyed, and care is to be taken that each buoy-rope is of a proper length, and strong enough to weigh the gun. The best mode of securing the buoy-rope to the gun is to form a clinch, or splice an eye in the end which goes over the cascable, and take a half-hitch with the bight around the chase of the gun, and stop it with spun-yarn.*

The buoy must have sufficient buoyancy to float the rope when saturated; or in deep water, a smaller line may be used for the buoy, and attached to the rope intended for weighing the gun, that it may be hauled up when wanted.

Other Methods for getting in Guns. For taking in or hoisting out main-deck guns, no purchase that can be rigged is so handy and safe as the derrick excepting the cat.

But the cat-head is only available when it overlooks a port: the derrick may be rigged anywhere if a suitable spar is to be had.

* Guns taken out of a ship to lighten her when aground should be hoisted out and *rafted* clear, if there is any danger of bilging on them.

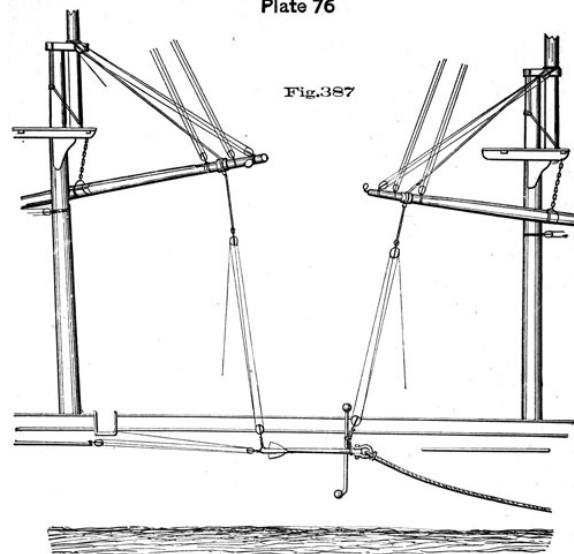


Fig. 387

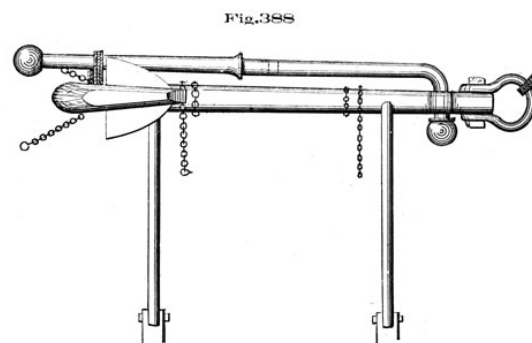


Fig. 388

Whichever of these two methods be adopted, it must be observed that the longer the slings are, the less will the lower purchase block nip against the upper port-sill. If the cat-block be used, the hook should stand outward, and whatever kind of purchase be used in working guns through ports, the port should be lined, and the port-lid unshipped.

The use of the derrick will be described further on.

Toggle for Breech-Loading Rifle-Gun, Fig. 386. To sling a breech-loading rifle-gun, the breech mechanism having been removed, place in the breech an iron-bound toggle, Fig. 386. Set up at the muzzle with an iron cross-piece, as a washer, and a screw. The toggle affords a bearing for the chain slings.

The toggle must be of wood to avoid injury to the rifling. In any case, as the guns have little preponderance, they will be nearly centre-hung by lashing the slings at the trunnions.

The heel-tackle is hooked into the eye-bolt in the end of the toggle.

Purchasing Waist Anchors. Having secured the lower yards with the lifts and both burtons, the yards being topped up, if need be, on the side used, brace in the fore and *forward* the main-yard, and get an equal strain on the supporting tackles, Fig. 387, Plate 76.

The purchases used are the yard-tackles with the winding pendants, the lizards of the latter regulated so that the purchase will take the anchor clear of the side, Fig. 387.

The anchor being brought alongside in a lighter with the crown aft, pass a strap around the shank just inside the ring; the anchor being stocked, lash this strap to the stock. Hook the fore purchase into this strap, and hook the main purchase to another strap passed down over the shank and under the arms, the tackle hooking into the upper bights. The forward strap should be a long one, and lashed to the stock

about one-third the distance up, to keep the stock perpendicular when the anchor is raised. Use fore-and-aft tackles as necessary.

Having swayed the anchor up, rouse it in with thwartship-jiggers, place the bills in shoes, or its arm upon the gunwale, place the shores and pass the lashings, unstocking the anchor.

The anchor rests on two shores, which may be of wood resting in saucers and secured by laniards, or they are of iron, and work on hinges, Fig. 388. The shore supports the anchor, and also throws it clear of the ship's side when let go.

To hold the anchor to the side, there are usually chain-lashings, the upper ends secured by seizings of ratline stuff; two from eye-bolts in the side below the anchor acting as jumpers to keep the anchor down, two on the shank, and one on the inboard arm to retain the anchor at the side.

In preparing to let go, the chain being bent and the

anchor stocked (by raising the upper arm of the stock with a top-burton and lowering it into place for keying), cast off the jumpers and the lashing on the arm, and stand by to cut the seizings of the shank lashings.

To transport a Waist Anchor to the bows. Get the anchor ready for letting go, and at the same time make the necessary preparations for weighing it. When ready, let go the anchor and heave it up to the bows, purchase it there with the cat and fish.

Or transport the anchor wholly by purchases, as follows: Stock the anchor, brace the main-yard up *sharp* and the fore-yard *in* a little, use the purchases, &c., previously described in getting the anchor into place. The fore-yard hooks to a lashing around the shank inside the stock, and the main to a lashing around the crown and both arms.

When the anchor is clear of the ship's side, ease away on the main-yard, hauling on the fore-yard tackle until the anchor hangs by the latter purchase. Then man the fore-brace and brace the yard up handsomely until the anchor is far enough forward to hook the cat; when lower, hook the cat and rouse it up to the cathead. Unhook all purchases and send them down.

You may hook the cat and fish as soon as the drift permits, and it is advisable to do so, as the latter, particularly, will be serviceable in transporting to the bows.

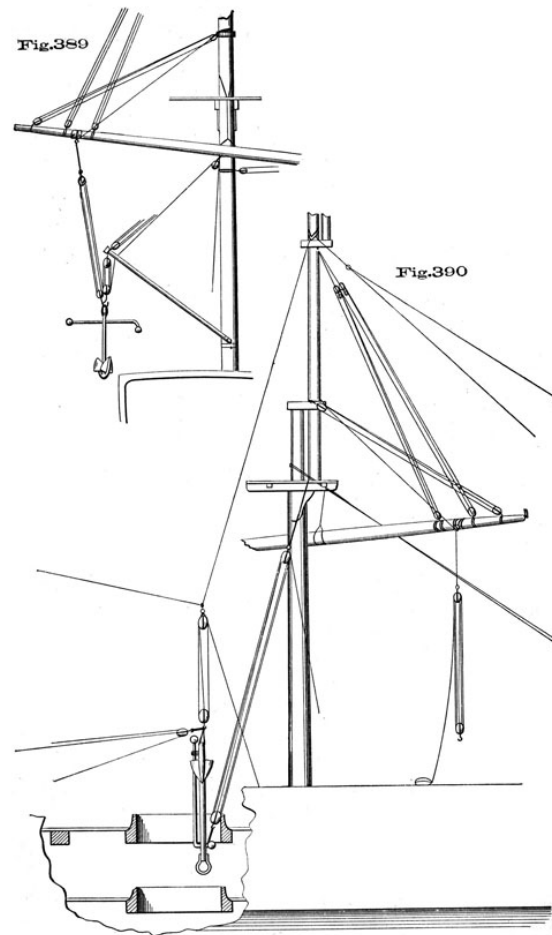
The fore-yard should not be braced in so far that the burtons and lift will take against the rigging, for in bracing them up again they would not bear an equal strain.

By this plan, you may transport anchors from the bows to the waist, but there is always risk attending the bracing of a yard with a heavy weight upon it, for the supports may be broken in detail, as the strain is shifted, and the yard sprung or carried away.

Moreover, in long modern ships, the distance through which the anchor must be transported requires a very great swing of the fore-yard. If this plan is adopted, good hands should be stationed to attend the burtons, and at the first indication of the slacking up of any one, to haul it taut again, and for that purpose jiggers clapped on the fall would be a material assistance.

When transporting waist anchors, the cable should be unshackled and a hawser, stout enough to weigh the anchor in case of accident, bent in its stead.

To transport a Waist Anchor inboard. Having previously secured the lower yards, hoist the anchor inboard with the fore and main-yard tackles, and transport it forward along the deck, the deck being wetted down and mats placed under the anchor and ball of the stock. If the vessel has a flush spar-deck, the anchor is dragged far enough forward to hook on the hoisting-out tackles immediately. But should the vessel have a topgallant forecastle,



185

as is generally the case, the anchor is raised from the deck to the fore-castle by means of the lower pendant tackles of the side, and a mast-head pendant tackle. The anchor is then hoisted outboard by the mast-head pendant tackle and the fore-yard tackle, stocking it as soon as it is raised clear of the fore-castle. If the ship is provided with a fish-boom, the fish may be substituted for the mast-head pendant tackle in hoisting the anchor out, Fig. 389, Plate 77. In either case, both purchases used are commonly hooked to the ring, or to a strap near the ring.

The anchor being outboard, lower it by the fore-yard tackle, and hook on the cat as soon as convenient, to bring it to the cat-head.

Mast-head. Pendant Tackles. Fig. 390. These are purchases, double or treble, the upper block lashed to a pendant from the topmast-head. A top pendant may be used to form the pendant, taking a turn with it around the topmast-head, securing the ends together, and lashing the upper block into the bight.

A mast-head pendant tackle is guyed clear of the top by a guy from forward or aft, as the case may be, usually secured to the pendant just above the upper block.

These purchases are very useful in hoisting heavy articles out of the fore or main hold, or in any case when the purchase is required immediately over the fore-and-aft line. They could be used in place of the stay-tackles in purchasing boats, should there be no triatic-stay.

Transporting Spare Anchors. Fig. 390, Plate 77. The anchor intended to be stowed in the fore hatch is hoisted on board, crown up and unstocked, by means of the fore-yard and mast-head pendant tackle, the latter being abaft the mast. Should the anchor stow in the main hatch and forward of the main-mast, use the main-yard and a mast-head pendant tackle at the main, and forward of the mast. Use, in addition to the purchases, fore-and-aft and thwartship tackles as necessary, and a guy on the ring of the anchor in getting it into place. The anchor stows up and down, and on modern vessels usually on the forward side of the

fore hatch.

In transporting this anchor to the bows from the fore hatch, hook the mast-head pendant tackle to a stout strap around the crown, and a tackle leading aft on the lower deck is hooked to the shank of the anchor to guy it clear as it goes up. Cast off the lashings, sway up, and as the crown comes above the upper deck use the fore pendant tackle, hooked into a strap around the shank near the place for the stock, in getting the anchor forward of the mast. Having stocked it, transport it over the bows by means of the purchase on the fore-yard and fish, as in the case previously described of transporting anchors inboard. When high enough, and clear of the side, lower away to the water's edge, hook

the cat to the ring, and rouse it up to the cat-head, send down the purchases and square the yard; bend the cable, fish the anchor, and get it ready for letting go.

Should the anchor stow in the main hatch, hoist it out with the pendant tackle from the main topmast-head, and transport it forward on mats on deck.

Shoring up a Lower Yard. Fig. 391, Plate 78. To get in a very heavy weight, lower the main-yard some distance below its slings, housing it over athwartships so that the truss arms will be clear of the mast and on the side nearest to the weight, which rigs the yard out further on that side. Top up the yard on the side used and lash it to the mast, having first passed old canvas in wake of the lashings. Use rolling tackles on the opposite yard-arm, and hook both top burtons in wake of the purchase on the upper yard-arm, Fig. 391. If the jeer-blocks are needed to form the purchase used, hang the yard by pendant tackles from the lower pendants.

Get the spare main-topmast up and place its heel in a shoe in the water-way under the yard. Shore up the deck underneath and lash the head of the topmast with a cross-lashing to the after side of the yard. Use a spare gaff at about half the height of the topmast from the deck as a shore, the jaws lashed to the derrick and the peak to the mast. Reeve a topping-lift from where the topmast-head is lashed at the yard, to a block lashed above the lower cap. The topmast should be further supported by head guys forward and aft, which are omitted in the figure.

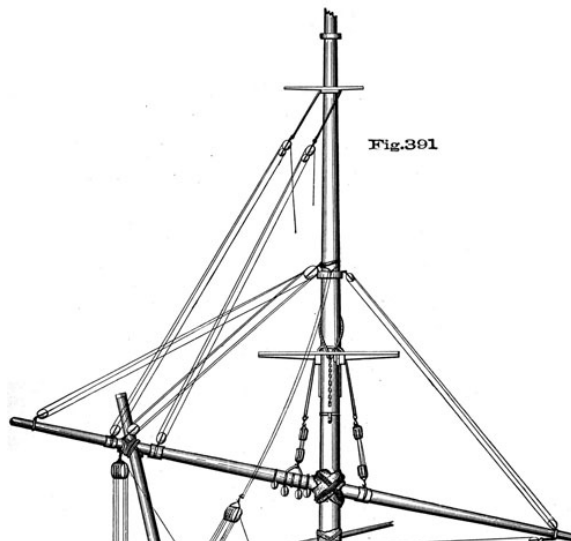
The upper block of the yard purchase is lashed to the lower yard and topmast with a long lashing. Both purchase blocks treble, or at least one of them fourfold, if such blocks are available.

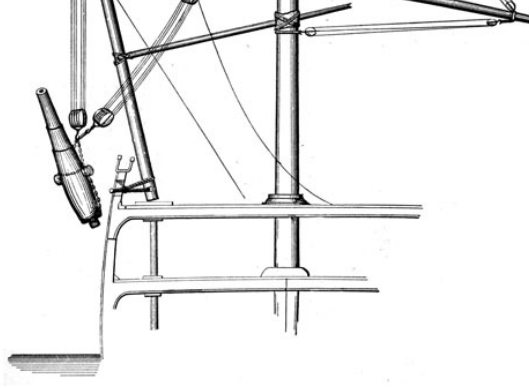
The stay purchase consists of a double pendant from the lower mast-head, supporting a treble purchase. With falls, &c., of the following dimensions, a vessel sparred as heavily as the Trenton could safely raise a 10-inch rifle gun: yard purchase, 8-inch falls; stay purchases: two parts of pendant, 10-inch; falls, 8-inch; topping-lift, five parts of 6-inch.

A hawser rove from forward through a top-block at the fore cap may be secured to the eye of the stay pendant so as to haul the stay purchase forward to plumb the hatchway if the weight is to be struck below. If the weight is a gun to be placed on the gun-deck, sling it breech heavy. Fig. 391.

The Derrick. We have so far dealt chiefly with the lower yards in describing purchases, but the derrick possesses advantages which render it superior to a yard in some respects, for lifting heavy weights. The derrick transfers the weight to the deck, which can be well supported by shores from below. It removes all anxiety for

Plate 78





187

the safety of the yard and mast; it can be placed vertically or at an angle, supported either with or without the aid of a mast; it is soon rigged, and as quickly dismantled. These features are sufficient to recommend it. Moreover, it may happen in our modern ships that the vessel is fore-and-aft rigged, or so lightly sparred as to render her yards unfit to support heavy weights, or the yards themselves may be sprung, and unavailable for that reason.

The following instance of the successful use of a derrick is therefore given to show how derricks may be rigged and handled:

Recently the U.S.S. New Hampshire was towed from Norfolk to the Training Station at Newport, R.I., to be fitted up at that place. She had her topmasts fidded, lower and topmast rigging set up. The other spars, davits, &c., were on deck in an unfinished condition, all the iron-work for the yards, such as truss and sling bands, shoulder bands, and burton straps, being stowed below. The vessel carried on her spar deck fourteen boats, two being launches of the largest size, some stowed bottom up. In addition, there were two ten thousand pound anchors on deck, one in each gangway. It was required to hoist out the boats and to place the anchors on a lighter for transportation to the shore.

The boats were taken in hand first. The main-yard being the largest spar available, was rigged as a derrick. It was about 75 feet long, the size for a vessel of the Portsmouth class, the ship being much undersparred.

The lower yard-arm was stepped in a shoe close to the water-way, abreast of the main-mast. Fig. 392, Plate 79.

At the upper end, about the place for the burton strap, was lashed the upper block of a treble purchase, 6-inch fall. At the same point were hooked into suitable straps two topping-lifts, the upper one being the top burton of the side, the lower one a pendant tackle hooked into a strap around the lower mast, just above the trestle-trees-block underneath the top.

A burton from under the yard-arm, close to the purchase block, led outside to a toggle in a lower gun-deck port, acting as a jumper. An outrigger for this jumper would be needed in a vessel with less beam.

There were, in addition, forward and after guys from the fore and mizzen chains to the place for the upper purchase block. The deck was shored up under the heel of the derrick. Neither belly guys nor fishes for the lower yardarm were required, although their positions are indicated in the figure. The derrick, until rigged, lay across the rail, and was raised into position by means of the mast-head pendant tackle; topped up by the topping-lifts when the lower yard-arm was clear of the rail, the heel carried into place by heel tackles. The derrick purchase took the place

188

of a "yard" in hoisting out. For a "stay" there was fitted the mast-head pendant tackle, treble purchase, 6-inch fall, hung with a long lashing from the topmast-head.

Each boat was brought into position under the purchases by rollers and fore-and-aft tackles. In the case of the launches stowed bottom up, they were lifted clear of the deck by the mast-head purchase and capsized with the assistance of the derrick purchase, hooked to the same slings, underneath. The slings passed for this purpose were simply turns of stout manilla, one sling being forward of the centre of the boat, another aft, and the two joined by spans above and below, both slings kept from drawing together by back lashings over the stem and stern. Fig. 393, Plate 79.

The boat being upright was slung with a span for hoisting out, as in Fig. 394, the span for the launches being four turns of 5-inch manilla, fitted so as to render and take an equal strain. Particular attention was given to the *belly lashing* passed around the middle of the boat, it being made to bear an equal strain with the span. Plank spreaders were placed inside the boat between the gunwales in wake of the belly lashing. The span passed under the fore-foot and counter, with back lashings, as in the figure.

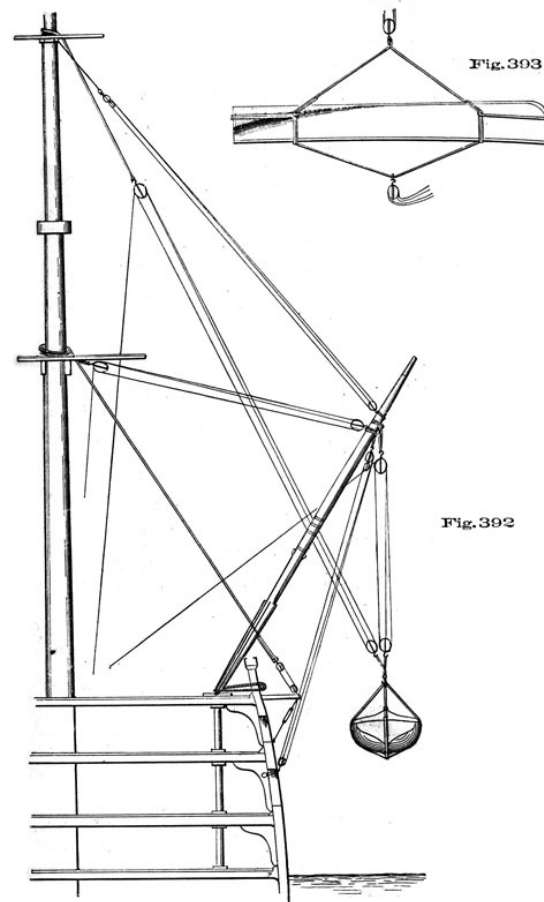
In hoisting out, the mast-head and derrick purchases were lashed to the span, the boat lifted by the mast-head purchase and swayed out and lowered by the derrick purchase.

In using the same tackles to get out the sheet anchors, both were lashed to the shank of the anchor at its balancing point, the lashing being steadied by stout back lashings from the ring and crown. Fig. 395.

The purchases described would have readily lifted 11-inch guns for a ship's battery; had it been required.

An Upright Derrick. To land the above mentioned anchors from the lighter, an upright derrick was rigged on shore. It consisted of a spar 20 feet long and about 8 inches in diameter. The heel rested on the ground, the head being supported by four guys placed as nearly as possible at equal angles, and some 50 feet from the heel of the spar. The spar was raised by jiggers on two of these guys, the other two being anchored off in the water, to get them at the required angles. The derrick being upright with one (double) block of the purchase lashed to its head, the lighter was hauled in close to the shore and the lower block of the purchase lashed inside the balancing point of the first anchor, in order to drag rather than lift. The purchase fall led from the upper block through a leading block lashed to the heel of the derrick. The anchor was raised by the purchase just clear of the lighter and was allowed to slide on skids to a point some 15 feet from the base of the

Plate 79



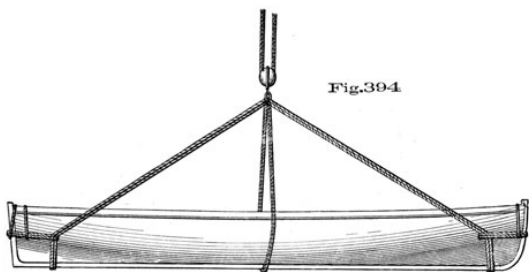


Fig. 394

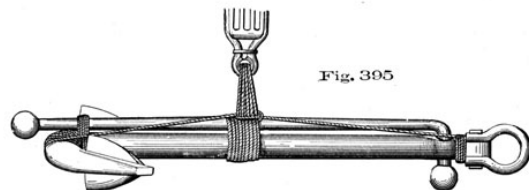


Fig. 395

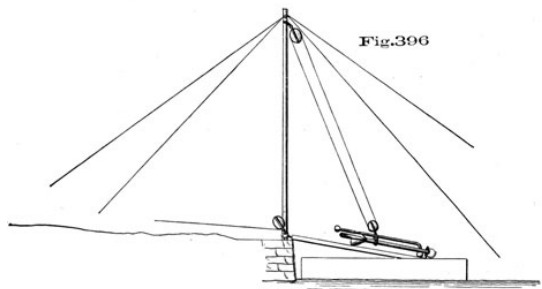
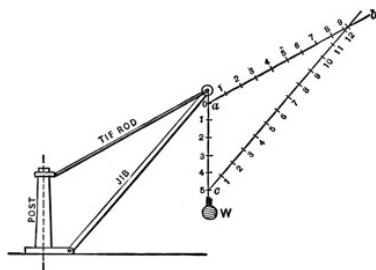


Fig. 396

derrick, and each anchor was landed in turn abreast of the derrick and some 15 feet distant from the heel.

The purchase used was 4 1/2-inch rope, guys 4 1/2-inch. Fig. 396, Plate 80.



A Practical Method of Ascertaining the Stress on Derricks. In the figure, divide any part, *a c*, of the supporting line of the weight, *W*, into a convenient scale representing the weight suspended, (in this case 5 tons).

From *a* draw *a b* parallel to the tie rod, and from *c* draw *c b* parallel to the jib, cutting *a b* at *b*. The tension on the tie rod will be given by *a b*, referred to the scale *a c*, and the thrust on the jib will be represented by *b c* referred to the same scale.

Scales for the measurement of strains on any derrick formed of spars on shipboard may be constructed as in the foregoing case. Attention must be given to the relative positions of the derrick and supports which may vary from the above.

CHAPTER XII.

STOWAGE AND SOURCES OF SUPPLY.

THE HOLDS-BUREAUS-NAVY YARDS.

THE plan of the holds of a second-rate, Plate 81, shows the internal arrangement and disposition of the storerooms, &c.

Owing to the great differences in construction of modern vessels it is impossible to lay down fixed rules for their stowage, but certain general principles apply to all ordinary forms of steam vessels, viz.:

1. The weights of engines, boilers, tanks, ballast, &c., which are permanent fixtures for the cruise, must be so distributed according to the form of the hold, that the vessel may be brought down to her supposed best lines; which trim can be afterwards kept in the distribution of the provisions, coal, and other articles.
2. The proper stowage and security of all articles.
3. Economy in space, and a general regard to keeping near at hand certain articles for immediate use.
4. To avoid, as far as possible, taking any article into the hold until it has been properly cleaned.

The first thing to be attended to in stowing a hold is, to prepare the hold itself by having it thoroughly cleansed and white-washed, and the limbers cleared, and then to stow the ballast.

The weight of ballast used in men-of-war is generally small; the engine, boilers, coal, &c., being nearly sufficient in weight for the purpose required, and but little dead weight will be needed to perfect the trim.

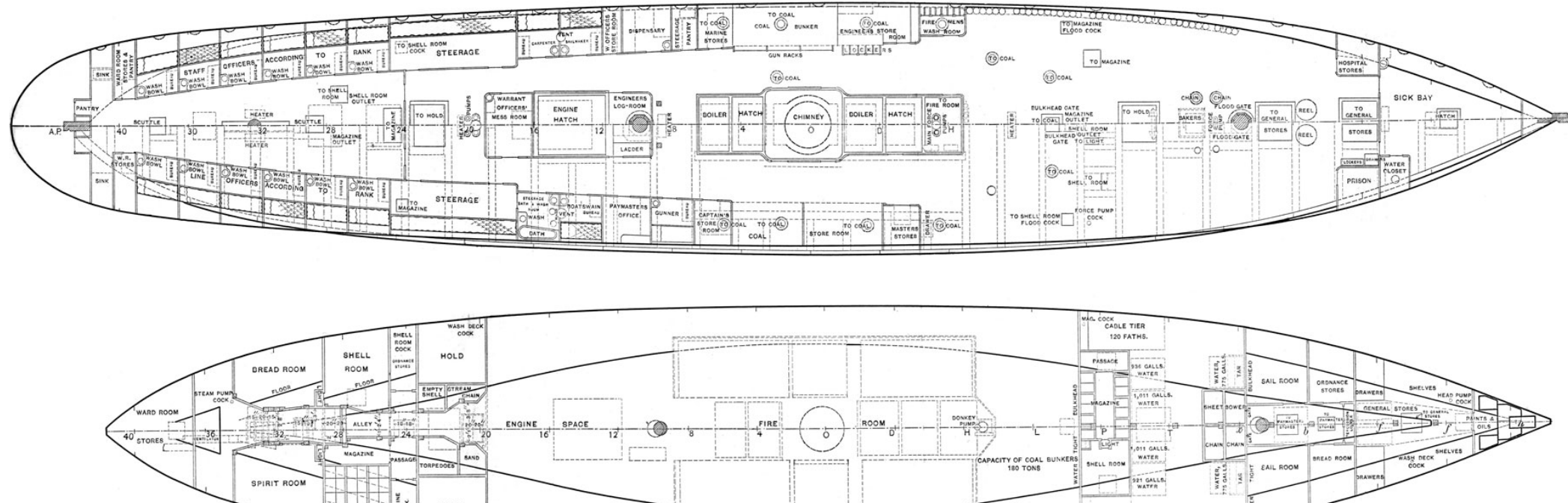
Pigs of iron of square or half-round section, and about thirty inches long are used for ballast.

The pigs are generally laid directly on the skin alongside the keelsons, the limber boards being kept clear. They are not unfrequently stowed in the coal bunkers.

In placing the ballast, be careful not to form an uneven floor for the tanks above it, and still place it so compactly that the weight shall bear equally in the body of the hold.

Winging ballast, or spreading it athwartships, tends to make a vessel roll, and building up amidships, to keep her steady. Without venturing on details, it may be remarked,

Plate 81



that the plan of keeping the ballast in the body of the ship, and clear of the extremities, seems to be most generally approved of; while at the same time care should be taken to keep her on, or parallel to, the line of flotation, designated by the builder. Make a draft of the ballast, indicating the exact number of pigs, the position they occupy, and their weight.

After the ballast, are stowed the water-tanks, often on a skeleton floor, or better, iron chocks. The tanks are made to fit the form of the hold, and are put, according to marks, in their proper places. They are slung by placing an iron toggle, Fig. 209, Plate 28, in the man-hole.

If there be more than one row of tanks, and the manholes are near the corners, place them so as to have four man-holes close together; this gives more room for the storage of gear, and keeps the man-holes clear.

A draft of the tanks, showing their capacity and position, is kept by the navigator.

When stowed, the tanks on top should form an even surface, and be placed compactly. They are then wedged with slips of wood and the seams caulked and pitched so that no dirt can work down between them.

A *bilge* tank is one that has the corners cut off to fit the side or bilge of the ship.

All ships are now fitted with apparatus for condensing and aerating water. The tanks nearest the boiler are called *receiving* tanks, and receive the water fresh from the condenser. Other than condensed water should pass through a filtering tank.

The tanks being stowed and filled, the most bulky, *wet* provisions, are to be stowed next nearest the wings, and so that each kind may be got at. *Pork* is on the starboard side, *beef* on the port. The oldest provisions should be used first, restowing, when necessary, to get them uppermost.

Wet provisions are pork, beef, pickles, vinegar and molasses. The last two stowed in the spirit room."

Dry provisions are flour, sugar, beans, coffee, &c.

If the main hold is too small to hold all the *dry* provisions, some must be stowed forward. In this case, wet provisions form the ground tier, and dry provisions the top tier.

Where the stowing of wet provisions ends forward, or "in the breakage" of the fore hold, are stowed all the *naval stores*, as tar and tar oil (in tanks), pitch (in barrels), &c., and all the movable lumber, the forge and anvil, carpenters' chest and bench (when stowed below), spare buoys and buckets.

Iron racks are fitted under the beams in the hold for the stowage of planks, oars, and other small lumber, spare pieces of iron, and any spare gun gear not triced up under the upper deck. In a vessel with two holds, the after hold.

would contain spare gun carriages, lower caps, and other articles that will not probably be needed.

All wood for the galley should be *barked*, and all lime *slaked* before being received on board. Both are stowed in the fore hold.

Heavy purchases, such as the jeers, top-tackle pendants, and falls, anchor gear, and miscellaneous purchases, are stowed on platforms in the wings, above the provisions, and such platforms are called "cable tiers."

Wash-deck gear, coaling shovels and buckets, are stowed near the fore hatch; a good deal of the wash-deck gear is stowed in the chain chests, if the channels are broad enough to admit such chests.

Kedges, when not kept in the chains, are stowed in the hold; the stream anchor is secured up and down at the forward side of the hatch, crown up, unstocked, ready for hoisting out.

Triatic-stays, and yard and stay-tackles, are usually stowed in the launch.

Hawsers and towlines are kept on reels on the berth deck, the reels being as near the hatch as possible, usually at the foot of the fore hatch. No hawser should be stowed in the hold if it can be avoided, and gun-deck reels, or reels under the topgallant forecastle, may be used in addition to those on the berth deck.

The chain lockers contain the ship's chain cables.

The shot lockers contain the round shot, unboxed empty shell and grape, if supplied. The latter, when issued, is sometimes stowed around hatches on berth deck.

Canister may be stowed in the wings abreast the hatch.

The *yeoman's store-room*, or general store-room, is situated forward, directly abaft the collision bulkhead, if the ship is provided with one. In this store-room are kept all the spare cordage, paints, *painting* and *illuminating* oil, hooks, blocks, thimbles, ship's stationery, spare canvas, spare brooms, squilgees, and other cleaning gear, all hardware articles and tools not put on board for the special use of the engineers' force, or belonging to ordnance stores. In general terms, all small spare articles furnished for the use of the boatswain, carpenter, or sailmaker, are kept in the yeoman's store-room.

The oils mentioned above are discharged into the tanks in the fore peak, from the deck next above, by means of a tap and funnel, there being oil tanks fitted in the store-room for the reception of the oil. This is done as a precautionary measure against fire, and to avoid handling barrels of in. flammable substance below.

For a like reason, turpentine and alcohol are stowed in a "turpentine chest" aft, on the upper deck, to be readily thrown overboard in case of fire, if necessary.

The danger from fire through the ignition of fumes from

193

volatile oils and the like in close places, is always to be recognized in their stowage. Cotton fabrics, waste, or anything that tends to spontaneous combustion by oil soaking in it, should not be stowed in the fore peak, or in any close place, whether easy of access or not.

In vessels having a topgallant fore-castle, such as the one shown in the plan, there is usually a lamp-room, situated under the fore-castle, where the lamps are cleaned, trimmed, &c., and where a sufficient supply of oil is kept for daily use.

The navigator's store-room contains the spare flags, bunting, log and lead lines, boat binnacles, lamps and lanterns, signal halliard stuff, and other articles known as navigator's stores.

The medical store-room contains the medical stores not in actual use. Surgical instruments, and such medicines as are ready for immediate use, are kept in the dispensary and sick bay.

In the ordnance store-room are stored small spare articles of gun gear, sights, cap-squares, &c., and such gunner's tools as are not usually kept in the magazine, armory, or torpedo-room.

The sail-rooms contain the spare sails, hammocks, wind-sails, cots, awnings, &c. The sailmaker's bench is also stowed in the sail-room when not in use.

In a ship having two sail-rooms, one is usually reserved for a complete suit of topsails, mainsail and storm-sails, ready to be passed up promptly in case of emergency.

The bread-rooms contain the supply of biscuit.

The shell-rooms contain the loaded shell and shrapnel. For construction of shell-rooms and magazine see Ordnance Manual.

The boilers and engines occupy the space shown in the plan, with coal bunkers on either side extending to the upper decks in this class of ships.

Bunkers are filled through chutes on the deck above, covered by iron plates when not in use.

The paymaster's store-rooms contain the dry provisions and the less bulky or more valuable wet provisions. The room selected for the latter is known as the "spirit-room." Or, one of these rooms may contain portions of the spare clothing and small stores. There is frequently an additional paymaster's store-room aft for the articles of clothing.

Clothing and bread rooms are lined with tin to exclude vermin.

Casks should be placed fore and aft, bung up, and *dunnage* (small pieces of wood) used under the chimes to prevent shifting.

The *chimes* of a cask are the projection of the staves beyond the head.

The *bilge* of a cask is its largest circumference.

13

The *bung* of a cask is always to be found between the rivets of any two opposite hoops.

The stores received on board at a navy-yard, or purchased abroad, are supplied under the cognizance of the different bureaus of the Navy Department.

Bureaus of the Navy Department. The bureaus above referred to are divisions of the Navy Department for administrative purposes. They are eight in number.

The Bureau of Equipment and Recruiting has charge of all that relates to the recruiting, discharging and pay of enlisted persons. It establishes the complements of vessels, and controls the rendezvous and receiving ships. It has charge of the equipment of vessels with rigging, ground tackle, sails, and the greater part of the yeoman's stores, and fuel for all purposes.

The Bureau of Ordnance has charge of all that relates to the offensive and defensive armament of vessels. It, fixes the nature and place of armaments, and prescribes the kind and positions of armor, and dimensions of gun turrets within the carrying capacity of the ship, as determined by the Bureau of Construction. In conjunction with the latter bureau, it determines the location of armories and ammunition rooms, and determines itself the method of construction of such rooms. It prescribes the armament, handiness and speed of all torpedo boats, and all additional details of torpedo boats of less than eighty (80) tons displacement.

The Bureau of Navigation has charge of all that relates to the Naval Observatory, Nautical Almanac, Hydrographic Office, Department Library, and Office of Intelligence.

It furnishes navigation supplies and stores of all kinds. Bills for pilotage are rendered to this bureau, and the Office of Detail is attached to it.

Bureau of Yards and Docks. The duties of this bureau comprise all that relates to the construction and maintenance of docks, wharves, and buildings of all kinds within the limits of navy-yards, and of the Naval Asylum, but not of exterior hospitals or magazines, nor of buildings for which it does not estimate. It repairs and furnishes all buildings and offices in the navy-yards. It supplies water, gas and fuel required for yard purposes. It controls all improvements, fire apparatus, railways and railway tracks maintained for the benefit of the yards, and provides for watchmen and the protection of public property. It furnishes the oxen and teams required for all purposes in the yards.,

The Bureau of Construction and Repair. The duties of this bureau comprise all that relates. to designing, building and repairing the hulls of vessels,

195

boats, spars, capstans, steering-gear,* tanks, blocks, lumber, and furniture for ship's use of the kind made in joiner shops, also the turrets and armor-plating of vessels after the dimensions have been determined by the Bureau of Ordnance. It designs and (after their completion) controls all ship-houses, building slips and dry docks.

The Bureau of Steam Engineering has charge of all that relates to designing, building and repairing the steam machinery and its appurtenances used in the propulsion of vessels, also steam-pumps, heaters, &c., and the steam machinery necessary for turning the turrets. It supplies what are known as engineers' stores, comprising tools, oil, metal of various kinds, and other articles required for maintenance and repair in the Engineers' Department.

The Bureau of Provisions and Clothing has charge of all that relates to supplying the Navy with provisions, clothing, small stores, water and contingent stores in the Paymaster's Department.

The Bureau of Medicine and Surgery controls all that relates to laboratories, naval hospitals and dispensaries, and furnishes all surgical instruments and medicines.

The bureaus design the buildings erected in navy-yards for their purposes, so far as their interior arrangements are concerned, and after their completion (by the Bureau of Yards and Docks) control the same. They each control the pay organization and mustering of the labor connected with them, and contract for and superintend work done under their cognizance. Each bureau estimates for and pays from its own funds the cost necessary to carry out its duties as outlined above.

Where bureaus control buildings outside of navy-yard limits, they erect, furnish and maintain the same, or any other buildings for which they have estimated, and (subject to the provisions of the law) they are charged with the purchase, sale, and transfer of all such outside lands or buildings, and with the preservation of any public property under their control.

The Navy Regulations define more fully the relations of the bureaus to each other, and this subject need not be dwelt upon here, where the bureau organization is only outlined to show under whose cognizance the outfit of a vessel is completed.

The Chiefs of Bureaus of Equipment, Ordnance, Navigation and Yard and Docks are line officers selected from the Navy list not below the rank of commander. The chiefs of the remaining bureaus are known as the Chief Constructor, Engineer-in-Chief, Paymaster General and Surgeon General, and are selected from their respective corps.

* *Steam* capstans and steering-gear, supplied by steam engineering.

Navy-Yard Organization. The commanding officer (usually a captain or flag officer) is known as the commandant of the yard. All communications relating to work from the different bureaus go to him, and he is responsible for the execution of such orders.

The captain of the yard is the next line officer in rank, the executive of the station, and acts for the commandant in his absence. He has charge of the general administration of the yard, watchmen, police force, tugs, fire-brigade, and the mooring and unmooring of vessels.

There are also attached to a yard, officers in charge of the storehouses and stores of each bureau, the civil engineer of the yard representing the Bureau of Yards and Docks.

Stores are furnished from a navy-yard on requisitions made through the proper channels, and by order of the commandant of the yard, from the storehouses of the different bureaus.

The following lists give a general idea of the articles supplied under each bureau:

Equipment and Recruiting. All ground tackle and cordage; thimbles, hooks and boatswain's stores; sails, canvas, and sailmaker's stores; galley and cooking utensils; coal and wood for steaming or cooking; chairs and other furniture (not joiner work) for officers' quarters; water for steaming purposes; deck and bright-work cleaning-gear; coaling-gear; hose, fire-extinguishers; tar; life-preservers; seines; aerator, filters and condensers, for water.

These stores are mostly to be found in the following buildings, &c., of the navy-yard, in charge of the equipment officer, viz.: the sail and rigging lofts, rope-walk (Boston), anchor park, coal shed, and equipment store-house.

On board ship the boatswain, carpenter, and sail-maker have special charge of the equipment-stores in their departments, under the direction of the first lieutenant, who is the equipment-officer of the ship.

Construction Outfit and Stores.-

Blocks,	Oars,
Breakers,	Paints and paint oil,
Boats,	Rowlocks,
Balsas,	Halliard racks,
Casks,	Hawser-reels,
Chests,	Shellac,
Capstans,	Water-tanks,
Dead-eyes,	Scuttle-butts and tubs,
Mast-fishes,	Wire,
Glass,	Turpentine,
Iron ballast,	Varnish,
Spare iron and other metals,	Pumps,
Lumber,	All wooden furniture for
Spare spars,	officers' quarters (except
Caulking materials,	chairs).

Construction stores at a navy-yard will be chiefly found in the following buildings, &c.: spar-shed, boat-sheds, timber-basin, paint, joiner, blacksmith and blockmakers' shops and construction store-house.

The docking of vessels is done by Construction.

On board ship the carpenter has general charge of the construction stores under the direction of the first lieutenant, who makes out all requisitions for articles under construction.

Ordnance Outfit and Stores. All guns, small arms, or other weapons, and their appurtenances powder, shot, and every kind of ammunition, and tools for handling the same; belts and equipments for the guns' crews; torpedoes and their gear (except torpedo spars furnished by Construction), targets and electric apparatus supplied for military purposes.

The gunner is the warrant officer in immediate charge of the ordnance stores; the navigator is the ordnance officer of the ship, and makes out ordnance requisitions.

Ordnance stores are drawn from the store-house, armory and gun-park in the yard, and from the magazine, which is invariably situated outside of the navy-yard limits.

Navigation Outfit, and Stores. Compasses and binnacles; barometers and thermometers; sounding apparatus, flags, bunting, and signalling apparatus for either day or night signals; charts, sailing directions and instructions, drawing, musical, surveying and navigating instruments; lamps and their appurtenances, lamp-oil (except for engineer's department); chronometers and time-pieces, log-lines, reels and glasses; spy-glasses; fog-horns, library books, printing-press and materials, and electrical apparatus for ship's use, for bells and lights.

These articles are in charge of the navigator. The chronometers are generally received on board from the Naval Observatory; other navigation articles from the store-house in the yard.

Steam Engineering. Engines and boilers, together with their appurtenances, and tools, stores, lamps, &c., used in the engine and fire room.

The coal and water for steaming purposes come under equipment, as stated above.

Engineer's stores are supplied on requisitions made by the chief engineer of the vessel, and are expended under his direction.

The outfit under the

Bureau of Provisions and Clothing, includes the supply of water for drinking and cooking purposes, provisions, clothing, and "small stores," the latter comprising candles, tobacco, sewing materials, mess-gear, and other minor articles.

These stores are in charge of the paymaster.

198

Medical Stores include the medicines, surgical instruments, and other appliances for the use of the surgeon, as well as provisions for the sick and wounded; this outfit is in charge of the senior medical officer of the ship.

Medical stores on the Atlantic seaboard are drawn directly from the Naval Laboratory at New York, and are taken on board as soon as possible after the vessel has been put in commission.

The engineer's yeoman, pay yeoman and apothecary are the petty officers who act as store-keepers in their respective departments on board ship.

The Equipment, or *ship's*, yeoman, has charge of the articles in the general store-room.

CHAPTER XIII.

BOATS.

There are three different methods of building boats, namely:-

1st. The **Carvel-built**, which have fore-and-aft planks, the edges meeting but not overlapping.

2d. The **Clinker-built**, also fore-and-aft planks, with the edges overlapping each other, like shingling.

3d. The **Diagonal-built**, having, as the name implies, their planking running diagonally, the inside planks running in a contrary direction to the outside ones, and their edges meeting.

Boats are *single* or *double banked*, as they have one or two rowers to a thwart.

The seats for the crew of a boat are called the *thwarts*; the strips running fore-and-aft, on which the thwarts rest, the *rising*; the space abaft the afterthwart, the *stern-sheets*, and forward of the foremost thwart, the *fore-sheets*; the spaces in the wash-streak for the oars, the *row-locks*.

The *frames, knees, hooks, stem* and *stern* posts of boats are generally of oak, and the planking of cedar.

Oars are made of ash. The flat part of an oar which is dipped in the water is called the *blade*, and that which is inboard is termed the *loom*, the extremity of which, being small enough to be grasped by the hand, is called the *handle*.

The oars are said to be double-banked when there are two men rowing at each oar.

Oars should be neatly marked by the carpenter, and the men not allowed to deface the looms.

In the navy, boats are classed as follows:

Steam launches and steam cutters, frequently built of iron or steel.

Sailing launches, barges, cutters, whale-boats, gigs, and dingies, built of wood.

To Find the Weight of Boats, multiply the square of the breadth by the length, and that product for a launch, by 2.5 ; first cutter, by 1.9; quarter boats, by 1.0; second cutter, by 1.4; stern boat, by 1.0. Answer will be in pounds.

Length Of	Wabash	Lancaster	Ticonderoga,	Iroquois	Yantic	
	and Class	and Class	Plymouth and Class	and Class	and Class	
	Ft.	Ft.	Ft.	Ft.	Ft.	Ft.
Launches	34	34	32	32	30	28
Steam-cutters	33	33	33	33	-	-
First cutters	30	30	28	28	26	26
Second cutters	28	28	28	26	26	24
Third cutters	28	28	26	26	26	24
Fourth cutters	26	26	26	-	-	-
Whale-boats	29	29	29	27	27	27
Barges	32	32	30	-	-	-
Gigs	30	30	28	28	28	-
Dingies	20	20	18	18	18	18

Launches Breadth=Length x .282. Depth=breath x .40.
 Steam Cutters. Breadth=Length x .260. Depth=breath x .46.
 Cutters. Breadth=Length x .258. Depth=breath x .37.
 Barges. Breadth=Length x .225. Depth=breath x .37.
 Gigs. Breadth=Length x .185. Depth=breath x .37.
 Whale-boats. Breadth=Length x .210. Depth=breath x .39.
 Dingies. Breadth=Length x .265. Depth=breath x .37.

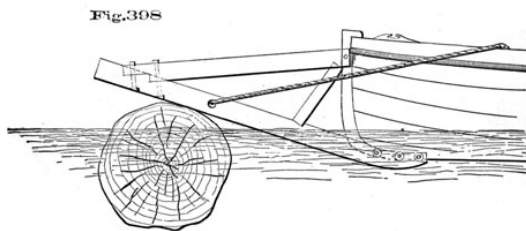
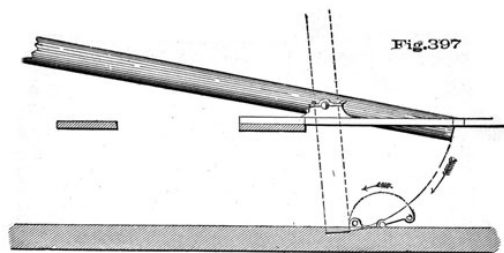
Boat Equipments. Before entering upon the detail of a boat's outfit, the following articles may be mentioned as *indispensable at all times* to every boat, viz.:

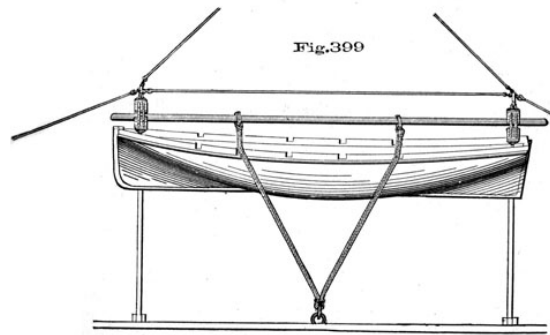
- 1st. The plug.
- 2d. A breaker of water.
- 3d. A rudder which cannot be unshipped without cutting the rudder rope.
- 4th. The boat-hooks and the oars, or the sails and spars or both.
- 5th. A bailer.

The plug should be secured to the keelson by a good laniard. The water breaker should have the bung fitted with a spigot, or faucet, and laniard and the bunghole with a leather lip. If a steering oar is used instead of a rudder, it should ship in a patent crutch, narrowing at the top, from which the oar cannot be disengaged without hauling it through, loom first, until the blade is even with the crutch opening.

Rudders are usually supplied with the pintles of equal length. It will save a great deal of trouble if a small piece of the upper pintle is cut off. Otherwise, if there should be occasion to unship the rudder, it will be very difficult to ship it again in muddy water, or with any motion on the boat, since both pintles have to be pointed at once if of the same length.

Plate 82





201

In addition to the complete set of oars, there should be two spare oars, triced up under the thwarts. A painted canvas sail cover is usually provided for the sails.

Next to the above-mentioned articles may be enumerated the following as important in the ordinary outfit of a boat, namely: a full set of stretchers, a set of boat-hooks, a good arrangement for hooking on. This should consist of short chain slings shackling to a ring-bolt in the keelson forward and aft, and to rings in the stem and stern posts; "hooks" in these spans and rings in the lower block of the tackles to avoid the danger of the tackles hooking under the gunwale or thwarts are valuable, but seldom fitted. A short and a long (stout) painter for towing or mooring are also required.

If the lower blocks are to be close to the stem and stern of the boat, it is essential that the ring, shackle, ball-toggle or other arrangement used, shall permit the lower block to be *above* the gunwale of the boat and clear of it. This avoids fouling, which is always objectionable and may be dangerous.

Additional when at sea: Gripes, Fig. 399, fitted with slip-hooks; a boat-rope leading from the fore chains and secured to the boat's bows; life-lines hanging from the boat-davit span, the supply-box provided for by the Ordnance Manual, and, when hoisting in a sea-way, two small spars to act as skids in keeping the boat clear of the chains, &c.

A boat binnacle is to be kept trimmed and at hand ready for any boat requiring it.

At least one boat in every ship should be a good surf or life-boat, and fitted for lowering and hoisting with extraordinary expedition. In this connection, it may be mentioned that the LIFE-BUOYS should be of the most approved pattern, and that the contrivance for letting them go and firing them should be frequently examined and tested.

Boats should have their own recall, and the *cornet*, and general recall, painted on a piece of tin and tacked in some secure place, *not* the backboard.

The minutiae of boat outfits for various kinds of service will be found in the Ordnance Manual.

Lowering and Hoisting (underway or in tideways). *For lowering*, boats' falls should be kept in separate racks, and always clear. A boat should not be lowered while the ship has stern-way; on the contrary, it is better if the vessel be going ahead. Should the boat get under the bows, there is danger in a sea-way of her being cut in two or stove by the dolphin-striker.

In a quarter or stern-boat the after-tackle should be unhooked first, particularly when going ahead or in a tideway, otherwise the boat may wind and be swamped.

On lowering a stern-boat in a tide-way, the moment the keel touches the water the boat is swept astern, and the

202

falls so tautened that they cannot be unhooked without much difficulty. If when the boat is hoisted we hook a stout runner, fitted for the purpose, haul taut and belay it, and unhook the regular tackles; when the boat is lowered the runner can be allowed to *unreeve* instantaneously, and the boat is swept clear of the ship at once, or swings to her painter previously made fast.

When about to lower a boat, see the line from forward made fast, put the plug in, ship the rudder (if not permanently shipped), let the men in the boat hold on to the lifelines, and keep the steadying lines fast until the boat is in the water.

For hoisting, the boat should be hauled up, a careful hand steering, or dropped from the line forward and the forward tackle hooked first. It is very important that these tackles should have their lower blocks so made that they will not capsize. When the tackles are hooked the men should keep the blocks up so that they cannot unhook, by holding up the parts of the fall. Steadying lines should be used in a sea-way, leading in through the ports and well attended, with which to bind the boat, as she rises, against the skids;

the life-lines should be crossed and the boat-ropes from forward tended. Send all but four hands out and hoist away. When the boat is up, pass the bight of the stopper through the slings-the short chain-spans which go from the ring-bolt in the stem and stern-post to keelson-or through the ring-bolts and over the davit-end twice, and hitch before attempting to belay the fall.

For hoisting quarter-boats in a sea-way, there is nothing like jack-stays from the davits to set up to the bends at the water-line. A lizard is fitted to each, which travels up and down. With these, catch a turn around the thwarts, and the boat may be run up, clear of the side, without trouble.

Pass the gripes round the boat clear of turns. Have squaring marks put on the falls, so that she may always hang square from the davits, and in port, level with the rail. If there be no scuttle which opens of itself, take the plug out the moment the boat leaves the water. Make fast the boat-rope from forward to the bows of the boat, stop it up to the chains with a split yarn. See that the fenders are in, fill the water-breaker, and if the weather be hot, put the cover or awning on square and smooth during the day, taking it off at night.

In a stern-boat in a tide-way, or ship going ahead, do not attempt to haul across the stern or hook the stern-tackle until all is ready on deck, and then hold hard by the life-lines, for the boat will suddenly fly forward as she leaves the water. The spanker out-haul, or a whip from the boom-end, will guy the boat off the ship's rudder.

Much trouble in rounding up or overhauling down boats'

203

falls is avoided by hooking the blocks to small beackets worked into staples or eye-bolts in the bends.

Handling Boats under Oars. The following orders are used by officers or others in charge of boats. A cutter, for example, is supposed to be lying alongside, properly manned, and ready to shove off:

Up Oars!

The crew, with the exception of the bowmen, seize their proper oars, and, watching the stroke oarsman, raise them briskly to the vertical, simultaneously, holding them thus directly to their centre fronts, blades fore-and-aft, those on starboard side with right hand, those on port side with left hand, down and grasping handles; the oars to be held by the hands alone, *not resting on the bottom of the boat*; the men face square aft, and pay strict attention to the coxswain.

Bowmen stand up, facing forwards, and attend the painter or heaving-line, or handle boat-hooks, as case may require. (They should not raise their oars until the order "Let fall" has been executed.)

In a sea-way, or strong tide-way, the after-oarsmen do not raise their oars at this command, but assist with boathooks in shoving off, and raise their oars together and before the order "Let fall."

At command:

Shove off!

Bowmen cast off painter or heaving line, handle boathooks, and shove the bow clear by a vigorous shove, the coxswain seeing that the ensign-staff and quarter go clear of gangway.

When the boat is sufficiently clear of the ship or wharf, the order is given:

Let fall!

The oars are to be *eased down* into the rowlocks simultaneously, and leveled. The blades should not be allowed to splash in the water. The fenders are then taken in, and the starboard stroke-oarsman gives the stroke. As the style of the stroke depends upon the after-oarsmen, they should be the best men in the boat.

In double-banked boats each man is responsible for the proper handling of his own fender. In single-banked boats No. 2 takes in and throws out the fender of No. 1, No. 3 that of No. 2, &c.

(The boat can now be pointed in the desired direction by directing the proper oars to be backed or given way upon.)

The bowmen, having shoved the boat clear, turn aft, take their seats, and lay in their boat-hooks together, and, having hauled in and coiled down the painter, if adrift, seize their oars, and, looking at each other, throw the blades over the bows, in line with the keel, simultaneously;

204

when the looms and handles are grasped, the oars are raised vertically together, and dropped simultaneously into the rowlocks. When the boat is properly pointed, the coxswain commands:

Give way together!

The starboard after-oar gives the stroke, the others follow him. Each oar should be lifted as high as the gunwale, and feathered by dropping the wrist until the blade is flat. When the blade is thrown forward as far as the rowlock will admit, it is then dropped into the water, easily and without splashing. (Rowing hand over hand, or from the shoulder alone, should never be permitted.)

On approaching the desired place of landing, the boat being properly pointed, at the moment the oars are leaving the water the coxswain commands:

In bows!

The bowmen, closely regarding each other's motions, take one stroke, and tossing their oars, simultaneously, raise them vertically, lightly touching the blades together, letting them fall into the boat together, in line with the keel, without unnecessary noise, and pass the handles underneath the oars still in motion, taking care that their oars are "boated." They then seize their boat-hooks, face forward, and, standing up, hold their boat-hooks vertically.

When with sufficient headway to reach the desired place of landing, the command is given:

Way enough!

As before, the command is given *while the oars are in the water*. The crew, regarding the motions of the stroke-oarsman, give one stroke* and toss their oars simultaneously, raise them to a *vertical position*, and lay them easily and without noise into the boat, in line with the keel. The oars to be so placed in the boat that they can be readily resumed by the crew, the stroke oars to be placed nearest the gunwale, and the others in succession.

The oars being boated, the stroke oarsmen handle their boat-hooks, keeping their seats, and assist the bowmen in bringing the boat to the landing.

After boating the oars, the fenders are thrown out.

In saluting passing boats, or in stopping to hail, or to check headway, it may become necessary to lay on the oars; to do this, command-

Stand by to lay on your oars!

At this the men pay strict attention for the command-

Oars!

which is given while the oars are in the water, the stroke is finished and the blades of the oars are feathered and raised simultaneously as high as the gunwale, where they are firmly held in lines parallel to each other-on no account

* Finish the uncompleted stroke and give one full stroke additional.

are the oars to be permitted to touch the water or to be thrown out of line.

At the order-

Give Way!

the pulling is resumed, each man regarding the stroke-oars, and taking the stroke from them.

To toss oars, the command is given

Stand by to Toss!

At the command

Toss!

which is given while the oars are in the water, the stroke is completed, and the oars then thrown up to a vertical position simultaneously, blades fore and aft, each oar is held square to the front of the man holding it-on line with the centre of the body.

In going alongside of a strange or foreign vessel to deliver a message or order, requiring but a few moments to give or execute, and particularly when it is desired to keep the crew at their thwarts, it is recommended to give the order *Toss*, rather than *Way enough!* The crew to keep their oars up while the duty is performed by the midshipman in charge. The bowmen being the only men in this case, who "boat their oars."

To trail, give the command-

Stand by to Trail!

Trail!

At the second order the oar is to be thrown out of the rowlock, and allowed to trail alongside, either by the trail line or by holding it by the handle.

To stop the boat's headway, order:

Oars!

Followed by

Hold Water!

And if necessary-

Stern all!

At the first order, lay on the oars as directed; at the second, drop the blades in the water to check the headway; and at the third, pull backward, keeping stroke with the after-oars. The oars should not be dropped into the water too suddenly, lest they get broken.

To turn a boat suddenly, order, *Give way starboard* (or port), *back port* (or starboard), *Oars!* Both backing and pulling oars should always keep stroke with the stroke oar of their own side, all oars taking and leaving the water together.

The following are given as the indications of a good stroke:

1. Taking the whole reach forward and falling back gradually a little past the perpendicular, preserving the shoulders throughout square, and the chest developed to the end.

206

2. Catching the water with the lower edge of the blade inclined *forward*, and beginning the stroke with a full tension on the arms at the instant of contact.

3. A horizontal and dashing pull through the water as soon as the blade is covered, without ever dipping more than the blade.

4. Quick recovery after feathering, the arms being thrown forward perfectly straight at the same time as the body, the forward motion of arms and body ceasing together.

5. Equability in all the motions.

Sculling with a single oar should be taught.

Boat-rigs. Plate 83. Men-of-war boats are usually rigged as follows: Launches are sloop-rigged, with a jib and mainsail. Cutters and Whale-boats are rigged either with two sliding gunter-sails or two lug-sails; the former boats have a jib in addition.

A sliding gunter-mast, Fig. 401a, consists of two sections, nearly equal in length, called the lowermast and topmast; the latter slides upon the former, and is held in position by means of two metal rings secured to the topmast near its lower end. The topmast is on the after side of the lower mast. The sail is bent to the topmast and to metal hoops on the lower mast. Make sail by hoisting the topmast, which carries the head of the sail with it, hauling aft the sheet. The mainsail has a boom.

The rig is objected to for large boats, on account of the difficulty of handling and stowing the spar and sail, which are made up together.

Lug-sails are either *standing* lugs, *three-quarter* lugs or *dipping* lugs.

The halliards of a standing lug, Fig. 402, are bent to the yard a little inside of the forward end; the tack hooks, or is lashed, *abaft* the mast.

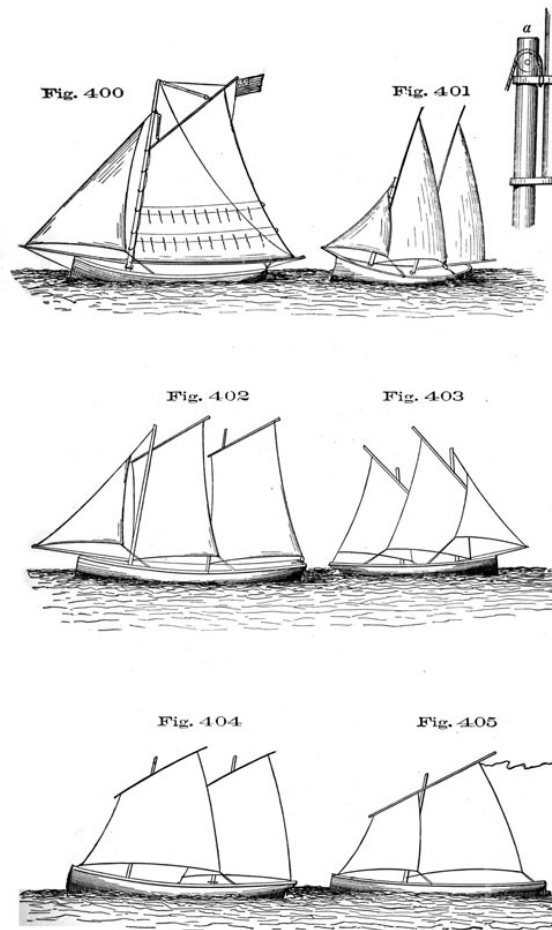
The halliards of a three-quarter lug, Fig. 403, are bent to the yard at one-fourth of its length from the forward end, the tack hooks a short distance forward of the mast to an eye in the fore-and-aft batten.

In a boat having two such lug-sails, it is customary to hoist the yards on opposite sides of their respective masts, and not to dip them. But if it is desired to dip, the sail is lowered a short distance, tack unhooked, taken round the mast and hooked again, while the *forward* end of the yard is dipped around by hauling down upon the luff of the sail. The halliards lead forward.

A regular *dipping* lug, Fig. 404, has the halliards bent at a point two-fifths of the length of the yard from its forward end, the tack hooks *well forward* of the mast, there being an eye-bolt for the fore tack on either bow.

In tacking or wearing with this rig, the *after yard* arm must be dipped around the mast from *aft* forward. This is done *in tacking*, as follows: the wind being on the (former)

Plate 83



207

lee bow, one hand lowers the halliards just enough to let the after yardarm go round the mast. This ensures plenty of back sail forward where needed, and as little slack sail as possible on top of the men. One hand forward bears the fore part of the sail out, the next two gather the clew of the sail forward and pass it around the mast, one hand aft unhooks the sheet as soon as the sail lifts, and rehooks when the clew is passed aft again. Balance of crew hand along the foot of the sail and assist in rehoisting. Shift fore tack to the weather bow.

In wearing, dip just before the wind is aft, rehoist when wind is on the other quarter. Do not allow the sails to gybe, and keep the halliards to windward.

In this connection may be mentioned the *split* lug, Fig. 405, generally used in British galleys (gigs), which have but one mast. The yard is slung at two-fifths its length from the forward end, as in case of the dipping lug, the sail is split in the wake of the mast, and furnished with a lacing, also with a second tack-lashing, or hook, for the after portion of the sail. Fitted in this manner, when the lacing is passed the sail is simply a dipping lug. With the lacing unrove and the after tack secured, the after part of the sail is used as a standing lug, the forward part (fitted with a temporary sheet) acts as a jib. The latter form of the rig is convenient in beating; the use of a jib-stay is avoided.

Dingies and gigs are usually supplied with sprit-sails-the latter boats may also have a jib. The upper end of a sprit is placed in a grommet at the peak of a sail, while the lower end ships in another grommet on the mast.

Masts should step in boxes and clamp to the thwart; clamp to be abaft the foremast and forward of the mainmast. The awkward and dangerous practice of stepping masts through a hole in the fore-and-aft batten, usually the flimsiest piece of material in the boat, cannot be too strongly condemned.

The British service rig includes an ingenious device (De Horsey's) for stepping the foremast. A stout fore-and-aft piece is fitted forward, with a slit through its centre equal in length to the distance from the heel of the mast to the partners, and in width somewhat greater than the diameter of the mast. The mast is fitted with trunnions, one on each side, resting on the after part of the fore-and-aft piece. In stepping, the mast pivots fore and aft on these trunnions. As the head goes forward and up, the heel sinks into its step, where it is confined by a pawl, which is fitted with a safety key that locks it after the heel is in place. Fig. 397, Plate 82.

With this rig the mast is stepped or unstepped in a moment. To take the mast out of the boat, unkey the cap squares of the trunnions.

The mainmast in this case is fitted in the usual way

208

with a box and clamp, the fore being given the easier rig on account of its situation, which renders it more difficult to handle.

Before stepping see the halliards are rove and that nothing will be required aloft. Never send a man aloft on the masts if halliards unreeve. Unstep the mast and rectify matters in that way.

Rigging. The masts being stepped, set up the shrouds equally and for a full due. Do not tamper with lee shrouds when sailing, to "set them up." If they are hove taut in a stiff breeze, the next tack will probably result in your wrenching the head of the mast off.

Halliards and Down-hauls. The yard of a lug-sail hooks to an iron traveler on the mast; the hauling end of the halliards should have an eye in its end, to be placed over the hook of the traveler before hoisting, and used as a down-haul.

Set a jib before setting the foresail. The jib being the fore-stay, if the foresail is set first the mast-head is dragged aft and the after leach will be slack. If obliged to set the foresail first, ease the fore-sheet while hoisting the jib, and let the head of the foremast go to its place. See the jib tack well out to the bowsprit end before hoisting.

Sails. Do not stretch the head of boat sails in bending them, unless they are bent *when wet*. Bring them to the yards and gaffs barely hand taut, to allow for shrinkage when damp, or the fit of the sail will be spoiled. See the yards slung so that the sails will set smoothly.

Boat Sailing. Make all the men who are not shoving the boat off sit down. "*Shove off*," "*in fenders*." In shoving off when the ship is not head to wind, pull clear of her before making sail. If the ship is broadside to a steady breeze you may make sail from the lee gangway, but look out for flaws.

Ship being head to wind, "*Shove off*," "*Hoist the jib*," then the foresail. If intending to sail on the wind, "hoist the mainsail" as soon as the boat is clear. If bound to leeward, let the boat pay off first to her course, then "*hoist the mainsail*," "*ease off fore and jib sheets*," and proceed.

If you want a pull on the halliards, slack the sheet; if the fore, check the main sheet at the same time.

Have the halliards coiled clear for running; do not allow the crew to stand on the thwarts or move about in the boat, nor the coxswain to let go the helm, as is sometimes done to get a pull of the main sheet, &c. By this thoughtless practice a boat may be taken aback and capsized. See that the weights are kept amidships and that all sheets are tended, not belayed.

If running and about to round to, remember that you cannot carry all the sail on a wind that you can before it, and reduce in consequence beforehand.

209

Running dead to leeward in a single-masted boat (gig) is dangerous. It is preferable to carry the wind a little on one quarter for half the distance, then haul aft the sheet, lower, shift the sail around, and head for your destination with the wind on the other quarter.

If your men are all sitting to windward in a breeze, make them take their proper places before passing to leeward of a vessel.

Steering and Trimming Boats. The "rule of the road" and the remarks about handling ship apply equally to a boat. See Chapter XXI.

Putting the rudder right across the stern deadens the way; 42° is considered the extreme of efficiency.

When there is no way on, or when the boat is tied by the stern-as in towing, when the tow-line is fast to the wrong place, the stern ring-bolt--the rudder has no effect whatever.

Always endeavor, either by trimming sails or disposition of weights, to reduce the boat to a "small helm,"

for when the rudder is dragged much across the stern the way is retarded. Weather helm will be induced by allowing the boat to be pressed by the head, and this may be caused by the bowmen sitting forward, or by press of sail, or both. If the bows are clear, a pull on the jib-sheet *might* relieve the helm, but not as a matter of course; for if the jib was already flat, it might be the cause of depression, and a few inches checked would perhaps answer the purpose. Then the main sheet might be the cause, and an inch of that sheet might be the remedy. But it will be of no use to attempt trimming until the sails are taut up and well set; and then the officer in command can make his alteration of trim, until the boat may be so nicely balanced that, by sending the bowmen forward and letting go the tiller, she will go about of herself.

If the bow is deep and the stern light of draught, the former is not so easily blown from the wind as the latter. If, on the contrary, the stern be deep, and the bow light, the bow is readily thrown to leeward by the conjoint action of wind and sea. In the first of these cases—supposing the sail to be well balanced—the boat would carry weather helm; in the last, lee helm; but in either, her way would be more or less diminished. The drag of cross helm might be decreased by reducing sail at one of the extremities, but at the expense of speed; whereas, by *trimming weights*, all sail might be carried, and speed increased.

Use water in breakers for ballast.

Tacking. Having previously described the method of dipping lugs, let us assume the boat to be a cutter fitted with jib and sliding gunters. Keep a good full for stays, then "*Ready about,*" the helm is *eased* down, then "*ease off the jib sheet!*" if the boat is a slow worker and does not

14

210

come to readily, otherwise the jib sheet may be kept fast. Haul the main-boom handsomely amidships. When head to wind shift over the fore sheet, be careful not to make a back sail of the foresail. Bear the jib out to windward to assist in paying the boat's head around. When the jib has paid the head off sufficiently to fill the foresail, "*draw jib,*" hauling aft the jib and fore sheet, *right* the helm, haul aft the main sheet.

If the boat gathers stern-board shift the helm; get out an oar on the lee bow to bring her head around, or let all the crew that are in the after part of the boat place themselves on the (old) weather quarter, the boat will then pay off the right way, owing to the pressure of the water being more on the immersed quarter than the other.

Thus, if the boat is head to wind and her bow ought to pay off to *starboard*, send the men who are aft to the starboard quarter, their weight depressing that quarter the bow will pay off as desired.

Men-of-war boats fitted with but one sail (unless a split. lug) should not attempt to beat to windward.

In working to windward among shipping, or in a harbor, if there is any doubt of your weathering a particular object, it is always safest to tack. In luffing up for a "half board" a boat quickly loses her way and becomes for the time being unmanageable. This would probably result in your fouling the danger you have tried to avoid.

Wearing. Put the helm up, "*ease off the main sheet!*" or, in a fresh breeze, "*brail up the main-sail!*" Slack off the fore and jib sheets as she goes off; when the wind is well on the quarter, "*shift over the fore sheet!*"; with the wind on the new weather quarter set the mainsail, or, "*haul aft the main sheet,*" then the fore; when nearly by the wind, *haul aft the jib sheet* and *right* the helm.

Instead of lowering the main-sail altogether, it is sufficient to "*brail up,*" hauling aft the sheet again as soon as the sail will take on the new tack.

Under Sail and Oars. When the wind fails, get out oars and keep the boat under oars and sail as long as the latter are of any assistance. If the breeze freshens again, lay in at least the lee oars to avoid catching crabs and splitting the gunwale. When the weather oars barely strike the water, in consequence of the boat's inclination, it is time to lay them in also. Ship rowlock shutters, if used.

Heaving-to. Put the helm down, haul the main-boom well over amidships, the jib-sheet to windward, *brail up* the fore-sail.

Reefing. Before reefing, tell off the men for the different duties; using lug sails, two men forward haul down on the luff of the sail and shift the tack, one hand by the halliards, one at the downhaul, one to tend the sheet,

211

the rest tie the points and shift the sheet-block at the clew. Do not luff, check the sheets, lower enough to tie the points, hauling in the fore-sheet so that the men can get at the foot of the sail without reaching over the lee gunwale; shift the tack and sheet, and tie the points; slack the sheet, hoist and haul aft.

Hoist the foresail *first*, or if the mainsail be first hoisted, check its sheet till the boat has headway, or she will get in the wind and lose time. Reef a sliding gunter in the same way, except that there is no need of a downhaul, nor of hauling down upon the luff of the sail.

In reefing, do not roll up the foot of the sail snugly; it holds more water than when the sail is loosely tied up by the points.

Always begin to reef when the boat commences to bury her lee gunwale or shows signs of being crank.

In reefing, or performing any of the evolutions described, nobody needs to stand up. Good boatmen never jump about on the thwarts, or show more than their heads above the gunwale.

Squalls. Sailing *on a wind*, in *moderate* squalls, ease the sheets enough to relieve the boat, keep enough steerage-way to bring her promptly into the wind if the squall increases.

When caught in a *hard and sudden squall*, put the helm down at once, let fly the fore-sheet; and as such squalls frequently veer more or less, lower the sail; for if it catches aback there would be difficulty in getting it down, danger and sternway from keeping it hoisted.

Sailing *with the wind abeam*, if a squall comes up, receive it with the sheets flowing and halliards clear for running.

The squall increasing in violence, brail up the mainsail, up helm, and if need be, lower and reef the foresail.

If obliged *to run before* a very fresh breeze, use a reefed foresail, but in any case carry enough sail to keep ahead of the sea.

An empty breaker, or spar towed astern, will much diminish the danger of being pooped.

Caught in a Gale. If blown out to sea, or otherwise unable to reach the ship in a gale of wind, lash your spars, sails, and all but half a dozen oars, together. Make a span of the heaviest rope available. Bend the span to the opposite ends of the largest spar, bend the end of your painter to the span and launch the spars overboard; the longer the scope the easier the boat will ride, to the breakwater thus formed. The sails should be loosed on attaching their yards to the spars, they will thus contribute greatly to breaking the sea. If weights be fastened to the clews the boat's drift will be much retarded.

Capsizing. As a rule, remain by the boat-she will

assist those that cannot swim to keep afloat, and those who can swim may, with the aid of the boat, render valuable assistance.

Taking in Sail. *To take in the jib*, foresail being set, slack the tack and gather in the sail on the foot, lower the halliards. If the foresail is not set, lower the halliards first, gather in on the after leech and foot; when down, let go the tack.

To take in a lug-sail, check the sheet, haul down on the downhaul and luff of the sail at the same time; do not haul on the after leech, as it causes the fore-part of the sail to fill and the traveller to bind against the mast.

With sliding *gunter* sails, lower the halliards, then brail up.

Going alongside. If under oars, a fresh breeze blowing, pull, as a rule, for the lee gangway. Boat the oars instead of tossing them, whether going or coming, whenever there is any considerable motion, as they are apt to take under chains, ports or other projections from ships or wharves.

If *under sail in a fresh breeze*, always get down the masts before coming alongside. Round to ahead, down masts, out oars, and drop down; or shoot up under the stern, and down masts before getting under the quarter boats.

Ship head to wind, no tide, get the main-yard end on, keep the boat away a little to allow for rounding to, "*down jib*," and rig in the bowsprit in good season; when with way enough, "*brail up the foresail*," put the helm down, haul flat aft the main sheet, brail up the mainsail as soon as it ceases to draw, out fenders.

If there is any current, make allowance for it by heading for a point further forward or aft, as the case may be.

Riding to a windward tide, if approaching from abaft the beam, the foresail may be taken in and mast unstepped, using the mainsail only to bring her alongside. Approaching the ship from forward of the beam, unstep masts and out oars.

Whenever there is the slightest doubt of your ability to fetch the gangway under sail, brail up, unstep the masts and pull alongside.

Always unstep the masts in approaching a vessel under way, and do not board, or shove off from, a vessel which has sternway on.

If unable to fetch the ship in a strong tideway or fresh breeze, keep as much as possible in her wake. The ship will veer astern a buoy or small boat bearing a line by means of which the boat can be warped up alongside.

Under similar circumstances the gangway being unshipped (River Plate, Canton River, &c.), a small hawser may be carried around the ship outside all, the bight made

fast to the bowsprit cap, the ends reaching the water astern and the hawser suspended on both sides from each lower yard-arm by whips with bowline knots.

The hawser is triced up clear when not in use, and dropped in good season as a boat rope for approaching boats.

In going alongside a ship riding to her anchor, or underway, round to so that bow of the boat will be in the same direction as the ship's head.

But if a vessel is moored head and stern, approach her by rounding to *head to the current*.

THE DISPOSITION AND USES OF MEN-OF-WAR BOATS.

The steam launch and sailing launch hoist inboard, or are carried on the rail.

Barges and cutters hoist in the waist forward or abaft the gangways, or there may be enough cutters to require all four sets of davits in the waist; the barge, whale boats, and an additional cutter hoisting to two sets of double davits on the quarters; gig and dingy hoisting astern; the latter may be stowed on board in one of the launches.

The steam launch is used in towing, transporting stores and for passengers.

The sailing launch and the larger cutters are employed in all heavy work, carrying out anchors, watering and provisioning ship.

Barges are for the use of flag officers, and are supplied only to flag-ships.

Gigs are for the use of commanding officers. Whaleboats are used as life-boats or for answering signals, &c.

Dingies are used in conveying stewards and servants, or for other light work.

The cutters not reserved as working boats are the "running boats" of the ship for transporting passengers and other general duties.

In Port, nothing sooner indicates the order and discipline of a man-of-war than the clean state and efficient condition of her boats. The coxswains of the regular running boats for the day should clean and have them ready for lowering at the proper time, usually at morning colors.

When boats are lowered, they are hauled out and secured to pendants at the lower booms, fenders out; gigs and dingies are secured to the stern pendants.

Every boat when down should contain a boat-keeper the duty being taken by the members of the boat's crew in turn. Usually in a cutter, the men who occupy the same

thwart are detailed for one day, the next thwart taking the duty on the following day.

A boat-keeper is to keep his boat clear of others, to haul it up to the boom for manning, and to haul forward clear of the gangway when other boats come alongside or shove off.

Boat-keepers rise and salute all commissioned officers passing, leaving, or going on board the ship.

To keep a boat clear of a ship when riding astern, let her tow the boat-bucket.

In blowy weather heavy boats are moored at the boom with a hawser led through a block on the boom to another on the bowsprit, thence inboard. This relieves the spar of much strain.

A launch may be hoisted out of water overnight or to scrub her bottom, by using the cat and a stout purchase to the bowsprit. If hoisted for scrubbing, send the hands under her in the catamaran.

The crews of running boats should wear their neck handkerchiefs, shoes and cap-ribbons, and be mustered for inspection every morning by the officer of the deck.

Boats should be manned from the booms or stern pendants if moored there. Three minutes is a fair allowance of time for manning a boat and bringing her to the gangway.

Boat Salutes. Boats not laden nor engaged in towing, when meeting or passing other boats, observe the following ceremonies:

To a boat with the flag of an admiral, vice, or rear-admiral, or the broad pennant of a commodore, boats with a narrow pennant, and those containing staff officers of the relative rank of commanding officer, are to lie on their oars or let fly their sheets, and boats without pennants are to *toss their oars or lower their sails*.

All officers meeting their own immediate commander with his pennant flying, will salute by *lying on their oars or letting fly the sheets*.

Officers inferior in grade to any other commanding officer than their own salute also as above, lying on their oars or letting fly the sheets.

The coxswain salutes all commissioned officers by standing and raising his cap, and salutes warrant officers by raising his cap only.

The officer to whom a salute is tendered should promptly acknowledge the same by raising his cap, and in all cases the salute by raising the cap is mutually made, but first by the junior in rank or seniority.

The officer and coxswain of loaded boats, and boats engaged in towing, salute a flag officer by standing and raising their caps; in all other cases the boat officer salutes by raising the cap only. (See U. S. Navy Regulations.)

215

Give the preparatory order in good time, and when at such bearing and distance that the salute can be best observed, give the order of execution; permit the boats to pass before resuming the stroke, hoisting, or hauling aft.

The officer of the boat and coxswain salute at the same time of saluting with the oars or sails.

Instead of tossing, single-banked boats trail their oars.

A junior should never pass his superior officer when pulling in the same direction, except when on urgent duty.

When boats are approaching the same landing or vessel, an inferior is always to yield the way to a superior in grade. Boats about leaving the ship's side with inferiors are to give way in ample season to others approaching it with superiors.

In stepping into a boat the junior goes first, and remains standing till the senior is seated; in leaving a boat the junior remains until after the senior has disembarked.

Duties of a Boat Officer. When ordered to take charge of a boat, report promptly to the officer of the deck, dressed in the uniform of the day, and with side arms. If there is no midshipman of the quarter-deck, see the boat lowered and manned, or manned and dropped to the gangway from the boom. See the crew in uniform, coxswain in, oars up, blades fore-and-aft.

Receive your orders, and be sure that you understand them perfectly before leaving the ship, and also assure yourself that all necessary articles are in the boat.

Having received your orders get in the boat, shove off and let fall.

If going to another man-of-war use the port side, except when there are commissioned officers in the boat, or when the starboard ladder only is shipped. Salute the quarterdeck on stepping over the gangway, and report to the officer of the deck. When ready to leave the ship, request the officer of the deck to have your boat manned, instead of giving orders yourself. When your boat is ready, report your departure.

If in a tideway, and likely to be detained on board for some time, request permission for your boat to hang on at the boom; do not allow your men to come on board without permission from the officer of the deck.

If advisable, for any reason, order the coxswain as you leave the boat to shove off and lie off the ship.

Preserve silence and order at all times in your boat, see that the men pull properly, or, if sailing, that the sails are handled in accordance with the foregoing instructions.

When a boat officer must be absent from his boat, he should leave his coxswain in charge, with positive orders concerning his duty.

Pulling in for a landing among a crowd of boats, *lay*

216

on your oars at a reasonable distance from the wharf, instead of boating your oars at the last moment. This leaves you control of the boat, and you can *back* or *give way* as may be needed to avoid collision, instead of dashing in, breaking oars and boat-hooks, and may be staving your own boat. *Boat the oars* when no longer needed.

Make due allowance for the rate at which the tide is going past a ship, or the rate at which she may be moving, when making for her. A current frequently sets close along the shore in the opposite direction to the one that is going by the ship; and, therefore, a little judgment may save a long pull. An inquiring boat officer will learn more of the local tides and currents by a chat with a water-man than can be found in books; and by observing the manoeuvres of native boatmen much labor and risk may be avoided.

When practicable always keep out of the strength of a contrary tide.

Avail yourself of every opportunity for steering by a *range*, as there are many coxswains who cannot steer a straight course athwart a strong tide.

If conveying on shore a person entitled to a salute, work up ahead of the ship if practicable, lay on your oars, flow your sheets, or stop the engine (as the case may be) at the first gun, and proceed after the last gun is fired.

A boat officer has charge of the boat, but when carrying commissioned officers the senior line officer has authority to interfere, and if need be to take command.

Never attempt to cut across the bows of a boat containing commissioned officers. Be on the alert to give the proper salutes to all officers in passing boats of whatever nationality, and be particular that the coxswain salutes *all* officers, and rises to salute commissioned officers.

The boat officer does not rise to salute, except when in a laden boat he passes a boat flying the broad pennant of a commodore, or the flag of an admiral.

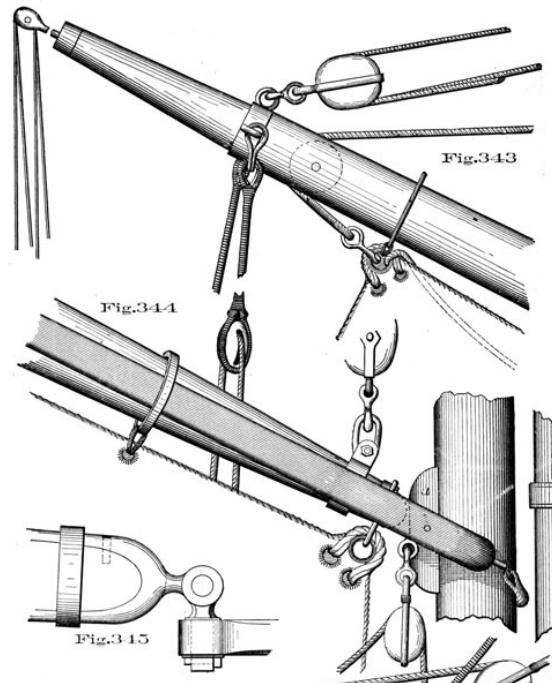
At night, in thick weather, or when far from land, do not leave the ship without a compass; and get the bearing of the place to which you are bound *before* starting. Take a bearing of your own ship also *before losing sight of her*. It has been found very convenient to keep a supply box always in each boat, containing a pistol, flash-pan, powder, caps, a rocket and blue light, hatchet and a few nails, &c. (See Ordnance Manual.)

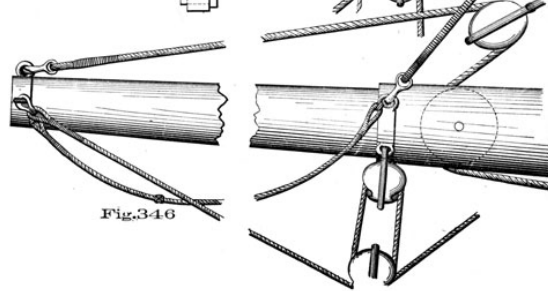
A boat officer is always supposed to have his watch and boarding book at hand.

When ordered on boat duty, it is well to remember your men's meal hours, either taking the provisions in the boat, or warning the master-at-arms that the crew will be absent.

Acquire the habit of sitting down in a boat, and never

Plate 64





217

stand up to perform any work which may be done sitting.

Always step at once into the midships of a boat in getting into one, and never on the gunwale.

The boat should be baled out, slings hooked, and otherwise prepared for hoisting, before reaching the ship, if intending to hook on.

In boarding a merchant vessel fill out the columns of your boarding book. If sent on board a man-of-war to offer services, &c., keep any information acquired for insertion in your book after leaving the vessel.

Finally, bear in mind at all times the following points:

Keep a boat bows on to a heavy sea.
 Never jamb a helm down too suddenly or too far.
 Keep your weights amidships.
 Never belay the sheets.

Being Towed by a Vessel. If *alongside*, have the tow-rope from as far forward as possible, never make it fast, but toggle it with a stretcher to the forward thwart, steadying it over the stem with the bight of your painter, or pass it through the foremost rowlock on the side nearest the ship. Fig. 407.

When towing *astern*, the closer the better. In casting off, if there are other boats towing astern, either be dropped clear of them all, with your tow-line, before letting go, or be handy with your oars to avoid getting athwart-hawse of some of them.

Do not permit other boats to hold on to a vessel by your boat. Get more of your own tow-line, steady it over the stem and stern with slip lines, and pass the end into the next boat astern. Fig. 406.

Towing. In taking another boat *in tow*, pass clear of her oars; place yourself right ahead, exactly in line, and give way the instant that you have hold of her painter. Do not give another boat your painter until she is in line ahead of your boat. Toggle the tow-line between the two after thwarts with a stretcher. Toggle your own painter to the forward thwart before giving it to a boat ahead. This saves the stem and stern-post. If you wish to turn your boat's head, bear the tow-line over the quarter on that side to which you desire to turn, for the helm will be of little or no use.

In towing short round, do not attempt to turn before your leaders are around.

The heaviest boats should always be nearest the tow.

Boats will tow with increased effect if weighted with shot. A few lengths of stream chain is the quickest weight that can be passed in and out, besides being less damaging to the boat.

Taking another boat in tow without delaying the duty by fouling her oars, or the boat itself, is a very neat

218

performance, and, when well done, betokens judgment and skill.

Tow spars by their smaller ends.

A steam-launch being frequently used in towing may be fitted with a span of wire rope, the ends being secured to either quarter and with a good-sized thimble in the bight to receive the tow-line. The steering is rendered much easier by the use of this span.

Towing Fire Ships, or Vessels on Fire. When boats are sent on this service, provide them with a few lengths of small chain, to make fast to the burning vessel; grapnels would do well to throw on board, and then make fast the tow-rope to the chain of the grapnel, for the boats to tow from. There are many instances of towropes and hawsers being burnt when employed on this service, and other vessels much endangered from want of this precaution. If hawsers are sent to be made fast to a burning vessel, with the intention of warping her clear of other vessels, using a length of stream-chain cable for the bending end will be found much safer than trusting to rope alone.

Boarding a Wreck or Vessel in a Heavy Sea. Whenever practicable, a vessel, whether stranded or afloat, should be *boarded to leeward*, as the principal danger to be guarded against must be the collision of the boat against the vessel, or her swamping by the rebound of the sea, and the greater violence of the sea on the windward side is much more likely to cause such accidents.

In boarding a stranded vessel on the lee side, if broadside to the sea, the chief danger to apprehend is the falling of the masts or the destruction of the boat amongst the wreckage alongside. Under such circumstances it may be necessary to take a wrecked crew into a life-boat from the bow or stern.

Large life-boats used on flat shores or shoals, usually *anchor to windward* in boarding a wreck, and veer down from a safe distance until near enough to throw a line on board.

In every case of boarding a wreck or a vessel at sea, it is important that the lines by which a boat is made fast to the vessel should be of sufficient length to allow of her rising and falling freely with the sea, and every rope should be kept in hand ready to cut or slip in a moment, if necessary. On wrecked persons or other passengers being taken into a boat in a sea-way, they should be placed on the thwarts in equal numbers on either side, and be made to sit down, all crowding and rushing headlong into the boat being prevented as far as possible; and the captain of the ship, if a wreck, should be called on to remain on board her to preserve order until every other person shall have left the ship.²¹⁹

219

An exception to the usual rule of boarding to leeward occurs in the case of a vessel of very low free board, such as small schooners, &c. Board such craft on the *weather quarter* to avoid being stove by the vessel's main-boom, or chains, &c.

Warping. A warp is a rope or a hawser employed occasionally to remove a ship from one place to another in a port or river.

To warp a vessel is to change her situation by pulling her from one part of a harbor to another, by means of warps which are taken to other ships, buoys, or certain stations on shore. The ship is then drawn forward to those fixed points, either by pulling on the warp by hand, or by application of some purchase, as a tackle, or capstan.

Wet warps require careful seizing. Make four parts of a spun-yarn seizing, take a round turn with the bight of this round the standing part of the warps, then pass the seizing (figure of eight fashion) round the hitches and standing part, then cross opposite ways with two parts each way, reeve the ends through the bights and drag all the turns taut.

The quick way to run a short warp out, is for one, boat to run away with the end, and the others to pull in fore-and-aft under the bights, as they are payed out at equal distances, according to the length of the warp and number of boats, giving way the moment they have got hold.

In all cases when you take in the end of a warp, coil enough of it forward so as to be able to make a bend the instant your boat reaches the place where you wish to make fast.

It is hardly possible to lay a heavy warp out without floating its bight. If there is a chance of its being suddenly tautened, hang it outside the boat instead of laying it fore and aft amidships.

A Guess Warp. To lay out a warp to *windward*, or against a tide, coil the whole warp in the boat, pull to the place assigned, make fast and drop down to the ship.

To lay out a warp to *leeward*, or with the tide. Take most of the warp in the boat, let the ship pay out more after the boat has shoved off, until what is in the boat is sufficient, then pay out from the boat to the make-fast. Whichever way it be, there is great judgment required in reserving a sufficiency of hawser in the boat to insure that she will reach her destination, only paying out when certain of doing so. It is from this necessity for judging the distance by the eye that we have the term "guess warp."

When you are given the end of a hawser to run out which is not becketed, put a hitch on it and stop the end down at once.

220

Kedging. When the operation of warping is performed by the ship's kedges, these, together with their warps, are carried out in the boats alternately, towards the place where the ship is endeavoring to arrive, so that when she is drawn up close to one, another is carried out to a sufficient distance ahead, and being sunk, serves to fix the other warp, by which she may be further advanced; the first kedge is then weighed, sent ahead, and the operation repeated. This is commonly called *kedging*.

When great expedition is required, the boats should be equally divided into two parties, the light boats towing the larger containing the kedge and hawsers. As soon as the first kedge is let go and the ship started ahead, the other set may "pay and go," so that when the first is at a "short stay," the second may be let go, and the ship thus kept going continuously.

The evolution of kedging was practised on board the Constitution, during the exciting chase in which she escaped from the British squadron, under Sir Philip Broke.

There are many cases when kedging might be necessary to modern vessels if disabled or not under steam.

Carrying Stores. When provisioning ship, be careful with the oars, as the blades are easily ruined by throwing them on stones or by treading on them; keep all casks "bung up," and leave space under the afterthwart for baling the boat out. Have tarpaulins for covering bread or anything that will be injured by salt water. Sling the midship casks as they are stowed. While loading, make large allowance for the roughness of water you may have to encounter.

Do not overload a boat, particularly with men or sand; the former may be attended with loss of life; in the latter case, it must be remembered that sand is much lighter when dry than wet. Be prepared to buoy treasure if carried.

A laden boat carries her way longer than a light one, therefore shorten sail or "*way enough*" in good time.

Boats taking in water in bulk. The launch, or largest boat you intend for the purpose of watering, must be cleared of all her gear of every description; then tow or pull her to the watering place, where she must be well washed out with water several times, until perfectly clean; when done, put the hose into the boat, and merely leave a couple of hands to attend it until the boat is full; then, by a signal from the shore, or otherwise, send a boat to tow her off to the ship; pump the water out of the boat into your tanks, and so on until you complete your water. If in a river, pull the plug out and let her fill.

In watering from a spring, keep the end of the suction hose in a tub, or have a rag around the strainer to keep out gravel or sand.

221

Hauling up boats on shore. Before leaving the ship, see the boat's anchor and a good luff tackle in the boat. If it is a heavy boat, say a launch, take a couple of stout towlines or small hawsers as well, with additional tackles.

Run the boat's bow on to the beach, and let a few hands on each quarter keep her in that position, by setting their oars against the ground; next, sweep her with a hawser, and guy it up at the stern to a proper height by several turns of the painter; to this hawser hook on the double block of the tackle, the other end, or single block, being overhauled to a proper length, and hooked to the boat's anchor buried in the ground, with one hand on it to prevent rising. Fig. 408.

Pass the bight of another hawser round the stern post, and having guyed it up on each side to the gunwale, hook on, on each side, a quarter tackle also, overhauled to a proper length, and hooked at the other end where convenient; man these with the remaining hands; then, having placed rollers in succession to take the boat's forefoot and keel, proceed to haul away. When up, the loose thwarts set against the ground and wash-streak will keep her upright.

The loose thwarts should also be placed for the rollers to roll on if the ground is soft.

Smaller boats do not require quarter tackles, and may be hauled up by their crews if provided with rollers and tackle, as described.

Boats that are being frequently hauled up and launched should have a hole in the forefoot, through which a strap for the tackle could reeve. When the tackle is secured to the boat at the top of her stem, it buries her gripe in the mud.

To transport on land a moderate-sized boat, turn her bottom up and shoulder her by the gunwales. A heavy boat should not at any time be turned bottom up, on account of the strain.

Having hauled up boats or small vessels on temporary ways for repairing, remember that sea-weed is as good as soap on the ways, in launching.

Embarking Heavy Articles. In the entire absence of usual resources, great weights, such as a gun for instance, may be got into a boat where there is great rise and fall by filling the boat at low water with dunnage or sand, banking up an inclined plane with shingle, rolling the gun into the boat, clearing out the sand and waiting for the tide to float her off.

Get a boat under a low bridge, or under a weight that cannot be raised high enough to clear the gunwale, by taking the plug out; then replacing it and pumping out the water.

When weighing anything heavy over the stern of the

launch, bear the rope amidships and ship the awning stanchion over it, the latter being fitted with two legs, one on either side of the stern roller. This will keep the rope from flying over to the quarter and capsizing the boat.

Life-boats. In men-of-war, a boat on each quarter is designated as a "life-boat." These boats are fitted with a detaching apparatus of some one of the patterns described below, and are otherwise prepared for immediate use at sea, the other boats being topped up and more permanently secured.

There is a life-boat's crew in each watch, composed of the best seamen in it, and with plenty of supernumeraries to supply the places of men aloft, at the wheel, or sick. The coxswain of the life-boat's crew of the watch inspects *both* life-boats at sundown, sees the plugs in, towline from forward secured in place and clear, falls clear for running, gripes ready for slipping, oars in place, steering-oar pointed but clear of the after block, bag of bread, breaker of water and bucket (or bailer) in the boat, and a *lighted* boat compass at hand abaft the wheel, in charge of cabin orderly, or in some place well known to both crews. He should report to the officer of the deck, "Life-boats clear and ready for lowering."

Being in charge of the life-boat when called away, see plug in and *compass* in the boat, all the gear ready as above described; send out all supernumeraries, slip the gripes, stand by lever of detaching apparatus yourself, if worked in the after part of the boat, otherwise go to the steering-oar. Caution the bowman, who may be looking out for the towline, to keep clear of the forward block till detached.

Detach the boat in good season; some forms of apparatus will slip one fall at a time if the boat becomes partly waterborne owing to delay at the lever.

The boat being unhooked, the boat-rope should have drift enough to let you shoot out well clear of the side while being towed. Take advantage of this to have every oar rigged out and manned before letting go.

If the boat is sluggish in getting clear, shove her stern out and cast off the towline; the ship moving on, leaves you head to sea; out oars as speedily as possible.

If after a man overboard, let a cool hand watch the ship for signals and steer accordingly. On reaching the man, if he has the buoy and is not exhausted, round to head to wind before picking him up. In any case, on approaching him, trail as many oars as possible, and be careful how the remaining ones are handled; get the man aboard forward if possible, then out oars, pull ahead, and take in the buoy over the quarter.

Your vessel having run to leeward to pick you up, it will be advisable in a heavy sea to *tow* the buoy on your way back with a good scope, letting it act as a drag.

223

Pull up under the lee of the ship get your towline first, as previously described under "HOISTING." Bend your line from the buoy to another line passed from aft, and let the buoy be roused up to its proper place.

In hoisting let the men put their weights on the life-lines. When hooked on, the boat is run up smartly and without stopping, as the vessel rolls *toward* it.

When boats are suddenly lowered, in an emergency, it is very often of the highest importance that they should be provided with means of night-signalling, _ sounding, or effecting temporary repairs. The boat boxes containing the necessary articles are now usually kept in the hold. It would be better if essential articles were kept in a small locker *built in* to the boat, as is the case in other navies.

In referring to the above-mentioned boats as "lifeboats," the word is not to be understood in its literal sense, as regular life-boats are not supplied to vessels of the navy.

Small empty casks or breakers, tightly bunged and lashed beneath the thwarts, would partially convert any boat into a life-boat, by making it impossible for her to founder.

Balsas, or life-rafts, are supplied to vessels of war-being of different sizes and material, but similar in design. They consist of two cylindrical-shaped air-chambers, pointed at both ends, and supporting a platform, or raft. The air cylinders are either of wood, or made of rubber covered with canvas; in smaller forms the air-chambers are sometimes of rubber, not covered. When the air-chambers are of rubber the larger balsas are usually kept empty until wanted, when the air-chambers are inflated by means of a sort of bellows and tube.

A small form of wooden balsa is used throughout the service as a *catamaran*, or boat for the side cleaners. The small rubber balsas are excellent substitutes for life-buoys, and in many ships are slung at the quarters for that purpose. They can be used to carry lines astern or ashore, in the case of a wreck.

For management of boats in a surf see Appendix F.

HINTS FOR BOAT OFFICERS IN CHARGE OF STEAM LAUNCHES.

The following Instructions for Working the Engines of Steam Launches are introduced here, as the boat officer is not unfrequently thrown entirely on his own resources.*

* From the "Sailors' Pocket Book," by Captain F. G. D. Bedford, R. N.

The engine should not be removed from the boat oftener than can be helped. The boiler of steam launches should be lifted, examined at the bottom, and painted every month.

See that the tanks, fitted for the purpose, are properly supplied with coal and fresh water.

The connection with propellers and water-tight joints must be made good before leaving the ship.

Water is run into the boiler through a hose by removing one of the safety-valves. When the water is showing from one-half to three-fourths up the gauge-glass, remove the hose and replace the safety-valve. Great care must be taken to see the valve and its seating perfectly clean before the valve is replaced.

To get up Steam. Put a surface of coal over the fire-bars, shut the ash-pit door, and light up with wood and coal at the front until a sufficient body of fire is obtained to ignite the coal on the bars, when the fire may be pushed back, and the ash-pit door opened.

When steam begins to show by the gauge, try the safety-valves, and use the blast (if the steam be required in great haste), until sufficient pressure be obtained.

The Boiler will require the most careful and constant attention while steaming. When attainable, fresh water should always be used.

From 40 to 50 lbs. of steam pressure is quite sufficient for all ordinary service. Leaks about tubes and tube-plates are most frequently caused by forced steaming.

The water should never be allowed to go below the mark of low level.

At high speed it is liable to show higher in the gauge-glass than it really is.

The gauge-glass and gauge-cocks must be frequently tried, the one being a check on the other.

The water moving in the glass with the movements of the boat is a proof of the glass-gauge being correct.

Care should be taken to prevent spray from striking the gauge-glass, as it is very liable to break it.

Maintain a sufficient quantity of water in the boiler and keep the feed-water supply as nearly constant as possible. In the event of the water getting low the fire must be checked as quickly as possible; to effect this, open the front connection door, shut the ash-pit door, and throw on wet ashes. In an extreme case, draw the fire.

Starting the Engine. Have every fractional part of the engines carefully oiled, especially cylinders, slide-valves, eccentrics, cranks, and thrust; open the small drain-cocks in connection with the cylinders and slide-valves, to get rid of condensed water, and let them remain open for a few turns of the engines. The steam-valve may

be left a little open while steam is getting up, to warm the engine.

Starting ahead or astern is effected by link-motion, and requires no consideration after observing the movement of the handle connected with the link.

Great care should be taken to admit the steam to the engines gently at first, and get them up to their full speed gradually.

Running. Attention to the engines is required in preventing over-heating of working parts.

Any, unusual noise must be quickly attended to, and cause ascertained.

Sea-Water. If obliged to use sea-water for the feed, let the process of blowing-off be as constant and continuous as possible.

Firing. The firing must be careful, and frequent, in just sufficient quantity to keep the fire-bars properly covered; attention to this will go far to prevent priming.

Keep the steam at a regular pressure, and the fire-bars free from clinkers by hooking them out as soon as formed.

The tubes, fire-box, smoke-box, and the space at the back of the fire-bridge should be kept free and clean; this must be done as opportunity offers.

If the screw of a steam-launch is taken off for the purpose of her being used as a sailing-boat, the brass bushes, usually provided for the purpose, should be put on the end of the shaft (first coating them with white lead and tallow), in order to prevent them from the rapid galvanic action which takes place by their close proximity to the copper sheathing on the boat's bottom. If no bushes are provided, the end of the shaft should be lapped round with spun-yarn well saturated with stiff white lead and tallow.

A steam-launch should not be driven at high speed in a seaway, and her outfit should always include a few oars and thole-pins, for use in case of accident to the machinery, also life preservers; especially in iron launches.

Jumping Booms. Steam-launches are commonly fitted with apparatus for spar-torpedoes, supplied and described by the Ordnance Bureau. To enable such torpedo boats to clear obstructions in the form of booms, the fittings shown in Fig. 398, Plate 82, have been successfully used, the object being to give the bows of the boats an upward slant on striking the boom, which enables them to jump it. The engine should be stopped on striking the boom, and until it is cleared.

The form of the skeleton frame fitted forward is, of course subject to variation, depending on the shape of the stem.

15

WOOD'S BOAT DETACHING APPARATUS. (PLATE 85.)

This device consists of two slotted, hinged links, A A, whose pivoting ends are secured in or near the stem and stern of the boat. The movable ends of these links are held in a fixed position, when necessary, by lengths of small chain, which are joined by a slip hook *d*. A tripping link, E, holds the slip-hook closed. By pulling upon the lanyard, L, the slip-hook may be released, the hinged links, A, A, turn upward, and the falls, F F, are detached. Figs. 410 and 411.

The lower blocks of the falls are fitted with ball toggles, adjusted to enter the slots in the links A A. When a fall is hooked on, the tumbler, X, under the hinge, A, closes the slot and prevents accidental unhooking, whether in the case of one end of the boat being lifted by a sea in lowering, or before the falls have been set taut in hoisting.

The tumbler, X, is free to turn back to allow the toggle, F, to pass into place in hooking on, but it is then brought back immediately into place by the counter-balance on its lower end.

The ball toggles, F, may be either moused on old style of hooks, or the hooks may be removed and the toggles fitted to their places on the block-straps.

The rollers, B B, are made smaller than shown in the plate, which represents the apparatus fitted with flexible wire pendants, for which small chain is now substituted.

The enlarged figures, 412 and 413, show how the apparatus is now fitted in boats hung by the extremities, or from points nearer the centre of the boat.

In Fig. 412, *y* is an eyebolt for the boat's painter.

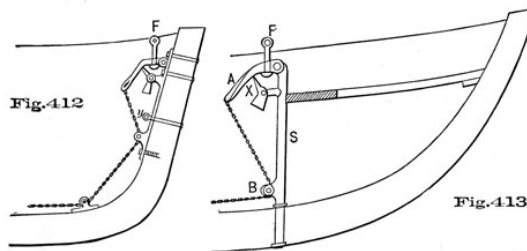
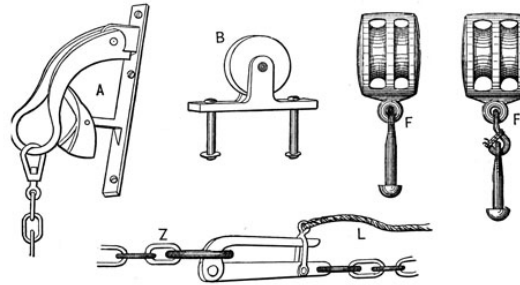
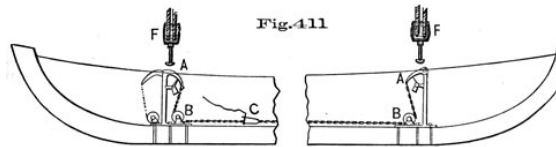
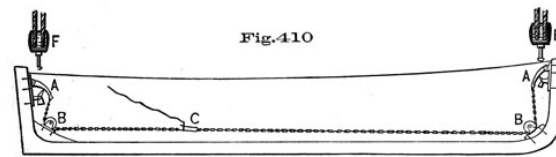
In Fig. 413 it is desirable, when possible, that the head of the stanchion, S, should be steadied against a thwart in the bow or stern sheets.

After the apparatus is fitted in the boat, the chain is taken up to the proper length and cut at Z, and the long link welded in permanently.

It should be remembered that the chain must always be set taut, and only then is the boat ready for *hooking on*. Either fall can be hooked independently.

The lanyard used for tripping the slip-hook should also be used as a preventer when the boat is hoisted, by hitching it forward around the chain, or thwart, or other convenient place.

To Lower and Detach when the Boat is reported ready. When the crew, coxswain and officer are in the boat, and after one of the stroke oarsmen has cast loose the lanyard, and handed it to the officer in charge, the officer of the deck gives the order to "lower away." As soon as the boat is near enough the



227

water, say about two feet, the person holding the end of the *laniard* gives a quick jerk, and thus freeing the ends of the chain, they slack and allow the *links* to rise and the *toggles* to escape simultaneously.

In case the ship is rolling heavily very little lowering will be necessary, as the boat can be detached as she rolls toward the water, and will be clear of the ship before the return roll.

To Hook on the Boat. As soon as the boat is clear of the ship one of the stroke oarsmen brings the ends of the chain together, refastens the *sliphook* and hitches the *laniard* forward as a securing.

The boat is then ready for hooking on when she returns to the ship, after having completed her trip.

When she comes alongside, the man in the bow gets the forward fall and sticks the *toggle* into the large part of the *link* and pushes it up beyond the *tumbler*. The man in the stern does the same, and as the falls are set taut on deck, they slue the turns out of the *falls*, the *toggles* acting as *swivels*.

BROWN'S BOAT DETACHING APPARATUS.

This contrivance for detaching boats is still in use on board some ships, and may be described as follows:

In Fig. 409, A is a fall block, C a bent lever with a slotted end, S, passing through a groove in the upright B, where it is hinged. The upright B is immovably connected at K with a stout stanchion bolted through the keel, and bears on its upper end a pivoting hook, H. The rod D hinges upon the lower end of C and upon the upright lever E, which is itself pivoted at O. By moving the handle G forward, the traction on the rod D causes the slot S to release the hook H, and this in turn releases the fall. As shown in the figure, the action on both falls is simultaneous.

The enlarged sketch, Fig. 409 a, shows the detail of the forward part of the apparatus. Fig. 409 b shows

the locking pin, by means of which the handle G is kept from being accidentally moved. In this figure, P is a plate screwed in the after thwart, D a space for the handle, B a locking pin, hinged at V. The plate is so placed that the locking pin is forward of the handle G, and must be thrown open before the handle can be moved.

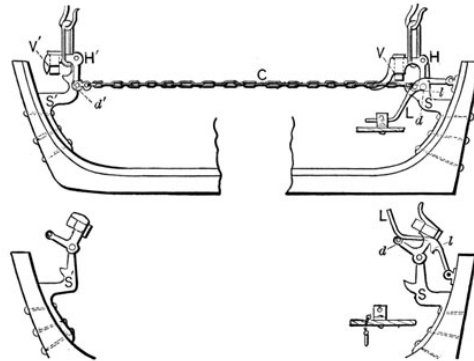
228

FISKE'S ATTACHING, DETACHING, LOWERING AND HOISTING APPARATUS.

The boat may be hung from the ordinary boats' falls, in which case only the attaching and detaching apparatus in the boat is used. It may also be hung from the lowering and hoisting apparatus herein described.

The lowering and hoisting apparatus consists of a pendant, into the bight of which the lowering and hoisting tackle is hooked, and at the ends of which the boat hangs. The tackle is hooked into a thimble seized in the bight, and the boat is suspended from long links seized in the ends. The tackle hangs up and down alongside the mizzen mast, the ends of the pendants being rove through two blocks under the mizzen-top, and down through single blocks at the upper ends of the quarter-davits. The boat is lowered and hoisted by lowering and hauling on the hoisting tackle. It is clear that the boat must hoist and lower square. It is clear also that the use of wire-rope pendants facilitates the operation of hooking on.

The attaching and detaching apparatus in the boat consists of two similar hooks, H and H', pivoted on two similar standards, S and S', which are bolted in the bow and stern



of the boat. The boat hangs by these hooks, which are kept from turning around on their pivots by the detaching lever L and the connecting chain C. A lug l on the lever presses against a lug d on the after hook H, and holds H in

229

place, while the connecting chain C, which goes from the lug d to a similar lug d' on H', keeps H' also in place.

To detach, take out the safety-pin placed over the lever, and raise the lever smartly. This movement raises the lug l clear of the lug d, and frees both hooks. Both hooks now turn around simultaneously with the weight of the boat, and the boat drops square.

To hook on, put both hooks, the lever and safety-pin in the position they held before detaching. Hook on by passing the links inside the hooks. This operation forces up the valves V and V', which fall of their own weight as soon as the links are inside, and automatically lock them in, to prevent accidental unhooking.

When the boat is lowered in port, unhook the connecting chain from the after detaching hook, and stow the chain forward out of the way.

[← Previous Part](#) [↑ Seamanship Home Page](#) [Next Part →](#)

CHAPTER XIV.

GROUND-TACKLE.

ANCHORS-CHAINS-THE CAPSTAN.

Anchors- Although the general form of the anchor has undergone but slight modification since the earliest ages, yet there are, even at this late day, as many opinions as authorities in regard to the best proportions and best shape of the various parts. There seems to be, however, a general concurrence in making the shank shorter and the several parts heavier than was common fifty years ago.

Anchors are of two kinds-*Solid*, or ordinary, and *Portable*.

The *Solid* or ordinary anchors are those which have the shank and arms wrought into one body, or mass, at the crown of the anchor, Fig. 414, Plate 86.

The *Portable* anchors are those which admit of being separated, and taken to pieces. Of this kind there are many varieties.

Figs. 414 and 415 show the wooden-stocked and iron-stocked anchor as commonly supplied to the service, the former being at present reserved for permanent moorings, iron-stocked anchors being furnished exclusively on board ship.

In Fig. 414:

The shank is all that part extending in a straight line from *a* to *b*.

The square is that part of the shank which extends from *c* to *d*, to which the *stock* is attached.

The arm is the part which extends from the *throat* (or *crutch*) to the extreme end, from *e* to *f*, including the *palm*, the *point* and the *blade*.

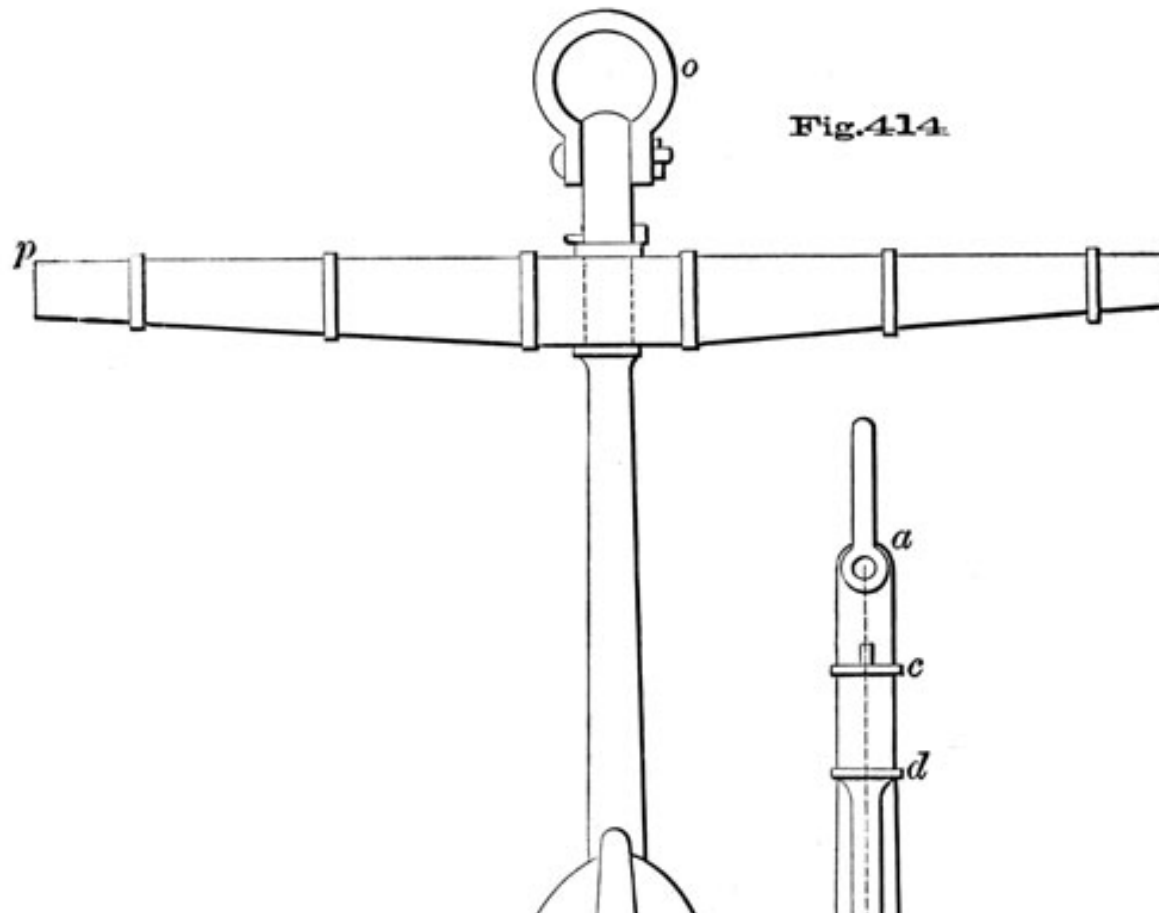
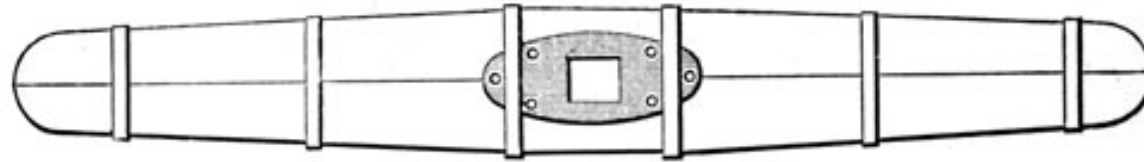
The palm or *fluke* is the part of the arm, of a shield-like form, from *g* to *h*, and constitutes the *holding* surface of the anchor.

The point (*pee* or *bill*) is the part of the arm included between the termination of the palm and the extreme end, from *f* to *h*.

The blade is the part of the arm at the back of the palm from *i* to *k*.

The crown is the external arch upon which the anchor

Plate 86



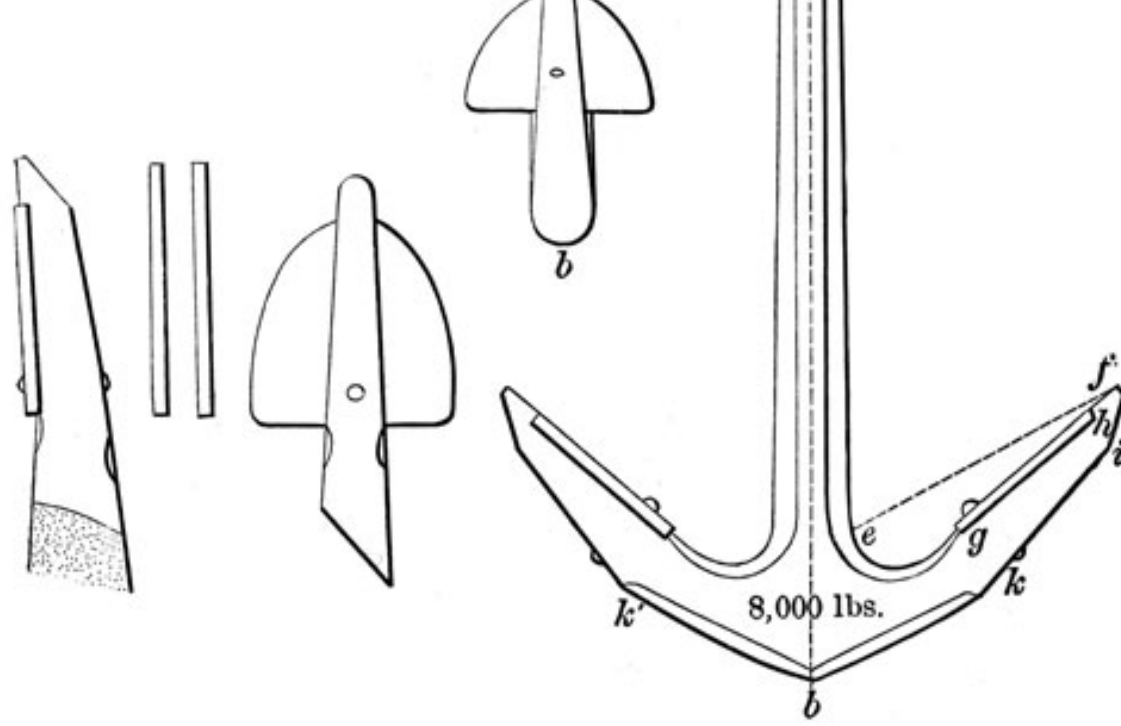
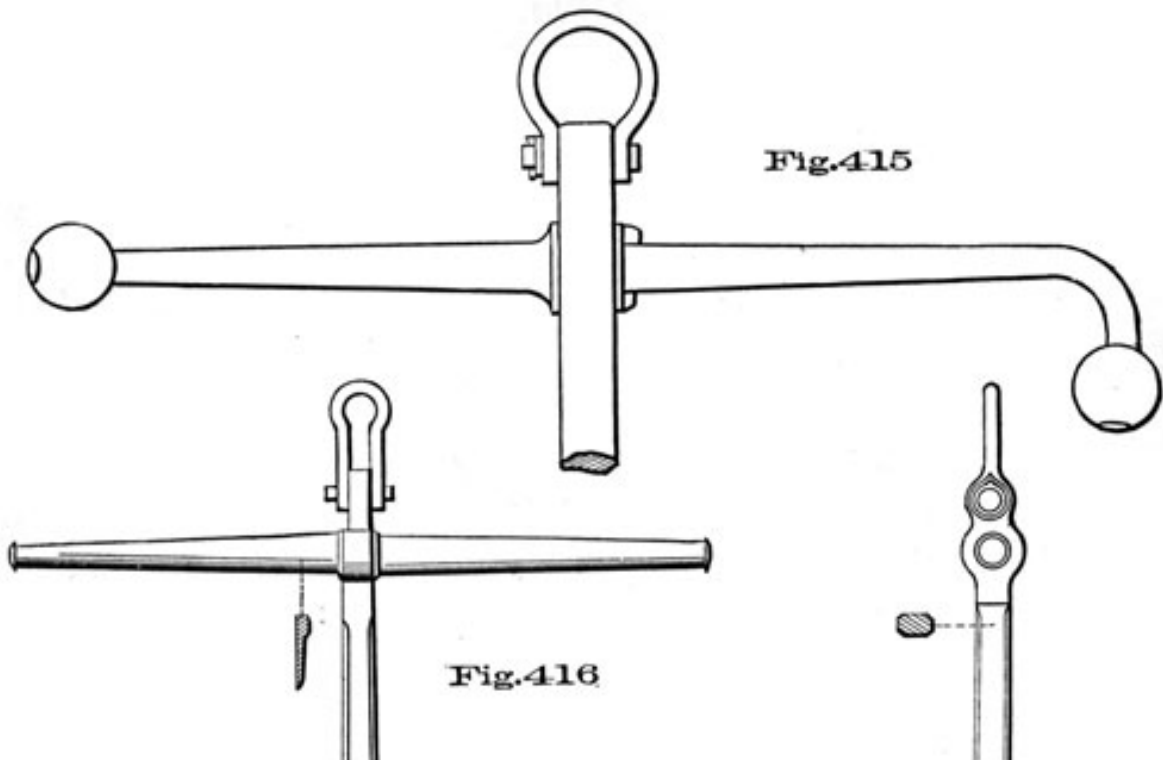


Plate 87



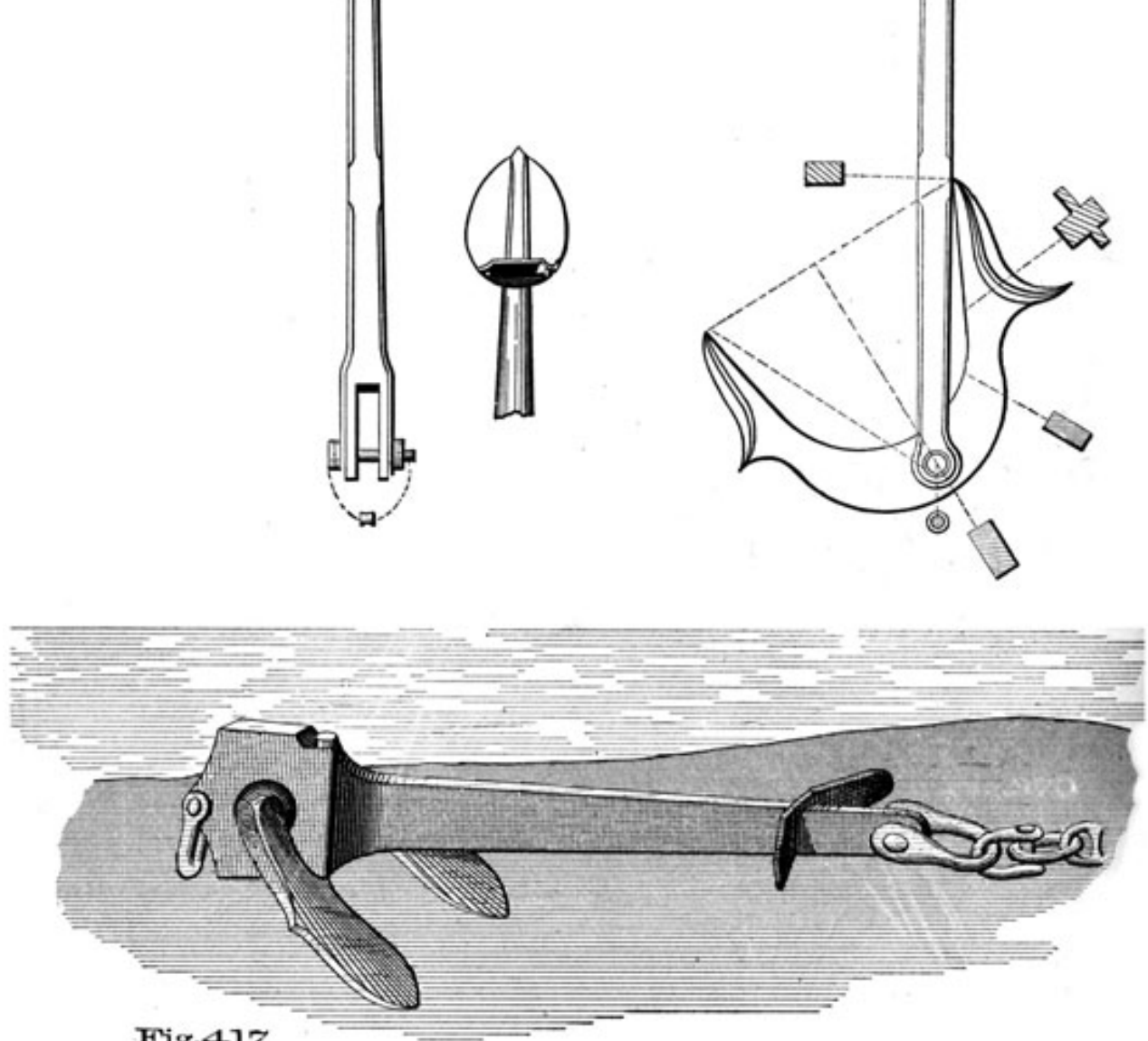


Fig. 417

falls when let go in a vertical position, and may be said to extend from k to k' .

The ring (or jews-harp), o, is the appendage by which the cable is attached to the anchor, by means of a shackle on the end of the cable, called the anchor-shackle. The last link of the chain, which is secured into this shackle by a pin, is of peculiar form, and is called the *club-link*.

The stock, p, is the transverse beam which cants the anchor when the arms fall in a horizontal instead of a vertical position.

The *throat* of the arms is the curved part at e , where the arms are joined to the shank.

All anchors and chains used in the navy are made at the foundry in the navy-yard at Washington.

Iron Stocks. An iron stock is generally a round bar of iron with a collar near the centre. It is put through a hole in the square of the shank, the collar resting against one side, and being kept there by a forelock which passes through the stock on the other side of the square. There is a washer between the forelock and the square.

A Wooden Stock has generally a square section tapering both ways towards the centre; it is encircled with iron hoops, and a square hole is cut in the centre to fit it on the square of the shank. An improved plan is to make it of two pieces, by cutting it lengthwise, and to forge projections from the square to be enclosed between the two parts of the stock and furnish large bearings; the two halves after being put on are hooped together.

Wooden stocks are made of oak, in two pieces left sufficiently apart in the middle to give greater binding power to the hoops, and to admit of their being driven up when the wood shrinks, a precaution which should be adopted after long exposure to a hot sun.

The following is taken from the Book of Allowances of 1881:

1. All anchors and kedges are to have iron stocks. The weight of an iron stock is, as nearly as possible, one-fourth of the anchor to which it belongs.
2. Bower and sheet anchors are to be alike in weight. The weight of an anchor or kedge, *as marked on it*, being inclusive of the bending-shackle and stock.
3. Stream-anchors, in all cases, when allowed, are to be about one-fourth the weight of the bower,

4. Kedges, when four are allowed, are to be, respectively, about one-seventh, one-eighth, one-tenth, and one-fourteenth the weight of the bower; when three are allowed, one-sixth, one-eighth, and one-tenth; when two are allowed, one-sixth and one-tenth; and when one is allowed, one-eighth.

5. To determine the weight of a bower or sheet anchor for a vessel, multiply her displacement in tons by the number

assigned to her approximate displacement in the following table, in the column headed, "Multipliers," and the product will express the number of pounds, *inclusive of stock*. This rule will give the intended weights, but, as anchors are not to the pound, they will be furnished as nearly in accordance with it as practicable, giving preference, especially in vessels from the sixth to ninth classes inclusive, to anchors having greater weights than the rule calls for.

6. Each boat of every vessel is allowed one anchor; the weight in pounds to be obtained by multiplying the square of the extreme breadth by 1.2.

ANCHORS AND KEDGES.

Size of Vessel	Multipliers	Bower	Sheet	Stream	Kedges
Over 3,700 tons displacement	1 3/4	2	2	1	4
Over 2,400 tons displacement	2	2	2	1	3
Over 1,900 tons displacement	2 1/4	2	2	1	3
Over 1,500 tons displacement	2 1/2	2	2	1	3
Over 900 tons displacement	2 3/4	2	1	1	3
900 tons and under displacement	3	2	1	1	2
First-class monitors	1 1/4	2	1	-	2
Second-class monitors	1 1/2	2	-	-	2

Patent or other anchors shall be of relative holding power, and will be supplied by special order.

Proof of Anchors. Anchors are tested by the hydraulic press, the proof strains being as follows:

Anchor. Cwt	Strain. Tons	Anchor. Cwt	Strain. Tons.
100	67	40	35
90	63	30	28
80	58	20	20
70	53	10	12
60	48	5	7
50	42	1	3

Portable Anchors. The two arms of a portable anchor, called flukes, are in most of them attached to the shank by means of a pin through the centre of the flukes, and through jaws forged on the end of the shank. The flukes may either be kept firm by forging lugs on them to embrace a shoulder on the shank, or they may move around the pin. In this case the extent of the motion may be

limited by a second pin through the shoulder, playing in a long hole in the flukes, or simply by the bills coming in contact with the shank. When the flukes are movable they have to be so shaped that when the upper arm is drawn as near the shank as possible, the other fulfils the proper conditions for holding. To force the arms to assume this position, it is necessary to provide each of them with a horn projecting outward just above the palm. This forms a secondary bill, which holds quick, and brings the arm in a position to hold also. The two arms may be forged separately, with a tenon at the end of each, by means of which they are fastened to the shank, on which mortises are cut to receive the tenons. Porter's anchor, as improved by Trotman, and known now by the latter name, is of this description; see Fig. 416.

Martin's Anchors, Fig. 417. A form of patent anchor supplied to some of the monitors, and specially adapted for vessels which require a clear deck forward for right ahead fire. Stock and flukes are in the same horizontal plane when the anchor is laid flat, both flukes taking the ground when the anchor is let go.

The Mushroom Anchor, is made without a stock, by substituting for the arm a cap, or reversed cup, called parachute, making the anchor represent a mushroom. Fig. 420, Plate 88.

One great advantage possessed by this anchor is, that it does not foul the chain, and for this reason it is used almost exclusively for our lightships.

A MUSHROOM consists of a heavy iron cup (the mushroom anchor without the shank), having on its convex surface a shackle. These are used for the anchoring of buoys.

Qualities of an Anchor. The following is a table of the relative values of the properties considered essential in a good anchor:

Properties	Values.
Strength	30
Holding	20
Quick holding	10
Canting	10
Facility of stowing	10
Exemption from fouling	5
Facility of sweeping	5
Fishing	5
Facility of transport in boats, quick tripping	5
	100

Anchors are brought off to the ship in lighters. Having them under the bows, overhaul down the cat and fish, hook on, cat and fish the anchor, passing the ring-stopper and

shank-painter, and bend the buoy-rope if used. It is recommended to bend a stout hawser to the ring of the anchor, in case of accident. It is also recommended to hook and pull up on the cat and fish together, for fear of injury to the lighter.

The method of getting the waist anchor into its berth has been given.

Jury Anchors. Having lost the heavy anchors, a stream or kedge anchor and a gun may be combined, the one giving weight and the other holding power, so as to answer very well for a temporary anchor; a spare anchor-stock, fish, or any suitable spar being lashed across to serve as a stock, Fig. 418, Plate 88. At the trunnions would be the best place for securing the stock, but it has been placed clear, in the figure, to show the manner of securing the kedge and strap to which the chain shackles. A heavy anchor with a broken shank may be treated in the same way.* This plan was suggested by Admiral Porter.

Guns are a resource, when without anchors. Haul a cable from the hawse-hole along the side, by a warp from aft, keeping it up with slip-ropes from the ports, and lash it to a certain number of guns round their chase; pass the end of the breechings round the cable, and secure them on the top of the gun; heave all overboard together. In weighing them, hoist them with the cat, as they reach the hawse-hole, and take them in through the bow-port.

Mitchell's Screw Anchor, Fig. 419. These are very powerful screws made use of for mooring purposes, which, having a broad flange nearly four feet in diameter, present a resistance, when entered into the ground, equal to that of ten square feet. This is not only much greater than that of an anchor, but is less liable to be fouled by other ground tackle.

The chain is connected with a revolving collar. The screwing down is effected by a key, which is placed piece by piece as the screw is lowered; the collar admitting of the turning, without fouling the cable. When the screw has been sunk to the desired depth, the key is removed.

The foundation for the lighthouse on Mapling Sands was formed on pilings shod with these screws.

A Sea Anchor. This anchor may frequently be of the greatest possible use, and may be made in the following manner: Take three spare spars (topgallant studding-sail booms will be sufficiently large), with these form a triangle; cut these spars to the required length, after cross-lashing them well at each angle; then make fast your spans, one to each angle, so that they will bear an equal strain when in the water; but should your spars be weak, you should always increase the number of spans accordingly;

* Jury anchors should be lowered to the bottom by slip-ropes.

Fig. 418

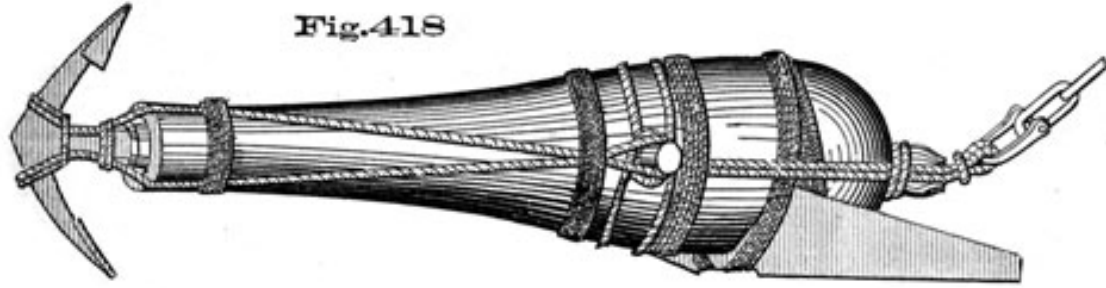


Fig. 421

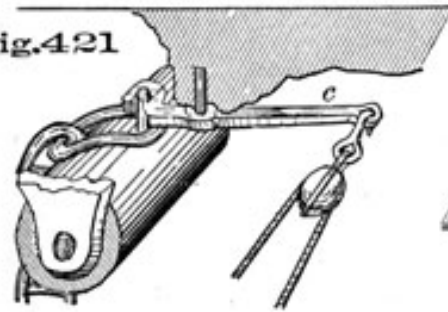


Fig. 419

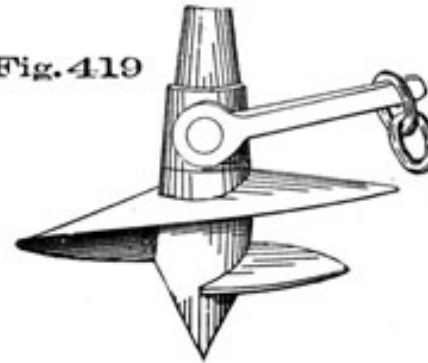


Fig. 422



Fig. 420

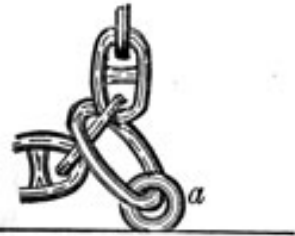
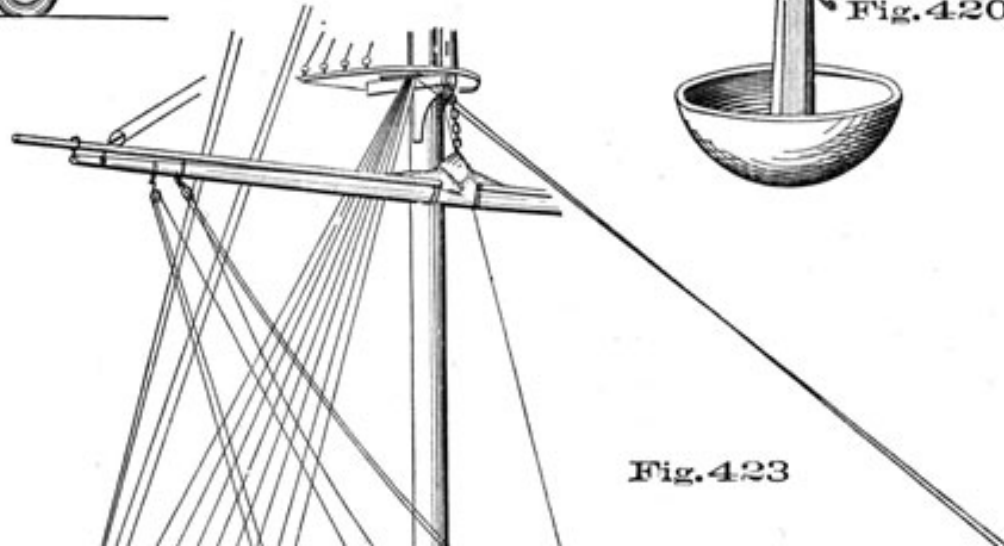
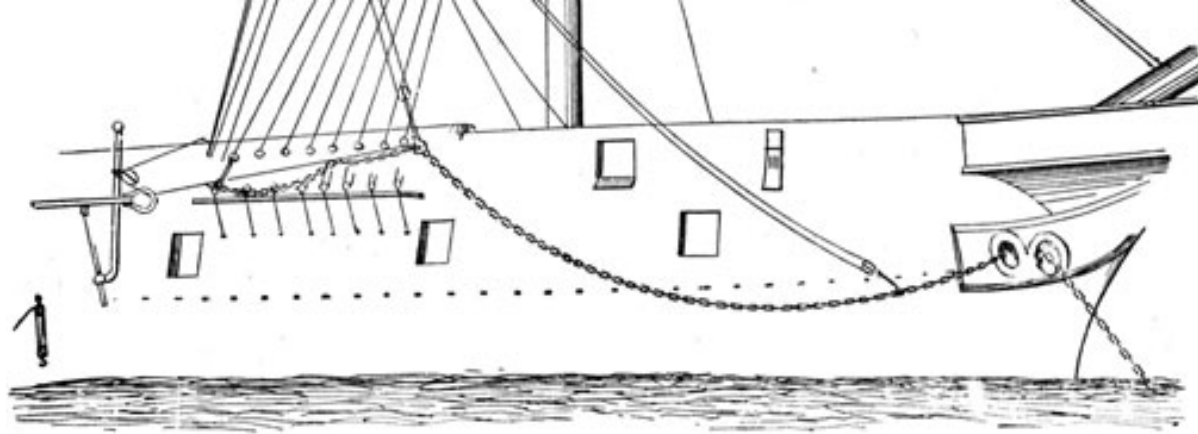


Fig. 423





fill up the centre of the triangle with strong canvas, having eyelet-holes round its sides, about three inches apart, through which eyelet-holes attach the canvas securely to the spars; at the back of the canvas pass many turns of inch or inch and a half rope, net fashion. A net would be preferable to rope so expended. To the base of the triangle attach a weight, or small anchor, supported in the centre of the base by a span running from each of the lower angles. To the first-mentioned span make fast the stream cable. When everything is quite ready, hoist or put it overboard from the place you think it will answer best. There is every reason to believe that with this anchor under the trough of the sea, and seventy or eighty fathoms of stream cable out, a ship's drift would not be very great.

If a ship should approach the shore with this sea anchor down, it would enable her to bring to with her proper anchors much easier than if the sea anchor had not been down. She might let go her proper anchor and veer from the sea anchor, until she had sufficient cable out, which would give her a much better chance of holding.

Another plan is to have two flat bars of iron, each in length half the breadth of the vessel's midship beam, riveted together in the middle by an iron saucer-headed bolt, clinched at its point, that they may be swung parallel to each other, for easy stowage. At each end of the bars is a hole for a rope or swifter to pass through, which must be hove tight to extend the bars at right angles. To this swifter is marled a double or fourfold No. 1 canvas cloth, of the same shape, and put on the side of the frame nearest the ship when used. At equal distances in the bars are holes to which is attached the bridle or crow's-foot for bending the cable or hawser. Also have a ring at one of the angles for a buoy-rope, which should be from ten to twelve fathoms long. The buoy prevents the anchor from sinking to the bottom, and facilitates getting it on board again.

Another sea anchor is that suggested by Captain P. Thompson, Examiner in Navigation for the Board of Trade, England.

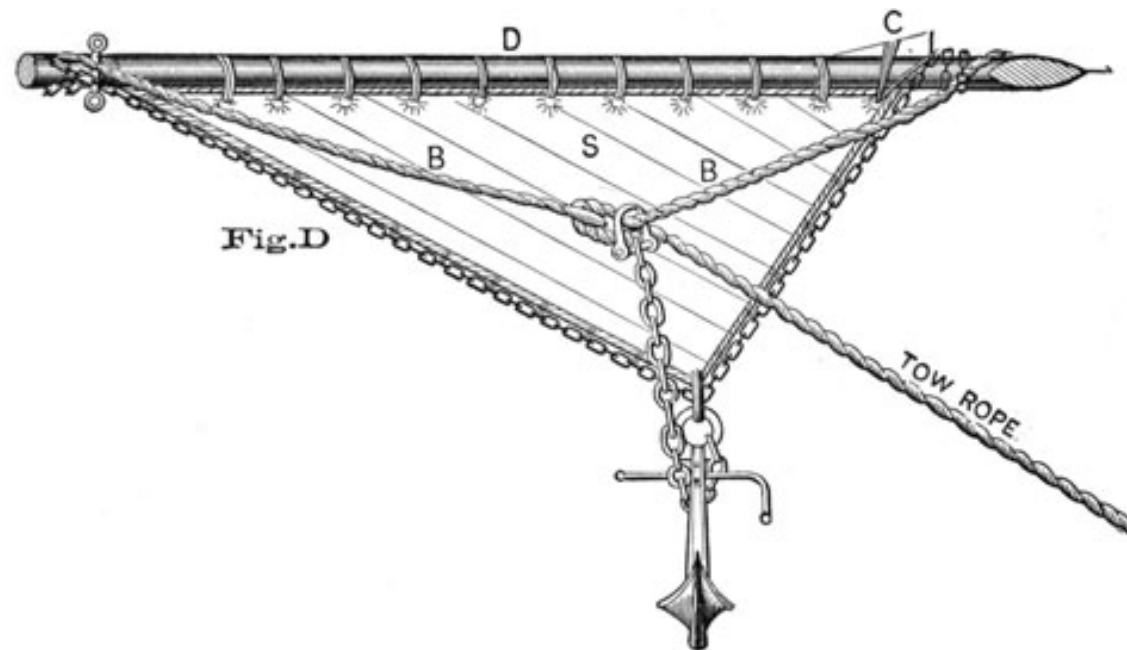
The cargo derrick of a merchant ship (or any suitable spar of a vessel of war) and chain, together with the storm stay-sail, offer the ready materials for constructing a sea anchor in a steamer, as is shown in Fig. D.

D, the cargo derrick; S, the sail bent to it; B, the bridle; and C, the cleat to keep that end of the bridle touching it in its place. The other end is kept fixed by the iron band on that end of the spar.

Through the shackle of a large kedge-anchor the bight of the derrick chain is hitched, and the two ends taken up alongside of the after-leech and foot-rope and seized to them

236

at intervals of two feet, the ends of the chain are then secured to the opposite ends of the spar.



On the other side the drag is snaked from chain to chain with two-inch rope.

A chain is passed from the anchor stock to that part of the bridle where the tow-rope is secured, the whole thing is then complete.

Blockading vessels on an open and exposed coast have used sea anchors with great advantage during bad weather.

CABLES.

Cables for the navy are made at the Washington Navy-Yard. An iron rod of the requisite length and diameter is shaped into a link and a stud put in, another piece of iron of the same dimensions is put through the link just formed, and shaped as before; thus fifteen fathoms are made, when a shackle is formed for connecting it to a second length, and so on for one hundred and twenty fathoms, or the required length, when we have the anchor-shackle and club-link.

The stud is said to add one-fourth to the strength of the link. The end links have no studs, in order to facilitate the operation of shackling, but the wire of these links is made the same diameter as the cable next in size.

It is customary now to connect the cable with the shackle and club link by means of an ordinary shackle and one *triplet** of chain. Fig. 441, Plate 95. This is done to avoid handling the heavier shackle at the anchor, leaving the latter attached in bending and unbending.

* A TRIPLET. Usually, three links cut from a chain, for testing.

237

When a length of chain is finished it is put into a hydraulic testing machine and proved.

RULE TO DETERMINE THE SIZE OF CHAIN-CABLE CORRESPONDING TO AN ANCHOR OF A GIVEN WEIGHT (INCLUSIVE OF STOCK).

Cut off the two right-hand figures of the number of pounds of the anchor's weight, and multiply the square root of the remaining quantity by 4; the result will be the diameter of the chain in sixteenths of inches.

Thus:

Weight of anchor in pounds	5,000
Cut off two right-hand ciphers, leaves	50
Square root of 50	7.071

$7.071 \times 4 = 28.284$ and $28/16 = 1 \frac{12}{16}$, the diameter of chain needed.

The size of a chain messenger, if used, is *two-thirds* that of the chain cable to which it is to be applied.

Swivels, Marks, &c. All chain cables are made with swivels at $7 \frac{1}{2}$, $37 \frac{1}{2}$, $82 \frac{1}{2}$, and $127 \frac{1}{2}$ fathoms, with shackles at every 15 fathoms from the anchor. Were it not for the swivels and studs the chain would get full of kinks.

Shackles are marked with *raised numbers*, from 1 to 9 inclusive, on the pin end opposite the head.

Old cables will be found marked with turns of wire around the stud of a link next to the shackle.

Shackles are put on so that the *rounded* part will be forward.

LENGTH OF CHAIN-CABLES ALLOWED.

Weight of bower-anchor, in pounds, including stock.	Length of chains in fathoms.		
	Bower.	Sheet.	Stream.
Over 7,500	135	135	105
Over 5,000	120	120	105
Over 3,000	120	120	90
Over 2,000	120	120	90
Over 1,600	105	105	75
Over 1,200	90	90	75
Over 800	90	90	60
Under 800	60	60	60

Shackle-Pins are made of iron, white-leaded before putting in. If they become rusted through neglect it is almost impossible to unshackle. Hence, at least once in each quarter, the chains should be overhauled, the pins backed out, carefully white-leaded and replaced.

Wooden pins are the best, but they shrink and fall out or decay, unless regularly overhauled.

Steel-*tinned* pins would be found serviceable. The length of the steel pin should be such that the extremities do not come through the shackle by the diameter of the point, and they should be fitted with dovetail chambers, to receive leaden pellets in the ends.

Getting Chains on Board. When lying in the stream the chains are brought off in scows or lighters, where they are ranged regularly in alternate layers fore-and-aft and athwartships, and the *bitter* end being passed through one of the vacant hawse-holes they are got on board and into the lockers by means of deck-tackles and chain-hooks. When working with the crew, men are stationed to stow the chains and are called *tierers*. The cable is paid down a few links at a time, while the tierers with chain-hooks and a hook-rope rove through a tail-block at some convenient place above them, in the after part of the locker, range the chain in regular fleets, using the hook-rope to form the after bights.

Prior to the stowage of the chains, however, it becomes necessary to secure the end below, as a preventive from loss, in the event of being unable to check its outward passage in veering; and perhaps the best method for accomplishing this object is the following; Through a ringbolt in the keelson, Fig. 421, Plate 88, the end of the chain is rove up to an iron roller, attached to a beam of the lower deck, immediately above the last link of the chain being curved, in order to fit over a short perpendicular arm on the surface of the roller, which is kept from turning by a check-lever, *c*, having a small tackle attached. In the event, then, of having to *slip*, it only becomes necessary to haul on the jigger, which permits a revolution of the roller, and disengages the link from the arm.

Or the bitter end may secure to a bolt overhead, as in Fig. 422.

Another very good plan is to have the end secured with a slip-stopper, Fig. 428 *b*, Plate 90, the tongue of which may be lashed down. But however the end may be secured, *it should not be at the bottom of the locker*, but out clear where it can be got at when required. This will enable a second cable to be shackled to the bitter end of the riding cable without rousing the entire length out of the locker.

Should the ship be alongside the wharf, *chain-shutes*, leading from the wharf through a port abreast the chain pipes are used. The chute is a strongly-made wooden trough, sufficiently wide and long for the purpose.

To Bend a Bower Cable. Reeve a ring-rope through a sheave in the cat-head, through the hawse hole, and bend it to the chain with a rolling-hitch a short distance from the end, to which it must be stopped.
Rouse

Fig. 424

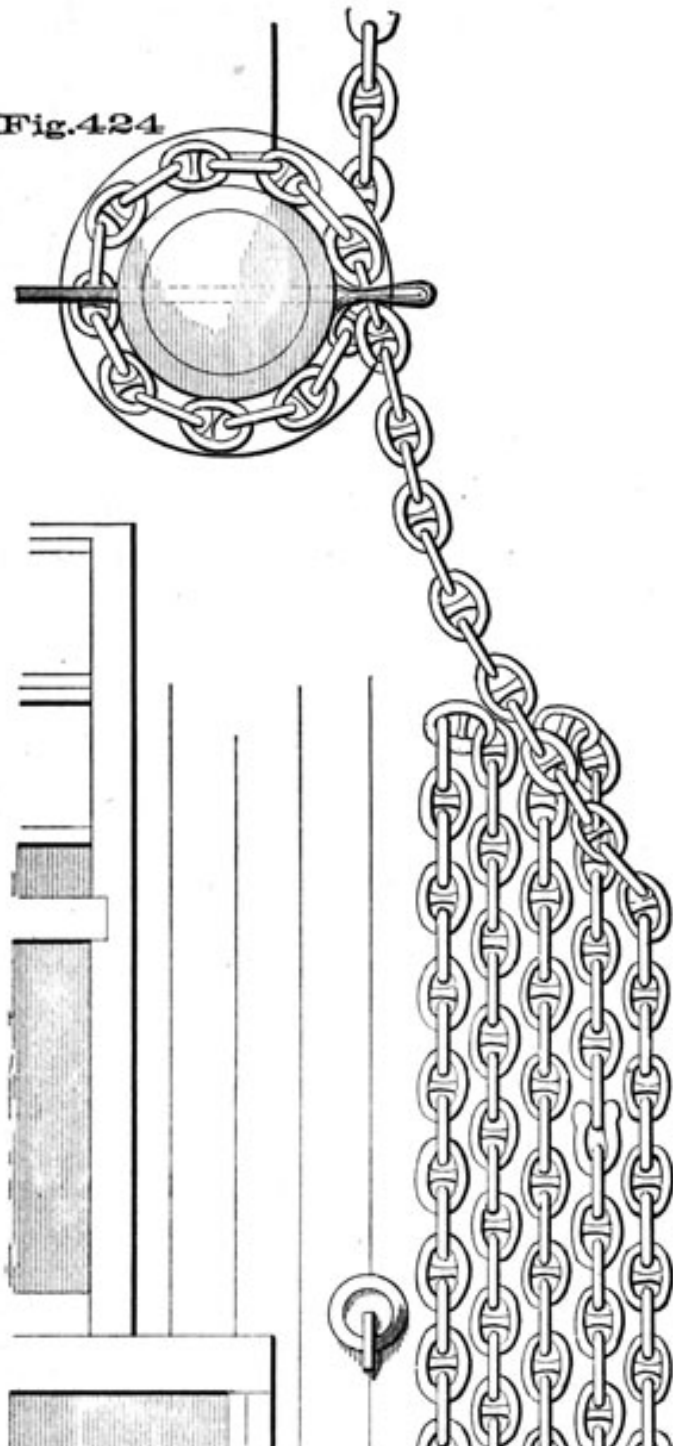
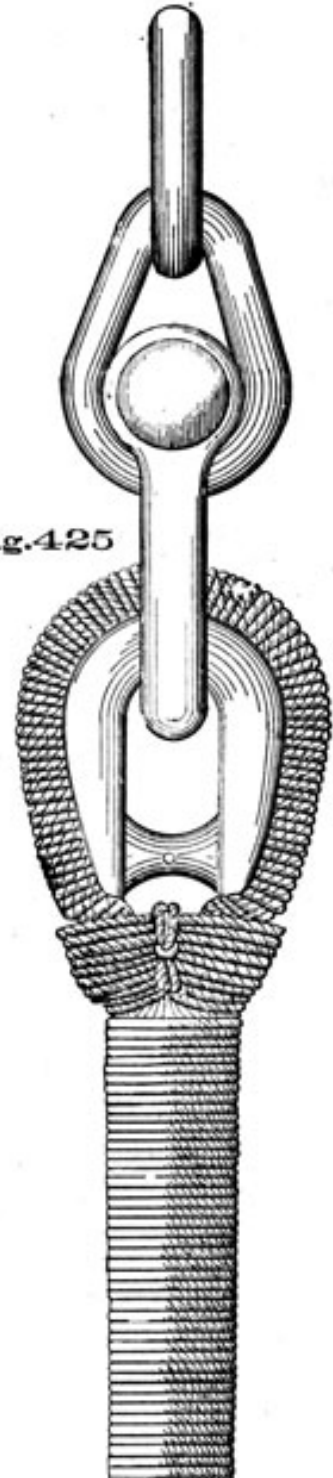
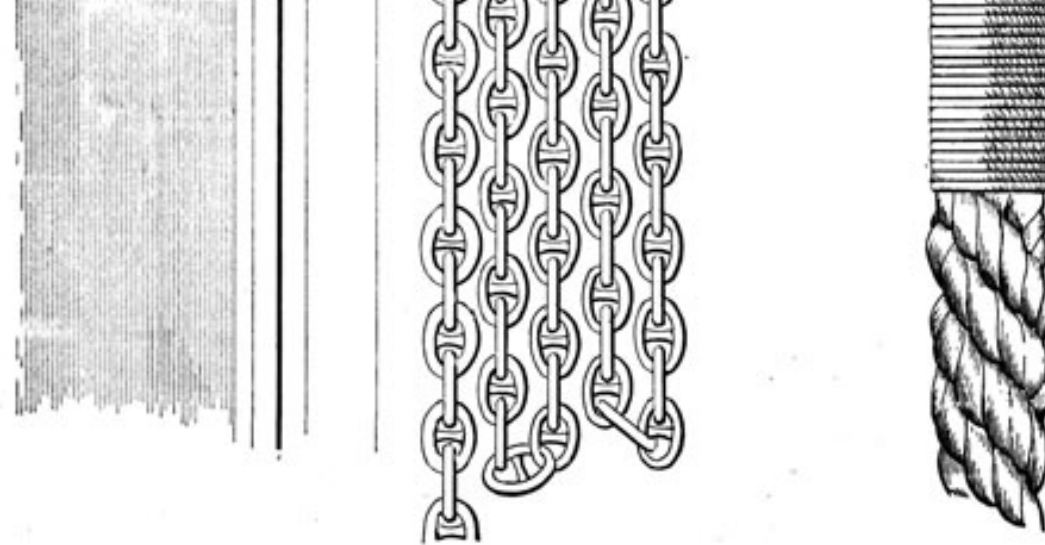


Fig. 425





the chain out (using the fore-bowline as a hawse-rope if convenient), and up to the cat-head, where the armorer shackles it where it belongs. If the cat-head is far from the bows, a slip-rope will be required to hang the cable half-way.

To Bend a Sheet-Cable, Fig. 423, Plate 88, the anchor being stowed in the waist. Stock the anchor and lash a snatch-block to the upper arm. Reeve off a ring-rope through the snatch block, taking one end in through the sheet hawse-hole, and bend it to the chain, leaving end enough for shackling.

Place two water-whips on the fore-yard, on the same side as the chain. After the chain is roused out a certain distance by the ring-rope, clap one whip on the chain, and when the first whip tends about up and down, clap on the second whip. If necessary, fleet the first whip forward again on the chain as more is paid out. The two whips support the chain while it is being hauled aft.

Slip-ropes having been previously pointed over the side, their outboard ends are picked up and passed inboard after the chain has been shackled, to light up the chain fair for seizing to the side-bolts. If the slip ropes are passed for a full due before the chain has been roused aft and relied upon to sustain the chain, they will make the work much heavier.

When the chain is shackled, clap on a back tackle, in wake of the back-lashing bolt, which is a short distance below the ring of the anchor and in line with the side-bolts, though heavier. Rouse the bight into place, pass the back-lashing* and tauten the chain along the side by clapping on a deck-tackle inboard.

Pass the seizings to the side-bolts, lighting up the chain with the slip-ropes, then unreeve the slip-ropes, unhook the yard-whips and finally the back-tackle.

The sheet-chain should always be bent after the second bower has been let go, if not previously done. Having bent it and secured it to the side, as described, it is not unusual to stopper it inboard, unshackle, leaving the end forward, and paying the balance of the chain below into the locker, until required.

The length of chain left bent to the anchor is called a *ganger*.

A Ganger. is any comparatively short length of chain, such as the one above described, or the length of *cat-chain* used in catting the anchors of ram-bowed vessels, as mentioned further on.

To Bitt a Chain Cable,** Fig. 424, Plate 89.

* In preparing to let go a waist anchor do not forget to cut the back-lashing. Also called an *elbow* lashing.

** The expression of bitting a starboard (or port) cable, whether *with* or *against* the sun, has always been a favorite subject for discussion in the steerage. But regarding the forward part of the chain as fixed, the slack is hove over the bitt-head, say the port side, *against* the sun, as will be seen by coiling down a rope in that way. On the starboard side, bitt *with* the sun.

Immediately over the bitt-head is placed an eye-bolt, to which is hooked a single block, having a hook-rope rove through it. Sufficient slack chain having being roused up, hook on to a bight and pull it up abaft and over the bitthead; form a cuckold's neck in it, so that the part leading from aft shall rest on top of the cavil and outside the bitthead, the running part being inside and leading down under the cavil and so forward; shove the bight thus formed over the bitt-head, slack down the hook rope and it will fall in its place. Now rouse the chain taut along the deck and pay the slack down into the locker.

To Weather-Bitt a Cable is to take an additional turn with it around the cavil or bitt-head.

To Unbitt, as when getting under-way, screw down the "Mix" stopper, or put on any adequate stopper forward of the bitts, take off the deck-stoppers, bend on a hook-rope, rouse up enough slack from aft, and unbitt.

To Range a Chain Cable, Fig. 424. Bend on a hook-rope or a chain whip, according to the size of the

chain, rouse up the requisite quantity, and range by placing it in parallel lines called *fleets*, fore and aft the deck between the bitts and the chain pipes, observing to let the part leading from the bitts, the running part, be outside of all, that from the chain pipe being inside; for were it reversed, the chain running out would find the last fleet forming a curve from the bitts, out towards the ship's side, and in again to the chain pipes, and as the strain came on it, it would sweep with immense force amidships, injuring anything that might be in its way, at any rate giving a violent surge.

Chains are rarely ranged, at present, for any considerable length. If too much chain is ranged it is likely to pay down over and foul the anchor.

When the anchor is let go suddenly, while headway is still on, to avoid danger, for example, or when anchoring in a strong tide, or fresh breeze, the chain will soon acquire very great velocity, and if permitted to run too much at a time it will be found almost impossible to check; therefore but few fathoms should be veered at a time, checking it with the compressor before getting too much headway.

HAWSERS.

Not counting stream cables, the largest hawsers found on board our ships are 10 inches in circumference, and from that they decrease in size to 5-inch tow-lines.

241

For convenience in bending to each other, in towing, &c., the *Elliott-eye* can be advantageously applied to the ends of large cables, having two or three links or a shackle attached.

The Elliott-Eye, Fig. 425, Plate 89, is made as follows: Put a whipping on the bending end of the cable a couple of fathoms from the end, and unlay it; splice two strands together with a long splice, making the eye thereby formed equal in length to the diameter of the thimble and the breadth of the seizing. Then, with the remaining strand, make an eye splice to come fair with the bight of the two strands; get the cable on a stretch and fid out the eyes thus formed; put a piece of rope between the two to fill up the hollow and hitch them over. On removing the fid, thrust in an oval-cut thimble large enough to receive the pin of a chain shackle, having it well tarred. Seize the thimble in with a round seizing of one inch and a half. Tail stuff on to the ends of the eye-splice, and worm it four or five fathoms down the cable, clapping on stops every four feet or so, to the end of the worming.

If the thimble is galvanized it need not be tarred. In no case should the thimble be parcelled, as the parcelling holds water and rots the eye.

WIRE CABLES.

Wire cables are being introduced into many English and German vessels, and the British Lloyd's have sanctioned the use of one flexible steel wire cable for steam vessels.

The principal advantage claimed for the use of wire cable over chain cable is uniformity of strength. Chain cables frequently have defective welds, but a wire cable is composed of many threads, and these completely break joint" with each other, and thus neutralize any defect in the wires.

There is also a great saving in weight. A chain cable with two inches thickness in each link weighs about 235 lbs. per fathom; while steel wire capable of superior strength weighs only about 40 lbs. per fathom, thus saving nearly 200 lbs. per fathom used, or many tons in a full length of cable. It is true that the weight of the chain cable greatly assists the anchor in holding the vessel, but the comparatively light wire cable may be attached to a suitable anchor of increased dimensions, and the greater facility of handling the wire must be of importance, especially as regards the time necessary to weigh anchor.

There is no noise in working the wire cable, and it may be stowed upon a reel on deck, thus avoiding the stowage in chain-lockers, forward, of a weight of chain which tends to strain the vessel at that unsupported part.

16

Wire cable has been in use on H. B. M. ships Valorous and Eclipse, and also on board some of the Channel steamers for some time.

The appliances for working it on board one of these vessels are as follows: The wire is fitted on the port side, and is 150 fathoms long, 5 inches in circumference, and weighs 28 1/2 cwt., with a breaking strain of 65 tons. An ordinary chain cable is fitted on the starboard side, and the lower part of the capstan is reserved for working this cable, while the upper part, and a sister capstan, placed just forward of it, works the wire, which is passed around them in grooves in the form of a figure 8; this avoids surging, as the rope leads on to the lowest ring on the main capstan, and to prevent chafe the grooves are set some distance apart. The wire cable stows on a reel conveniently placed abaft the capstans, on the same deck. Automatic nippers secure the cable by friction while the ship is anchored, one being placed where the port riding-bitt would stand, and the other in the eyes of the ship.

When the anchor is let go, the cable runs straight from the reel to the nippers and through the hawse-

holes.

Successful experiments have lately been made by the Bureau of Equipment in substituting mild steel for iron, in the manufacture of chain cables.

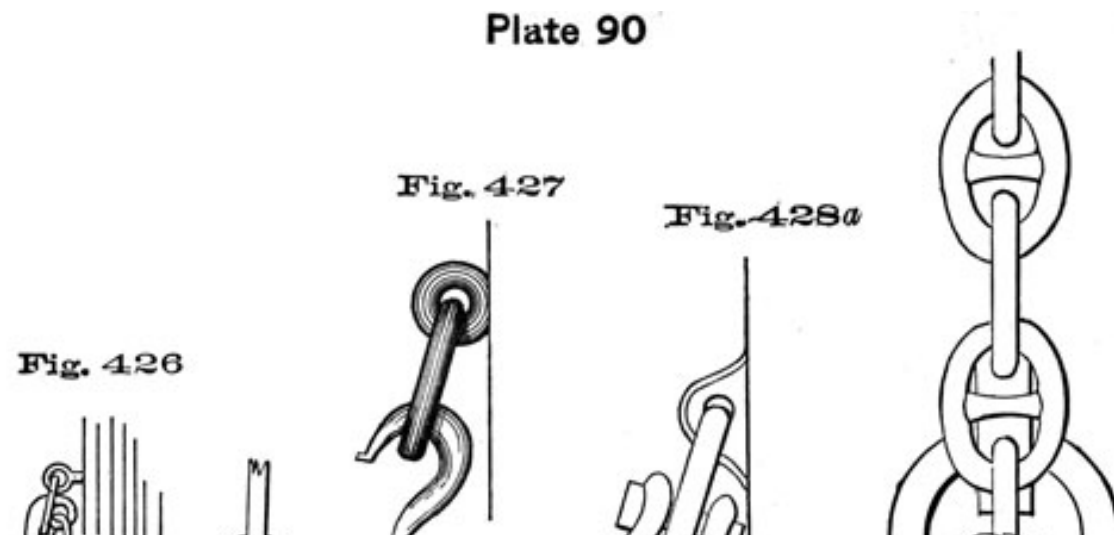
STOPPERS.

Deck Stoppers, Fig. 427, Plate 90, are made of plain-laid rope, are one fathom in length, when fitted, and are in size one-half that of the cable on which they are applied. In one end is spliced a hook and thimble, or thimble alone, which is hooked or shackled to the stopper ring-bolts in the deck; in the other end is formed a stopper knot, with a laniard one-third the size of the stopper, attached with a running eye around the stopper close to the knot. The laniard is passed from inboard outboard, the stopper lying inboard of the chain, leaving a fathom of the end to worm forward on the cable; the end is then secured by passing the tails around the links.

Deck stoppers are sometimes fitted of chain, with a devil's claw, large enough to receive one of the links of the cable, over which it is placed, and retained by a small iron pin, running through both parts of the claw. In the other extremity a slip-hook and ring are attached, by which it is secured to the stopper-bolts of the deck, Fig. 428. The length is about four feet and a half, and the size depends upon the class of vessel for which it is required.

For wire-rope deck stopper see Fig. 50, Plate 12.

Ring Stoppers are very useful and neat. The bights are passed over the cable abaft the ring-bolt, both



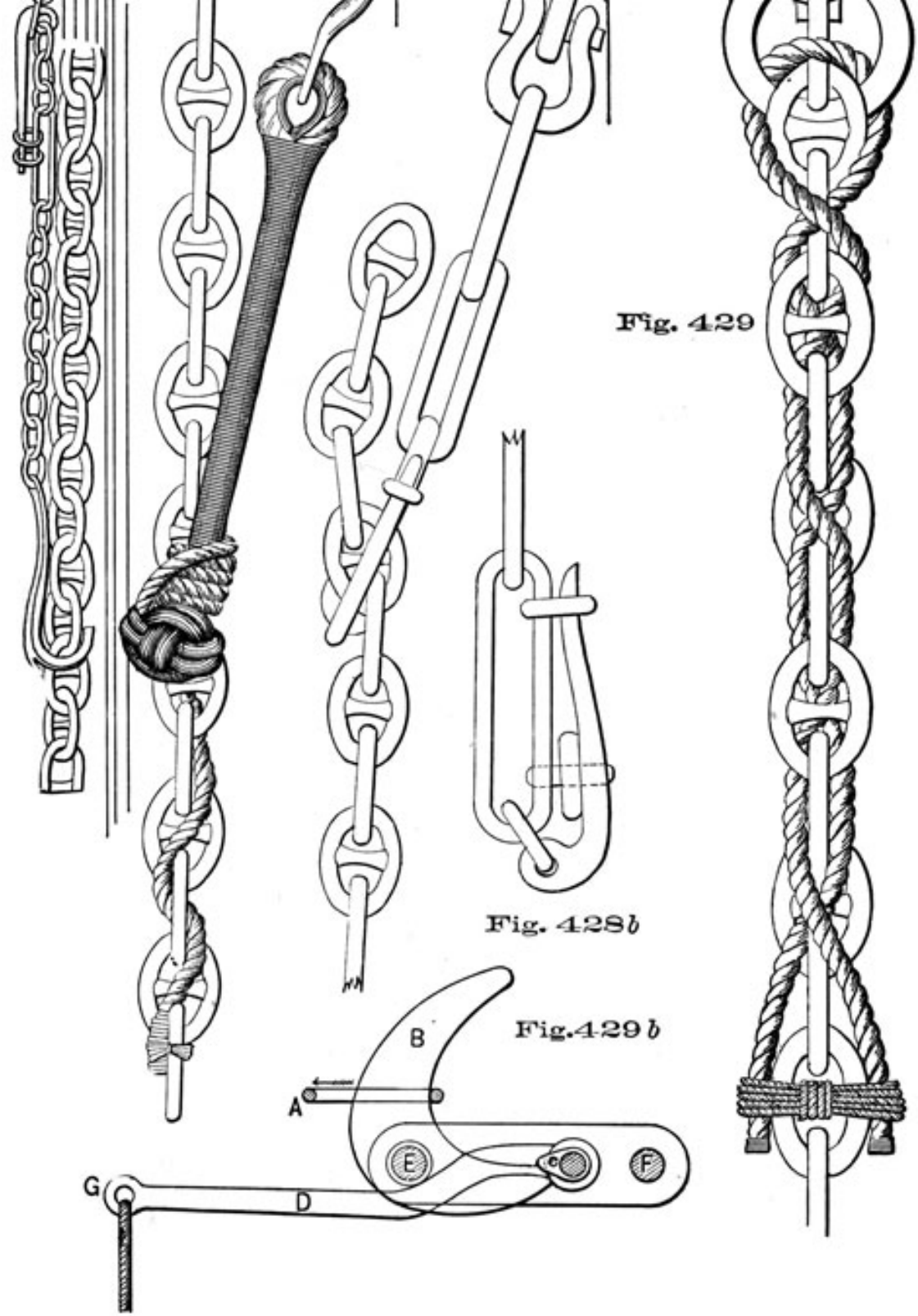


Fig. 429

Fig. 428b

Fig. 429b

ends are rove through the ring, and dogged around the cable forward of the bolts; the ends may be tapered, coach-whipped, and laid up in a square sennit. Fig., 429, Plate 90, shows a ring-stopper of plain-laid rope.

The ring-stopper above described for securing cables must not be confounded with the ring-stopper used to secure the ring of the anchor at the cathead.

Bitt Stopper. Fitted similar to the ring stopper, ends coach-whipped, &c., the bight going over the bitt instead of through a ring-bolt in the deck.

Check Stoppers are small strands of old rope which secure the cable to the ring-bolts in the deck, and, parting as the strain comes on them, *check* the cable in running out.

A Compressor having been carried away, to check a Cable while running out. This must be done by using ring-stoppers, Fig. 429. The two ends of the stopper are passed on different sides of the cable, forward through the ring-bolt, then dogged round the cable working forward, the two ends being knotted together when sufficient turns are passed; the bights are kept overhauled and triced up to the beams, the part abaft the ring-bolt by one stop and those before it by another; by letting go the foremost stop, the parts of the stopper catch the cable, and as they tauten break the after stop. "Check" stoppers alone would not be sufficient.

In the same way, you can veer through the laniard of a deck-stopper.

The Slip-Stopper, Fig. 428 (*a* and *b*), Plate 90. This is fitted with a crane-hook and shackle, and is found very convenient when working cables, as in clearing hawse, surging, &c.

Mix's Stopper consists of an iron casting like a hawse-pipe, set in a strong oak frame-work on the after-part of the manger. A thick and strong slab of iron, scored out on the under part to admit a vertical link of the chain, moves up and down in a groove, in the after-part of the frame-work, by means of a screw placed vertically over it. This stopper is exceedingly convenient, but the ship is never allowed to ride by it. The controller replaces it in modern ships.

Fighting Stoppers. Though not belonging to this portion of the work, we may mention here *fighting-stoppers*. These are kept at hand, ready for use at any time, particularly when going into action. They

consist of a pair of dead-eyes or bull's-eyes, rope-strapped, with tails, and a laniard rove, Fig. 431, Plate 92.

Each end of the laniard is fitted with a bight, so that a jigger may be hooked into either end, the other end becoming a standing part.

Stoppers with which to hold on, while hauling taut

244

a brace, sheet, or other rope, are fitted with a hook and thimble at one end, or they are otherwise secured to eye, or ring bolts near the rope for which they are required. In using them a half-hitch is formed around the rope, which after the rope is hauled taut through it, is jammed, and the tail wormed along in the lay of the rope; this will hold it while being belayed. Fig. 74, Plate 13.

Iron Compressors are used generally under the chain pipes. They check the chain with certainty, and are easy to handle.

Iron compressors are of various kinds, The oldest and best-known pattern is that of the curved iron arm, one end of which works on a pivot-bolt, so as to permit the curve to sweep the lower orifice of the chain-pipe. The other extremity has an eye formed in it, to which is hooked a small tackle. When veering, if the order is given to *haul to the compressor*, the tackle is hauled upon by the men stationed there, and the chain is compressed by the iron arm against the side of the chain-pipe.

Plate 91, Fig. 430, shows the elevation of the compressor, in which

a is the chain-pipe.

b, chock let down through the deck (*c*) to the beams *d d*.

g, bent lever pivoting on bolt *f*, which, by the use of a tackle, is made to nip the chain against the pipe and beam. The cable has been found to force down the compressor and the bolt (*f*), which has caused the introduction of the strap (*e*).

m, carlings let down between the beams to form a bed for the iron pipe (*a*).

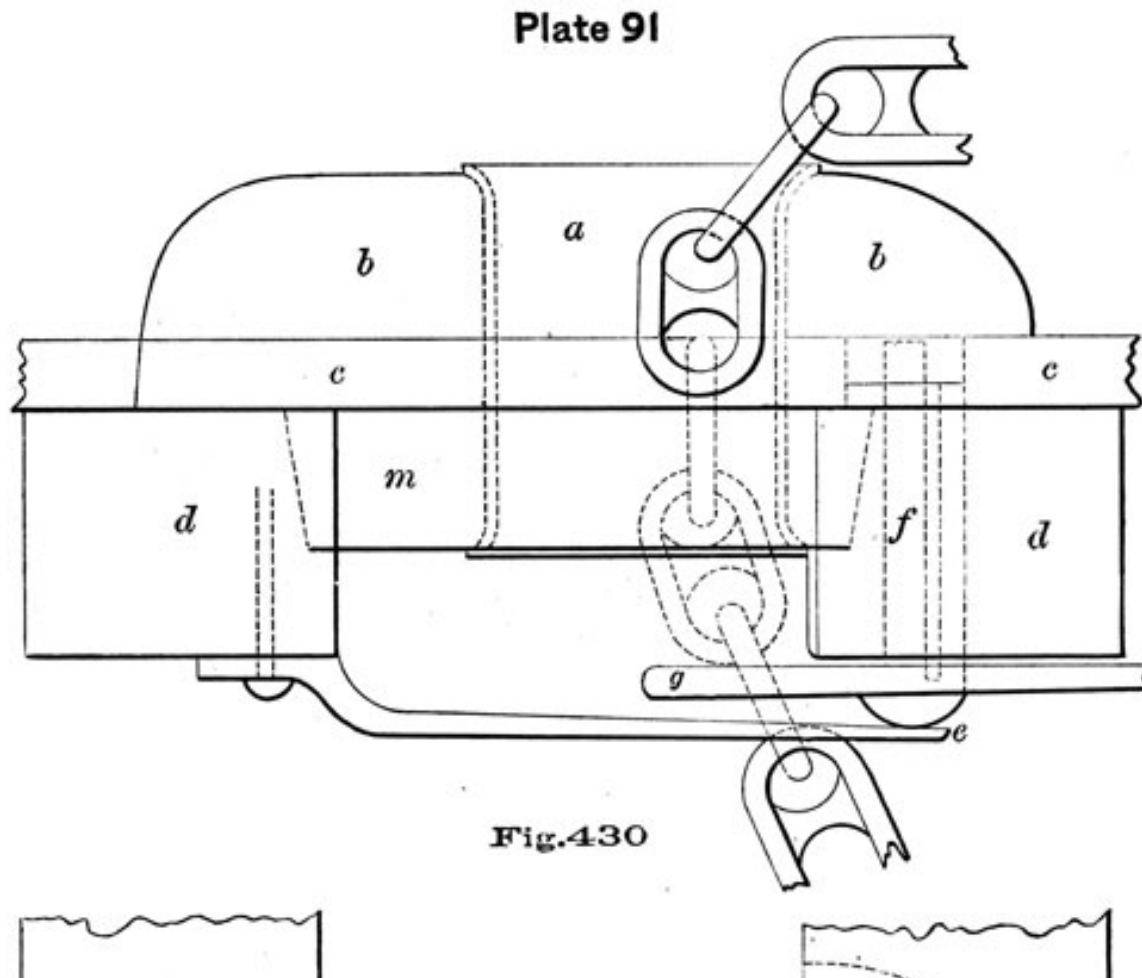
The plan represents (Fig. 430 *b*), the underside of the deck and beams; *k*, head of bolt (*f* of elevation), on

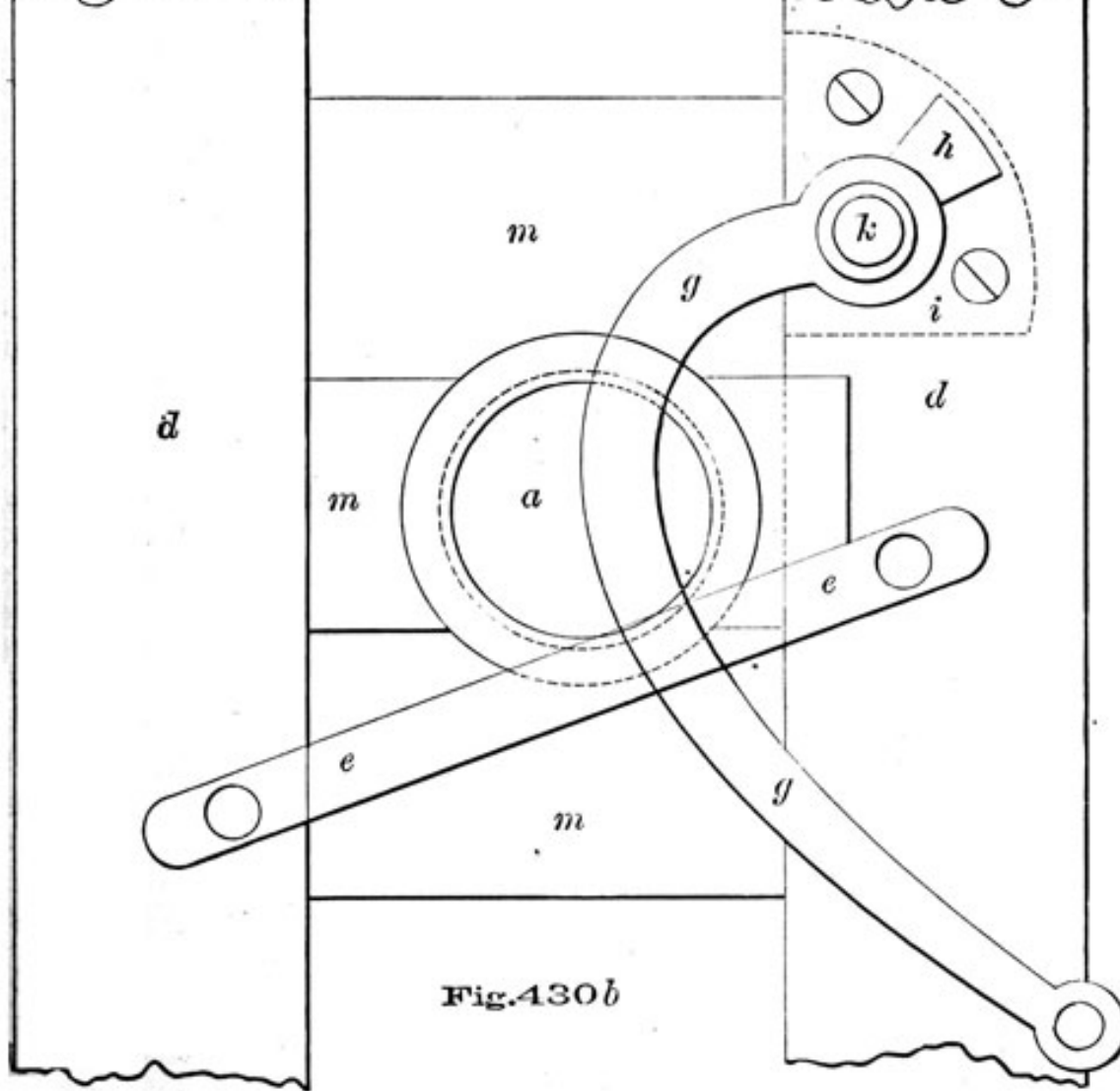
which the compressor revolves.

h, a fan or balancing arm worked in the compressor to assist the strap (*e*) in keeping the compressor in place.

i, an iron plate on the under side of the beam to form a hard surface for the fan to work upon.

A Controller (Fig. 437) is a cast-iron block, having a swallow in its upper side in the shape of a link of the chain cable. Controllers are bolted to the deck, forward of the bits, and also in large ships forward of the chain locker pipe. The cable, while lying in the controller, tends of itself to drop into the hollow *slot*, and while there is held by one of its links, which lies flat in the hollow, but at the bottom of the hollow is a jog or short lever arm, which can be raised by a longer lever, and so lift the cable out of the slot when it runs out, until the lever is let go and the jog dropped.





THE CAPSTAN.

The mechanical power employed in ships to heave in the cable, and thereby raise the anchor, is a modification of the wheel and axle; it is technically denominated a capstan, one portion of which, called *the barrel*, around which the rope is wound, answering to the axle of a mechanical machine; the other part, the head with the bars, being analogous to the wheel. To set this machine in motion, a moving power (the crew or steam) is applied to the wheel, and the rope being by this means wrapped around the barrel of the capstan, the weight or cable is raised. The cable itself comes to the capstan in all modern forms of that power. Formerly, however, cables were connected to the capstan by means of a rope or chain, styled a *messenger*, which did pass around the capstan and was made to unite itself firmly to the cable by means of *nippers*.

The messenger, which may still be seen in use on old-fashioned capstans, is commonly a rope or chain formed into a long loop, and, when of rope, long enough to allow of three or four turns around the barrel of the capstan, and then for each part to reach to a vertical roller in the manger, where the ends are united to form the loop required. This loop, moving around the roller and capstan, when the latter is set in motion, draws the cable inboard and aft when united to it by the nippers. When a chain messenger is used its links work over studs placed around the barrel of the capstan. A rope messenger goes around the barrel itself and increases the length required by three or four turns around the barrel, which have to be taken to prevent slipping.

A frigate is usually fitted with a double capstan, the upper barrel being on the spar deck, the lower on the main deck, on which the hawse-holes are also placed. Connecting "drop pauls," or pins, connect the upper with the lower capstan.

The holes in the head of the capstan are termed *pigeonholes*. They receive the capstan bars which work the capstan. To secure these bars, holes have been bored through the head of the capstan and through the bars and pins placed in them. At present the capstan bars are usually kept in place only by a rope wound around their outer ends, joining them together and called a *swiftering line*.

The *drum-head* is the circular top of the capstan, in which are the pigeon-holes.

Pauls are stops which are fitted so as to drop from the sides of the capstan against a *paul-rim* or *racket*, to prevent the recoil of the capstan.

The ribs or sides of the capstan are termed *whelps*.

Fig. 435, Plate 93, represents the American capstan, the chain being taken directly without the use of the messenger.

Fig. 436, Plate 93, shows Brown's patent capstan.

b, elevation of the lower capstan with fittings at the lower part of it formed of iron, *the ribs or wild cats*, *g* in it, acting like teeth or sprockets to clasp the cable, similar to the sprocket-wheel with studs, as shown, Fig. 435 *b*, Plate 93, of the common capstan.

e, elevation of a friction roller, round which the cable is wound, as shown on the plan, three or four being used as marked.

d, of the plan, shows the controller for stopping the cable. See also Fig. 437.

h, the cable leading to the hawse-hole. The method of bringing the cable to the capstan may be traced on the plan; the links shown in dotted lines being those in contact with the ribs (*gg*) of the elevation.

The Windlass used in small vessels is a capstan with the barrel worked horizontally, the power being applied by levers, which are shipped or worked in holes similar to those in the capstan-head.

In bringing a hawser to a capstan, take three or four round turns around the barrel, the *inboard* part being always the *upper* turn.

To get the Anchors off the bows. Bend the chains first, hook the *stock-tackle* to a strap around the upper arm of the stock and to a bolt on the opposite side of the fore-castle, and haul it taut.

Hook the bill-tackle to a strap around the inner arm of the anchor and to a bolt across the deck, setting it taut also.

The stock and bill-tackles are stout luffs.

Single the shank painter, and secure it at the mark where it is to be when the anchor is ready for letting go. Come up the shank, stock, and ring lashings, or ring rope, pry the anchor off the bill-board with the anchor bar, easing away the stock and bill-tackles as necessary.

The *ring-stopper*, which holds the ring of the anchor to the cathead, is not touched.

A fore-and-aft tackle on the pee of the anchor keeps it from scending forward while getting it off the bows.

To let go an Anchor. The anchor being off the bows, with chain bitted (bitt pin in) and clear for running, is held in place by the ring stopper and shank painter. Fig. 439, Plate 94.

The former, which is of chain, passes through the ring of the anchor, and the last link is placed over a hinged tumbler on the cathead, maintained in an upright position by means of a hook-lever extending across the cathead, Fig. 439*a*. The shank painter secures in a similar manner

Plate 92

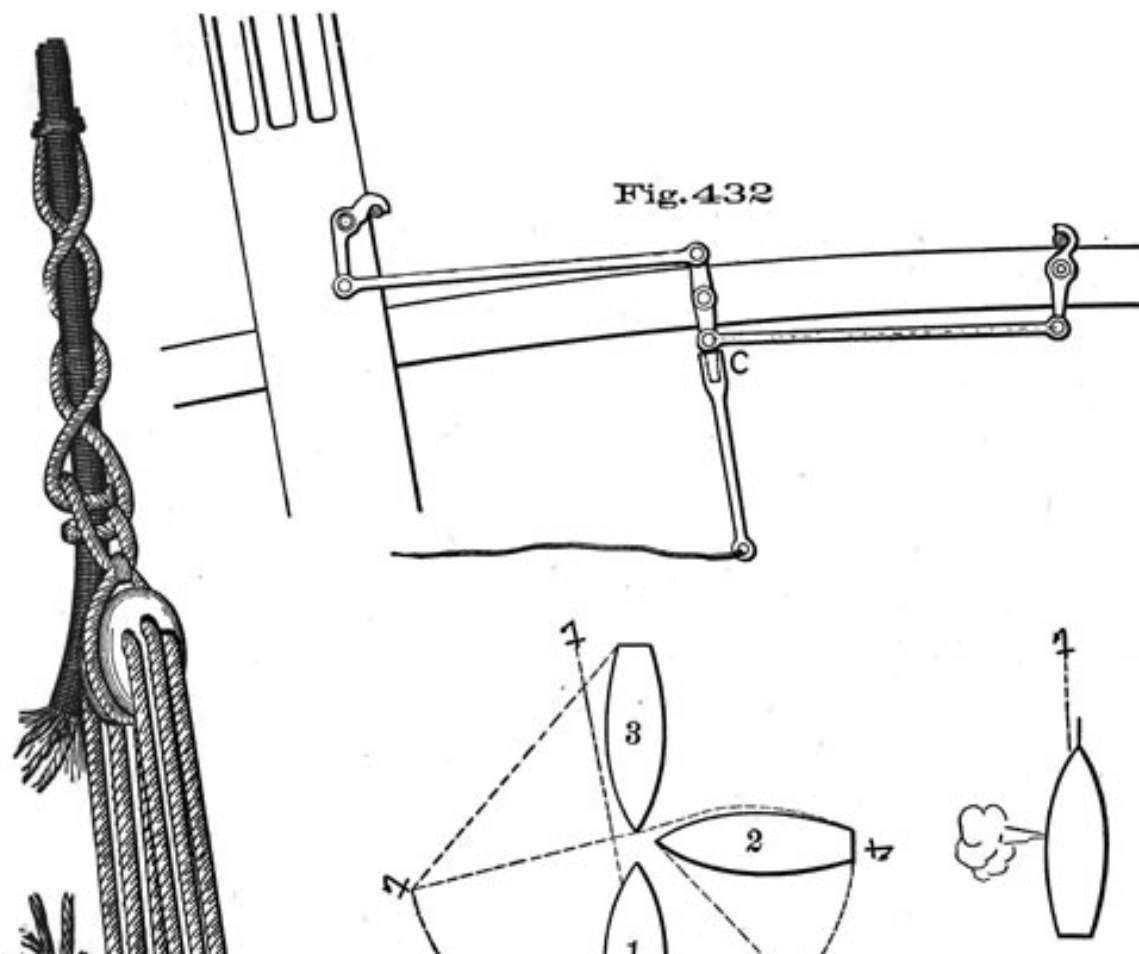




Fig. 431

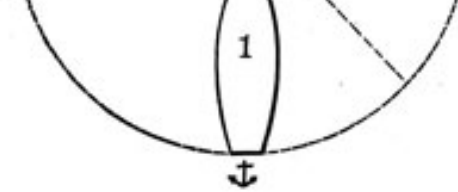


Fig. 433

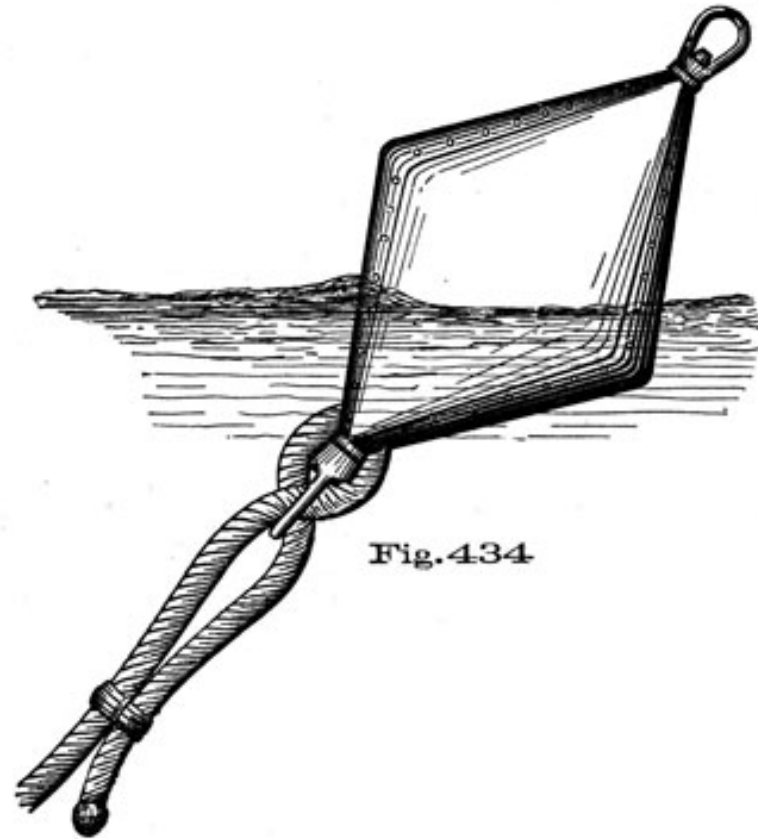


Fig. 434

Plate 93

Fig.435

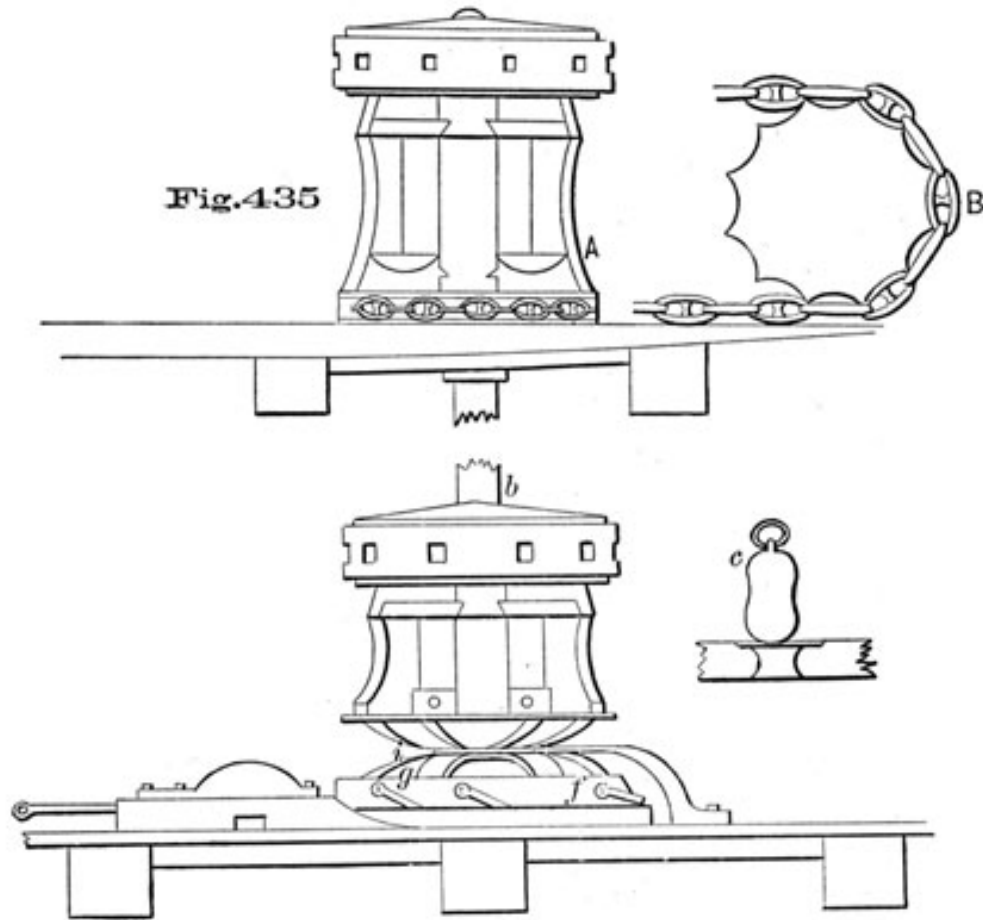


Fig.436

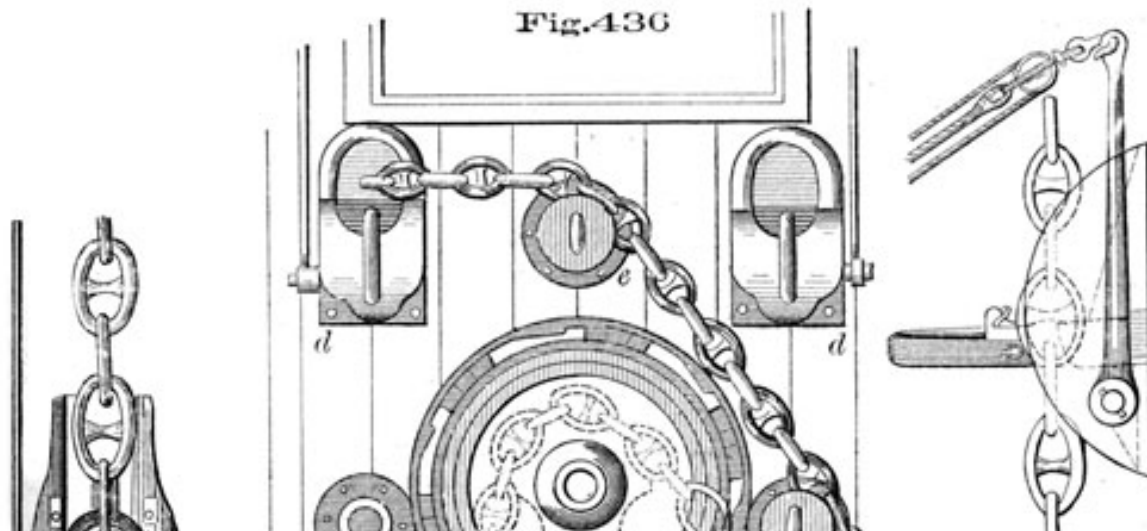




Fig. 437

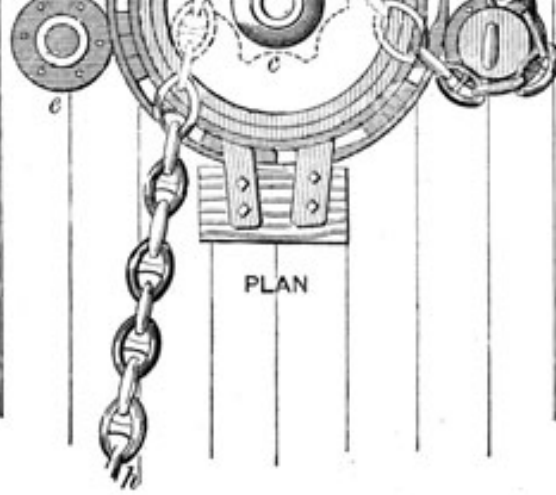


Fig. 437 b

Plate 94

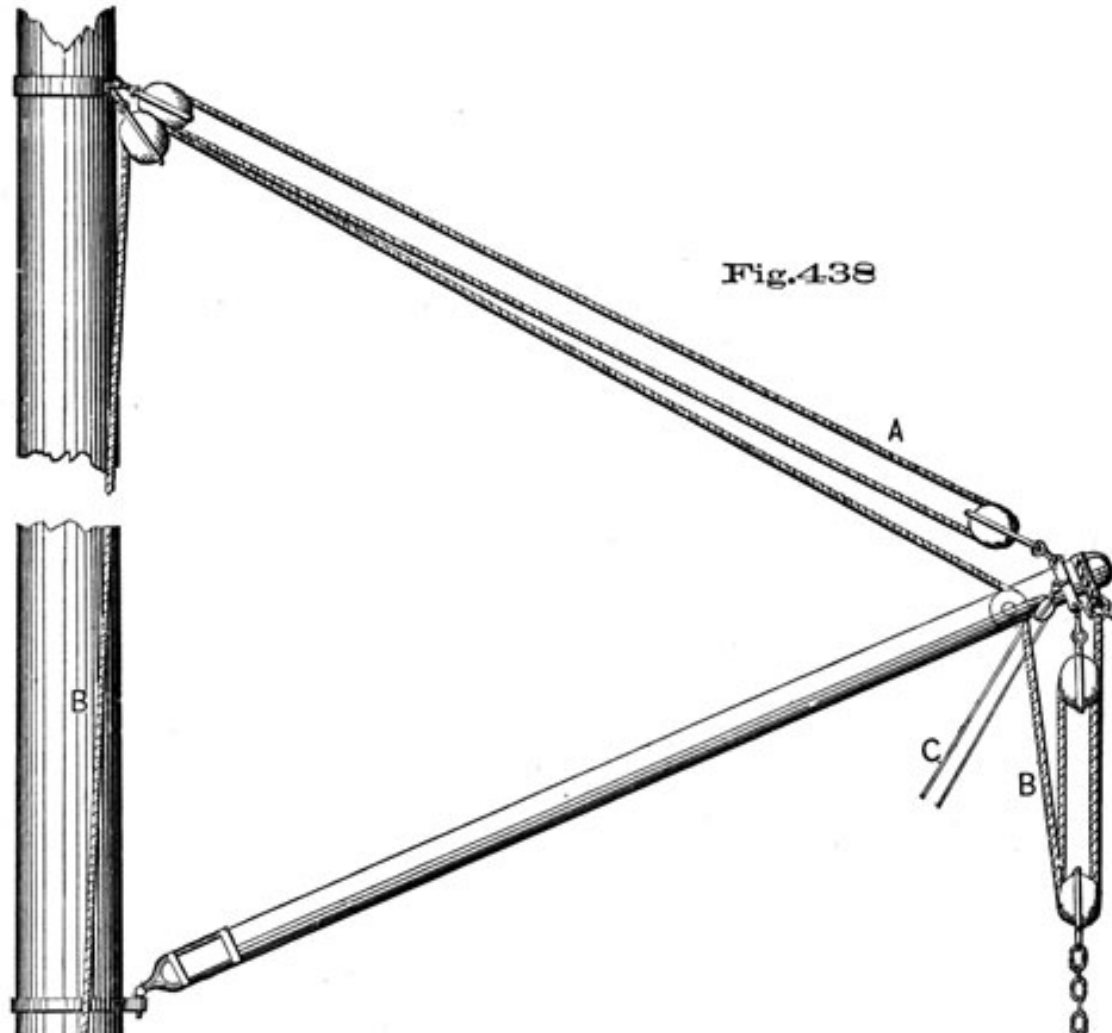
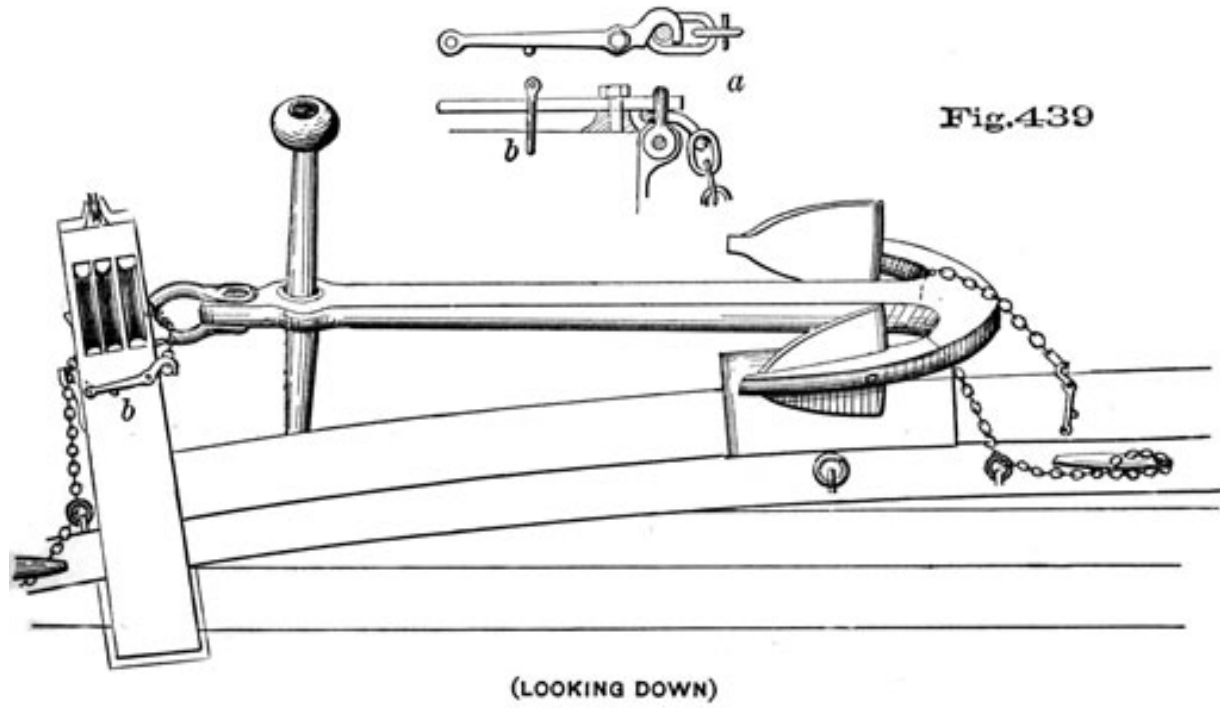


Fig. 438



at the bill port. To each of these a trigger may be attached, as in Fig. 432, Plate 92, fitted with a small bar leading to the arms of a swivel, worked by a lever shipped in the mortice *c*. Hauling on the lever disengages both stoppers at the same instant. Or the levers holding the hinged tumblers, Fig. 439*a*, are knocked out of position by men stationed for the purpose, at the order, "*Let go the starboard (or port) anchor!*"

In either case remove *first* the safety-pin, *b*, Fig. 439.

The order for letting go is always preceded by the caution, "*stand clear of the starboard (or port) chain!*" and sometimes by the order to "*stream the buoy!*"

See hands stationed at the compressor, which is hove back.

Before letting go anchors, it is frequently necessary to run in the guns directly underneath them on the gun deck.

To bring a chain to the Capstan. Rouse up enough slack from the locker to unbitt, having the chain well secured forward of the bitts.

When unbitted, haul the bight of the chain around the rollers placed so as to give the chain a fair lead from the hawse pipe to the capstan; thence about half way around the same in the score of the ribs, or wildcat, and back around similar rollers to the chain pipe.

To heave up an Anchor. The capstan being rigged, capstan bars shipped and swiftered in, the cable is stoppered before all, then unbitted and "*brought to*" the capstan.

Man the bars! Heave taut! Take off the stoppers and HEAVE AROUND! As the cable comes above the water, if muddy, it is cleaned with a hose led from the head pump. Sand the deck if necessary, in case the chain is very muddy, to prevent the men from slipping.

By the capstan are stationed the gunner's gang, with chain hooks, to light the slack chain around the rollers and toward the chain pipe; some hands are also provided with pinch bars to knock the links out from the ribs or wildcat of the capstan if they jam, as is sometimes the case.

The cable as it comes in is paid below, or ranged ready for running.

When a vessel has two anchors down, in heaving in on one cable, it becomes necessary to "veer to" on the other. To do this, if the veering cable is the weather one and in a stiff breeze, veer around the bitts, taking

off the forward stoppers and slacking the laniards of the after ones, or taking off all stoppers and tending the controller and compressors.

But if the veering cable be the lee one, it may be previously unbitted, and veered from the locker.

When all the slack cable is hove in and the chain leads

right up and down from the hawse-hole to the anchor, the officer of the forecastle reports, *Up and down, sir!* When not quite up and down, if circumstances seem to require it, he may report, *Short stay, sir!*

A cable is said to *tend* in a certain direction: thus the cable "tends broad off the starboard bow;" and when this occurs so as to make a short nip of the chain, and cause a heavy heave, it should be reported, as a change of the wheel, or in the disposition of the sail, or a turn back with the engine (as when on a windward tide the ship has overrun her chain), may bring it to tend right ahead and ease the strain on the capstan.

When the anchor is clear of the ground, report *Anchor is aweigh!* and when the stock is visible, *Anchor in sight! Clear (or foul) anchor!*

And when it is up high enough for catting-*The anchor is up, sir!* Or direct the boatswain to pipe, *Belay!* The order from the quarter-deck will then be, *Hook the cat!* Fig. 440, Plate 95.

The cat having been previously overhauled down, the block is hooked to the ring of the anchor by a hand on the stock aided by the cat-back. When hooked, set well taut on the cat-fall, and caution them on the gun-deck to be ready for surging the chain; then report, *All hooked with the cat!* As soon as this is made known, the order is given, *Haul taut!* WALK AWAY WITH THE CAT! The chain is surged, and the anchor walked up to the cat-head; at the proper time the boatswain pipes *belay*, when the order is given to *Hook the fish!* As soon as the cat is up the ring-stopper is passed. When the fish is reported, *Haul taut!* WALK AWAY WITH THE FISH! and when the fish is belayed, pass the shank painter.

Surging the Chain. When, as very frequently occurs on heaving in, the chain comes in muddy, it must be ranged on deck instead of paying it below in the lockers; thus fifteen, twenty, or more fathoms of chain may accumulate on the deck. Now when the order is (Oven to surge, the controller is hove up and the anchor swings to the cat. Should the cat part at this time, or other similar accident happen, the anchor goes down, carrying with it the entire range of chain; and if on board a steamer she may, by that time, be going

ahead under a full head of steam. Therefore, in place of relying entirely on any form of controller, clap a stopper on the chain, allowing a fathom or so of slack for catting. For this purpose an iron nipper securing the cable to a ring-bolt, or a slip-stopper, is very convenient. This precaution insures you against accident, and very little practice serves to enable one to stopper at the proper link to give slack chain enough to allow the anchor to go to the cat-head.

Cat-Falls. Begin with the *standing* part and reeve the end down through the forward sheave of the cat-head,

Plate 95

Fig. 441

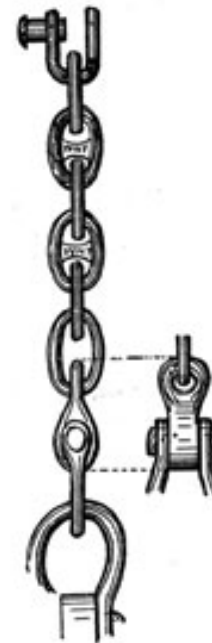
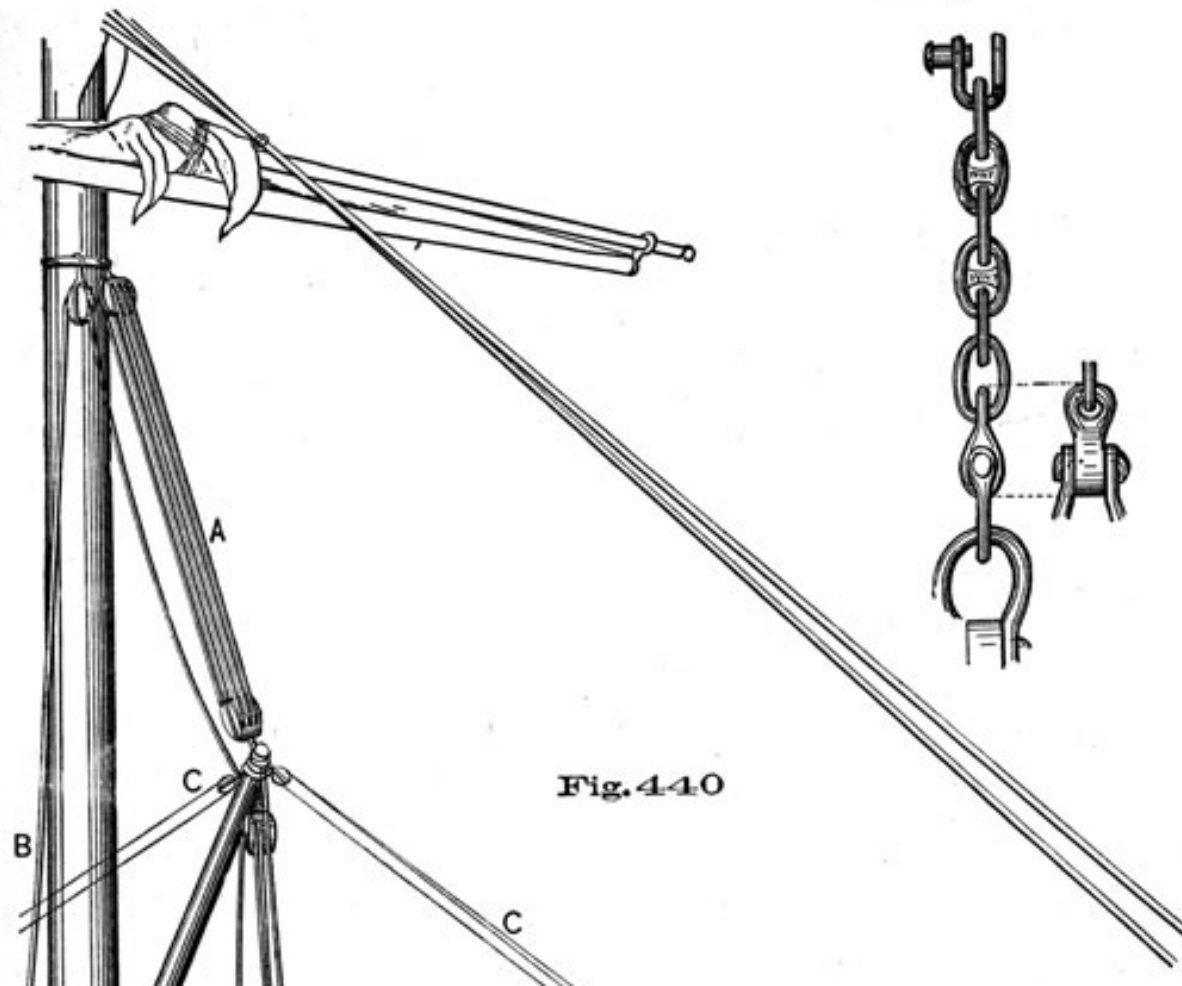
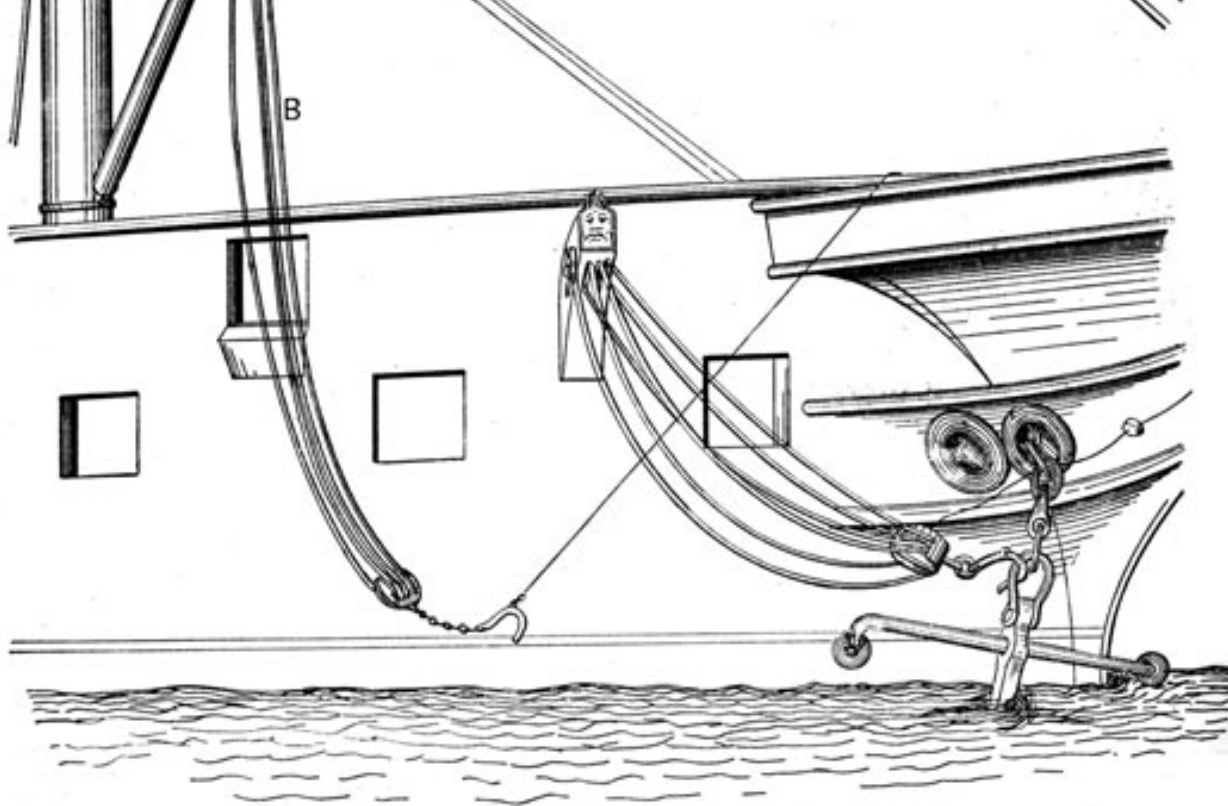


Fig. 440





through the forward sheave of the cat-block, placed so that the bill of the hook will point *inboard*, and so continue till rove full, when timber-hitch the end around the cat-head. In large ships it is found convenient to place the block in the bridle-port for reeving the fall, after which round it up and trice back the hook, if not wanted immediately.

Cat-Backs are temporary, and for the purpose of facilitating the hooking of the cat. A small rope is rove through a block tailed on to one of the fore-tack bumpkin stays, or an eye-bolt conveniently placed over the bows, and bent to a small eye-bolt or span on the forward cheek of the cat-block, the fall leading inboard. Another one may be bent to the back of the hook. With the assistance of these, the cat is hooked.

A Fish-Back is for the same purpose, and is bent to an eye on the back of the hook.

Anchor Trip-hook. Fig. 429*b* represents a section of the trip-hook in use on board the Fish Commission steamer Albatross, and is essentially the same as that generally used in the merchant marine. A, represents a link which is made fast to the middle of the shank of the anchor, the weight of which acts in the

direction of the arrow. From the figure, it will be seen that the weight presses the hook, B, against the cam, C, which, in turn, is held in place by the lever, D, the lever resting against the bolt, E.

The arrangement is attached to the lower block of the anchor tackle by the pin, F, which allows it to swing freely.

The tripping-line, G, is made fast on the forecastle, with sufficient slack to allow the anchor to be lowered to the desired point for letting go.

To detach the anchor, slack away the tackle until the tripping-line, G, acts on the lever, D, releasing the hook, B, and link, A.

The same style of trip-hook is also used in the place of the cat-hook, where an anchor is catted and fished in the ordinary way, so that the anchor may be let go from the cat without waiting to pass the ring-stopper.

Fish Davit. The present plan in the navy is to have a boom which attaches to the forward part of the foremast by a goose-neck. The boom is rigged as in Fig. 438, Plate 94.

A is the topping-lift, hooked to a band around the lower mast, near the futtock-band.

B, the fish tackle.

C C, guys.

See also Fig. 440, Plate 95.

The hauling part of the fish-fall may either lead through a sheave in the boom, or a block on the boom, thence to a block hooked to the mast-band, and on deck.

By this purchase (the fish) the flukes of the anchor are

raised until up to the bill-board, when the *shank-painter* is passed. This is made of chain; when passed, the chain encloses the shank; the end, rove through a ring in the side or waterways, is belayed to an iron cleat at the side. The shank-painter being secured, the purchase is unrigged, the fish-davit taken inboard, and the anchor now hangs by the ring-stopper and shank-painter, and is ready for letting go.

If the shank-painter is eased off so that the anchor hangs by the ring-stopper, it is then said to be *cock-billed*.

Iron fish-davits similar in form to boat-davits, and stepped near the bill-board, are taking the place of the wooden fish-boom.

Catting and Fishing a Sheet Anchor Stowed Forward. Modern vessels have frequently two cat-heads, one abaft the other on each bow, the after one for the sheet anchor. In tating the sheet, hook the forward cat; surge, heave the stock clear of the water, and hook on the after cat. If the fish-davit is not a movable one, the fishing will have to be done with a tackle from the fore-yard.

Catting Anchors on Board Armored Vessels. In ships built with ram-bows it is difficult to heave the anchor up high enough to hook the cat. That difficulty is met in the British service by the use of a *cat* and *ground* chain, of which the following is a description:

A length of small chain is shackled to the ring of the anchor and stopped along the first length of the cable; this is called the *ground chain*. A corresponding chain reeves through a block at the cat-head, styled the *cat chain*. Before weighing, the lower end of the cat chain is taken through the hawse-pipe, and when the end of the ground chain is hove in, the cat and ground chains are connected, the cat purchase (which hooks into the upper end of the cat chain) is manned and hauled taut; the bight of the small chain being eased out of the hawse-pipe, "WALK AWAY WITH THE CAT!"

British turret ships are supplied with Martin's anchors, which lie flat on the deck when stowed, stock and flukes being then in the same horizontal plane.

To afford a right ahead, fire from the turret and avoid unnecessary anchor gear, these anchors have *at their balancing point on the shank* a shackle to which the ground chain is attached.

A single iron davit with the cat chain rove and connected (when the anchor is hove up) to the ground chain places the anchor horizontally in its position on the bow.

The davit works on a hinge at its base, and stows flat on deck, a temporary derrick being rigged forward of the foremast to raise the davit when required.

To Secure a Bower for Sea. Having passed the ring-stopper and shank-painter, proceed to *ring up* the anchor by swinging the fish-boom to plumb the cat-head, hooking the fish between the stock and ring and pulling up on the fish tackle. Take through the slack of the ring-stopper, which is rove through a ring like the shank-painter, and secure it around its cleat for a full due. Hook the stock and bill tackles as in getting the anchor off the bow, haul on the stock tackle to bring the lower end of the stock clear of the side; then go to the bill-tackle and rouse the anchor up on the bill-board, and so to each tackle alternately till the stock is up and down and the inner arm lying on the bill-board, when the slack of the shank-painter is taken through and the lashings passed. It is better to haul alternately on the stock and bill tackles as described, as this prevents the palm of the anchor coming in with a surge, which would occur if the stock were hove up and down at the first pull.

Should there be no fish-boom to ring up the anchor, reeve a stout rope (*not* the cat-fall) through the sheaves of the cat-head and the ring of the anchor, secure one end to the cat-head, and clap a tackle on the other end.

If a long passage is contemplated, the chain is unbent and stowed below when the ship is off soundings, and the hawse-bucklers are closed and secured. Besides the ring-stopper, a good lashing is passed through the ring and over the cat-head, also one around the stock and through a ring in the side.

Foul Anchor. The question of clearing a foul anchor is one which requires good judgment, and one in which the circumstances may vary greatly. As good a general rule as any is to hook the cat (if necessary with a strap) to whichever end of the anchor is first sighted. It will often happen that there is but one foul turn of the chain, under the stock. In that case, if the cat is hooked in the ring, with a turn taken in the opposite direction to that of the chain around the stock, the strain on the cat after surging will throw the chain clear.

The anchor comes up *with the cable foul of the stock*, and ring uppermost, and in such a manner that it cannot be cleared as above stated. Cat as usual; in surging the chain leave plenty of slack chain outside for working. Now clear the chain with slue-ropes on the anchor stock and slip-ropes on the chain. It may be necessary to unshackle in clearing; if so, hang the cable before unshackling, clear the turns and shackle again.

If the cat cannot be hooked in the ring, then hook it to a stout strap around the shank, just under the stock, cat and proceed as before, passing the ring-stopper.

Anchor *comes up crown first*. Cat the crown by hooking the cat to a strap around the crown, and pass the ring-stopper

over the crown, unhooking the cat. Now clear, if necessary by unshackling the chain, having plenty of slip-ropes to take its weight. Hook the cat in the ring and the fish in the arm, take the strain on the cat, ease away the ring-stopper, and haul away on cat and fish.

It might be advisable, with the anchor coming up crown first, to hook the fish *first* to a strap on the crown, hauling on it till the ring could be reached to hook the cat, then, easing (and unhooking) the fish, catting the anchor, clearing the turns and fishing it. The whole depends upon the circumstances, as above stated; and the latter operation in particular, presupposes that there is not too much drift to the fish, and that the fish gear is reliable, it being smaller than the cat.

For anchor work, "clear hawse breeches" are made, of painted canvas, wooden soled at the feet, and slung with spans long enough to clear the man's head.

Marking the cable so as to know exactly how much to surge for catting saves noise and delay, but greater allowance must be made when "foul anchor" is reported.

Buoys and Buoy-Ropes. Buoys attached by their buoy-ropes to the crown, point out at all times the situation of the anchor. The *can* buoy is in the form of a cone, it floats base uppermost, and the rope is attached to the apex. The *nun* buoy is largest at the centre, tapering at the ends. The latter is in general use. Fig. 434, Plate 92.

The size of *buoy-ropes* is one-third of the cable. The length varies, for it is shortened or lengthened according to the depth of the water in which you will drop the anchor.

It is bent to the crown of the anchor, by taking a half-hitch around one arm, and putting the running eye in its end over the other arm; or a clove-hitch is formed over the crown, and the end stopped along the shank, or to its own part. Or,

Attach a large thimble to the crown of the anchor, by a stout strap of the size of the buoy-rope (one-third the cable). Through this thimble is rove the buoy-rope, both parts leading up to the buoy. The advantage of this is, that the buoy-rope may be smaller, and when necessary, a stout rope of the required size, may be, by it, rove through this thimble in the crown of the anchor, thereby affording a greater purchase than

that of a single rope, for weighing.

The only objection to this plan is, that the two parts of the small buoy-rope will become *hawser-laid*, and will not unreeve. But this may be, in a great measure, remedied by having one part plain-laid and the other back-handed rope.

Sometimes a buoy will not *watch*, from its having filled with water, or from the buoy-rope being too short, particularly in a tide-way. By this is meant, that it does not float on the surface of the water. In the former case it will be necessary to *bleed* it, that is, to let the water out. In the latter, to lengthen the buoy-rope.

Buoys are generally kept, one in each of the fore channels for common use. Spare ones are kept in the hold.

It was a very good rule, that an anchor should never be let go without a buoy attached. But since the screw propeller has been introduced, they have been less used, through fear of fouling the screw, though the end of a *chain* is always buoyed in slipping.

To Pick up Moorings from which the vessel has previously slipped. Stand in and reduce sail to topsails, or slow down if under steam, lower a boat, coil away a hawser in her and let her pick up the buoy-rope of the chain, attaching the hawser to it. Tack off shore if necessary till the boat has picked up the buoy, then stand in and round to, to windward of the buoy, signal the boat to pull alongside. Take the hawser-end in through the hawse-pipe, and run it in. As the chain comes in, make sure of enough to allow for biting, clap on stoppers forward of the bitts; bitt, and stopper abaft; then shackle as soon as possible.

To Make Fast to a Mooring Buoy. In some harbors moorings are planted for vessels to ride by, in order that they may occupy in swinging as little space as possible.

On approaching the buoy, a boat may be sent out with the hawser to make fast and return, or she may leave the ship with the end of the hawser, just after clewing up. Warp the ship up by the hawser to the buoy, unshackle the bower-chain from its anchor and shackle to the buoy, veer a few fathoms and put a *bull rope* on the buoy from the end of the bowsprit to keep it clear of the stem.

The boat which carries the warp should contain a maul, mooring-shackle, spare earing, and a tail-block. The earing is used to secure the shackle to guard against losing it overboard while shackling. The tail-

block, secured to the ring of the buoy, is for a hauling line to get the chain in position for shackling.

When picking up moorings, have an anchor ready for letting go, in case of accident.

Lying at Single Anchor, to Veer Cable, Blowing Hard. Veer away, by short drifts at a time, through the compressors and laniards of the deck-stoppers. If it is blowing a gale, with a heavy sea, it would be necessary to veer with a deck-tackle. A ship in this case, would double bitt before veering, if

required, and send down her spars, and let go other anchors as necessary.

Why we Veer Cable in Heavy Weather. It is a prevalent but fallacious notion, that, even when used in deep water and with a severe strain, the curvature or deflection of chain is considerable, and that near the anchor it rests upon the ground undisturbed by either the pitching motion of the ship, or the tension which she causes. At a testing strain of six hundred and thirty pounds per eighth-inch of circumference, the utmost deflection was found to be only ten feet upon a length of one hundred fathoms, in ten fathoms water, with the hawse-hole a fathom above the surface; the diameter of the chain being one and one-half inches, and the strain forty and one-half tons.

In a common gale, which would produce this strain, not one link of the one hundred fathoms of chain will quietly rest upon the ground; on the contrary, it will be found by the experiments on a depth of ten fathoms, that 127.98 fathoms of chain are required to form a semi-catenary* when suspended in air, and 137.03 fathoms when in water. If the strain be less, the curvature will be greater, and no danger need be apprehended; but in a severe gale, the force of which may be supposed equal to, or nearly equal to, a breaking strain, a long scope is the only way to prevent a fatal result; and any man in charge of a ship at anchor, with the necessary quantity of chain cable on board, and space astern to allow him to make use of it, but who neglects to do so, must be considered the author of his own misfortune, whether it amount to the loss of his anchor or the loss of his ship.

To Increase the Value of a Long Scope. To increase the deflection of the cable and bring the strain on the anchor, more in a horizontal direction, a heavy kedge may be shackled or lashed to the bight of the riding cable just before veering for bad weather. This is similar to "backing" an anchor.

Letting Go Additional Anchors. In preparing to ride out a gale at anchor, if the holding-ground is even moderately good, a ship will hold on longer and certainly ride easier with all her chain on two anchors, than by letting go all four anchors with comparatively short scopes. Circumstances may compel a ship to

depend for safety upon the number of anchors down, as in the case of a crowded harbor with insufficient room to veer; but with more than two anchors down, unless systematically laid out in fine weather, there is little probability of the strain being equally divided. Vessels anchored in this way

* A catenary is the curve formed by a flexible chain of uniform density and thickness when allowed to hang freely between two points.

have snapped their cables one after another from the effect of the sudden jerks upon a short scope such as a hundred fathoms would be in a gale of great severity.

Having plenty of room astern, and with four cables each 120 fathoms long, veer to 60 fathoms on the anchor down, say the starboard bower, let go the port bower. Lengthen each bower chain by the sheet chain on its side, and veer two cables on the starboard and one and a half on the port bower. There remains on board one-half the port sheet-cable available for adding 30 fathoms to each anchor down.

To use three anchors, the distribution of chain would be: starboard bower (the anchor down), with 90 fathoms of starboard sheet, the port bower lengthened by the remaining 30 fathoms of the starboard sheet chain, and a whole cable on the port sheet. Having veered to 60 fathoms on the starboard bower let go the port bower, veer 30 fathoms, and let go the port sheet. Veering to the full scope, the starboard bower would have one and three-quarter cables, port bower, one and a quarter, and port sheet, one cable. The arrangement assumes, 1st, that a scope of less than 100 fathoms is of comparatively little value; 2d, that 60 fathoms would probably be veered in any case before letting go a second anchor; 3d, that the anchors should have as nearly equal a scope as the second condition admits.

For a modern steamer with well-proportioned ground-tackle, good holding ground and plenty of room astern, the plan of using two anchors with the longest possible scope is considered the best.

Backing an Anchor. When the holding ground is bad an anchor may be "backed" by another.

In backing an anchor during a gale after it is down, the backing hawser or chain is taken round the riding cable and secured loosely in order that it may slide down and along it when the backing anchor is let go. A large shackle might be used for this purpose on the riding cable, and the backing chain shackled to it.

To Back an Anchor when Preparing for a Gale. Heave in or veer away on the anchor down, say starboard bower, till you bring the fourth shackle some few fathoms abaft the bits; stopper, unshackle,

and unbitt; pass the end out and shackle it to the ring of the port bower, which has been eased down to the hawse-hole; off stopper, and ride by port bower cable, with its anchor at the bows until the gale comes on, and then veer it down to the ground. Should the gale pass off, you can hang the starboard bower cable outside by the clear-hawse pendant, and replace both in their original position.

If on veering to sixty fathoms on the port bower, you found the gale still increasing, shackle the remaining sixty fathoms of the starboard bower to it; let go starboard sheet

256

anchor, and veer away on both. Finally, if compelled by the violence of the storm to make the utmost of your resources, divide the remaining sheet chain between the port bower and starboard sheet. There will then be sixty fathoms between the starboard bower and the backing anchor; two hundred and forty fathoms on the port bower, and one hundred and eighty on the starboard sheet.

Anchors have been backed by vessels on a lee shore, with some of the guns. Stout hawsers were passed through the hawse holes (or bow ports) on each side, underneath the cables, the ends brought in to the after-most guns used, clinched there at the cascables and lashed near the muzzles; the bight of each hawser passed in the port and on top of the gun next forward, under the cascable, and lashed at the cascable and muzzle, and so on forward, leaving sufficient slack between each gun, so that they can be thrown overboard one at a time, commencing aft. When they are all overboard bend on other hawsers and veer away, *without attempting to ride by them as the ship drags*. The anchors having dragged to the place where the guns were thrown overboard, may bring up the ship by the flukes of the anchors catching the bights of the hawsers. The lowering hawsers are buoyed.

To Weigh Guns thrown overboard in this manner, having hove in on the cables until the berth of the guns is reached, pass the buoyed end of the hawser through the warping chock in the bridle port, and heave up the first gun with a suitable purchase on the hawser. Land the gun in the launch hauled up under the bows, using the cat-fall if necessary. Drop the launch to the gangway, sling the gun and hoist it in with the yard-tackle and garnet, continuing the operation until the guns are all in. Or get in the guns as described page 233.

Steaming up to Anchors. When riding out a gale at anchor, steamers relieve their ground-tackle by turning the engines. But care must be taken not to overrun the cables, as in that case, when the ship goes astern to a fresh squall, the violent strain on the chains would probably part them or start the anchors.

With Four Anchors Down, to Weigh. If the scant room in a harbor or its crowded condition has compelled us to ride out a gale with four anchors and short scopes, the anchors were probably let go in the

following order: First, one bower (say starboard), then after veering 45 fathoms the port bower, veer 15 fathoms and let go the starboard sheet, veer 15 fathoms more and finally let go the port sheet. If there is room enough, two sections from the port sheet added to the starboard bower would give you a final scope of 150 fathoms on the starboard bower, 105 on the port, 90 on the starboard sheet, and 75 on the port sheet.

To weigh, assuming the cables to be clear, bring the port sheet to the capstan, clap a deck tackle on the starboard sheet, and while heaving in get as much slack as possible of the two bower chains. Weigh the port sheet first, then bring the starboard sheet cable to the capstan and weigh the starboard sheet.

Having weighed both sheets, which should be done first, transport them to where they stow. Then weigh the port bower, taking in the slack of the starboard bower chain.

A vessel would perhaps be more than one day in picking up her anchors as described, particularly if the sheet anchors stow in the waist or if she has *swung and fouled her hawse*. In such cases much time will be required to clear the cables and weigh the anchors. In case you are unable to clear the cables, the anchors must be weighed by the launch, and a hawser bent to that end of the chain, which will then be slipped by the launch, and hove in from the ship. No particular rules can be given for such cases.

When a ship has let go two or more anchors, in a gale, she should weigh her anchors *as soon as the gale moderates*; much trouble will be saved by it.

A Collier's Purchase. In heavy heaving, a strap may be put on the cable at the water's edge, hook the cat in it and assist in that manner. This is known as a collier's purchase. The fish may be clapped on to the cat-fall and taken to the capstan.

To Assist in Heavy Heaving. Put a large block on the cable, near the hawse-hole, reeve a hawser through it, belay one end to the mainmast or bitts, and clap a deck-tackle on the other end; or take it to the after-capstan.

Some vessels (brigs and small sloops) use the deck-tackle entirely in weighing their anchors.

In using a deck-tackle, particularly in a large ship, much time is saved by having a whip from forward to assist in *overhauling* it.

To Anchor by the Stern. This may be necessary for a steamer in a narrow harbor, where the vessel is too long to turn, or in a stream where there is no room for swinging to the tide. The British at the battle of the Nile anchored in this way to avoid raking broadsides in rounding to; the French also anchored by the stern at Sebastopol.

As ships are not always provided with appliances for anchoring in this way, it would be well to use the stream anchor and chain, or a hawser, in performing the evolution, if it will stand the strain expected.

Get up the stream-chain, rouse it out through the after-port, haul it forward outside of all till abreast of the hatch where the anchor is stowed, then hoist out the anchor,

shackle the chain, and let go with a strap and squilgee, or ease the anchor down to the bottom with the bight of a hawser.

Or, transport the stream-anchor to the cat-head or stern, as may be most convenient, shackle the chain there and let go.

To use a heavier anchor, rouse up the sheet-chain from below, pass it through the after-port, haul the end forward by a ring-rope to the sheet-anchor and shackle. Range the intended scope of chain on deck. In the absence of afterbitts, ring-bolts, &c., have plenty of stoppers and lashings passed; a stout hawser from the forward bitts, with a couple of turns taken round the mainmast, will relieve the compressor of some of the strain when the end of the scope is reached; the cable itself might be taken around the mizzen-mast. Stop the engine, or clew up and furl in good time, and check the cable as much as possible in running out.

In all cases of anchoring by the stern, or with springs from aft, use *slip-ropes* to avoid injury to the rudder or screw.

To Anchor with a Spring. Rouse up the stream-chain (or a hawser), haul it aft, as in anchoring by the stern, and thence through the after-port forward, secure the spring to the bower, keeping the bower-chain bent; then let go the bower. Now, by setting taut the stream-chain and veering on the cable, the ship's broadside is sprung around. Ships may be sprung broadside to the wind, in warm climates, for the purpose of better ventilation; or in engagements at anchor, to bring the guns to bear on various points.

Using a spring from the bower anchor or cable, for the purpose of getting a ship's broadside to bear *steadily* on any object, can never be equal to the steadiness acquired by using a *second* anchor, with a

stream-cable or hawser. A spring is at all times little to be relied on, compared with a stern anchor, and after it becomes dark, a spring will much decrease the certainty of gun practice. If a ship has a good scope of cable with one anchor ahead and the other astern, rather tautly moored, and her broadside bearing well on the object, there will be little fear of her sheering about much. But should it be requisite to fire at night by previous bearings, then, to make the practice more certain, it would be well to have two kedges, with two good, strong hawsers laid out on the off side, one on the bow and the other on the quarter; the hawser from aft being attached to the anchor on the bow, and the one from forward to the anchor on the quarter; these two hawsers crossing each other at a good angle, with as much scope as possible, well_ bowsed taut, will insure the direction of the guns.

THE "SARATOGA" AT THE BATTLE ON LAKE CHAMPLAIN.

As the success of the "Saratoga," in this action, was mainly due to the superior seamanship of her officers, as evinced by the manner of working her kedges and hawsers, a brief description of that part of the action may be instructive, since we are told that the "Confiance" (English), with but one spring on her cable, got just so far round as to hang while exposed to a raking, while the "Saratoga" was "entirely successful, springing her broadside successively on every vessel wearing the British flag."

The American vessels had each its stream-anchor hung over the stern, the cable bent ready for use; and besides the usual springs, the "Saratoga" had a kedge planted broad off each bow, the hawser of each leading in through the quarter ports, the bights hanging in the water. In the midst of the fight, on firing the only gun (a carronade) remaining mounted in the starboard battery of the "Saratoga," the navel bolt broke and the gun flew down the main hatch. The attempt was then made to wind the ship. Fig. 433, Plate 92.

To this end the stream-anchor astern was let go, and clapping on the starboard quarter line, the ship was roused over to the kedge on that side; line had been bent to the bight of the stream-cable, and she now lay with her stern to the raking broadside of the "Linnet" (position 2, Fig. 433, Plate 92), being for a brief space in a critical position, but dipping the port quarter line under the bows, it was passed aft to the starboard quarter, the ship's stern sprung to the westward, and the port battery brought to bear on the enemy.

Having anchored with a spring to the stern, to heave up. If the ship is still riding by the stern cable, heave in the bower, veer away the stern cable, set the spanker, and wind the ship. Hang the stern cable outside (or stopper it); pass a stout hawser out of the sheet hawse-hole; pass the end aft, outside of everything, and bend it to the stern cable at the nearest shackle. Unshackle, and let the cable go; man the hawser, and walk the cable in through the hawse-hole. When taut in, clap a deck-tackle on it, take the

bower cable to the capstan and heave round. Walk away with the deck-tackle as the bower chain comes in. When the anchor is up, unshackle or unbend the spring and haul it inboard out of the way.

To Slip a Chain. In preparing to slip, put a buoy-rope on the chain, stout enough to weigh it, lead the buoy-rope out through the hawse-pipe and to the fore-chains,

260

where it is made fast to a smaller line, equal to the depth of water, and bent on to the buoy. The buoy sustaining only the weight of the small line, can then *watch* properly.

Stopper the cable forward of the bitts, or heave down the forward compressor; have the shackle well abaft the bitts. Unshackle, stream the buoy, and slip by cutting the stopper or heaving up the compressor.

In slipping, give a turn or two of the propeller astern before starting ahead, to ensure clearing the buoy-rope.

Plate 96

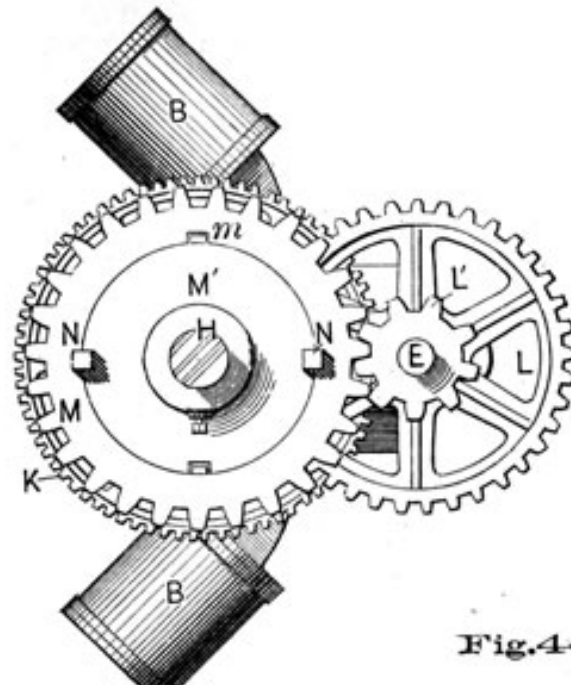


Fig.443

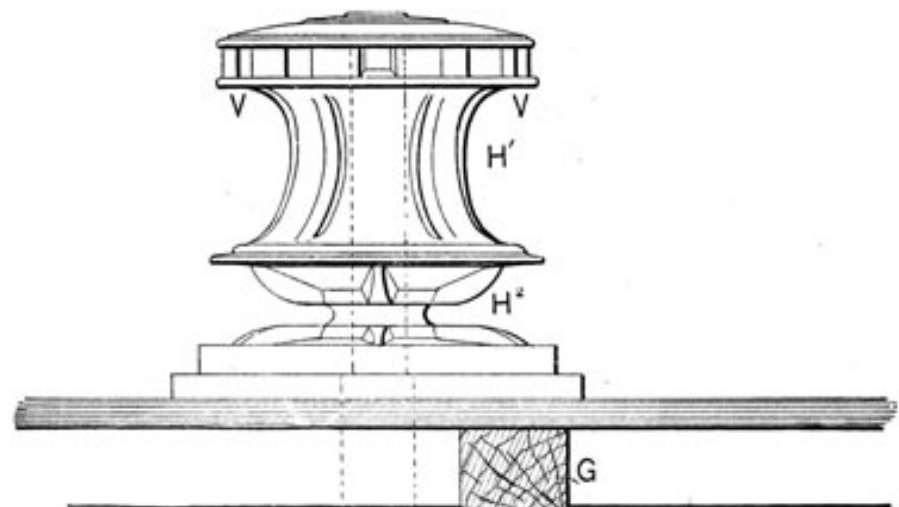
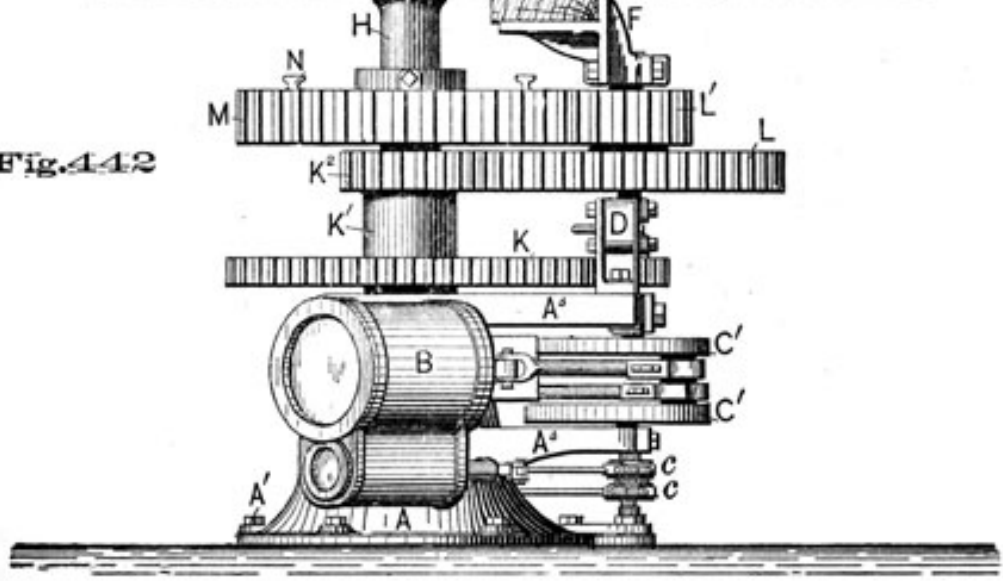


Fig.442



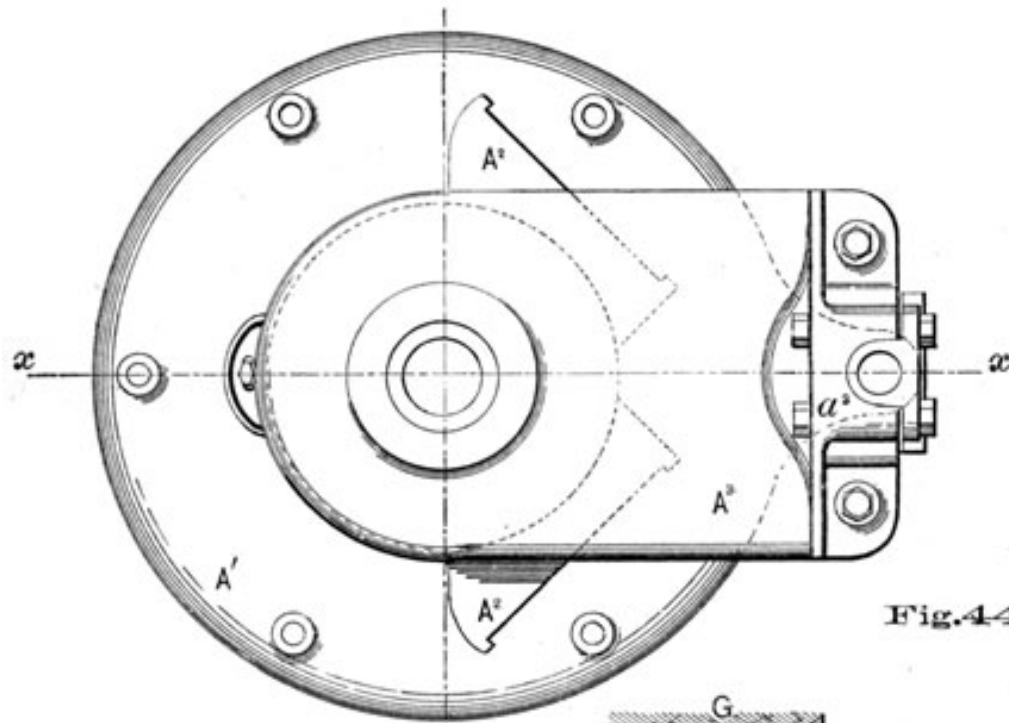


Fig. 445

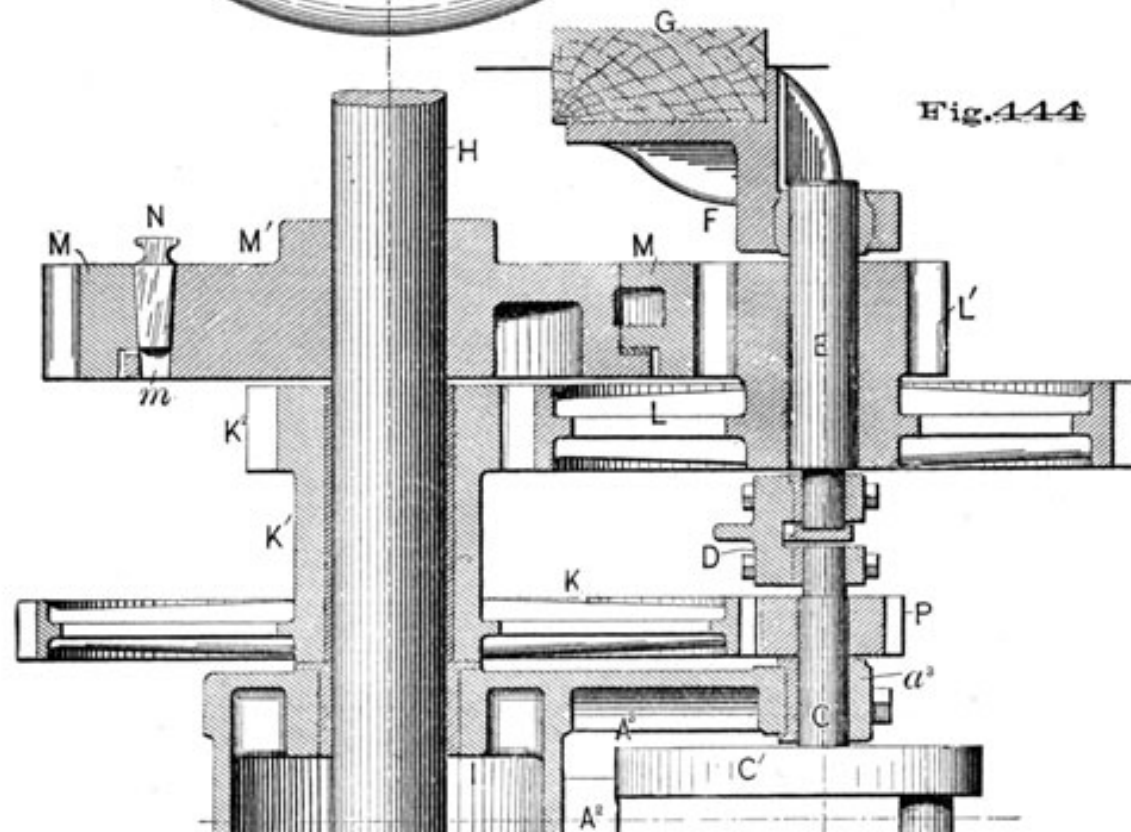
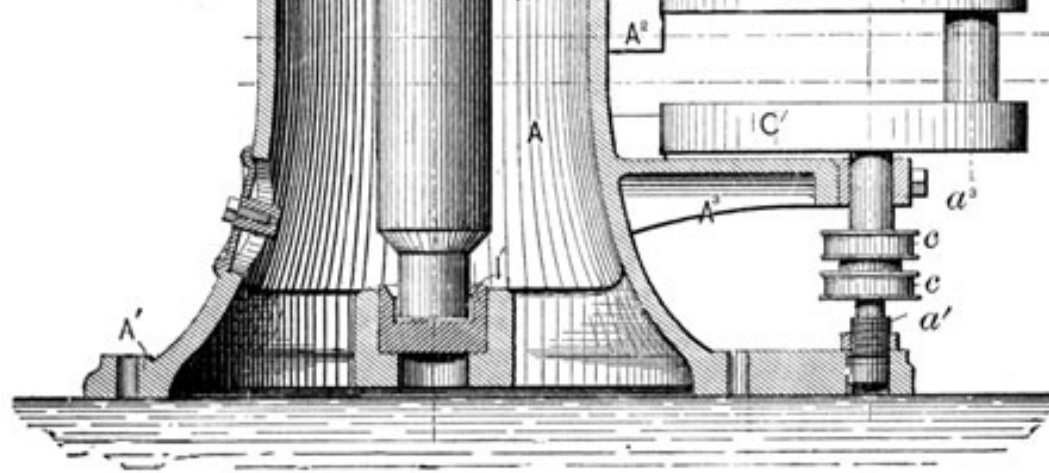


Fig. 444



CHAPTER XV.

STEAM CAPSTAN-STEAM WINDLASS.

In modern vessels, steam power is made available for handling the capstans or other appliances used for weighing anchor, to the great saving of labor.

H. J. Johnson's patent capstan, Plates 96 and 97, is the one now fitted on board the U.S.S. Lancaster and other vessels, and may be described as follows:

Fig. 442 is a side view of the entire machine. Fig. 443 is a top view of the machine as it appears after the removal of the capstan, wild-cat, and deck on which they are placed. Fig. 444 is a vertical section, on line *x x* of Fig. 445, of that part of the machine below the deck on which the capstan is placed; and Fig. 445 is a top view of the bed-piece for supporting the cylinders, the lower end of the capstan-spindle, and the independent gear-shaft.

In said drawings, A represents the bed-piece of the machine. It is a bell-shaped hollow casting, formed with a bottom flange, A¹, provided with a series of holes to receive bolts to secure it to a ship's deck. There is formed upon two sides of said bell-shaped casting, A, large lugs, A², made with the vertical outer face of each set at an angle of ninety degrees to the other; and to these lugs the steam cylinders B are bolted, and thus remain suspended. From the side of the bed-piece, A, there is also projecting, one above the other, two large brackets, A³, to support the two bearings, a³, of the vertical crank-shaft, C, of the engine. Its crank portion, C¹, being close to and between the two brackets A³, is thus properly sustained. The lower end of the crank-shaft, C, rests in an adjustable step, a¹, secured to an extension of the bottom flange, A¹, of the bed-piece. The upper end of the crank-shaft, C, is retained in bearings in a bracket, D,

secured to the top of the upper one of the brackets, A³. This bracket, D, also carries the bearings for the lower end of an independent shaft, E, placed directly above and in line with the axis of the crank-shaft, C. The upper end of the shaft, E, is retained in bearings supported by a bracket, F, that is bolted to the under side of the deck-beam, G.

The capstan-spindle, H, to which is secured the capstan, H', and the wild-cat, H², is retained vertically by bearings,

262

I, in the top of the bed-piece, A, and has its lower end supported in a bearing-step, I', attached to transverse ribs in the interior of and forming part of the bottom of the bell-shaped bed-piece, A. Upon the capstan-spindle, H, there is placed directly above the top of the bed-piece, A, the large gear-wheel, K, having the lower end of its hub resting upon the bearing, I. This gear, K, has a long hub or sleeve, K', attached thereto, or preferably cast therewith, and the upper end of this hub carries a pinion, K², to mesh with a large gear-wheel, L, secured to the independent shaft, E.

The gear, K, pinion, K², and connecting hub, K', are mounted loosely upon the capstan-spindle, H, and are, free to turn thereon at a different speed from the latter.

Upon the hub of the large gear-wheel, L, there is mounted, or preferably cast therewith, a pinion, L', keyed or otherwise secured to the shaft, E.

The rim-wheel, M, is connected with its hub, M', by means of slightly-tapering keys, N, inserted in perforations, *m*, made correspondingly in the inner periphery of the rim-wheel and the outer periphery of its central portion or hub. When the keys, N, are removed, the central portion, M', is disconnected from its cogged rim, and will revolve with the capstan-spindle, H, when the latter is rotated by turning the capstan and its wild-cat by hand, while the engine and its train of gears remain stationary.

The crank-shaft, C, carries on its lower portion the eccentrics, *c*, operating the slide-valves of the engines. It carries also, near its top, the pinion, P, that transmits the rotating motion of the crank-shaft to the transmitting gear, K, running loosely around the capstan-spindle, as above stated, and motion is transmitted from the pinion, K², on the hub of the gear, K, successively to the gear-wheel, L, pinion, L', and rim-wheel, M, and through the hub, M', of the latter to the capstan-spindle when the keys, N, are in position, the power of the engine being multiplied according to the relative size of the gear-wheels and the pinions gearing with them.

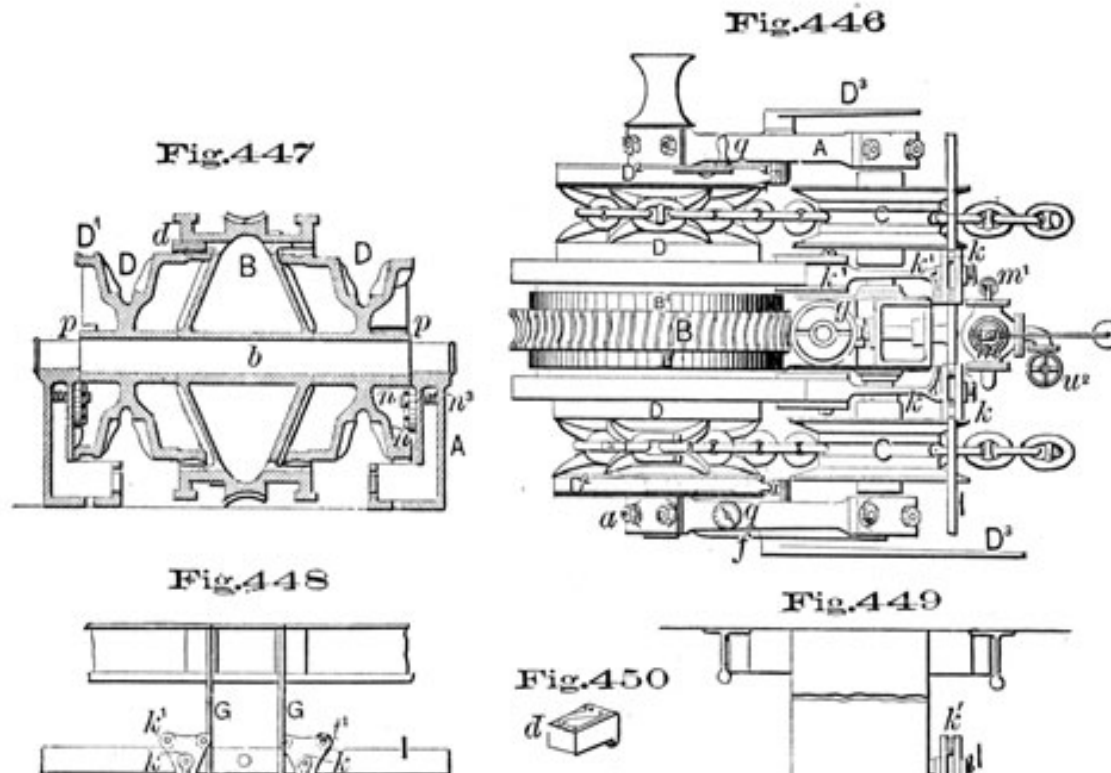
The engines are made, as shown in the drawings, to be operated with slide-valves, and have a reversing-valve attached, and other appliances commonly used in steam-engines.

From the description, it is evident that the general action of the steam capstan is similar to that of an ordinary hand capstan. But one chain can be hove in at a time. In case of there being no steam up, the removal of the keys, N, place the capstan at once in condition to be revolved by the usual capstan-bars shipped in the pigeon-holes, V, V.

Steam Windlass. Instead of a steam capstan, some vessels are fitted with Sickel's Power and Hand Windlass.

The following description and accompanying drawings

Plate 98



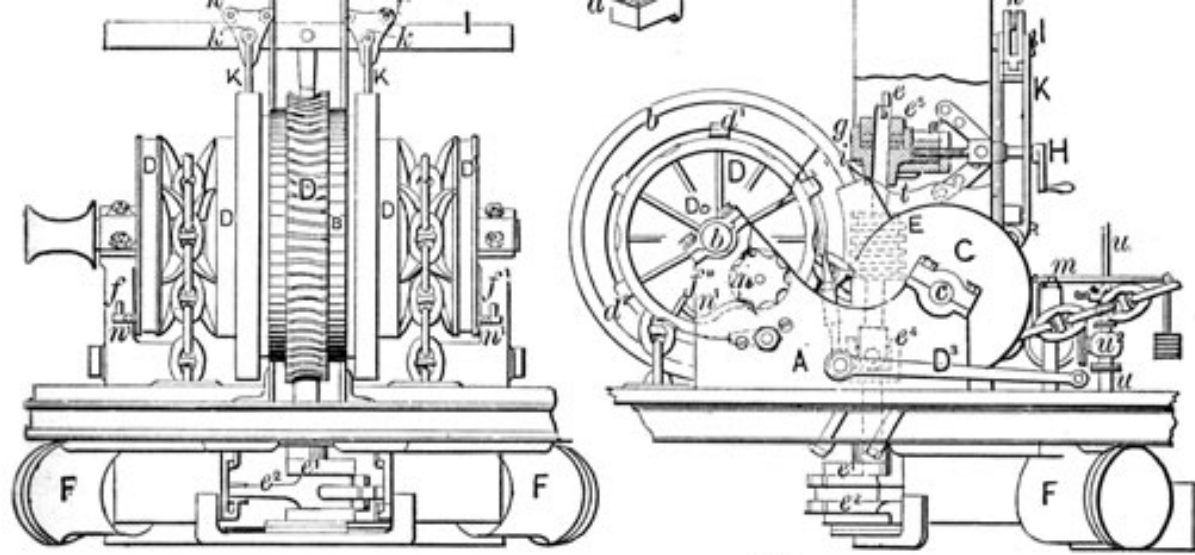


Fig. 451



Fig. 452

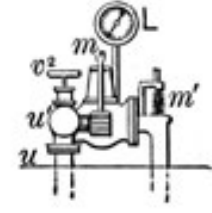


Fig. 453

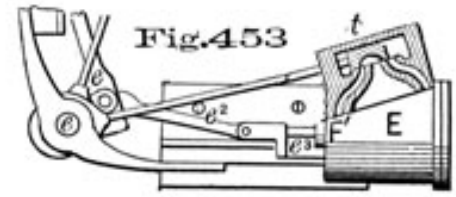


Plate 99

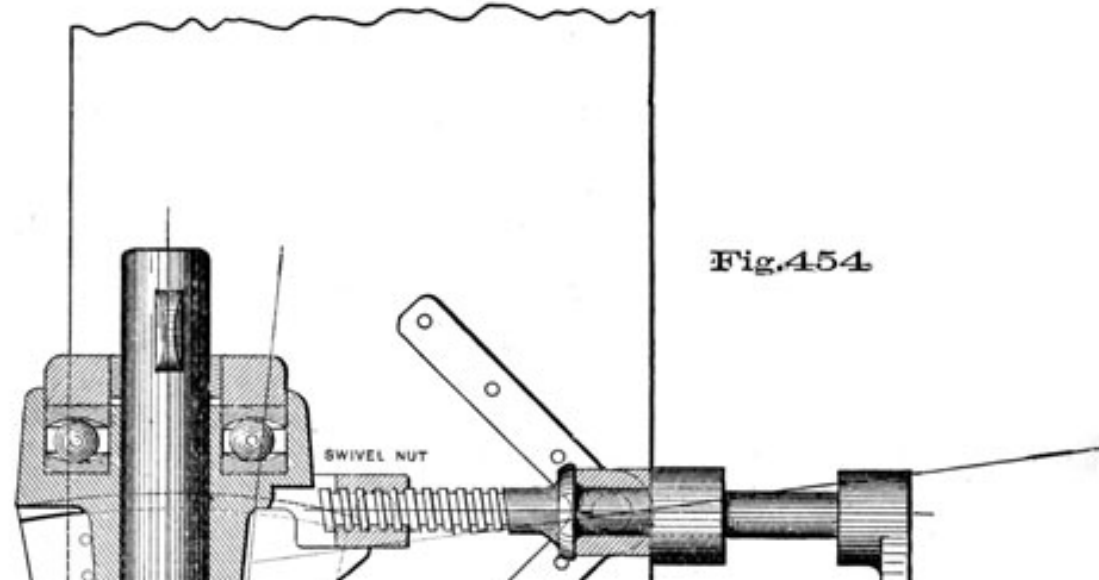
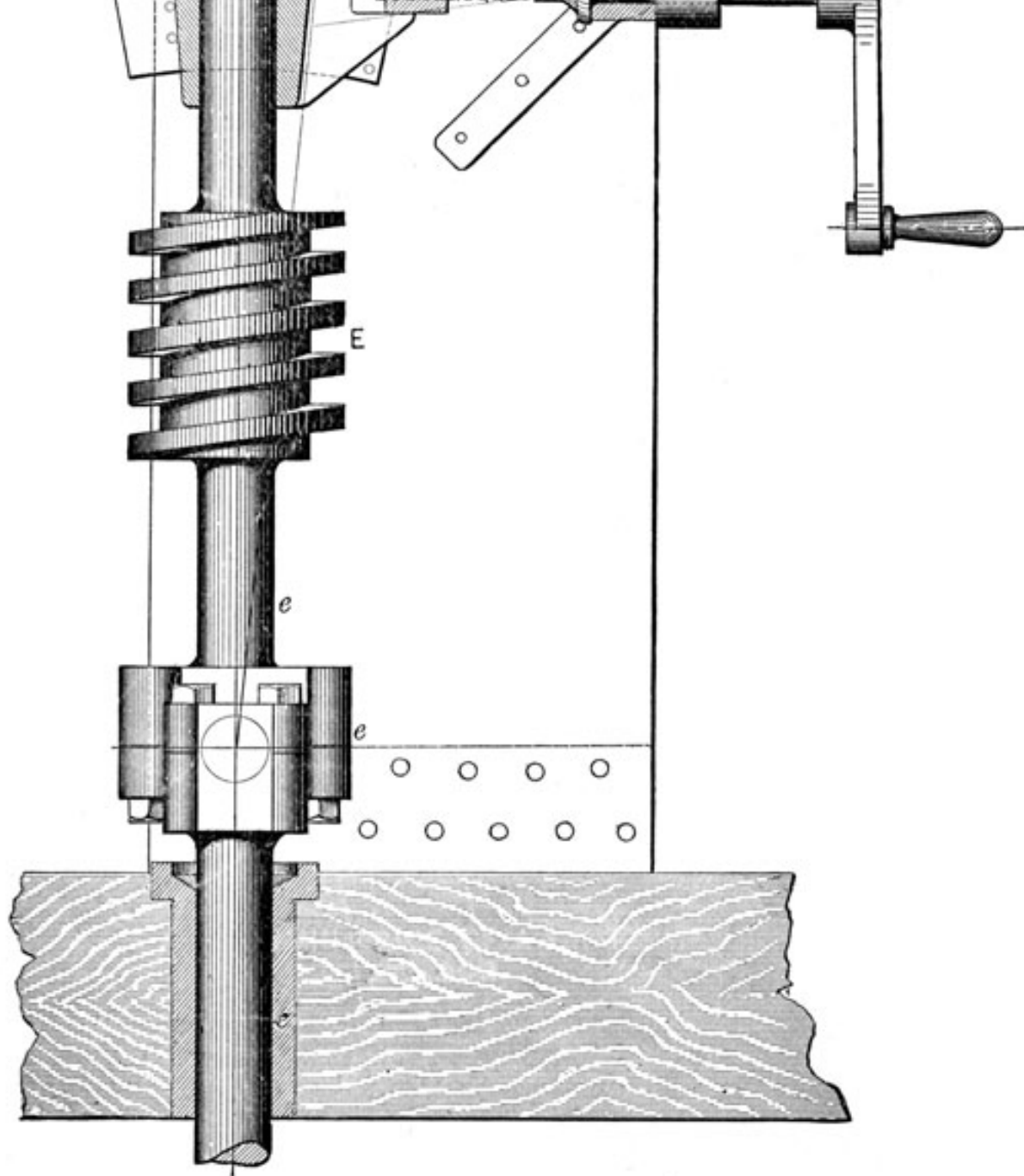


Fig. 454



show the steam windlass as now fitted on board the U.S.S. "Trenton," Plates 98 and 99

Figure 446 represents a top view of the windlass. Fig. 447 represents a vertical section through the main gearwheel and the wild-cats or ribbed pulleys. Fig. 448 represents a rear elevation of the windlass and its connection with the steam-cylinders. Fig. 449 represents a side elevation of the same, partly in section, to show parts in the interior of the frame. Fig. 450 represents, in perspective, one of the keys used to connect the main driving-gear with either of the wild-cats. Fig. 451 represents a portion of an anchor chain, with a shackle uniting two sections of chain. Fig. 452 represents, in front view, the main steam and automatic pressure-regulating valves and spring-valve, and the indicator of tension upon the anchor chain. Fig. 453 represents a bottom view, partly in section, of one of the cylinders, steam chest, and connections used to operate the windlass by steam-power.

Similar letters of reference, where they occur, denote like parts in all the figures.

The pressure of steam is limited by an automatic pressure-regulating valve, so that if the anchor chain fouls while the engine is running rapidly, it will stop before breaking it or any other part. The shackle and shackle-links at the ends of each length of chain are fitted to the wild-cats, so that they will engage with the stops or ribs, in the same manner as the other links, without mounting the ribs and slipping. Spring-keys are used to connect the wild-cats with the windlass. These keys are placed into square recesses cut out of both the wild-cats and windlass. These recesses extend through the windlass, so as to admit a bar to back out or remove the keys.

The worm-wheel pinion connecting the engines with the windlass is placed on a vibrating rotary shaft, so as to be drawn out of gear to disconnect the engines from the windlass.

The standards for sustaining the hand-power brake are made of wrought-iron plates at such distance apart as to inclose the worm-wheel pinion, and form a column between decks to resist strains of tension as well as of compression.

A spring-valve is used in connection with an automatic pressure-regulating valve, so as to insure perfect safety, even if the latter should stick while open and be inoperative.

The position of the anchors is indicated by a separate counter connected to each wild-cat, so as to register as well in paying out as in taking in the anchor chain.

The eccentrics are set on the engine-shaft, so as to operate the slide-valve of each steam-chest, and keep the exhaust-port open until the piston has reached the ends of the cylinder to avoid the use of water-cocks, and so that

they can be started and operated from the different decks by any inexperienced person without requiring, the operator to go to the engine to let out condensed water, the admission of steam being delayed until the engine has passed the centre.

In the drawings, A represents the frame that supports the shaft *b* of the windlass B, and the shaft *c* passing through the axis of the guiding-pulleys C. The frame A is securely bolted to the deck by diagonal bolts *a* and other bolts. Upon the central portion of the shaft *b* the windlass B is mounted. It has a concave gear-wheel with slightly bevel teeth formed upon its periphery, to engage, when desired, with a worm-wheel, E, mounted upon a shaft, *e*, that is connected by means of cranks *e*¹ and connecting-rods *e*² with the piston-rods *e*³ and pistons of the steam-cylinders F. The shaft *b* carries also two wild-cat pulleys, D, loose upon said shaft and free to revolve, except when connected with the windlass B by keys *d*, introduced into openings *d'*, formed partly into the flange of the windlass and partly in the rim of each wild-cat. The openings *d'* extend through to the opposite side. The opening there may be made partly circular, and too small to receive one of the keys *d*, but large enough to receive a crow-bar or hand-spike, *f*, with which the keys *d* can be pushed out of the opening *d'* from the opposite side from which they have been introduced, and either of the wild-cat pulleys rendered free to revolve independent of the windlass, upon each side of which the opening *d'* may be made alternately rectangular and semicircular. The keys *d* are provided with springs, so that they cannot drop accidentally out of the openings *d'*, but must be forcibly pulled or pushed out. Each wild-cat pulley is formed with a groove, D¹, to receive a brake-band, D², that is connected with a brake-lever, D³, placed on the side of the frame to save room, and remains connected with said band D².

The worm-wheel E and its shaft *e* are made in one piece and inclined, so as to adapt the mechanism to steam or hand power. For this purpose the shaft *e* is formed of two lengths, connected by a universal joint, *e*⁴. The shaft was formerly supported at its upper end by a key, *e*⁵, passing through said shaft, and resting upon washers carried in a cup-bearing, *g*, as shown in Fig. 449. This bearing *g* rested upon plates *i*, attached to, and projecting from, the inside of the wrought-iron standards G, and was moved back and forth by means of the hand-crank H, operating a screw, *h*, engaging with a nut, *g'*, carried by the bearing *g*. In future the bearing for the upper end of the shaft *e* is to be fitted as shown in Fig. 454. Steel balls replace the friction plates. The bearing itself is now supported by angle irons, Z (see enlarged view, Fig. 454), upon either side, bent to a radius from the universal joint, thus permitting the screw working

in the swivel-nut to draw the worm E out of gear. Then the worm-wheel E can be placed in gear with the windlass, and be operated by steam-power, by means of the crank H bringing the worm-wheel E in gear with the windlass B. The windlass is provided with ratchet-gears B', with which retaining pauls engage, in the usual manner. When the worm-wheel E is thrown out of gear with the windlass through the medium of the handle H, the windlass can be operated by hand by means of the double oscillating brake or lever I (united to ordinary hand-brakes), working upon connecting-rods K, and the latter operating upon levers K', one end of which clamps the rim of the windlass B. The upper end of each of the connecting-rods K is pivoted to blocks *k*, that completely embrace the end lever I; and said blocks *k* can be shifted without any effort, as they are provided with friction-rollers, *k'*, and can be clamped upon the lever I in any desired position, to vary the leverage according to the weight that is to be lifted.

When operating the windlass by steam, the pressure marked upon the steam-gauge or indicator L will correspond with the strain in tons borne by the anchor-chain, according to the area of the steam-pistons and their relative motion compared with the motion of the chain. Thus the size of the steam-cylinder can be varied so that for each increase of one pound of pressure, as shown upon the gauge, the increase of the strain upon the cable may be one ton, two tons, &c., as may be desired.

The automatic regulating-valve *m* is made with a piston loaded to the desired pressure, and connected, to a balance-valve that will, in its upward movement, close, and prevent the further admission of steam to the cylinders F, when the desired pressure is reached. To further insure a safe limit to the strain on the cable, the steam-pipe between the automatic regulating-valve *m* and the cylinder F is provided with a valve, *m'*, loaded to blow off in case the automatic regulating-valve sticks open.

The position of the anchors is indicated by a separate counter connected to each wild-cat, either in paying out or heaving in the cable. Each counter is composed of a star-wheel, *n*, with preferably ten V-shaped teeth and indentations, with one of which a pin, *p*, carried by each wild-cat or its hub, engages at each revolution, and a spring, *n*¹, retains the star-wheel immovable, except when advanced or retracted by the pin *p*. This star-wheel *n* and a corresponding wheel, *n*², upon which ten consecutive numbers are placed, are mounted together upon a short shaft, carrying a worm-wheel, *n*³, through which the number of revolutions made by the star-wheel are transmitted to an indicator, *q*, placed upon the frame A, said frame carrying also the star-wheel *n* and its retaining spring, *n*¹.

Anchor-chains are made in lengths of fifteen fathoms,

that are united by shackles. These shackles, as now made and connected to the end links of each section of chain, give an increased length between the outer ends of the adjoining links. When so made they are liable to mount the stops and cause the chain to slip, when it only passes over the top of the wild-cat, and does not embrace a large proportion of its circumference. The shackle *r* is made short, as shown in Fig. 451, to have the distance between the outer ends of the end links *s s* united by the shackle, substantially of the same length as any three consecutive links of the chain, so that they will engage the wild-cat in the same manner as other portions of the chain.

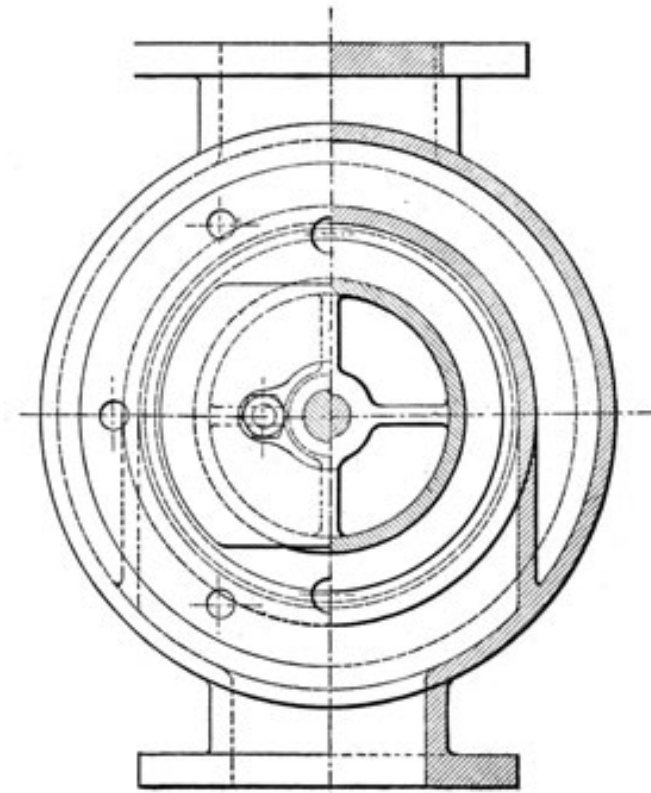
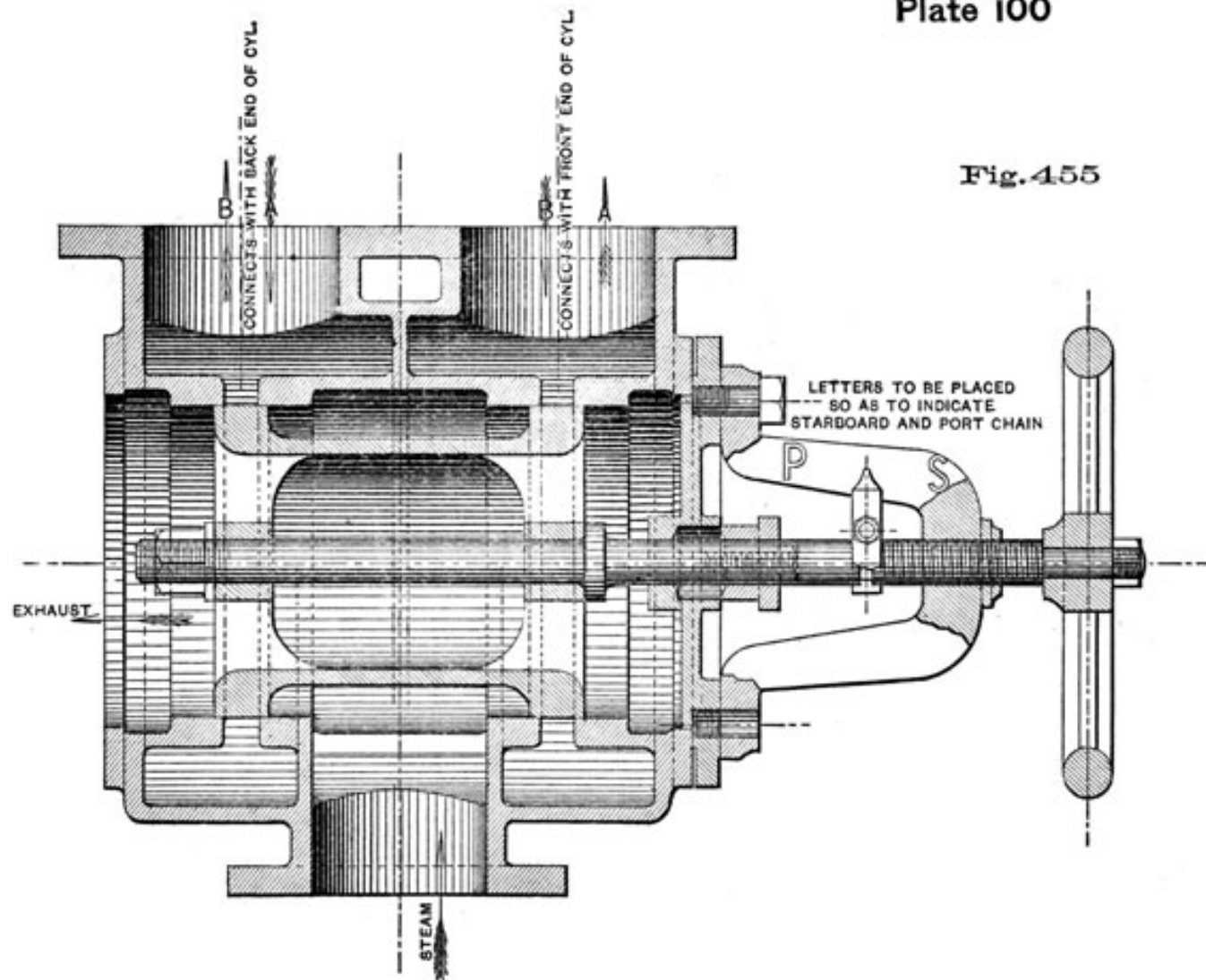
The slide-valve *t* of the steam-chest of each cylinder F is operated by an eccentric so set on the engine-shaft that in moving the valve *t* the exhaust-port is kept open at the end F' of the cylinder until the piston has reached its extreme position at that end; and the same operation is repeated at the other end. To facilitate the said operation, the slide-valve *t* may be made with an exhaust-port larger than it is commonly made for effective steam-engines, so as to keep the exhaust-port open until each engine has passed its centre respectively, and allow any water that may be in the cylinder to escape; and even if a small portion of the steam is wasted, this disadvantage is well overbalanced by the convenience of having the engine started and operated from the deck above by any unskilled hand without danger of accidents.

When it is desired to operate the windlass by steam-power, the worm-wheel E is pushed into gear with the windlass by turning the crank H. Steam is then admitted to the cylinders F from the boiler through the pipe *u* and cock *u*¹ by means of the hand-wheel *u*², or from the deck above with a vertical rod, *u*³, extending upward from the hand-wheel *u*². After steam has been admitted, its pressure is regulated by the valve in, that is loaded to blow off before there is any danger to the cables from too great tension. If steam is not to be used, the worm-wheel is disconnected from the windlass by inclining the shaft *e* forward with the screw *h*, revolved by the crank H, and the apparatus is in condition to be operated by the oscillating lever I, attached to the connecting-rods K, and the latter with the clamping-levers K', that embrace the rim of the windlass B.

It is often desired, when preparing to let go an anchor, to have a few fathoms of chain lying next to the hawse-hole. For this purpose the chain may be passed over either wild-cat by revolving the latter with the hand-spike *f*, resting upon the horns *f'* as a fulcrum, its extremity passing against the outer ribs of the wild-cat pulley D.

The above description of steam windlass has been recently improved by the addition of a reversing-valve, Fig. 455, Plate 100, which will permit the machine to be

Fig. 455



REVERSING VALVE
FOR
STEAM CAPSTANS

revolved in either direction, due attention being given to the position of the pauls.

In using this windlass, the engine can be started or operated by one person from either deck, without danger of accidents. By extending the main shaft beyond the frame, a small gypsey can be attached, so the power of the windlass may be used for any purpose, as handling the ship at dock.

This machine has been thoroughly tested, and possesses the advantages of compactness in occupying the smallest possible space, and a design giving great strength with little weight of machine.

It can be readily and efficiently operated by any seaman. The engines can be instantly started without previous preparation.

It is fully protected from undue or dangerous strains by means of its self-acting regulating-valve.

The chain being fitted with the shackles, as shown in Fig. 451, will pass freely over the wild-cats in either direction.

CHAPTER XVI.

MOORING-CLEARING HAWSE.

IN speaking of a vessel as moored, we may refer to the use of fixed moorings in a harbor or alongside of a wharf; or the ship may be "moored" head and stern. But the expression, as generally understood, means (when her own ground-tackle is used) that the ship has two anchors down in opposite directions from the vessel, one cable having been made rather taut before the second anchor was let go, and there being an equal scope on each chain.

If a ship lets go her single anchor (say in 5 fathoms), in the very centre of a harbor, which we will call about 200 fathoms wide, and "steep to," all around, and then veers 100 fathoms of cable, she would occupy every part of the harbor, as the wind or current happened to move her.

If it be desired to keep her stationary in the centre, shortening the cable in to 5 fathoms would not effect it, for the first puff of wind would cause her to start her anchor.

But let us ascertain from what quarter the prevailing heaviest wind blows; weigh, haul over, and let go an anchor in that direction, 60 fathoms from the centre; then, with a warp, haul the ship over in the very opposite direction, veering the cable 120 fathoms from the last position, and then let go the second

anchor. Now heave in 60 fathoms of the first cable, veering 60 fathoms on the last, and we shall have the ship moored in a stationary position in the centre of the harbor; and many other ships (suppose room on each side) may share the harbor by similar means, as shown by the full-lined ships in Fig. 456, Plate 101.

Whether we moor with a whole, or merely half a cable each way, or lay the anchors out in any direction (so long as they are in opposite ones, and one cable is moderately taut before we let go the second anchor), is of no consequence as far as concerns the principle we are considering.

Now with regard to the direction. Say that the prevailing gales are northerly, and one comes on from that quarter so heavy that we should veer cable. If the other ships have attended properly to this contingency, all may veer simultaneously without fouling each other, and the riding cable of each ship will tend straight to their weather anchors; in other words, they will all have open berths and open hawse, as shown by the dotted line ships in Fig. 456.

Plate 101

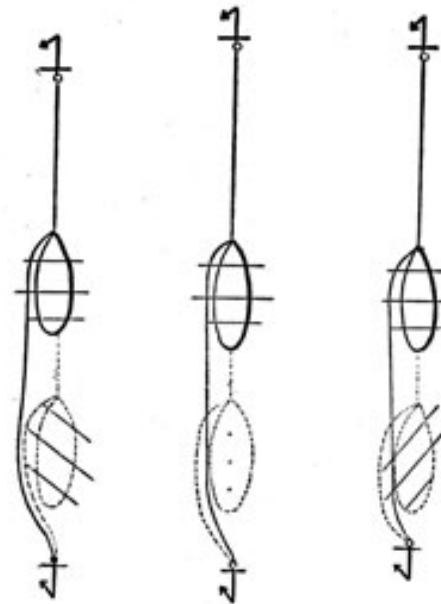
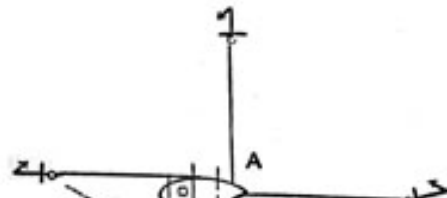


Fig. 456



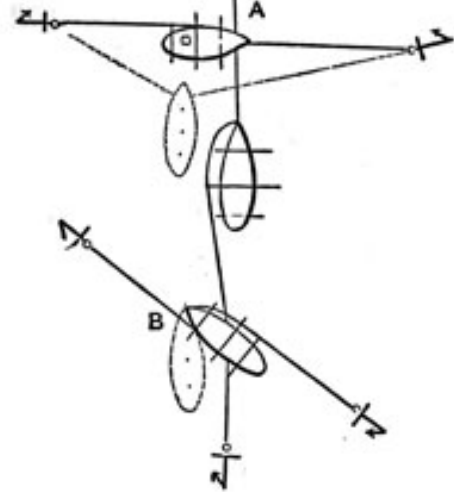


Fig. 457

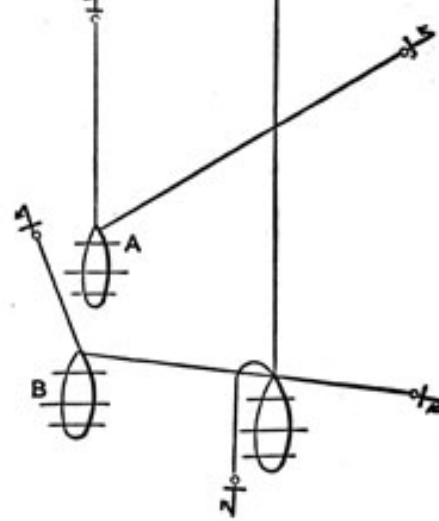


Fig. 458

Fig. 459



It is clear that with a long scope of cable, we have all the additional weight of chain in our favor, that the ship's bows are less dragged downward than at a short stay, and the pull on the anchor being horizontal, the palm bites all the harder. When we wish to make the best use of our power, we must get as close to the resistance as possible. We do not want to move the anchor; and some officers prefer veering even as much as two cables on end to letting go other anchors.

Now suppose that one or both of the other ships had moored without regard to the position of our anchors and the direction of the prevailing gales. As long as the weather was fine, and we did not want to move, it would be of no great consequence, as shown by the full-lined ships in Fig. 457.

But we want to move. B has overlaid our south anchor, and we cannot pick it up. A has overlaid our north anchor, and we cannot pick it up.

Or it comes on to blow hard from the northward, and we want to veer; but B is in our way, and we must hold on until it pleases him to veer, and he, either from neglect or ignorance in thus mooring his ship, sees no distress.

A has swung close to our port bow, as in the dotted line ship, Fig. 457, his starboard cable is sawing at our weather one; both A and B, moreover, are riding on spans, and our ship and A are much embarrassed.

At length we will suppose that B veers cable, and then that we and A veer; our new positions would be as in Fig. 458, and if a sudden lull or shift of wind occurred, the distress would be general. For we, as well as B, would have to wait for A, and B for us, before enough cable could be shortened in to keep the ships clear of each other.

Hence it is, that, when a flag officer desires to have his ships as close together as possible, he orders them to moor; and to prevent collisions while veering or picking up their anchors, he points out the direction of the anchors. To preserve, likewise, an imposing and well-dressed line, he specifies the quantity of cable that is to be veered by each, and also enforces the use of buoys, that each ship may be enabled to ascertain the position of another's anchors.

These are some, but not all, of the reasons for mooring. For instance, in a river too narrow for a ship to swing in at single anchor without grounding, or too shoal to do so without striking on the upper pee of her anchor, and perhaps settling on it as the tide fell, it would be necessary to make her a fixture. But this also would require consideration. By laying the anchors out in a line with the stream, they would be in the best position for holding, in the event of freshets or gales coming on, in concert with the tide; but, excepting the small distance she could sheer by the action of the helm, her exposure to collisions from an

enemy's fire-ships or rafts dropping down with the tide, or from vessels navigating the river, would be great; whereas, by having the anchors athwart the stream, either cable could be veered, and the ship quickly moved to one side or other.

If the water is shoaler than the ship can reach, one anchor may be carried out in a boat, and a greater scope given in consequence.

When it is optional, moor in northern latitudes with reference to the chances being strongly in favor of gales beginning at southwest, and ending at northwest.

For the same reason, in northern latitudes lie at single anchor with the *port* bower; if you have to let go the starboard anchor, you will then have open hawse.

If safety is the only consideration, and there is plenty of room to swing, a ship is obviously better off when riding at single anchor than when moored. For upon the appearance of a gale, you can veer at pleasure and be *certain* of having your second anchor in line with the wind when let go, with a long scope on each chain. A vessel which has been moored never has both cables in line with the wind, except when the ship is just between them, and therefore only riding by one, or after veering, when she lays with a very long scope on one chain, and a correspondingly short scope on the other.

When moored and veering in a gale, the anchors being in the direction of the wind, the lee cable must be shortened in to prevent dragging it over its anchor; for there is some risk of tripping the lee anchor as the weather cable is veered.

A ship should never be girt by her moorings. At such a place as Panama, for example, where the rise and fall of the tide are very great, suppose a ship were to be moored and both chains hove taut at low water. The great strain brought on her by the rising tide, provided the anchors held, may be imagined; and if, in addition to this, she should swing around several times and foul her hawse, the effect on her copper and fastenings would soon tell.

PREPARATIONS FOR MOORING, STATIONS. ETC.

All hands having been called to "moor ship," the first lieutenant takes the deck, and the other officers repair to their stations as in "bringing ship to anchor." The officer of the forecastle will see hands by the

anchor to be let go, and will give directions to those on the main deck as to veering, &c.*

* In many ships it is customary for the navigator to take charge *on the forecastle*, the senior watch officer superintending the ground-tackle on the gun-deck.

271

The navigator will see the second anchor ready for letting go, and the chain clear. Let us suppose that the starboard anchor was first let go, the port one must then be ready. He will see all clear for veering on the starboard cable, and men at their stations as in "coming to." When the starboard cable is veered as far as necessary, he will "bring to" on it, and unbitt the port one, for convenience in veering, unless in very deep water. The boatswain attends on the forecastle, and pipes as directed by the lieutenant in charge of the forecastle. The carpenter, with his crew, will ship and swifter in the capstan bars, put on gratings, knock up stanchions, &c., and report to the lieutenant in charge of main deck when ready.

The principal stations of the crew are, to man both capstans, to veer cable, on deck at the wheel, the lead, signals, by the anchor, two men in each top, a man at each mast to attend gear. Tierers below, compressor-men on berth-deck.

HAVING ANCHORED WITH THAT VIEW-TO MOOR SHIP.

The first anchor having been let go in the proper position, and with reference to the state of the hawse to prevailing winds, the first lieutenant will inform the navigator as to the scope he wishes on each chain. The navigator will veer away to double this range (supposing an equal scope on each), keeping the last shackle *abaft* the bits, for otherwise, supposing the chain well laid out, it would be mooring too taut. The mizzen topsail may be set, if necessary, and the ship sheered with it, and the helm, to the position of the second anchor. The chain must be laid well out before the second anchor is let go; when that is done (the second anchor let go), the first lieutenant directs the boatswain to call "furl sail," and having furled them, will direct him to call "moor ship." The navigator will "bring to," and the first lieutenant then commands, "HEAVE ROUND!" the stoppers are taken off (if any have been put on), when the cable is hove taut, and the chain is unbitted as it comes in, and payed below, if clean. Let us suppose that the port anchor was first let go, and that we veered ninety fathoms on it. The navigator is guided in veering the starboard cable by the amount hove in on the port; observing never to check her. Finally, veer the forty-five-fathom shackle half way between the hawse-hole and bits, and heave in the forty-five-fathom shackle on the port chain, to the same place. They will then be convenient for clearing hawse.

If the swivel is to be put on immediately, the shackles had better be kept just *outside* of the hawse-holes, unless the swivel is so small that it can be passed through the

hawse-pipe, in which case keep the shackle of the riding cable (the port one in this case) *inside* the hawse-hole. In regard to the position of the shackles, it may be well to bear in mind, if in any doubt, that it is much better to keep them too far *inside* than the other way, as cable can be *veered* by two or three hands; but to *heave it in*, requires a deck tackle and all hands.

When intending to put the swivel on, the weather cable may be veered a fathom or so more than otherwise before the lee anchor is let go, as putting it on *slacks* the chain.

If a ship is moored too *taut* she may trip her anchors in case of a foul hawse, and the cables chafe the cut-water. If moored too *slack*, the swivel will not *turn*. The navigator should look at the state of the hawse every morning, in order to assure himself that the swivel is in good order.

Some time ago, a man-of-war lying at Valparaiso, in some fifteen or twenty fathoms water, and moored with the swivel on, was unable to clear the hawse and get her anchors. The swivel had not *turned* and no attention had been paid to it. The ship was finally forced to slip her chains and leave the anchors behind, to be weighed by an anchor-hoy.

When the ship is moored with the proper scope, the navigator will put on the stoppers, and report to the first lieutenant, who then directs the boatswain to "pipe down."

The vessel is now moored with a scope of forty-five fathoms on each cable, and will swing to the wind or tide, forming a sweep within her moorings. No vessel should be moored with cables so slack, or with so little scope out, as to swing over her buoys or beyond her own moorings.

The foregoing example shows the proper course to pursue, when the spot to place the second anchor is directly to leeward of the first; but should that not be the case, she must be, by the use of hawsers taken out to the shore. or to another vessel; or by the use of a kedge, roused over to the proper spot, veering on the first cable while doing so. Then place the second anchor and proceed as just directed.

Should steam be up, of course that would be used.

TO MOOR IN A TIDEWAY.

You may veer to the full scope (ninety or one hundred and twenty fathoms) any time during the tide, and

drop the second anchor before slack water; for with a good scope of cable, and the current still running, you may give her a considerable sheer with the helm. After the second

anchor is down, bitt and stopper the cable, and wait the change of tide; when, having swung to the second anchor, you may proceed to moor as before directed.

TO MAKE A FLYING MOOR.

This manoeuvre is sometimes performed by officers, and with brilliant success, even in single-decked ships; but a satisfactory result is doubtful under such conditions.

There are two methods of making a flying moor; in either case you have first to determine in what direction the two anchors should be placed.

First Method. Have everything in readiness for anchoring and mooring, a range of one hundred and twenty fathoms of one cable, and sixty of the other, on deck; and, having made every preparation for shortening sail, approach the anchorage boldly. Clew up everything, and let go the first anchor while she has headway on sufficient to run out the whole range of one hundred and twenty fathoms. Then luff up into the wind, let go the other anchor, and proceed to heave in to an equal scope on each.

Second Method. Approach the spot where you intend to place the weather anchor, lay everything flat aback, and the moment the headway ceases, let go the first anchor, and veer to as she drops astern. Then clew up everything, and having run out the full scope of one hundred and twenty fathoms, stopper the cable and let go the other anchor. Bring to on the first and equalize the ranges. This is only proper when the places to drop the anchors are directly in the range of the wind.

In a very light air, the first anchor (in the first method) may be let go under all sail, clewing up the moment it is gone; but in a fresh breeze, and having much headway on, you should always clew up first.

As soon as the ship is moored, the *bearings* should be taken and entered on the log, together with the depth of water in which the anchors were let go, and the scope of cable out.

The state of the hawse may be known by fixing two pieces of silk thread to the compass-card in the direction of the anchors, and fastening their ends to some place above it. For every turn in the cables there will be a corresponding one in the threads.

TO MOOR HEAD AND STERN.

As there are rarely any fitments for securing stern cables we must take them to the mizzen mast, lash them to breeching

bolts in the bulwarks, or to the cradle bolts, or the mooring shackles outside.

Sometimes the ends of the stern cable are secured on shore, the bight being on board; in this case, after veering away on the bowers, and securing the stern fasts, heave ahead until moored taut enough. When using hemp cables or hawsers in this way, put plenty of good parcelling on in the wake of all chafes, and occasionally "freshen the nips," or use mats instead of parcelling.

Should four *anchors* be required, ascertain the ship's berth when moored, and mark the intended position of each anchor by small temporary buoys. Make every preparation for mooring.

Suppose the ship riding by the port bower. Plant a heavy kedge in the proper direction and haul over, or by means of a steam-tug, get the ship over to the berth of the starboard quarter anchor (starboard sheet), and let it go. This lays out in a straight line the port bower. Bring to on the latter, and heave in to the proper scope, veering carefully on the starboard quarter chain. The work is now half done. The other two anchors may be planted by either of the following methods:

First. Send them out from the ship, one at a time, by means of a lighter, steam-tug, or boats (the latter method will be given hereafter), and let go in the proper positions. When both are so planted, clap deck tackles on the cables, get them suitably taut, and secure.

Second. Having the work half accomplished, as before described, put a good buoy and buoy-rope on both chains (port bower and starboard sheet), unshackle inboard, slip them both, and haul over by kedge or otherwise to the berth of the starboard bower, let it go, and haul over to the berth of the port quarter anchor, let it go, bring to on the starboard bower, and heave in to the proper scope-or, in other words, repeat with the remaining two anchors, the first half of the operation. The ship being now in her central berth, she may, by means of the buoy-ropes, pick up her port bower and starboard sheet, and heave all taut to liking.

HAVING MOORED HEAD AND STERN-TO UNMOOR SHIP.

If the stern moorings are made fast to the shore, simply cast off the ends, clap on deck-tackles, and walk them inboard.

If moored with anchors astern, to unmoor, proceed in the following manner:

Let us suppose that we are moored with the two bower anchors ahead, and the two sheet anchors astern. Pass a good hawser out of the sheet hawse-hole, on each side;

275

take the ends aft, outside of everything, and bend them to the stern cables at the nearest shackles. Have all clear for veering the bowers; unbitt them, and set mizzen topsail (aback), if the wind is light and ahead; stopper the stern cables, unshackle them at the nearest shackle inside the stern-port or pipe, and be ready to slip. Veer away the bower chains roundly, slip the after cables, man the hawsers, and walk the stern cables in through the sheet hawse-holes. Veer away the bowers, clap deck-tackles on the sheet cables, and heave them in. When near the berth of the starboard sheet anchor, slack the port sheet cable, and heave the starboard sheet up and down, with the deck-tackle. Stopper the bower cables, bring to on the starboard sheet, and heave it up with the capstan. Cat it, and then heave up the port sheet in the same way. Cat it, and bring to on the lee bower; put the deck-tackle on the weather one; heave round and walk away. When the lee anchor is up and down, avast heaving, stopper the weather cable, and send all hands on deck to assist in transporting the sheet anchors to their places; when that is done, heave up the lee anchor, cat and fish it; heave in, or veer away, to the required scope on the weather cable, and pipe down.

If, when mooring, it was found necessary to drop one (or both) anchors in water too shoal to float the ship, send the launch out to weigh it. Bring to on the cable, and when the launch has lifted the anchor clear of the bottom, heave round slowly, and bring the launch near the bows; she will then slip the anchor, and it will be hove up.

TO KEEP THE HAWSE CLEAR OR TEND SHIP WHEN MOORED-(TWO BOWERS).

When a ship is moored the sails are generally unbent, with the exception of the jib and spanker. With these two sails, the helm, and a knowledge of the principles of tending ship, an officer can scarcely go amiss. If the stern of the ship must go to starboard to keep the hawse clear, put the helm to starboard at the last of the old tide, and to port at the beginning of the new. This will have the effect of sending the stern to starboard and making her swing as desired. Use the spanker if it can be made effective.

A little attention in this matter on the part of the officer of the deck may save a great deal of work in

clearing hawse. Should it be required to swing against the wind, use the jib.

CLEARING HAWSE.

A vessel moored, and riding by either anchor, having

276

the cables clear of each other, "*rides with a clear hawse.*" If her head is in a line between the two anchors, so that the cables will each lead out from their respective sides, and clear of the stem, she then "*rides to an open hawse.*"

If, by swinging, she brings the cables to bear upon each other, so as to be chafed by the motion of the vessel, she has "*a foul hawse.*"

If, from having an open hawse, she has swung half round, or performed a half circle, she brings "*a cross in the hawse,*" and that cable will be uppermost from which she swung. If it is the starboard cable which is uppermost, she must swing to starboard, if the port, to port, to clear the hawse.

But if she swings the wrong way, that is, continues the same way she swung before, performing another half circle, then there will be "*an elbow in the hawse,*" the same cable being uppermost. We will suppose that in both instances she has swung to port, then the starboard cable is of course over the port one, and she must swing to starboard to bring the hawse clear. Thus, from an *open hawse* she has performed a full circle to produce an *elbow*.

The next half circle in the same direction brings "*a round turn*" in the hawse.

And the next half circle, "*a round turn and elbow,*" and so on.

An attentive officer will always endeavor to make his vessel, having a cross in the hawse, swing so as to clear it, by means of the helm or otherwise. But if she swings the wrong way, he should lose no time in resorting to the operation of clearing hawse by the cables.

To Clear Hawse. Get up the clear-hawse gear. This consists of deck-tackles, hook-ropes, the clear-hawse pendant and the hawse-rope.

Deep-Tackles are heavy double purchases, with a hook in each block.

Hook Ropes are single ropes, with a hook in one end, and are used in lighting along the chain, in connection with long-handled *chain-hooks*. Fig. 459.

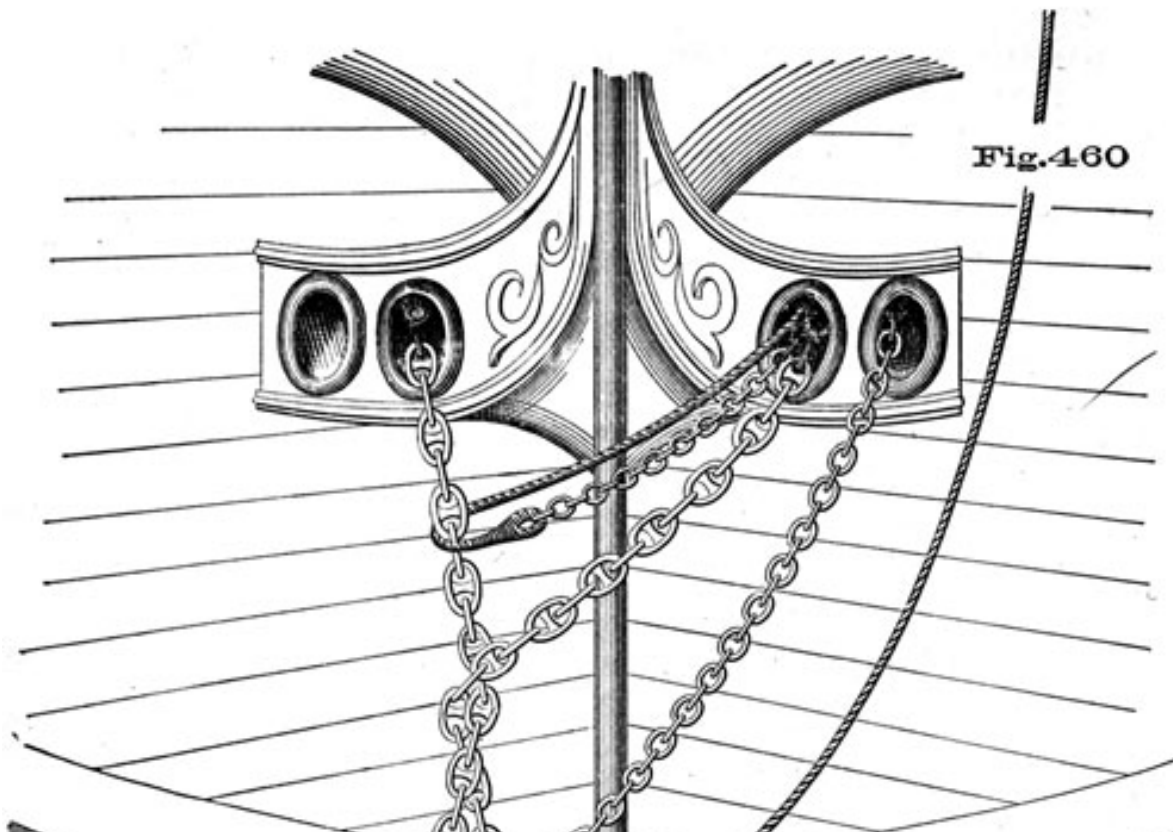
The Clear-Hawse Pendant is a heavy hemp rope, tailed with chain and having a shackle, or (better) a pelican hook in the chain end.

The Hawse-Rope is a stout hemp rope tailed with chain, with sister-hooks in the chain end.

If the turns are under water they must first be hove out clear. This is usually done by clapping a deck-tackle on the riding, cable, forward of the bitts, hauling in and stoppering the riding chain forward; light the slack around the bitts and pass the after stoppers afresh.

Pass the clear-hawse pendant out of the sheet hawse-hole on the side of the lee cable, shackle it to that cable below the turns, house it taut with a deck-tackle and belay it.

Plate 102



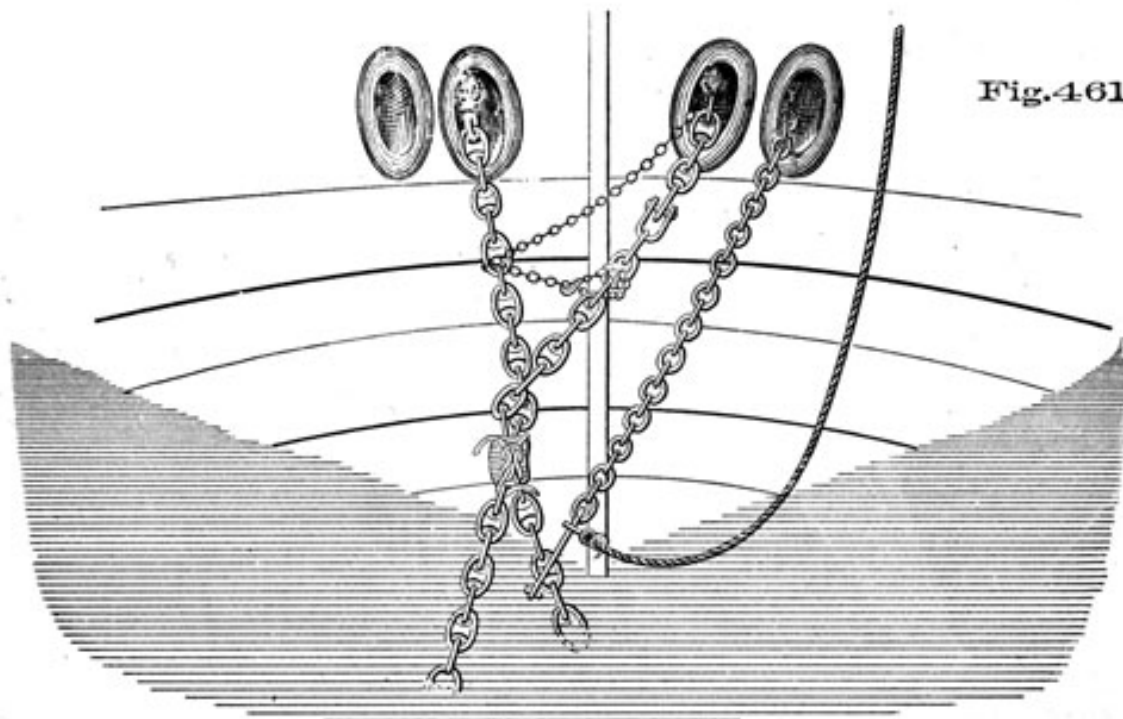
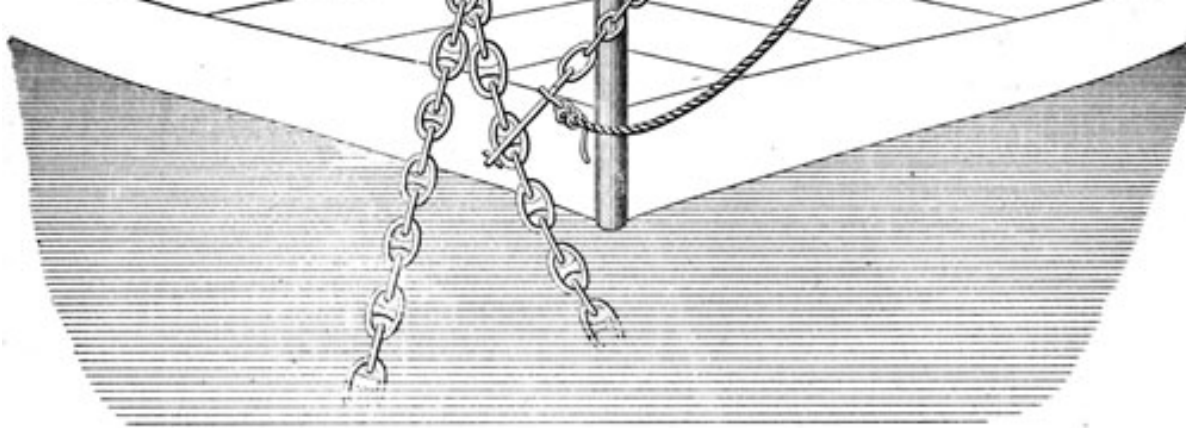


Fig. 461

Now pass the end of the hawse-rope out through the lee hawse-hole, take it around the riding cable in the direction opposite to the turn in the hawse, pass the end in again, Fig. 460, and hook it to the lee cable forward of the shackle. Now unshackle the lee cable, haul away on the hawse-rope and light out the lee cable, using a line from the bowsprit if necessary to assist in hauling it out.

When the hawse-rope brings in the end of the cable again, secure the cable end temporarily if need be, and repeat the operation with the hawse-rope from the beginning, if there are more turns to be taken out.

When the lee cable comes in clear, clap on a deck-tackle, walk away and shackle, unhooking the hawse-rope.

Take off finally the clear-hawse pendant, and dry and stow away the clear-hawse gear.

When the clear-hawse pendant is fitted with a pelican hook it can be readily cleared from the chain, even if it gets under water, by a laniard from the upper part of the link.

In small vessels, or with light ground-tackle, the above plan may be slightly modified, to advantage, especially when the hawse-pipes are narrow. Fig. 461.

The turns being hove above water, clap on the clear-hawse pendant as before. It is advisable also to clap a lashing on the two cables below the turns, if the moorings are slack, to keep the turns from sliding down under water again on the riding chain. Now, instead of using the hawse-rope, pay out the nearest shackle of the lee cable into a boat under the bows, unshackle there and use a hook-rope to clear the turns, having the hauling end inboard. When the turns are clear, hook the hawse-rope into the end of the lee chain to rouse it inboard through the hawse-pipe. Shackle, cast off the lashings on the chains, and take off the clear-hawse pendant.

One object is not to have so many parts (two of hawse-rope and one of chain) in the hawse-hole at once. Moreover, when the use of the boat and hook-rope is practicable, the hook-rope can be more readily shifted and the operation performed quicker.

When veering out the end of the lee cable have a good turn with the hawse-rope, so that in case the clear-hawse pendant parts, the hawse-rope may hold the weight of the chain.

Never clear by the riding cable, nor at any other time than at slack water if it can be avoided.

A screw steamship, with steam up, can turn round with her screw and helm, and clear hawse in a short time. But the steam would not be up unless she was about to sail; and in that case she should clear hawse,

unmoor, and heave in to a short scope while raising steam.

The hawse is *sometimes* cleared, when there is no wind and a smooth surface, by *towing* the stern of the ship round

in the required direction. A *long* ship should never attempt it, and it is not a very seamanlike way of clearing hawse at any time.

In weighing, if there is a cross in the hawse, the undermost cable should be hove in first; the upper anchor, if hove up first, would foul the under cable.

If it is necessary to pick up the upper one first, dip it before weighing.

In unmooring, heave up the lee anchor first to avoid the chance of fouling other ships or your own anchor.

TO PUT THE MOORING SWIVEL ON. Fig. 462.

By putting the mooring swivel on, the hawse is more easily kept clear.

The best time to put it on is at slack water, or as near it as possible. To do so, shackle the clear-hawse pendant to the lee cable, as in clearing hawse, and haul it taut. Send a boat under the bows with the swivel. Make fast a bowline from the bowsprit end, rouse out chain and pay the shackle into the boat; the men in the boat unshackle the chain and shackle it to the swivel.

Now put the clear-hawse pendant on the riding cable, haul it well taut, unshackle the riding cable, veer it into the boat, and shackle it there to the swivel as we did the lee one.

If there is any doubt about the clear-hawse pendant being strong enough, we must use a large hawser, or the stream chain, to secure the riding cable, or postpone putting the swivel on the riding cable until the ship has swung.

When the swivel is on, it must be hove up clear of the water.

It is usually hove up close to one hawse-hole, and the other chain is then overhauled clear of the bows, or unshackled altogether. After the swivel is on, the two chains from inboard constitute what is called the

bridle.

Finally, take off the clear-hawse pendant.

The swivel should be put on with the *cup* upward that it may be more effectually lubricated.

If the swivel is so small that we can pass it through the hawse-hole, it can be put on with much less trouble. We have only to stopper the riding cable inboard, unshackle, put the swivel on and veer it outboard. Then send a boat under the bows and put it on the lee cable as just described.

Many seamen object to the use of mooring swivels under any circumstances. They should certainly not be used when bad weather is liable to make veering necessary.

Plate 103

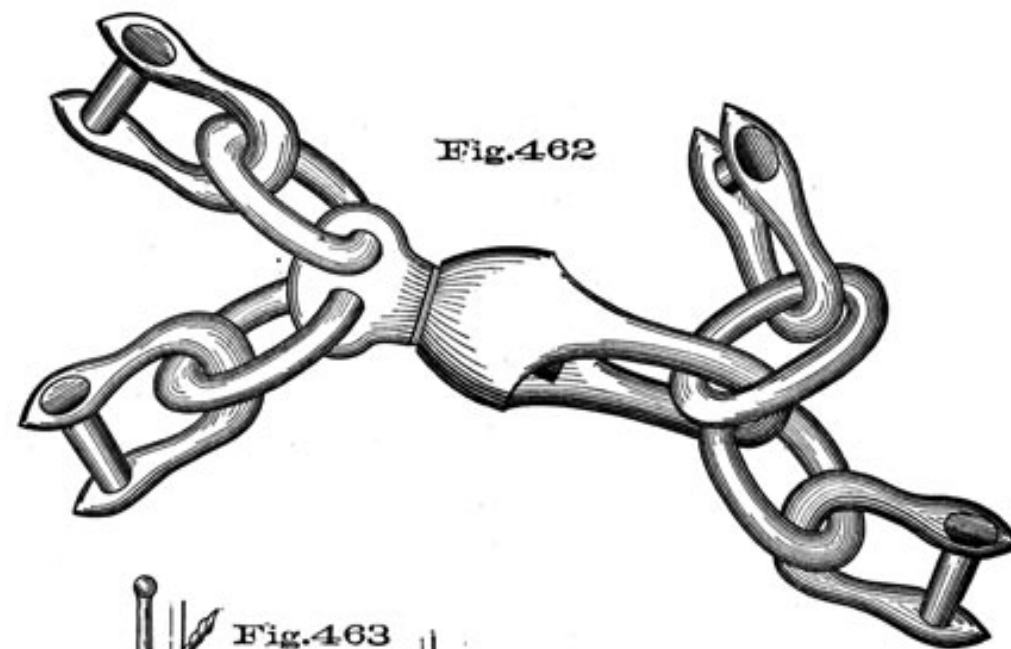


Fig. 462

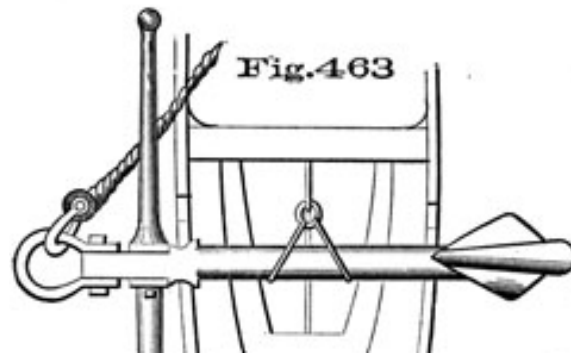


Fig. 463

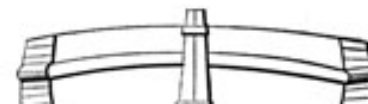


Fig. 466

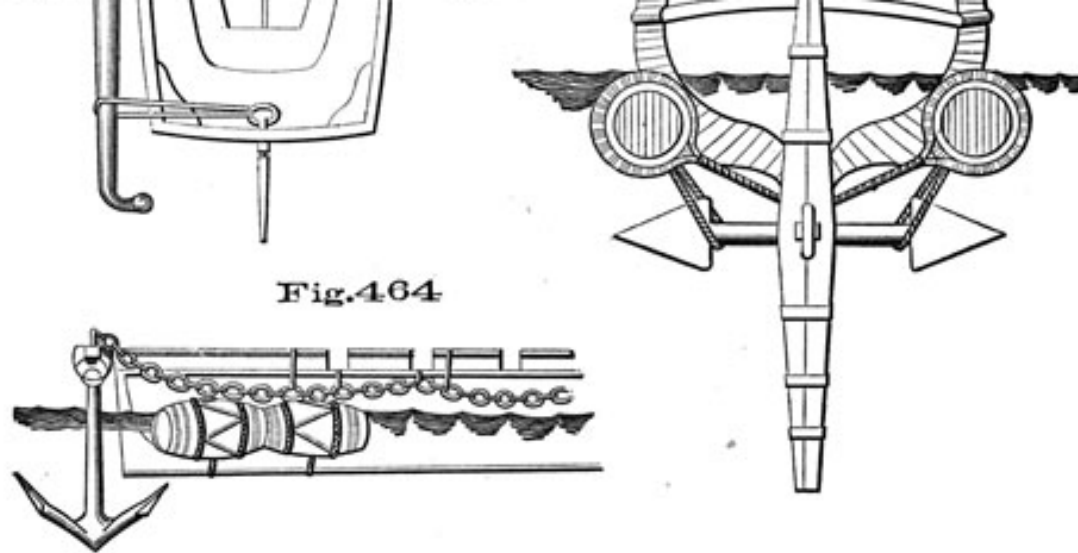


Fig. 464

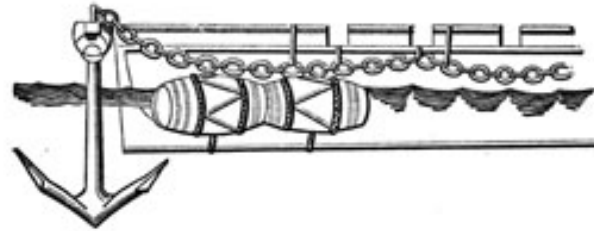
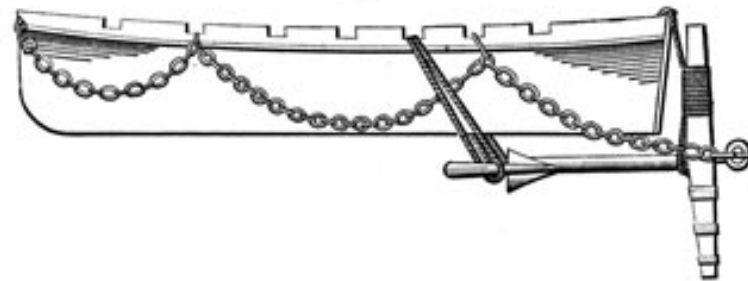


Fig. 465



CHAPTER XVII.

CARRYING OUT ANCHORS BY BOATS.

To Carry out a Kedge or Stream Anchor by a Boat. Hoist the kedge out by the yard and stay, and lower it into the water astern of the boat. The coxswain hangs it there by a piece of three-inch stuff. One end of this is secured to the ring-bolt in the stern, the other end, passed around the shank just under the stock, is belayed for slipping. Settle down the yard tackle and unhook. Bend the hawser and coil it away in the boat. When the kedge is to be let go, heave the remainder of the hawser overboard and slip the stopper.

A small kedge may be made much more effective by lashing pig ballast or other convenient weight to it.

Circumstances will determine whether it is better to take the entire hawser in the boat, drop the kedge and bring the end back, or to pay and go from the ship, as assumed above.

To Carry out a Kedge or Stream Anchor in a Boat. Fig. 463. Hoist it out by the ring; when the crown is below the gunwale, hang it with a rope from the bottom bolt around the arms, and as it is lowered, bear the stock over the opposite gunwale, and bend the cable on under the stock after you have rolled the anchor aft. In this way you can steer and pull the after oars. To let go, unship the rudder, get enough chain out of the boat to reach the bottom, and roll the anchor overboard over the stern.

With a short anchor, place the midship thwart across the stern, lay two capstan bars fore and aft, and land the anchor on this platform fore and aft, with the flukes over the stern, stock on the capstan bars.

Steer in this case with an oar. To let go, raise the inboard ends of the capstan bars simultaneously.

Neither of these methods of carrying an anchor in a boat should be attempted, except by experienced hands.

If both ends of the shank, in the first case, do not roll over the stern simultaneously, or if the capstan bars, in the second case, are not lifted together, there is likely to be trouble.

For transportation *only*, the method is a good one, with light anchors.

CARRYING OUT A HEAVY ANCHOR WITH ONE BOAT.

First Method. (*The quickest way.*) Sling empty casks or beef barrels in pairs, marrying their slings and snaking them to prevent them from being shaken off. Bung the casks well and lower them overboard.

Out launch, lower it so that the stern will be supported by the casks, lash these securely to the boat, two on each quarter.

Haul the launch forward with a boat rope from the jib-boom end, steady her if necessary by a whip from the fore-yard braced forward.

Cockbill the anchor and lower it with the stock hanging horizontally across the stern of the launch. Take a stout strap around the shank, reeve one bight through the other, and jam the turn close up under the stock,

take the other bight through the stern ring-bolts, and toggle it. In letting go, out toggle, or cut the strap.

With a large launch prepared as above, a good sized_ anchor and cable can be carried out. Fig. 464, Plate 103.

Second Method. *Anchor too heavy to hang from launch's stern.* In this case, the flukes must be hove up under the bottom of the boat, the stock being perpendicular. Fig. 466.

Out launch, increase her buoyancy aft as before. Rig the fish-davit. Seize two large thimbles into two straps, which are clapped around the arms of the anchor just inside the flukes, a piece of a stout towline is rove through the thimbles, the tow-line being stopped to the shank to keep it middled. Put a long pair of slings around the shank near the stock, and lash them to its upper end to keep the stock perpendicular. Round the shank also, and stopped to the stock is the end of a stout rope, to be used in securing the ring. Hook the fish to the inner arm from aft forward, hook the cat to the stock slings and ease the anchor down, keeping the shank horizontal and the stock perpendicular until it is about four feet under water; bring the launch's stern against the stock; haul her side in close to the fish; secure the stock end of the anchor to the stern by the end of rope provided for the purpose, passing the turns through the stern ring-bolts; bring the ends of the towline stuff in on each side through the rowlocks, and secure them through the foremost ring-bolts; ease up and unhook cat and fish; stop a length of chain round the boat outside, and then range as much more chain in the bottom as is intended to be carried out, stopping it in several places, and making the end well fast that it may not fetch away in veering. Fig. 466.

To let go, cut or slip the stock and fluke fastenings together.

Fig.467

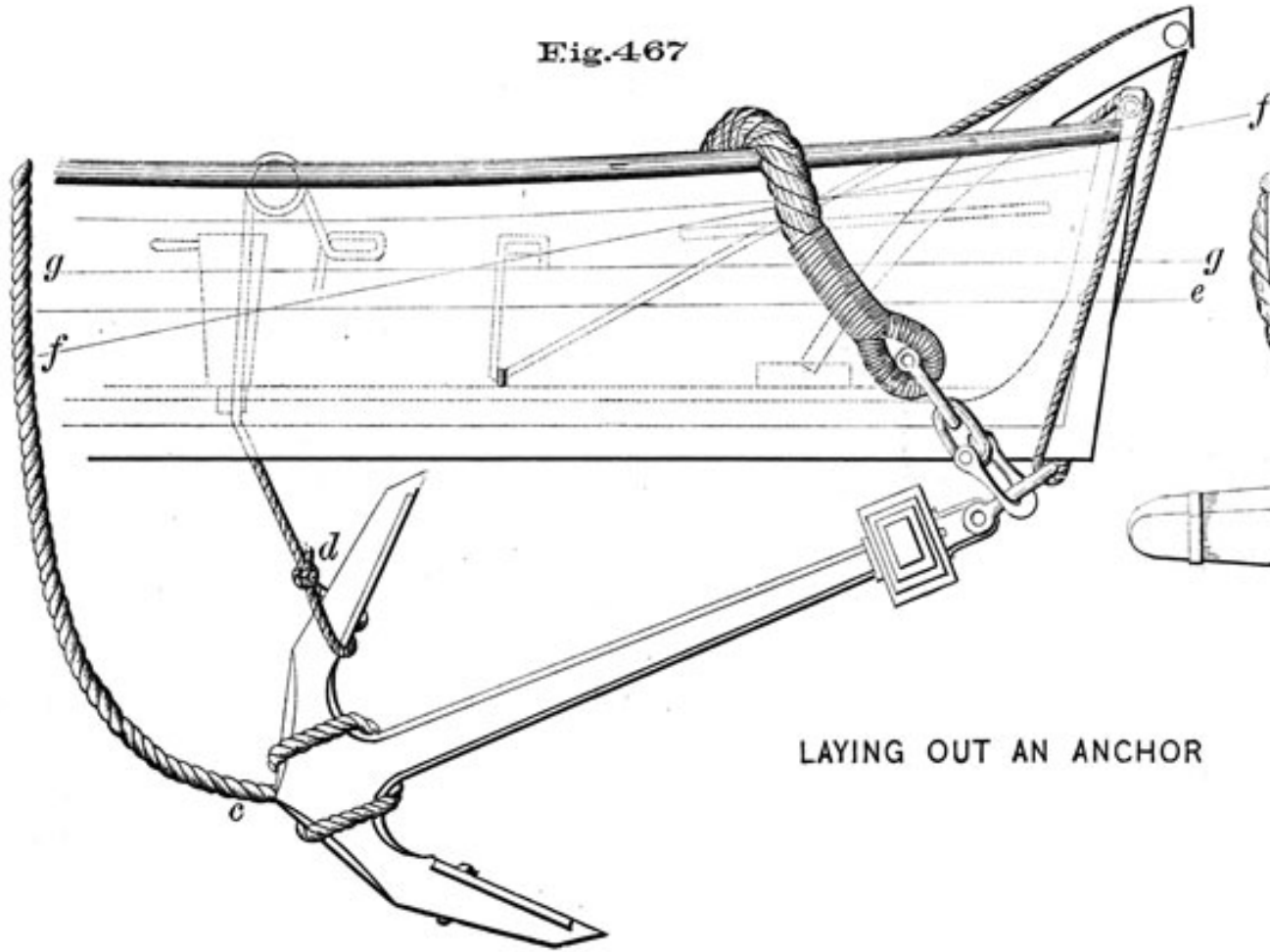
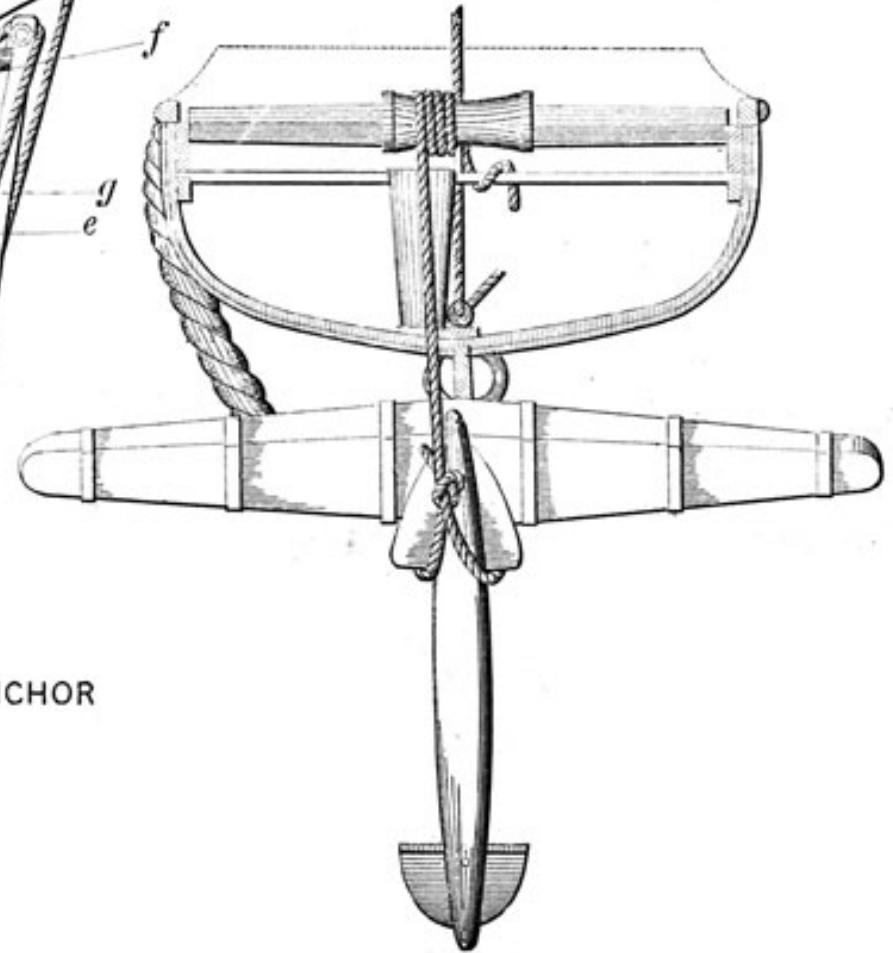


Fig.468



LAYING OUT AN ANCHOR

In either of the above methods the casks are of course dispensed with if unnecessary (Fig. 465); but with the relative sizes of launches and ground-tackle supplied to our ships of war, it is most likely that the additional buoyancy will be needed.

A boat will tow more easily by the first method than with the anchor entirely under her bottom.

Third Method. (*Stock horizontal, flukes perpendicular.*) This plan was first suggested by a Mr. Cows, of England. The object is to bring the weight of the anchor on that part of the boat most capable of bearing it, and to use a purchase in the boat equal to heaving up any weight she can sustain.

This is done in suspending the anchor by a rope passing through a hole in the bottom of the launch, a tube placed over the hole preventing the water from filling the boat.

Launches are fitted with such a hole, covered by a brass screw-tap, outside of which screws a copper funnel. When preparing for use, screw on the funnel, or *trunk* as it is sometimes called, unscrew the tap; as soon as the latter is off, the water rises in the trunk till level with the water outside.

Immediately over the trunk, Fig. 468, is placed a windlass, the pins in its ends working in bearings on the gunwale.

Haul the launch forward, cock-bill the anchor; secure to its forward arm the end of the windlass-rope.

To get the other end of the windlass rope through the trunk, drop a lead and line through first, hook the lead-line from outside with a boat-hook, and haul through, marrying the lead-line to the end of the windlass-rope.

Lower the anchor by the cat, with the stock athwart the stern of the launch, man the windlass, and heave the flukes under the boat, keeping the boat clear of the shank. When the anchor is lowered have the usual stopper rove through the ring and taken over the stern roller of the launch. When the stock is close up under the boat secure the stopper through the after ring-bolts, with turns around its own part and around the after-thwart.

Fig. 467 represents a first-rate's launch, with a bower anchor suspended under the bottom, and a hemp cable coiled away in the boat; *c* is the buoy-rope; *d* the rope by which the anchor is hove up; *e* the line of flotation when the vessel is light; *f* the line flotation with bower anchor hung in the ordinary way to the stern; *g* the line of flotation with anchor hung as represented, a cable and twenty men in the boat.

When a ship is on shore forward, unless Cows' method is used it may be impossible to carry out a large

TO HAUL OUT A BOAT ENGAGED IN CARRYING A BOWER.

If the steam launch is not available for towing, send out first the stream anchor hung at the stern of the launch, the casks being omitted if the weight is not too great for the boat. Take the stream out in the direction in which the bower is to be planted, and beyond the intended position of the bower. Have a stopper long enough to lower the anchor to the bottom, and a top-block, large enough to take a hawser, hooked in the ring. Lower the anchor to the bottom, the hawser being rove through the top-block, and bring both ends back to the ship, being careful to keep them clear.

Secure one end of the hawser in the bows of the boat which is to be hauled out, and pass the other end in the hawse-hole.

A kedge planted well ahead of the position which the bower is to take, with a single warp led back to the launch and hauled upon there, may be used instead of a double line, as above described.

Weigh the warping anchor or kedge, when the operation of hauling out is completed.

TO CARRY OUT AN ANCHOR BY TWO BOATS.

This may become necessary owing either to the shallowness of the water, or to the lightness of the boats available for transporting the anchor.

First Method. *To sling an anchor between two launches in shallow water.* (Fig. 469.)-Hook the cat and fish; the cat to the ring and the fish to a strap round the crown. Put a short strap round the crown, one bight being rove through the other, and a thimble seized in for hanging the anchor by. Haul taut the cat and fish, let go the anchor stoppers, and lower the anchor down nearly to the water's edge. The boats haul up, each having a good stopper for hanging the anchor. The headmost boat secures the stopper to the ring-bolt in the bottom of the boat, passes it over the stern roller, through the ring of the anchor, over the roller in the end of the stern davits, and secures the end to a luff tackle, which is hooked to the bow ring-bolt. Bowse the tackle well taut and secure; ease up and unhook the cat.

The second boat hauls up bow first, secures her stopper to the ring-bolt in the bottom of the boat, passes it over the bow through the thimble in the strap on the crown, in again over the bow, and secures the end to

a luff hooked to the after stern ring-bolt.

Plate 105

LAYING OUT AN ANCHOR IN SHALLOW WATER

Fig. 469

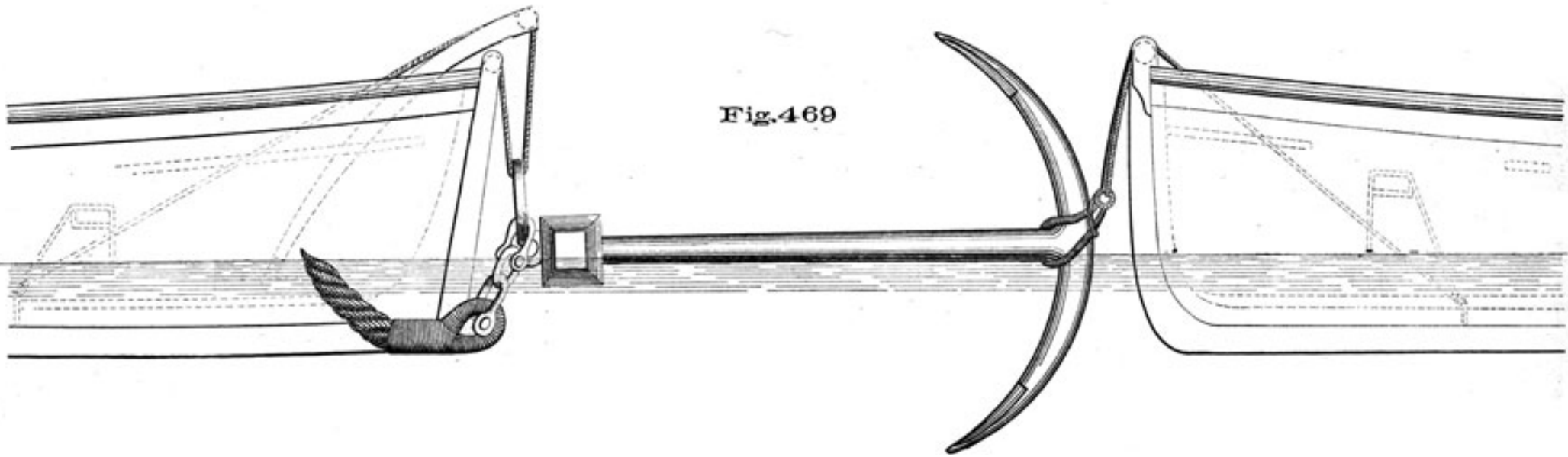


Fig.471

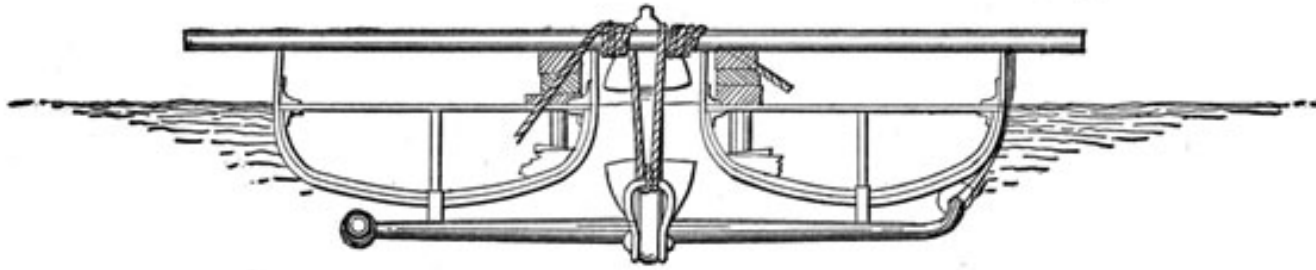
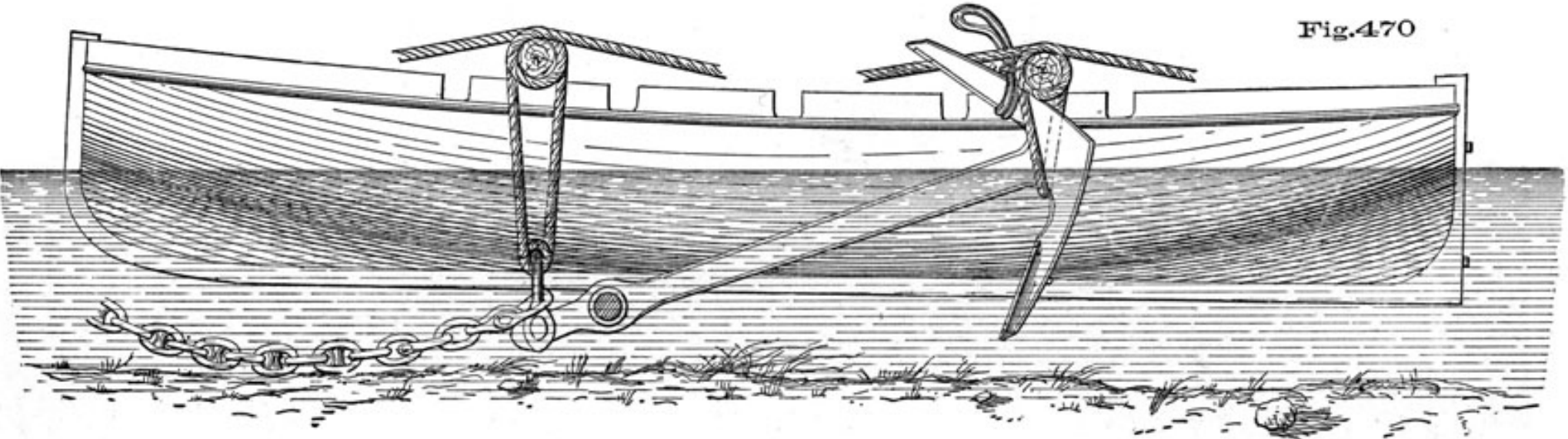


Fig.470



Bowse taut the luff, secure, and ease up the fish,

To Let Go. Ease the anchor down clear of the boats with the luff tackles, then slip the ends of the stoppers together.

Unless fitted with chain slips, there is danger of one stopper slipping before the other; therefore, warn the men in both boats to be careful.

Each boat will carry out a considerable quantity of the cable in the opposite end.

Second Method. *Carrying out a bower between two cutters.* (Plate 106). The stream having been previously sent out and planted, with the top-block at the ring, hawser rove off, &c., prepare to send out the bower between two cutters, as follows:

Hook the cat to the ring, the fish to a strap around the inner arm of the anchor, ease off the stoppers and lower the anchor into the water, stock athwartships, flukes up and down. Haul up two cutters, one on each side of the purchases. Lash two suitable spars across the boats, one a little forward of the centre of gravity, the other further aft at a distance nearly equal to the length of the shank. The spars rest on the gunwales of both boats, building up if necessary in wake of the inner gunwales to strengthen them.

Clap on the cat and pull up till the stock takes under the keels of the boats. Secure the ring to the forward spar by a lashing long enough to lower the anchor to the bottom on the bight, taking two round turns through the ring and around the spar, and expending the ends *in opposite directions* around the spar.

Now clap on the fish and pull up till the upper pee is nearly level with the after spar. Secure the fluke to the after spar by a lashing similar to the ring lashing, and passed under the shank. The strap for the fish will probably be jammed between the lashing and the upper fluke (hence the reason for using a strap instead of hooking the fish itself to the inner arm), but by bending a small line to the strap it can be recovered after the anchor has been eased down. Clap rackings on the lashing and knot the ends together above each spar until ready for easing away.

Fit a span across the sterns of both boats, and to it secure the end of the hawser used in hauling out.

Lastly, ease off and unhook the cat and fish. The anchor now hangs between the two boats, which are only separated by a distance a little greater than the width of the anchor fluke.

The bower cable, shackled to the anchor, is unshackled at fifteen fathoms and the end carried in another boat, which tows out in rear of the first two.

When ready to let go, the rear boat being close up, ease

away together on the ends of the lashings, and lower the anchor to the bottom.

Half the turns of the lashing on each spar being taken in one direction and half in the opposite way, the spars have no tendency to roll out of position, and any undue strain on their lashings is avoided.

Cast adrift the spars and send back one boat with the standing part of the hawser. Let her take the end of the chain in her bows with end enough to shackle, hang the bight to her stern and haul out again by the hawser from on board. When the chain begins to drag, the second boat is brought under the bows and a bight hung to her bow and stern in the same manner. On reaching the boat supporting the end of the first fifteen fathoms, the leading cutter receives that end, shackles, and both cutters slip the bights at the same time.

If the state of the sea does not admit of towing out the cutters stern first, we must forego the advantage of supporting the greatest weight of the anchor by the sterns, and haul the boats alongside the purchases, bows aft.

The above method, as described, was adopted recently in laying out anchors at the Training Station. Based upon the plan adopted by Captain Craven in the "Plymouth," it differs from the latter in the following respects: The anchor in Captain Craven's method hangs with the stock up and down, and the flukes athwartships, and under the bows of the boats; boats are further apart, and the anchor is cut adrift instead of being lowered. The cable in the "Plymouth's" evolution had the end buoyed, and was towed out in the wake of the cutters.

By the modified plan it was intended to have the anchor draw less water, and to bring more strain on the boats and less on the spars. Lowering the anchor instead of cutting it adrift, enables the end of the chain to be carried out in a boat instead of buoying it, which is believed to save time in the shackling, while the tow is lightened.

The lashings used in lowering the anchor were 5 1/2-inch rope, the depth of water four fathoms, weight of the anchor 5,500 pounds.

To carry out a heavy anchor and chain is considered a somewhat difficult as well as a dangerous operation. In 1842 a lieutenant and several men lost their lives while attempting it in a launch belonging to the U.S.S. Missouri, then aground in the Potomac River. This accident was due to the chain being stowed in the boat.

A long range of chain should never be carried in the boat with the anchor. Even when small anchors and hawsers

285

are being carried out, heave overboard enough of the hawser and plenty to spare *before letting go the anchor*, to allow it to reach the bottom. If not, the anchor on being let go, will take the boat with it. A bight of chain is usually stopped around the boat ready for dropping, and if this is not enough, more must be paid out. Put check-stoppers on the chain while it is being stowed in the boat, securing them to a thwart or ring-bolt; this will decrease the danger of the cable's taking charge when paid out.

When about to let go the anchor, make sure by a cast of the lead that you have cable enough outside the boat to reach the bottom, and hang it well to the stern that no more may run out. If there be a greater quantity of chain in the boat than can be ranged in one layer, there will be damage done unless you disconnect at the first shackle and bring it to the last one, which will be the upper one of the range paid down.

Let go the anchor with the ring toward the vessel.

In veering chain, lash a capstan bar athwart the stern; lay the cable over it and veer away cautiously fathom by fathom. If the end of another cable is brought to you, join it; hang the joining shackle outside your boat, and throw the bight out, letting both parts hang from the stern *over* the bar—that is to say, have no cable now remaining in the boat, and when all is clear, slip the bight.

This proceeding will suggest the necessity of always taking punches, shackle-pins, and hammers in a boat, when setting out on an anchor expedition.

After letting go an anchor, if the cable remaining in the boat gets away from you, direct the men to jump overboard and hang on to the gunwale till the cable is out.

When using a buoy on a bower that is laid out, stop the buoy-rope to one pee of the anchor and stopper it short of the depth of water; this insures canting the anchor for biting.

Warping out *against* wind and sea, lay out the cable on your return if *before* it, pay as you go.

When likely to weigh a stream or heavier anchor by boat, put a block on the crown and reeve a double buoy-rope through it.

In lowering a *waist* anchor by the tackles to be carried out, hook the main yard-tackle on the inner arm, and the fore yard-tackle in the ring to ease it down with the stock athwartships. A bill-tackle on the inner arm will keep the anchor from canting too quickly.

Sweeping for Anchors or Cables. Having lost an anchor and chain, attempt first to catch the chain; failing in that, the anchor itself. The position of the anchor is known by the cross-bearings taken when the ship anchored, also the direction of the chain.

286

First: To catch the chain. Send out boats to pull at right angles to its direction, each dragging a grapnel after her.

In addition to ordinary grapnels, use for this purpose two fish-hooks (hooks used in fishing the anchor), joined at the eyes and kept apart with their hooks in the same direction by a few small battens lashed across their backs. This is dragged by the eyes, the bills of the hooks are kept down with a back-rope, which should always be used in grappling, to clear rocks and other obstructions.

When the chain is grappled, send out the launch and weigh it; hang the bight and drop the creeper down again, and so work till the end is reached, carry this to the ship, heave in, and heave up the anchor.

Second: To sweep for the anchor. Weight the bight of a line for some distance each side the middle, and putting an end in each of two boats, let them pull across the position of the anchor. A small chain is the best to sweep with.

The boats must be well apart, and the line dragging on the bottom. Sweep in the direction from ring to crown.

When the anchor is caught, cross the boats and haul up over it; drop the bight of a hawser down over the line so as to catch over the upper flukes, slip an anchor shackle down over both parts to confine it, warp the ship up, take one end of the hawser to the capstan, clap a deck-tackle on the other and weigh the

anchor.

A running bowline may be slipped over the upper fluke.

To Weigh a Bower by a Launch Pitted with a Trunk. Having caught the upper fluke as described above, pass the ends of the hawser through the trunk, bring to on the windlass and heave up.

The crown being up, pass the end of the after-stopper from one quarter around the bow and aft the other side, let go the bight forward, and it will catch the shank of the anchor, hook on the luffs, and heave up the stock; catch the chain in the same way and heave it up to another boat.

The boat might be warped alongside as soon as the crown is up; then sweep a strap under its bottom, crossing the parts with a round turn around the shank of the anchor. Hook the fish tackle in the ends, walk up the anchor crown first until the ring is high enough to hook the cat.

To get the anchor up, *ring* first, sweep the steam cable under the boat (*so as to catch between the stock and flukes*), form a running clinch with the end around the other part, heave in on the stream, ease off the hawser, haul the boat clear, hook the cat when the ring is high enough. Should a portion of the cable be attached to the anchor, sweep under. it, take the end through the hawse-hole and heave in.

Use the buoy-rope instead of the hawser in heaving up, if it is strong enough.

A Jury Windlass, in a launch, may be rigged by having a round spar secured athwart the boat, and working it with straps and heavers, having the hawser, buoy-rope or cable, led over a roller at the stern.

TO WEIGH THE STREAM ANCHOR BY THE LAUNCH.

Ship the davit or roller in the stern, pass in the boat a. couple of good luffs, straps, spun-yarn, and stuff for stoppers. Bring the cable over the roller, and clap on a luff, single block to ring-bolt in the bows. Clap luff upon tuff if necessary to break ground. If the anchor holds hard, heave to a short stay, getting the stern well down, and belay; then let all hands go forward and try to jump the anchor out. When aweigh, clap the luffs on alternately, faking the cable in the boat.

When the anchor is up, hang it to the stern of the boat and pull on board.

TO CALCULATE FLOATING POWERS.

In using casks, tanks or spars for carrying out anchors or other heavy weights, the floating powers may be estimated by the following rules:

To Calculate the Capacity of a Cask. Multiply half the sum of the areas of the two interior circles (viz.: at the head and bung), by the interior length, for the contents in cubic inches; dividing the product by 231, the number of cubic inches in a gallon, reduces the result to that measure.

To find the Number of Casks required to give a certain Floating Power. Multiply the cubic capacity in gallons by 8.4, the weight of a gallon of water; the result gives the floating capacity in pounds. The weight of the cask need not be considered.

To Calculate the Floating Power of Spars, for the Same Purpose. Say the three topmasts; the main being sixty-four feet long (exclusive of mast-head), diam. 22 in.; fore, 57 ft., diam. 22 in.; mizzen, 45 1/2 ft., diam. 17 in. The weight that they will sustain, is the difference between their own weight and that of the water they displace.

To ascertain the weight of a spar: Multiply the square of the diameter by .7854 (the area of a circle whose diameter is one inch), to find the area; multiply the area by the length, to obtain the cubic contents; and the product by the weight of a cubic foot of the material, ascertained by experiment.

288

Main topmast.-The greatest diameter being twenty-two inches, the proportion of diameter at first quarter is 60/61; second quarter, 20/21; third quarter, 8/9; equal to 22 in., 21.6 in., 20.9 in., and 19.5 in., respectively; consequently twenty-one inches is the mean diameter.

64 ft. = 768 in., and $21^2 \times .7854 \times 768 / 1728$ (the number of cubic inches in a foot) = 154 cubic feet.

Fore topmast.-57 ft., in like manner gives 137 cubic feet; and

Mizzen topmast.-45.5 ft., with a mean diameter of 16.2 in., is equal to 65 cubic feet.

Total 356 cubic feet.

356 x 64.1 (the weight in lbs. of 1 cubic foot of salt water) = 22819 lbs.

356 x 36.3 (the weight in lbs. of 1 cubic foot of Norway spars) = 12923 lbs.

Floating power of spars 9896=88 cwt.

DECREASE IN WEIGHT OF IMMERSED BODIES.

If these calculations are made with a view to carrying out an anchor, &c., it must be remembered that the weight of that anchor, *in water*, is less than when it is out of water, by the weight of water it displaces. The specific gravity of wrought iron is 7.788, and of salt water 1.026, therefore the specific gravity of iron in relation to salt water is $7.788/1.026 = 7.59$.

The "Trenton's" bower weighs 7,000 pounds. Divided by 7.59, gives a decrease in weight when the anchor is submerged of 922 pounds.

Or the decrease of weight consequent on immersion of a body may be found by calculating its cubic contents, and then ascertaining the weight of its equivalent bulk of water.

7,000 pounds = 112,000 oz., which divided by 7788 (specific gravity of iron), gives a quotient of 14.367 nearly, being the cubic contents of the anchor in feet. A cubic foot of salt water weighs 64.2 pounds; therefore 14.367 cubic feet weigh 922 pounds; decrease of weight being same as by previous rule.

 [Previous Part](#)  [Seamanship](#)
[Home Page](#)  [Next Part](#)

Copyright (C) 2006 [Historic Naval Ships Association](#)

All Rights Reserved

[Legal Notices and Privacy Policy](#)

Version 1.00, 24 Apr 06

ORGANIZATION.

WHEN a ship goes into commission the proper and early organization of officers and crew calls for the earnest attention of the *executive* officer upon whom the duty chiefly devolves.

The duties of officers on board ship are defined by the regulations, and are known to most of them by actual experience at sea, and the special duties of midshipmen will be dwelt upon in detail further on. But the men supplied for the crew are many of them foreigners, or merchant sailors, unaccustomed to the routine of a man-of-war, or others totally ignorant of ship-life. These form a motley crowd which must be sorted out, and the work of the ship so distributed among them that, each one carrying out his part, the daily routine may be efficiently and promptly performed. The organization and routine, together with the drills and exercises which form their principal feature, all have for their ultimate object the preparation of the ship for battle.

That the machinery of a man-of-war, when once put in motion, may work properly, it should be perfected at the outset. A little well-directed industry *then* will save much subsequent confusion.

The number of men allowed to each vessel of the navy, exclusive of the engineer's force, is based upon the number and calibre of the guns composing her battery.

Tables for ascertaining the complement of any vessel in the service will be found in the Equipment Book of Allowances.

The following petty officers are commonly known as "appointed" petty officers, viz.:

The Master-at-Arms,
Ship's Yeoman,
Engineer's Yeoman,
Apothecary,
Pay Yeoman,

but the terms apply strictly only to the last named.

The petty officers are divided into two classes: *petty officers of the line*, and *petty officers*.

The *petty officers of the line*, in order of rank, are as follows:

Boatswain's Mates,
Gunner's Mates,
Signal Quartermaster,
Coxswain to Commander in Chief,
Captains of Forecastle,
Quartermasters,
Quarter Gunners,
Coxswains,
Captains of Main-top,
Captains of Fore-top,
Captains of Mizzen-top,
Captains of Afterguard.

All other petty officers, except the Master-at-Arms, who is chief petty officer of the ship, take precedence as follows:

Ship's Yeoman,
Machinists (1st class),
Engineer's Yeoman,
Apothecary,
Paymaster's Yeoman,
Master of the Band,
Schoolmasters,
Ship's Writers,

to rank next after the Master-at-Arms.

Carpenter's Mates,
Machinists (2d class),
Armorers,
Sailmaker's Mates,

to rank next after Gunner's Mates.

Coppersmiths,
Painters,
Ship's Corporals,
Captains of Hold,
Ship's Cook,

to rank next after Captain of Afterguard.

The following are known as the *rated men* of the ship, Viz.:

Electricians,
Blacksmiths,
Lamplighters,
Carpenters,
Caulkers,
Bugler,
Jack-of-the-Dust,
Baymen,
Tailor,
Officers' Cooks and
Stewards.

Strictly speaking, all men above the rating of seamen

291

are "rated men," but the above distinction is commonly made in the service.

For the uniform of enlisted men and petty officers see U. S. Navy Regulations, page 195.

The Bureau of Equipment supplies to each vessel a printed Watch, Quarter and Station Bill, which is so arranged as to furnish a uniform system for all ships in the service.

With continuous service men the advantage of such a plan is apparent; for men transferred from one ship to another, or re-enlisting, carry with them a knowledge of the stations and duties which are similar in all vessels.

The Watch Bill is the first one made out, and is the basis of all the bills that follow.

The crew as a whole are equally divided into two watches, *starboard* and *port*. In ordinary types of cruising vessels the working force on deck is distributed as forecastlemen, fore, main and mizzen topmen, and afterguard.

In the Watch Bill the station numbers for these different "parts of the ship" are divided into *hundreds*, the corresponding number in each hundred representing a similar rate as far as possible and embracing similar duties.

Odd numbers are assigned to the starboard watch, *even* numbers to the port watch. Each watch is further divided into halves, called "quarter watches," the first half containing the first and second sections of the watch, and headed by the petty officer, captain of the part of the ship. The second quarter watch, comprising the third and fourth sections, headed by the second captain.

Thus, the forecastlemen, whose numbers run from 1 to 100, are divided as follows:

STARBOARD WATCH.
(Odd Numbers.)

PORT WATCH.
(Even Numbers.)

First Quarter Watch

First Quarter Watch.

1 to 23, First Section

2 to 24, First Section.

25 to 49, Second Section

26 to 50, Second Section.

Second Quarter Watch

Second Quarter Watch.

51 to 73, Third Section

52 to 74, Third Section.

75 to 99, Fourth Section

76 to 100, Fourth Section.

The leading numbers in each quarter watch are assigned to the petty officers, then the seamen, ordinary seamen and landsmen in the order named.

Thus, in the starboard watch of forecastlemen, 1 and 51 are first and second captains, 3, 25, 53, 75 are seamen.

To watch men by the Navy Watch Bill their names are written opposite the numbers, filling out first the leading

292

numbers of the first and third sections, then the leading numbers of the second and fourth sections. Thus a ship having ten (10) seamen on the forecastle, five (5) in each watch, and having filled the numbers 1, 2, 51, 52 with the names of the first and second captains, to watch the rest fill the numbers in the following order: 3, 4, 53, 54, 25, 26, 75, 76, 5, 6. It will be observed that the numbers show how extra men are stationed, by repeating the process. Were two more seamen added to the forecastle they would be given the numbers 55, 56, two additional ones 27, 28, and so on.

Each part of the ship is filled up in like manner. After all available men are entered in the watch bill, the remaining number of each part are vacant numbers.

Stations at loosing and furling are given in the watch bill. As these evolutions form the basis for all others, the men are assigned to such numbers and thereby placed in such stations as they seem best adapted to fill.

With the watch bill of the ship there is sent from the Bureau of Equipment the complement list, showing how many men of each rating will be supplied to the vessel. From this complement list is framed the Force bill, which serves as a guide in distributing the men of various ratings to the different parts of the ship.

We next proceed to the selection of the line petty officers. These men are appointed from among those seamen whose characters and capacities have entitled them to advancement to these stations, where they are intrusted with much responsibility and authority, and are expected to set an example to the rest of the crew, in their general deportment and attention to their duties. By ascertaining the length of time each man has been at sea and in the service, the stations they held in the last vessel to which they belonged,

being governed also by their general bearing and appearance, a fair selection can be made in distributing these men to their stations. It is a good plan to fill the petty offices temporarily, so that obvious mistakes may be corrected, and to put the men upon their good behavior when their cooperation is most needed.

In this connection particular attention may be drawn to the value of the continuous service certificate in determining the positions which the bearers are best qualified to fill.

The seamen are distributed to fill the most important stations in a similar manner. The balance of the crew fill the remaining numbers allowed. Care must be observed in assigning to each watch an equal share of the strength and intelligence of the crew.

On the forecastle are stationed able seamen-men acquainted with all the duties of a sailor-together with a few ordinary seamen and apprentices.

In the tops are stationed seamen, ordinary seamen-active,

293

able-bodied men-and a few boys of the first class to handle the light sails.

The afterguard contains comparatively few seamen from among the older seamen not otherwise stationed, also a few ordinary seamen, the balance being landsmen.

Apprentice boys should invariably be stationed in the tops or on the forecastle. They should in no case be employed as permanent messengers, &c., as they are sent to sea for the special purpose of learning a seaman's duties.

Mastmen, who attend the gear at their respective masts, may be elderly seamen who, though incapable of performing heavy work, can fill these stations well, but they must be sufficiently active to insure the prompt leading out and handling of the running rigging under their charge.

Quartermasters are selected from among the best helmsmen. They should be expert with the lead and at signals.

The boatswain's mates, being the leading men of the watch, should be thorough seamen and the men best qualified for the position of a seaman petty officer.

The foregoing remarks refer exclusively to what may be termed the working force on deck. A vessel of war contains in addition an engineer's force of first and second class firemen and coal heavers, with machinists as petty officers. This force is usually divided into three watches when steaming.

The marines of a ship are divided between the two. watches, and their work on deck is generally the same as that of the afterguard. They stand regular watch at sea.

The mechanics, musicians and servants are generally watched in the afterguard.

Idlers are such as stand no night watches, having day duties to perform of a peculiar nature, such as master-at-arms, yeomen, cooks, officers' servants, &c. These men, though not required to keep a regular watch, have stations allotted to them in all the evolutions.

There are a number of officers in all vessels who are termed idlers, viz.: The captain or commander, first lieutenant or executive officer, navigator, paymaster, surgeon, marine officer, chaplain, clerks, and the midshipmen who are stationed on the lower decks. They keep no watch, but are on duty during the day.

The watch bill should show, in addition to the man's number, &c., as above described, his boat, mess, gun or division, and company.

Boats' Crews should be taken equally from the different parts of the ship, so as not to weaken one part more than another, remembering that some boats are much more frequently used than others. Life-boat crews are always picked men. Coxswains are assigned to the usual running boats; other boats, launches, &c., are placed in charge of captains of tops or of the forecastle. The dingy is usually

294

in charge of an apprentice, its crew being composed of boys.

Service boats are called away either to perform ordinary duties of transportation, to abandon ship in case of disaster, to carry an armed crew for service afloat, or to land their crews for operations on shore.

In making up boats' crews, if the boat is manned for ordinary duty exclusively from one or two guns' crews, the fighting crew and small-arm company will consist substantially of the same men, and by assigning the division officer to that boat the men will be under the same supervision in all operations. In this case, in "abandoning ship," the boat's crew remains as before, and the balance of the division, with other men not belonging to boats' crews, are added to the extent of the boat's capacity.

Should this system be objected to on the ground that the calling away of any one boat destroys the efficiency of one or more guns' crews, then there will have to be two "crew lists" made out—one for ordinary running boats, and the other for abandoning ship and for armed service afloat and ashore. The objection does not seem valid, but it holds good in many ships.

In making up the crews of gigs and barges it is well to remember the possible absence of these boats during port evolutions, and to avoid leaving important stations unfilled from this cause.

Berthing requires the earliest attention, and the operation may be facilitated by having a plan of the decks, showing the hammock hooks of every available berth. The watches should be distributed equally on each side of the ship, so that when one watch is piped up the other will not be left entirely on one side. Boatswains' mates and men liable to a call at any time of the night, should be placed near the hatchways; quartermasters, marines, and others who keep watch and sleep in the morning, placed where they will not be disturbed after all hands are called.

On board a frigate the berthing is generally as follows: Berth deck: servants and stewards, starboard side forward; balance of the starboard side, idlers (except carpenter's gang, ship's corporals and quartermasters); port side, forward, engineer's force; aft, marines. Gun deck: forward, forecastle men; starboard side, main topmen and after-guards; port side, fore and mizzen topmen; or the numbers of the above parts of the ship may be run continuously athwartships, beginning forward, after having first selected billets for the men required in particular places.

Carpenters' mates and carpenters should be berthed near the pump, sail-makers' mates and captains of holds as near the hold or sail-room as possible, cook near the galley, &c.

At least one boat's crew should be so berthed in port, as to be readily called at a moment's notice.

295

The boys of the ship must be berthed together, and separate from the rest of the crew; usually aft on the gun-deck in charge of a corporal.

On a tack over the forward hammock hook of each billet is hung the number corresponding to the hammock, neatly painted on a small tin plate. The hammock numbers correspond with the watch numbers. These numbers are stencilled on a piece of canvas, in *black* for starboard watch, *red* for port watch, and sewed on the outside of the hammock.

In a single-decked steamer, forecastle men and fore-topmen are berthed under the topgallant forecastle.

A hammock should contain a mattress and mattress cover, and a pair of blankets.

The men should not be allowed to keep their oilskin jackets or hats in their hammocks. Temporary jack-stays along the gangways or between the launches at sea will afford a proper place for hanging these articles.

Hammocks are lashed up by taking seven marling turns with a manilla or white rope (untarred hemp) lashing. Every hammock should have three good nettle stops on the head, for stopping on the girtlines, and two on the foot. Some officers prefer having the stops put on the girtlines, but this is objectionable, as the line stretches.

As hammock girtlines are usually fitted to trice up alongside the masts, the rule for stopping on hammocks is with the numbers "up and out;" but any change in the manner of tricing up girtlines would change the rule.

A regular station-bill for stopping on hammocks, especially on board large ships, conduces to order and saves time and annoyance.

Bedding should be aired once a week. To air bedding the hammocks are unlashed, slung by the lashing and triced up in the lower rigging.

Hammocks are scrubbed at least once a month; clean hammocks having been issued the evening before, so that they may be "slung" and the old ones prepared for scrubbing in the morning.

A complete set of clean hammocks should always be on hand. After scrubbing, they are turned in by guns' crews, each one carefully inspected by the officers of the divisions, to ascertain if all have been properly scrubbed, then rolled up, placed in a bag or case having the gun's number painted on it, and taken to the sail-room, where the sail-maker receives it. A torn or badly stained hammock should be left out and given to the sail-maker's mate, to be exchanged.

Hammocks stow in their own parts of the ship; a gauge to level them at the right height above the rail, and a hoop through which they are required to pass, being sometimes used.

296

Each man is required to have two mattress covers.

Messing. The crew is divided into messes of twelve or fourteen members each. Each mess has its own cook appointed from among their number, who draws the provisions, takes care of the mess-gear, and cleans the berth deck.

Each part of the ship messes by itself, as far as possible.

Petty officers mess by themselves and employ *steady cooks*, that is, men of inferior rating, who for certain considerations (generally the value of a ration) take charge of the mess for an indefinite time.

The present complements only allow for each vessel a number of landsmen sufficient for servants, berth-deck cooks and landsmen of engineer's force. Hence the system of steady cooks throughout the messes may be considered as adopted, excepting only such changes as may be made between fire-room and berth-deck landsmen.

Steady cooks under a good master-at-arms soon become thoroughly drilled in their duties, keep the messes in good order, and the berth-deck dry and clean. In this respect they are desirable. If in addition they are kept up to the mark in personal neatness and in knowledge of their duties at drills, and in working ship, the most serious objections to their employment will be met.

The messes are usually arranged as follows:

Forward, the fore-castle messes, followed by those of each part of the ship in succession-starboard watch, starboard side; port watch, port side. Aft on the starboard side, the mechanics' messes (for rated men), petty officers' messes and *appointed officers' mess*; master-at-arms, orderly sergeant, yeomen, apothecary, and machinists.

The after messes on the port side are those of the firemen and marines.

Mess bills or small store requisitions are made out once a month, by the mess cooks. They contain the list

of minor articles, such as tobacco, soap, cap-ribbons, sewing-materials, and mess traps, that the men wish to draw. These are served out to the mess cooks in the presence of an officer, and distributed to the messes.

Each mess has its mess-chest, which contains, in addition to the mess-gear, canisters for coffee, sugar and other groceries.

Mess-chests are kept on the berth-deck.

Salt pork or beef, when issued, is marked with a skewer bearing a tag with the mess-number on it, and placed in the harness cask near the galley. Neither meat nor vegetables are allowed to be kept below.

The issue of provisions usually takes place in the afternoon watch, and should be witnessed by an officer. Any complaint concerning the quality of the ration, is made at the mast, by the mess cook.

297

The berth-deck is kept clean by the mess cooks, who are excused from work in their own parts of the ship, except at all hands, and from anchor watch in port. They are also excused from duty in boats, when they can pull a fair oar. At sea, especially when short-handed, they are required to stand night watch.

That the men's meal hours should not be interfered with, excepting in cases of actual necessity, is an old established rule of the service, and a good one. There are few more justifiable causes of discontent than frequent calling away of unnecessary boats at meal time, or prolonging "all hands" work until the crew are sent below to a cold dinner. A little attention to minor matters of this kind will go a long way to securing the satisfied condition among the crew which ensures prompt and cheerful obedience to orders.

Clothing. Each man is expected to have the following clothing, viz.:

- 2 caps, one of which shall be a mustering cap.
- 2 cap-covers.
- 1 black silk handkerchief.
- 2 suits of blue, one of which shall be a mustering suit.
- 3 suits of working clothes.
- 2 undershirts.
- 2 pairs drawers.
- 2 pairs socks.
- 2 pairs shoes.
- Badges and watch-marks, as per regulations.

Also:

1 monkey jacket, or 2 suits white, according to the station or season of the year.

Oilskins are desirable, and should form a part of the uniform, provided a suitable place is made for their stowage, such as pigeon-hole racks under the topgallant forecastle (U.S.S. Vandalia), or jackstays

between the boom boats.

Each piece of clothing should be marked with the owner's name, on the article itself; tape labels, sewed on, should not be allowed.

Division officers are responsible for the appearance of their men and the condition of their clothing.

When a division is formed, or men join it, a list of their clothing should be taken by the division officer to serve as a guide in making out clothing requisitions. The clothes list should be kept corrected to the date of the last requisition.

Clothing requisitions are made out once a month, and should be preceded by a bag inspection. The issue of the clothing should be witnessed by the division officer, and all new clothing marked as soon as received.

Habitual slovenliness, if tolerated, constitutes a direct

298

reflection upon the officers under whose immediate charge the offender is placed; for that reason division officers should spare no pains to keep their divisions up to the mark in matters of personal neatness, as well as in points of drill and instruction.

For petty officers' badges, see Navy Regulations.

Bags (containing the men's outfit). Each man is allowed two; one of white canvas, and one of painted canvas, the former being kept in the latter. They are marked on the side and bottom with the owner's "ship's number." A small grommet stitched on the bottom of the bag encircles the latter mark and keeps it from being rubbed off.

The ship number is used in marking bags so that when a man is shifted from one part of the ship to another his hammock number alone is changed.

The arrangements for stowing bags should engage the serious attention of the executive officer, for on it depends much of the comfort and health of the crew. They must be easy to get at, at any time, for the purpose of shifting in dry, working, or mustering clothes; stowed so that any one bag can be readily obtained, present a uniform and neat appearance, and be measurably secure from theft.

Bags are stowed in large ships in bag lockers, the key being kept by the mess cook. The bottoms of such lockers should be well clear of the deck on uprights, and the sides formed of slats to admit light and air; or the bags are hung on jackstays or stored in bag rooms, the latter a very poor plan.

When there are no peacoat lockers (in the nettings), there should be peacoat bags for each watch and part of the ship.

The crew dress for the day during the breakfast hour. It has been found very convenient to have a board arranged with slips, on each one of which is painted the name of an article of uniform, as "white frocks," "blue trousers," &c., and the slips arranged as the uniform for the day requires. The slips being properly arranged, the board is hung in some conspicuous part of the ship, as at the main-hatch or scuttle-butt, near the bulletin board.

Before "quarters for inspection," the bags should be neatly stowed, and not touched again until supper, when the crew shift in blue woollen clothes for the night. As a general rule, no one is allowed to have his bag out of the regular time but by permission of the officer of the deck.

The men should be allowed to have their bags at least once a week, for the purpose of overhauling, mending, marking, and airing their clothes. Saturday afternoon is generally devoted to this. When circumstances admit, bags are piped up twice a week, and Wednesday given for

299

the same purpose. The men should also be allowed their bags as soon after serving out clothing as possible, that each new piece may be marked or altered, before stowing away. If the crew are not allowed frequent access to their clothes, they cannot be expected to keep them in good order.

Ditty-Boxes contribute much to the comfort of the men, and are allowed. That they may not become a nuisance, they are made of prescribed dimensions, and a definite place is assigned for their stowage.

DUTIES OF MEN IN DIFFERENT PARTS OF THE SHIP.

Boatswain's Mates, in working with the watch, pass all orders given by the officer of the deck, and give the signal by pipe for veering, hauling or belaying in accordance with these orders. Working at all hands, they are stationed at a mast or in the gangway, to communicate, *by pipe*, the orders of the officer in charge at that station.

Forecastle Men rig and unrig the bowsprit, jib-boom, flying jib-boom, fore-mast and fore-yard.

Bend and unbend, loose and furl the head-sails, fore-sail, lower, and topmast studding-sails.

Reeve and unreeve, overhaul and hook cat and fish; pass ring-stopper and shank-painter, lash cables for clearing hawse, and stow anchors.

Lash fore-runners and tackle; hook the top-tackle blocks to top-pendants and reeve fore-jeers.

Turn in fore-rigging, reeve laniards, set it up; spar and rattle it down; and set up futtock rigging.

Attend in lighters to sling stores, &c., and keep the upper deck clean from head to foremast. Take the weather wheel.

Take the starboard lead when working with the watch.

Fore-top Men, reeve and unreeve top-pendant; fit and reeve all standing and running rigging above the top.

Bend, unbend, loose, reef, and furl fore-top sail, topgallant sail, and royal; main top-mast and top-gallant stay-sails, set and take in fore-top-gallant studding-sail, and hook the burton for top-mast studding-sail.

Shift fore top-mast and top-gallant-mast, topsail, and top-gallant yards, and put whips on yards and stays. Set up top-mast and top-gallant and royal backstays.

Bitt, unbitt, or stopper when working the cables. Keep fore-top and fore-channels clean and in order, and clean port gangway. (Main-topmen clean starboard side.)

The duties of fore and main-topmen are much, the same

300

in their respective tops. Working with the watch a maintopman takes the lead in the port channels.

The peak of main-trysail belongs to the main-topmen.

The Mizzen-topmen have nearly the same duties. They loose and furl the peak of the spanker, clean and keep in order the port channels and port side of quarterdeck and poop.

The After-Guard have the care of the starboard side of quarter-deck and poop, and starboard mizzen channels.

Bend, unbend, loose, reef, furl, and shift the main-sail,* main-trysail, and spanker. Look out for the mizzen rigging and cross-jack yard. Hold the reel and haul in log-line.

The Quarter Gunners rig and unrig main mast and main yard; turn in, set up, spar and rattle down main and futtock rigging.

Bend, unbend, loose, reef, and furl main-sail, main-staysail, and main-topmast studding-sail; attend lower studding-sail out-haul and after-guy; the fore-topmast studding-sail tack, and broom-brace, main tack, and sheet.

Reeve main-jeers, hook main-top tackles. Look out for sheet anchors and attend at capstan when heaving in.

Look out for battery, ordnance stores, and life-buoys.

Quarter-Masters, being generally main-yard men, work on main yard and in main rigging. To them belongs everything appertaining to the sounding and steering gear, and signals.

At sea they always *con* ** the ship, and attend at the heaving of the deep-sea lead and the log.

Carpenter's Mate and Carpenter's Gang rig and unrig capstan and pumps, clean pumps and skylights.

Idlers, Firemen, Marines. In working with "all hands," cooks and stewards and firemen are generally stationed to assist forecastle men in manning gear; servants man gear of fore-top-sail; mechanics, gear of main-sail, and marines divide at the gear of main and mizzen top-sails.

Ready Men were at one time considered necessary aloft, to make preparations for the different evolutions, but their use has been greatly modified, and on many ships given up altogether.

The call for these men invariably sends more hands aloft than are allowed, and they mar the effect of drills by their efforts to "get ahead" of other tops or competing vessels.

The test of efficiency in performing an evolution is the time that the men require aloft to perform it properly, and

* This applies only to those of the after guard who are stationed on the main yard.

** *Con*-from *conduire*, to conduct. To direct the helmsman how to steer.

301

the extra time taken up with "ready men" above the rail is greater than when they are dispensed with.

Top-keepers, &c. Each top has a top-keeper; it is his duty to keep the top and top-chest in order, to see the latter closed when not in use, and the cover stopped down, also to lay aloft and send down whips, &c., when required.

Each part of the ship supplies a chain-keeper, who keeps the chains clean and the wash-deck gear properly stowed in the chain-chest.

The Quarter Bill. For duty in action the men are distributed at the guns, or assigned to the Navigator's division as wreck clearers, &c., or to the powder division to provide ammunition.

To secure the ability of the watch on deck to prepare and work half the guns at night while the watch below are stowing hammocks or doing other necessary work, all odd-numbered broadside guns are manned by men of the starboard watch, even-numbered guns by the port watch; pivot gun crews usually half from each watch.

A gun's crew is formed of about one-third petty officers and seamen, one-third ordinary seamen, and one-third landsmen or apprentices.

The gun captains are selected from those in whose skill and judgment the greatest reliance can be placed, and with good eyesight; second captains are selected upon the same principle; spongers and loaders rank

next in importance, and should be strong, active men.

In distributing the petty officers and men to guns and other stations, those stationed at the same gun or near each other at quarters are drawn from *different* stations in working ship, so that a great loss at any one gun will not fall too heavily on any watch station.

Exception to this rule may be made where the duties of men require their habitual presence on particular decks. In such cases it will be generally advisable to station them at quarters near the places of their ordinary duties.

For the first division of boarders will be wanted the most effective men; for sail-trimmers, men stationed on the spar deck; at the wheel, the best helmsman in the vessel; at the relieving tackles, an officer or quartermaster, with a few men to steer the vessel in case the wheel or tiller-ropes are shot away. In the magazine is stationed the gunner and his mates, and the cooper. Select for the stations below, for passing powder, shot, &c., those who may be least effective on deck, but with a quota of reliable men sufficient to insure a prompt and full supply of ammunition.

Have in the navigator's division, to attend the stoppers and to remain in the tops, active topmen.

The first lieutenant, under the direction of the commander, works the batteries, while the navigator, under

302

the direction of both, and assisted by the boatswain on the forecastle, attends to the manoeuvres. The other lieutenants are stationed, one to command each division. The marines, under command of their officer, are in the waist, or on the poop. and often some are stationed in each top, to annoy the men at the enemy's guns. The midshipmen are distributed about in the tops, and at the divisions, to the best advantage.

In the *Ordnance Manual*, to which the student is referred, may be found the most carefully arranged quarter bills, and full instructions for quartering a crew. In this volume will be found (page 257, Arts. 935 and 936) the method of manning boats when the crews are to be disembarked under arms. This plan has for its great advantage the fact that the same men are always associated in the division and company, and under the same officer.

The Station Bills as supplied by the bureau are arranged for working either with the *watch* or with *all hands*, and their scope renders them available for any full crew in the service on board ordinary vessels, whatever their size. Should the ship's crew be materially below the complement allowed, some modifications may be required in the stations.

Stations for work aloft are so arranged as to give each man about the same amount of canvas to handle. Each station is filled by an equal number from each watch, so that with but one watch on deck the vessel may be worked and all stations manned. This divides the force, and there are an equal number of men on each side of the deck at the gear or aloft.

As it is of the greatest importance that the ropes on deck, other than those tended by mastmen, should be

tended by intelligent men, the coxswains or second captains of tops are retained on deck except at bending and reefing, to attend the gear at the sides and point out ropes to be manned. This does away with much calling from aloft, which should always be avoided.

Combination station bills show the duties of *each man at all evolutions*, and copies of the same are posted up in conspicuous parts of the ship.

The Fire Bill should be prepared as soon as the organization of the crew is completed by the assignment of their duties on the watch, quarter, and station bills. It is necessarily a work whose features must be adapted to the particular arrangement of the ship, but it should, as far as possible, conform to the arrangement for extinguishing fire during exercise at quarters. Much confusion will arise from requiring different duties from the same person at ordinary "fire quarters," and in case of fire when at general quarters.

Directions for stationing the crew as firemen, pumpmen,

303

smotherers, &c. will be found in the Ordnance Manual, and the ship's fire bill may be said to be based upon the quarter bill.

Blank forms of billets are filled out for each member of the crew, and show his station at all evolutions, also his boat, gun and mess. These billets are printed on strong paper, so that the men can keep them in their caps without wearing out too soon.

FORM OF BILLET GIVEN TO EACH ONE OF THE CREW WHEN ABOUT TO COME ON BOARD.

203

MAIN TOPMAN.

STATION BILLET.

<i>Name</i> , JOHN BROWN;		<i>Rate</i> , SEA;
<i>Division</i> , 2;	<i>Gun</i> , 5;	<i>No. at Gun</i> , 3;
<i>Boat</i> , 1st Cutter;	<i>Company</i> , 2;	<i>Mess</i> , 6.

EVOLUTION

STATIONS AND DUTIES.

Loosing sail	Loose topsail.
Furling sail	Furl topsail.
Bending sail	Topsail-yard, overhaul gear, bend topsail.
Up and down topgallant and royal yards	Topsail-yard, rig lower topgallant yard-arm.
Up and down topgallant-masts	In top, come up and set up rigging.
House and fid topmasts	Fid and unfid mast
Shifting topsail yards	Topsail-yard, unbend and bend topsail, unrig and rig yard aloft.

Up and down lower yards	In top, lash upper jeer-block.
Out and in boats	In top, and receive and hook triatic-stay.
Mooring and unmooring	Tend stoppers; bitt and unbitt cable.
Making sail and getting underway	Loose topsail, then on deck to halliards.
Bracing up and setting courses	Man main-topsail and upper braces.
Tacking and wearing	Man weather main-topsail and upper braces.
Reefing topsails	Topsail buntlines, reef topsail, on deck to halliards.
Shortening sail and coming to anchor	Man topsail clewlines, veer and stopper cable.
Clear ship for action	In top, send down light spars, snake down back-stays.

RECEIVING THE CREW ON BOARD.

Under the present system, the men are kept on board the Receiving Ship until the vessel fitting out is so far

304

advanced as to be ready to receive them. No pains should be spared to get a good master-at-arms and ship's cook, and it will be greatly to the interest of the executive officer if he can procure a good painter, cooper, shoemaker and tailor.

The executive officer can have his crew mustered on board the Receiving Ship at pleasure; he therefore should lose no time in selecting his petty officers and making out the watch-bill, berthing and messing the crew. Mess cooks should be selected, and the master-at-arms and ship's cook should go on board to see if all the galley arrangements and mess-chests are complete. It is found convenient to take the men from the Receiving Ship after dinner, as it is easier to have supper the first meal to be prepared on board their own ship. When the watch-bill is complete, it will take a good clerk but a few hours to fill up the billets. If these are given to the men before leaving the Receiving Ship, they can shoulder their bags and hammocks, march on board their own ship, stow their hammocks in their proper netting, their bags in their own mess, and go to "general quarters" the next moment, if need be.

Watches, Look-outs, &c. The twenty-four hours are divided into seven watches, as follows: mid-watch, midnight to 4 A.M.; morning watch, 4 to 8 A.M.; forenoon watch, 8 A.M. to noon; afternoon watch, noon to 4 P.M.; first dog, 4 to 6; second dog, 6 to 8; first watch, 8 P.M. to midnight.

The division of the time from 4 to 8 P.M. into *two* watches makes the total number of watches an odd number. By this arrangement the men (who stand watch and watch at sea) are given eight hours out on one night and only four on the next night.

In port, the crew are all available for duty throughout the day, and an "anchor watch" of one or two hands from each part of the ship is kept at night.

At sea, between sunrise and sunset, there is a look-out kept at the fore topmast-head, relieved every two

hours and taken in turn by a hand from each part of the ship.

Between sunset and sunrise the look-outs are generally as follows:

Starboard cat-head, a forecastleman,
Port cat-head, a fore-topman,
Starboard gangway, a main-topman,
Port gangway, an afterguard,
Starboard quarter, an afterguard, or marine,
Port quarter, a mizzen-topman.

In passing the hail, which is done every half hour, the look-outs call the name of the station in regular succession.

When a quarter-watch is aloft (with stunsails set), one hand in each top keeps a look-out and passes the

305

hail. Under certain circumstances of weather (low-lying fog, &c.), a forecastleman may be stationed on the fore-yard.

Men may also be stationed on the main and main-topsail yards to guard against sparks from the smoke-hack.

The look-outs on the quarters are also responsible for the life-buoys, and should know how to light and detach them.

When under square sail, there is a hand stationed at each of the halliards of the loftiest sail carried; in squally weather one stationed also at the main sheet. These men pass the hail at night with the other look-outs.

Wheel and look-outs are relieved every two hours; in bad weather it is well to reduce this to one hour.

At night the watch below is called fifteen minutes before the hour when they should "lash and carry," bringing their hammocks on deck and stowing them. When the wheel and look-outs have been relieved, the other watch get their hammocks and are sent below.

In stormy weather, or when otherwise unavoidable, all hammocks are sent below, or the objectionable practice must be tolerated of "turning in and out."

Conduct Books, &c. In regulating the privileges of the men, a set of books are kept under the direction of the executive officer. In the *report book* are entered the names of the men, offences committed, the name of the person Making the report, and the punishment inflicted by the commanding officer after the matter has been investigated "at the mast."

The conduct book contains the division of men into four classes, in accordance with their behavior while on board ship and ashore.

From their standing on this record, the men's names are placed more or less frequently in the liberty book, which shows the length of liberty allowed, the time of returning and the condition in which the man returned. The remarks are to be filled in by the officer of the deck.

The **routine** of the ship is based upon the amount of cleaning or other work that is daily required; it sets apart the meal hours, and periods of exercise.

The form of daily, weekly, and monthly routine adopted in the service, will be found in Appendix G.

It necessarily varies in port and at sea, and also to a certain extent for the different seasons of the year.

A form of routine for divisional and other drills will be found in Appendix G.

While it is eminently desirable for each person on board ship to know what he has to do, and when it is to be done, the peculiar nature of a seaman's duties make any routine objectionable which cannot be modified when necessary. Bad weather or unusual and exhaustive work may require

20

306

a suspension of the ordinary daily duties, and no routine is of permanent value unless it admits of such variations.

On the other hand, unless the executive is *methodical* in conducting the duties of his ship, whatever may be the routine adopted, a want of system on his part will neutralize any efforts for the maintenance of proper discipline.

Besides organization proper, there are certain other essentials which belong to every well-ordered ship.

Cleanliness, for example, is absolutely indispensable, and as it bears directly upon health, should receive every attention.

Lord Collingwood says, in one of his letters, "I have been long at sea ... Yet, with all this sea-work, never getting fresh beef nor a vegetable, I have not one sick man in my ship." And his memoirist adds; "Lord Collingwood carried his system of arrangement and care to such a degree of perfection, that perhaps no society in the world, of equal extent, was so healthy as the crew of his flag-ship. She had usually eight hundred men; was, on one occasion, more than a year and a half without going into port, and during the whole of that time never had more than six, and generally only four on her sick list. This result was occasioned by his attention to dryness (for he rarely permitted washing between decks), to the frequent ventilation of the hammocks and clothes, to the creating of as much circulation of air below as possible, to the diet and amusement of the men; but above all, by the contented spirits of the sailors, who loved their commander as their protector and friend, well assured that at his hands they would ever receive justice

and kindness, and that of their own comforts he was more jealous than of his own."

These few sentences contain a fund of good advice, and are commended to the attention of those destined to command our ships.

Silence is one of the evidences of good discipline, and the crew soon acquire the habit, if properly instructed by the *precept* and *example* of the officers. Hailing the deck from aloft, giving orders in an unnecessarily loud tone, and useless repetitions of commands, should not be tolerated.

There is no reason why the pipe and signs should not be substituted for the shouting that unfortunately distinguishes some men-of-war.

In this connection it may be observed that at the bugle call for "*silence*" every soul on board should obey the order thus conveyed, standing fast and keeping silent until the call to "*carry on*."

If the imperative nature of the "*silence*" call is to be impressed on the minds of the men, the officers and petty officers must be the first to obey it.

307

Alacrity is another essential; the crew should be accustomed from the first to move smartly about the decks when on duty, and when all hands are summoned they should go up the ladders on the run. To insure promptness in the carrying on of duty, it is well to remember that the force of example goes a great way. *

* For Notes on Preparing Ship for Sea, see Appendix G. They are to a great extent a repetition of points dwelt upon in previous chapters, but classified in a different form.

CHAPTER XIX.

DUTIES OF MIDSHIPMEN.*

STEERAGE officers (of the line) on board ship are generally assigned to duty as officers of the forecastle, midshipmen of the quarterdeck and tops, mates of the decks, hull and hold, boat officers and junior officers of the divisions.

A midshipman may also be detailed as assistant to the navigator, or as clerk to the commanding officer; in one of the latter capacities he will probably also act as signal officer.

All junior line officers who perform the above-mentioned duties are allowed such practice in charge of the deck and in the engine room as their numbers and the nature of the cruise permits. The Navy Department defines the amount of such practice and the nature of the reports made upon the subject by commanding officers.

For navigation work required of midshipmen, see Navy Regulations.

Duties of Forecastle Officer in Port. Salute the officer to be relieved, who will return the salute. Pay strict attention while receiving any orders that may have to be passed, and *after* receiving all instructions, announce your willingness to relieve.

The forecastle watch is generally stood on the topgallant forecastle, if there is one; and the forecastle officer is usually held responsible for work going on, and neatness, as far aft as the main hatch.

As officer of the forecastle you must see the forward part of the ship kept clean and in good order. Do not permit the men to sit on hatch coamings, in the ports or on gun-carriages, or rest their feet on the paint-work. Do not allow wearing apparel, to lie about the deck or be stowed in improper places. Do not allow bags on deck without the permission of the officer of the deck. Do not allow the sweepers to sweep dirt down the scuppers or throw it over the ship's side; it must be emptied in the ash chutes, or in the head. Keep shore boats clear of the forward part of the ship. Preserve order amongst the crew without interfering in their proper amusements. Do not allow any man on the forecastle after colors who is not in proper uniform;

* Present official titles, Naval Cadets and Ensigns (Junior Grade).

309

nor any one aloft after colors without the permission of the officer of the deck. Do not allow clothes to be scrubbed outside of proper hours except by permission of the officer of the deck. See the running rigging forward kept taut except in wet weather. See that the awning stops are always taut and expended. When hammock cloths are hauled over see that the stops are not hanging down, and when rolled back that they are snugly secured and hammocks kept in neat order.

Duties in Regard to Boat Beepers. See that they sit up properly in their boats; that they rise and salute all officers in passing boats; that they keep their boats from fouling each other and the ship's side; and that they are in uniform. Do not allow them to wash clothes in their boats, nor to converse with men on board ship.

Duties in the Morning Watch. Just before all hands are called, see that the forward part of anchor watch trice up forward hammock cloths. Do not allow hammocks to be brought on deck until they are piped up. See the forward hammock stowers are in their nettings when "all hands" are called. (Hammock stowers called ten minutes before reveille.)

Have the men under topgallant forecastle turn out and lash their hammocks promptly. All hammocks must be properly lashed, clews twisted and tucked snugly under the lashing. Do not allow hammocks to be thrown on deck or on the guns. Keep a sufficient number of men on deck to haul over the hammock cloths. Take the numbers of all late hammocks and enter the names on the report book.

When Hands are Turned-to after Coffee. Have all smoking stopped and smoking lamp extinguished by the corporal of the guard; the rigging laid up and wash-deck gear gotten up. Put the sweepers promptly to

work sweeping down preparatory to scrubbing clothes or the deck.

Scrub and Wash Clothes. See the order promptly obeyed, giving to the officer of the deck the names of those men who state they have no clothes to scrub. Have the white clothes scrubbed first so there may be no delay in filling the upper lines, and hurry the clothes aft when the word is passed to stop them on the line.

Duties during Cleaning Deck. See that it is thoroughly done forward, all *bright* wood work scrubbed, and such other parts of the ship as may be ordered. See that the galley cooks scrub the funnel; that the foretopmen clean the channels; that the forecastlemen fill the tanks, and that the captain of the head always keeps the head clean. After the deck is dried down see all the paint work, hatch coamings, port sills, &c., wiped off: Have the port lids squared by the quarter gunners, and

310

everything put to rights about the deck. At six bells see the forward hammock cloths triced up and hammock stowers in their nettings.

Squaring Yards. See that the men lay aft promptly to the braces. When the order is given see the proper men in the fore rigging ready to lay aloft. When they are aloft see the lift jiggers put on and the hauling part of topsail jiggers sent on deck. Be particular that no ropes are hanging over the ship's side. See that deck swabs (if used) are well wrung and hung in the head to dry before stowing away. See the scupper-valve laniards hauled taut, plugs put in, and the wash-deck gear stowed away. Have all running rigging hauled taut and neatly coiled up on the pins (if not to be flemished down). See that all gaskets on sails are square; that no Irish pennants are hanging from aloft; and that all ropes in the top are coiled down neatly so as not to show above the top rim. Have the eyes of the topgallant and royal lifts and braces (yards not crossed) stopped close in to forward part of eyes of topmast and topgallant rigging so that they will not be visible from aft, and the braces stopped along the forward horns of cross-trees and jack. The stun'-sail booms must be rigged out alike, heels square, the foretop-bowlines stopped down in the top, all buntlines and leechlines stopped down, and bunt jiggers hauled taut up. See the top chest closed. See the fore and aft tackles of awnings hauled taut and no stops hanging down. When the boatswain returns and pipes down, see that the men lay down promptly together.

Clearing up Deck for Quarters. See that everything forward is clean and in perfect order. Do not allow ditty bags, boxes or wearing apparel to lie about or be stowed in improper places. Inspect about the manger, between the beams, over the knees, on top of capstan bars and all such places. Have the master-at-arms with you in this inspection to gather up all articles of private property and put them in the lucky bag. The inspection should be thorough, so that the executive officer following after may find everything in order.

During Meal Hours. See that the mess cooks keep the deck clean around their cloths. They are responsible if the deck is soiled, and should be made to clean it unless the real offender is known. See that the mess cooks *fold their cloths once* before rolling them away.

Much of the above applies to vessels with topgallant forecastles.

Spreading Awnings. See the fore and aft tackles lowered and hauled out together, and the earings hauled out together. When the men lay up and bring-to, see the awning out flat and the ends of the stops expended so that they cannot get adrift and hang down. Do not permit the practice of expending part of the stop and

311

throwing the remainder on top of the awning. Have each order from the deck promptly obeyed, and never report until ready so that the men fore and aft may work together. The boats at the booms spread and furl their awnings with the ship.

Cleaning, Bright Work. See that tarpaulins are spread and the bright work cleaned on them, that the deck may not be soiled. Send the men to their divisions. At the sound of the retreat stop all cleaning forward, and see that quarter gunners put away the cleaning gear.

ADDITIONAL DUTIES OF THE OFFICER OF THE FORE-CASTLE AT SEA.

He is responsible that the men forward remain on deck during their watch, and must see that the lookouts are vigilant, a bright lookout being always kept. When land, vessels, lights and other objects of importance are seen he must promptly report them to the officer of the deck. He must see that the running lights are kept burning brightly. (The captains of the fore-castle, fore and main tops attend respectively to the mast-head, port and starboard lights). He must see the head yards and sheets are kept properly trimmed, the sails well set. He must see the gear coiled down clear for running and everything in readiness to shorten sail at an instant's notice. He should always have on watch with him a pocket station bill of the fore-castle men and fore-topmen, to become familiar with every man and his station in both those parts of the ship. He musters the whole watch when there is no midshipman of the quarter-deck, otherwise he musters only the forward part. The duty of heaving the log and filling up the columns of the log-book *hourly* is performed by the officer of the fore-castle when there is no midshipman of the quarter-deck.

DUTIES OF MIDSHIPMAN OF THE QUARTER-DECK IN PORT.

He stands his watch on the port side of the quarter-deck. He receives and attends at the departure of all appointed and warranted officers, and attends with the officer of the deck at the reception and departure of all commanding officers. He sees that all orders of the officer of the deck connected with the after-part of the ship are promptly executed. He must attend to the manning of all boats, being careful to observe that the crews are dressed neatly in the uniform of the day, having on their knife lanyards, shoes, and cap ribbons, and that the boats are clean and in good order. He must report

312

to the officer of the deck when the boats are at the gangway and ready to shove off. He should make frequent and careful inspections of the outside of the after part of the ship to see that no ropes are hanging over, that the chains and gangway ladders are clean, and that the outside of the ship always presents a neat and trim appearance. He should see that the ends of hammock stops are kept tucked away neatly, and that the ends of awning stops are expended and secured; should be attended to when spreading awnings the ends will not get adrift if they are wound around all parts of the stop between the ridge and bolt ropes and the ends finally tucked into the eye of the splice. He must not permit any one to go aloft after colors without the permission of the officer of the deck. He must see that the sweepers wipe off their ladders after sweeping down in the forenoon and afternoon watches, and that they keep their spit kids clean. He must see that the officer of the deck is promptly informed of the approach of all boats, particularly of men-of-war boats. After a davit boat is lowered he must see the falls hooked and stopped in to the davits. He musters the men at the pumps in single decked ships. He should inspect every accessible part of the ship at least once during a night watch.

ADDITIONAL DUTIES OF THE MIDSHIPMAN OF THE QUARTER-DECK AT SEA.

He musters the watch, petty officers and life-boats' crews. He sees the gear clear and promptly manned when ordered. He must see that the lookouts are vigilant, and that the man stationed at the life-buoys thoroughly understands his duties. He should see that the after-part of the watch keep on deck. He should learn as soon as possible the names and stations of the men in the after-part of his watch. He musters the men at the ash whip.

Log-Book. The midshipman keeping the columns of the log-book has an important duty to perform. He must never trust to his own judgment as to the course and speed of the ship; the officer of the deck will specially direct him what to record in both these cases. The other columns shall be filled as follows: *Wind*-the *average* direction for the hour to the nearest point. *Force*-the average for the hour except when wishing to show the force of passing squalls; for instance, when a gentle breeze has been blowing with "moderate squalls," it should be entered 3-7. In the column for weather symbols, every symbol must be used required to express all the changes of the weather for the hour. The various forms of clouds and the *average* amount of clear sky for the hour must be entered in their respective

columns. The barometer and thermometers are recorded at the heights shown at the termination of the hour. It is important that these instruments give as truthful an account of the conditions of the atmosphere as possible, and to insure this he must see that they are protected from the sun's rays, and that the wick on the wet bulb is always kept moist. This thermometer should not be recorded unless he is satisfied that the water which moistens the wick is of the same temperature as the air, for otherwise it would show only the temperature of the water. If the water were *warmer* than the air the wet bulb would show a higher temperature than the dry-an impossible condition of the atmosphere.

For other information in regard to keeping the log-book it is necessary to study carefully the pamphlet on the subject issued by the Bureau of Navigation. The meteorological data contained in log books is compiled at the Hydrographic Office for the construction of weather charts, hence the great importance that it should be correct.

DUTIES OF A MIDSHIPMAN OF A TOP.

He must go in the top when all hands are called for any exercise or duty aloft. He must preserve silence and good order aloft, and never permit any one to hail the deck. He must never hail the deck himself unless unavoidable. As soon as possible after being assigned to the top he should make himself perfectly familiar with the names, stations and qualities of each man in the top; the necessity of this is obvious. He is responsible that the men go to their stations as per Station Bill. He should never allow any changes without the authority of the executive officer, except for the time being when any important station is vacant, or for the purpose of equalizing the men on the yard arms. He must keep the men in the slings until the order "lay out," and keep them out until the order "lay in." When the order to man or attend the boom tricing lines is given he sees it obeyed *immediately*, so that all the booms shall go up or down together. When loosing sails he must see that the sails are kept well up until the order "let fall."

When making sail he must see the gear well overhauled and lighted up.

When furling he must see that the sails are not gathered up until the order "furl." He must see them neatly furled, gaskets passed square and gasket laniards tucked away securely. He must see that no ropes or Irish pennants are hanging from anywhere aloft.

When crossing light yards he must see the lifts and braces overhauled and *properly* put on, the slack of the

314

working lifts taken in, that a turn has been caught with the parrel lashing, and that the lizards are clear for slipping. In all exercises he must be sure that everything *is* ready before he reports.

When sending down light yards he must see the bunts secure, the clews stowed in or stopped to the quarter-block eye-bolts, the lizards hauled close down and well secured against slipping, and the lifts attended if they set up in the top. In bending, reefing, and all exercises aloft, he is responsible for the details. He should inspect the top every morning at 7:30 and report its condition to the executive officer. He must see that only such articles are kept there as belong in the top, the ropes neatly coiled down so as not to show above the top rim or over the lubber's-hole, and everything trim aloft. He must see the top chest is kept closed except when sails are loosed to dry, and that it contains heavers, marlingspikes, rope and spun yarn, straps, and grease pots. If there is to be an exercise at colors he must have everything in readiness.

DUTIES OF THE MATE OF THE GUN-DECK.

He must turn out in port ten minutes before reveille, and at sea ten minutes before the idlers are called. He must get on deck at once, hurry up the hammock stowers, and see the men turn out promptly when "all hands" are called. The deck should be cleared of all but six bell hammocks in ten minutes. Directly the hammocks are up he must report the same to the officer of the deck and receive from him the morning orders for the gun-deck.

As soon as the hammocks are up and the cloths hauled over, the men are allowed fifteen minutes for

coffee and smoking, after which the hands are turned-to and the corporal of the guard extinguishes the smoking-lamp.

The first thing to be done is to have the deck swept down, then the morning orders executed. If the deck is to be holystoned or scrubbed, he should have everything possible triced up clear of the deck, while a couple of hands from each part of the ship are getting up the wash deck gear. He should start the water, sand down, holystone around the guns, run them in and holystone underneath them.

The guns are run in by the different parts of the ship. The gun gear is scrubbed by those detailed in the divisional cleaning bill. The scuttle butt and harness casks by the berth deck cooks.* The galley platform, tables and chests by the galley cooks. The water-closets by the fore-castle-

* Or the scuttle butt may be cleaned by the part of the ship in which it stands, and the harness cask by the jack-of-the-dust.

315

men, who should be made to keep them scrupulously clean. The quarter-gunners, all the spare gun gear kept on the gun deck. The carpenters and painters, the pump coamings and brakes and wardroom skylight. Each part of the ship scrubs its own ladders (those leading to the berth deck). The gunners' gang wipes off the guns and their carriages, port sills and port lids, and sees the latter square.

The mate of the deck must be sure that all corners and out-of-the-way places are thoroughly cleaned, particularly about the galley and manger. He must look carefully around the capstan, and deck and stopper bolts, see the hatch gratings removed and the rabbet of the hatch coamings cleaned. Everything movable should be moved and cleaned underneath. He should search the corners and hidden places. When the order is given to pump the ship out, the carpenter rigs the pump and the mate of the deck musters the men at it.

If the crew messes on the gun deck, when mess gear is piped he must keep the men clear of the tables or cloths until meals are piped. It is a common practice for the firemen as well as marines who have the following watch to get their meals half an hour earlier. If this system is followed he should allow the privilege only to those entitled to it, being particularly careful at sea that none of the watch on deck are below without permission. The better system is to have the firemen and marines get their meals with the deck watches at sea, and when in port for the reliefs to go on duty half an hour later.

After meals he will see mess gear cleared away. At proper time the hands will be turned-to and the smoking lamp must be extinguished.

At gun bright work he must be about to see that the deck is not soiled. After bright work he should clear the deck of everybody but cooks and sweepers, when he, assisted by the boatswain's mate, must see the deck cleared up for inspection before quarters. He must see the deck swept down and everything put in order. Before reporting to the executive he must make a thorough inspection himself. He should examine over the knees, capstan bars, gun gear and all other articles triced up to the beams to see that those places are not used as stow holes. He must see the port lids square, the ports clean and dry, the scuppers clean,

the scupper valve laniards hauled taut and all plugs in. He must see that no clothing or other articles are hanging about the deck, and have all ditty bags or boxes stowed in their proper places. He must see the battery in order, all tackles made up. He must see all chests in order and that nothing is stowed behind them, chest lids raised. He must have the gratings stowed neatly on the hatches. He must have all chairs sent below. While the executive officer is

316

inspecting, the mess cooks must stand by their chests, the galley cooks by their chests or the galley.

The deck should be kept clean, spitting on it strictly prohibited. The port side, after quarters, should be kept clear except of such men as the executive officer may permit between the guns.

The mate of the deck attends at the serving out of provisions and sees that a petty officer is also in attendance. He must also attend to the clearing out of the lucky bag, the paymaster's clerk and ship's writer being also present. He must every evening report the deck ready for hammocks to the officer of the deck. His daily duty extends to tattoo in port and to 8 P.M. at sea.

DUTIES OF THE MATE OF BERTH DECK AND HOLD.

Many of the duties laid down for mate of gun deck are applicable to the mate of the berth deck. The deck is kept clean and in order by the berth deck cooks under the master-at-arms. If the crew messes only on the berth deck the work of the cooks is confined exclusively to, deck. The mate should turn out at the same time as he mate of gun deck. His duties in regard to hammocks are the same. The berth deck is seldom holystoned or scrubbed with sand; it is either wiped up or scrubbed with soap and water, the deck being either painted or shellacked as a sanitary measure. It should never be more than wiped up before breakfast. The duties of the mate when cleaning the deck are the same as those of mate, of gun deck.

He must make the same preliminary inspection and have the deck ready for the inspection of the executive officer by 9:15 A.M. at the latest. He must never permit smoking on the deck. He must not allow the men to go to their bags without proper authority. When the men are called on deck he must see the deck promptly cleared and report it to the officer of the deck.

When getting underway or coming-to he must muster the berth deck cooks at the compressors. At sea he must never allow the air ports to be opened without the authority of the executive officer and the knowledge of the officer of the deck. He should never allow wet clothing to be hung about or kept on the deck.

As mate of the hold lie is responsible that the hold is kept clean and properly stowed. All barrels must be stowed on their bilges, bungs up, well chocked and with chime pieces between the heads of those that do not match. He must see that *wet* provisions are not stowed over dry. He must see that the *old* provisions are stowed over the new and nearest the hatches. He must see that the gear in frequent use, such as cat and fish, yard and stay purchases,

stun'-sail gear, water whips, preventer braces, &c., are stowed so as to be passed up at a moment's notice. He must see that an accurate account is kept of the expenditure of water, and, if in a sailing ship, of coal also. He must see that the tanks are emptied in regular order, starboard and port, and that they are kept clean inside.

The condensing tank should be cleaned after the other tanks are filled.

He must see the holds locked and the keys turned in to the executive officer, and report the holds locked to him at 8 P.M.

The mate of the hold is generally also given charge of the hull while in port, and should satisfy himself by frequent inspections throughout the day of the proper appearance of the ship outside, notably after drills, or the reception of stores, or after bumboats have been alongside.

DUTIES OF A MIDSHIPMAN OF A DIVISION.

He assists the officer of the division in instructing the men in all duties of the different stations, and in keeping the guns properly equipped, the supply and reserve boxes complete. He should especially see to the bright work. He should always, when not on duty, go promptly to his division at the roll and see that every one is present who is not properly excused, and that they remain until he has inspected and approved of their bright work. He must see that those detailed in the cleaning bill to clean absentees' bright work perform the duty.

At quarters he receives the reports of the gun captains and reports the absentees to the divisional officer. He accompanies the latter in his divisional inspection, being always provided with pencil and paper to note any reports. He should also accompany him after the drill in his inspection to see that everything is properly secured and that all articles are returned to their proper places. While the divisional officer is absent making his reports he is responsible that order and silence are maintained in the division. During drills he must be active and observant that all the details are promptly and properly executed. He must keep a duplicate clothing bill carefully corrected at every monthly inspection of bags. He makes out the clothing requisition under the direction of the officer of the division. He must be present at the issuing of clothing.

DUTIES OF A MIDSHIPMAN OF A BOAT (ARMED AND EQUIPPED).

Obtain from the officer of the boat a list of the boat's crew, with the duties of each man for arming and equipping,

and from the Ordnance Manual a list of the equipments and the contents of the boat box.

If the boat to which he is assigned is a davit boat, he should take pride in her condition, and report immediately to the officer of the boat any injury she may have sustained or loss or damage to her fitments.

When boats are called away armed and equipped, he should endeavor to get his boat away first, completely ready for the intended service.

The duties of a boat officer in running boats have been given elsewhere. (SEE BOATS.)

Remarks. In the absence of quarter-deck midshipmen, the officer of the forecastle is generally ordered to inspect below during night watches at sea, to write up the columns of the log, muster the watches, and in general to perform the more important duties mentioned as belonging to the quarter-deck detail.

When a light is sighted forward, the forecastle officer should be prompt in ascertaining its position and reporting its bearing and color. When a sail is sighted by day he receives and transmits the report of its bearing and character, if made out.

In mustering the watch the men toe a seam in their own parts of the ship, weather side, and each man answers his name to his number when called, falling out and passing the mustering officer. Unless important work is going on, captains of parts of ship are sent to look up their absentees and bring them to the mast. The names of men sick or excused from watch are borne on the binnacle list, kept at the wheel.

The watch being mustered, proceed to muster the lifeboat's crew abreast of the lee boat, the coxswain inspects *both* boats and falls, and reports "clear and ready for lowering."

The result of the muster (absentees, &c.) is reported to the officer of the deck.

The marines of the watch are mustered by the non-commissioned officer of the guard.

All officers keeping watch are called at night ten minutes before the hour, usually by the quartermaster on duty, and they should be ready to relieve on the stroke of the bell.

Make it a rule not to turn over your duty to another until you have passed all orders and instructions required, and similarly not to relieve until you are furnished with all the information which ought to be given. Few things reflect more discredit upon a young officer than ignorance on any point of the instructions generally turned over in relieving.

When stationed in a top, lay aloft as soon as you come on deck and before the light yardmen are sent into the, rigging.

When the work is mainly on the topsail yard, as in reefing, &c., your station is on the lower cap to direct the men; at other times take position in the top where you can best superintend the work. When ready aloft signal the fact to the officer in charge of the mast by facing him and raising the right hand.

On board large ships midshipmen are required to attend at hammocks, to preserve order.

HINTS FOR NAVAL CADETS.

Correspondence. An order from the Navy Department must be acknowledged immediately on its receipt and as per form A.

When granted "leave" or placed on "waiting orders," the post-office address of the officer must be forwarded immediately to the Chief of the Bureau of Navigation and Office of Detail.

All communications to a bureau officer should be addressed by his rank and bureau title.

When an order specifies that it shall be obeyed "immediately," the officer receiving it must proceed to obey it within twelve (12) hours after its receipt. When it directs "without delay," he must proceed within forty-eight (48) hours. When no time is specified or expression of haste used, he must proceed within four (4) days.

All official communications must be written on official paper. The navy regulation paper is thirteen and a half (13 1/2) inches by sixteen and a half (16 1/2) inches when open, made of linen stock, is stop ruled with twenty-four blue lines on the first and third pages only, one inch margin back and front, top and bottom.

Envelopes must also be white and of proper size to receive the paper when folded as per regulation.

In all correspondence, if the subject-matter can be completed on one page, and no communications or papers are enclosed, a half sheet only will be used; but if there are enclosures, a whole sheet is to be used and the enclosures placed between the leaves, separately numbered and referred to accordingly. Both sides of a sheet must never be written upon.

An official communication must be folded twice, parallel with the ruling. It must be endorsed on the top of the back with name and rank of the writer, place or vessel, date, and brief statement of contents, as follows:

A_____ B_____,
Naval Cadet, U. S. Navy,
New York, N. Y., Aug. 1, 188_.
Application for duty on Asiatic station.

When on duty, all official communications must be forwarded through the commanding officer.

When off duty, they will be sent direct to the department.

When an officer is on sick leave in consequence of medical survey, he must report the state of his health to the department every fifteen days.

The uniform to be worn when reporting for duty at a naval station or on board of a vessel, and when a vessel is being placed in commission, is service dress, white gloves and sword.

THE MANNER OF REPORTING FOR DUTY ON BOARD SHIP.

He salutes the quarter-deck on reaching it. Reports to the officer of the deck that he has come on board to report for duty. The officer of the deck directs the orderly to announce him to the commanding officer. The latter directs that he be shown in the cabin. He then reports for duty, at the same time handing his orders to the commanding officer to be endorsed.

Immediately after reporting to the commanding officer, he shows his orders to the officer of the deck, who records them in the log book.

He must then report to the executive officer, who will assign him to a watch, division, boat, and station at "all hands."

He will then write to the department that he has reported for duty in obedience to its order. The letter should be written as per form B, and forwarded through his commanding officer. Forms A and B usually accompany all orders.

FIRST DUTIES AFTER REPORTING.

As soon as he has been assigned to a watch, division, &c., by the executive officer, he must make a neat *pocket* copy of the watch and quarter bills *complete*; a cleaning and fire bill for his own division; a boat bill for his boat, with stations for the crew for arming and equipping; a general station bill for "all hands" for that part of the ship where he is stationed. This enables him promptly to muster the men at their stations in his part of the ship at any evolution.

PAY ACCOUNTS AND TRAVELING EXPENSES.

On being detached from the Academy, get copy of pay accounts from the paymaster.

You are ordered to proceed to your home, and after

performing the journey you will be entitled to traveling expenses at the rate of eight cents a mile. In order to collect the same you must send your orders (a copy of them would not be sufficient) to the nearest navy pay agent, with a note requesting him to send you blanks to sign. There is a navy pay agent in each of the following places: Washington, Baltimore, Norfolk, Philadelphia, New York, Boston and San Francisco. He will forward you blanks in duplicate, which you sign and return to him. On their receipt he will send you a check for the amount due and return you your orders.

If while on "leave," or "waiting orders," you require your pay, you must send your accounts and a copy of your orders with all endorsements, certified to as follows:

I certify that this is a true copy.

_____, Naval Cadet.

to the paymaster of the nearest navy-yard, and request him to take up your accounts and send you a few blank receipts. When you wish a month's pay or the sum due you, sign the receipt in blank; the paymaster will fill it out and send you a check for the amount.

Immediately on receiving orders to duty, write to the paymaster having your accounts and request him to send them to you. Accompanying your letter must be a certified copy of your last order. After reporting on board the vessel to which you are ordered, and the commanding officer has endorsed your orders, you turn them and your accounts over to the paymaster, who takes your accounts up on his books and returns you your orders after he has had a copy of them made.

FORM A.

NEW YORK,
*Sept.*____, 188_.

Sir:-

I have the honor to acknowledge the receipt of the Bureau's order of the _____ for duty and will proceed in obedience thereto.

I am, very respectfully,

Your obedient servant,

Naval Cadet, U. S. Navy.

To

U. S. Navy,
Chief of the Bureau of Navigation and Office of Detail.

FORM B.

U.S.S. ____ 1st Rate.
MARE ISLAND NAVY YARD, CAL.
Sept. __, 188__.

SIR:-

I have the honor to inform the Bureau that I have, in
obedience to its order of the ____ reported to ____ for duty

I am, Sir, very respectfully,

Your obedient servant,

Naval Cadet, U. S. Navy,

To

U. S. Navy,
Chief of the Bureau of Navigation and Office of Detail.
Washington, D. C.

Forwarded by

CHAPTER XX.

PORT DRILLS WITH SAILS AND SPARS, AND MISCELLANEOUS PORT EVOLUTIONS.

The Trumpet.* The preceding chapters contain the prominent features of fitting out a ship for sea. We have now arrived at that part of the course where the young officer may be supposed to take charge of the deck; to conduct the usual port exercises.

The regularity and precision of military movements are not suited to a ship's decks, nor are the commands to be laid down with the exactness given in works on military tactics; but those officers who give their orders in accordance with the customs of the service, and in a tone and manner which command attention and inspire respect, will, all else being equal, get more work out of a ship's company than those who coin expressions for the occasion, and issue their orders as if obedience were doubtful or indifferent to them.

Commands. The commands are of three kinds: first, the *preparatory command*, which indicates what is to be done; as *Ready about! Get the starboard stun'-sails ready for setting! &c.* Second, the command of *caution*, which elicits immediate attention, and which is quickly followed by the third-the order of EXECUTION; as *Haul well taut! LET GO AND HAUL!* in tacking; *Set taut! HOIST AWAY!* when

setting studding-sails, hoisting boats, &c. *Stand by!* LET FALL! in loosing sail. (The first or cautionary order is printed in *italics*; the latter, or order of execution, in SMALL CAPITALS.)

When using the trumpet, place it so that the least concave arc of the mouth-piece may rest against the upper lip, while the greater is below and gives room for the play of the lower lip.

The commands of caution, *haul taut*, and *stand by*, are absolutely essential when working a number of men (as a watch, or *all hands*, for instance), for it is not possible with-

* It is customary at sea for the officer of the watch to carry a speaking-trumpet. This is done, not only that he may have an auxiliary, often necessary to the voice, but also that he may be readily distinguished as the one, for the time being, responsible for the safety of the ship.

In port the distinctive mark, sanctioned by a recent order, is a binocular, or the spy-glass.

324

out such commands to get them to exert themselves at the same instant, as they should do.

The preparatory order, if given deliberately, will be better understood, though it should not be uttered without due energy. The cautionary order should be sharp, quick, and full of energy, while that of execution should be distinct and emphatic.

PORT EXERCISES.

The following forms of port exercises are based upon the idea:

- 1st. That the drills are carried on under nearly the same conditions as in actual practice at sea;
- 2d. That "ready men" are superfluous;
- 3d. That the light yardmen start from the tops in working their yards, sails or topgallant masts. *

The exercises designated as COLOR EVOLUTIONS are those commonly performed at the hoisting or hauling down of colors; such as crossing the light yards or loosing sail in the morning, and sending down masts and yards at sunset.

When exercising in obedience to signal, the squadron orders will show the time allowed between the preparatory signal and signal of execution. That allowance is usually as follows: Crossing or sending down light yards, loosing or furling sail, the preparatory is hoisted six (6) minutes before the moment of execution, and the execution signal three (3) minutes before it is hauled down.

In sending up and down topgallant-masts and yards, the preparatory signal is made ten (10) minutes before, and the signal of execution is hoisted five (5) minutes before the time.

In bending sail the preparatory is hoisted fifteen (15) minutes before the time of execution; left up five (5) minutes and hauled down. The execution signal is hoisted three (3) minutes before the time of hauling down. **

In color evolutions, if not exercising in obedience to signal, give the order of execution at the *third* roll of the drum.

If obeying signals, always give the order of execution *the instant the execution signal starts from the truck*.

* The practice of sending seamen on the run from the sheer-pole to the cross-trees has frequently resulted in permanent injury to the individual. It is said to induce heart disease. The light yardmen should not only be sent into the tops in advance, but in sufficient time to allow them to regain their wind before going further.-S. B. L.

** In the Training Squadron, it has been customary, after hoisting a preparatory signal, to unbend the signal part and hoist the preparatory pennant, as a signal of execution. This is convenient and saves the bunting.

325

That all the squadron may be prepared to cross yards or loose sail at eight, or for any other manoeuvre at the hoisting of the colors, the flagship makes it a rule to designate seven bells (7:30 A.M.) by making a "time" signal at that hour. The squadron then have an opportunity of regulating their time by the flagship, and making such preparations for eight as may be necessary.

No exercise aloft is completed while a single straggler remains above the rail; the order to lay down from aloft should therefore not usually be given until *all* can obey it. There are one or two cases (as in crossing yards *and* loosing sail) where a certain number of men must remain aloft after the rest. In such instances, these men perform their duty promptly, lay down into the tops and remain there until piped down.

In all port evolutions, as soon as the crew are ordered to their stations, the men who are to go aloft place themselves *inboard* at the foot of the rigging ladders on their respective sides by watches. Men stationed on the head booms place themselves inboard of the head rail.

When about to lay aloft from the tops, the light yardmen place themselves at the foot of the topmast rigging outside of the tops. If going aloft to send down yards, they carry with them the bending ends of their respective tripping lines. Once bent, these are often left permanently aloft during drills, and lie in a loose coil at the foot of the respective masts.

When the men reach the yards, they should remain at the slings until ordered out. This rule is general.

Substitute signs for verbal orders whenever practicable. Commands can be frequently omitted with good effect. For example, in crossing yards or loosing sails, beating the "call" by the drum (or sounding it by bugle) is a sufficient signal for the men to lay aloft. So also the third roll indicates the moment of letting

fall, and dispenses with a certain amount of unnecessary noise.

Should the bugle be used at colors instead of the drum, give the orders "*sound the call*" and "*sound off.*"

At the *first note* of the bugle the light yardmen lay aloft from the tops, or the yards are swayed across, sails let fall, &c., as the case may be.

EXERCISES WITH SAILS.

General Directions. In all routine exercises with sails, as soon as the lower yardmen are on the lower yards, the two out-board men lay out quickly and unclamp the quarter-irons of the topmast stun'-sail booms. The two out-board men on the topsail-yards lay out to stop out the royal and topgallant yard-ropes to the topsail lifts in case

326

the light yards are in the rigging. These men should perform their duty promptly, and lay out and in together to the slings of the yards.

At the end of an exercise the same men on topsail-yards cast adrift the yard-ropes, and those on the lower yards remain out to clamp the boom-irons after the booms are lowered, then lay in quickly and down from aloft together.

In loosing, furling, bending, &c., the captain of the top, or man in charge at the slings of the yard, raises his right hand, as a signal to his officer on deck, the moment when the sail is ready for letting fall, as the case may be. No hailing from aloft is needed, and none should be tolerated.

If there are midshipmen in charge of the tops they should receive and transmit reports in a similar way, and the officers in charge of the respective masts on deck should also signify their readiness by signal of the hand to the executive officer.

For frequent port drills topsail-sheets may be singled and secured together with the clewlines by means of a short pendant fitted with sister-hooks connecting sheet and clewline to the clew of the sail.

The tacks and sheets may also be singled, or you may reeve one piece of half-worn rope, long enough for both tack and sheet, form a cuckold's neck in the middle, lead one end aft and the other forward. In the place of the regular clew-garnet reeve a rope through the clew-garnet block, half-hitch it to the cuckold-neck in the tack and sheet, leaving enough to splice in a pair of sister-hooks, which hook into the clew, thus connecting tack, sheet and clew-garnet to the sail.

These single tacks and sheets answer all purposes for drilling, and preserve the regular ones.

Use single ropes' ends for trysail sheets.

TO LOOSE SAIL TO THE BUNTLINES.

The preparatory signal being made, direct the boatswain to call:

LOOSE SAIL!

When the men are up:

*Man the clew jiggers and buntlines!**

This order shows How the sails are to be loosed. Let go and overhaul leechlines, reef tackles, brails and bowlines; also tacks, sheets, clew-garnets and clewlines, if hooked.

When preparatory signal is hauled down:

* If clew-jiggers are not used the clewlines should be kept fast and the buntlines hauled up square with the yard.

327

LOOSERS OF TOPGALLANT SAILS AND ROYALS IN THE TOPS

As execution signal is hoisted:

Beat the call! ALOFT SAIL LOOSERS!

Man the boom tricing-lines!

TRICE UP; LAY OUT; LOOSE

Keep fast topgallant and royal clewlines.

If the light yards are not aloft, the yard-ropes should be overhauled. The light sails are loosed in the rigging.

If ship has fires lighted, cast off forward stops of the covers of the main-sail and main-topsail, so that the sails will drop clear. Sail covers are taken off the fore and aft sails and head sails.

The officers having signalled their readiness: *Stand by!*

To the drummer: *Roll off!* At the third roll, or when execution signal leaves the truck:

LET FALL!

LAY IN! LAY DOWN FROM ALOFT!

The clew-jiggers and buntlines are hauled up alike, about two-thirds up the topmast. Topgallant-sails and royals hang down, their clews hauled up snug. The head sails are spread on the booms, heads of fore and aft sails hauled about half-way out.

The booms remain triced up.

Do not allow the leeches to be stopped in along the yards.

When loosing, if the sails are reefed, first let fall, shake out the reefs and then pull up the buntlines or haul out the bowlines, as the case may be.

If boats are to be lowered at colors, give the order in season:

Boat-keepers aft to lower your boats! and lower at the third roll. The falls should be hooked in their beackets and hauled taut, boat stoppers passed inboard and the boats hauled out to the booms, with their colors set, awnings spread, or sails loosed, as may the example of the flagship. In addition to the boat-keepers of the day, their reliefs lay aft to tend the boats' falls.

TO FURL SAIL.

(Loosed to the buntlines.)

The preparatory signal being made, direct the boatswain to call:

FURL SAIL!

If the light yards are across, on hauling down the preparatory signal:

TOPGALLANT AND ROYAL YARDMEN IN THE TOPS!

Have hands by the clew-jiggers and buntlines, man the buntwhips, spanker and trysail brails.

As execution signal is hoisted:

ALOFT TOPMEN! *Lower yardmen on the sheer pole!*

Topgallant and royal yardmen start at this order from the tops.

ALOFT LOWER YARDMEN! LAY OUT! The men all get in their places, the sails not to be handed until the execution signal is hauled down, then:

FURL AWAY!

The leeches are passed in rapidly, the sail gathered up snugly, and the gaskets passed square. When ready, the clew-jiggers and buntlines are eased down and buntwhips hauled up. Haul taut clew-lines and topsail sheets, clew-garnets, bowlines, leech-lines and brails. Put covers on fore and aft sails.

When ready aloft:

LAY IN! *Stand by the booms!*

DOWN BOOMS! LAY DOWN FROM ALOFT!

And then:

SQUARE YARDS!

Haul taut the rigging, square yards as described further on, clear up the decks and pipe down.

If the light yards are in the rigging, the sails are furled there-the light yardmen laying up in the lower rigging after the men have been sent aloft.

It will be noticed that the time of giving the orders to LAY ALOFT and to FURL differ from the instructions given in the signal book; but the method adopted is the best to insure the working together of other ships with the flagship. This is presumed to be the object of port drills in squadron.

If the drills are to be *competitive* in their character, an easy method of attaining the object is to hoist a general signal without preceding it by the preparatory.

Remarks on Furling. To furl a sail well, every cloth must be gathered up in handfuls, and each handful stowed. When this is done, let all hands lay hold of the skin; shake the slack canvas into it, and then toss the sail up, bringing the skin as a covering over the upper side of it. The bunt in this way will be low and round. The outside only will be wetted in the event of rain, and will dry without even being loosed.

High and Low Bunts. Low, or rolling bunts, require bunt-gaskets, and are tedious to stow, and secure snugly high. or French bunts require no gaskets, but secure to the topsail-tye by a becket and stop. Being larger, and more open abaft, the slack sail is more easily stowed in them than in low bunts; neither is any

time or labor lost about bunt-gaskets, a circumstance not to be overlooked, in competing with other vessels.

The look is a matter of taste; in foreign navies topsail yards are thought neatest, with first or second-reef earings

329

hailed partly out, but neither reef-points tied, nor bunt-gaskets on. In our service the reefs are never hauled out for furling and the bunt is peaked up by the bunt-jigger. Bunt-gaskets are used in addition, though objected to by many officers, as superfluous.

The proper place for the bunt-whip glut is two-thirds the depth of the first reef.

TO LOOSE SAIL TO A BOWLINE. *(Color Evolution.)*

Preparatory signal being made, the boatswain and his mates give the call:

LOOSE SAIL!

The men being up, *Lead along and man the bowlines and halliards!* This indicates the manner in which the sails are loosed.

As preparatory signal is hauled down:

LOOSERS OF TOPGALLANT SAILS AND ROYALS IN THE TOPS!

Let go and overhaul clew-jiggers, buntlines, leechlines, down-hauls, reef-tackles, brails, and royal and topgallant clew-lines. Lead out and man bowlines, head halliards and sheets and spanker and trysail out-hauls and sheets; but a turn is kept on the pins till the men are ready aloft.

On hoisting of execution signal:

Beat the call! **ALOFT SAIL LOOSERS!**

Man the boom-tricing lines! **TRICE UP!**

LAY OUT! LOOSE! *Toggle the bowlines!*

At this order the men in the bunt toggle the bowlines to the buntline toggles. Unhook tacks and sheets if fitted for exercise, also topsail sheets and clewlines; or, overhaul the latter roundly.

The sails being ready and gear manned:

Stand by!

To the drummer: *Roll of!*

At the third roll (or when execution signal leaves the truck):

LET FALL! HAUL OUT! HOIST AWAY!

LAY IN! LAY DOWN FROM ALOFT!

The men on deck run away with the bowlines and head halliards. The bowlines are hauled out square, the courses let fall so as to hang square, head sails hoisted, and sheets hauled aft, fore-and-aft sails hauled out, and trysail sheets and spanker out-haul hauled aft.

Overhaul roundly the topgallant and royal clew-lines.

In foreign navies the topgallant and royal sheets are hauled taut-the plan is not generally followed in our own service. The booms remain traced up.

Observe remarks about reefed sails under **LOOSING TO THE BUNTLINES.**

330

TO FURL SAIL FROM A BOWLINE.

The preparatory signal being made, call:

FURL SAIL!

When preparatory signal is hauled down,

TOPGALLANT AND ROYAL YARDMEN IN THE TOPS!

Man the clew-jiggers and buntlines; head down hauls; spanker and trysail brails!

Man the above-named gear, also the leechlines, topgallant and royal clew-lines, and spanker and trysail head down hauls and clew ropes. Tend the head sheets and halliards, trysail and spanker outhauls and top bowlines.

Signal of execution being hoisted:

ALOFT TOPMEN! *Lower yardmen on the sheer pole!*

ALOFT LOWER YARDMEN!

The topgallant and royal yardmen start from the tops as the topmen start from the deck.

Haul taut! SHORTEN SAIL!

The men on deck let go the gear tended, and haul on the gear manned.

LAY OUT!

The men take their stations on the yards.

As the signal of execution is hauled down

FURL AWAY!

The bunt-jiggers are hauled taut as soon as practicable and bunt roused up, top bowlines untoggled and hitched to the neck of the topsail tye-blocks, bights overhauled down and stopped to the forward part of the top. Unhook clew-jiggers and hook them in the top, hook clew-lines and sheets and tacks, if unhooked before loosing.

The head and fore-and-aft sails are stowed and covers put on.

When ready:

LAY IN!

Stand by the booms! DOWN BOOMS!

LAY DOWN FROM ALOFT!

Then square yards, clear up the decks, and pipe down.

HAVING LOOSED TO A BOWLINE TO SHORTEN SAIL.

If the sails are sufficiently dry, it is usual to furl at seven bells in the forenoon watch; before furling, however, it may become necessary to shorten sail. When a fresh breeze springs up, a ship with so much canvas gets uneasy at her anchor; or, there may be indications of rain. For whatever reason, if it becomes desirable, call

SHORTEN SAIL!

And when the people are up,

ALOFT TOP-GALLANT AND ROYAL YARDMEN!

Man the clew-jiggers and buntlines, head down-hauls! spanker and trysail brails!

Man and tend the gear named under FURLING FROM A BOWLINE.

Haul taut! SHORTEN SAIL!

FURL THE TOPGALLANT SAILS AND ROYALS! STOW THE FLYING JIB!

Furling the light sails before the rest is a common practice, particularly when short handed. It is entirely optional, however, and if preferred to furl all together, the orders relating to them will be omitted. The same applies to them when in the rigging. At the order, SHORTEN SAIL, the bowlines and halliards are let go, the head sails are hauled close down, the square sails are hauled up by the clew-jiggers and buntlines, and the trysails and spanker brailed up.

TO MEND SAIL.

If the sails have been badly furled, or for any other reason require restowing, the preparatory signal will be made. Call:

MEND SAIL!

When the men are up, as the preparatory signal is hauled down:

LOOSERS OF THE TOPGALLANT-SAILS AND ROYALS IN THE TOPS!

On hoisting of execution signal:

ALOFT SAIL LOOSERS!

Man the boom tricing-lines!

TRICE UP! LAY OUT!

On hauling down of execution signal,

MEND THE FURL!

The gaskets are cast off and the sails are restowed, with a fresh skin outside, the gaskets secured afresh.

When completed,

LAY IN! *Stand by the booms!*

DOWN BOOMS! LAY DOWN FROM ALOFT!

If the sails are very badly furled, send aloft the FURLERS instead of the losers, and LET FALL! then FURL AWAY!

The clew-jiggers and buntlines are usually run up a few feet while mending the furl, lowering as the bunt is stowed.

BENDING SAIL.

In the chapter on SAILS will be found a description of the method of bending sails *made up for stowage*, as received from the Navy Yard. In practice, however, square

332

sails should be kept on board ship (if the sail-room space permits) ready for bending, *made up as furled*.

Preparations for Bending. All square sails are fitted with gaskets, stitched on the head at equal distances.

Seize the sail straps to the heads of all three of the topsails at the middle eyelet holes; let them always remain there, and when using them, after the sail is rolled up, carry the foremost leg round the after one, and seize its bight to its own parts. Topmen are very apt to cut this seizing too soon; but by having the strap fast to the head, their mistake may be partly remedied by a pull on the sail burton, which is always hooked to the after leg.

Topsails. Haul the head of the topsail along the deck, after side downward; gather all the slack canvas back from the head; lay the second reef-band along the head, and haul this and the head taut fore and aft by the earings. Bring the leeches as far as the reef-tackle cringles along the head; knot the fourth reef-earring into the third reef-crinkle, and the third into the second; carry the clews into the quarters about six feet over the head; bring the buntline toggles about a foot over the head between the clews: coil all the remainder of the roping, so as not to ride, leaving the bowline cringles out; face the foot and gather up; then face the head and roll up, pass the gaskets taut; stop the clews up abaft the head, after having passed them over the fore part of the bunt; seize the strap; hook the sail tackle; knot the second reef-earring into the first reef-crinkle, the first into the head, unless bull-earings are used on the yards; and secure the head-earings along the top of the sail on each side.

Fig. 373 and Fig. 375, Plate 71, show the mode of passing sail straps. The latter with single legs is preferable for permanent straps, as it is easier to stow away aloft. Each leg should be seized to the head of the sail.

Courses. Place, open out and stretch the heads of the courses taut along the deck well amidships, after sides down; the foresail on the starboard side of the forecastle, port head-earring well forward; the mainsail

in the port gangway, bunt abreast the mainmast, starboard head-earring forward; gather the sail back from the head, making a smooth surface; stop the first reef-cringles to those of the head-earring; pass the leeches taut until within six feet of the clews, leaving the leechline cringles out. If the leeches are too short to allow the clews to reach to the bunt by taking the first reef-cringle to the head-earring cringle, a bending cringle must be worked on the leech about a foot under the head-earring cringle; in which case, make the sail up without seizing the first reef-cringle to the head-earring. (The yard-arm jiggers will hook to the bending cringle.) Haul the clews and the remainder of the leeches out clear of

333

the head of the sail; carry the foot-rope up to the head, leaving the buntline toggles out clear about the middle of the sail; gather sufficient of the slack sail to make a long low bunt; the men cross over, face the head, roll up taut and pass the gaskets; coil and stop the earings to head of the sail; take the clews over, around and under the sail, and stop them to the head of the sail; place marks on the head of sails, at distances from the middle equal to the distance from the slings to the leechline blocks on the yards, so that the leechlines will haul the sail up fair in bending.

In bending courses and topsails together, the topsails are placed fore and aft forward of their respective masts, fore and mizzen on the port side, main on the starboard side. The courses are athwartships under their respective yards.

Gear for Bending Topsails. The sail burton, hooked before the sail leaves the deck; yard-arm jiggers, hooked when sail is aloft.

1st. The sail burton is the top burton of the side on which the topsail is swayed aloft. The upper block is hooked into a strap at the crotch of the topmast-stay; the lower block and fall are sent on deck forward of all. To the hook of the lower block secure a tail-block, through which reeve the fall, leading it thence through a snatch-block hooked to a bolt well forward. This arrangement guys the sail clear as it goes aloft. The fall leads *aft* for the fore and main, *forward* for the mizzen. The lower block of the sail burton hooks into the sail strap. Fig. 266, Plate 35, also Figs. 373 and 375, Plate 71.

2d. The yard-arm jiggers-the upper blocks hooked to straps on the pacific-irons of the topsail-yards, the lower blocks hooked at the forward side of the top rim, ready for hooking into the second reef-cringles of the topsail as soon as they are high enough.

The topsail reef-tackles are used for this purpose, if practicable. Should their lead not permit of it, other jiggers must be substituted.

Gear for Bending Courses. Buntlines, leechlines, and yard-arm jiggers; all bent (or hooked) before the sail leaves the deck.

Toggle the buntlines to the sail; pass them abaft, under and up forward around the bunt of the sail, around their standing parts, and stop to their own parts.

Leechlines are clinched to their cringles and stopped to their marks at the head of the sail.

The yard-arm jiggers are the clew-jiggers; upper blocks carried out to straps on the pacific-irons, lower blocks hooking to the *first* reef-crangle, head-earings hitched to standing parts of the jiggers. If regular reef-tackles are fitted, use them for yardarm-jiggers.

Gear for the Jib. The down-haul and halliards, and a

334

strap around the body of the sail to which the halliards are hooked and down-haul bent.

Gear for the Spanker. If the gaff is not lowered, a whip from under the top to hook into a strap around the head of the sail. The detail does not differ from the description of bending spanker given under SAILS.

The courses, topsails, jib and spanker are generally bent together. To perform the evolution, at the preparatory signal the boatswain will be ordered to call "BEND SAIL."

Losers of topsails and courses, and men stationed at boom tricing-lines, stand by to lay aloft.

The balance of the men in each part of the ship go below and rouse up the sails, or if the hatches open fair to the sail-room, clear these hatches away to rouse up the sails from below with the spare main-top burton, overhauled down abaft the top, or with the trysail vang.

On hauling down of preparatory:

ALOFT SAIL LOOSERS! *Losers of courses* go on the lower yards, overhaul lower blocks of clew-jiggers to the deck, stand by to carry out upper blocks, cast adrift bunt-whips, overhaul buntlines and leechlines to the deck.

Losers of topsails; shift upper block of sail-burton to strap on stay, send down lower block and fall, forward; hook lower blocks of yardarm-jiggers to top rim, stand by to carry out upper ones, secure back cloths, unless these are sewn on the sail, cast adrift buntlines and bunt-jiggers.

Losers of jib lay out and bring in jib halliards and end of down-haul, place centipedes.

On deck, let go and lead out sail-burtons, buntlines, leechlines and jib down-haul, lower spanker gaff and prepare sails for going aloft as before directed.

CARRY OUT YARDARM-JIGGERS! The men lay out with the upper blocks and hook them, unclamp the booms, and if the light yards are in the rigging stop their yard-ropes out of the way.

LAY IN ON THE YARDS! The men aloft lay in and stand by to receive the sail!

MAN THE SAIL-BURTONS AND BUNTLINES; JIB-HALLIARDS!

As the signal of execution is hoisted:

Haul taut! SWAY ALOFT! Pull up on the jib-halliards, raising jib well clear of the rail; run away with the sail burtons and jib down-haul. When the bunt of the topsail reaches the lower yard, start up the courses.

The yardarm-jiggers and leechlines should not be touched, the sails hanging up and down the masts by the burtons and buntlines. When high enough, with the second reef cringle of the top-sails above the tops and the bunt of the course abreast of its yard:

A turn with the burtons! The men in the tops slew turns. out of the sails and hook the yardarm-jiggers.

335

Stand by to lay aloft! and when ready:

ALOFT TOPMEN! *Lower yardmen on the sheer pole!*

ALOFT LOWER YARDMEN!

Man the boom tricing-lines, yardarm-jiggers and leech-lines!

TRICE UP! HAUL OUT! LAY OUT! AND BRING TO! as the signal starts from the truck.

At the order HAUL OUT:

Top-sails are hauled out taut along the yard by the yardarm-jiggers, the burtons slacked until the middle bending hole is abreast the jackstay.

Courses are hauled out by the yardarm-jiggers *and* leechlines; jib is swayed out by the down-haul.

At the order "BRING TO:

1st. Secure the midship stop and two robands of a side.*

2d. Pass two turns of the head-earings through their respective eye-bolts and four turns through the thimble of the backer and head-earring cringle.

3d. Secure the balance of the robands.

4th. Cut adrift the buntlines, leechlines and sail-strap, and haul the former up clear.

Let go on deck and cast off the yardarm-jiggers, stand by to carry in their upper blocks, hook the topsail reef-tackles to their proper cringles; hook the reef pendants to the courses; hook and haul taut buntwhips, toggle top-bowlines and topsail buntlines; hook sheets and clew-lines to the clews; shackle tacks and

sheets and hook clew-garnets to clews of courses; shift upper block of sail-burton to masthead pendant; round up the burton on deck, shift its lower block and fall abaft the topsail yard to its place.

The jib is swayed out by its down-haul at the order "sway aloft," tending the halliards; land the tack on the boom, hook the tack, shackle the sheets, shift the down-haul and halliards to their proper places, take off sail-strap, hoist the sail as the hanks are being secured. Then haul down and stow it, and put the cover on, unless sail is to be made.

While the sails are being bent, the signal will probably be made, MAKE SAIL! Order:

Stand by to let fall: Man the topsail sheets and halliards!

* A *metallic* roband consists of a galvanized iron hook which hooks upon the bending jackstay and which has, on its forward side, a projecting lug, like a button. The head of this button is pierced with a thwartship hole. In bending, the roband eyelet on the sail is put over the head of the lug, and when all the robands have been attached, a piece of ratline stuff is rove through the heads of all the lugs, forward of the sail, as a preventer. The hooks traverse on the jackstay, so that the head of the sail may be stretched at any time by hauling on the head earings without unbending the sail. Fitted to the sails of the Trenton and Galena, and in many merchant ships.

336

The sail being bent and loosed:

Stand by! LET FALL!

SHEET HOME!

LAY IN! *Stand by the booms!*

DOWN BOOMS! LAY DOWN FROM ALOFT!

and proceed as in MAKING SAIL.

It is always advisable to proceed as above in bending new sails or preparing for sea, to see if the gear is properly bent and the sail sets well.

Should there be no signal for making sail after bending, then, the sails being bent and the furl "mended," as necessary, order:

LAY IN! *Stand by the booms!*

DOWN BOOMS! LAY DOWN FROM ALOFT!

The booms are lowered and clamped, and all the men lay down from aloft, without straggling.

To Bend the Light Sails. The light sails are generally bent immediately after the others, to do which, give the order:

Stand by to bend the light sails! At this the yards are prepared for getting out of the rigging, and the flying-jib for going out, on the port side, owing to the lead of the downhaul; when ready

Man the topgallant and royal-yard ropes! flying jib halliards!

Haul taut! SWAY OUT OF THE CHAINS! Pull up on the flying-jib halliards, and then haul out the flying-jib by the down-haul at the same time that the yards are swayed inboard. The yards being clear of the hammock nettings-

LOWER AWAY TOGETHER!

The sails are bent and neatly furled, with the clews in; the yard-ropes hooked and manned; the flying-jib being bent at the same time. Then, order:

Man the yard-ropes!

Haul taut! SWAY OUT TOGETHER!

When placed in the rigging the bunts of the light sails should be slewed outboard.

On board large ships, it is convenient to get these yards in and out of the rigging with the lower clew-jiggers.

TO UNBEND SAIL.

(Port Routine-Light Yards in the Rigging.)

At preparatory signal, call:

UNBEND SAIL!

On hoisting of execution signal:

ALOFT SAIL LOOSERS!

The losers of courses, topsails, jib, flying-jib, spanker and trysails go to their stations.

Man the boom tricing-lines!

TRICE UP! LAY OUT AND UNBEND!

Cast gaskets adrift from the yard and pass them around sail.

On Topsail-Yard. Cast off midship stop, unhook the bunt-whip and secure it to the tye, secure the buntlines around the body of the sail, take the bight of the buntline on the side opposite to the one on which the sail is lowered, and stop this bight snugly to the head-earring cringle. Hitch bowlines to tyes, unhook clews and stop them to the buntlines, unhook reef-tackles and pass the lower blocks into the top; pass slip stops if necessary to hold up the sail, single the head-earings for easing away, cut robands.

Make similar preparations on the lower yards, except that the leechlines are secured to the slings and the reef. pendants stopped along the yard to the jack-stay.

Head Sails. Cast adrift sail covers, secure them with the sails, unshackle sheets, stopping them to the stays, cap or wythe, as the case may be, pass stops around the sails, cast off gaskets, unhook the tacks, hook the halliards and secure the down-haul to a strap around the body of the sail, cut adrift the hanks, or untoggle them.

Trysails, &c. Let the covers fall on deck, hook whip under top and to strap around head of sail, unbend head out-haul and down-haul and throat lashing, cut adrift stops on hoops of gaff and mast, cast off tack lashing.

Man the head halliards, tend buntlines, trysail whips, brails and clew-rope and head down-hauls.

Stand by!

When execution signal is hauled down-

EASE AWAY!

Ease away the earings, let go the slip stops on the yards, run away with the topsail buntline of the opposite side, tricing up the upper earing of the topsail. Run the head sails up by their halliards some ten or twelve feet.

LOWER TOGETHER!

The men aloft see the yards clear of stops and yarns, and if so ordered strip them of reefing becketts and back cloths, unless the latter are stitched to the sail. Ease in the head sails by their down-hauls.

When ready

LAY IN! *Stand by the booms!*

DOWN BOOMS! LAY DOWN FROM ALOFT!

Then square yards, haul taut the gear and pipe down.

If the light yards are in the rigging, *sails bent*, the sails may be unbent in the rigging, but it is decidedly more shipshape to sway out of the chains and unbend inboard after the evolution aloft has been performed.

If the light yards are aloft, sails bent, see UNBEND SAIL AND SEND DOWN TOPGALLANT AND ROYAL YARDS.

22

338

NOTE. A handsome method for unbending topsails in port is to reeve a light line from deck, through a tail-block on the lift, at the side upon which the topsail is to be lowered, taking the end along the yard and bending it to the opposite head-earring. At order "ease away" keep fast the head-earring on the lowering side, ease away the other earring, hauling on the light line on deck and rousing over one head-earring toward the other.

At order "lower away," lower the buntlines, keep fast the light line and head-earring for a moment, to fully decide the sail's lowering well clear of the lower stay, top rim, lower braces, &c., then lower rapidly together.

TO MAKE SAIL.

Preparatory signal will be hoisted ten (10) minutes beforehand.

Direct boatswain to call:

MAKE SAIL!

As soon as the signal is made out, get the lower booms alongside and unhook topping-lifts; cast adrift ridge-rope and top up spanker boom. The crew go to their stations as in "loosing sails." In addition, hook leaders and snatch topsail halliards and lead the halliards and sheets out; lead jib halliards through a leader hooked forward, and close amidships, clear of the topsail halliards; lead out spanker outhaul; lay down on deck, tacks, sheets, buntlines, clew-lines, clew-garnets, leechlines, reef-tackles, down-hauls, brails, braces, lifts and bowlines.

Signal of execution will be hoisted three (3) minutes beforehand.

LOOSERS OF THE TOPGALLANT-SAILS AND ROYALS IN THE TOPS!

Will be given as soon as the signal of execution reaches the truck.

As the signal is hauled down:

ALOFT SAIL LOOSERS!

Man the topsail sheets and halliards; jib halliards and spanker outhaul!

The starboard fore and port main topsail halliards are manned by a few hands, and a good strain is kept upon them, while the topsail yards are being hoisted.

LAY OUT! LOOSE!

Will be given as soon as the men reach the yards. Keep the sails well up on the yards and on the head "booms; overhaul topsail buntlines, fore and main leechlines and bunt whips; the men on deck let go topsail buntlines and reef-tackles; tend bunt whips and topsail clewlines, down-hauls. and brails.

Stand by!

339

LET FALL! SHEET HOME! LAY IN! LAY DOWN FROM ALOFT!

HOIST THE JIB! HAUL OUT THE SPANKER!

Tend the braces!

HOIST AWAY THE TOPSAILS!

Will be given when all ready aloft and about decks. Make a short pause after the cautionary order "stand by." The remaining parts of the order save the last, are given in quick succession. The jib is hoisted and the spanker hauled out. The order to "hoist the topsails" is given as soon as the men are off the yards. The loosers, except those stationed aloft to light up gear, rapidly lay down from aloft and in from off the head booms, and clap on their respective topsail halliards. The clewlines are eased down, to prevent accident to the men on the lower yards. The topsail braces are let go and tended. The mizzen topsail is hoisted by the men stationed on the halliards; the men on the fore and main topsail halliards walk respectively aft and forward, cross the deck abaft the engine-room hatch and forecastle, and clap on the main and fore topsail halliards.

WELL THE MIZZEN TOPSAIL! BELAY THE FORE TOPSAIL HALLIARDS! BELAY THE MAIN TOPSAIL HALLIARDS!

Will be given when the leeches of the respective topsails are taut. The topsail halliards are belayed, unsnatched, and coiled down clear for running.

Topgallant sheets and halliards!

Will be given as soon as the topsail halliards are belayed. The gear will be manned, and the topgallant clew-lines, buntlines and braces tended.

SHEET HOME AND HOIST AWAY THE TOPGALLANT SAILS!

The topgallant sheets are hauled home; the sails hoisted to a taut leech; the braces are let go and tended. When the sails are hoisted and the sheets home:

Royal sheets and halliards! Flying jib halliards!

Overhaul down-haul and royal clewlines; tend royal braces.

SHEET HOME, HOIST AWAY! hauling aft the port (starboard) flying jib sheet.

The halliards and sheets are belayed and coiled down clear for running.

Man the port (starboard) head and main, and starboard (port) crossjack braces:

Fore and main tacks and sheets: let go and overhaul the lower lifts: Clear away the bowlines: will be given as soon as the royals and flying jib are set.

Haul taut; BRACE UP: clear away the rigging: HAUL ABOARD.

A short pause is made after the cautionary order. The yards are braced sharp up on the starboard (port) tack, and the courses set as when "by the wind."

340

Haul taut the weather lifts: steady out the bowlines: LAY DOWN FROM ALOFT:

Will be given as soon as the previous order has been executed. The lifts and bowlines are hauled well taut: everybody will lay down from aloft. *The men on deck will see everything clear for shortening sail.*

A common error in this evolution is to man the topsail sheets heavily, and ensure getting the sheets home before attention is paid to hoisting rapidly. This makes heavy work for the sheets, sawing the foot of the sail across the stay. It is better to put all but a few hands on the halliards till the sail is about two-thirds up, then if the sheets are not home, break off hands from the halliards to the sheets as required.

TO SHORTEN SAIL.

(Ship under all plain sail by the wind.)

Preparatory signal will be hoisted ten (10) minutes before clewing up. Direct the boatswain to call:

SHORTEN SAIL!

When the preparatory signal is hauled down, the men stationed in the tops to light up rigging and to lay out on the lower yards to attend at the topsail sheets, are sent aloft: the former will go to the topmast heads and overhaul down the clew-jiggers forward of the topsails, and the latter to the quarters of the lower yards, and stand by to carry out the lower blocks. The men on deck lead out the royal and topgallant braces, clew-lines, topgallant buntlines, flying jib down-haul, and fore and main clew-garnets, buntlines and leechlines.

Signal of execution will be hoisted three (3) minutes before clewing up.

Man the royal and topgallant clewlines: flying jib down-haul: fore and main clew-garnets and buntlines!

Will be given when the signal reaches the truck.

The fore and main clew-garnets, buntlines and leech-lines; royal and topgallant clewlines, weather braces, topgallant buntlines and flying jib downhaul are manned. Have hands by fore and main tacks and sheets, royal and topgallant sheets and halliards, lee braces and flying jib halliards. The men on the lower yards lay out and hook the topsail clew-jiggers.

Haul taut: SHORTEN SAIL!

will be given when the signal of execution is hauled down; a short pause is made after the cautionary order. The gear tended is let go, the lee royal and top-gallant braces are let go and belayed at their square marks; run away with the gear manned. The courses are hauled up: the royals and

341

topgallant sails are clewed up, the yards clewed down, and the weather-braces rounded in and belayed at their square marks; the flying jib is hauled down. The tacks, sheets and halliards are hauled taut and belayed: the leechlines, buntlines, clew-garnets, clewlines, braces and down-haul are coiled down.

Man the topsail clew jiggers and buntlines; jib down-haul: spanker brails!

Tend the topsail sheets, jib halliards, spanker outhaul and top bowlines.

Haul taut! SHORTEN SAIL!

The jib is hauled down and spanker brailed up; the bowlines are let go; the men run away with the topsail clew-jiggers and buntlines, until up to their marks. The clew-jiggers and buntlines are belayed and coiled down.

Man the weather braces! Stand by the topsail halliards! will be given as soon as the topsails are clewed up. The men jump to the weather lower and topsail braces, and lower lifts, and stand by to lower away on the topsail halliards.

The men on the lower yards, unclamp the studding sail booms, and lay in to the slings of the yard.

Settle away the topsail halliards! SQUARE AWAY!

Will be given as soon as the gear is manned. The topsail halliards are lowered roundly, until the topsail yards are down, when haul them taut, belay and coil them down. The braces are hauled in and the lower lifts down and belayed at their square marks, and coiled down.

FURL SAIL!

Will be given when the "signal of execution" for that evolution is hoisted. This order will be repeated by the boatswain and his mates, and executed as per furling sails when loosed to the buntlines. But after "ALOFT LOWER YARDMEN, add: *Man the boom tricing lines!* TRICE UP!

If the clew-jiggers are already hooked (or not used) the men stationed on the lower yardarms are not sent aloft till execution signal is hoisted.

TO SQUARE YARDS.

The yards are generally squared daily in port at seven bells in the morning watch, and also after any exercise aloft.

Order:

SQUARE YARDS! *Call away the _____ cutter!*

Mastmen lay down braces and falls of lower lifts. The square yardmen stand by to lay aloft.

The boatswain should first assure himself that the slings of the light yards are *down in their places*, and also that the masts are properly lined; particularly the lofty spars

342

which are apt to get out. Then commencing forward, the boatswain squares the yards by the braces, lining them by the break of the forecastle, coamings of hatches, &c., as may be most convenient.

The yards being squared by the braces, and the cutter manned at the port gangway, as the boatswain leaves the side order:

ALOFT SQUARE YARDMEN!

Get the lift-jiggers on!

The square yardmen stand by to come up the racking seizings and tend the lifts. The boatswain pulls

ahead of the ship, the chief boatswain's mate lays out to the flying jibboom end, and repeats such orders as are issued by the boatswain. The boatswain's mates place themselves at each mast, and carry out the orders received.

When the yards are square by the lifts and braces, the boatswain's mates go to the sides or poop to repeat such orders as the boatswain may give in pulling around the ship.

The boatswain carries with him a white, a red, and a blue flag, each bent to a short staff, to denote respectively yards on the fore, main, and mizzen masts. He faces the ship. A flag held in the right hand signifies yards to starboard; in the left hand, yards to port.

For lower yards the flag is held depressed at an angle of 45 °.

For topsail yards it is held horizontal.

For topgallant yards it is elevated 45°, and for *royal yards* held vertically over the head.

Signal for topping up *lower booms* with empty hand.

The lower yards are squared first, beginning with the fore, then the upper yards. In squaring the topsail-yards by the lifts the laniards are come up to two or three turns, and the jiggers hooked and hauled taut—that when topping up on one the other may be eased by the jigger steadily. When *belay* is piped clap on a heavy racking of spun-yarn.

In squaring *light yards* by the lifts, *tend the braces*, or the yards will get bowed. The boatswain's mate at the mast must see that in checking a light brace the yard is kept square by the braces. Sometimes a hand must be sell aloft to ride a light yard down.

Having squared the yards, the boatswain pulls around the ship, directing all gear to be hauled taut, and boats and lower booms squared. The stun'-sail booms should be rigged out alike and heels square, gaffs peaked up alike, the head booms properly stayed (usually straight, or with a slight *downward* curve—never with an upward curve). Harbor clothes-lines should be on a level from fore to mizzen mast, whips hauled up alike.

See that no ropes' ends are overboard or hanging from

the tops; windsails squared; hammocks leveled; clew-lines chock up; and that the tops, chains, &c., look neat.

When satisfied, the boatswain returns on board and reports to the officer of the deck:

The yards are square and the rigging hauled taut.

And the decks being cleared up, he is directed to

PIPE DOWN!

At which the square yardmen lay down from aloft together.

HANDLING LIGHT YARDS.

For description of fittings on the yards see RIGGING SHIP.

Tripping Lines. The hauling end reeves through a small tail-block. In port the other end is kept permanently bent to the snorter, and when the yard goes aloft it is toggled at the slings. It serves in this way to guy the yards clear when going aloft.

In sending down the toggle is slipped at the *first* roll. *

Yard Ropes. The after or hauling part of the yard-rope is kept coiled down in the top, and is paid down on deck and rove through a snatch-block hooked to the deck, abaft the mast, when prepared for use.

When not crossed the yards are kept in the lower rigging, the topgallant yard on one side and the royal yard on the other, their lower ends resting in a becket or stirrup, and the upper end secured to the forward shroud.

The fore and mizzen topgallant yards are kept on the port side, the main on the starboard.

When the light yards are crossed the gear should always be bent and clear for making sail. The "gear" comprehends topgallant and royal sheets and clewlines, topgallant buntline and bunt-whip.

Bull-Rope for topgallant yards. A small bull's-eye is secured to the forward swifter, at the height of the upper topgallant yard-arm, when the yard is in the rigging.

The bull-rope has a good-sized eye formed in its upper end, and a small whip from the pin-rail tailed on to its lower end; or it may reeve through a leader at the rail, then through the bull's-eye, with the standing part seized to the swifter.

The eye (or bight) of the bull-rope is overhauled to the lower yard, and there slipped over the upper yard-arm as the yard comes down, in order to trice it into the rigging. When in the rigging the upper yard-arm is secured by a grab lashing and the eye of the bull-rope hove off and brought down to the pin-rail, or the

bight hauled taut.

* See these tripping lines coiled down clear when exercising at making sail with light yards aloft.

344

Gear Stops are placed on each side of the topmast head, secured at the eyes of the topmast rigging. They are used to stop in the topgallant sheets, topgallant clewline, royal sheet and clewline, and eye of the topgallant lift and brace. Some ships use also *checking lines*, which are rove through bull's-eyes on either side of the topmast cross-trees and jack, and led into the tops. They are toggled around the eyes of the lifts and braces the moment these are clear of the yard-arms, and haul them in snug to their respective mast-heads. Rarely used except in port.

Royal Sheets are much more easily handled when snatched in cleats screwed on the after side of the topgallant yard-arms, and fitted with rollers, the cleat taking the place of the sheave in the topgallant yard. This plan is adapted both for port drills and use at sea, and is frequently followed.

Topgallant Stun'-sail Jewel Blocks. The eyes of the jewel-blocks are marled to the eyes of the topgallant lifts and braces.

Sheets and Clewlines of topgallant sails, also of royals, are made fast together, so that they may be bent with one motion.

Quarter Blocks. When unhooked from the yards, the topgallant quarter-blocks hook to the topmast cap, royal quarter-blocks to becket at the eyes of the topgallant rigging. Topgallant buntline and bunt-whip stop to the forward edge of the topmast cap.

Individual stations, showing number of men aloft:

SENDING UP YARDS

In top-To tend lifts, send down yard ropes and put on topgallant halliards. *

SENDING DOWN YARDS.

In top-To tend lifts and checking lines, send down yard ropes, take off top, gallant halliards.

The captains of tops and two men.

TOPGALLANT YARDS.

On topmast cap-Rig upper yard-arm, tend lizard, pass parrel, bend gear

On topmast cap-Unbend gear, stop out yard rope, cast off parrel, draw toggle of tripping line.

One man.

On topmast crosstrees-Over-haul lower lift and brace down, assist with parrel and gear

On topmast crosstrees-Bear off yard, unbend gear, assist man on cap.

One man.

On topsail yard-Rig lower yard-arm, then in top to lower lift *On topsail yard*-To bear off.

One man (from the top).

In topmast rigging-To over-haul down lower lift, then in top *In the top*-At checking lines, &c.

One man.

In lower rigging-Clear away the upper yard-arm, then to yard rope *On lower yard*-With eye of bull rope to heave over the upper yard-arm.

One man,
with additional assistance in the chains, as needed.

ROYAL YARDS.

SENDING UP YARDS

At jack-To rig upper yard-arm, tend lizard, pass parrel, bend gear

One man.

On topmast cross-trees-Rig lower yard-arm, bear off yard, bend gear

One man.

In lower rigging-Clear away yard, then to yard rope *In lower rigging*-Receive yard and secure it.

One man.

SENDING DOWN YARDS.

At jack-Unbend gear, stop out yard rope, cast off parrel, draw toggle of tripping line.

On topmast cross-trees-Unbend gear, light up yard rope, bear off yard, &c.

NOTE.-The stations given above are those adopted in the Navy Station bill. But a common practice is to put on both royal lifts at the jack, the upper topgallant lift, &c., at the cap and the lower one at, or just below, the cross-trees. In each case the upper lift and brace is put on first, the yard then swayed chock up, and the lower lift put on. This avoids overhauling down the lower lifts and braces. Checking lines must be rove accordingly, if used.

Lizard. In lieu of the lizard described in RIGGING SHIP, a hook traveling on the yard rope, has been used on board many ships. Fig. 473.

TO CROSS TOPGALLANT AND ROYAL YARDS.

(Color evolution.)

Preparatory signal being made, give the order to call:

UP TOPGALLANT AND ROYAL YARDS!

346

The crew having gained their stations, when the preparatory is hauled down,

TOPGALLANT AND ROYAL YARDMEN IN THE TOPS!

Send down the yard ropes!

Lead them out and man them. When execution signal is hoisted:

Beat the call!

This is the signal for the light yardmen to lay aloft from the tops. (If not at colors substitute the order ALOFT TOP-GALLANT AND ROYAL YARDMEN!)

Set taut! SWAY OUT OF THE CHAINS!

At this order, the upper topgallant yard-arm is carried clear of the top rim, the royal yard clear of the cross-trees.

When the yards are steady, and the men shortened in on their holds

SWAY ALOFT! When high enough for rigging the yardarms, the order is given

High enough! And when rigged-

SWAY HIGHER!

When ready for crossing-

Tend the lifts and braces!

Stand by!

To drummer: *Roll off!* and at the third roll, or as signal is hauled down:

SWAY ACROSS!! BEND THE GEAR!

The yards are squared by lifts and braces.

HAUL UP THE YARD ROPES!*

When they are hauled up and neatly coiled away in the tops. Then:

LAY DOWN FROM ALOFT!

When topgallant yards are across, the jack must be hoisted and hauled down with the colors.

If a yard has been crossed with a lift and brace foul, stop out the yard rope for a preventer lift lay out-take off the lift and brace and clear it, then cast off the stop and haul taut the yard rope.

TO SEND DOWN TOPGALLANT AND ROYAL YARDS.

(Color evolution.)

At five (5) minutes of sundown preparatory signal will be made. Order the boatswain to call:

DOWN TOPGALLANT AND ROYAL YARDS! when preparatory is hauled down,

TOPGALLANT AND ROYAL YARDMEN IN THE TOPS

Send down the yard-ropes!

* Not usually given, if drills are to be continued.

347

At the hoisting of the execution signal three (3) minutes before sundown:

Beat the call! The light yardmen lay aloft from the tops. (If not at colors, substitute the order: **ALOFT TOP-GALLANT AND ROYAL YARDMEN!**)

Snatch and lead along the yard ropes, man them (but not too strongly), take them near a cavil ready to catch a turn for lowering, which should be done by a careful hand. The tail blocks of the tripping lines are secured to eye-bolts well forward of the mast and at the side. Yard ropes and tripping lines are toggled in to the slings of the yards by a toggle to be drawn at the *first* roll.

Man the yard-ropes and tripping lines! Tend the lifts and braces! Stand by!

Be careful to start nothing till the execution signal is hauled down, then:

SWAY!

Sway at the third roll if not working by signal.

Pause, till *all* the lifts and braces are clear, then

LOWER AWAY TOGETHER!

Keeping a good strain on the tripping lines.

The checking lines being hauled in and everything secure aloft:

LAY DOWN FROM ALOFT!

When the yards are crossed in the morning, the yard-rope is left stopped out to the quarter strap, and the bight overhauled down and stopped in to the slings; then at the first roll at sunset, the stop may be cut or broken; or toggle it with the tripping-line toggle.

TO CROSS TOPGALLANT AND ROYAL YARDS AND LOOSE SAIL TO A BOWLINE.

(Color evolution.)

When the preparatory signal is hoisted, call:

LOOSE SAIL! UP TOPGALLANT AND ROYAL YARDS!

Lead along the bowlines and halliards. (Indicates *manner* of loosing.)

On hauling down the preparatory:

TOPGALLANT AND ROYAL YARDMEN IN THE TOPS!

Send down the yard ropes!

At signal of execution: *Beat the call!*

ALOFT SAIL LOOSERS! *Set taut!* SWAY OUT OF THE CHAINS

Man the boom tricing lines!

SWAY ALOFT! TRICE UP! LAY OUT AND LOOSE!

Man the bowlines, halliards, and head outhauls!

As soon as the yards are high enough for crossing, the men on the topmast cap and jack cast adrift the gaskets of the light sails, keeping fast the lower bunt gasket, and hold the sails up.

When ready:

Roll off!

At the third roll (or when execution signal is hauled down),

SWAY ACROSS! LET FALL!

LAY IN! LAY DOWN FROM ALOFT!

At which order the men run away with the halliards and bowlines, and head outhauls.

BEND THE GEAR OF THE LIGHT SAILS!

The light yardmen lay down into the tops when they have bent the gear, and will lay down on deck at the order-

PIPE DOWN!

The evolution of fidding topgallant-masts, crossing yards and loosing sail is also frequently performed with a well-drilled crew, and is similar to the above, the masts being fidded first, and the sail loosers sent aloft when the yards are swayed out of the chains.

**TO SEND DOWN TOPGALLANT AND ROYAL YARDS
AND UNBEND SAIL.**

(Sails loosed to a bowline.)

Preparatory signal being made, call:

FURL AND UNBEND SAIL!

When preparatory is hauled down:

TOPGALLANT AND ROYAL YARDMEN IN THE TOPS!

Send down the yard ropes!

Man and tend the gear as in furling sail from a bowline. When execution signal is hoisted:

ALOFT TOPMEN! Lower yardmen on the sheer pole!

ALOFT LOWER YARDMEN! Haul taut! SHORTEN SAIL.

NOTE. If short-handed, it may be necessary to shorten sail before the topmen are sent aloft, in which case, **SHORTEN SAIL!** as execution signal is hoisted.

Man the boom tricing lines! TRICE UP!

LAY OUT! FURL AND UNBEND!

Get the light yards ready for coming down!

In addition to the gear named and manned in UNBENDING SAIL, man the yard-ropes and tripping-lines.

Tend the lifts and braces! Stand by!

As the signal of execution is hauled down:

SWAY! EASE AWAY!

Sway the yards, ease away the head-earings.

LOWER AWAY TOGETHER!

Lower the light yards on deck; unbend their sails.

LAY IN! *Stand by the booms!*

DOWN BOOMS!

LAY DOWN FROM ALOFT!

349

When the light sails are unbent-

Man the topgallant and royal yard ropes!

SWAY OUT IN THE CHAINS!

Square yards; clear up the decks and pipe down.

If in this instance the topgallant-masts are also to be sent down, take the strain off the fids* by swaying up on the mast-ropes before sending the men aloft.

After the yards are swayed, *and the royal yardmen off the jack*, the fid is drawn by the man on the cross-trees.

The order MAN THE MAST-ROPES would come in after SEND DOWN THE YARD-ROPES.

The yard-ropes in this instance reeve through jack-blocks, as explained further on.

SENDING UP AND DOWN TOPGALLANT-MASTS.

The Mast-rope reeves from aft forward through the topgallant top-block, at the topmast cap, then through the thimble of a lizard and the sheave in the heel of the mast. The end is hitched to a cap bolt on the opposite side.

The Lizard is long enough to pass through the royal sheave-hole, around the standing part of the mast-rope, and to secure with two half-hitches to its own part close to the thimble.

The Heel-rope is fitted with a tail-block, like a tripping-line. When in use its upper end is hitched to the link in the heel of the topgallant-mast; lower end and block paid down on deck.

Preventer Fid. If used, each mast is bored parallel to and about sixteen inches above the regular fid, to take a. preventer fid of iron, about an inch in diameter, with an eye in the end. To this eye is secured a laniard made fast to the eyes of the topmast rigging.

The reeving line has a tail-block which secures to the after topgallant shroud. Both ends of the whip are sent on deck, and one end secured to the mast-rope, previously rove through its top-block and lizard. When swayed aloft, hook the top-block, cast off the reeving line, and reeve the mast-rope.

The flying jib heel-rope reeves through a tail-block which secures to the jib-stay. Hitch the end of the heel-rope through the score in the heel. The flying jib down-haul is bent to the heel of the boom to assist in rousing in.

The flying jib, if bent, is roused in with the boom and secured alongside the jib-boom.

The flying jib-boom is not usually rigged in when *exercising* topgallant-masts.

Topgallant and royal yard-ropes. In port, when

* This does not mean to draw them, as topmen are likely to do, if not cautioned.

top-gallant-masts are to be frequently sent up and down, the mast-ropes are kept aloft ready for use, and the yard-ropes rove off through the jack-blocks at the eyes of the topgallant and royal rigging.

The topgallant-masts when down are landed up and down and forward of their respective masts. The flying jib-boom is rigged in alongside of the jib-boom, its end pointing through the wythe.

When the topgallant-mast is up and down, put a stop around the royal pole, securing it to lower stays. If there is any danger of the ship's rolling, secure the heel also, or land the mast on deck.

In swaying aloft to fid, when short-handed, the standing part of the mast-rope may lead through a second top-block, hooked to the eye-bolt where the end is usually hitched. The top burton of the side (led down on deck) is then hooked into a thimble clinched in the end of the mast-rope. After swaying the mast aloft as high as possible with the mast-rope, cross the deck and clap on the burton.

In unfidding, belay the mast-rope, pull up on the burton, out fid, belay burton, and lower with the mast-rope.

An iron traveler is substituted in many ships for the lizard, and is fitted as follows, Fig. 472, Plate 107.

The traveler is an iron hoop which goes around the mast and *both* parts of the mast-rope. It is leathered and fitted with a projecting eye on each side. Into these eyes are spliced the ends of two short spans.

One span, pointing downwards, has spliced to its centre a *distance line*, equal in length to the distance from the royal sheave hole to the bolt in the heel of the topgallant-mast. The other end of the distance line is permanently secured to this bolt.

The other span points upward, and has secured to its centre a checking line, which reeves through a small leader on the forward part of the topmast cap, thence to the deck.

In unfidding, when the mast is lowered the checking line is tended so as to keep a constant strain upon it. The iron ring travels up the mast the length of the distance line, and remains in place abreast of the royal sheave-hole, acting as a grommet or lizard.

In fidding, take through the slack of the checking line as the mast goes up, so as to keep the traveler in position. When the mast is pointed, let go the checking line, and the traveler falls to its usual place between the doubling's of the topmast and topgallant mast.

TO SEND DOWN TOPGALLANT-MASTS.

(Port Routine.)

Light yards on deck, using lizards. Preparatory signals being made, call-

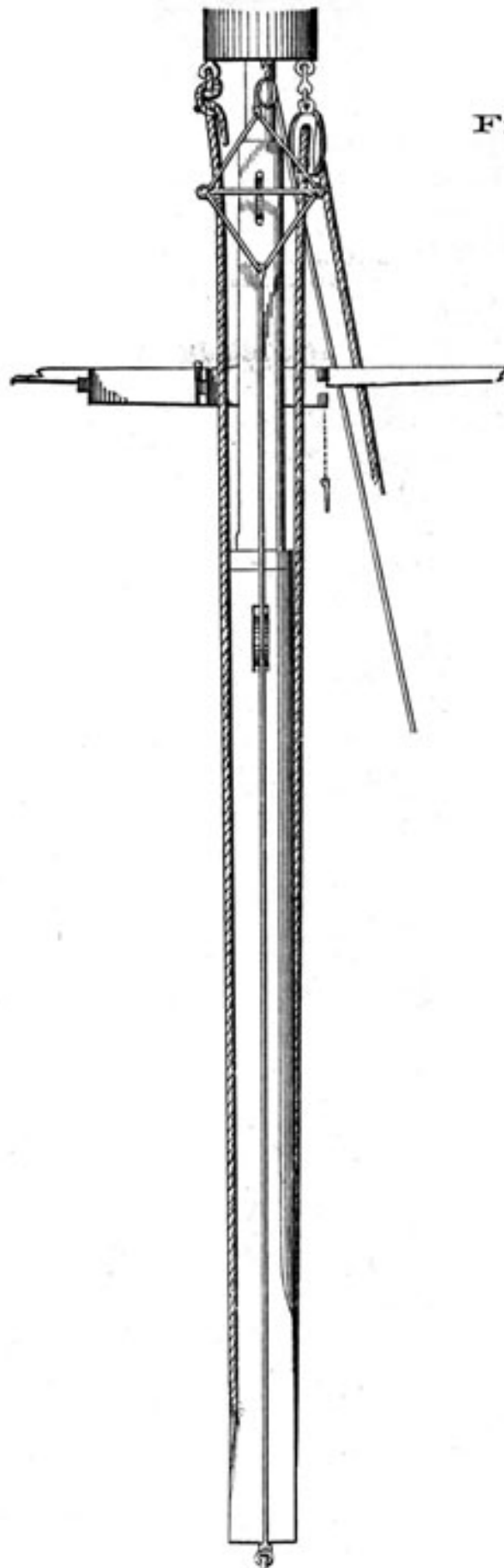
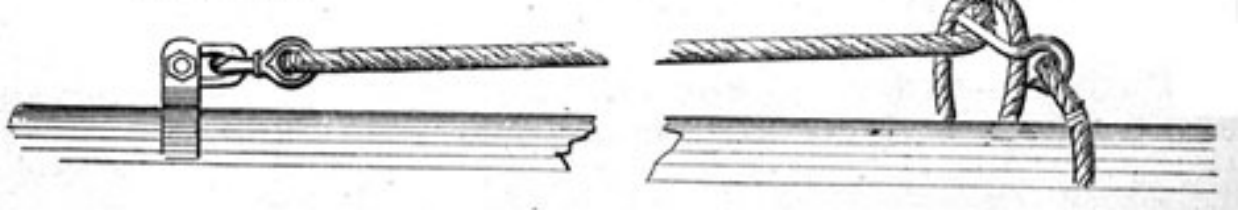


Fig.472

Fig.473



DOWN TOPGALLANT-MASTS!

On hauling down preparatory signal:

TOPGALLANT AND ROYAL YARDMEN IN THE TOPS!

Send down heel-ropes and reeving lines!

On deck. Get up the mast-ropes, and bend on the reeving lines ready to sway aloft. Let go all gear holding the mast; lifts, braces, and topgallant studding-sail halliards. Stand by to come up royal and topgallant back-stays.

In tops. Pay down reeving line abaft and heel-rope forward.

On hoisting of execution signal:

ALOFT TOPGALLANT AND ROYAL YARDMEN!

On deck, slack up topgallant and royal back-stays, stays and flying-jib guys; sway aloft the mast-ropes and topgallant top-blocks; lead out the mast-ropes.

Aloft. Slack up topgallant and royal shrouds and stays; hook topsail clew-jiggers to the crane lines on the back-stays, and haul them taut; unhook block (if any) at the heel of the topgallant-mast, shift to strap on collar of topmast stay, bend the heel-rope, secure the block of the reeving whip to the after topgallant shroud, and when mast-rope and block are swayed aloft, hook the block and reeve the mast-rope; cast off laniards of Jacob's ladder, and light up all the gear and topgallant shrouds.

On Flying jib-boom and bowsprit cap. Secure tail-block of heel-rope, pass the heel-rope, bend the flying jib down-haul to the heel of the boom; render the flying jib and royal stays through their scores, and cast off belly lashing, if used. Let go flying-jib halliards.

MAN THE TOPGALLANT MAST-ROPES!

Haul taut! SWAY AND UNFID!

Haul out the regular fid, stand by to haul out the preventer.

On bowsprit cap, unclamp the heel of the flying jib-boom. Take turns for lowering fore and aft (or for easing in).

Stand by! Men aloft draw preventer fid.

As signal of execution is hauled down:

LOWER AWAY TOGETHER! RIG IN!

Lower roundly till the topgallant-mast head is clear, then handsomely till the lizard is passed through the royal sheave-hole: haul on the heel-rope to keep the heel clear, and land the masts up and down with their heels on chocks. Ease in the flying jib-boom, hauling in on the down-haul; secure the spar alongside the jib-boom. In the chains and head stop in the bights of all topgallant and royal stays and back-stays.

Aloft. Open the gate when the topgallant-mast head is abreast of the cap; pass the lizard; secure the topgallant and royal funnels to the cap, and make everything snug about the cross-trees and in the tops.

352

As soon as the work is done;

LAY DOWN FROM ALOFT

TO SEND UP TOPGALLANT-MASTS.

(Port Routine.)

The mast-ropes being rove off.

Preparatory signal being made, call:

UP TOPGALLANT-MASTS

When preparatory signal is hauled down:

TOPGALLANT AND ROYAL YARDMEN IN THE TOPS

On deck. Lead out mast-ropes and heel-rope of flying jib-boom; have straps and jiggers ready for setting up topgallant and royal stays, back-stays and flying jib guys; let go royal and topgallant gear, lifts, braces, clewlines, buntlines, &c., and topgallant studding-sail halliards.

Send down the reeving lines and heel-ropes! If the former are to be used, and the latter are not already on deck.

MAN THE TOPGALLANT MAST-ROPES

At the same time man the flying jib heel-rope.

Signal of execution being hoisted:

ALOFT TOPGALLANT AND ROYAL YARDMEN!

At cross-trees. Cut stops on royal and topgallant stays.

At the cap. Place the truck and funnels fair for receiving the topgallant-mast; see signal halliards and royal braces clear.

In the tops. Cut the stops on the topgallant and royal shrouds; thence to the topsail-yard to keep mast on the right slue.

Forward. Cast off lashings that secure flying jib-boom; have clamp ready for heel.

At hauling down of execution signal:

SWAY ALOFT!

Men on the topsail-yard keep the mast on the right slue for fidding, using a heaver through the heel.

At the cross-trees. The lizard is cast off and mast-head pointed; clamp the gate when the heel is above the topsail-yard; light up rigging: stand by with preventer, then with regular fid.

On the cap. Place the truck and funnels.

The flying jib-boom is roused out by its heel-rope, bearing down on the heel if necessary.

When the sheave of the topgallant-mast arrives above the cap, shorten in on the mast-rope.

As execution signal is hauled down:

SWAY AND FID!

At the topmast cap keep the Jacob's ladder

from fouling;* give timely warning if any gear holds the mast; prepare reeving line to send down mast-rope, if desired.

At cross-trees shove in preventer, and then regular fid as soon as possible. When fid is in, sing out "*Launch!*"

Cast off the mast-rope, send it down with the top-block, by the reeving line, if desired, then carry, the latter into the top. Unhook clew-jiggers from crane lines.

Set up all topgallant and royal shrouds, stays and back-stays; haul taut on deck all topgallant and royal gear; stow away mast-ropes, luffs, and jiggers.

When ready aloft:

LAY DOWN FROM ALOFT!

If these exercises are to be continued the mast-ropes remain rove off in port.

TO SEND DOWN TOPGALLANT AND ROYAL YARDS AND TOPGALLANT MASTS.
(Color evolution.)

Mast ropes rove off.

The preparatory signal being made, call:

DOWN TOPGALLANT AND ROYAL YARDS AND TOPGALLANT MASTS!

Men go to their stations for sending down the light yards excepting those who can be spared to prepare for coming up the topgallant and royal back-stays, &c.

On hauling down of preparatory signal:

TOPGALLANT AND ROYAL YARDMEN IN THE TOPS! *Send down the yard-ropes and heel-ropes!*

The execution signal being hoisted:

Beat the call, or

ALOFT TOPGALLANT AND ROYAL YARDMEN!

Man the yard ropes and tripping lines!

Tend the lifts and braces! Stand by!

As execution signal is hauled down,

Roll off! At third roll:

SWAY! LOWER AWAY!

The men on the jack lay down to the cross-trees as soon as the yards are swayed.

MAN THE MAST-ROPES! SWAY AND UNFID

When ready: LOWER AWAY TOGETHER! RIG IN!

And when everything is secure aloft:

LAY DOWN FROM ALOFT

* A small quarter-round chock on after part of topmast-head will accomplish this purpose. Similarly a scored wedge forward on the under side of the cap is wisd to prevent the hounds from catching.

23

354

TO SEND UP TOPGALLANT MASTS AND TOPGALLANT AND ROYAL YARDS.

(Color evolution.)

Masts up and down.

The preparatory signal being made, call:

UP TOPGALLANT MASTS AND TOPGALLANT AND ROYAL. YARDS!

Men go their stations for sending up topgallant masts. When preparatory signal is hauled down:

TOPGALLANT AND ROYAL YARDMEN IN THE TOPS!

Man the topgallant mast ropes!

At the same time man the flying jib heel rope.

When the signal of execution is hoisted,

ALOFT TOPGALLANT AND ROYAL YARDMEN! SWAY ALOFT AND FID!

When fidded, "*Launch*" (the fore, main, or mizzen). Then go to stations for crossing light yards.

MAN THE YARD ROPES! *Beat the call!* SWAY OUT OF THE CHAINS!

When the yards are up and down:

SWAY ALOFT!

Proceed as in sending up topgallant and royal yards. When ready for crossing:

Tend the lifts and braces!

Stand by! As signal is hauled down, *Roll off!* At the third roll:

SWAY ACROSS! BEND THE GEAR!

And when ready:

LAY DOWN FROM ALOFT!

For quick work the topgallant mast ropes and topgallant yard ropes should be on the same side, the men turning from one to the other.

PORT ROUTINE-MISCELLANEOUS.

To Rig Out and In Lower Booms. Having the booms rigged for port and ready, order: *Man the boom topping-lifts! Forward guys!* This gear is manned, both sides equally, if by the watch, first part starboard side, second part port side, and have a hand to tend the after-guy.

Haul taut! TOP UP!

Walk away with the topping lifts until the blocks are down to the mark. When, RIG OUT! ease away the after-guys and square the booms.

To get them alongside-*Man the after-guys! Tend the topping-lift and forward guy! Set taut!* HAUL AFT!

To Spread Awnings. Place the awning stanchions and ridge ropes, get the awnings up out of the sail room and fore-and-aft in their respective parts of the ship. (If awnings are up and on a stretch they must be slacked down together to loose). Call:

SPREAD AWNINGS!

Loose the awnings, haul out on the fore-and-aft tackles, reeve and man the earings. When ready,

HAUL OUT! and when the earings are out,

LAY UP AND BRING TO!

The men all lay out together, haul out the side stops, expending the ends. Pass the lacings connecting the different awnings. When finished, **LAY IN!**

Let go crow-foot halliards before hauling out earings and stops, and haul taut again after these are passed.

To Furl Awnings. Call:

FURL AWNINGS!

Men being up:

LAY UP AND CAST OFF SIDE STOPS!

At the same time cast adrift the lacings. When ready,

EASE AWAY! LAY IN!

The earings are eased away together; the men lay in, roll up the awnings neatly, hook the fore-and-aft tackles, and **HAUL OUT!** together.

Hammock Girtlines and Harbor Clothes-lines are fitted double. In the bight of the line is seized a hook and thimble; the hook secures to a bolt in the stern. The two lines leading forward pass through thimbles in rope jackstays that hang up and down each mast. Forward, the ends of the lines are spliced together around the after-sheave of a fiddle-block. Through the forward sheave is rove a whip, one end spliced into a block hooked at the bowsprit cap, the other rove through the fiddle-block, and thence through the block on the cap and inboard.

The rope jackstay at each mast has an eye in its upper end for the mast-whip and a tail at the lower end to use as a down-haul.

These lines are prepared beforehand, and triced up at the third roll at sunset, at which time boats are also hoisted.

To Lower Wash Clothes with the Awnings Spread; after the men are on deck:

Stand by to lay out! When ready, LAY OUT! *Cast off side tops-EASE AWAY!* LAY IN!

Easing away the earings and slacking the lacings, then:

PIPE DOWN! the clothes; and when the lines are triced up again, or unhooked for sending below, haul out the earings; *Stand by to lay out!* &c., as in spreading awnings.

Have the master-at-arms and ship's corporals on deck to

356

look out for clothing of men away in boats. See the *lines* weeded of rope-yarns before tricing up again or stowing below, but it is still better to enforce the use of regular clothes stops, which are secured to the clothing and cast adrift, not cut.

In firing a salute, with scrubbed hammocks or clothes on the lines, man the down-hauls and lower and haul down before the first gun, tricing up again after the last gun.

Dressing Ship. Ships are either dressed *rainbow* or *yard-arm* fashion.

In the first case an arch of flags extends from the water's edge to the jib-boom,* thence to the topgallant mastheads, spanker gaff and boom, and to the water's edge astern.

By the second method the flags are bent on to the signal halliards, which are rove through the topgallant stun'-sail halliard blocks, and sent down *forward* of all. When the flags are triced up the halliards are hauled out to all the yardarms and lower boom ends, hanging to the water's edge.

The best way is to combine both methods, if there be flags enough, or use the rainbow, and in addition, dress the main, yard-arm fashion.

In any case, the ensign of the nation in whose honor the display is made is hoisted at the fore, the American ensign being hoisted at the main and mizzen. No other national flags are used in dressing ship.

To perform the evolution properly, there should be fitted *dressing lines* of small rope to which the numbers are stitched, each dressing line having a down-haul bent on in the centre.

The forward one goes from the jib-boom end to the fore-topgallant masthead, and is hoisted by the flying jib halliards or other whip.

The dressing lines between the masts are hoisted by the royal yard-ropes, previously unrove from their sheaves and taken through blocks at the topgallant mastheads.

At the main and mizzen reeve off additional whips *abaft* the masts. The whip abaft the mizzen mast trices

up the dressing line that leads from the mizzen topgallant masthead to the gaff (where it is hauled out by one set of the peak ensign halliards), and thence to the spanker-boom end.

The ends of the dressing lines forward and aft drop from the jib-boom and spanker boom ends to the water's edge.

They are decorated with the boat numbers and other small bunting, and steadied by hand leads at the ends.

Care and taste are necessary in placing the flags. They should be equidistant. Use the square flags between the mastheads and the pennants forward and aft, or alternate flags and pennants throughout.

Topgallant-yards are generally not sent down on the

* *Vide* Navy Signal Book.

357

evening previous to dressing ship; but, should they be, cross them in the morning in good season.

The royal halliards and other whips are prepared aloft, overhauled down and bent to the dressing lines.

When the call is beaten, round up the masthead ensigns made up, and send aloft the captain of each top and two hands, one of whom, going to the masthead, stops the tack in when broke; the other, remaining in the top, clears the flags should they foul.

Man the whips! And at colors.*

Break stops! TRICE TIP!

The principal beauty of the manoeuvre is to have everything so prepared that the masthead flags are displayed and the others triced up so as to reach their places readily. If yard-arm fashion, hands previously sent aloft lay out together at the same time to each yard-arm, stopping out the flag halliards, and then, at the word, laying in together.

On a shift of wind, or at the turn of the tide, if lying in a tideway, send hands aloft together to clear the flags.

At sunset, haul the flags down just before sending down the topgallant yards.

Manning Yards. Men for manning yards will be selected from the furlers and men stationed in tops at furling, as far as practicable, except those for the cross-jack yard, who will be taken from the afterguard not stationed on the main-yard.

Before the time to man yards, the men selected for the several yards will be assembled by watches on

their respective sides, facing forward, as follows: Those for the head yards, on the fore-castle: for the main yards, in the gangways; and for the yards on the mizzen, on the quarterdeck; lower yardmen inside of the topsail and topgallant yardmen.

The several captains, petty officers, and leading men will tell off their men from forward, in the order of their numbers on the yards, and size them, placing the tallest men in the bunt and the shortest at the yard-arms.

Prepare to man in a similar way the head booms and spanker boom; also the lower booms, unless the men there would interfere with the firing of salutes. On the head booms the tallest man is inboard; on the spanker boom the tallest man is forward.

The prevailing practice at present is to leave the royal yards in the rigging, and instead of manning topgallant yards (especially in small vessels), to station four hands on the cross-trees and two on the jack.

As soon as the selection for each yard is told off and sized, four men for each lower and topsail yard, and two

* It is usual to dress ship at sunrise, in which case the colors should be hoisted at that time.

358

for each topgallant yard, with two men for the tops, will be ordered aloft to attach the life-lines, laying down afterwards into the tops or on deck.

The life-lines will be rove through tail-blocks, made fast to the slings, tyes, and yard-ropes (those to the latter being steadied by a turn around the masts), the other ends hitched or seized to the lifts at points which will bring the lines breast high when hauled taut, the ends sent on deck. If the yards are not to be manned immediately, the men preparing the life-lines, before laying down, will stop them along the lifts down to the yards and in the slings, with cut or split rope-yarns, and lay down from aloft.

When the evolution is to be performed, the men are sent aloft. When in the slings the order will be given to "*Stand by!*" The stops will be broken and the life-lines hauled taut on deck and secured. At the order "*LAY OUT,*" the men will lay out as sized.

The yard-arm men extend their outside arms straight, holding on by the lift, while they clap their inner arms over the life-lines, holding it fast under the arm-pit; the next man in the same way extends his outer arm, and grapples the shoulder of the yard-arm man; then passes his inner arm over the life-line, clasping it under his arm-pit, and so on to the bunt.

The appearance of the boat, at whatever distance it may be, is the customary signal for manning yards; yet it is preferable to judge of the distance, and act so that the men may not be more than ten minutes aloft.

The men on the yards ought to face the boat; that is, when the boat is abaft the beam, they ought to face aft: when before the beam, forward; but in a ship, when the person saluted ascends the side, the hands on

the cross-jack and mizzen topsail yards ought to face forward-all others as before, aft.

When directed to "LAY IN," the outer men will cast off the life-lines from the lifts, and the inner men the tail-blocks in the slings, and will stand by to lay down from aloft when ordered.

Men are not usually assigned by watch numbers on a station bill for manning yards, in consequence of the necessity for sizing and the liability of absence from various causes.

Cockbilling Yards-Mourning. The most appropriate time for cockbilling yards is daylight, and dark the proper time for squaring them again.*

At the hour selected, hoist the colors half-mast, sway up the topgallant yards, slip the lizard, parrel the yards, and cockbill them with the others previously reversed.

* In half-masting colors, first hoist them to the peak, then lower. Similarly in hauling down half-masted colors, hoist first to the peak.

359

In topping up the lower yards a burton is required to assist the lift in topping.

To allow the topsail yards to top up properly, they must be hoisted two feet off the caps, the parrels and braces must be slacked. Trysail and spanker gaff should be lowered well down, and swinging booms dropped into the water.

The way of topping the yards ought to be governed by the side on which the topgallant yards are sent up; for instance, as the main topgallant yard is sent up on the starboard side, the main and main topsail yards should be topped to port. Getting them in line, when topped, should be done with reference to lower yards; which, in the first place, are topped as high as the top rims will allow; then being squared by the braces, the topsail and topgallant yards have only to be parallel.

The lower yards top up better by the burtons alone.

For painting ship, scraping spars, &c., see Appendix H.



[Previous Part](#)



[Seamanship
Home Page](#)



[Next Part](#)

Copyright (C) 2006 [Historic Naval Ships Association](#)

All Rights Reserved

[Legal Notices and Privacy Policy](#)

Version 1.00, 24 Apr 06

VESSELS' LIGHTS AND THE RULE OF THE ROAD.

THE following articles from the "Revised International Regulations for Preventing Collisions at Sea," are adopted for the naval service of the United States, in so far as the navigation of naval vessels outside of United States territorial waters is concerned:

ARTICLE I. *Preliminary.*-In the following rules every steamship which is under sail and not under steam is to be considered a sailing ship; and every steamship which is under steam, whether under sail or not, is to be considered a ship under steam.

ARTICLE II. *Rules concerning Lights.*-Lights mentioned in the following articles numbered 3, 4, 5, 6, 7, 8, 9, 10 and 11, and no others, shall be carried in all weathers from sunset to sunrise.

ARTICLE III. A sea-going steamship when under-way shall carry:

(a.) On or in front of the foremast, at a height above the hull of not less than 20 feet, and if the breadth of the ship exceeds 20 feet, then at a height above the hull not less than such breadth, a bright white light, so constructed as to show an uniform and unbroken light over an arc of the horizon of twenty points of the compass, so fixed as to throw the light ten points on each side of the ship, viz., from right ahead to two points abaft the beam on either side, and of such a character as to be visible on a dark night, with a clear atmosphere, at a distance of at least five miles.

(b.) On the starboard side, a green light so constructed as to show an uniform and unbroken light over an arc of the horizon of ten points of the compass, so fixed as to throw the light from right ahead to two points abaft the beam on the starboard side, and of such a character as to be visible on a dark night, with a clear atmosphere, at a distance of at least two miles.

(c.) On the port side, a red light so constructed as to show an uniform and unbroken light over an arc of the horizon of ten points of the compass, so fixed as to throw the light from right ahead to two points abaft the beam on the port side, and of such a character as to be visible on

a dark night, with a clear atmosphere, at a distance of at least two miles.*

(d.) The said green and red side lights shall be fitted with inboard screens projecting at least three feet forward from the light, so as to prevent these lights from being seen across the bow.

ARTICLE IV. A steamship, when towing another ship, shall, in addition to her side lights, carry two bright white lights in a vertical line one over the other, not less than three feet apart, so as to distinguish her from other steamships. Each of these lights shall be of the same construction and character, and shall be carried in the same position as the white light which other steamships are required to carry.

ARTICLE V. A ship, whether a steamship or sailing ship, when employed either in laying or picking up a telegraph cable, or which, from any accident, is not under command, shall at night carry, in the same position as the white light which steamships are required to carry; and if a steamship, in place of that light, *three red lights in globular lanterns, each not less than ten inches in diameter, in a vertical line one over the other, not less than three feet apart*; and shall by day carry in a vertical line one over the other, not less than three feet apart, in front of but not lower than her foremast-head, three black balls or shapes, each two feet in diameter.

These shapes and lights are to be taken by approaching ships as signals that the ship using them is not under command, and cannot therefore get out of the way.

The above ships, when not making any way through the water, shall not carry the side lights, but when making way shall carry them.

ARTICLE VI. A sailing ship under way, or being towed, shall carry the same lights as are provided by Article 3 for a steamship under way, with the exception of the white light, which she shall never carry.

ARTICLE VII. Whenever, as in the case of small vessels during bad weather, the green and red side lights cannot be fixed, these lights shall be kept on deck, on their respective sides of the vessel, ready for use, and shall, on the approach of or to other vessels, be exhibited on their respective sides in sufficient time to prevent collision, in such manner as to make them most visible, and so that the green light shall not be seen on the port side nor the red light on the starboard side.

To make the use of these portable lights more certain and easy, the lanterns containing them shall each be painted outside with the color of the light they respectively contain, and shall be provided with proper screens.

*Knowing that *port* wine is red, the side lights may be easily remembered.

ARTICLE VIII. A ship, whether a steamship or a sailing ship, when at anchor, shall carry, where it can best be seen, but at a height not exceeding twenty feet above the hull, a white light in a globular lantern of not less than eight inches in diameter, and so constructed as to show clear, uniform, and unbroken light, visible all round the horizon at a distance of at least one mile.

ARTICLE IX. A pilot vessel, when *engaged on her station on pilotage duty*, shall not carry the lights required for other vessels, but shall carry a white light at the mast-head, visible all round the horizon, and shall also exhibit a flare-up light, or flare-up lights, at short intervals, which shall never exceed fifteen minutes.

A pilot vessel, *when not engaged on her station on pilotage duty*, shall carry lights similar to those of other ships.

ARTICLE X. (a.) Open fishing boats and other open boats, when under way, shall not be obliged to carry the side lights required for other vessels, but every such boat shall, in lieu thereof, have ready at hand a lantern with a green glass on the one side and a red glass on the other side, and on the approach of or to other vessels such lantern shall be exhibited, in sufficient time to prevent collision, so that the green light shall not be seen on the port side nor the red light on the starboard side.

(b.) A fishing vessel and an open boat, when at anchor, shall exhibit a bright white light.

(c.) A fishing vessel, when employed in drift-net fishing, shall carry on one of her masts *two red lights* in a vertical line one over the other, not less than three feet apart.

(d.) A trawler at work shall carry on one of her masts *two lights* in a vertical line one over the other, not less than three feet apart, *the upper light red and the lower green*, and shall also either carry the side lights required for other vessels, or, if the side lights cannot be carried, have ready at hand the colored lights, as provided in Article 7, or a lantern with a red and a green glass, as described in paragraph (a) of this article.

(e.) Fishing vessels and open boats shall not be prevented from using a flare-up in addition, if they desire to do so.

(f.)

(g.) All lights required by this article, except side lights, shall be in globular lanterns so constructed as to show all round the horizon.

ARTICLE XI. A ship which is being overtaken by another shall show from her stern to such last-mentioned ship a white light or a flare-up light.

ARTICLE XII. *Sound signals for a fog, &c.*-A steamship shall be provided with a steam-whistle or other efficient steam-sound signal, so placed that the sound may not be intercepted by any obstructions, and with an efficient foghorn to be sounded by a bellows or other mechanical means,

and also with an efficient bell. A sailing ship shall be provided with a similar fog-horn and bell.

In fog, mist, or falling snow, whether by day or night, the signals described in this article shall be used as follows, that is to say:

(a.) A steamship under way shall make with her steam-whistle, or other steam-sound signal, at intervals of not more than two minutes, a prolonged blast.

(b.) A sailing ship under way shall make with her foghorn, at intervals of not more than two minutes, when on the *starboard tack one blast*, when on the *port tack two blasts* in succession, and when with the wind *abaft the beam three blasts* in succession.

(c.) A steamship and sailing ship, when not under way, shall, at intervals of not more than two minutes, ring the bell.

ARTICLE XIII. *Speed of ships in a fog.*-Every ship, whether sailing ship or steamship, shall, in a fog, mist, or falling snow, go at a moderate speed.

ARTICLE XIV. *Steering and sailing rules.*-When two sailing ships are approaching one another so as to involve risk of collision, one of them shall keep out of the way of the other, as follows, viz.:

(a.) A ship which is running free shall keep out of the way of a ship which is close-hauled.

(b.) A ship which is close-hauled on the port tack shall keep out of the way of a ship which is close-hauled on the starboard tack.

(c.) When both are running free with the wind on different sides, the ship which has the wind on the port side shall keep out of the way of the other.

(d.) When both are running free with the wind on the same side, the ship which is to windward shall keep out of the way of the ship which is to leeward.

(e.) A ship which has the wind aft shall keep out of the way of the other ship.

ARTICLE XV. If two ships under steam are meeting end on, or nearly end on, so as to involve risk of collision, each shall alter her course to starboard, so that each may pass on the port side of the other.

This article only applies to cases where ships are meeting end on, or nearly end on, in such a manner as to involve risk of collision, and does not apply to two ships which must, if both keep on their respective courses, pass clear of each other.

The only cases to which it does apply are, when each of the two ships is end on, or nearly end on, to the

other; other words, to cases in which, by day, each ship sees the masts of the other in a line, or nearly in a line, with her own; and, by night, to cases in which each ship is in such a position as to see both the side lights of the other.

364

It does not apply, by day, to cases in which a ship sees another ahead crossing her own course, or, by night, to cases where the red light of one ship is opposed to the red light of the other, or where the green light of one ship is opposed to the green light of the other, or where a red light without a green light, or a green light without a red light, is seen ahead, or where both green and red lights are seen any where but ahead.

ARTICLE XVI. If two ships under steam are crossing so as to involve risk of collision, the ship which has the other on her own starboard side shall keep out of the way of the other.

ARTICLE XVII. If two ships, one of which is a sailing ship and the other a steamship, are proceeding in such directions as to involve risk of collision, the steamship shall keep out of the way of the sailing ship.

ARTICLE XVIII. Every steamship, when approaching another ship so as to involve risk of collision, shall slacken her speed or stop and reverse if necessary.

ARTICLE XIX. In taking any course authorized or required by these regulations, a steamship under way may indicate that course to any other ship which she has in sight by the following signals on her steam-whistle, viz.:

One short blast to mean "I am directing my *course to starboard*." *Two short blasts* to mean "I am directing my *course to port*." *Three short blasts* to mean "I am going *full speed astern*."

The use of these signals is optional; but if they are used the course of the ship must be in accordance with the signal made.

ARTICLE XX. *Notwithstanding anything contained in any preceding article*, every ship, whether a sailing ship or a steamship, overtaking another, shall keep out of the way of the overtaken ship.

ARTICLE XXI. *In narrow channels* every steamship shall, when it is safe and practicable, keep to that side of the fair-way or midchannel which lies on the *starboard side* of such ship.

ARTICLE XXII. Where, by the above rules, one of two ships is to keep out of the way, the other shall keep her course.

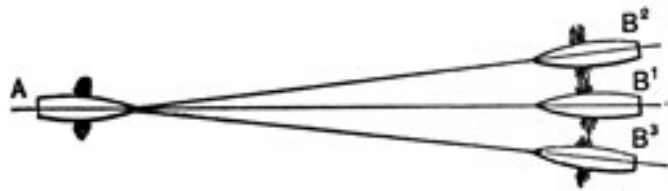
ARTICLE XXIII. In obeying and construing these rules, due regard shall be had to all dangers of navigation, and to any special circumstances which may render a departure from the above rules necessary in order to avoid immediate danger.

ARTICLE XXIV. *No ship to neglect proper precautions*. -Nothing in these rules shall exonerate any ship,

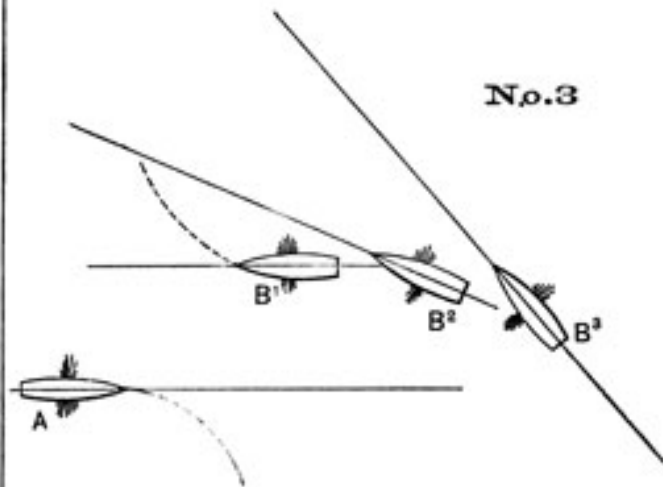
or the owner, or master, or crew thereof, from the consequences of any neglect to carry lights or signals; or of any neglect to keep a proper lookout, or of the neglect of any precaution

Plate 108

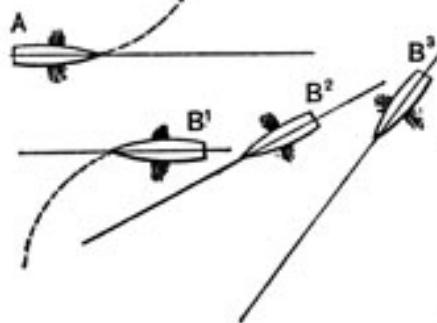
No.1



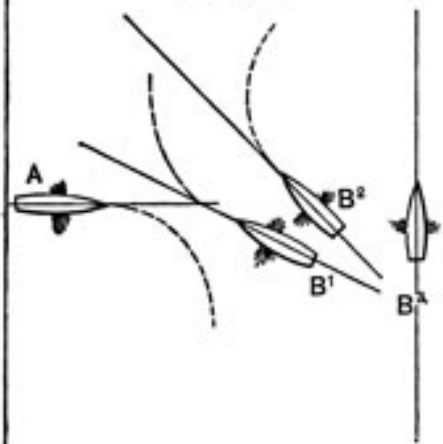
No.3



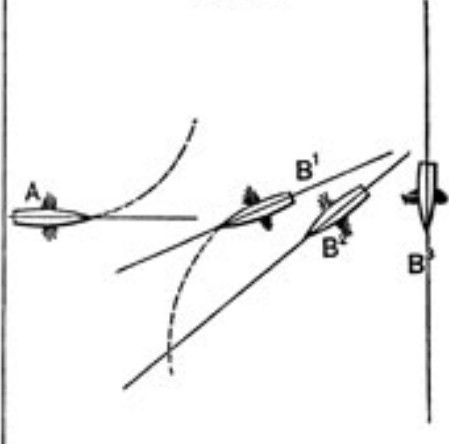
No.2



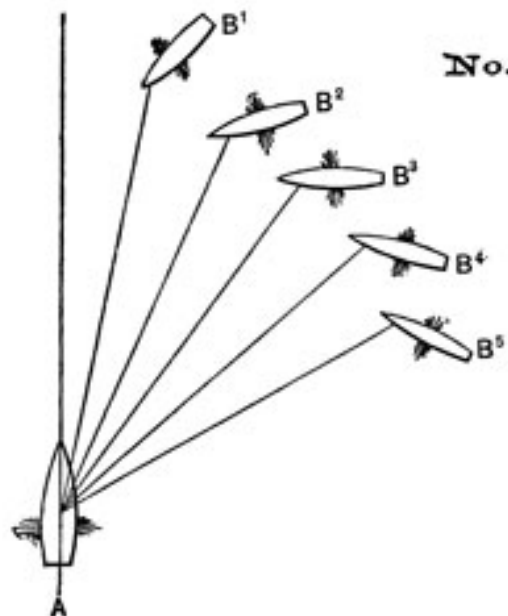
No.6



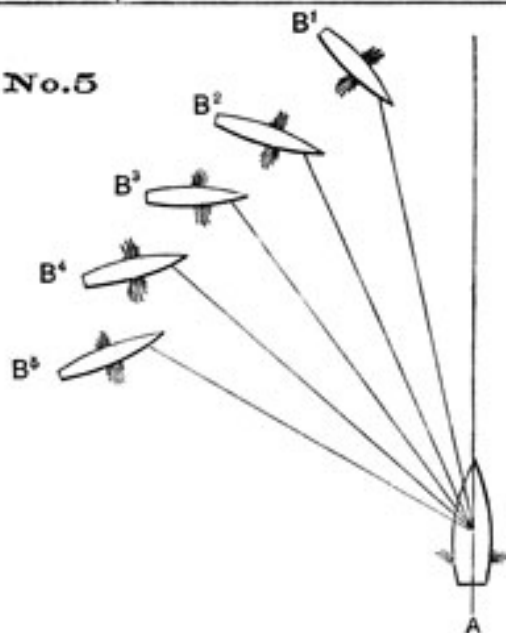
No.7



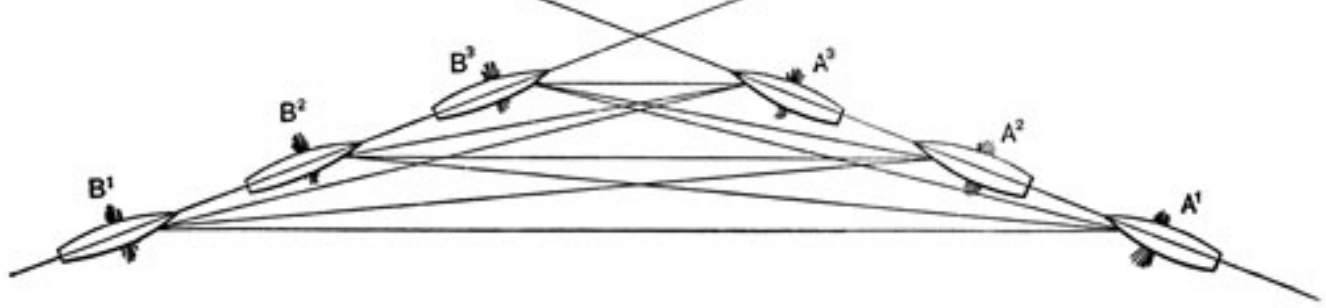
No.4



No.5



No.8



which may be required by the ordinary practice of seamen, or by the special circumstances of the case.

ARTICLE XXV. *Rules for Harbors and Inland Waters.* -Nothing in these rules shall interfere with the operation of a special rule, duly made by local authority, relative to the navigation of any harbor, river, or inland navigation.

ARTICLE XXVI. *Signal Lights for Squadrons and Convoys.*-Nothing in these rules shall interfere with the operation of any special rules made by the government of any nation with respect to additional station and signal lights for two or more ships of war, or for ships sailing under convoy.

Diagrams Illustrating, the Rule of the Road at Sea. Plate 108, Figures 1 to 7, are suggestions for the handling of steamers, Figure 8 for vessels close-hauled under canvas alone.

In addition to the side-lights mentioned herein, an approaching steamer shows her white mast-head light, the mast-head light having a compass range equal to that of both side lights, and being visible at more than twice the distance.

In Figure 1, A and B are in such positions that each sees both side lights of the other, dead ahead, or nearly so. This is the case provided for in Article XV. Both A and B put their helms to port without hesitation.

In Figure 2, A sees on her starboard side the green light of B, and B sees on her starboard side the green light of A; they are therefore passing to starboard. The precaution of giving a good berth in passing should be taken by putting the helms of both vessels to starboard, if necessary, till out of danger of collision.

In Figure 3, A sees on her port side the red light of B, and B sees on her port side the red light of A; they are therefore passing to port. If in any doubt as to the distance at which they would pass by continuing on their course, both vessels should put their helms to port until out of danger of collision.

In Figure 4, A sees, a point or more on her starboard bow, the red light of B, and B sees on her port bow the green light of A. The vessels are converging, and A has the other vessel evidently on her own starboard side. It is A's duty to keep clear, which may be done by slowing, putting helm a-port, and stopping, if necessary, to pass astern of B. B stands on, minding her port helm in this case.

In Figure 5, A sees, a point or more on her port bow, the green light of B, and B sees on her starboard bow the red light of A. The vessels are converging, and A has the other vessel clearly on her own port side. A stands on; it is B's duty to keep clear, which may be done by slowing, porting and stopping, if necessary, to pass astern of A; in which case A minds her port helm.

366

In Figure 6, A sees ahead, or very nearly ahead, the red light of B, and B, whether he sees only A's green light, as at B, or both of A's lights, as at B₂ B₃, has A obviously on his port side. B is crossing the bows of A in some direction to port. A probably ports to pass astern of B, in which case B ports if necessary, to avoid collision.

In Figure 7, A sees ahead, or very nearly ahead, the green light of B, and B, whether he sees only A's green light, as at B, or both of A's lights, as at B₂ B₃, has A evidently on his starboard side. B is crossing the bows of A in some direction to starboard. B probably starboards to avoid collision, in which case A starboards if necessary.

Figure 8 represents a sail B₁ B₂ B₃ close-hauled on the port tack, giving way to A₁ A₂ A₃ close-hauled on the starboard tack by porting, A holding her own on her course close-hauled.

NOTES ON THE RULES OF THE ROAD.

The *general* rule of the road for steamers is the same as the general rule of the pavement for foot passengers, that in all ordinary cases two steamships meeting face to face, or "end on or nearly end on," so as to involve risk of collision, shall port; that is to say, shall keep to the right. Nothing could be more simple than this.

But a man who crosses from the extreme left of a pavement to its right side because he sees another man approaching to his right, cannot justify his proceeding by this rule. He was obviously not "end on or nearly end on," and by his action he places himself in the way of the other.

The *particular* rule of the road for steamers is that if they are crossing, that steamer which has the other on her own right hand side shall keep out of the way.

There are *eight* cases in which it is your duty to alter course to avoid the risk of collision:

1. In a steamer meeting a steamer end on, or nearly end on.
2. In a steamer nearing a sailing vessel.
3. In a steamer approaching another on your own starboard side.
4. If under sail on the port tack, nearing a vessel under sail on the starboard tack.

5. If under sail *going free*, meeting a vessel under sail close-hauled.
6. If under sail *going free*, nearing another vessel under sail *to leeward*, also going free with the wind on the same side.
7. If under sail going free with the wind on the port side, meeting another vessel under sail going free with wind on the starboard side.

367

8. In a steamer or sailing vessel approaching another vessel whose lights show that she is at anchor, or not under control, and therefore unable to get out of your way.

In only *one* of these cases is it right to *port* the helm without further consideration, viz., in the first case.

In all other cases the course should not be altered until by bearings taken at an interval, or by bringing the ship on with some part of the rigging, and watching whether she draws aft or forward, it is ascertained that the vessels are converging, and which is the *best way* to alter the course to avoid collision.

A fruitful cause of collision is that the ship which has by the rules to alter her course does not do so promptly and sufficiently to show to the other ship that she knows her duty and is performing it. When this is not done the other ship is often led to adopt some wrong course to avoid collision, and thus bring it to pass. Decide upon your action and then act *promptly*. If under steam, a slight yaw will show the direction you intend to take; if under sail and about to tack, let fly the jib sheet; if about to bear up, shiver the mizzen topsail or brail up the spanker.

AIDS TO MEMORY.
BY THOMAS GRAY.

1. Two Steamships Meeting:

When *both* side lights you see ahead,
Port your helm and show your RED.

2. Two Vessels Passing:

GREEN to GREEN or RED to RED,
Perfect safety-go ahead!

3. Two Steamships Crossing:

(NOTE-This is the position of greatest danger, requiring caution and judgment.)

If to your starboard RED appear,
It is your duty to keep clear;

To act as judgment says is proper:-
To port, or starboard, back, or stop her!

But, when upon your port is seen
A steamer's starboard light of GREEN,
There's not so much for you to do,
For GREEN to port keeps clear of you.

4. All Ships must keep a good Lookout, and Steam-vessels stop, &c.

Both in safety and in doubt,
Always keep a good lookout.
In danger with no room to turn,
Ease her! Stop her! Go astern.

368

And the following may be added as a
General Rule for Sailing Vessels:

If close-hauled on the *starboard tack*,
No other ship can cross your track;
If on the *port tack* you appear,
Ships going free must all keep clear;
While you must yield, *when going free*,
To sail close-hauled, or on your lee.
Both free, with wind on different sides,
Rule XIV, *c*, your case decides,
And if you have the wind right aft,
Keep clear of every sailing craft.

UNITED STATES PILOT RULES FOR LAKE AND SEABOARD.

Rules and Regulations for the government of pilots navigating seas, gulfs, lakes, bays, sounds, or rivers, except rivers flowing into the Gulf of Mexico, and their tributaries. Revised and adopted by the Board of Supervising Inspectors, June 10, 1871. (Amended to February 28, 1882.)

RULE I.-When steamers are approaching each other "head and head," or nearly so, it shall be the duty of each steamer to pass to the right, or port side of the other; and the pilot of either steamer may be first in determining to pursue this course, and thereupon shall give, as a signal of his intention, one short and distinct blast of his steam-whistle, which the pilot of the other steamer shall answer promptly by a similar blast of his steam-whistle, and thereupon such steamers shall pass to the right, or port side of each other. But if the course of such steamers is so far on the starboard of each other as not to be considered by pilots as meeting "head and head," or nearly so, the pilot so first deciding shall immediately give two short and distinct blasts of his steam-whistle, which the pilot of the other steamer shall answer promptly by two similar blasts of his steam-whistle, and they shall pass to the left, or on the starboard side, of each other.

NOTE.-In the night, steamers will be considered as meeting "head and head" so long as both the colored lights of each are in view of the other.

RULE II.-When steamers are approaching each other in an oblique direction (as shown in diagram of the fourth situation) they shall pass to the right of each other, as if meeting "head and head," or nearly so, and the signals by whistle shall be given and answered promptly, as in that case specified.

RULE III.-If, when steamers are approaching each other, the pilot of either vessel fails to understand the

369

course or intention of the other, whether from signals being given or answered erroneously, or from other causes, the pilot so in doubt shall immediately signify the same by giving several short and rapid blasts of the steam-whistle; and if the vessels shall have approached within half a mile of each other, both shall be immediately slowed to a speed barely sufficient for steerage-way until the proper signals are given, answered, and understood, or until the vessels shall have passed each other.

RULE IV.-When steamers are running in a fog or thick weather, it shall be the duty of the pilot to cause a long blast of the steam-whistle to be sounded at intervals not exceeding one minute.

Steamers, when DRIFTING or at ANCHOR in the fair-way of other vessels in a fog or thick weather, shall *ring their bells* at intervals of not more than two minutes.

RULE V.-Whenever a steamer is nearing a short bend or curve in the channel, where from the height of the banks or other cause, a steamer approaching from the opposite direction cannot be seen for a distance of half a mile, the pilot of such steamer, when he shall have arrived within half a mile of such curve or bend, shall give a signal by one long blast of the steam-whistle, which signal shall be answered by a similar blast, given by the pilot of any approaching steamer that may be within hearing. Should such signal be so answered by a steamer upon the farther side of such bend, then the usual signals for meeting and passing shall immediately be given and answered; but if the first alarm-signal of such pilot be not answered, he is to consider the channel clear and govern himself accordingly.

RULE VI.-The signals, by the blowing of the steam-whistle, shall be given and answered by pilots, in compliance with these rules, not only when meeting "head and head," or nearly so, but at all times when passing or meeting at a distance within half a mile of each other, and whether passing to the starboard or port.

RULE VII.-When two steamers are approaching the narrows known as "Hell Gate," on the East River, at New York, side by side, or nearly so, running in the same direction, the steamer on the right or starboard hand of the other (when approaching from the west), when they shall have arrived abreast of the north end of Blackwell's Island, shall have the right of way, and the steamer on the left or port side shall check her way and drop astern. In like case when two steamers are approaching from the east, and are abreast at Negro Point, the steamer on the right or starboard hand of the other shall have the right of way, and shall proceed on her course without interference, and the steamer on the port side of the other shall keep at a safe distance astern (not less than three lengths) until both steamers have passed through the difficult

RULE VIII.-When steamers are running in the same direction, and the pilot of the steamer which is astern shall desire to pass on the right or starboard hand of the steamer ahead, he shall give one short blast of the steam-whistle as a signal of such desire and intention, and shall put his helm to port; and the pilot of the steamer ahead shall answer by the same signal, or, if he prefer to keep on his course, he shall give two short and distinct blasts of the steam-whistle, and the boat wishing to pass must govern herself accordingly, but the boat ahead shall in no case attempt to cross her bow or crowd upon her course.

N. B.-The foregoing rules are to be complied with in all cases except when steamers are navigating in a crowded channel, or in the vicinity of wharves; under such circumstances. steamers must be run and managed with great caution, sounding the whistle, as may be necessary, to guard against collision or other accidents.

SECTION 4,233, REVISED STATUTES.-*Rule 24.* In construing and obeying these rules, due regard must be had to all dangers of navigation, and to any special circumstances which may exist in any particular case rendering a departure from them necessary in order to avoid immediate danger.

RULE IX.-All double-ended ferry-boats on lakes and seaboard shall carry a central range of clear, bright, white lights, showing all around the horizon, placed at equal altitudes forward and aft, also such side-lights as specified in section 4,233, Revised Statutes, Rule 3, paragraphs B and C.*

Local inspectors in districts having ferry-boats, shall, whenever the safety of navigation may require, designate for each line of such boats a certain light, white or colored, which shall show all around the horizon, to designate and distinguish such lines from each other, which light shall be carried on a flag-staff amidship, fifteen feet above the white range-lights.

The line dividing jurisdiction between Pilot-Rules on Western Rivers, and Lakes and Seaboard, at New Orleans, shall be the lower limits of the city.

EXTRACTS FROM REVISED STATUTES.

RULE VI. River steamers navigating waters flowing into the Gulf of Mexico, and their tributaries, shall carry the following lights, namely: One red light on the outboard side of the port smoke-pipe, and one green light on the outboard side of the starboard smoke-pipe. Such lights shall show both forward and abeam on their respective sides.

RULE VII. All coasting steam vessels, and steam vessels,

* Same as Article III. (b), International Regulations.

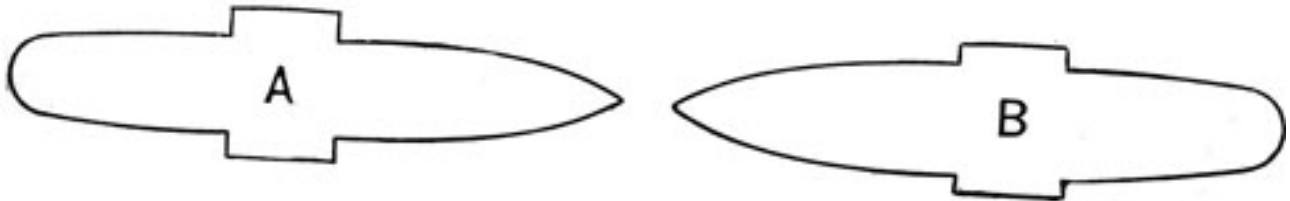
other than ferry-boats and vessels otherwise expressly provided for, navigating the bays, lakes, rivers, or other inland waters of the United States, except those mentioned in Rule VI., shall carry the red and green lights, as prescribed for ocean-going steamers; and, in addition thereto, a central range of two white lights; the after-light being carried at an elevation of at least fifteen feet above the light at the head of the vessel. The head-light shall be so constructed as to show a good light through twenty points of the compass, namely: from right ahead to two points abaft the beam on either side of the vessel; and the after-light so as to show all around the horizon. The lights for ferryboats shall be regulated by such rules as the Board of Supervising Inspectors of Steam vessels shall prescribe.

DIAGRAMS.

The following diagrams are intended to illustrate the working of the foregoing system of colored lights, and are to be used by pilots in connection with the rules, as sailing directions on meeting or nearing other steamers:

FIRST SITUATION.

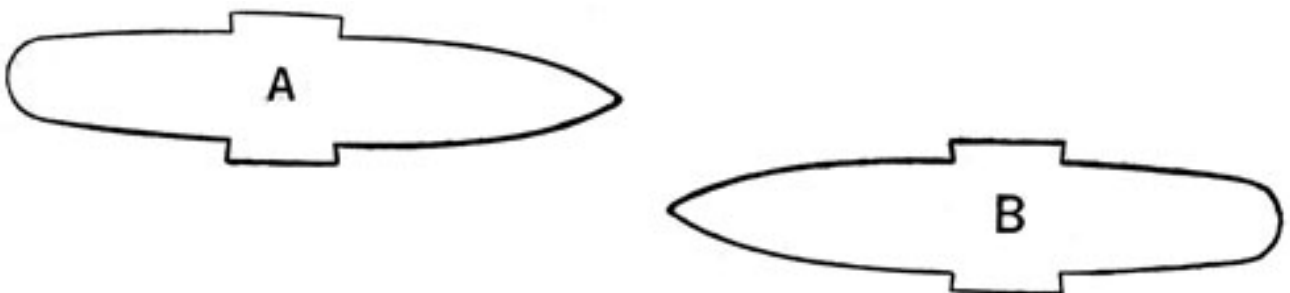
Here the two colored lights, visible to each, will indicate their direct approach (" head and head ") toward each



other. In this situation it is a standing rule that both shall put their helms to port and pass to the right, each having previously given one blast of the steam-whistle.

SECOND SITUATION.

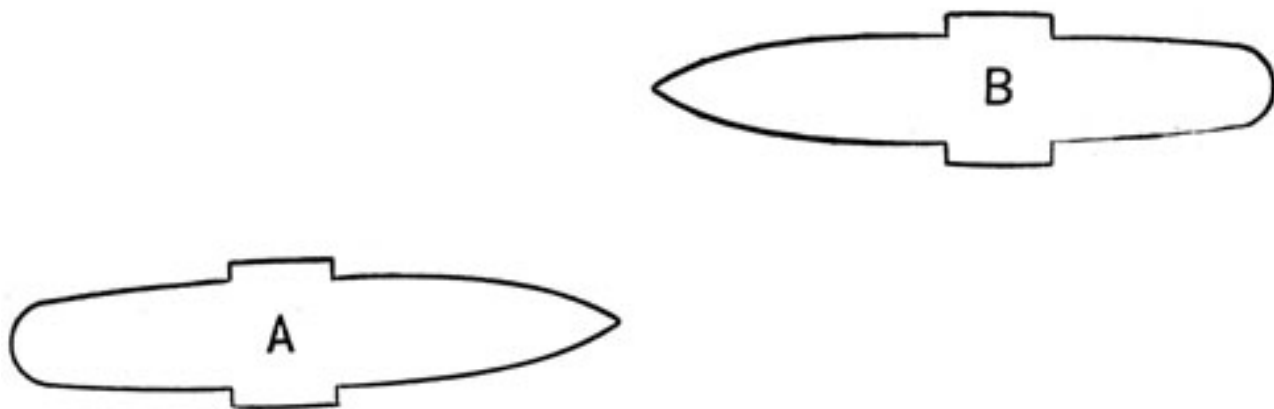
Here the green light only will be visible to each, the screens preventing the red light from being seen. They



situation, each pilot having previously signified his intention by two blasts of the steam-whistle.

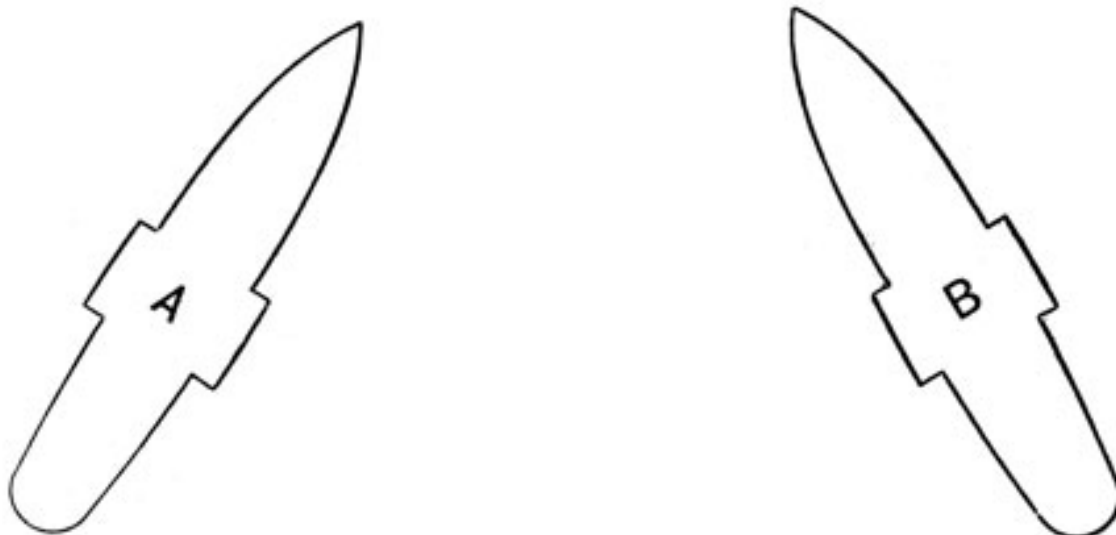
THIRD SITUATION.

A and B will see each other's red light only, the screens preventing the green lights from being seen. Both vessels are evidently passing to port, which is rulable in this situation, each pilot having previously signified his intention by one blast of the steam-whistle.



FOURTH SITUATION.

This is a situation requiring great caution; the red light of B in view to A, and the green light of A. in view to B, will inform both that they are approaching each other in an oblique direction. A should put his helm to port, and pass



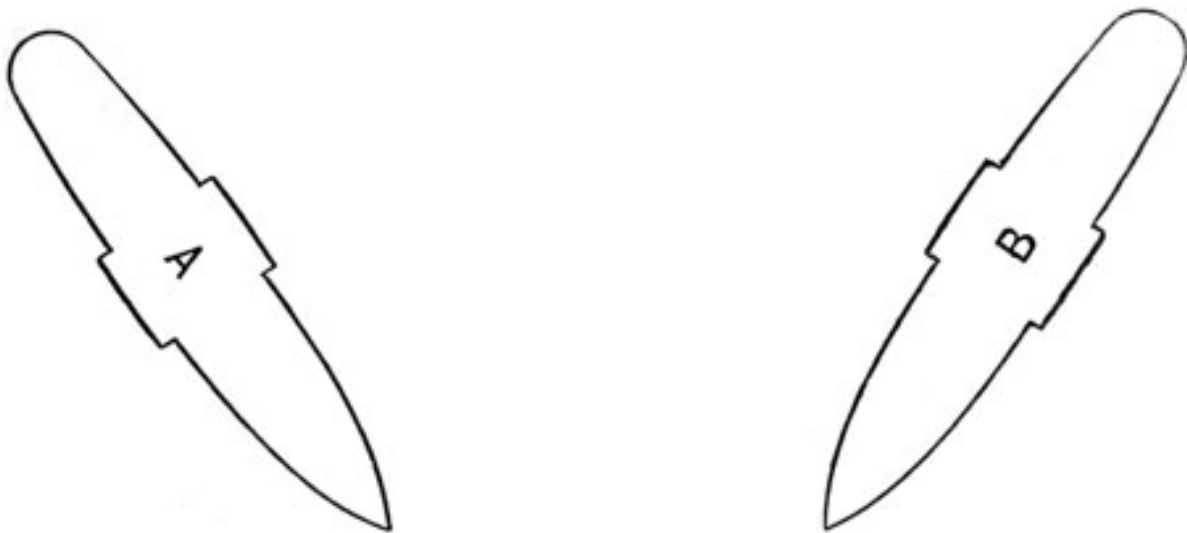
astern of B, while B should continue on his course, or port his helm, if necessary to avoid collision, each having previously given one blast of the steam-whistle, as required by the rules, when passing to the right.

FIFTH SITUATION.

This is a situation requiring great caution; the red light of A in view to B, and the green light of B in view to A,

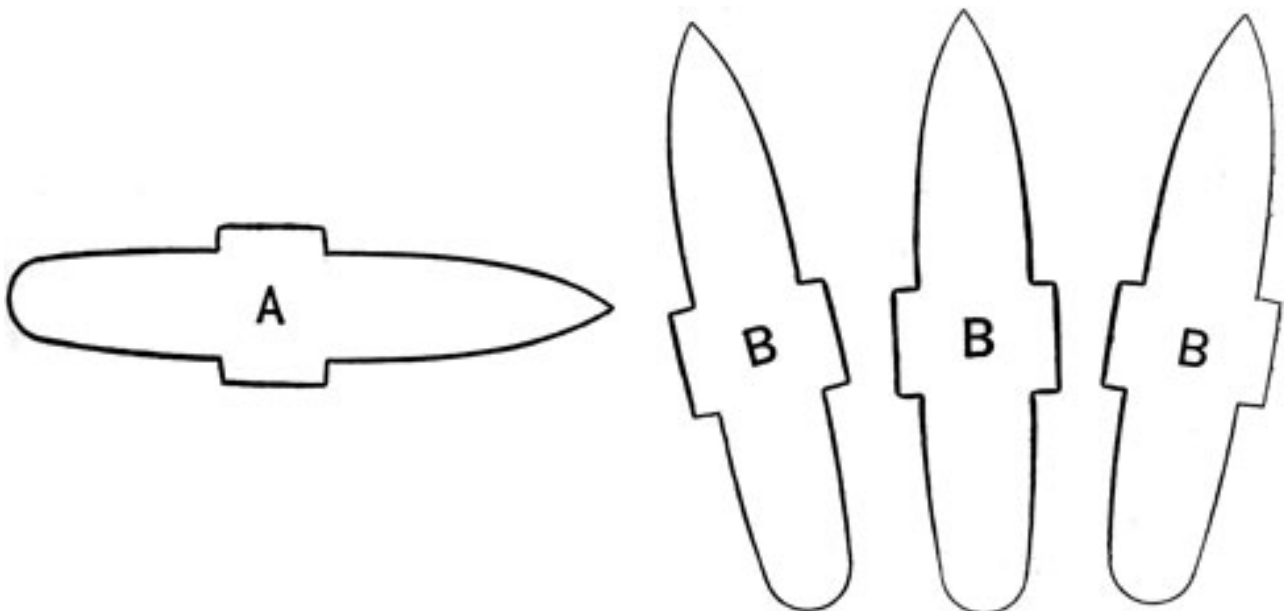
373

will inform both that they are approaching each other in an oblique direction. B should put his helm to port and pass astern of A, while A should continue on his course, or port his helm, if necessary to avoid collision, each having previously given one blast of the steam-whistle, as required by the rules when passing to the right.



SIXTH SITUATION.

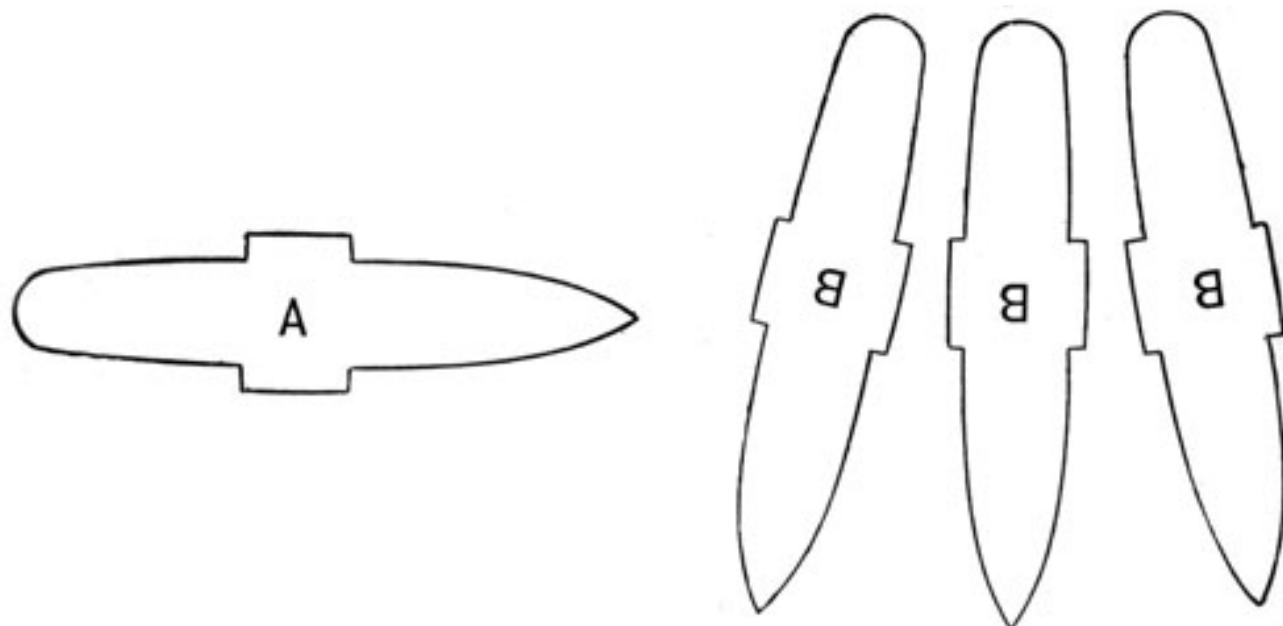
In this situation the steamer A will only see the red light of the steamer B in whichever of the three positions the latter may happen to be, because the green light will be hid from view; A will be assured that the port side of B is toward him, and that the latter is therefore crossing the bows



of A in some direction to port; A will therefore (if so near as to fear collision) port his helm with confidence, and pass clear. On the other hand, the steamer B, in either of the three positions, will see both the red and green lights of A, by which the former will know that the steamer is approaching directly toward him; B will act accordingly, and keep away if necessary.

SEVENTH SITUATION.

In this situation the steamer A will only see the green light of the steamer B, in whichever of the three positions the latter may happen to be, because the red light will be hid from view; A will be assured that the starboard side



of B is toward him, and that the latter is therefore crossing the bows of A in some direction to starboard; A will therefore (if so near as to fear collision) starboard his helm with confidence and pass clear. On the other hand, the steamer B, in either of the three positions, will see both the red and green lights of A, by which the former will know that a steamer is approaching directly toward him; B will act accordingly, and keep away if necessary.

The manner of fixing the colored lights should be particularly attended to. They will require to be fitted each with a screen of wood or canvas, on the inboard side, and close to the light, in order to prevent both being seen at the same moment from any direction but that of right ahead, each light being visible, singly, to two points abaft the beam.

This is important, for without the screens any plan of bow-lights would be ineffectual as a means of indicating the direction of steering. This will be readily understood by a reference to the preceding illustrations, where it will appear evident that in any situation in which two vessels may approach each other in the dark the colored lights will instantly indicate to both the relative course of each; that is, each will know whether the other is approaching directly or crossing the bows either to starboard or port.

This intimation, with the signals by whistle, as provided, is all that is required to enable vessels to pass each other in the darkest night with almost equal safety as in broad day. If at anchor, all vessels, without distinction, must exhibit a bright white light at least twenty feet above the surface of the water.

375

BUOYS.

ON THE COAST OF THE UNITED STATES.

In approaching the channel, &c., *from seaward*, *red buoys* with *even* numbers will be found on the *starboard* side of the channel, and must be left on the starboard hand in passing in.

In approaching the channel, &c., from seaward, *black* buoys with *odd* numbers will be found on the *port* side of the channel, and must be left on the port hand in passing in.

Buoys painted with *red and black* horizontal stripes will be found on obstructions with channel ways on either side of them, and may be left on either hand in passing in.

Buoys painted with *white and black* perpendicular stripes will be found in mid-channel, and must be passed close-to to avoid danger.

All other distinguishing marks to buoys will be in addition to the foregoing, and may be employed to mark particular spots.

Buoys to mark abrupt turning points in channels, or obstructions requiring a specific and prominent mark, may be fitted with staves surmounted by balls, cages, triangles, and other distinctive marks. Yellow buoys, without numbers, are used to mark any danger at a quarantine station.

The largest description of buoys ("mammoth" or special buoys) are to mark the approaches to channels over seaward bars and isolated shoals, rocks, or other obstructions to navigation which lie at considerable distances from the coast.

First and second class buoys are to mark the approaches to, the obstructions in, and to point out and mark the limits of channels leading to the principal harbors along the coast, and also to mark the channels and obstructions adjacent to the coast and those in the large bays and sounds.

Second and third class buoys are to mark the approaches to and the channels and obstructions of the lesser harbors, bays, &c.

Nun or can buoys liable to be damaged or swept away by floating ice are removed on the approach of freezing weather, and spar buoys put in their places. In the spring the larger buoys are replaced.

Small spar-buoys are to mark channels and obstructions in shoal-water navigation.

Different channels in the same bay, sound, river, or harbor are marked, as far as practicable, by different descriptions of buoys. Principal channels are marked by nun-buoys, secondary channels by can-buoys, and minor channels by spar-buoys. When there is but one channel,

376

nun-buoys, properly colored and numbered, are placed on the starboard side, and can-buoys on the port side of it.

Buoys are placed in the best positions to mark obstructions or define channels, and are made to float as high and as nearly upright as possible during the strongest winds and tides. White numbers, as large as the class of the buoy will admit, are painted on four sides of red and black buoys, and the other distinguishing marks made to show as prominently and at as great a distance as possible.

Vessels approaching or passing light-vessels of the United States, in thick, foggy weather, will be warned of their proximity by the alternate ringing of a bell and sounding of a fog-horn on board of the light-vessel, at intervals not exceeding five minutes. Canada is buoyed on the same system.

ENGLAND.

The side of the channel to be considered starboard or port with reference to the entrance to any port from seaward.

The entrance of channels or turning points shall be marked by spiral buoys, with or without staff and globe, or triangle, cage, &c.

Single colored can buoys, either black or red, will mark the *starboard* side, and buoys of the same shape and color, either *checkered* or *vertically striped* with white, will mark the *port* side; further distinction will be given, when required, by the use of spiral buoys, with or without staff and globe or cage, globes being on the starboard hand and cages on the port hand.

Where a middle ground exists in a channel, each end of it will be marked by a buoy of the color in use in that channel, but with horizontal rings of white, and with or without staff and diamond or triangle, as may be desirable. In case of its being of such extent as to require intermediate buoys, they will be colored as if on the sides of a channel. When required, the outer buoy will be marked by a staff and diamond, and the inner one by a staff and triangle.

Wrecks will still continue to be marked by green nun-buoys.

All buoys have their names painted on them in conspicuous letters.

IRELAND.

Harbors, rivers, and channels are marked by either *black* or *red* buoys on the *starboard* hand when entering from the sea, and on the *port* hand by buoys of the same color as those on the starboard hand,

with the addition of a *white belt*; and middle dangers are marked by *white* buoys surmounted by a *black* beacon.

377

SCOTLAND.

Entering port, &c., from seaward, *red* buoys must be left on the *starboard* hand in passing in.

Entering port, &c., from seaward, *black* buoys must be left on the *port* hand in passing in.

Buoys painted *red and black* are placed on detached dangers, and may be passed on either hand.

Fairway buoys are plainly marked. Wreck buoys are painted *green*.

All buoys have their names painted on them.

Liverpool is buoyed on the same system.

FRANCE.

On entering a channel from seaward, all buoys and beacons painted *red* with a *white* band near the summit must be left to *starboard*; those painted *black* must be left to *port*; buoys that can be left on either side are colored *red with black* horizontal bands. That part of a beacon below the level of high water and all warping buoys are colored *white*. The small rocky heads in channels are colored in the same way as the beacons when they have a surface sufficiently conspicuous.

Each buoy has upon it the name of the danger it is meant to distinguish; likewise its number, commencing from seaward. The even numbers are on the red buoys, and the odd numbers on the black buoys. The letters and numbers are white, and from ten to twelve inches in length.

All jetty heads and turrets are colored above half-tide level, and on the former a scale of metres is marked from the same level.

HOLLAND.

On entering the channel, etc., from seaward, *white* buoys must be left on the *starboard* hand, and *black* buoys on the port hand.

BELGIUM.

Same system as Holland.

REPORTS REQUIRED IN THE CASE OF A COLLISION.

In the event of a collision, the commanding officer is to furnish the department with the following information:

1st. His own report, that of the pilot, of the officer of the deck and other officers who witnessed the occurrence. The statements are to be exemplified by a diagram, and must contain the courses steered, the point at which the vessel was first seen, the time when the engine was stopped, if in motion at what speed at the moment of collision.

378

In addition are required: the direction of the wind and condition of the weather; what lookouts were placed; what lights were exhibited by both vessels; whether either vessel deviated from the rules, and whether blame attaches to any one.

Written statements and estimate of damage from the officers of the other vessel must be procured if possible; also a survey of the injury to both vessels, made by United States officers.

If the vessel is in charge of a pilot, and the collision was due to his acting in violation of the rules, the fact must be established in the report, and no pilotage paid him.

Changes suggested in Existing Rules. Several of the rules have been regarded as open to discussion, and as some of them may be modified in the near future, attention may be briefly directed to those most frequently questioned.

International Rule IX. seems especially unfortunate. The nature of the duty performed by pilot boats may bring them very close aboard when furnishing pilots, and they have no lights displayed to show the direction in which they are standing, at a time when such lights would be of the greatest use. The recent sinking of the New York pilot boat Columbia, with all hands, by the steamer Alaska, was possibly due in part to the absence of side lights on board the former.

International Rule XII. could be so modified as to replace, in a sea-way, the present meaningless sound of the whistle by a series of blasts, showing, at least approximately, the course of the ship. The whistle would then do for steamers in a fog what their side lights accomplish at night. Evidently if lights were only needed to indicate position, one light might (like the present fog-whistle) suffice for the purpose. As it is, we have *three* lights, to show approximate course, *as well* as position. For the same reason, course signals should be made by vessels in a fog. Without going into details, it may be suggested that if a steamer were furnished with two whistles (one with whistle and one with horn sound), a code of four blasts as a maximum would be sufficient to indicate every alternate point of the compass. Such signals could be made automatically.

International Rule XIX. gives certain optional whistle signals for indicating intended course, in clear weather. It is regretted that such signals were not made obligatory, and that the successful experience of years in United States waters was not sufficient to prove the value of this peculiarly American idea.

International Rule XXI. might be modified to secure right of way for large vessels in very narrow

channels where there is plenty of fairway on either side for smaller craft. At present, a very large ship of deep draft, while

moving through a narrow entrance, may be jeopardized by the stupidity or wilfulness of any coasting skipper whose craft might lay her course, and find plenty of water clear of the main channel.

A rule observed by pilots in the waters of New York harbor has the sanction of established custom. It consists in giving right of way to ferryboats about to enter their slips. This is probably because of the difficulty that such a craft would have in getting fairly pointed again for her slip, if obliged to reverse to clear a passing vessel, in the prevailing strong tides of the North and East Rivers. We are informed that this same practice is sanctioned by local custom at most United States ports where strong currents prevail.

Crossing Wheel Ropes. Officers accustomed to the usual action of wheel (and helm) in sea-going men-of-war may be reminded that the pilot laws require steam vessels navigating inland waters of the United States to arrange their steering apparatus so that the wheel goes in the same direction as the helm. This is precisely contrary to the practice in sea-going craft.

CHAPTER XXII.

GETTING UNDERWAY UNDER SAIL.

Remarks on Casting. When there is plenty of sea-room, and the wind is fair, it is best to cast under the head-sails and to make sail when before the wind.

In casting with the square sails set, ships invariably gather sternway the moment the anchor breaks ground. On this account, and under these circumstances, it is considered a good general rule (in the case of a foul wind) to cast with the head towards the nearest of the neighboring dangers, to make a stern board while the anchor is being catted, then to fill and make sail enough to insure going about in stays when requisite.

When there is not room to admit of going much astern, set the main-sail before starting the anchor, if possible, or as soon after as it will take, and have a purchase all ready to clap on the cable the moment that the anchor promises to give a heavy heave; otherwise the ship may go tripping it astern into shoaler water, and certainly will be unmanageable until it is at the bows.

As a general rule, and one not to be neglected, when weighing one anchor have the other ready for letting go, and as soon as an anchor is weighed get it ready for letting go at once.

Before getting under way, shift the helm over two or three times, to insure the rendering of the wheel ropes, and that the tiller is clear in its sweep.

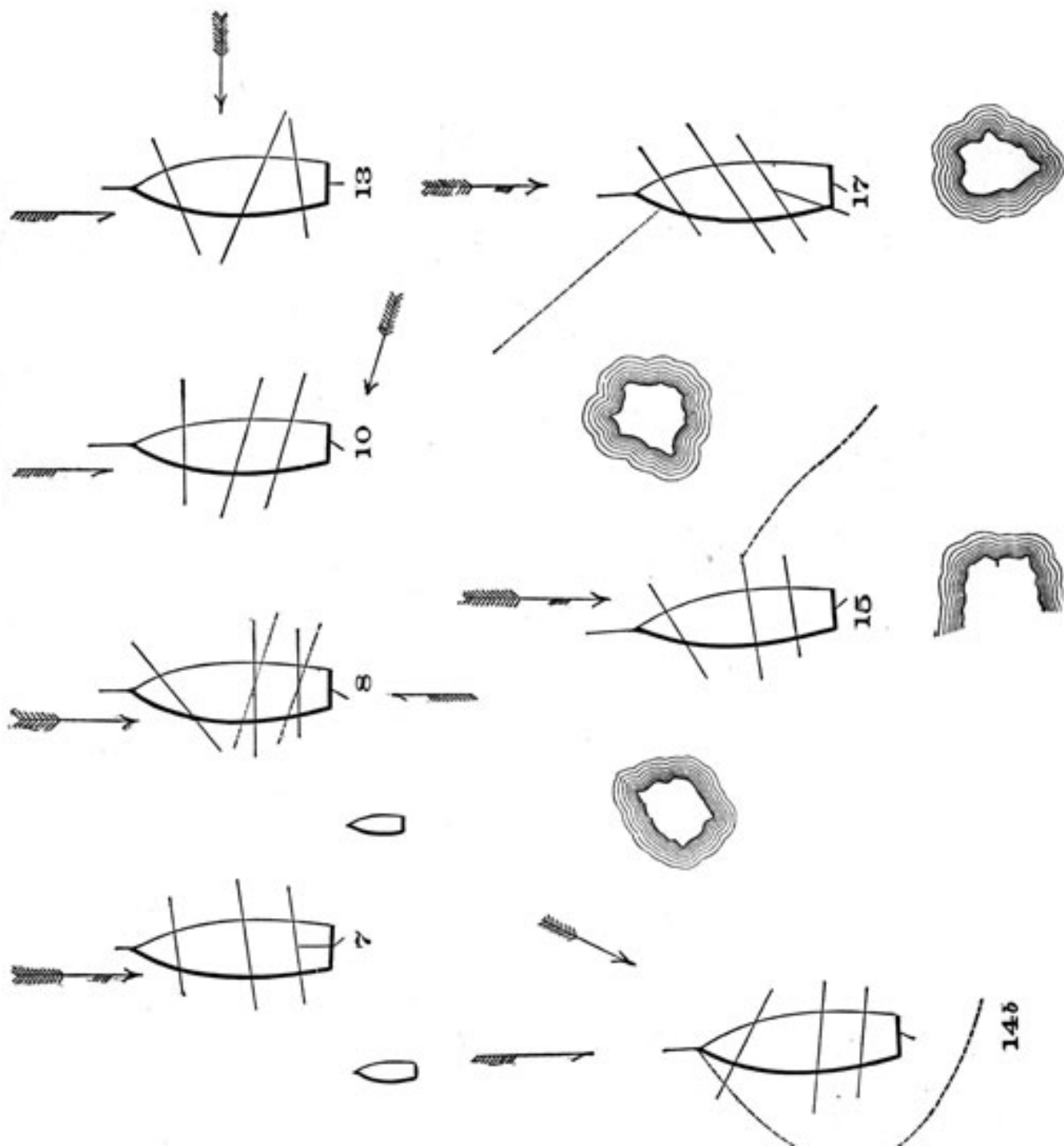
When you have room, and are pitching, it will be best to get the anchor up before making sail. By so

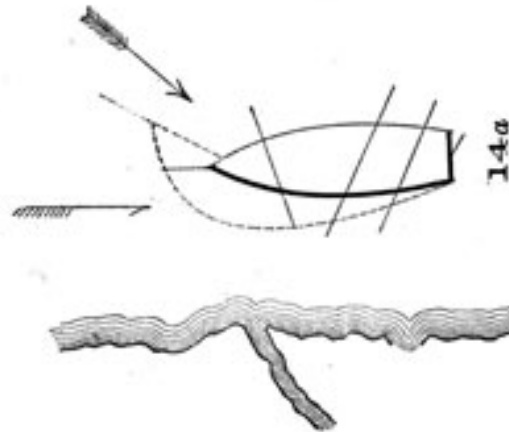
doing you will ease the chain, capstan, &c.

When about to get under way (the ship being tide rode and the wind aft), the comparative strength of wind and tide must be well considered before coming to the decision to make sail and weigh, or to weigh first and to make sail afterwards. For it does not look seamanlike to see a ship under canvas forging ahead over her anchor, tearing the copper off her bottom, and sheering unmanageably about before breaking ground; and it is equally bad management when the anchor is hove up and the ship is drifted by the tide without steerage way.

If the wind were light, it would be necessary to make

Plate 109





381

nearly all sail before breaking ground; or if moderate, merely to loose them. If it were blowing strong, the ship might stem the tide without any sail; but in this latter case it would be well to have a head-sail set, so as to prevent the possibility of breaking the sheer while stowing the anchor.

TO GET UNDER WAY AND STAND OUT ON A WIND.

(CASE 1, PLATE 109.)

Having the vessel in readiness for sea. and unmoored, prepare to get under way as under ordinary circumstances, with the wind fair for standing out of the harbor.

Rig the capstan and fish-boom, reeve the cat and fish purchases, ship the gratings, swifter the bars, call:

UP ANCHOR!

If there are two capstans, the one on the gun-deck is manned by the port watch.* The principal stations are:

Forecastlemen to clean off chain with hose, stand by with cat, fish, &c.

Mastmen see gear ready for making sail.

Quartermaster and men stationed at the wheel go to their stations; also, leadsmen in both chains or quarter boats.

Gunner's gang tend chain around capstan, fore and main topmen port watch be ready to bitt or unbitt, tend stoppers, or at controllers, &c. Master-at-arms and servants or berth-deck cooks tend berth-deck

compressors; tierers in the chain locker. Man the bars, HEAVE AROUND! and heave in the cable to a *short stay*.

As soon as "brought to," the first lieutenant orders the navigator to inform him when the chain is in to a certain scope, say fifteen fathoms chain in five fathoms water, though it depends entirely upon the strength of the wind and sea.** When in to the required scope, the navigator orders, AVAST HEAVING! and reports to the first lieutenant, who then directs the men to be sent up (supposing it a frigate) to make sail.

The cable being in to a short stay, *Heave and paul!* stopper the cable well, and unship the bars, on the spar deck.

Stations for making sail! LAY ALOFT SAIL LOOSERS! and when the men are aloft and ready, LAY OUT AND LOOSE! *Man the topsail sheets and halliards!* In the meantime the forecastle men are loosing the head sails, and the afterguard the spanker; when ready, *Stand by!* LET FALL! SHEET

* The steam capstans adopted for use in the service will modify this arrangement of stations.

** The old rule for a short stay was, that the cable should be on a line with the foretopmast stay.

382

HOME! LAY IN! LAY DOWN FROM ALOFT! The men all lay down on deck, except a few hands in the tops to light up and overhaul the rigging; at the same time, *ease* away the topsail clewlines, and haul close home the topsail sheets.* As soon as the men are clear of the yards, *Tend the braces! Haul taut!* HOIST AWAY THE TOPSAILS! giving also the cautionary order, *Light up the rigging aloft!* Hoist the topsails to a taut leech, and BELAY THE TOPSAIL HALLIARDS! or *High enough the fore! Well the mizzen!* Belay the main! &c., &c. Sheet home and hoist the topgallant sails, and then the royals, if the wind is light. Brace up the after yards for the tack on which you wish to cast, and the head yards abox to pay her off. Top up the spanker boom, and bear it over on the side you wish to cast.

The following orders are commonly used, sail being made:

Man the port head braces! Starboard main, port cross-jack braces! -or, the reverse, as you wish to cast (after part generally to after, forward part to head braces).

Let go and overhaul the lifts! Clear away all the bowlines! Tend the lee braces!

Haul taut!

BRACE UP!

BRACE ABOX!

It will be observed that the booms are not triced up when loosing to get under way.

The sails being set, *Man the bars!* ship and swifter them; HEAVE AROUND! at the same time giving her a sheer with the helm. The officer of the forecastle reports when the cable is "*up and down,*" and also when the *anchor is aweigh!* at the former report, *Man the jib and flying jib halliards!* The fore topsail pays her head off, and as soon as the head sails will take the right way, LET GO THE DOWN-HAULS, HOIST AWAY! Put the helm a-lee for sternboard, at the same time, heave the anchor up to the bows; and as soon as it is high enough, *Avast heaving! Paul the capstan!* stopper the cable; cat and fish the anchor. When she has fallen off sufficiently, RIGHT THE HELM! Brace around the head yards, and set the spanker. Trim the yards and stand out to sea, making sail as required.

As soon as the anchor is catted and fished, the navigator causes the cable to be bitted and cleared for running, and having nothing more to do in that station, repairs to his station to assist in conning the ship, or acting as pilot. Having passed the bar-buoy, and seeing that all the sails are properly set, the anchors and boats secured, and no further necessity for all hands to be on deck, the first

* With a full crew the topsail can be sheeted home and hoisted at the same time; otherwise start the halliards well up before getting the sheets close home. See page 340.

383

lieutenant reports the fact to the captain, who directs him to "pipe down." On the boatswain piping down, the officers

leave their stations and the lieutenant of the watch takes the trumpet, receiving the course from the pilot or navigator.

In some cases, though rarely, the captain gets the ship under way. When he does not, the first lieutenant does it, though the captain is still responsible for the manner in which it is done.

In getting under way in a spacious harbor, where you have sufficient room, if circumstances will admit of it, it is advisable, particularly if blowing fresh, to keep the foretop-sail to the mast until the anchor is catted and fished; to do which set the spanker as soon as, or before, she breaks ground, and keep the head sails down; or flow the jib-sheet.

Should it blow sufficiently fresh, and present appearances of heavy weather outside, it is advisable to reef the topsails while setting them.

When getting under way to stand off *on a wind*, the spanker may be set, and very often is, when sail is made; guying the boom on the lee quarter, or the side to which you cast, as this catches the vessel should she be inclined to fall off too much.

MAKING SAIL.

Making sail to royals should be done rapidly; the sheets got close home, or "home alike," and the sails hoisted up taut.

There are two ways of making sail: first, order the top-gallant and royal yardmen to "keep fast," and not let their sails fall till ordered; then, as soon as the topsail yards are mast-headed, LET FALL, SHEET HOME AND HOIST THE TOPGALLANT SAILS! and as soon as they are up, LET FALL, SHEET HOME, AND HOIST THE ROYALS! Second, as most commonly practised, let everything fall together, sheet home and hoist the topsails, and then the topgallant sails and royals in quick succession.

Before breaking ground, be sure the ship has the right sheer, or the jibs may take the wrong way and the ship fail to cast as desired.

If you cannot break ground and are apprehensive that the anchor has hooked under a rock or permanent moorings, clew up and furl, and let go the other anchor; then bring the buoy-rope in through the sheet hawse pipe, and endeavor to weigh it by that means, or get out the launch and let her weigh it. Should the buoy-rope prove unequal to the strain, send a hawser down over the buoy-rope by a

384

running bowline, catch it over the upper fluke, and weigh it by that.

A steamer can generally break her anchor out by stoppering well the cable and going ahead slowly.

TO GET UNDER WAY FROM FIXED MOORINGS.

Proceed as in the above, bracing the yards as you wish to cast, then slip the moorings and trim the yards to the course, or use a spring from the moorings if circumstances require, taking both ends of the spring inboard that you may let go one end, unreeve and haul it on board.

TO GET UNDER WAY AND STAND OUT BEFORE THE WIND. (CASE 2.)

In some cases, particularly with the wind directly out of the harbor, vessels are got under way under the jib and spanker alone, thus: having those sails loosed and ready for setting, *Man the bars!* and heave the anchor right up to the bows, giving her a sheer with the helm whichever way you wish to cast. It is always advisable, if possible, to cast *from* the anchor; that is, if heaving up the port anchor to cast to starboard; because it is easier thus hove up to the bows after it is a trip, and the cat more readily hooked. As soon as the anchor is aweigh, hoist the jib; and as she pays off, haul out the spanker. Keep her under this sail, until the anchor is catted and fished; then hard up, brail up the spanker, make sail and stand out.

LYING IN AN OPEN ROADSTEAD

BY THE STARBOARD ANCHOR, HEAD TO THE WIND, BLOWING DIRECTLY OUT-TO GET UNDER WAY IN THE SHORTEST MANNER POSSIBLE. (CASE 3.)

Having everything in readiness, "bring to" on the cable, *Man the bars! Heave taut!* off stoppers, and HEAVE AROUND! When the cable is up and down, *Clear away the jib!* put the helm to port for sternboard, and continue heaving until the anchor is up to the bows; *Paul the capstan!* Cat and fish the anchor. As soon as the anchor is aweigh, hoist the jib.

She is now paying off under the jib. As soon as she gathers headway, **SHIFT THE HELM!** *Stations for loosing sail!* **ALOFT SAIL LOOSERS! LAY OUT AND LOOSE!** *Man the topsail sheets and halliards!* When before the wind, and ready for letting fall, **RIGHT THE HELM! LET FALL,**

385

SHEET HOME! LAY IN! LAY DOWN FROM ALOFT! and **HOIST AWAY THE TOPSAILS!** *Man the topgallant and royal sheets and halliards!* **SHEET HOME AND HOIST AWAY!** Set the foresail; sheet home in quick succession the topgallant sails and royals; remembering to tend the light braces. *Haul taut the lower lifts!* keeping the lower yards square by the lifts; hook the burtons on the topsail yards, and haul them well taut; haul taut the topgallant lifts, and *Stand by to set all the studding-sails!*

RIDING HEAD TO WIND,

WITH A ROCK OR SHOAL ASTERN, AND CLOSE ABOARD-TO GET UNDER WAY AND MAKE SAIL, BY THE WIND, ON THE STAR-. BOARD TACK. (CASE 4.)

The object now is to get the vessel under way without losing anything, either in drift after the anchor is aweigh, or in falling off after casting.

Having hove in to a safe scope, run out a hawser ahead, with a kedge, from the starboard bow; and having let it go, haul the hawser well taut; masthead the topsail and topgallant yards, having the sails loosed, and only confined to the yards by the quarter gaskets; brace the yards sharp up by the port braces, fore and aft; loose the courses, jib and spanker, and have them ready for setting; the starboard jib-sheet aft, and the fore and main tacks and sheets stretched along the deck.

Man the bars and heave around briskly, until the anchor is up, taking in at the same time the slack of the hawser; cat and fish the anchor; and have it ready for letting go as soon as possible.

Man the hawser and warp the vessel ahead, sheering her with the starboard helm. Have the topsail sheets well manned, and as soon as the kedge is short apeak, or comes home, sheet home the topsails, run up the jib, haul out the spanker, with the boom on the port quarter; and as soon as the jib takes, with the wind on the starboard bow, run the kedge up to the bows.

As she falls off, and the moment the topsails take, draw the jib, set the courses and topgallant sails, and right the helm. Should the kedge come home before it is apeak, make sail immediately, hauling in the hawser at the same time.

If she is falling off rapidly when the topsails take, set the spanker and mainsail alone, easing off the jib-sheet; and as she comes to, board the fore tack, haul aft the jib-sheet, and meet her with the helm.

If, when the kedge is aweigh, she should fall off to starboard, and bring the wind on the port bow, let go the anchor and bring her up. By this process you have warped

considerably ahead of the anchorage, and by counter bracing the head yards you may get under way, as under ordinary circumstances, or you may run out the kedge again, and make a second trial.

If, while warping ahead, the kedge comes home, or the hawser parts, proceed at once to make sail or let go the anchor.

**ANCHORED ON A LEE SHORE,
TO GET UNDER WAY AND STAND OFF. (CASE 5.)**

When close to a lee shore, with too much wind or sea to get the anchor easily, or when you cannot afford to go astern, the ship must be cast with a spring, and the anchor abandoned. Thus, supposing that the ship is riding by the starboard anchor, and that it is determined to cast to port, brace the yards up on the starboard tack, have the sails ready for setting, with the number of reefs in that may be necessary; hoist the topsail yards sufficiently high for setting the topsails, and cast as many gaskets off as can be spared. Pass one end of a buoy-rope in through the riding cable hawse-hole, and make it fast to that cable forward of the bitts, stopping it along to the cable at intervals to prevent fouling, put a buoy on the outer end, and hang it outside all to the bumpkin. If riding with nearly a whole cable out, prepare to disconnect its end from the slip in the locker, drive the shackle-pins out and see the cable clear for running. If riding with only part of a cable out, you may be able to disconnect further up, and thereby save so much chain; but it would not be prudent to unshackle until the ship is sure of going the right way, for a flaw of wind might bring her to, after having gone off to port a certain number of points. and it would then be necessary to hold on for another trial. In such case, unusual strain would be brought on the cable fastenings, and if they carried away or rendered, and the cable were unshackled, you would be adrift; but were it still connected, it would bring you up.

Pass the end of a hawser from the starboard quarter outside all, and make it fast for a spring to the riding cable at the hawse-hole; haul it taut, make fast and have an axe ready for cutting it. Haul the head sheets aft on the starboard side. Be all ready to loose and make sail and veer cable. Put the helm a starboard, and when the ship's head is sheering to port, hoist the head sails, veer away cable, and put the helm amidships; when the head sails have taken well and the ship is evidently swinging from her quarter by the spring, disconnect the cable, warning the people to stand clear of the end, and let go the buoy. Set the courses and then the topsails, if not able to set all at

once; and when the wind is *well on the starboard beam* (and not sooner, otherwise the ship will fly into the wind before she has steerage way enough to keep her out of it), cut the spring, trim the head sails, and when you have good way on, bring her gradually to the wind.

GETTING UNDER WAY IN A TIDEWAY.

In the foregoing examples, we have had nothing to consider, in getting under way, but the effect of the sails and helm on the vessel; but in a tideway, we have also the force of the current to guard against, or profit by, during the operation.

Definition of Tides. A *windward tide*, is when the wind and tide are contrary.

A *leeward tide*, is when the wind and tide are together. A windward ebb, is when the tide is setting out, and the wind blowing in.

A *windward flood*, is when the tide is setting in, and the wind blowing out.

A *leeward ebb*, is when the tide and wind are both setting out.

A *leeward flood*, is when the wind and tide are both setting in.

A *spring tide* is the highest tide, and occurs just subsequent to the *full* and *change* of the moon.

A *neap tide* is the lowest tide, occurring when the moon is near the *first* and *third* quarters.

Lying at anchor in a tideway, a vessel will ride to the wind or tide whichever is the stronger; and whatever influence the rudder has upon her movements, caused by the resistance which either side of it presents to the force of the water against it (which will act upon the stern of the vessel until checked by the cable, in proportion to the velocity of the current), that effect will evidently be the same, whether she is forced through the water by the sails or by other means; or being stationary, if the water rushes past her.

RIDING HEAD TO WIND AND TIDE,

TO GET UNDER WAY, CASTING TO PORT, AND STAND OUT ON THE STARBOARD TACK.

(CASE 6, PLATE 109.)

Heave short, keeping the helm a-starboard, which (the tide acting on the port side of the rudder), will bring the wind a little on the starboard bow. Set the topsails; brace the after yards up by the port, and the head yards by the starboard braces; have the jib and spanker ready for setting; man the bars and heave the anchor up to the bows. The moment the anchor is aweigh, hoist the jib; and the moment she has paid off sufficiently (which she will) to

port, brace around the head yards. If she gathers stern-way before the head yards fill, shift the helm; and then proceed as in former evolutions.

TO BACK ASTERN. (CASE 7, PLATE 109.)

If you have not room to cast, either to port or starboard, from your anchorage-suppose a vessel on each quarter-weigh the anchor, and drift down between the vessels before you cast, thus:

Heave short; set the topsails and spanker; brace all the yards about halfway up by the port braces; then heave in on the cable, and as soon as the anchor is aweigh, put the helm to port; the tide acting against the starboard side of the rudder, casts the stern to port; the sails being aback, she will soon gather sternboard, when the effect of the tide upon the rudder will be lost; but the resistance by stern-board on the port side of the rudder and the effect of the spanker will counteract the tendency of the fore topsail to pay her off. In this manner let her drift down with the tide, between the two vessels. Should she pay off too much you may bear the spanker boom well over to windward, and brace the mizzen topsail sharp up. Should she, in sternboard, be in danger of fouling the one vessel, she will increase the distance from the other, when you may brail up the spanker, shiver the after yards, hoist the jib, and let her go around before the wind, righting the helm as she gathers headway.

In like manner a vessel may be backed astern where there is no tide.

But this manoeuvre should not be attempted except with a smart working ship, as a sluggish vessel or one that takes a rank sheer, will be likely to foul one of the two dangers before any change in the disposition of canvas will affect her movements. Therefore, with an ordinary cruising vessel, getting under way under sail, proceed as follows:

Heave short; set the topsails, reefed if necessary, and keep the yards square; the helm amidships. Heave in again, and when she breaks ground and starts astern, paul the capstan and stopper the cable. You may thus club down, and when clear of danger heave up briskly, wear and make sail as requisite.

For instances of CLUBBING, see Appendix I.

**WIND-RODE, WITH A WEATHER TIDE,
TO WEIGH ANCHOR, CAST TO STARBOARD, AND GET BEFORE THE WIND IN THE
SHORTEST MANNER POSSIBLE. (CASE 8, PLATE 109.)**

Heave short; set the topsails and loose the jib; brace the head yards sharp up by the port braces; and leave the

after yards square; man the bars and heave around; the moment the anchor is away put the helm to starboard; as soon as the jib will take hoist it, heaving the anchor up at the same time; as soon as the after yards take, square the head yards; and, as she gathers headway, shift the helm; when before the wind, right the helm, cat and fish the anchor, and make sail on your course.

By the above arrangement of sail, the ship will get a rank sternboard, particularly if blowing fresh, and cut a broad sheer before gathering headway. This may be avoided as follows: brace the after yards about halfway up by the starboard braces, taking care to have the port after braces manned, so that they may be squared in again as she pays off; when, proceed as before. It is necessary to the perfect success of this evolution that the main and mizzen topsail *should be kept shivering* until the yards are square.

The latter method is only necessary when getting under way from a close berth. If blowing very fresh and no room to spare, the yards may be mast-headed and the *fore-topsail alone* sheeted home; which, with the jibs, will pay her off with little sternboard; when before the wind, make sail.

**TIDE-RODE, WIND TWO POINTS ON STARBOARD BOW,
TO GET UNDER WAY, CASTING TO STARBOARD. (CASE 9.)**

Heave short, keeping the helm to port, which, from the effect of the tide upon the starboard side of the rudder, will bring her head to wind. Set the topsails, bracing up the after yards by the starboard and the head yards by the port braces; set the spanker and bear the boom well over on the starboard quarter; have the jib loosed and ready for setting, with the port sheet aft. In this position, the vessel will not remain steady, but will come up and fall off; man the bars, and heave up-and-down; and, as she comes head to wind, weigh the anchor and hoist the jib, still keeping the helm to port; the head sails, and the effect of the tide upon the rudder before she gathers sternboard, will pay her head off to starboard. The moment she gathers sternboard, shift the helm; as she falls off, having the wind on the port bow, shift over the head sheets, brail up the spanker, if necessary, and proceed as before directed in filling away and making sail.

Should she not pay off to starboard the moment the anchor is aweigh, owing to her not being head to wind; or should she, by the force of the tide on the port quarter, and wind on the after sails, be kept from falling off sufficiently to fill the head yards, it will be necessary to veer cable and

390

bring her up, when the evolution may be performed with a spring from the port quarter.

See also Club-hauling, Chapter XXIV.

**RIDING TO AN EBB TIDE,
WITH THE WIND ON THE STARBOARD QUARTER-TO GET UNDER WAY AND MAKE SAIL
ON THE PORT TACK, NOT HAVING ROOM TO MAKE THE FIRST STRETCH ON THE
STARBOARD TACK. (CASE 10, PLATE 109.)**

Set the topsails when the anchor is at a short stay, leaving the head yards square, and bracing the after yards up by the starboard braces. The moment the anchor is aweigh, put the helm hard a-starboard. The

fore topsail being full will give her headway, which may be increased by letting fall the foresail, and hauling it aboard; and the starboard helm will pay her head around to port, hauling out the spanker as it will take; which, with the after yards, will bring her to the wind, bracing up the head yards as she comes to, and meeting her with the helm.

RIDING TO A WINDWARD TIDE, WIND AFT.

TO GET UNDER WAY AND STAND OUT BEFORE THE WIND. (CASE 11.)

Make every preparation for weighing, heave in, loose the jib, heave up the anchor, run up the jib; cat and fish the anchor and make all sail.

If in a crowded harbor, narrow channel, or where it would be necessary to have the ship under immediate command, proceed as follows: Suppose the ship to be riding by the port cable, heave short, loose and make sail, sheer her with the port helm and bring the wind on the starboard quarter; brace the yards up by the starboard braces and keep them shivering by the helm. Heave up, fill the after and square the head yards; haul aft the starboard jib sheet; cat and fish the anchor; up helm; fill the head and shiver the after yards, getting the ship before the wind, when make sail.

RIDING TO A WINDWARD TIDE, WIND AFT.

TO GET UNDER WAY AND STAND OUT ON A WIND. (CASE 12.)

Make the usual preparations and commence heaving in; loose the jib and spanker; (riding by the port cable as before and wishing to cast on the starboard tack) top up

391

and bear the spanker boom on the port quarter and put the helm apart; heave up and haul out the spanker as soon as it will take. When the wind gets abeam, run up the jib and meet her with the helm; cat and fish the anchor; loose, sheet home and hoist the topsails, brace up, bring by, and make sail.

EBB TIDE-WIND ATHWART. (CASE 13, PLATE 109.)

Heave short, loose sail, and set the topsails; fill the fore and mizzen and leave the main square. Then heave up; cat and fish the anchor, keeping the ship hove to, and either tack or wear. Tacking or wearing will, however, depend on circumstances, and the amount of room to windward or to leeward.

If to tack-hoist the jib, fill away the main topsail, haul out the spanker, and set topgallant sails, &c.

If to wear-hoist the jib, up helm, shiver the after sails, &c.

If she does not lie steady with the main yard square, brace it sharp aback, as in the figure.

WEIGHING FROM A LEE SHORE,

SHIP RIDING TO THE COAST CURRENT. (CASE 14, PLATE 109.)

A vessel has rode out a gale on a lee shore; it is desirable to weigh and stand off; but a strong current sets along the land, and the wind blows in on the off-shore bow, as indicated by the arrows in the cut. Under these circumstances there may be two methods of getting under way.

Case 14 *a* represents the position of the ship riding by the starboard cable. Make the accustomed preparations, and heave in to a short scope without tripping. Bend a spring from the port quarter to the cable; haul it taut and secure it well. Have a slip-rope around the spring from the port bow to insure its not being carried under the forefoot by the weight of the chain. Make sail to topsails, mainsail and spanker-bracing the after yards sharp up by the starboard braces, and the head yards abox, or rather pointed to the wind. Put the helm hard aport; stream the buoy; slip the cable; the spring will bring the chain on the other how, and cast the ship to starboard. When it will take, hoist the jib, right the helm, slip the spring, and trim the head yards, as necessary.

Case 14 *b*, in which the position of the ship is again illustrated. Here, in lieu of slipping and using the spring, the anchor is hove up, and the ship backed off, by putting the helm to starboard, instead of port, as in the previous case, while the head yards are braced sharp abox, and the after

392

ones kept nearly square. In this case, the mainsail is not used, and the foresail set to help the ship's head pay off to port. When sternway commences, the helm is shifted to port, the after yards trimmed sharp by the starboard braces, spanker and mainsail set, when they will take, &c., &c.

RIDING TO LEE TIDE.

DANGER ASTERN, AND ON EACH BEAM. (CASE 15, PLATE 109.)

Heave short without tripping, loose sail, and set the fore-topsail and fore-topgallant sail; lead along the halliards of all the head sails, as also the fore tack and sheet, and brace the head yards sharp up by the port braces.

Mast-head the after yards, keeping them square, and stopping the sails up with rope-yarns. Put the helm hard aport, heave up briskly, trip the anchor, let fall the foresail, hoist the jib, with the sheets to windward, and wear short round on the ship's heel, shifting the helm when necessary. When before the wind, check the port head braces, make after-sail, and stand out with the wind on the quarter.

NOTE. Have an anchor ready to let go in case the ship should cast the wrong way; and observe to give her a rank sheer with the port helm, *before* the anchor breaks ground, hoisting the head sails as soon as the vessel's head passes the direction of the wind.

WIND AND TIDE CONTRARY.

SHIP ATHWART THE STREAM. (CASE 16.)

If to get *before* the wind, square the after and brace abox the head yards. Heave up the anchor, and when the fore-topsail shivers, square the head yards.

If to make sail *by* the wind, brace sharp up the after yards, square the head ones—heave up the anchor, and when the ship comes to, brace up forward.

STRONG WIND AND LEE TIDE.
WITH A SHOAL ASTERN. (CASE 17, PLATE 109.)

With regard to the manner of executing this manoeuvre, there seems to be a difference of opinion among seamen; it is, however, generally conceded, that the following method is the most certain and secure:

Heave in to a short scope, and make sail to single-reefed topsails; lead along the tacks and sheets, jib-halliards, and

393

spanker out-haul, and brace the yards up as sharp as possible by the *port* braces, and put the helm hard a-starboard. As soon as the anchor is aweigh, let fall the courses, set the spanker, meet the ship with the helm, and hoist the jib.

NOTE. This supposes the case of casting to *port*. If to starboard, reverse the yards, and put the helm the contrary way.

TO STAND OUT WITH A FREE WIND,
PASSING BETWEEN TWO SHIPS ANCHORED CLOSE ABOARD. (CASE 18.)

The usual preparations having been made, the topsail yards mast-headed and sails stopped up, heave in to a short stay and let go the stream anchor, the hawser coming in, through the after chain pipe or warping chock; heave up the bower and let the ship wind round and ride by the stream. Heave up the stream, sheet home the topsails, drop the foresail, &c., &c.

This may also be done in a narrow channel, when, by the usual method, there is risk of backing ashore; or a steamer may be thus winded and pointed fair for going out of a small harbor.

MAKING SAIL FROM A SPRING LAID OUT BY ANOTHER VESSEL.

On one occasion, in 1831, in order to save a French merchant brig from being wrecked, Capt. Harding ventured to anchor the *Jaseur* in the narrow and dangerous pass of Tamatave (Madagascar), in very squally and unsettled weather. We* dropped anchor in the brig's hawse about a cable and a half to windward, and immediately veered about seventy or eighty fathoms of cable; at the same time, we ran the end of the stream cable out to her, and a lieutenant was sent with all the boats to her assistance.

On getting on board, he found, from the short and broken sea then running, that it would be impossible to heave the vessel ahead without great risk to both vessels; under these circumstances he took the following method: He made a spring of the *Jaseur's* stream cable on the port side, all the yards were braced up for the port tack, the pinnace was made fast to the stream cable, a sufficient number of men sent aloft to have the topsails and courses ready to let fall at a moment's notice; when everything was quite ready for cutting

the cable and spring, and making sail at the same time, the spring was then tautened, so as to bring the wind well on the port bow; the moment she had sheered sufficiently

* Captain Liardet, R. N.

394

for the sails to stand well, all sail was set together, and as soon as she felt her canvas, the cable and spring were cut at the same instant. As she was cast to seaward, the press of canvas she was under appeared to bury her in the very surf, but she was lifted, gathered way, and just grazed clear of the reef.

For handling a vessel under sail in a tideway, see Appendix I.

Remarks on Weighing. It must be remembered, that a ship which has to *wear* in getting under way, will seldom readily pay off until the anchor is close up to the bow. Therefore, under such circumstances, heave up as briskly as possible.

If a ship has a leading wind and is anchored in a narrow channel. or in the midst of a number of vessels, she would be got under way before the *weather tide* is done, as it would be extremely difficult to cast her upon the lee tide.

Should it blow fresh upon the windward tide, so as to force her "end on" over her cable, it would be impossible to heave it in without sheering her over from side to side, and heaving in briskly as the ship slacks her cable; but as this would be attended with considerable danger by the sudden bringing up of the ship upon each sheer, it would be prudent to heave apeak upon the first setting of the windward tide, and before the ship swings, to bring the wind aft.

The Kedge and Toggle. When using a spring the weighing of the kedge may be much facilitated by bending the hawser to the crown of the anchor, and securing it to the ring by means of a squilgee toggle. If the anchor has been carried out by a boat let her hang on to the buoy, and at a signal from the ship pull out the toggle, when the kedge may be run up to the quarter, and when the ship finds room she will heave to and pick up the boat.

CHAPTER XXIII.

THE DECK.-MAKING AND TAKING IN SAIL.

On getting clear of the harbor, the first lieutenant causes everything about the decks to be secured for sea; the boatswain, upon receiving the order, secures the anchors, and, if a long passage is anticipated, the chains are unbent and the hawse-bucklers put in. If the chains are not unbent the hawse-pipes are closed by means of *jackasses* (canvas bags stuffed with oakum). The chains after being cleaned are paid below. Dry and stow away everything used in getting under way.

If the vessel be under sail alone, the anchors and chains are kept ready for use until a good offing is made.

On piping down from getting under way the first lieutenant turns the deck over to the officer having the watch, who is at once to acquaint himself with the position of the ship, her condition, and all orders remaining to be executed.

Before losing sight of the land, the navigator takes the departure, puts over the patent log and sets the course, when the officer of the deck will commence heaving the log and marking the log-book. The chafing gear will now be put on, the boats topped up and secured, and the studding-sail gear will be rove, if not done before leaving port.

The Officer of the Deck. An outline of the daily routine at sea will be found in the internal rules and regulations of the ship, but a few minor details may be here mentioned. Let it be supposed that an officer is called at 3:50 A.M. to keep the morning watch. Ten minutes is the usual time allowed for him to reach the deck. Having received all the orders, information, &c., he will, on the watch being reported up, and the wheel and lookouts relieved, "relieve the watch," and have the watch on deck mustered. In the meanwhile he "passes the course" to the man at the wheel, looks at the compass if going free or under steam, or at the sails if "full and by," and this he should frequently repeat during the watch. After the mustering of the watch it is well to make a rapid survey of the deck, to see that the yards and sheets are properly trimmed, weather lifts and weather braces taut; lights burning brightly, lookouts properly stationed, and to give any cautionary orders to the officer of the fore-castle he

may deem expedient, such as to have the topgallant clew-lines led along, and keep a bright lookout ahead.

Except when making such inspections, or when obliged to satisfy himself personally of any fact, the officer of the deck should make it a rule to *stay at his proper station*, on the bridge or horse-block. He should observe this rule, especially when giving orders, instead of rushing about, as is too often the case, to assist in carrying out his own commands.

The captain of each part of the ship should be supplied with a list of his men. Petty officers may generally be relied upon to muster their own parts and to report absentees, if there are no junior officers available for this duty.

The very great advantage of calling the watch ten or fifteen minutes before eight bells, giving the men time to prepare for their watch, and to be mustered before the time for relieving, may be here reiterated (see Organization, p. 305). It would add to the health and comfort of the crew, to the safety of the ship when under sail, and relieve the mind of the officer of the deck of the anxiety felt during that painful interregnum when neither watch feel it incumbent to "man the main clew-garnets and buntlines," let it look never so squally to windward.

The habit cannot be too earnestly recommended to the young watch officer of anticipating various emergencies and casualties, such as a man falling overboard, parting rigging, &c., &c., and determining what should be done in each event, when it does occur, the right order may burst involuntarily from the lips, and the mind be fully prepared for the necessary evolution.

The orders of the executive officer in reference to washing clothes or scrubbing decks, called "morning orders," and usually written in an order book, are put in execution immediately after mustering the watch, unless trimming yards, or other essential duties, or want of light prevent. If clothes are to be washed, the command is given to "*lay up the rigging fore and aft*" and "*sweep down*," and the boatswain's mate is ordered to call the "watch scrub and wash clothes." A certain time should be allowed for washing-not over an hour-and the clothes should be neatly stopped on the lines so as to lap, each piece, by an inch or two, the white and blue separate, the former always being above or on a different set of lines, that they may not be soiled by the dripping of the latter.

At sunrise the order is given, *Lay in, deck lookouts! Lay aloft to the masthead!* The lights are taken in, forward officers called, and the master-at-arms directed to turn out and report up the idlers.

The mates of the decks get their orders from the officer of the deck. If the main deck is to be washed, the second

397

part of the watch is sent below. But if under sail, an officer should be cautious not to allow the watch to become so much engaged, or the running rigging so encumbered, that the sails may not be readily handled, or the yards braced in any sudden emergency.

At six bells the boatswain will be directed to "call all hands and pipe the hammocks up," after which get all the sheets home and sails taut up.

If on a wind, proceed as follows:

Get a jigger on the main tack, slacking the weather lift and lee brace, and the sheet if necessary. Then haul taut the lift and brace, haul aft the sheet. Now get jiggers on the weather, then the lee topsail sheet, getting them home alike; overhauling well the clew-lines and reef-tackles, slacking the halliards and tending the topgallant sheets. Then clap on to the topsail halliards, heaving off the lee brace and tending the weather one and the topgallant sheets. Get the topsail up to a taut leech, then haul home the topgallant sheets, pull up on the halliards-always attending the braces and the sheets of the sail next above, and then get the royal sheets close home and the sail up taut. Proceed similarly on the fore and mizzen, haul the heads of the fore-and-aft sails chock out, and then the sheet or foot out-haul aft.

See the head-sails hoisted with a taut luff, and trim aft the sheets.

If free, with studding-sails set, get the lower studding-sail halliards up, then trim the out-haul. With the other studding-sails, get the tacks boom-ended, halliards chock up and sheets trimmed, in the order named.

In trimming studding-sails, if the tack of the sail will not reach the boom end when the halliards are up, the boom has probably been rigged too far out.

The sails being trimmed, put the tops to rights, hammock cloths and boom cover smoothed over and

stopped down, bright-work cleaned, chains swept out, peajackets put in the bags and stowed away, and rain clothes hung on the jackstays between the launches.

An officer should never leave anything to be done by his relief which he should have performed himself.

At sunset the command is given, *Station deck lookouts!* and *Lay down from the mast-head!*-the side lights are lighted and placed in position, in the light-boxes. Send aloft the masthead light if under steam.

Half an hour before each meal the ship's cook makes his report at the mast; before breakfast and supper that "tea-water is ready for serving out," and at 11:30 brings the dinner for inspection. If nothing has occurred to interfere with the regular meal hours he is ordered to *serve out*.

Everything affecting the health and comfort of the crew should receive the earnest attention of the officers. There

398

are minor points of duty which no rules or regulations can reach, and which must be left to the thoughtfulness and good sense of the officers themselves. Thus a considerate officer will anticipate a rain-squall, and get washed clothes or scrubbed hammocks down in good time. He will not commence an all-hands job fifteen minutes before twelve o'clock, and send the men down to dinner at one bell. Boats and working parties will be recalled in time for their meals; timely preparation will be made for rain that the men may not be exposed to it unnecessarily, and a dry place reserved for the watch below.

MAKING AND TAKING IN SAIL.

Young officers should make themselves familiar with the lead of the running rigging, and where it belays, and on first getting to sea, it is well to exercise the crew at manning the ropes, that they may learn their lead and be enabled to find them on the darkest night.

To Set a Foresail, give the order

Man the fore tack and sheet!

At this command the men jump to their stations, the fore-tack and sheet are manned, one hand being by each clew-garnet, and the buntlines and leechlines let go.

Lay down on the fore yard and overhaul the rigging!

At this order, one or two of the topmen lay down, and overhaul, through their blocks, the buntlines and leech-lines.

If the weather is moderate, as soon as the officer of the deck sees that the men are at the stations, he orders-

Clear away the rigging! HAUL ABOARD!

At this the clew-garnets are let go, the tack hauled forward, and the sheet aft.

The Mainsail is set in the same manner, substituting *main* for *fore*; and to get the tack close down, it is advisable, if the yard is braced sharp up, to ease off the lee main brace,* and overhaul the weather clew-garnet, weather main-topsail clewline and main lift. After the tack is down, brace up the yard, haul taut the lift; reeve and haul the bowline.

When the yards are square, and the wind directly aft, the mainsail is never set, but is hauled up snugly; with the wind quartering, the lee clew may be set to great advantage. To do so, *Man the main sheet! Overhaul the main buntlines and leechlines!* When ready:

Ease down the lee clew-garnet! HAUL AFT!

The weather clew is kept fast.

* Not applicable to the fore, as the brace has more of a horizontal lead.

399

To set the Foresail before the wind.

Man both fore sheets!

The rigging being let go and overhauled as before, order

DOWN FORESAIL! As the sail comes down, take through the slack of the tacks; haul taut both lifts, haul through the slack of the sheets.

To set the Courses (by the wind), order-

Man the fore and main tacks and sheets!

Lay down on the lower yards to overhaul the rigging!

When the gear is reported all manned-

Haul taut! Clear away the rigging! HAUL ABOARD!

To take in a Course in moderate weather. If a foresail, order, *Man the fore clew-garnets and buntlines!* The clew-garnets and buntlines being manned, men stationed at the tack, sheet, and bowline, order-

Haul taut! UP FORESAIL!

The tack, sheet, and bowline, are let go, the clews of the sail are run up by the clew-garnets, the body by the buntlines; man the leechlines and haul the leeches to the yard.

In a fresh breeze, or gale of wind, it is necessary, in order to avoid shaking or flapping the sail, which may split it, to proceed thus: If you wish to set a course, the yard being braced up, everything being manned, order-

Ease down the lee clew-garnet! HAUL AFT!

Then when the clew is sufficiently aft to fill the sail-

Ease down the weather clew-garnet! HAUL ABOARD!

To take it in, under similar circumstances, the men being stationed, order, *Ease off the fore-tack and bowline!* HAUL UP TO WINDWARD! Then, *Ease off the sheet!* HAUL UP TO LEEWARD! Having the buntlines well manned, run them up the moment the sheet is started; the lee clew being the first set, and the last taken in, steadies the sail during the operation.*

Setting the mainsail when bracing up, it is better to get the tack down before the lee brace is near the sharp-up mark.

On setting courses by the wind, before hauling aboard, check the lee braces, for the bunt of the sails may nip or be jammed between the yard and the stay, and at all events, the main tack will come down better.

Topsails are the first sail set in getting under way, when cruising under sail, and the last taken in, in coming to anchor, except the spanker. At sea they remain constantly set, are reduced by reefing, in fresh winds, but never taken in except in gales of wind, or for the purpose

* In taking in a course, blowing fresh, haul taut the lee lift before starting the tack.

400

of repairing or unbending. The mizzen topsail is an exception, inasmuch as it is often settled down on the cap or furled, when sailing with the wind directly aft, and often taken in in heavy weather, when the fore and main are close reefed.

To set a Topsail. The yard being square and on the cap, order

Stand by to lay aloft, sail-loosens of the fore (main or mizzen) top-sail! LAY ALOFT! When the men are aloft, LAY OUT AND LOOSE!

The top-gallant studding-sail booms need not be triced up. The men lay out on the yard, and loose the sail by casting off the gaskets. While doing which

Man the topsail sheets and halliards! Tend the braces!

The clew lines are tended and buntlines let go, and overhauled aloft, the gaskets cast off, the bunt-jigger unhooked, and the men on the yard holding up the sail by hand, it is reported ready. The sheets being well manned, the order is given, *Stand by!* LET FALL! SHEET HOME! LAY IN! LAY DOWN FROM ALOFT! The clews of the sail are hauled out to the lower yard-arms by the sheets, until the foot of the sail is taut, hands *easing* away the clewlines as the sheets go home.* Meanwhile:

HOIST AWAY THE TOPSAIL!

The yard is hoisted by the halliards, until the leeches of the sail are taut, keeping the topsail reef tackles, topgallant sheets and studding sail tacks, and the topsail clewlines and topmast studding sail halliards well overhauled.

To take in a Topsail, as in coming to anchor. *Man the topsail clew jiggers and buntlines! Weather braces!* At this order, the clew-jiggers and buntlines are manned; hands stationed by the sheets, halliards, bowlines, and braces; the latter for the purpose of squaring the yards if braced up; have a hand on each lower yard-arm to render the sheets through their sheaves; order, *Clear away the topsail sheets*, CLEW UP! The clews are hauled up by the clew-jiggers, and the body by the buntlines; when the sail is up, and the weather braces manned, *Settle away the topsail halliards!* SQUARE AWAY! The yard is now lowered on the cap and squared in at the same time, the buntlines and clew-jiggers are kept some distance above the yard.

Clew Catchers are sometimes used. They consist of travelers, variously fitted, which go around the lower lift and secure to the clew of the topsail. Such an arrangement may be useful when the topsail sheets are known to be much worn and easily parted. But a sound topsail sheet will only carry away in bad weather; then, the

* In setting the light sails, the men are ordered in before sheeting home, to avoid accidents due to the motion of the yards, which have considerable play.

In heavy weather, or whenever there are men on the lower yards, it would be well to observe the same rule in sheeting home the topsails.

clew-catcher, if fitted, may travel up the lift a certain distance, and by making a span of it, bring a violent strain on the lower yard-arm. Many of our best officers object to the use of clew-catchers at any time, as tending only to save a sail at the risk of carrying away a lower yard.

To Set a Close-Reefed Topsail. Brace up the topsail yard sufficiently, and the lower yard more than the topsail yard. Haul taut the lee topsail brace, then having loosed and let fall, *Man the topsail sheets!* Attend the gear, let go and overhaul the buntlines, *Ease down the lee clewline,* HAUL HOME THE LEE SHEET! keeping the vessel off if necessary; then, *Ease down the weather clewline!* HAUL HOME THE WEATHER SHEET! Man the halliards and sway the yard clear of the cap. Trim the yards, haul taut the weather-brace and haul the bowline.*

To Take in a Topsail in a Gale. Say the fore: *Man the fore-topsail clewlines and buntlines, weather fore-topsail brace!* The weather clewline is manned best; hands by the lee brace, sheets, and halliards; when ready, keep the ship off a point, ease off a fathom of the lee sheet, *Settle away the halliards!* BRACE IN AND CLEW DOWN! Ease away the weather sheet! CLEW UP TO WINDWARD! The weather clewline and both buntlines are run up; *Ease away the lee sheet!* CLEW UP TO LEEWARD! The weather brace is hauled in when the yard is clewed down. Point the yard to the wind, steady it well, and furl the sail.

To take in a close-reefed topsail with the wind *abaft the beam,* haul up the lee clewline first; brace the yard in by the weather brace until it is pointed to the wind, if possible, before laying out to furl.

In taking it in *before the wind,* with the watch, haul up one clew at a time, hauling up *both* buntlines as before; brace the yard sharp up and shiver the sail; then lay out and furl it.

In furling a sail in a gale, secure the yard well before sending the men out; and when out, render them all the assistance possible with the *helm.*

To Take in and Furl the Mizzen Topsail in a Gale. *Man the mizzen-topsail clewlines and buntlines, lee mizzen topsail brace!* Hands by the sheets and halliards, weather brace and bowline. When ready, *Settle away the halliards!* CLEW DOWN! Hauling in on the lee brace; Ease away the sheets! CLEW UP! The yard is pointed to the wind, and the gear hauled close up; *Lay aloft all the mizzen topmen!*

LAY OUT AND FURL THE MIZZEN TOPSAIL!

To Set a Topgallant-sail. Order, *Lay aloft and loose the fore (main or mizzen) topgallant sail!* Man the

* In all cases of hoisting a square sail attend the sheets of the sail next above.

topgallant sheets and halliards! While the sail loosers are loosing the sail, the sheets and the halliards are manned, hands being by the clewlines and braces. Overhaul the royal sheets and topgallant studding sail halliards. When ready, *Stand by!* LET FALL! *Lay in!* LAY DOWN FROM ALOFT! SHEET HOME! While hauling home the sheets, if on the wind, brace up the yard sufficiently to shake the sail; take a turn with the weather brace, and let go the lee one. If before the wind, let go both braces; and if the wind is quartering, the lee one. *Tend the braces!* HOIST AWAY! Hoist the sail up to a taut leech. BELAY THE HALLIARDS! Trim the yard to the wind, set taut the weather brace, keeping the lee one a little slack.

To Take in a Topgallant-sail. *Lay aloft to furl the fore (main or mizzen) topgallant sail! Man the: fore topgallant clewlines! Weather fore-topgallant brace,* When the clewlines and weather brace are manned, hands by the sheets, halliards and lee brace; if in a moderate breeze, order, *Haul taut!* IN FORE-TOPGALLANT SAIL! The sail is clewed up, halliards let go, buntline hauled up, and the yard braced in at the same time. In a fresh breeze, order-

Round in the weather brace! Ease away the lee sheet and halliards! CLEW DOWN! Let go the weather sheet! CLEW UP! If the wind is aft, or on the quarter, order, *Let go the halliards! CLEW DOWN! Let go the sheets! CLEW UP!* Squaring the yard as it comes down by the braces, and starting the sheets when down. The sail being clewed up, steady the yard by the braces, and then order, LAY OUT AND FURL!

The three topgallant-sails are set and taken in, in the same manner, giving the order, *Lay aloft and loose the topgallant sails! and Man the topgallant clewlines, &c., &c.*

In taking in a topgallant-sail in a fresh breeze, ease the lee sheet, but do not let it go until the yard is well started in and down. This will keep the yard from cockbilling and. make it easier to clew down. But have the lee clew hauled up before the weather sheet is started.

To Set or Take in the Royals. Proceed as with the topgallant-sails, in moderate weather. The flying jib generally goes with the royals, and the following are the orders:

Aloft and loose the royals! Clear away the flying-jib!

When ready-

LET FALL, SHEET HOME! HOIST AWAY THE ROYALS AND FLYING-JIB!

To take them in, *Aloft to furl the royals! Man the royal clewlines, flying jib downhaul! Haul taut!* IN ROYALS, DOWN FLYING-JIB! FURL THE ROYALS! STOW THE FLYING-JIB!

If the royals have been kept on too long, handle them in

taking in precisely as described for the topgallant-sail, keeping fast the weather sheet until the yard is down and the lee clew hauled up. As the royal has no buntline to control the body of the sail, lay the yard for furling so as to spill the sail, being careful not to let it get flat aback, otherwise it will be blown under the foot-rope and make it difficult to lay out on the yard.

When the flying-jib is taken in under similar circumstances, let go the halliards, but do not start the sheet till the sail is about half way down, then keep easing off till the sail is down, otherwise it is likely to be split. Do not haul over the weather sheet until the sail is nearly stowed and the men on the boom are ready to receive the clew.

To Set a Head Sail. The manner of setting and taking in all the head sails is the same. To set the jib give the order, *Clear away the jib! Man the halliards!* Have a hand by the downhaul to clear it away, and, in case of the fore-topmast staysail or jib, send a hand out to light up the hanks. When ready, *Let go the downhaul!* HOIST AWAY! When up taut, trim the sheet.

In setting a *jib*, the sheet should not be kept taut, but eased, to let the sail go up; and observe, at the conclusion, that both the stay and the guys are taut.

To Take it In. *Man the jib downhaul!* Have a hand at the halliards and sheets. When manned, *Mind your weather helm!* (if blowing fresh), *Let go the halliards!* HAUL DOWN! By easing off the sheet as the halliards are let go, the pressure of the hanks on the stay is relieved, and the sail comes down easily. LAY OUT AND STOW THE JIB! When stowed, take in the slack of the halliards and sheets.

The Spanker, being at one extremity of the lever, governs the vessel more or less in all the evolutions. It serves to bring her to the wind, or to prevent her from falling off; is always set at sea, except with the wind aft or well on the quarter; and in coming to anchor, is the last sail taken in, as it is used to bring the vessel up head to wind, after the topsails are clewed up.

In Setting the Spanker, top the boom up by both topping-lifts (if two are used), after which overhaul the lee one. *Man the spanker outhauls!* Have hands by the clew-rope, head-downhaul and brails, and hands aloft to overhaul them. *Let go the brails!* HAUL OUT! Slack the weather yang, and trim the sheet.

To Take it In. *Man the spanker brails! Bead downhaul!* Have the lee brails well manned, and hands to take in the slack of the weather ones; and hands by the outhauls. *Let go the outhauls!* BRAIL UP! At the same time, haul up the clew rope, haul the boom amidships and crotch it, or in wearing, haul it over on the weather

quarter, ready for the other tack; steady the gaff by the weather vang.

To Set a Spanker or Trysail Blowing Fresh. *Clear away the spanker!* When the furling line is cast off, *Man the foot outhaul!* *Clear away the brails,* HAUL OUT! easing away the clewrope and brails. Having steadied the foot of the sail, *Man the head outhaul!* *Clear away the downhaul,* HAUL OUT! easing off the weather vang. Then trim aft the foot outhaul.

To Take it In when blowing. *Man the head downhaul and brails!* Lee brails best. *Clear away the head outhaul!* BRAIL UP! checking the foot outhaul if necessary. When the head is down, ease away the foot outhaul and brail up snug. The wind being now out of the sail, the brails may be slacked enough to haul up the clew. Steady the gaff and boom amidships.

A trysail is handled in a similar way.

Staysails. Set between the fore and main masts, are the main topmast and topgallant staysails; the first is stowed, when not set, under the fore-top, and the other in or above the fore-top.

There may be also mizzen topmast and topgallant staysails.

They are set like the head-sails, the sheets leading down on deck, and belayed in the lee gangway.

These sails are only used in light weather, with the wind free. They are termed *lifting sails*.

Studding, or Steering Sails, in light or moderate weather, with the wind free or aft, are used with great advantage, to increase the speed of a vessel. The weather topmast and topgallant studding-sails may be set with the wind one point free, or forming an angle of seven points with the keel. The lower studding-sail can only be used to advantage with the wind abaft the beam. With the wind aft and yards square, studding sails are set on both sides. The topgallant studding sail is generally set first.

The Topgallant Studding-sail. At sea, this sail is kept in the top, stowed up and down in the topmast rigging. To set it, order

Stand by to set the - topgallant stun'-sail!

Haul taut the topgallant lift.* One of the quarter-watch repairs to the topsail yard, where he converts the boom tricing-line into an "in-and-out jigger," and toggles the heel of the boom to a bull's-eye, which traverses on the jack-stay fitted for the purpose, or there may be a quarter-strap. (See Rigging Ship, p. 138.)

* It is observed that the support thus obtained is trifling. If, through neglect, the lift is not overhauled again after the studding-sail has been taken in, the yard itself will be endangered if the topgallant sail has to come in quickly.

The sail is cast loose in the top, having only a squilgee strap around it. Fig. 474. The halliards manned on deck, and the tack in the top, a hand by the sheet, and one also on the yard to assist to rig out the boom.

Haul taut! RIG OUT! HOIST AWAY!

When the boom is sufficiently out (which will be known by the mark on it), the heel is secured, keeping it on the right slue for the tack. As the sail goes up, the topmen take in the slack of the tack. When it is above the topsail yard, out squilgee, haul out the tack, run up the halliards and finally trim down the sheet.

To Take it In. Order, *Stand by to take in the topgallant stun'sail!* Man the sheet and downhaul, have a hand by the halliards, by the tack, and on the topsail yard to rig in the boom; order, *Lower away!* HAUL DOWN! RIG IN! Let the topmen rouse the sail well abaft the topgallant sail, keep fast the tack while you lower the halliards, or the sail will fly forward of the topgallant sail, and render the operation more difficult. When the sail is in, take the jigger off the topgallant lift, if used.

The fore and main are generally set and taken in together.

A topgallant studding-sail is fitted with a downhaul bent to the inner end of the yard, and leading down into the top; by this it may be easily hauled down in taking in, and dipped forward when necessary.

The Topmast Studding-sail. To set it, order, *Stand by to set the topmast stun'sail!* Get a burton on the topsail yard and haul it well taut; the upper block of the burton being generally taken to the topmast cap to give a better angle of support; get the sail out, and make up ready for sending aloft; overhaul down and bend on the halliards and tack; have one squilgee strap around the sail, and another around the halliards and outer yard-arm, to keep it up and down in hoisting; hook the in-and-out jigger on the lower yard for rigging out the boom. Having the gear manned-

Set taut! RIG OUT! HOIST AWAY!

When the sail is high enough above the yard to clear the brace, *out squilgee!* As it is run up to the topsail yard-arm, take in the slack of the tack and light the downhaul over the brace-block. Haul the tack close out, hoist the sail up taut, in the top trim the short sheet and dip the downhaul and deck sheet. As soon as the boom is out, its heel is lashed to the fore yard, and the in-and-out jigger shifted for rigging in.

In-and-out Jigger. A gun-tackle purchase is used thus: To rig out, the outer tail-block is secured to the neck of the boom-iron, the inner one to the heel of the studding-sail boom; the fall is rove through a leading block, and then down on deck. In shifting it to rig in the

boom, shift the inner block to the slings of the yard, and the other to the heel of the boom, fall leading as before.

To take in the Topmast Studding-sail. Order, *Man the topmast stun'-sail downhaul!* or, *Stand by to take in, &c.* Man the downhaul, deck-sheet, in-and-out jigger; and have hands by the halliards, tack, and short sheet in the top.

Lower away! HAUL DOWN, RIG IN! Lower away the halliards, and haul the sail down to the boom by the down-haul; then let go the tack and haul down on the downhaul and sheet together, rigging in the boom at the same time. *Take the burton off the topsail yard!* Make up the sail, hitch the halliards to the clew of the topsail; stop the bights of the tack, boom-brace and lower studding-sail halliards to, the pacific iron; having the tack *over* the fore brace. Stop in the gear along the fore yard, thence down the swifter, bights at the slings of the yard triced up by a tricing line.

The downhaul and sheets are made up with the sail.

A fore topmast studding-sail is often carried when running before a fresh breeze, such as would reduce a ship to double-reefed topsails if close-hauled; in which case the boom should be well supported. In large vessels there is a brace to the boom, but, in addition, to take the upward strain, the lower studding-sail halliards are used as a *jumper*, thus: Toggle them above the boom, bring the standing part down, and set it up securely in line with the boom. This acts as a martingale.

A main topmast studding-sail is carried, in some vessels, with the wind abaft the beam, and has great effect in increasing the speed. It is set and taken in like the fore.

In some vessels the topmast studding-sail tack is brought in along the yard, and the boom brace fitted with a short pendant and whip purchase, which is thought to be a proper method for a large vessel, having only the brace to attend to in trimming the yard; but generally the brace and tack are rove through the sheaves of a double-block in the main rigging, and both belayed close together.

To set a Lower Studding-sail. Order, *Stand by to set the starboard (or port) lower stun'-sail!* Get it out and make it up for setting; overhaul down the outer and inner halliards, and bend them on, the former to the yard, and the latter to the inner head-earring of the sail; overhaul in and bend on the outhaul to the clew; pass a stop around the sail, and secure it by a double squilgee, the tripping-line from it leading in on deck.* Haul well taut the

* The tripping-line for the topmast stun'-sail squilgee also leads on deck, that for the topgallant stun'-sail in the top. These are single. See Fig. 475, Plate 110.

Fig. 474



Fig. 475

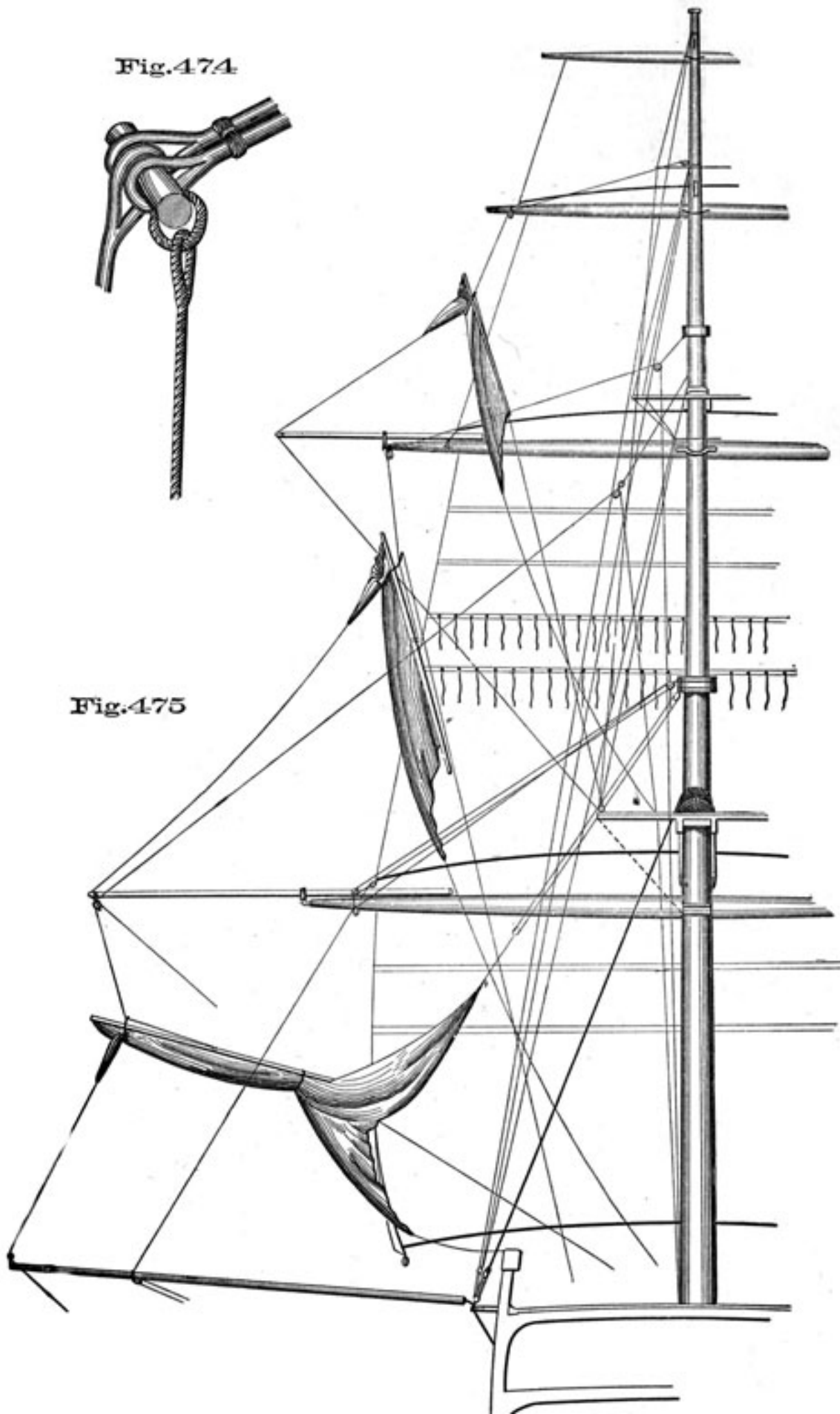
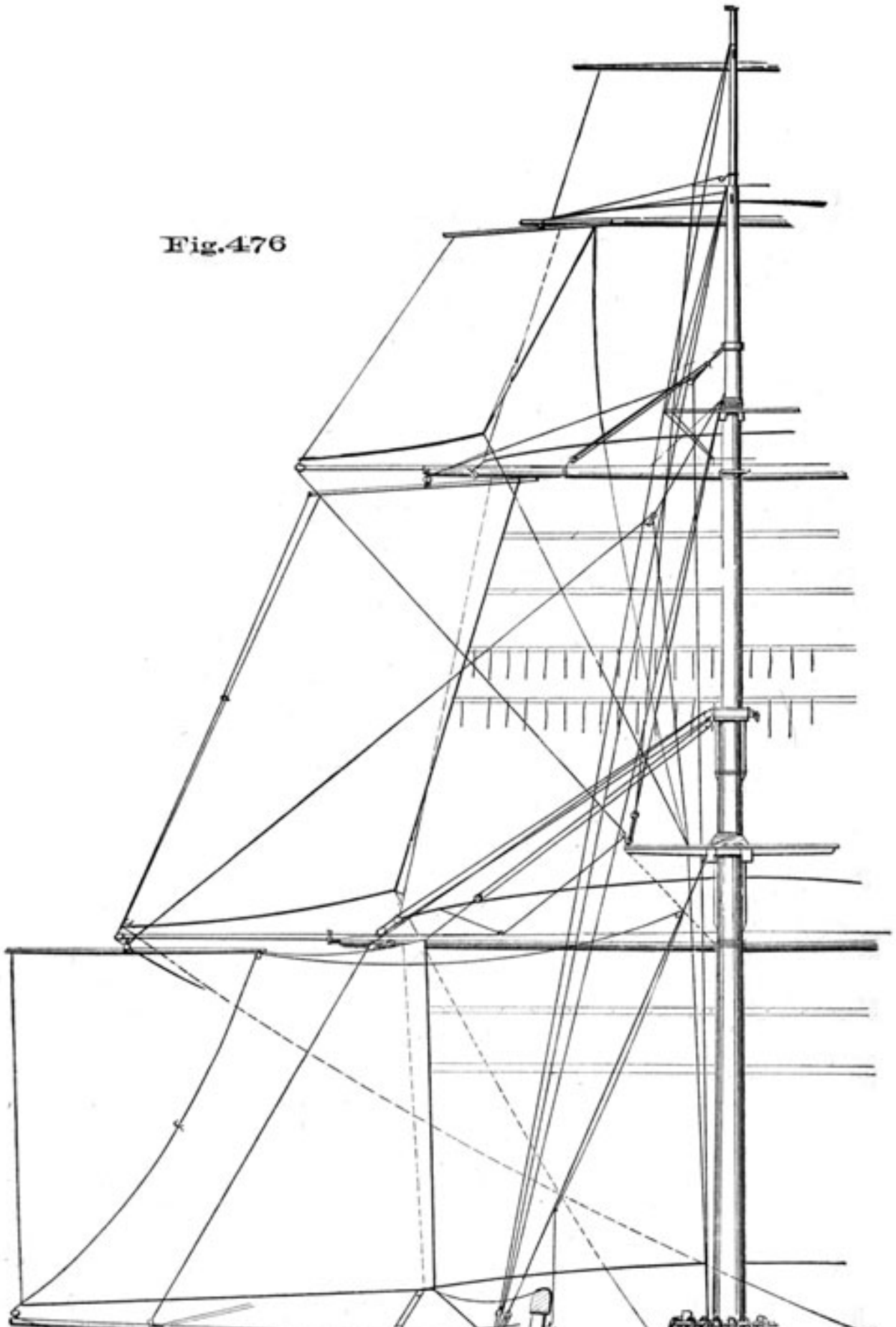


Plate III

Fig. 476



fore lift and brace. Man the lower boom topping-lift, and forward guy, and have a hand by the after guy. Pull well up on the inner halliards. Top up the boom, and at the order, RIG OUT! haul forward on the forward guy, and at the same time have everything manned for setting the sail.

Haul taut! HOIST AWAY, HAUL OUT! taking in the slack of the outhaul and inner halliards. When halfway up between the deck and lower yard, haul out the squilgee, and as the sail falls, haul out on the outhaul, and hoist the sail up taut to the topmast studding-sail boom; then haul out the outhaul and pull up on the inner halliards. Reeve the sheet through a thimble or block on the goose-neck of the lower boom, and haul it well taut. The lower boom is trimmed by the fore yard, so that the sail may set, as nearly as possible, parallel with the foresail.

To take In, order, *Stand by to take in the lower stun'-sail!* Man the clewline, sheets, and inner halliards, have hands by the outer halliards and outhaul, *Ease away the outhaul!* CLEW UP! The outhaul being let go, the clew is hauled up to the yard; then, *Lower away*, HAUL IN! Ease off the outer halliards, and haul in on the inner halliards, sheet, and clewline. When the sail is inboard and over the forecastle, *Lower away the inner halliards!* The sail being down, make it up. To get the lower boom alongside: *Man the after guy! Tend topping lift and forward guy! Set taut!* HAUL AFT! get the boom in its place and trice up the gear.

To Set all the Studding-sails on One Side. Order-

Get the starboard (or port) stun'-sails ready for setting!

Preparations are made as described, with the addition of topping up the lower boom ready for rigging out. When the officer of the forecastle reports-

"All ready forward, sir!" order

Set taut!

RIG OUT! SWAY TO HAND!

At this order the booms are rigged out together; the topgallant studding-sails swayed aloft and just clear of the topsail brace-blocks, the topmast studding-sail above the fore brace-block, and the inner halliards of the lower studding-sail pulled well up. The men then shorten in on the halliards, when order

Haul taut! HOIST AWAY! Fig. 475. OUT SQUILGEES!

The tacks are hauled close out and the halliards taut up. Fig. 476.

To Take them In.

Stand by to take in all the starboard (or port) stun'-sails!

When all is reported ready

Haul taut! Ease away the out-haul! CLEW UP! LOWER AWAY!

408

At this, the lower studding-sail is clewed up, the topmast studding-sail boom-ended, and the topgallant studding-sail started, but their tacks kept fast.

HAUL DOWN! RIG IN!

The sails and booms all come in together.

If studding-sails are to be set on both sides, at the same time, have all hands called to "make sail," and order, *Starboard watch, starboard side; Port watch, port side!* Then order, *Stand by to set stun'-sails both sides!* and proceed as in setting on one side, taking care that the yards are square, and the lifts, burtons, and braces, well taut.

Handling Studding-Sails. In setting studding-sails in a strong breeze, if you can keep the ship away until they are becalmed, you will get them up and well set when the gear would not otherwise stand.

In bracing forward, studding-sail tacks, boom braces, jumper and topping-lifts require careful attention.

In bracing in, unless the boom brace be manned, the chances will be in favor of the boom going anywhere but in a line with the yard.

Preparatory to setting studding-sails, let the topgallant clewline be hauled taut, that the man who goes out on the topsail-yard may have something to hold on to; and in hoisting the *lower* studding-sail, be careful that the yard is not brought up with a *jerk* against the topmast studding-sail boom, as by the neglect of this point, the boom is often sprung. After the sail is set, the topping-lift should be slacked sufficiently to bring the outer leech taut.

Topgallant Studding-Sails. In setting a lee topgallant studding-sail forward of the sails, in lieu of stopping the halliards to the upper yard-arm (which is the *outer* one), bring them down to the lower yard-arm, so that in hoisting, the sails will capsize over, as it were, and bring the extremity, to which the halliards are stopped, uppermost. Sway higher, out squilgee and let the men on the topsail-yard cant the yard forward, which under these circumstances, may be readily done without getting foul. If the sail

should be already set, and it is desirable to "dip" it forward, lower it about halfway down, ease off the tack, and let the man on the topsail-yard get hold of the outer leech. In this way the inner yard-arm is immediately canted clear of the topgallant sail.

But unless all the gear of a topgallant studding-sail is dipped forward with it, it will be awkward to handle when required to come in quickly, and the dipping is therefore not recommended.

In taking in topgallant studding-sails, ease away on the halliards and haul down the downhaul, keeping fast the tack until the yard is well inside the leech of the topgallant sail, when you may ease off the tack, and by hauling down on the sheet and downhaul, the sail comes in without difficulty.

409

For should the tack be started first, the sail flies forward of the topgallant sail and causes much trouble.

Topmast Studding-sails. In hauling down, ease away the tack *just* before the outer arm of the yard touches the boom end; and if the tack jams, which is not unfrequent, rig in the boom at once. The leverage is great, and boom-irons are frequently broken in this way.

In dipping the main-topmast studding-sail before the sail, the wind will be just enough on the opposite quarter to glance off the topsail and blow the inner leech aft. If the course can be altered, the sail may readily be handled, otherwise the short way is to haul down, stop the bowline in on the main yard, and set the studding-sail before all.

Lower Studding-sails. Whenever the lower studding-sail has been carried with the yards much forward, get a good pull of the after-guy before starting anything, else the lower boom will fly forward when the outhaul is let go.

Should the lower boom get under the bows, and the topmast studding-sail boom be in, put the lower halliards with a bowline knot round the lower boom, and haul them out with the lower outhaul; then, with these and the topping-lift from the fore yard, it may be got up. If not, secure the heel, disconnect the goose-neck, and whip the spar up heel foremost.

Of course, if the ship can be kept away, and the fore-yard braced in, all will be easier.

The operation of taking in a lower studding-sail may be greatly facilitated by giving the ship a sufficiency of *weather* helm to "touch" the inner leech. *Luffing* under such circumstances might be attended with loss of booms.

When the jib is drawing (excepting possibly in a ship with great drift from the head booms to the foremast), the lower studding-sail cannot be doing any good service.

Other Sails. There are a few other sails, such as a *gaff-topsail*, which sets over the spanker; a *ring-tail*, which sets abaft the spanker; a *save-all*, under the lower studding-sail boom, and a *jib-topsail*, which sets flying over the jib. These are never met with in the service now, except the *gaff-topsail*, which is

occasionally set on board the schooner-rigged gunboats, or in vessels bark-rigged.

Square Sails, &c. In loosing a sail, whether it be blowing fresh or not, the yard-arm and outer gaskets should be cast off *first*, for otherwise the weight of the bunt would jamb them, and render cutting necessary to get them clear.

In taking in a *topsail*, the weather sheet is started first, to prevent the sail from flapping, of which there would be danger if it were taken in the opposite way. This rule applies equally to *courses*, as the belly of the sail thus blows up against the stays, and is prevented from splitting.

410

Remember that the lee lower lift should be hauled well taut before starting the tack, lest the sudden upward spring of the weather yard-arm should endanger the lee leech of the topsail, and instead of letting go, *ease* the bowline off handsomely with the tack.

In setting either *courses* or *topsails*, in blowing weather, the rule seems to be invariable in reference to sheeting home to leeward first—the reason for which is to prevent the sails from flapping; and if the wind is quartering, the yard should be well braced in before the sails are set.

In *hoisting sails*, from a royal to a close-reefed topsail, the *lee* brace ought invariably to be let go, and the weather one tended. As the latter is eased away, and the sail hoisted, the yard will cant of itself, till the leech is taut, which is the indication of the sail being up. If everything is clear, there will be no necessity for hauling in the lee brace while hoisting.

In taking in a *royal* or *topgallant* sail, the lee sheet is started first and clewed up to spill the sail; for when blowing fresh, if the contrary practice was adopted the yard would probably fly fore-and-aft, part the brace and risk the mast, which is of far more consequence than the sail. The weather sheet must be eased off after the yard is clewed down, which can be done better by hauling in on the weather brace at the same time. Lay the yard and keep the sail well spilled with the helm until the gaskets are passed.

If before the wind, keep both sheets fast until the yard is down; then clew up and brace by.

The parrels of these yards are generally slack, and the yards should be bound when possible, against the rigging, by bracing in.

A royal carried too long before, or a studding-sail carried too long near the wind, cannot do the least good. If the "trimmer" is consulted while carrying a press of lofty sail before the wind, the ship will be found to be excessively out of trim by the head. Near the wind, the topgallant studding-sail is fore-and-aft, bellying to leeward, and taking the wind out of the topgallant sail.

In conclusion, the following general principle of handling sails may be stated:

In taking in a sail of any kind, endeavor to spill it; the more wind it holds the harder it will be to manage.

Letting go a lee sheet spills any sail, but in resorting to this method, in a fresh breeze, the sail may be split, and the larger the sail the more dangerous it is to allow of its shaking.

To relieve a ship *quickly* in case of danger, the lee sheet must of course be let go, even at the expense of the sail; but where it is not a question of danger, and the object is to obtain prompt and complete control of a sail, there is a

411

powerful agent available for the purpose of becalming canvas, and thus securing its easy management. This agent is the *helm*, which is often more useful than any clewlines or buntlines, and more efficacious than any number of extra hands.

With the wind *forward of the beam*, for instance, taking in any square sail from a course to a royal is rendered much easier by a few spokes of *lee helm*. Similarly with the wind abaft the beam, a topmast or lower stun'-sail is handled with comparative ease if becalmed by a like amount of *weather helm*.

In all cases of making or taking in sail, remember the importance of looking out for the gear *tended*, as well as for that which is manned.

CHAPTER XXIV.

WORKING TO WINDWARD.

STEERING-TACKING - MISSING STAYS - WEARING -BOX-HAULING - WEARING SHORT ROUND-CLUB-HAULING, ETC.

STEERING.

In general a ship, trimming by the head, carries a taut weather helm. If, on the contrary, she is too much by the stern, she will carry a lee or slack helm.

When by the wind, a tremulous motion in the cloths of the mainsail will always indicate that the ship is then at the desired point of "full and by"-for when sailing thus obliquely to the breeze, the dog-vane does not show the true direction of the wind.*

When steering a course, much will depend upon the helmsman anticipating, or checking the ship in her inclination to yaw to starboard or to port; nor must he trust too much to the compass-card, but alternately watch the card, and the motion of the vessel's head passing the clouds, the sea, or any other objects which may present themselves to view, more fixed than the compass itself. In blowing weather, the feel of the helm and the force of the wind are nice criterions to judge whether the vessel be falling off or coming to. As the vessel *comes to* against the helm, it will appear *heavier*, and the wind drawing forward will seem stronger. On the contrary, as she *goes off*, and gives way to the power of the helm, it *eases* in the hand, while at the same time the wind lessens in its force as it draws more abaft. To an attentive and nice

observer, these circumstances, though seemingly trifling in themselves, indicate the motion of the vessel sooner than the compass. The stars or the breaking of the waves, at night, may also assist to prevent yawing the vessel about.

* The apparent direction of the wind, shown by the dog-vane, is a mean between the velocity of the ship and that of the wind, since that direction partakes more of the greater than of the less. If the ship runs east with the wind at south, having one-fourth the velocity of the wind, the vane will show about S. by E. $1/2$ E. The angle between the real and apparent direction of the wind may sometimes amount to two points or more.

413

The leech of the mainsail* is always best to steer by when blowing fresh; and when the wind is very light, the main royal. It frequently occurs with an old sea on, in light airs, that the sails all flap to the masts with every roll, and render it extremely difficult to tell when the ship is near the wind. If, under these circumstances, the officer of the deck will occasionally walk to the lee side, and cast his eye up on the fore part, or front of the light sails, he can more easily tell when the ship is near the wind, as the difference sometimes amounts to more than a point in the course which the ship might make.

Conning** is the art of directing the helmsman to steer the ship on her proper course by compass or by the wind; the person who performs this duty is generally the quartermaster or pilot. The following are some of the terms used in conning ship: When steering by compass or landmarks, and it is desirable that the vessel's bows should go to the left, or to port, the order is given, *Starboard!* Whereupon the helmsman turns the spokes of the wheel over to port, or in the same direction the ship's head is to go, and this according to the usual method of arranging the steering gear, has the effect of sending the tiller to starboard, and consequently of presenting the port side of the rudder to the action of the water.***

Hard a-starboard! means to heave the wheel over, so that the tiller will go to the extreme limit. When the vessel's head points in the right direction, the order is given, *Steady!* if slightly to the right of her course, needing to go very little to the left, the order is given, *Steady a-starboard*-that is, steady as she goes, but a little to starboard with the helm, if anything. In the same way to send the ship's head to starboard, order: *Port, Hard a-port, Steady a-port.* The terms wheel and helm are used indiscriminately.

Meet her! When the ship's head flies to starboard or port in obedience to the helm, then, as she approaches her course the wheel is hove, spoke by spoke, the opposite way, to check her gradually that her head may not pass the desired point.

Should the ship be standing along on a bowline, and the quartermaster perceive a cloth or two of the main-topsail to be lifting, he cries out, *No higher!* by which he means that the ship is not only too high, or too near the wind, but that she should go off a little. Whereupon the helmsman gives her a spoke or so, of the weather wheel. On the contrary,

* As the leech of the mainsail reaches farthest to windward, it will be the first to lift in coming to the wind.

** By a contrivance of telegraphic wires, the officer of the deck, standing on the forward bridge, can communicate his orders to the man at the wheel, and receive a response with the utmost certainty.

*** But see closing paragraph of Chap. XXI.

414

should the quartermaster observe that the vessel was not quite near enough, he would say, *Nothing of!* meaning to let her come to the wind, when the helmsman must ease the wheel and permit her to come up. When the ship is a good full and by, he says, *Very well thus!* Again, he orders, *Luff! Let her luff!* when the helmsman eases the wheel and lets her come up into the wind; if she does not come up enough the order is given, *Hard down!* To prevent her from going around on the other tack, the quartermaster exclaims, *No higher!* and to stand on again, *Keep her a good full and by!* or simply *Full and by!* meaning close by the wind with the sails *full*.

To keep the ship away, the order is, *Let her go off!* which may be followed by, *Hard up!* when off nearly enough, *Meet her!* and when heading the right way, *Steady so!* To haul her up to the wind again, *Let her come to! Bring her by the wind! Keep her full and by!* When any of these orders are given when sailing by the wind, or steering a course, you may see a bad helmsman heave his wheel over inconsiderately, giving the ship a rank sheer. This should be corrected by ordering him to give her a *small helm*. There are other expressions, such as, Nothing to starboard or port. "*Nothing to the N'd, &c., of your course.*" *Mind your weather wheel! Keep her a clean full! right the helm!* or put it amidships; *Shift the helm*, or change it from one side to the other, &c. When sailing with the wind aft, the terms starboard and port are used, and the same should be observed with the wind quartering to prevent mistakes.

As a general rule, in the service, when the helm is a-starboard, the turns of the starboard wheel rope will be found to have accumulated around the forward half of the barrel of the wheel-for a port helm the turns will, be found aft. A midship helm is indicated by the midship spoke of the wheel which is made differently from the rest that it may be detected at night by the touch.

In contriving any new steering gear it is quite an important item that the working of the wheel does not differ from that to which seamen are accustomed; that is, to *heave the wheel in the direction the ship's head is to go*- otherwise, at some critical juncture, confusion may ensue, and probably serious disaster.

The perfection of equipping a ship with spars, rigging and sails, consists in so disposing them that the efforts of the forward and after sails to turn the ship will be so exactly balanced as not to require any continued assistance from the helm in either direction. Of the two evils, however, seamen have more patience with a ship disposed to, approach the wind than with one needing the continued action of the helm to keep her from falling off.

When a vessel is headed off from her course, the yards are braced up sharp, sheets trimmed aft, and by keeping her as near as possible to the wind, with the sails all full or drawing, she is then "close-hauled;" and the tack she is on is designated by the side of the vessel on which the wind blows; for instance-if the yards are braced up by the port braces, having the wind forward of the starboard beam, she is then "*close-hauled on the starboard tack,*" or "*has her starboard tacks aboard.*"

Your port of destination, or the point for which you wish to steer, being in the direction from which the wind blows, the nearest you can steer to that course, is when the vessel is close-hauled. In this case she will, if a square-rigged vessel, lie within from five and a half to six points of the wind (some vessels working nearer to the wind than others). And if, after standing on one tack a certain length of time, you "*go about,*" and stand on the other, and so on, you are approaching the object continually, in the proportion of about one-third of the distance sailed. This is termed "*working,*" "*beating,*" or "*turning to windward.*"

Tacking is the most usual method of going from one tack to the other, in moderate weather and with a good working breeze. It has this advantage over all others, that you lose nothing to leeward when it is properly performed; for vessels will frequently, if well managed, luff up head to wind, and go about, without for a moment losing their headway, but, on the contrary, gain several times their length directly to windward, while in stays.

In working to windward, the wind frequently "*veers and hauls*" three or four points, heading the vessel off or allowing her to come up; this is particularly the case in the vicinity of land. The proper moment to tack in such cases, is when the wind is heading her off, for on the other tack you will evidently gain more to windward. By watching attentively, and taking advantage of such slants of wind, keeping the vessel a good full, and by the wind, you will gain much more on your course, than if you stood a certain number of miles or hours on each tack.

We will now proceed to "*tack ship*" under courses, topsails, topgallant sails, jib, and spanker; giving as nearly as possible the treatment for different vessels, and the necessary orders.

Ready about!

Keep her a good full for stays, see the men at their stations, viz.: a hand by the jib-sheet, hands by all the bowlines, lifts, tacks, and sheets; hands in the chains to overhaul the lee main sheet; the clew-garnets manned; topmen

at the breast back-stays, if any, and a few aloft to overhaul the lifts, and to attend to the out-riggers; a good helmsman at the wheel; a quarter-master at the conn; a few hands at the spanker sheet and lee topping-lift, and all the rest of the force at the weather main and lee cross-jack braces, lee main tack and weather main sheet. The men being at their stations, proceed as follows:

Ready! Ready! and to the man at the wheel, *Ease down the helm!* Fig. 477, No. 1.

Haul the spanker boom amidships. The helm being down, order

HELM'S A-LEE! Ease off the fore and jib-sheets.

Overhaul the weather lifts! She is now coming up rapidly to the wind, and as soon as the sails shake, the wind being out of the lee clew of the mainsail-

RISE TACKS AND SHEETS!

The fore and main tacks and sheets are let go and the clews of the sails hauled up by the clew-garnets, high enough to clear the hammock rails; at the same time, *Shorten in the main lee tack!* and weather sheet. Haul taut the lee spanker boom topping-lift, and overhaul the weather one;* and as soon as the wind is directly ahead, or a little on the weather bow

Haul taut! MAINSAIL HAUL! Fig. 477, No. 2.

The lee braces and the bowlines are let go, and the yards swung around briskly by the weather braces; hauling aboard the main tack, and hauling aft the sheet. To hasten the operation, the order is sometimes given, *Haul forward the lee main tack and main to' bo'line!* Brace the yards sharp up, trim them by the wind, and haul taut the weather braces and lifts; has now the sails on the foremast aback, which, with the jib, are paying her off rapidly.

Man the head braces!

Man also the fore tack, sheet and head bowlines; and as soon as the after sails take, or are full

Haul well taut! LET GO AND HAUL! To the man at the wheel, *Right the helm!* Brace around the head yards briskly; boarding the fore tack and hauling aft the sheet, as the yards are swung. And, as with the main, the order is frequently given, *Haul forward the fore tack and head bo'lines!* Brace up sharp, trim the yards. Fig. 477, No. 3.

Haul taut the lifts and weather braces! Steady out the bo'lines! The lower lifts and the braces are hauled taut, and the weather leeches of the sails hauled out by the bowlines. Keep her by the wind.

When you swing the after yards, the wind being ahead, shift over the jib sheet, when it will take the right way, and trim aft.

In vessels which are dull in stays and go off slowly after

* Not applicable to ships having but one topping-lift.

Plate II2

Fig.477

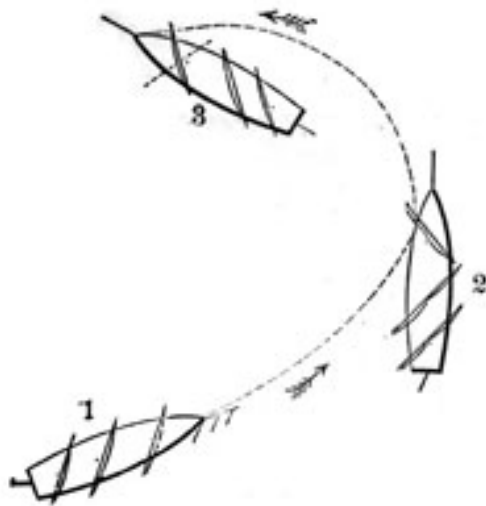


Fig.478

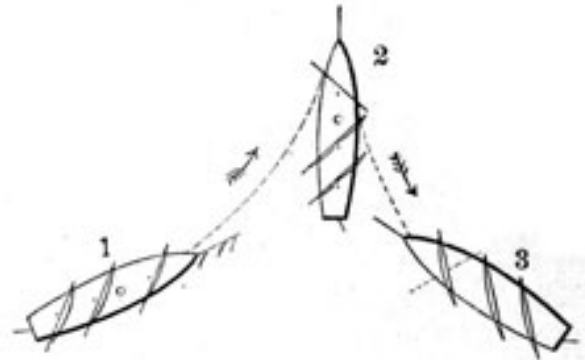


Fig.479

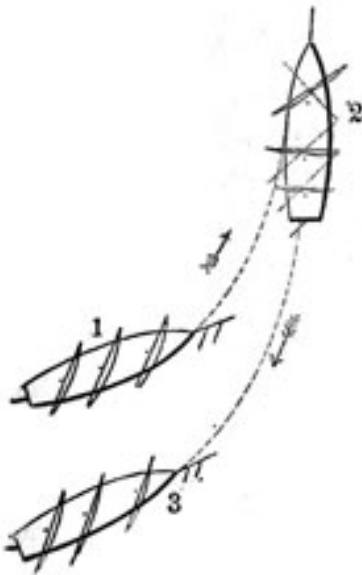


Fig.480

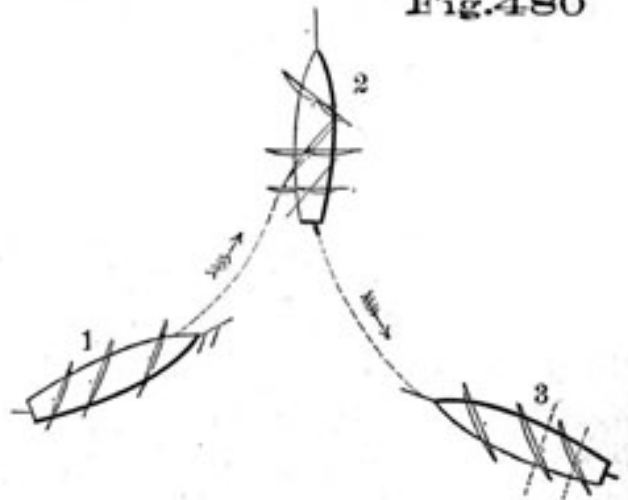
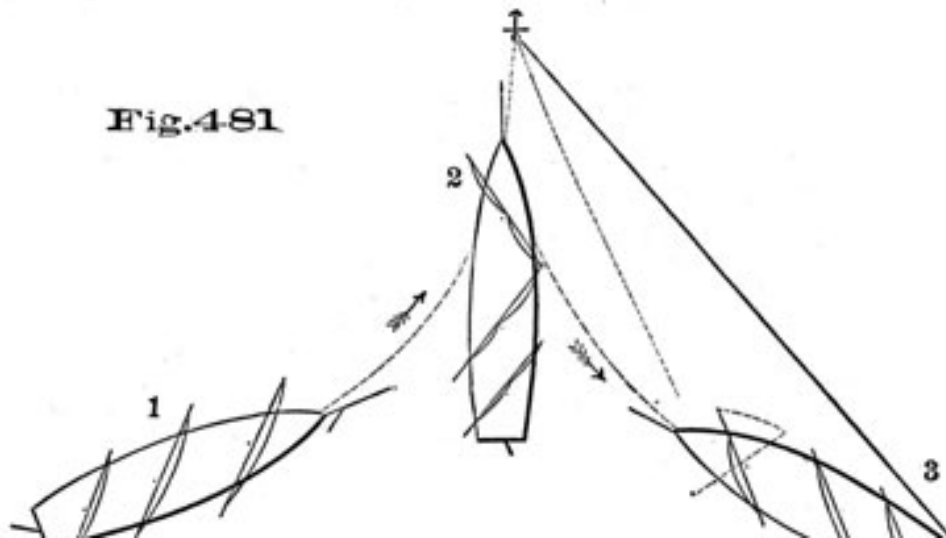


Fig.481





coming up head to wind, and particularly in a light breeze, it is advisable to keep the fore tack fast, to pay her off, when you rise the main tack; in which case the order will be, **RISE MAIN TACK AND SHEET!**

When the mainsail is not set, to haul the after yards, order-

MAIN-TOPSAIL HAUL!

In determining the moment to swing the after yards, you must be governed by the strength of the wind, and the qualities of the vessel. The general rule, and a safe one, is to do so when the wind is directly ahead. But with a good working breeze, and the vessel coming up briskly, it is best to haul them when the wind is about one point on the bow, before coming head to wind; for then the wind on the weather leeches of the sails forces them around smartly, and affords you time to brace up, trim the yards, and get the main tack down, before it becomes necessary to swing the head yards.

When the after yards take, and while bracing around the head yards, vessels frequently are falling off so rapidly, that before they can gather headway, they bring the wind abeam, and sometimes abaft the beam. In which case, as soon as the head yards take

Avast bracing! **FLOW THE HEAD SHEETS!** putting the helm a-lee, if she has headway.

As she comes up to the wind, **BRACE UP! GATHER AFT!** Brace up sharp, trim aft the head sheets, and meet her with the helm.

Some vessels, particularly those that carry a weather helm, requiring very little after sail when close-hauled with a stiff breeze, will not fall off after the after-yards take, and frequently will fly up into the wind while you are bracing around the head-yards; in which case, be careful not to brace round the head-yards, until she is well around; and if she flies up into the wind, let go the main sheet, and, if necessary, brail up the spanker, and haul in the lee cross-jack braces.

Should you haul the head-yards too soon, the ship may come to again, in which case, if the above method fails, *Rise fore tack, and sheet, clear away the head bo'lines!* **BRACE ABOX THE HEAD YARDS!** and box her off again.

When the helm is put a-lee for stays, it should be kept so until she loses entirely her headway; then,

If you perceive that the vessel comes up to the wind slowly, and you have any doubt of her staying, haul down the jib, haul the spanker boom well over to windward, overhaul well the foresheet, and as you rise tacks and sheets, check the lee fore-topsail brace, observing to brace it up again as soon as it is aback, and to hoist the jib or haul aft

27

418

the sheet, as soon as it will take the right way. This will, in most cases, insure the evolution, though it tends to deaden the "*head reach*," and should not be otherwise resorted to, except in working to windward in a narrow channel; when, having stood boldly on to either shore, particularly the weather one, you are fearful of head reaching too much in stays.

TO TRIM YARDS.

When close hauled. First, brace the lower yard up sharp, belay the lee brace, and haul taut the weather one; then trim the top-sail yard, if for a stiff breeze, with the weather yard arm about a half point abaft the lower yard, and the top-gallant trimmed by the topsail yard in the same way, and so on.*

In a light breeze with a smooth sea, when it is desirable to gain as much to windward as possible, the upper yards may be braced *over* the lower, and all got as nearly fore and aft as they will go, and always, except in very heavy weather, the sails should be taut up, and sheets close home or flat aft.

When the wind is abeam, if the yards be so, braced that the angles between them and the wind may be a point and three quarters *greater* than the angles formed by the yards and the line of the keel, that trim will produce the greatest headway.

The angle between the wind and yard should always be greater than between yard and keel, till the wind gets aft. when they are equal.

As the dog-vane is deceptive, the practical way to ascertain if the yards are laid well, is to luff the ship to by the compass a point, a point and a half, or two points, as the case may be, when if the yards are properly braced the sails will shake, thus giving the number of points free. The same may be ascertained by bracing to the mizzen topsail.

It is necessary that all sails should be trimmed to stand as flat as possible. The more a sail is made to approach to a flat surface, either by or before the wind, the better. (See SAILS.)

Fincham gives 19 ° as the angle the main yard should form with the keel, when close-hauled. This agrees with

* The upper yards should be braced in more than the lower, first, because the larger sail having greater curvature than the smaller must have its yard braced up to a sharper angle, that the plane of both may have

the same angle with the keel; second, because the upper portion of the sail being attached to the yard approaches nearer to a plane than the lower part which bellies out, hence the upper part need not be so sharp, and thirdly, the lighter yards and braces require a greater angle for their support. Further, the upper yards being in, when the main royal is just lifting all the other sails are a "clean full and by," which makes it a good sail to steer by.

419

the general practice; for many ships work within ten points.

We find theorists saying that the wind in passing from the sails on the foremast becomes more fore and aft, when it strikes the mainsail, and that therefore the after yards should be braced sharper than those forward. But in practice it is much better to keep the fore yard sharper, so that in "luffing to," a cloth or two of the main topsail will be lifting when the weather leach of the fore-topsail is just trembling. By this means a ship is more readily kept away again. Were the suggestions of theory adopted in this case the fore-topsail might catch aback, while shivering the main, and pay the ship off on the other tack.

Rules for bracing yards are at best but general guides to practice, and the ready skill of the seaman will have to be constantly relied on in the minor details of trimming yards and sheets, in order to get all the speed out of a ship. Probably the best school for this, as well as for many other points in practical seamanship, is in squadron sailing.

TO HAUL OF ALL.

The evolution of tacking may be performed in a smart working vessel, and a light breeze, by swinging all the yards together. The crew must be properly divided at all the braces, weather head and main, and lee crossjack. Then let her come up head to wind, and fall off on the other tack, shifting the helm if she gathers sternboard, until she brings the wind about five points on the other bow. Then give the order, *Haul well taut!* HAUL OF ALL! swinging around all the yards briskly. *Right the helm!* Board the fore and main tacks, and haul aft the sheets. Trim the yards and haul the bowlines. This is not a necessary operation, and only done to try the activity or force of a crew, and the qualities of the vessel.

MISSING STAYS.

A vessel in tacking may come to a stand before the after-yards are swung.

Assume the ship. to be on the port tack dead in the water after the order "rise tacks and sheets," to return to the same tack:

FLATTEN IN THE HEAD-SHEETS! by hauling them in amidships.

EASE OFF THE SPANKER SHEET! Should this be insufficient:

Port head braces! Clear away the head bowlines! BRACE ABOX THE HEAD YARDS! leaving the helm hard a-starboard for sternboard.

As she goes off with sternboard to starboard, DRAW JIB! and BRACE AROUND THE HEAD YARDS! As she comes to the wind again board the fore and main tacks, haul aft the sheets, steady out the bowlines, and as she gathers headway right the helm, and stand on till with enough way on. for another trial.

In Irons. But it is more common for a vessel to come up properly, and then, when the after yards have been swung, to lie dead in the water, or "in irons" as it is termed.

You must now do one of two things: either box the ship off to the old tack or wear around on the new.

Suppose the vessel to have been on the port tack, her helm is a-starboard; her after-yards braced around by the port braces; her head-yards sharp up by the starboard braces:

Leave the helm a-starboard for sternboard, haul up the mainsail, brail up the spanker, *Man the port head, starboard, main and port crossjack braces! Clear away the head bowlines! Haul taut! SQUARE AWAY THE AFTER-YARDS, BRACE ABOX THE HEAD YARDS!* Then,

1st. To bring her back to the old (port) tack. Fig. 479.

As she falls off to starboard, brace up the after-yards by the starboard braces. When they take, man the starboard head braces, and *let go and haul* as in tacking. Set the mainsail and spanker when she has fallen off enough, right the helm and stand on for another trial. Fig. 479, No. 3.

2d. To bring her around on the new tack (by box hauling), Fig. 483. As she falls off to starboard man the port after-braces and keep the after-sails lifting; when she gathers headway shift the helm (No. 3), squaring the head-yards to give her headway, and allow her to come to the wind. When the wind gets on the starboard quarter, the after-yards being sharp up on the starboard tack, set the spanker and haul aboard the main tack; as she comes to meet her with the helm and head yards. (No. 4.) Fig. 483.

From the above it will be noticed that when a ship in irons has squared her main yard and braced abox she will be either restored to the old tack or box-hauled to the new tack according to the after-braces manned. The helm in both cases remains the same as her head must go in the same direction. To go back to the former tack man the former lee braces (in this instance the starboard after-braces), to box-haul to the new tack man the former weather braces (in this case port after-braces).*

* If you could be quick enough in squaring the after yards and the ship did not tend to fall off from the wind when in irons, squaring the after yards briskly and shifting the helm for sternboard might force her around on the new track as in Fig. 480, without having to lose as much ground as in Fig. 483. But the tendency to fall off to leeward is generally too pronounced to allow of this manoeuvre in steamers under sail.

Fig.482

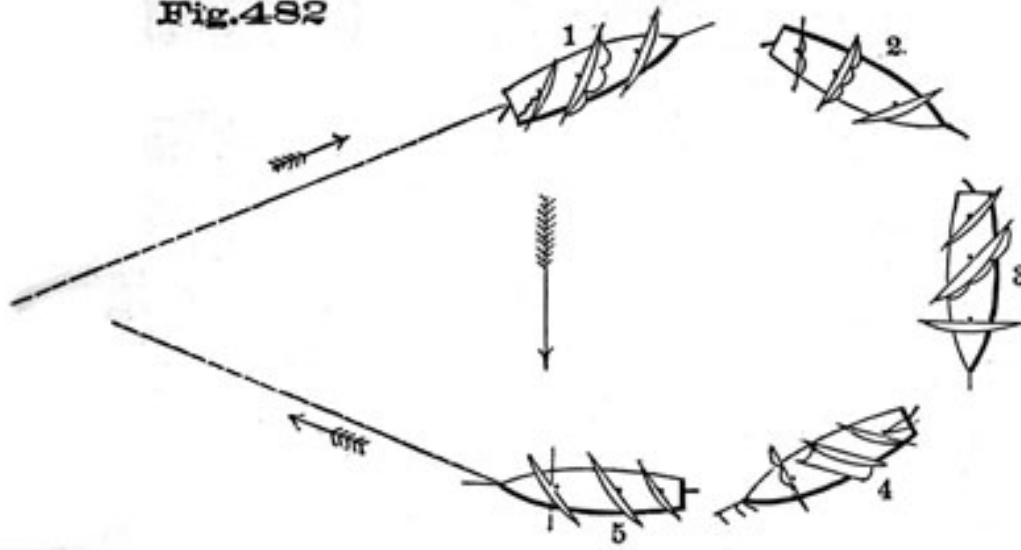


Fig.483

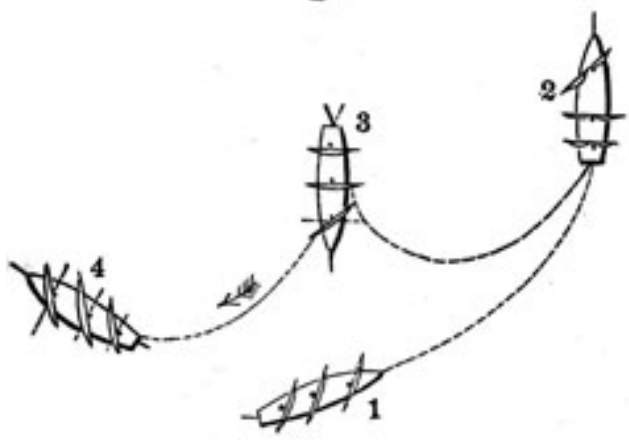


Fig.484

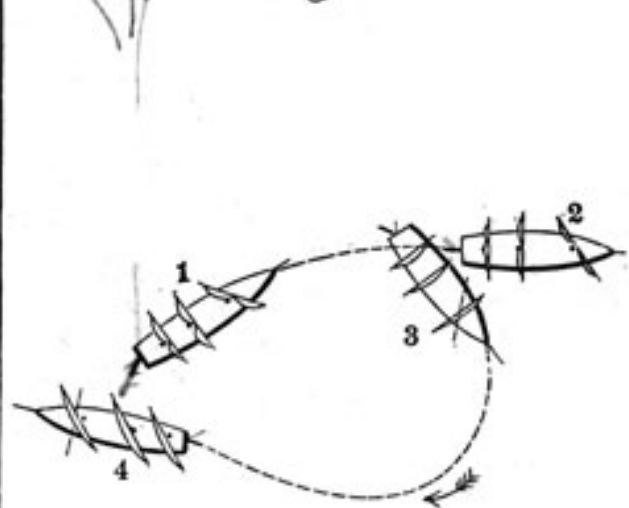
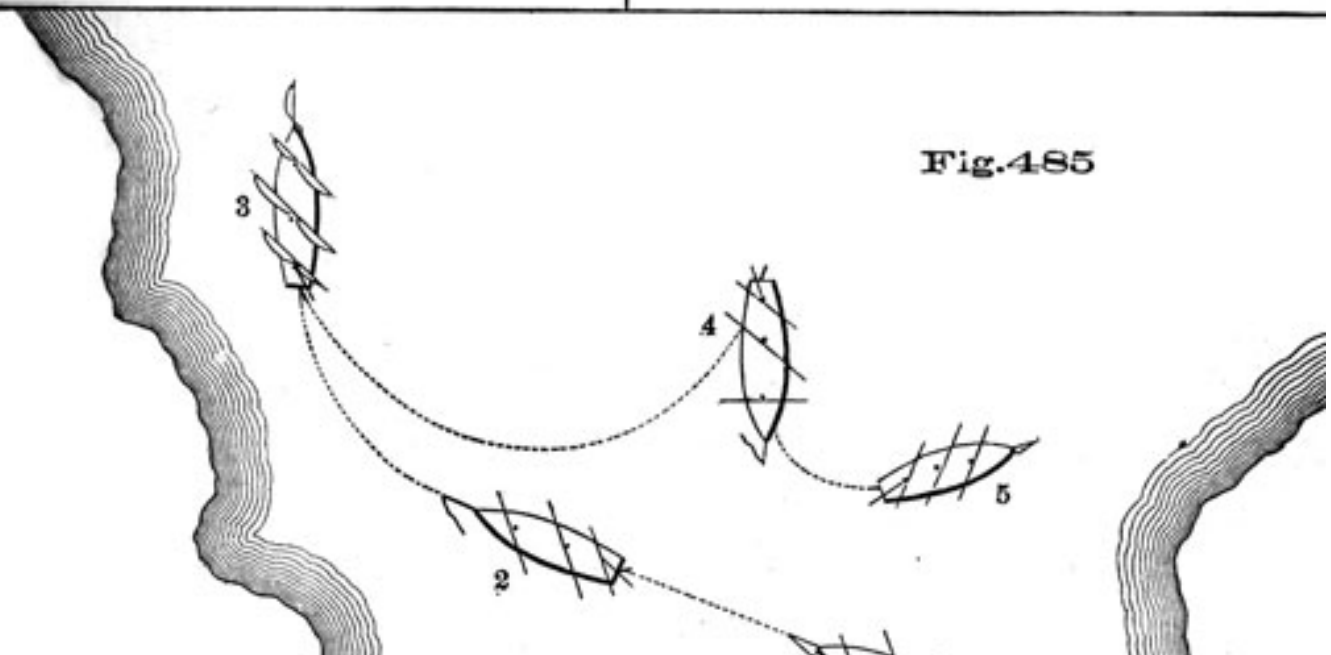


Fig.485



TO TACK SHIP UNDER DOUBLE-REEFED TOPSAILS.

Call all hands about ship, watch for a smooth time and ease down the helm; haul down the jib, and aft the spanker sheet as she comes to. HELM'S A-LEE! Ease off the fore sheet, keeping fast the tack to assist her around against the sea. When the wind is out of the mainsail, RISE MAIN TACK AND SHEET! *Let go and overhaul the weather lifts!* When the wind is nearly ahead, *Haul taut!* MAINSAIL HAUL! brace sharp up the after yards; get the main tack down and the sheet aft, hauling the bowlines; shift over the jib sheet and hoist away the jib as soon as it will take, and bear over the spanker boom. When she gets sternboard, shift the helm; RISE FORE TACK AND SHEET! and when the after sails fill, *Haul well taut!* LET GO AND HAUL! Haul forward the fore tack and head-bowlines. Should she fall off rapidly, *Avast bracing!* As she comes to, meet her with the helm. BRACE UP! GATHER AFT! Trim the yards; haul well taut the weather-braces and lifts, and steady out the bowlines, clear up the decks and pipe down.

The head yards should not be braced in, that the ship's headway may be preserved, that method answering only for a light breeze and smooth sea.

TO TACK SHIP, USING A DRAG.

When near the land in a light breeze. Secure a single block of suitable size to the jib-boom end and reeve a small towline through it, bringing one end aft to the weather quarter, outside of everything, and bend it to the drag, which may be triced up to the weather main brace bumpkin. Have a hundred fathoms or so of the line ready for running out, and when all is prepared, *Ease down the helm! Let go the drag!* Luff around as in tacking, and having the towline well manned, when nearly head to wind, *Haul taut!* MAINSAIL HAUL! WALK AWAY WITH THE SPRING! The drag being now well on the weather quarter, the spring will easily carry the ship's head past the direction of the wind. When the after sails fill, LET GO AND HAUL! Walk the drag up to the jib-boom end, get it in board and ready for use again.

For experiments on board the practice ships, halliard-racks, lined with canvas, have been found to answer. On a lee shore, in very deep water, a sea-anchor might be used in the same way, which would be less expensive than *club-hauling*, by letting go a bower. Or an old boat, with a hole stove in its bottom, might answer, in which case the hawser would have to be cut as soon as the ship got around.

CLAWING OFF A LEE SHORE.

In clawing off a lee shore, all the sail possible must be carried. If blowing hard in squalls, the ship must be *luffed through* them. If blowing *very* hard, the topsails should be furled, and whole or reefed courses kept on her as long as possible, as she will hold a better wind.

CLUB-HAULING.

Fig. 481, Plate 112. In working off a lee shore, against a fresh breeze and head sea, when you cannot risk missing stays, and have not room to wear, you must then resort to this evolution.

Get the lee anchor off the bows, and ready for letting go; the cable ranged, bitted, and well stoppered; bend a hawser to the ring of the anchor, lead it in at the lee quarter, and secure it well; have hands stationed at the anchor ready for letting go; a carpenter, with an axe, ready to cut away the hawser, and the armorer ready to unshackle the chain.

Station the men for stays, and proceed as in tacking, until she will come up to the wind no further; and the moment she loses her headway, let go the anchor, and brace around the after yards. As the anchor fetches her up, she will swing head to wind, bringing the head sails aback. *Man the head braces! Veer away the chain!* the hawser from the lee quarter springing her around to the wind on the new tack. As soon as the after sails take, *Cut away the hawser!* LET GO AND HAUL! swinging around the head yards. Fig. 481 (3). Bring her by the wind and right the helm; trim the yards and haul the bowlines.

You have expended, by this evolution, an anchor, part of a cable, and hawser; but if resorted to with judgment, in an extreme case, you may have saved your vessel.

The advantage of letting go the lee anchor, in preference to the weather one, is, that when it fetches her up, it will bring the wind a little on the bow from which the cable leads, and in casting, as you unshackle, the cable will run out clear of the stem.

A ship may perhaps be placed in the same situation as to the land, with the wind moderate, and the swell sufficient to make it doubtful whether she will tack or not; in such a situation a kedge might be sufficient to insure the tacking of the ship.

Club-hauling Steamers. Club-hauling, on many occasions, might be made most useful to steamers, when required to turn in a narrow channel, or in blowing weather on a lee shore, where, owing to their great length,

they cannot otherwise be brought round. In such a case, when the steamer comes head to wind, her anchor might be saved, with care and attention, as she would then have her full propelling power in the right direction, namely, head to wind and right off from danger.

To Work to Windward with another Ship in Tow. The towing hawser is secured to the bitts or mainmast and lashed amidships on the taffrail, having plenty of parcelling in the wake of all chafes. When ready for stays, direct the tow to put her helm up and veer under your lee; at the same time put your helm down, which being assisted by the towline of the lee quarter, will bring the ship's head to the wind; as soon as you have gathered headway on the other tack, the towrope will, in time, bring the tow around; if her masts are standing, let her swing the yards at the proper time, and she will be directly in your wake.

WEARING.

Fig. 482, Plate 113. Wearing or veering is another method of going about from one tack to the other. This is only resorted to in a good working ship in heavy weather, with a sea on the weather bow; or under easy sail, in light airs; when, in either case, the vessel has not sufficient headway for tacking. It is exactly the reverse of tacking, for you run the vessel off from her course, or the wind, until she comes around again on the other tack, having performed a sweep of some twenty points; in doing which, she must lose considerably to leeward; therefore the loss should be made as little as possible.

To Wear Ship in a Light Breeze, under courses, topsails, topgallant sails, jib, and spanker, give the order-

Stations for wearing ship!

Station the men as in tacking.

Main clew-garnets and buntlines! Spanker brails! Weather main and lee crossjack braces!

The men being at their stations as directed, order, *Haul taut!* UP MAINSAIL AND SPANKER! *Put the helm up! Clear away the bo'lines!* and as she falls off, BRACE IN THE AFTER YARDS! Keep the mizzen-topsail lifting, and the main-topsail full, the former to present no opposition to her falling off briskly, and the latter to keep up her headway, without which wearing is, in a very light breeze, a tedious operation-*Overhaul the weather lifts!* Fig. 482 (2).

She falls off, bringing the wind abaft the beam, and you have braced in the main yard until it is square; continue bracing the crossjack yard to keep the sail lifting, until it is braced up sharp on the other tack.

She continues falling off, and you have now the wind directly aft. *Man the weather head braces!* RISE FORE TACK AND SHEET! *Clear away the head bo'lines!* LAY THE HEAD YARDS SQUARE! *Shift over the head sheets!* Fig. 482 (3).

She has now the wind on the other quarter. Haul out the spanker, and brace up sharp the after yards. *Man the main tack and sheet!* and when manned, *Clear away the rigging,* HAUL ABOARD! Fig. 482 (4).

The after yards being braced sharp up, with the mainsail and spanker, bring her to the wind. The head yards being square, and the jib-sheet flowing, present no opposition to her coming to. As she comes up, brace up the head yards, Fig. 482 (5), keeping the sails full, board the fore tack, haul aft the sheet, and meet her, as she comes to, with the jib and helm. When by the wind, right the helm, trim the yards, *Haul taut the lifts and weather braces!* *Steady out the bowlines!*

To Wear Ship in a Fresh Breeze. The only difference in the evolution is, that you may, with a good breeze, having headway on that keeps her under the complete management of the helm, keep the main-topsail, as well as the mizzen, lifting as she goes off, which hastens the movement; and *bracing the after yards sharp up on the other tack, before you touch the head yards.* When before the wind, brace the head yards square, and brace them up as she comes to. As soon as the wind gets on the new weather quarter, haul out the spanker and board the main tack smartly, or the watch will be tardy in reaching the head braces to brace up, and will have a heavier haul in consequence.

TO WEAR IN A GALE

UNDER A CLOSE-REEFED MAIN TOPSAIL, FORE, MAIN, AND MIZZEN STORM STAYSAILS.

Stations for wearing ship! Clap a stout lashing around the bunt of the foresail and yard, and have a hand in the slings in readiness to overhaul the rigging. Hook the weather storm staysail sheets, stretch along the fore tack-*Man the main and mizzen staysail downhauls!* and have hands by the halliards and sheets. *Man the weather main, and lee crossjack braces!*

In a gale, with a heavy sea, vessels lying to will come up and fall off four or five points. Watch for a smooth time, and when she is falling, off put the helm up-HAUL DOWN THE MIZZEN STAYSAIL! bracing in the after yards as she falls off, keeping the main-topsail full, and the crossjack yard pointed to the wind. Attend the lifts, as in wearing

under all sail. As the wind draws aft, ease off the main staysail sheet; and when of no further use in forcing her around, haul it down, shift over the sail, and gather aft the sheet.

If the vessel in this situation will go off no further, as is sometimes the case, man the weather fore tack, overhaul the gear, ease down the clew-garnet, and haul aboard the weather clew of the foresail; which will increase her headway, and with her helm still a-weather, will serve to pay her off. A foresail in this state is "*goose-winged*."

When before the wind, haul up the foresail, *Right the helm!* and square the yards fore and aft. Take in the slack of the fore staysail sheet. *Man the main and mizzen staysail halliards and the main braces!*

Watch for a smooth time, then ease down the helm, bracing up the after yards; **HOIST THE MAIN AND MIZZEN STAYSAILS!** and brace up the head yards as she comes to; haul taut the lifts, weather braces, and main top-bowline.

As soon as the staysails are hauled down, shift them over to the other side of the deck, and take in the slack of the sheets to be in readiness for hoisting.

To Wear under Bare Poles. Man the weather fore rigging, or place tarpaulins outside the weather fore shrouds, put the helm a-weather and work the yards as usual. Should there be any doubt of the ship wearing under the circumstances, take the precaution to send down the yards on the mizzen, also the mizzen topmast and topgallant masts; get a span on the mizzen mast, bend a hawser to it and securely belay the end inboard. Now, if she does not pay off, cut away the mizzen mast as a last resort, veer away the hawser and use it as a drag.

BOX-HAULING.

Fig. 483, Plate 113. This evolution may be performed in working out of a narrow passage; when, having approached the weather shore so near as to have no room for head-reaching, you are not willing to lose ground by the ordinary method of wearing.

Ready about! Station the men as for stays. *Man the main clew-garnets and buntlines, and spanker brails!* *Put the helm down!* *Light up the head sheets and check the lee head braces!* to deaden her headway. As the sails lift, **RISE TACKS AND SHEETS! UP MAINSAIL AND SPANKER!** Man the weather head, and main and lee crossjack braces.

She comes head to wind, and as soon as she loses her headway, *Clear away all the bo'lines! Haul taut!* **SQUARE AWAY THE AFTER YARDS! BRACE ABOX THE HEAD YARDS! HAUL FLAT AFT THE HEAD SHEETS!** Fig. 483 (2). The helm is right for sternboard, she is going rapidly astern, and at

the same time falling off, forming with her keel the segment of a circle, or "*wearing short round on her heel.*"

As the after sails lift, brace them in to keep them lifting, until they are braced up sharp on the other tack; and brace square the head yards. As soon as the sails on the foremast give her headway, *Shift the helm!* Fig. 483 (3). The spanker boom having been shifted over on the other quarter, *Spanker outhaul! Main tack and sheet!* When the wind is aft, shift over the head sheets, and as soon as the spanker will take, *Clear away the brails!* HAUL OUT! *Clear away the rigging!* HAUL ABOARD! Board the main tack and haul aft the sheet.

The after yards, being braced sharp up with the spanker, head yards square, jib sheet flowing, and helm alee, she will come to the wind rapidly. Brace up the head yards as she comes to, and meet her with the helm and jib; trim the yards and haul the bowlines.

If to gain to windward in this evolution, use the helm and head sheets as in tacking; but if to avoid danger, jamb the helm hard down at once, flow the head and fore sheets and then proceed to back her around.

TO WEAR SHORT ROUND. (Fig. 484.)

Some officers make a distinction between box-hauling and wearing short round, as follows:

In any sudden emergency, haul up the mainsail and spanker, man the braces as above, and, without going into the preliminary of luffing up into the wind, as in box-hauling, put the helm hard up, square the after yards, and brace abox the head yards. Fig. 484 (1). The moment she loses her headway, shift the helm for sternboard (2). After which, proceed as in box-hauling (3) and (4).

There is a decided difference in the commencement of the evolutions. Either of them may be termed box-hauling -a term derived from the circumstance of bracing the head yards abox-and both have the effect of wearing the vessel short round. By the former, you lose less ground than by the latter, for a vessel, with good headway on, will range ahead some distance after the sails are all thrown flat aback.

HALF-BOARDS.

Beating up a river with a strong windward tide, fore-and-aft vessels may be luffed up into the wind with everything shaking, and then, as they begin to lose their way, permitted to fall off on the same tack, the tide in the meantime sweeping them up the stream very considerably. They may be thus enabled to weather a point of land, a vessel at

anchor, or other obstacle, when otherwise they would have been compelled to make a board or two to clear it.

In a tideway the half-board is of great use, but it may also be practised by ships at sea, sometimes, with great advantage, Thus, **READY ABOUT! Stations for stays! Put the helm down! Flow the head sheets!** The ship now flies to (for it can only be practised in a good working breeze), with everything shaking; when she has shot up into the wind a good distance, and commences to lose her way-*No higher! Flatten in forward!* and let her go off to a good full and by again.

When a ship is box-hauled, she may be said to make two half-boards; first, when she is *luffed up* into the wind, and again, when she is *backed up* into the wind stern foremost, by which she rather gains to windward.

To Back a Ship Around off a Lee Shore, Fig. 485, Plate 113. This evolution can be practised to very great advantage in moderate weather, and is particularly applicable when, beating in a river or channel, the ship misses stays and you have no room to wear. It may be remarked here, that this, as well as all other evolutions requiring the ship to be *backed astern*, should be adopted in moderate weather only, as there is danger, in a very fresh breeze and a rough sea, of injuring the pintles and gudgeons of the rudder, and straining the rudder-head. Having stood well over on one shore (position No. 2, Fig. 485), *Ready about!* Luff to, rise tacks and sheets, and when you judge proper, **MAINSAIL HAUL!** If she continues to go around, proceed as in tacking of course; but should she come to a stand-still, and refuse stays, **BRAIL UP THE SPANKER! Man the head braces!** and **LET GO AND HAUL!** as usual. You have now the wind about a point on the weather bow, everything hard aback and the helm a-lee (No. 3). With this arrangement of canvas she will soon gather sternboard and pay off rapidly at the same time, bringing the wind abeam, with everything aback, thus *sailing astern*. But the helm and the head sails cause her stern to luff into the wind, and the after leeches of the topsails will soon commence lifting.* The wind now gets aft, and the sternway, which has been decreasing, will cease, when the helm must be shifted. She now commences to forge ahead, the after leeches of the mainsail, main and mizzen topsails being full. As soon as it will take the right way, haul out the spanker and bring the ship by the wind on the new tack.

With a slow-working ship, or in a light breeze, you cannot back around stern to wind so easily, but, bringing the

* The sails, being hard aback, have the effect of heeling the ship and burying the lee quarter, thus causing her stern to luff more rapidly to the wind, than if the after yards were square, as in box-hauling.

wind on the quarter, a vessel will stand so and commence coming to the wrong way. This the judgment of the officer will anticipate and prevent by laying the head yards square (No. 4), which will give her headway; and the helm being shifted, will bring her around, assisted by the after leeches of the after sails and spanker, when it will take (No. 5). In light weather the mainsail may be left down. This is good exercise for the class in charge of the deck during the practice cruise.*

REMARKS ON TACKING.

This evolution, though the most common in the whole practice of seamanship, nevertheless involves points of the nicest judgment and skill to effect its proper performance. In the first place, care must be taken that the ship be by the wind, not rap full; nor jammed up to such a pitch as to have no headway at all; but simply, so that all the sails may draw without trembling, and when the least touch of lee helm will cause them to shake. Again, do not put the helm down suddenly, but *gradually*, spoke by spoke, which gives the vessel all her velocity in coming to the wind, increasing her distance to windward, and keeping her under command after the after yards are swung. If, on the contrary, the vessel be suddenly brought to the wind by the helm being put down *all* at once, the ship will most certainly lose her way, and consequently have sternboard before the head yards are touched. This often leads to missing stays. And here arises another point, viz., the order, "helm's a-lee," should *not* be given until the *jib lifts*, for so long as the sail is full, it is manifestly of service to the ship in staying; and when it shakes it is of no use, and then the sheet may be let go. If, on the contrary, the sheet be eased off beforehand, the sail begins immediately to "flap," and so it will continue until it fills on the other tack, or has altogether prevented the vessel from coming head to wind. The same may be said of the *fore-sheet*; and hence it is that officers often run the lee clew of the fore-sail well up at the order, "Rise main tack and sheet," which should be given when the *lee* leech of the mainsail lifts. The fore tack, however, should not be eased until after "mainsail haul," for otherwise the entire strain and pressure of the foresail (and that *aback* to), is thus brought upon the bowline.

With the spanker, the sheet must be hauled aft gradually, as the luff of the sail lifts, until the boom is amidships.

* When beating through the narrow entrance of Narraganset bay, on the night of. the 25th of September, 1863, in a fresh whole topsail breeze, the U. S. practice ship Macedonian missed stays twice, and was saved from going on the rocks by the performance of this evolution.

It is a common error to haul the sheet flat aft at once, thus making a back sail of it.

If the mainsail be hauled before the wind comes ahead, the main yard will fly around of itself; but if it be *not* hauled until the wind comes ahead, or on the other bow, it will occasion a very heavy and tedious haul. Instead, therefore, of watching the lifting of the spanker or the movements of the dog-vane, observe, rather, when the *weather leech* of the *main topsail* is well *aback*, as the indication when to haul the after yards; and *right* the helm when the wind fills the leech on the other tack. The head yards are then hauled as soon after as possible, observing, first, however, to brace and trim all sharp up aft.

In doubtful cases the windward flap of the spanker will admonish you to haul the main yard; and the pennant at the main will more truly indicate the direction of the wind than the vanes.

In tacking under *double-reefed topsails*, the practice of bracing to the head yards, *while the ship has headway*, should never be resorted to, as tending to destroy not only the effect of the rudder, which is of most consequence, but to check the velocity altogether. Under these circumstances, as soon as the vessel comes up head to sea, and loses her way, put the helm *amidships*, and as she gathers sternboard shift it *gradually*.

In their zeal to shift over the head sheets, fore-castle-men sometimes make a back-sail of the jibs, causing the ship to refuse stays.

When about to make a good haul of the yards, a few hands should run away with the slack of the brace, the greater number standing by to clap on as soon as the slack is through.

Should a lee top-gallant or royal brace jamb in stays, start the sheets at once.

When there is much sea on the bow, or when there is a swell with little wind, the ship will require coaxing. Take opportunities when she is inclining to come to, to haul the head sails down; ease the helm down, haul over the boom, and check the head bowlines and lee head braces. The main yard should not be hauled, nor head sails reset, nor fore tack started until the wind is decidedly on what was the lee bow. The later the haul of the main yard, the heavier will be the work; and as allowing it to bring up square for even a short time would probably cause the ship to miss stays, care should be taken to insure a good haul.

Should a squall strike the ship in stays, up mainsail and spanker, in royals and top-gallant sails, and slack the weather-head braces. If the squall is very heavy, get the vessel before the wind, and clew down; otherwise let go and haul.

REMARKS ON WEARING.

In ordinary cases, let the weather braces be started in *before* putting the helm up, and keep the main topsail leeches *lifting*;* this will bring the ship around (provided she had good headway at the offset) in a very short space. Observe, however, to put the helm up *gradually*, and to a brace the after yards entirely round, by the time the ship gets before the wind, letting go the *lee* head braces when the wind gets well abaft, as the forward yards will thus fly nearly square, and save some little pulling and hauling. When the wind draws on the other beam, meet her with the helm, jib, and lee head braces as she comes to.

If a vessel will wear readily, in place of taking in, or lowering a fore-and-aft mainsail altogether, it is better to drop the peak only.

In regard to keeping full the main topsail, while wearing, much depends upon the situation of the mainmast, which, owing to the position of the engine, may step unusually far aft, and the main topsail, by that means, become a luffing sail.

As boats may be made to steer by trimming, so a ship can be made to pay off by bringing the crew aft.

SAILING IN LINE.

When performing any evolution in the line, if sail will insure it, do not hesitate to make a sufficiency, even if it should be taken in immediately afterwards. Missing stays, or taking up much time and space in wearing, throws other ships into danger and disorder.

You may have been carrying enough sail to keep your station, but it does not follow that you have enough to carry you round when the signal for an evolution is made. If your leader is dull, but doing his best and in his station, of course you must not encroach on him; but you must be handy with your canvas, and sharp in freshening your way with it, just before your own turn comes to go about.

When about to leave the main yard square in stays, make a late haul, else the brace will go.

The rule for going about in succession in close order in the line is, to put the helm down when your next ahead is four points on the weather bow; in open order, five points.

In wearing, shiver your after-yards, when your leader is dead to leeward.

As ships when sailing in line are not at liberty to disturb

* An exception to this occurs in very light weather, when it is essential that the vessel should have headway to help her go off.

the order of sailing, it should be borne in mind that those emergencies requiring a vessel to be hove to, veered or luffed around on the other tack, must be provided for in some other manner.

This applies to steaming as well as sailing.

TO TAKE A SHIP IN TOW, BEING UNDER SAIL.

Having notified the ship of your intention, she will run a little free under easy sail; run along the weather side of the vessel, and when abreast of her, throw overboard a buoy with a light line attached. The ship to be towed grapples the buoy and hauls a hawser aboard.

The vessel to be towed may send her boats with a light line, to haul in the hawser.



[Previous Part](#)



[Seamanship
Home Page](#)



[Next Part](#)

Copyright (C) 2006 [Historic Naval Ships Association](#)

All Rights Reserved

[Legal Notices and Privacy Policy](#)

Version 1.00, 24 Apr 06

WIND BAFFLING

**COMING TO AGAINST THE HELM-TAKEN ABACK-CHAPPELLING-TRIMMING YARDS
AND REGULATING SAILS FOR CHANGES OF WIND-A CALM-COUNTER-BRACING THE
YARDS, ETC.**

COMING TO AGAINST THE HELM.

A VESSEL should always carry her helm as nearly as possible amidships, as she is then more completely under its guidance. A vessel that carries a strong weather helm, when by the wind, is liable, by the carelessness of the helmsman, to fly up, and in some cases, too far to be recovered without bracing the yards. Suppose, for instance, you are under all sail, by the wind, on the starboard tack-she comes to against the helm, proceed to recover her on the same tack.

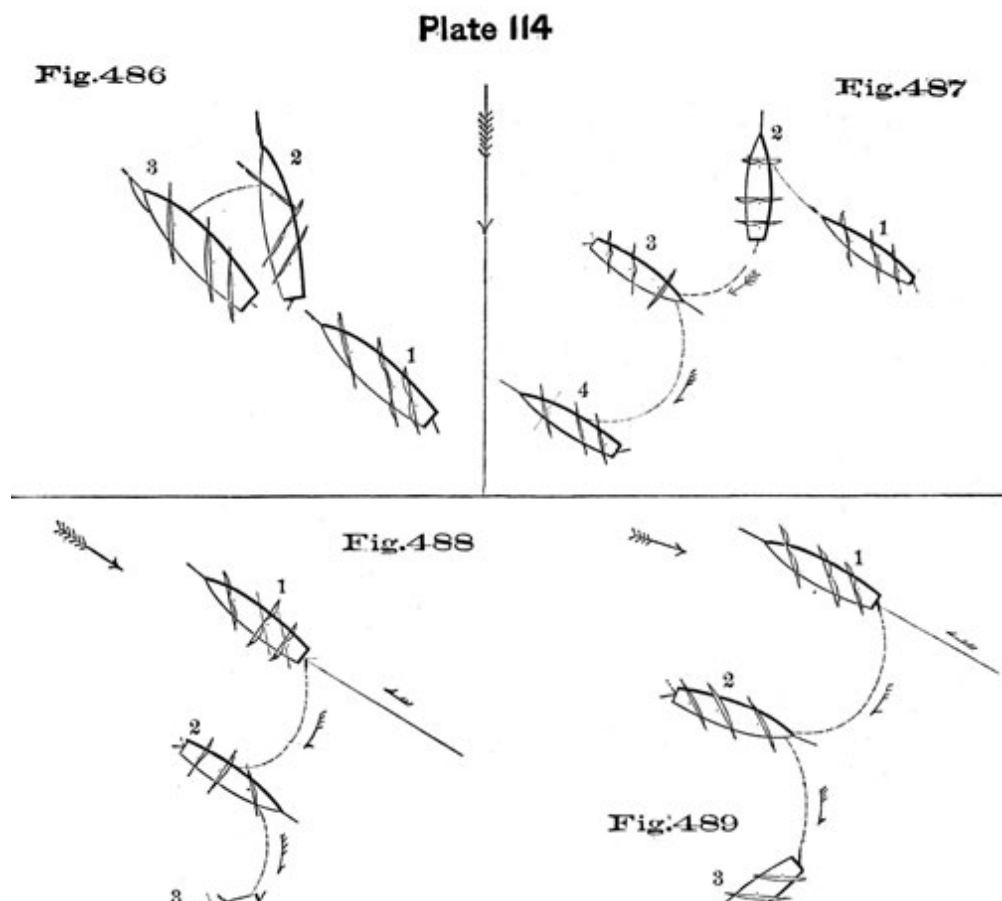
TO BOX OFF. (Fig. 486.)

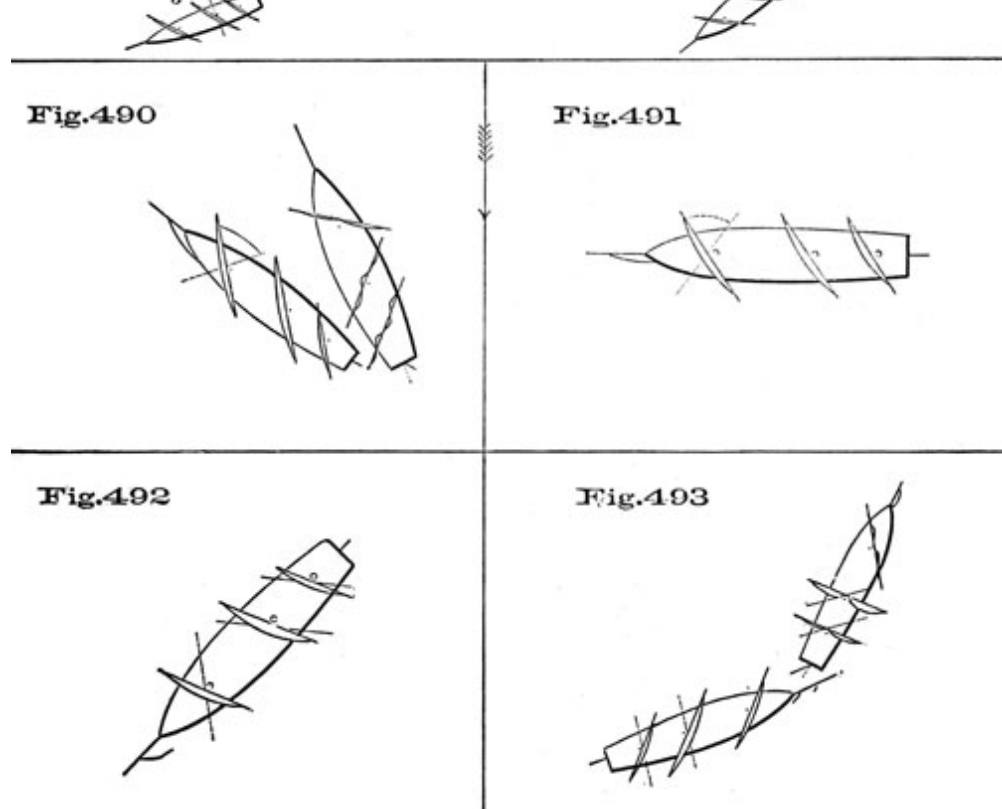
The moment you find her coming to, *Put the helm up! Flatten in the head sheets! Ease off the main and spanker sheet!* In most cases this is sufficient if the vessel has headway on, and she will fall off; then you may right the helm and. *Draw the head sheets!*

But if she still comes to against the helm, *Main clew-garnets and buntlines! Spanker brails! UP MAINSAIL AND SPANKER! Man the weather head braces! RISE FORE TACK AND SHEET! Clear away the head bowlines! BRACE ABOX THE HEAD YARDS!* If the wind is not already on the port bow this will effect your object, by boxing her off; and when the after sails fill, let go and haul as in tacking.

TO RECOVER ON THE SAME TACK BY WEARING.

If the head yards were not braced abox in time, and the wind is now on the port bow, clear away all the bowlines, and square the yards fore and aft. Fig. 487. She will soon gather sternboard and fall off to starboard, from the effect of the helm, which is right for sternboard. As the sails fill, brace in the after yards by the port braces to keep them shaking, keeping the head yards square; as she gathers





headway, shift the helm, and proceed as in box-hauling, which will have the desired effect. Fig. 487 (4).

TO CHAPEL SHIP.

To Chapel Ship (by the Wind on Starboard Tack). But if, instead of coming to, you are taken aback with a light breeze, to recover her on the same tack, proceed as follows: Put the helm to port, if she has headway on, haul up the mainsail and spanker, and square the after yards; the moment she gets sternboard, shift the helm (putting it to starboard), and she will fall off briskly to starboard. When the after sails fill and she gathers headway, put the helm again to port, and when the wind is astern, brace up the after yards by the port braces when the spanker will take, haul it out, and bring her by the wind. This is termed, "*chapelling*" a ship, by recovering her on the same tack without bracing the head yards. Fig. 488.

Sailing in squadron, if your ship does not go off by putting up the helm and flattening in the head sheets, proceed at once to tack, and carry sail and tack again when she has gained sufficient headway to return to your station. By this you will gain your station sooner than by the method given in the preceding paragraph, besides avoiding the probability of compelling other vessels, astern or to leeward of you, to leave their stations.

Both in chapelling ship and in "recovering on the same tack by wearing," we start with all the sails aback and the wind on the lee bow. It amounts to the same thing whether she came to against the helm or was taken aback by a shift of wind.

In both cases we lay the after yards square; in chapelling, the head yards are left untouched; in wearing, the head yards are laid square.

Recovery by wearing is, then, preferable to chapelling, for the head yards, when square, will fill and give headway sooner than if left braced up, and will also allow the ship to come to more rapidly when she is brought to the wind in completing the manoeuvre.

To Chapel Ship without Touching Brace. Fig. 489. This may be accomplished in light weather without touching a rope, excepting, may be, the spanker brails. A light breeze takes you flat aback; order the helm down (with reference to the way the yards are braced), and as soon as she loses way, *Hard up!* and brail up the spanker. The ship will now gather sternboard, and back around with her stern to the wind. (See "To back a Ship around off a Lee Shore," last chapter.) She will soon bring the wind right aft and come to a

the helm. She will now gradually gather way, when the after leeches of the sails, assisted by the helm and spanker, when it will take, will bring her to on the old tack. This is not an uncommon practice during mid-watches in the doldrums.

TAKEN ABACK TO GO ON THE OTHER TACK.

The vessel, being on the starboard tack, is taken aback, or has come to against the helm and brought the wind on the port bow. When not sailing in squadron, and no other circumstance renders it necessary to recover on the same tack, go around on the port tack, thus:

If she has headway, put the helm a-port, brace around the after yards, and proceed as in tacking.

If she has no headway, put the helm a-starboard for sternboard, up mainsail and spanker, square the after yards. As she pays off to starboard, brace up the after yards by the starboard braces, and when they fill, "Let go and haul," as in tacking. Set the mainsail and spanker, trim yards, haul taut the lifts, and steady out the bowlines.

BRACING IN.

The Wind Draws Aft. You have directions, as officer of the deck, to make the best of your way on a certain course, which is directly to windward. You are close-hauled, under topgallant sails, on the port tack. The ship comes up gradually to her course, and the wind continues to haul until it is directly aft.

Keep her full and by, and she will come up as the wind hauls until she is on her course. Then give directions to the helmsman, "*Steady so!*"

Finding that the wind draws aft, give the order, *Man the weather main and lee crossjack braces! Clear away the bowlines!* Brace in a little the main topsail, mizzen topsail and upper yards, and then brace in the fore topsail and upper yards, and ease off a little of the fore main, spanker, and jib sheets. *Aloft to loose the royals! Clear away the flying jib! Get the topgallant studding-sails ready for setting!* When ready, LET FALL! SHEET HOME! RIG OUT AND HOIST AWAY! If you carry staysails, you may also set them at this time; also the topmast stun'sail when it will draw.

After trimming the after yards, it is customary to order the officer of the forecastle to *Trim the head yards by the main!*

The Wind, still Drawing Aft, is now

Abeam. Brace in the after yards as much as the wind will allow, keeping the sails full. Then brace in the head yards, taking in the slack of the topgallant studding-sail tacks. Ease off the fore, main, spanker, and head sheets, and set the topmast studding-sail, if not already set.

A vessel is "*going large*" when the direction of the wind makes a greater angle than six points ($67^{\circ} 30'$) with the course; and when the wind is abeam or a little abaft, forming more than a right angle with the course, then all the sails feel the full force of the wind, and the velocity of the vessel ought to have gained its maximum.

The Wind is now on the Quarter. Brace the after yards in nearly square, and then the head yards, taking in the slack of the studding-sail tacks. *Man the weather main clew-garnet and spanker brails!* Haul up the weather clew of the mainsail, brail up the spanker, and set the lower studding-sail.

The Wind still Draws Aft. Square the after yards and then the forward ones; get the lower lifts down to

the square mark, and haul down the jib and flying-jib. Man the lee main clew-garnet, buntlines and leechlines, and haul the mainsail up snug. Haul down the staysails.*

The Wind is now Directly Aft. *Stand by to set all the starboard studding-sails!* When ready, hoist the topmast studding-sail up to the lower yard. Man all the halliards, lower boom topping-lift, forward-guy, in-and-out jiggers, tacks, outhauls; tend the sheets, down-hauls, and clewlines. *Haul taut!* RIG OUT! SWAY TO HAND! Then, HOIST AWAY!**

In sailing with the wind directly aft, many of the sails are becalmed by those abaft them; the sails on the mizzenmast keeping the wind from those on the main, which again becalm those on the foremast. The mainmast acting more directly upon the centre of the vessel, should feel the full force of the wind, for which reason you may furl the mizzen topgallant sail, clew down the mizzen topsail, and haul up its reef-tackles and buntlines. This is termed *scandalizing the mizzen*.

With the wind aft, if the sea is not perfectly smooth, a vessel will roll more than if the wind were on either side. Care should be taken to keep the yards steady, by setting well taut the lifts and burtons.

It is a general rule, in trimming the yards for a shift of wind, when the wind draws aft, to brace *in* the after yards

* Bracing in with stun'sails set, be very careful to clap on the stun'sail halliards, lifts and burtons, and top up as the yards come in. Also keep a strain on the after-guy, boom-brace, and topmast stun' sail tack.

** With stun'sails both sides, *passaree the foresail*, by means of a rope on each side, secured to the clew of the foresail, and rove through a bull's-eye on the lower boom.

436

first; and when it hauls ahead, the head yards should be braced *up* first.

When the yards are square in port, the lifts should be marked by the captains of the tops and mast-men, so that they may, by these marks, always be squared at sea when before the wind, or in coming to anchor; for studding-sails will never set properly on both sides unless the yards are square by the lifts; and in coming to anchor, after the yards are clewed down and braced square, a ship presents a miserable appearance with the yards topped up in every direction.

BRACING UP.

The Wind Hauls Forward. Having the wind aft, and all the sails set to the best advantage, the wind hauls forward on the starboard side, until she is close-hauled; proceed to shorten and regulate the sails, and trim the yards, as the wind hauls.

The wind is now on the starboard quarter, the port studding-sails, from the eddy wind out of the topsails, topgallant sails, and royals, are lifting. *Stand by to dip the port studding-sails!* Having men on the lower, topsail, and topgallant yards; while you lower on the halliards, they haul down on the inner leeches of the studding-sails, and dip the yards forward; then, HOIST AWAY! and now, the studding-sail yards being forward of the sails, the eddy wind has no bad effect upon them. Hoist the mizzen topsail, set the mizzen topgallant sail and royal and the flying jib.

Dipping lee topgallant studding-sails is not recommended.

When bracing forward, the officer of the deck usually trims the fore yard himself, directing the officer of the forecastle to *Trim the upper yards!*

The Wind still Hauls Forward. It becomes necessary to brace up a little by the port braces. *Stand by to take in all the port studding-sails!* Having everything manned, *Haul taut!* CLEW UP! LOWER AWAY! HAUL DOWN! RIG IN! The booms being in, and alongside, studding-sails in, the men making them up to stow away, *Man the port braces, forward guy and fore tack!* Attend the starboard braces, studding-sail tacks, outhaul, and after guy, and let go the lee lower lifts, BRACE UP! *Haul forward the fore tack!* Trim the upper yards, and lower boom by the fore yard. *Man the main sheet and spanker outhaul!* Let go the

main buntlines and leechlines, and have them well overhauled. *Ease down the lee clew-garnet, HAUL AFT! Clear away the brails! HAUL OUT!* Trim aft the jib sheet!*

* Or, set the spanker (as it is taken in) with the *weather* clew of the mainsail.

437

or if the jib had been hauled down, *Man the jib halliards! Clear away the downhaul! HOIST AWAY! Haul taut the weather lifts and braces! Haul out the studding-sail tacks!*

The Wind Hauls Abeam. *Stand by to take in the lower studding-sail!* When ready, *Haul taut! CLEW UP! Lower away! HAUL IN!* Get the lower boom alongside, brace up a little the yards, overhauling the lee lower lifts. *Man the main tack! Ease down the weather clew-garnet, HAUL ABOARD! Trim aft the jib sheet, fore, main and spanker sheets.*

The wind still hauls, being now forward of the beam; brace the yards sharper up, attending the studding-sail tacks, and overhauling well the lee lifts; haul close down the fore and main tacks, and flat aft the sheets; haul aft the spanker sheet; then haul taut the weather braces, and weather lower lifts.

The wind still hauling the studding-sails lift; *Stand by to take in the studding-sails, royals and staysails!* When ready, *IN ROYALS! Lower away, haul down, RIG IN!* Make up and stow away the studding-sails, trice up the studding-sail gear, and get the burtons off the yards. Trim the yards and sails, and haul the bowlines fore and aft. You are now as you were at the commencement, but on a different tack. Weather permitting, leave the royals set.

CALM.

The yards are braced up on either tack, and the wind has died away until it is perfectly calm.

Haul up the courses, brail up the spanker, haul down the jib, and counter-brace the yards, either by bracing around the head yards, or the after ones. In this position she is ready for any wind that may spring up. If there is any swell on, furl the light sails to save them from chafe.

Suppose, for instance, the head yards are braced up by the starboard, and the after yards by the port braces, helm amidships. If the breeze strikes her:

On the starboard bow: Port the helm, hoist the jib starboard sheet aft; when the after yards fill, brace around the head yards, shift over head sheets. Fig. 490.

On the starboard beam: Hoist the jib, port sheet aft; brace around the head yards at once. Fig. 491.

On the starboard quarter: Brace in the after yards, trim the head yards by the main, make sail. Fig. 492.

438

On the port bow: Starboard the helm for sternboard, hoist the jib, port sheet aft, square the (Sails on fore not aback.) after yards. When the fore topsail fills, right the helm and brace up the after yards. Shift over the head sheets. Fig. 493.

On the port beam: Hoist the jib, starboard sheet aft, brace around the after yards at once. Fig. 494.

On the port quarter: Trim the after yards first, then the head yards by the main, make sail. Fig. 495.

If the breeze strikes her ahead, then-

To pay off to port: Port the helm for sternboard, hoist the jib, starboard sheet aft. When she has fallen off sufficiently, shift over jib sheet, **LET GO AND HAUL!** Fig. 496.

To pay off to starboard:

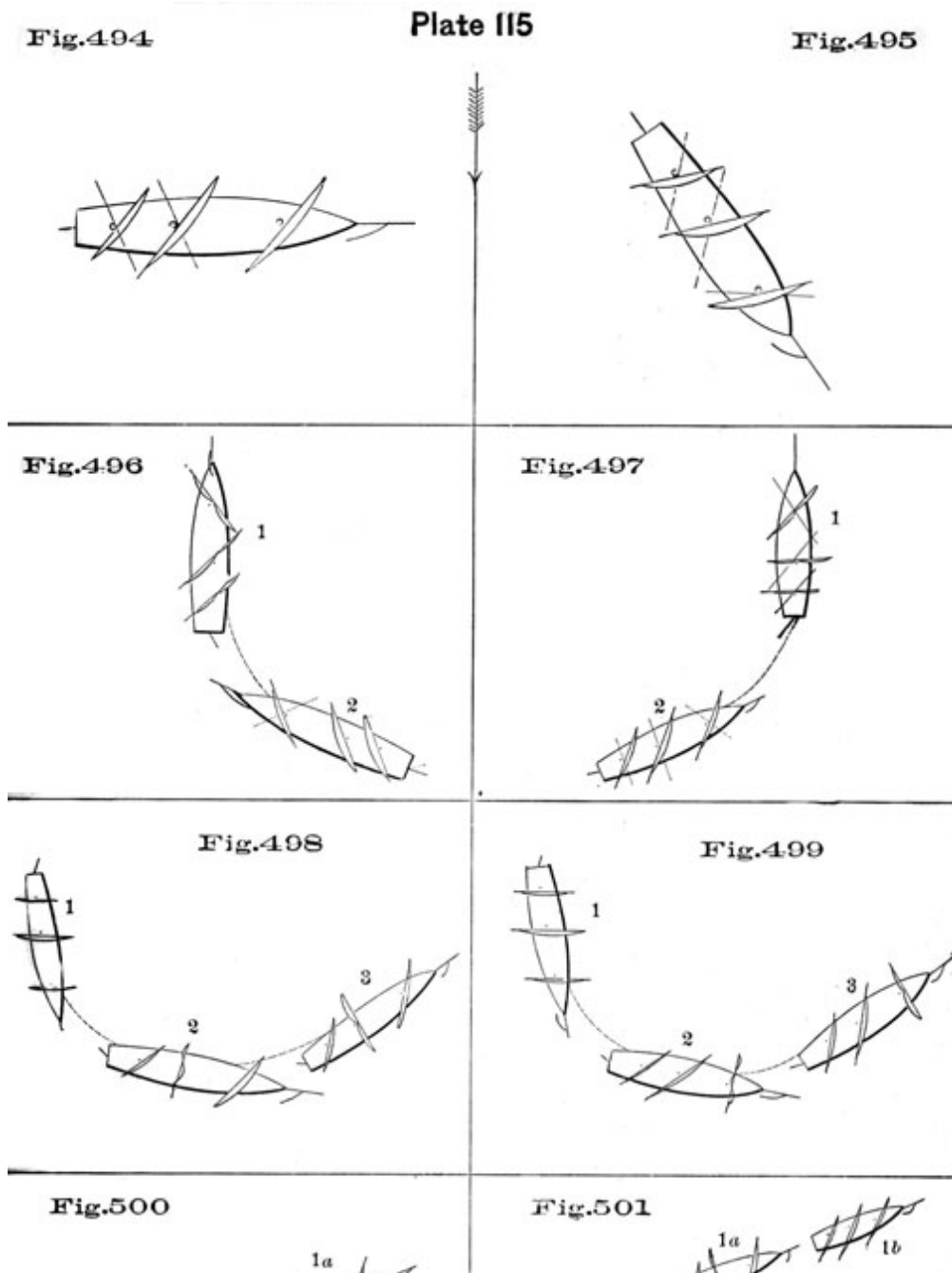
Starboard the helm for stern-board, hoist the jib, port sheet flat aft, brace around briskly the head yards, square the after yards. As she goes off, brace up the after yards, and at the proper time, LET GO AND HAUL! shift over the jib sheet. Fig. 497.

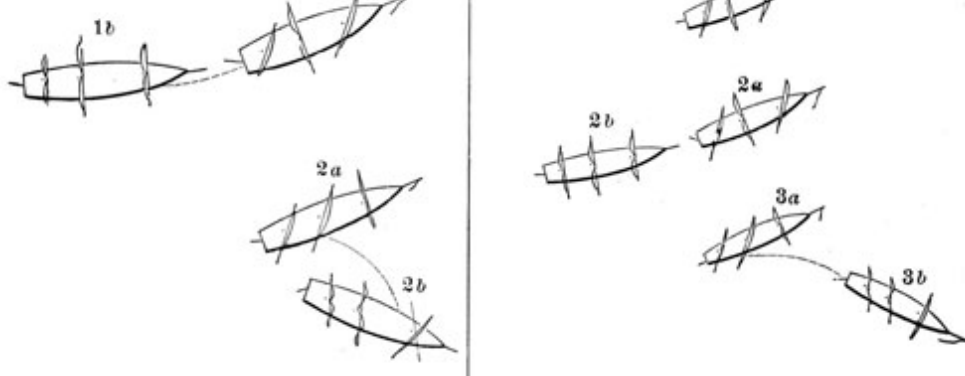
So you have your vessel, by either process, immediately under command; as soon as she gathers headway, bring her to her course, or by the wind, using the spanker to bring her to, and setting the courses to suit circumstances.

ATTRACTION OF VESSELS

TO EACH OTHER, AND OF VESSELS TO THE LAND.

If vessels should be very near each other, though it may be a perfectly dead calm, and the sea as smooth as glass, and even the vessels broadsides to each other; still, experience teaches us, that they will gradually approach until collision takes place. Though the sea may be as smooth as described, still it will always have more or less undulating motion; therefore, the sooner and the more the heads of the two vessels can be brought in opposite directions, the better they will keep clear, because whatever longitudinal motion a vessel receives, has the tendency of making her forge ahead. In the same way, a vessel becalmed near the shore





will gradually approach it unless she can be headed to seaward, to do which it may be necessary to send the boats ahead to tow round. If a vessel is required to be towed round quickly, let all the force of boats be put on forward; we mention this, because we have several times seen them divided, one half towing aft, and the other forward, thereby losing the long lever of the jib-boom. It has been remarked, that when large vessels have been set on fire in calm weather, that it has occasioned light airs of wind to blow directly on the fire. This may perhaps be worthy of notice when shipping is on fire, as the change of light breezes directly out of port to the same breezes directly in, may be of consequence, unless steam is up, in working your own vessel clear of the danger.

CHAPTER XXVI.

TWO OR MORE VESSELS COMMUNICATING AT SEA-HEAVING TO-FILLING AWAY-SQUALLS-MAN OVERBOARD-SOUNDING.

IN the previous chapter, we counter-braced the yards in a calm to prepare for a breeze, but yards are frequently braced in this manner, with a breeze, for the purpose of *heaving to*; in any case where you may wish to remain stationary.

The most common practice in vessels sailing alone, is after hauling up the mainsail, to brace square the main yard-that is, yards on the main mast-having the fore and cross-jack yards braced full, foresail, spanker, and jib, set. Though the sails on the main mast are aback, she will range ahead slowly.

To stop her way still more, brace the cross-jack yards square, haul up the foresail and put the helm a-lee; she will rarely range ahead under this arrangement of the sails, but will fall off and come to, which you may regulate by easing off, or hauling aft, the spanker and jib sheets.

Or you may brace abox the head yards, and keep the after ones full. The after sails will keep her by the wind, while the head sails will deaden her headway.

It must depend entirely upon circumstances which method is resorted to.

Two vessels communicating, the weather one braces aback her main yard, the lee one her head yards; then, on any sudden emergency, as a squall, the weather one throws all aback and drops astern, while the lee one shivers her after yards, fills her fore topsail, and falls off. Fig. 500, Plate 115.

If there are *three* vessels, the centre and weather ones back their main yards, and the lee one as before; then, in case of necessity, the weather one fills her after yards and shoots ahead, the centre one backs astern, and the lee one proceeds as before. Fig. 501.

Sailing in squadron in "order of sailing," those vessels which have the advantage in speed over others, are obliged frequently, besides reducing sail, to back the mizzen topsail, for the purpose of keeping in their stations. This is

frequently done in preference to furling royals and topgallant sails. A fast-sailing vessel will sometimes keep her station for hours, with her mizzen topsail aback.

TO HEAVE TO,

HAVING THE WIND AFT, OR ON THE QUARTER.

After hauling up the courses, commence as in bringing to the wind, brace the mizzen topsail sharp up, put the helm down, and when the spanker will take the right way, haul it out. Keep the main topsail square, and meet her, as she comes to, with the helm, and by bracing up the head yards, and hauling aft the head sheets. Fig. 498, Plate 115.

UNDER SIMILAR CIRCUMSTANCES,

TO HEAVE TO WITH THE FORE TOPSAIL TO THE MAST.

After hauling up the courses, brace up the main and mizzen topsails, when you put the helm down; keeping the head yards square, and hauling flat aft the jib-sheet. It may be necessary to meet her with the helm, and ease the spanker sheet, before she loses her headway, to prevent her coming around or going about. Fig. 499, Plate 115.

If a vessel has a rapid headway when the necessity for heaving to occurs, settle down the topgallant sails and royals, or clew them up; for these sails, when thus thrown aback, receive the full impulse of the wind, increased by the headway of the vessel, and the mast thus pressed has not a sufficient support from its stay.

To Fill Away, after lying to with the main topsail to the mast: *Right the helm! haul aft the head sheets!* and board the fore tack. As she falls off, brace up the after yards, set the mainsail, and trim to the course. If from lying to with the fore topsail to the mast: *Right the helm!* shiver the after sails and haul aft the jib-sheet. As she falls off, brace around the head yards. Meet her with the helm, and trim to the course.

In the foregoing cases, vessels are said to be "*Lying to with the main topsail to the mast;*" "*Fore topsail to the mast;*" "*After yards aback;*" or, "*Standing on with the mizzen topsail aback.*"

Ships running with the wind aft may decrease their speed by "bracing by," thus spilling the wind out of their sails.

SQUALLS.

When a modern vessel, close-hauled, is to be handled during a squall, the weight of evidence is in favor of her *luffing* and reducing sail with all possible dispatch.

The tendency of the vessel is to luff of herself, as the resistance under the lee bow, is greater than that under the opposite bow, in the ratio of the ship's inclination. Moreover, if the ship puts her helm up immediately, sail cannot be shortened till the wind is abaft the beam, to reach which she must pass a point where the whole force of the squall will be exerted upon her.

A long modern ship is slow in paying off, and would hang at this dangerous point even longer than a short old-fashioned vessel.

An argument against luffing is the danger of getting taken aback. But the luffing should be done with a steady helm, being quick to meet her when she trembles.

This recalls the point that, when close-hauled, the after yards should always be in sufficiently to have their

sails touch, while, at the same time, the head yards stand full.

The vessel being under reduced canvas, and luffing to the squall, should it then come so heavy as to endanger her spars, she may go off by letting fly the lee topsail sheets, and clewing up the mizzen topsail.

A vessel running free when struck by a squall, should keep away, reducing sail as necessary.

Attention is called to the value of trysails in squally or heavy weather.

These fore-and-aft sails can be carried when courses have to be hauled up. When set, they assist in giving the ship that headway without which her rudder is of no use.

BY THE WIND UNDER ALL SAIL,

TO REDUCE SAIL TO A SQUALL.

Take in the royals, flying-jib, mainsail, and spanker. Take in topgallant sails, clew down the topsails, haul out the reef-tackles, haul up the buntlines, and belay the topsail clewlines. Set fore topmast staysail and haul down the jib. Receive the squall under this sail. Have a hand by the fore sheet.

If the squall comes so heavy as to endanger your spars, let fly the lee topsail sheets; clew up mizzen topsail, up helm, ease off fore sheet to relieve the pressure under the lee bow, and run before the wind. Clew up fore and main topsails, and haul up foresail.

443

Haul by the wind and make sail after the squall has passed.

If by the wind under topsails and foresail you are struck by a squall, clew down the topsails, *luffing to touch the leeches*. The helm must be carefully attended.

STRUCK BY A SQUALL, GOING LARGE.

Sailing with the wind on the starboard quarter, under royals, flying-jib, staysails, and all starboard studding-sails, you are struck by a heavy squall.

The first and most important thing to be done is, to get your vessel before the wind, which destroys greatly its force, and becalms many of the sails; and the next is, to reduce sail as expeditiously as possible.

Hard up! LET GO THE MAIN AND SPANKER SHEET, AND OUTHAUL! Clew up the royals and topgallant sails, and haul down the topgallant studding-sails and flying-jib, clew down the mizzen topsail, haul up the mainsail and spanker, then take in the lower and topmast studding-sails, and haul down the staysails, rig the booms in, and take the burtons off the yards. When before the wind, right the helm, clew down the topsails, haul out the reef-tackles, and up the buntlines, haul down the jib and hoist the fore topmast staysail. In the meantime, furl the topgallant sails and_ royals, and stow the light sails; and you may now run before the squall until it moderates, or bring by the wind and reef, before keeping on your course.

The lower and topmast studding-sails assist in paying her off, and should be kept on if possible, until she is before the wind, for a vessel in a squall is apt to fly up into the wind, unless means are taken promptly to prevent it by the helm and sails.

In taking in the spanker quickly, when going large, haul down the head before starting the foot outhaul. This makes the sail much easier to handle.

REMARKS ON SQUALLS.

In most cases an officer who keeps a vigilant watch can see the approach of a squall and anticipate it by reducing sail and be ready to brace yards and meet it; for rarely do squalls occur without something to mark their approach—either the appearance of the clouds and horizon or the commotion on the water, the

latter cannot be mistaken and invariably marks the advance of a sudden and violent squall.

No part of the horizon should escape his observation during the watch even in the finest weather with a steady

444

breeze. It will encourage a habit that must turn to good account, and never be a useless one; he may see by this, the approach of a squall from a point directly opposite to the breeze, which appears to be a steady one, and prepare himself by reducing sail in time.

Too much cannot be said in censure of an officer in charge of the deck, intrusted with the safety of a public vessel, and the lives of hundreds of persons, who, performing his duty negligently, allows a squall to strike him without seeing its approach, and consequently unprepared to meet its effects; by allowing other matters to occupy his thoughts and attention during his watch, he is thrown entirely off his balance at any unusual occurrence, creates, by his manner and conduct, confusion among the men, and losing their confidence, at the same time loses their respect, and proper deference to his orders.

Never trust a squall which cannot be seen through, for when a heavy squall strikes the ship, you can seldom reduce sail without losing it.

MAN OVERBOARD.

With the Wind Abeam or forward of the Beam.

The moment the cry of "man overboard" is heard, order:

HARD DOWN!

LET GO THE LIFE-BUOY!

As she comes to, issue the following orders distinctly and in a manner that will cause instant obedience:

Silence fore and aft!

CLEAR AWAY THE LEE CUTTER!

Main clew garnets and buntlines!

Weather main and lee crossjack braces!

Clear away the after bowlines!

UP MAINSAIL! BRACE ABACK!

The moment the lee braces and bowlines are let go, the yards (from being already in the wind) will fly around of themselves; then keep the head yards full to steady her, while the after ones stop her headway.

While this is being done, the boat is ready for lowering, with a crew and officer in her. *Lower away!* and direct them which way to pull.

In smooth water, and when the boat has but a short distance to go, remain hove to and await the return of your cutter, making all preparations for hoisting. With a fresh breeze and heavy sea, bear up after the departure of the life boat, run down to leeward of her and heave to on the same tack as before, in readiness for hoisting.

In all cases of sudden heaving to, light well up the head sheets.

With the Wind Aft the Beam.

Assume the ship to have the wind on the starboard quarter, with the starboard studding-sails set, the principle being the same, however, under any disposition of canvas with the wind abaft the beam.

Luff to *with the head yards to the mast*, using the following orders:

HARD DOWN!

LET GO THE LIFE BUOY!

CLEAR AWAY THE LEE CUTTER

Lee main, weather crossjack braces!

BRACE UP!

Let fly the stunsail tacks and sheets!

CLEW UP THE LOWER STUNSAIL!

Fore and main clew garnets and buntlines!

UP COURSES!

By this arrangement of canvas the ship is hove to with the head yards to the mast, and may be held steady till the return of the boat. Let the officer of the forecastle haul down the stunsails and get things to rights forward. The booms may be left out.

In this case the boat pulls off the weather beam.

Wind aft, and Studding-sails both sides.

Round to on either tack (the particular one determined in the mind of the officer when taking charge of the deck), brace up the after yards and luff to with the head yards square.

Give the following orders, if to come to on the starboard tack:

HARD A-PORT!

LET GO THE LIFE BUOY!

CLEAR AWAY THE PORT CUTTER!

Man the port main, starboard crossjack braces, spanker outhaul!

BRACE UP! HAUL OUT!

Let fly the starboard studding sail tacks! CLEW UP THE STARBOARD LOWER STUDDING SAIL!

Take in the lee stunsails as fast as possible, then the weather ones. Up courses and reduce sail as necessary.

The boat pulls off the weather beam.

The best authorities agree that a smart working ship, which is sure in stays, should go about on losing a man overboard with the wind abeam or forward of the beam; leaving the main yard square on the other tack and lowering the boat in stays.

In such a ship, when on a wind, order: *Ready about!* LET GO THE LIFE BUOY! CLEAR AWAY THE WEATHER CUTTER!

Proceed as in tacking. At the order: RISE MAIN TACK AND SHEET! haul up the mainsail; keep fast the fore tack to pay her around. Make a late "maintopsail haul" or the main brace may carry away; leave the main-yard square. Shift the helm for sternboard, and when ready, RISE FORE TACK! and LET GO AND HAUL! Do your utmost to get the boat lowered before the ship gathers sternboard. If this proves impossible, you may save trouble by waiting till the stern-board ceases before lowering.

The great merit of this plan is that the ship when around drifts right toward the man and the boat.

If the boat is in distress, or her crew exhausted, the ship will be in position to afford prompt assistance.

Unfortunately this practice is limited to vessels that can be relied upon to tack, and therefore cannot be adopted by the average modern steamer cruising under sail.

Particular attention may now be directed to other matters connected with this important manoeuvre.

The life-buoy look-out should watch for the appearance of the man before dropping the buoy. A cool hand will drop the buoy within a few feet of the man-another will either not let it go at all or drop it before the man reaches the stern. The buoy dropped, the look-out should keep the man in sight until the persons specially detailed for this purpose reach their stations in the mizzen rigging, and can get the bearing from the look-out.

It is not entirely advisable for the life-buoy look-out to leave his station himself and go into the rigging-as he may be required to let go the other life-buoy-in case of an accident to the life boat when lowering.

In coming to the wind in a fresh breeze, clew up the royals and settle the topgallant halliards.

In bracing around, letting fly gear, &c., do not forget to warn men on the yards to look out for themselves.

Be smart in hauling up the mainsail; if you allow the main-yard to fly square before the mainsail (or at least one of its clews) is out of the way, it will defy the efforts of the whole watch to haul it up.

There is generally more mischief done in lowering the boat too soon than by waiting for the proper moment. Lower when the ship has slight headway, and at all events before she gathers sternboard.

If sailing in squadron, make the preconcerted "accident" signal as soon as possible, and at night run up your position lights without delay.

In giving your orders, substitute the words, STARBOARD and PORT, for *lee* and *weather*, whenever practicable, especially in manning the boat and gear. The cry of man overboard brings all hands on deck, and if greeted with

unmistakable orders they know what to do and where to go. This precaution is of special value on a dark night, or when the ship is nearly before the wind.

Every ship should have men told off for the following purposes:

To tend the life-boat falls.

To keep the man in sight.

To hoist and tend signals of "Pull to port;" "Pull to starboard;" "You go well;" and to display lights or fire rockets showing ship's position.

A Very signal fired in the direction of the man will often reveal his position in the water, if not too distant.

Success in saving the man depends on the coolness of the officer of the deck and of the look-out at the life-buoy, and upon the normal condition of the boats.

The officer of the deck should-

First. Keep cool himself and preserve order.

Second. Let go the buoy and keep the man in sight.

Third. Put the helm down.

Fourth. Heave to.

Fifth. Lower the life-boat.

Sixth. Get matters to rights and prepare for hoisting the boat.

Life-Buoys. The service life-buoy consists of two oblong copper tanks, connected by cross-pieces through which passes a central spindle. At the upper end of the spindle is placed a port-fire. A flat piece of iron at the lower end supports the feet and keeps the buoy upright in the water. It is recommended to paint the buoys with phosphorescent paint.

The buoy is attached to the stern by a chain slip. A handle inboard disconnects the slip when pulled upon, and drops the buoy; another handle, close to the first, fires the port-fire. The handle to *port* is for the *port*-fire.

Many ships overcome the clumsiness of this arrangement by adapting the action of one handle to disconnect and set off the port fire simultaneously. The buoy is primed by the gunner every night at sunset, and the primer removed again by him the next morning. A *personal* duty.

To float on this buoy, place the feet on the weight, grasp the spindle abreast of the copper tanks with one hand, and above with the other hand; in this position you will float with your head out of water. By attempting to get as high out of the water as possible, the buoy will invariably be capsized.

Circular life-buoys should be distributed about the upper deck, for in the long modern ships a buoy thrown out from the gangway often falls closer to the man than one thrown from aft.

To use the circular buoy, the man slips it over his head and rests his arms upon it on either side.

A few exercises in picking up buoys and lowering lifeboats under various circumstances at sea will accustom both the officer of the deck and the watch to that kind of work.

It would be well, also, when the crew are sent in bathing, to drop the life-buoys and allow the men to form some idea of the manner in which they are to be used, and of their sustaining power.

SOUNDING.

In a light breeze, with the wind free and all sail set, soundings may be taken without reducing sail, thus Luff the ship up; if the lower stun'sail is set haul up the clewline, and keep the sails lifting, without allowing them to catch aback, which can readily be done by a proper management of the helm; she will lose her headway sufficiently for the purpose, and still be under control of the helm. The soundings being taken, keep her off to her course, and haul out the lower stun'sail.

The operation of obtaining soundings, particularly when going large, affords a fine opportunity for the display of skill and judgment in handling a ship. Celerity and certainty are generally aimed at, but very frequently is the latter needlessly sacrificed to the former. Full preparation should be made first with the lead and line. The sails and helm must then be managed so as to bring the ship as nearly stationary as possible without endangering the spars. As soon as the headway ceases, or nearly so, get a *fair up and down cast*, and fill away.

The common error is to get a cast with too much way on. Instead of saving, this only wastes time, for if the soundings are necessary at all, they should be determined correctly.

On a wind, haul up the mainsail and back the main topsail. In addition to this, the mizzen topsail may be thrown aback if found necessary to deaden the ship's way.

CHAPTER XXVII.

REEFING-TURNING OUT REEFS.

Reefing and Hoisting- When it becomes necessary to reduce sail by reefing topsails, if all hands are to be employed, direct the boatswain to call:

REEF TOPSAILS! The men being on deck:

Man the topsail clewlines and buntlines, weather topsail braces! Hands by the lee braces, bowlines, and halliards!

A few hands take through the slack of the reef-tackles.* When ready-

Clear away the bowlines, round in the weather braces! Settle away the topsail halliards! CLEW DOWN! Brace the topsail yards in so that the lee topmast rigging may not prevent them from being clewed down to the cap; haul up the buntlines, and the slack of the reef-tackles while the yard comes down; and when it is down on the cap, steady the yard by the lee braces, and haul taut the halliards. (The latter precaution is too commonly neglected.)

HAUL OUT THE REEF TACKLES!

HAUL UP THE BUNTLINES!

ALOFT TOPMEN! TRICE UP! LAY OUT! TAKE ONE REEF! Light out to windward. Pass the weather earing, rousing the reef-cringle well up; then haul out to leeward; hauling the reef-band well taut; pass the lee earing and tie the points or toggle the becketts.

While the men are reefing, luff the ship up and spill the sail, that they may gather it up readily.

LAY IN!

Stand by the booms!

DOWN BOOMS! LAY DOWN FROM ALOFT! *Man the topsail halliards! Let go and overhaul the rigging!* Clear away the buntlines, clewlines, and reef-tackles, and have them lighted up. *Tend the braces!* Let go the lee ones, and stand by to slack the weather ones. *Set taut!* HOIST AWAY THE TOPSAILS! When up to a taut leech, *Belay the topsail halliards!* Trim the yards, *Steady out the bowlines!* and pipe down.

Frequently topgallant sails are set when about to reef

* If the reef-tackles reeve through a sheave in a treble quarter-block under the topsail yard, they act as downhaul tackles when hauled upon, and should be manned. But avoid endangering the yard-arms by putting undue strain upon such reef-tackles while clewing down.

29

450

topsails. If you intend to set them again after the topsail is reefed, clew the sail up, and after the topsail is reefed and hoisted, sheet home and hoist the topgallant sail over the single reef.

If the wind still increases, and it becomes necessary to reduce sail still further, clew up and furl the topgallant sails, then take a *second* and a *third* reef, proceeding as in the first, having each successive reef-band immediately below the preceding one.

And to reduce sail still further, by taking the last or close reef, pass the earings abaft and over the yard, bring the reef-band under the yard, and covering the other reefs. It will be necessary in this reef to haul the reef-tackles close up, to do which you will be obliged to start a little of the topsail sheets, or to brace in a little of the lower yards.

After taking the third reef in the topsails, it is advisable to get *preventer braces* on the weather topsail yard-arms, particularly if the braces are much worn.

After hoisting a close-reefed topsail, haul taut the reef-tackles, so that they may bear a strain to relieve the reef earing, and be particular that the yard is hoisted clear of the lower cap. Send the men down from aloft, haul home the sheets, trim the yards, and haul the bowlines.

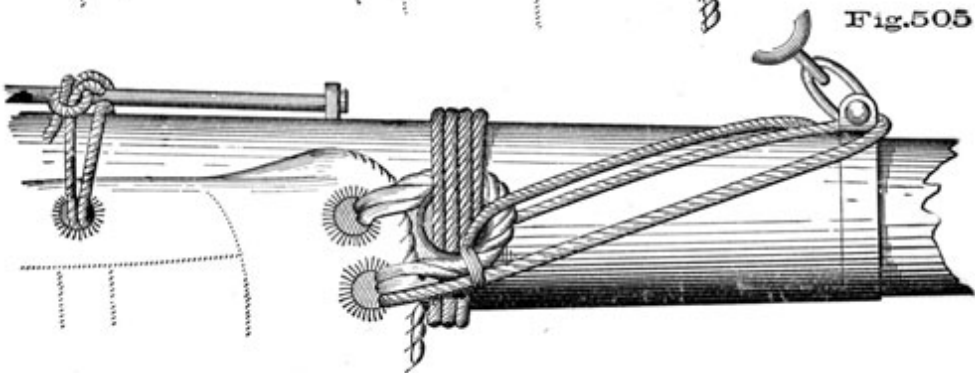
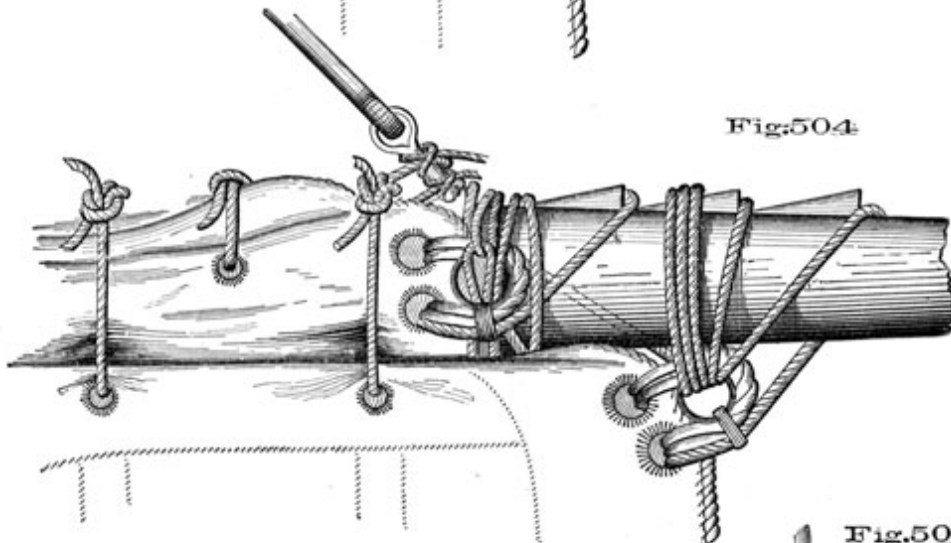
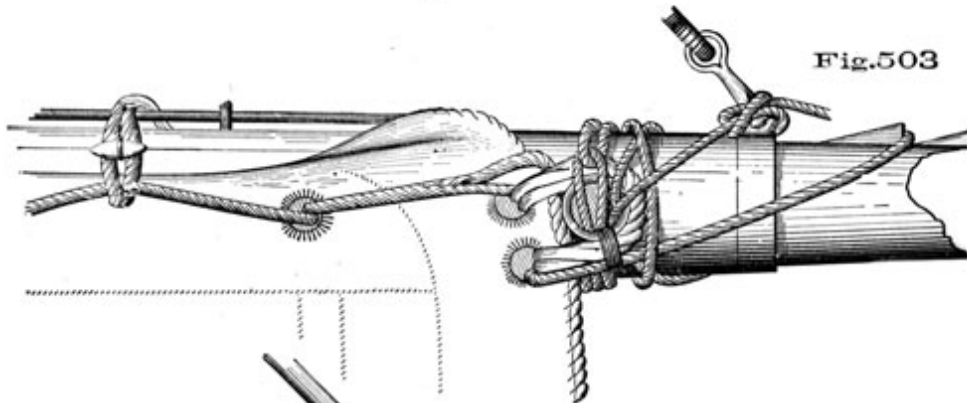
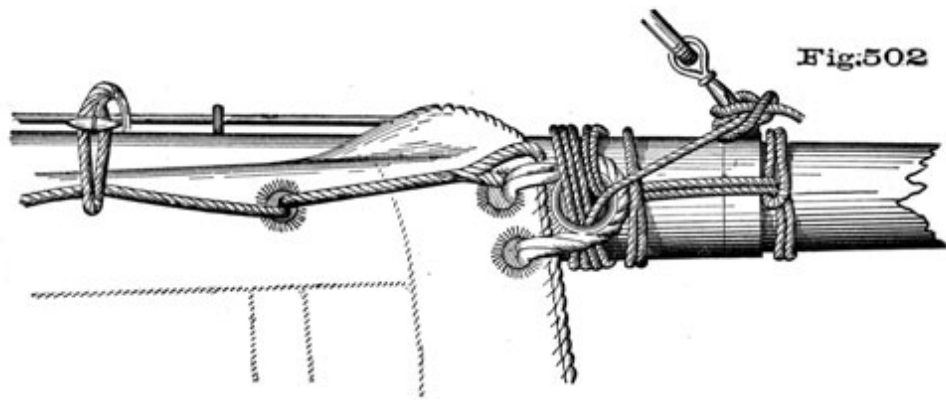
The mizzen topsail is generally furled when the fore and main are close reefed.

To Reef Topsails before the Wind, you may, by putting the helm either way, and bringing the wind abeam, clew the yards down as the sails lift, and keep her in this position until they are reefed; or if you wish to, continue on your course, wind blowing very fresh, *brace by*, spilling the wind out of the sails.

To Reef a Course. Having the reef-pendants hooked to their cringles, on the leeches of the sail, hook the clew-jigger to the thimble in the upper end of the pendant; *Man the clew-garnets, buntlines and leechlines!* and haul the sail up as in a fresh breeze. Haul well taut both lifts. HAUL OUT THE REEF-TACKLES! slacking the clew-garnets, if necessary, to get them well up. LAY ALOFT LOWER YARDMEN! *Man the boom tricing-lines!* TRICE UP, LAY OUT AND REEF! Proceed in reefing as in taking the first reef in a topsail, being careful to secure every reef point to the jack stay. LAY IN! DOWN BOOMS! LAY DOWN FROM ALOFT! Let go and overhaul the reef-tackles, and set the sail.

Topgallant sails have sometimes reef-bands fitted with points, and may be reefed as you would reef a topsail, but this is rarely done. When it blows too fresh to carry a whole topgallant sail over a single-reefed topsail it is time to furl it.

A topmast studding-sail, when set with a reefed topsail before the wind, may also be reefed; this is done on deck before setting the sail.



Reef Earrings - Reef Points and Beckets. In reefing, as soon as the men are on the yard, the sail is picked up with both hands, the men facing to leeward and hauling out to windward. The weather earing being passed, *Haul out to leeward!* passing the lee earing in the same manner as the weather one. Haul the reef-band well taut, and turn the folds (*dog's ears*) of both leeches in between the sail and the yard.

To pass a bull earing for the first or second reef of a topsail, Fig. 502, Plate 116. The end passes from aft forward through the reef-crinkle; haul the cringle well up on top of the yard, then take one round turn of the earing around the yard and outer parts *without* passing through the cringle, after which take three turns round the yard and through the cringle, hitching the ends to the lift close down to its eye-bolt.

The first turn is taken outside the cringle to jam the thwartship parts and keep the cringle from sagging down.

For description of a bull earing, see *Earrings*, under SAILS, Chapter X.

To pass an ordinary earing for a topsail. For the first reef, if so fitted, as in Fig. 503, Plate 116, take the earing up from the sail and pass it on the forward side and over the yard around the inboard cleat, through the cringle, then take one turn around the yard outside the cringle, to jam the outer turns. Then reeve the *bight* of the earing through the cringle from aft forward, and pass the end from the cringle under the yard up over and through the bight, then back over the yard and through the cringle from underneath the yard. Slue the cringle well up, pass sufficient turns to secure, expend the end round the yard, finally taking a half-hitch around the lift close down.

The second and third reef earrings are passed in the same way, using the outer cleats, and with additional outer turns if required.

First and second reef earrings are now generally bull earrings, as described above.

The *fourth* or close reef earing is passed similar to other (ordinary) earrings, with the exception of taking the *first* turns on the *after* instead of the forward side of the yard. Fig. 504, Plate 116.

If the close reef were fitted with becketts, it would be taken like the others, and the first turns of the earing taken forward, as usual.

Reef earrings of a course. The course being hauled up, the first reef earing is then passed from *forward aft* around the lift bolt, back over the top of the yard and through the cringle. Take the inner turns through the cringle and around the yard, the same as for a topsail, hitching the end around the brace-block bolt. Fig. 505, Plate 116.

The second reef earing is passed in the same way.

The use of outer turns of a reef earing is merely to keep the head of the sail on a stretch, the *inner* turns taking the whole strain of the leech when the sail is hoisted and bowline hauled.

Reef points of a topsail. The reef earrings being secured, pass the after reef points up from under the yard and clear of the topgallant sheets (i.e., between the topgallant sheets and the yard), pull the sail well up forward, and join the forward and after parts of each point with a square knot on top of the yard. Be particular that the reef points are all tied.

Reef points of a course are taken with a round turn around the jackstay, and each pair square knotted forward of the jackstay.

Reef becketts have their tails passed through the reefing jackstay on the sail, and toggled to their own parts, as soon as both earrings-are passed.

To Shake or Turn a Reef out of a Topsail. *Settle a little of the topsail halliards! Haul taut the reef-tackles and buntlines!* to take the strain off the leeches of the sail and reef-earring. Send aloft the sail loosers. Cast off the reef-points or becketts from the slings, as they lay out, and have the earrings ready to

ease away; when the reef-points are all clear, EASE AWAY! LAY IN! LAY DOWN FROM ALOFT! *Let go and overhaul the rigging!* Reef-tackles, buntlines, clewlines, topgallant studding-sail tacks, and topgallant sheets are overhauled. *Man the topsail halliards! Tend the braces!* HOIST AWAY THE TOPSAILS! Trim the yards, and if on a wind, haul the bowlines.

To Turn a Reef out of a Course, proceed as in a topsail, easing off the tack and sheet to relieve the strain on the leeches of the sail, while you are hauling taut the reef-tackles; when done, haul aboard the tack, and aft the sheet.

GOING LARGE UNDER ALL SAIL,

TO ROUND TO UNDER SINGLE REEFS.

Sailing with the wind on the starboard quarter under royals, flying-jib, staysails, and all the starboard studdingsails,-a signal is made to come to on the port tack, with the main topsail to the mast, under single-reefed topsails.

In obeying this signal, it will be your object to reduce sail, and reef your topsail in wearing. Order the boatswain to call:

SHORTEN SAIL! When ready: *Stand by to take in the stun'sails, staysails, royals and flying-jib!* When everything is well manned, order, *Haul taut!* IN STUN'SAILS AND ROYALS, DOWN STAYSAILS AND FLYING-JIB! Rig in and get alongside the booms, take the burtons off the topsail yard,

453

and jiggers off the topgallant lifts. Furl the royals, haul down and stow the staysails and flying-jib, make up and stow away the studding-sails.

LAY ALOFT TO FURL THE TOPGALLANT SAILS!

Man the topgallant clewlines, lee main clew-garnet, and buntlines! Spanker brails! When manned, IN TOPGALLANT SAILS! UP MAINSAIL AND SPANKER! Haul the mainsail up snug.

Stations for wearing! And proceed as directed in "Wearing," until the wind is right aft; when, the after yards being square, square also the head yards. *Shift over the head sheets!*

Man the topsail clewlines, buntlines, and reef-tackles! Lay aloft topmen! Settle away the topsail halliards! CLEW DOWN! HAUL OUT THE REEF-TACKLES! HAUL UP THE BUNTLINES! Steady the topsail yards by the braces. TRICE UP! LAY OUT! TAKE ONE REEF IN THE TOPSAILS! Shift over the spanker boom.

The vessel going around, brings the wind on the port quarter; brace up the cross-jack yard, and as she comes to, bringing the wind abeam, meet her with the helm, haul aft the jib-sheet, brace up the fore yard, and haul forward the port fore tack. LAY IN! DOWN BOOMS! LAY DOWN FROM ALOFT! *Man the topsail halliards!* Clear away and light up all the rigging. *Tend the braces!* HOIST AWAY THE TOPSAILS! Having mast-headed the topsails, brace up and trim the fore and mizzen topsail yards. Haul taut the lifts and braces, and pipe down.

Use the spanker, if necessary, to keep the topsails lifting while you are reefing; and when reefed, to bring her by the wind, and keep her from falling off.

After taking in the studding-sails, being in a hurry to perform the remainder of the evolution, merely remove them from out the way of the rigging, and make them up while the topmen are reefing, or after the evolution is completed.

Reefing Topsails and Courses. These evolutions are sometimes performed at the same time, but it is considered more ship-shape to defer reefing the courses until the topsails are reefed and reset. By so doing, the ship is kept more steady while the people are aloft, and under much better command.

Lower yards should be well placed before sending men on them for the purpose of reefing or furling courses. When it becomes necessary to perform either of these operations at sea, there is generally considerable motion; and an attempt to remedy neglect or want of judgment in this particular, by handling the braces while men are on the yards, is always attended with great danger to them, especially in the case of main yard men, who are mostly inexperienced hands.

GENERAL REMARKS ON REEFING.

In clewing down to reef, luff the ship to, with a steady helm, and meet her when she shakes. Clear away the bowlines, settle a little of the halliards, and *then* round in the weather braces. By adopting this precaution, the sails are more easily spilled, and by hauling on the weather braces, they serve not only to keep the yard in, but to bring it down also, which would *not* be the case were the halliards kept fast until afterwards. But have the topsail yard braced well in before settling the halliards away *roundly*, or else the lee topmast rigging will be endangered.

Much depends upon the manner in which the sails are laid for reefing; for this reason it is deemed best by experienced seamen to keep the courses, which should be set, *full*, and to brace the upper yards in, sufficient to make the topsails lay "alive;" or in other words, so that the weather leech will *cut*, as it were, the wind in two, leaving the canvas hanging loose.

If sailing with the squadron in moderate breezes, run the yards in nearly square, or the men will lose time in getting on the weather yard-arm.

Bracing in a topsail yard for reefing, in a fresh breeze, requires great force, and not unfrequently the brace, from being much worn, becomes stranded; as soon as you discover it, put on a good stopper above the strand, man the weather clewline and clew the sail up, bend the lee bowline to the extremity of the lee yard-arm, and get a preventer-brace on the weather one; then, by these, brace in the yard and clew it down; and while you are reeving new braces or splicing old ones, steady the yard by the bowlines and preventer-brace.

When short-handed or working with the watch, clew the yards down, and get all ready for reefing *before starting the men up*; but with all hands, the topmen may be sent aloft at once, and ordered out as soon as the yards are on the cap, the braces steadied taut, and gear hauled up.

In *hoisting sails* after reefing, be careful (particularly if it be blowing fresh) not to "swig" them up too taut, as the reef-bands are apt to be slewed under the yard in consequence, and the sail must be reefed afresh.

In a seaway, and the vessel pitching, do not haul the braces too taut; it endangers the yard and the rigging; the lee braces should be kept slack to allow the yard a little play, but be particular that though the brace is slack, it is securely belayed to its pin.

When double or treble reefing on a wind with courses set, bear in mind that the outer arms of the topsail yards are unsupported, and are unequal to the strain that may be brought to bear on them, by overmanning the reef-tackle.

When the yard is laid, the duty of the reef-tackle is to give the earing men plenty of slack leech between itself and yard; and if it cannot effect this without much straining (and this can easily be judged of by observing the tautness of the leeches *below* the reef-tackles on each side), raise the clews at once with the clewlines, sufficiently for the purpose.

Particular attention should be given to the fore topsail in this respect. The fore yard being braced sharper up than the main, unless the lee topsail sheet is checked a little, the sail cannot be as well hauled up for reefing as the main topsail. Bracing *in* the fore yard is less advisable than checking the lee sheet, as the yards should be kept sharper up forward than aft.

Pull the buntlines well up so as to girt the sail in for the bunt points.

Nothing is gained by permitting the men to get out on the yard for reefing, in a strong breeze, until the yard is laid and the sail ready for them. Yard-arms have been wrung off in the endeavor to make the reef-tackle do all the duty of other gear, and the earing men's lives saved only by a seeming chance.

In reefing at night, in the line, observe if your next ahead and astern have more or less sail than topsails. If you have been sparing them courses, you will be run into; and if they have been sparing them to you, you will run into your leader, unless you are alert.

A few fathoms of the main brace, checked by one hand, will often just regulate the pace and keep the ship in station; and, if let go at the instant, arrest danger.*

After every evolution (especially at night), make the petty officers report their ropes, and also immediately after relieving the watch.

Preventer-brace pendants, made long enough to reach from the yard-arm to the slings, are not only quickly attached to the whips, but the risk sometimes incurred in sending men on the yards greatly diminished. Preventer topsail braces have more drift, and a more downward pull than the standing ones; and, therefore, should never be so taut, or be hauled upon, until the lifts are well up.

The general rule for topsail lift jiggers, is to put them on when the second reefs are taken. And it is good to make a habit of putting the spare parrels and preventer-braces on when the third reefs are taken.

When topgallant yards are sent down on account of weather, unreeve the topgallant sheets, and reeve them through the bowline bridle of the topsails, up before all, and hitch them to the lugs of the tie blocks. They will act like the leechlines of courses when taking in topsails.

* This refers to sailing in line. Hardly too much can be said of the many and great advantages of squadron sailing; the constant rivalry excited among the several ships, making it one of the very highest schools of seamanship.

Reefing a Spanker. Brail up as in blowing fresh, but do not haul up the clewrope. Lower the throat and peak halliards (or tackles clapped on to the pendants, if so fitted), steadying the gaff by the vang. Pass a reef earing through the cringle in the leech and around the foot of the sail; if taken around *the boom*, the foot of the sail cannot be brailed up. Bring down the forward reef cringle and pass a tack-lashing through it. Reef the sail on the foot. The outhaul may be shifted to the reef cringle, but this is not always done. When ready, sway up the gaff till the luff is taut, easing the vang and steadying aft the out-haul. Then haul out the head and get a final pull on the foot outhaul; easing off the spanker sheet as necessary.

To Reef a Trysail. Proceed as above, shifting the sheet block from the clew to the reef cringle.

The old *balance reef* in a spanker, from the close reef cringle diagonally toward the jaws, is rarely used.

A spanker or trysail is frequently set "reefed," by keeping fast the head downhaul, and hauling out the foot only. A few turns of the furling line at the head will assist in keeping it in.

The storm mizzen is a substitute for the spanker set in this way.

CHAPTER XXVIII.

THE WEATHER.-THE BAROMETER.-LAWS OF STORMS.

WIND AND WEATHER.

"Some persons attribute influence to the moon in respect of weather, and say a change may be expected within a few days of the moon's phases. But the interval between one and another phase of the moon is but seven days, and 'a few' of these days *must* be a time near one phase or another. Accidental coincidences are generally allowed to influence the wind, because, when they occur, they mark any event more particularly. Similar to these are the prejudices against sailing on Friday, which used to be so general."

Continued comparisons of changes of weather or wind during many consecutive years, in various parts of the world, have proved decidedly that there is no regular correspondence between the lunar phases and atmospherical changes.

The following are a few of the more marked signs of weather:-

"Weather, clear or cloudy, a rosy sky at sunset presages fine weather; a red sky in the morning, bad weather, or much wind (if not rain); a gray sky in the morning, fine weather; a high dawn, wind; a low dawn, fair weather."

[A high dawn is when the first streaks of morning light appear over a bank of cloud, instead of near the horizon, as is usual when there are no heavy clouds.]

"Soft-looking, or delicate clouds, foretell fine weather, with moderate or light breezes; hard edged, oily-looking clouds, wind. A dark, gloomy blue sky is windy; but a light, bright blue sky indicates fine weather. Generally, the softer clouds look, the less wind (but perhaps more rain) may be expected; and the harder, more 'greasy,' rolled, tufted, or ragged, the stronger the coming wind will prove. Also a bright yellow sky at sunset presages wind; a pale yellow, wet; and thus, by the prevalence of red, yellow, or gray tints, the coming weather may be foretold very nearly; indeed, if aided by instruments, almost exactly.

"Small inky clouds foretell rain; a light scud, driving across heavy clouds, wind and rain; but if alone, wind only.

458

"High upper clouds crossing the sun, moon, or stars, in a direction different from that of the lower clouds or wind then blowing, foretell a change of wind (beyond tropical latitudes).

"After fine, clear weather, the first signs (in the sky) of change, are usually small, curly, streaked, or spotty clouds, followed by an overcasting of vapor that grows into cloudiness. This murky appearance, more or less oily or watery, as wind or rain will prevail, is a sure sign. The higher and more distant the clouds seem to be, the more gradual, but extensive, the coming change of weather will prove.

"Generally speaking, natural, quiet, delicate tints or colors, with soft, undefined forms of clouds, foretell fine weather; but gaudy, or unusual hues, with hard, definite outlines, presage rain and wind."

RECORD OF WEATHER.

In keeping the Journal, for the sake of brevity, the force of the wind and state of the weather are expressed thus:

WINDS.

- | | |
|--|--|
| 0. Calm. | 7. Moderate gale; double reefed topsails. |
| 1. Light air; just perceptible. | 8. Fresh gales; treble reefed topsails and reefed courses. |
| 2. Light breeze; ship going from one to two knots. | 9. Strong gale; close reefs. |
| 3. Gentle breeze, from two to four. | 10. Whole gale; close reefed main topsail. |
| 4. Moderate; from four to six. | 11. Storm; storm staysails. |
| 5. Fresh; when royals can be carried. | 12. Hurricane; no canvas. |
| 6. Strong breeze; first reef and topgallant sails. | |

WEATHER.

- | | |
|--------------------|------------------------------|
| b. Blue sky. | p. Passing showers. |
| c. Cloudy. | q. Squalls. |
| d. Drizzling rain. | r. Rainy. |
| f. Foggy. | s. Snow. |
| g. Gloomy weather. | t. Thunder. |
| h. Hail. | u. Ugly threatening weather. |
| l. Lightning. | v. Visibility of objects. |
| m. Misty. | w. Wet dew. |
| o. Overcast. | z. Hazy. |

A star (*) under any letter denotes a great degree.

"Cirrus" expresses a cloud, like a lock of hair, consisting of streaks, wisps, and fibres, vulgarly called "mares' tails." "Cumulus," a cloud in dense convex heaps in rounded forms definitely terminated above, indicating saturation in the region of air, and rising supply of vapor from below. "Stratus" is a continuous extended level sheet, but must not be confounded with the flat base of the Cumulus. "Cumulo-stratus," or anvil-shaped cloud, is said to forerun

459

heavy gales. "Nimbus," a dense cloud spreading out into a crown of "Cirrus" above, and passing beneath into a shower.

The amount of clear sky is expressed in all log-books, in tenths, zero denoting a sky completely overcast, and 10 a clear sky.

TABLE SHOWING THE FORCE AND VELOCITY OF THE WIND.

BY SIR W. SNOW HARRIS.

Pressure in lbs. per square foot	Vel'city in miles per hour	Popular Descriptions, and Corresponding Numbers.	Pressure in lbs. per square foot	Vel'city in miles per hour	Popular Descriptions, and Corresponding Numbers.
0.002	0.68	1. Gentle airs, unappr'ciable by gauge	1.042	15	6. Fresh breezes; top- gallant sails.
0.004	1		1.170	16	
0.005	1.06		1.250	16.5	
0.019	2	2. Light airs, just appreciable by gauge;	1.302	17	7. Fresh winds; reefs.
0.028	2.5	would fill the lightest sail of a yacht.	1.430	17.8	
0.032	2.66		1.470	18	
0.043	3		1.563	18.67	8. Moderate gales; treble reefed topsails.
0.052	3.3	3. Light breezes, such as would fill the lightest sails of a large ship.	1.630	19	
0.065	3.8		1.790	20	
0.071	4		1.820	10.14	9. Strong gales; close r'fed topsails and reefed courses.
0.090	4.5		2.084	21.47	
0.100	4.75		2.600	24	
0.112	5		3.126	26.40	10. Gales; close-r-fed topsails, and staysails.

0.130	5.38		3.647	28.52	
0.136	5.5		4.168	30.56	
0.162	6		4.689	32.34	
0.228	7		5.200	34	11. Heavy gales and storms.
0.260	7.6		7.800	41	
0.291	8	4. Moderate breezes, in	10.400	48.2	
0.364	9	which ships can carry all	13.000	53.91	
0.390	9.27	sail.	15.600	59	
0.452	10		20.800	68.18	12. Very heavy gales; great
0.521	10.77		26.000	76.18	storms, tempests.
0.551	11		31.200	83.6	
0.650	12		36.400	90.12	Tornadoes; cyclones;
0.780	13	5. Stiff breezes ; topgallant	41.600	90.34	hurricanes.
0.830	13.6	sails and royals.	52.000	107.7	
0.884	14		62.400	120	
0.910	14.25				

WEATHER PROVERBS COMMON AMONG SEAMEN.

" A rainbow in the morning,
Sailors, take warning;
A rainbow at night
Is the sailor's delight."

460

Morning rainbows are always seen in the west, and indicate the advance of a rain-cloud from that quarter when it is clear in the east. The fall of rain at a time of day when the temperature should be rising is indication of a change to wet, stormy weather.

On the contrary, an evening rainbow occurs when the rain-cloud passes to the east, and a clearing up ensues in the west at a time of day when the temperature has begun to fall, thus indicating a change from wet to dry weather.

Another form of the saying is:

Red sky in the morning,
Sailors, take warning,
&c.,

being based upon the same phenomena.

"The evening red and morning gray
Are sure signs of a fine day;
But the evening gray and morning red
Make the sailor shake his head."

"With the rain before the wind,
Your topsail halliards you must mind;
But when the wind's before the rain,
You may hoist your topsails up
again."

"When the sun sets in the clear,
An easterly wind you need not fear."

Relating to the Barometer:

Long foretold, long last,
Short coming, soon past.

and

First rise after very low,
Indicates a stronger
blow.

Relating to the hurricane months in the West Indies:

June, too soon;
July, stand by;
August, look out you must;
September, remember.
October, all over!

THE BAROMETER.

The barometer, feeling the pressure of the air, shows at once when that pressure is changing. If the pressure at one place on the earth be greater than at another, the air has a tendency to move from the place where the pressure is greater towards that where it is less, and thus wind is caused.

461

A change of weather comes almost always with a change of wind, and the extent of this change of weather depends on the fact of the new wind being warmer or colder, damper or drier, than that which has been blowing. Any conclusions drawn from its movements must be checked by observations of temperature, moisture of the air, present direction and force of wind, and state of the sky, before any correct opinion can be formed as to what may be expected. In general, whenever the level of the mercury continues steady, settled weather may be expected; but when it is unsteady, a change must be looked for, and perhaps a gale.

A sudden rise of the barometer is very nearly as bad a sign as a sudden fall, because it shows that atmospherical equilibrium is unsteady. In an ordinary gale, the wind often blows hardest when the barometer is just beginning to rise, directly after having been very low.

Besides these rules for the instruments, there is a rule about the way in which the wind changes, which is very important. It is well known to every sailor, and is contained in the following couplet:

When the wind shifts against the sun,
Trust it not, for back it will run.

The wind usually shifts *with the sun*, *i.e.*, from left to right, in the northern hemisphere. A change in this direction is called *veering*.

Thus, an east wind shifts to west through southeast, south, southwest; and a west wind shifts to east through northwest, north, and northeast.

If the wind shifts the opposite way, *viz.*, from west to southwest, south, and southeast, the change is called *backing*, and it seldom occurs unless when the weather is unsettled.

However, slight changes of wind do not follow this rule exactly; for instance, the wind often shifts from southwest to south and back again.

In the southern hemisphere, the motion with the sun is, of course, from right to left, and therefore the above rules will necessarily be reversed.

Admiral Fitzroy proposed the following words for barometer scales:

RISE.	FALL.
For	For
North,	South,
N.W., N., E.	S.E., S., W.
Dry	Wet
or less	or more
wind.	wind.
Except	Except
wet	wet
from	from
North.	North.

462

No reading from a mercurial barometer that is not hanging vertically should ever be relied upon.

THE ANEROID BAROMETER.

In this instrument the atmospheric pressure is measured by its effect in altering the shape of a small hermetically-sealed metallic box, from which nearly all the air has been withdrawn, and which is kept from collapsing by a spring.

When the pressure rises above the amount which was recorded when the instrument was made, the top is forced inwards, and *vice versa*; when the pressure falls below that amount, the top is forced outwards by the spring.

These motions are transferred by a system of levers and springs to a hand moving over a graduated dial.

The instrument is very sensitive, showing minute changes that are concealed by the "pumping" of the quicksilver, even in the best mercurial barometers, when the motion of the ship is violent. Nevertheless, the working of the aneroid should be used only for purposes of comparison and in conjunction with a good mercurial barometer.

NOTE ON THE USE OF THE BAROMETER.

"In all parts of the world, towards the higher latitudes, the quicksilver ranges, or rises and falls, nearly three inches, namely, between about thirty inches and eight-tenths (30.8), and less than twenty-eight inches (28.0) on extraordinary occasions; but the usual range is from about 30.5 inches, to about 29 inches. Near the line, or in equatorial places, the range is but a few tenths, except in storms, when it sometimes falls to 27 inches."

In the northern hemisphere, the effect of the veering of the wind on the barometer is according to the following law:

- With east, S.E., south winds, barometer falls.
- With S.W. winds, barometer ceases to fall and begins to rise.
- With west, N.W., north winds, barometer rises.
- With N.E. winds, barometer ceases to rise and begins to fall.

In the southern hemisphere the law is as follows:

- With east, N.E. north winds, barometer falls.
- With N.W. winds, barometer ceases to fall and begins to rise.
- With west, S.W., south winds, barometer rises.
- With S.E. wind, barometer ceases to rise and begins to fall.

To appreciate correctly the indications of the barometer, we must have, as above stated, at the time of

thermometer, and the thermometer attached to the barometer should be read with every reading of the latter.

The wet bulb thermometer has a piece of linen tied around the bulb, wetted enough to keep it damp by a wick dipping into a cup of water. It will give a lower reading than an ordinary thermometer, in proportion to the dryness of the air and quickness of drying. In very damp weather, *with* or before rain, &c., the dry and wet bulb thermometers will be nearly alike. The drier the weather, the more evaporation can take place, from the moisture surrounding the wet bulb, hence the lower the temperature shown by that bulb under such circumstances, and consequently the *greater difference* between the reading of such an instrument and that of a dry bulb thermometer. A comparison between the two affords, therefore, at all times, a means of ascertaining the relative dryness or moisture of the air. About six degrees difference between the wet and dry bulb readings is considered healthy in a temperate climate.

Pouring water over the wet bulb instead of merely moistening it imparts to the mercury the temperature of the water, which *may* be higher than that of the air.

If a barometer has been about its ordinary height, say near thirty inches at the sea level, and is steady or rising, while the thermometer falls and dampness becomes less, northwesterly, northerly, or northeasterly wind, or less. wind, may be expected.

On the contrary, if a fall takes place with a rising thermometer and increased dampness, wind with rain (or snow) may be expected from the southeastward, southward, or southwestward.

But a *wet* northeasterly wind may cause the barometer to rise, on account of the *direction* of the coming wind alone, thus deceiving persons who, from the rising of the barometer only, expect fine weather.

Indications of approaching changes are shown less by the height of the mercury than by its falling or rising. A rapid rise indicates unsettled weather.

A slow rise with dryness, fair weather.

A rapid and considerable fall is a sign of stormy weather and rain.

Alternate rising and sinking shows very unsettled weather.

The greatest depressions are with gales from the southeast to southwest; the greatest elevations with winds from northwest, northward, or northeast.

But the barometer *may* rise with a *dry* southerly and fall with a wet northerly wind.

Although the mercury falls lowest before high winds, it frequently sinks considerably before heavy rain. The barometer falls, but *not always*, on the approach of thunder

and lightning, or when the atmosphere is highly charged with electricity. Before and during the earlier or middle part of severe and settled weather, the mercury commonly stands high, and is stationary.

The tides are affected by atmospheric pressure, so much that a rise of one inch in the barometer will have a corresponding fall in the tides of nine to sixteen inches, or say one foot for each inch.

"Vessels sometimes enter docks, or even harbors, where they have scarcely a foot of water more than their draught; and as docking, as well as launching large ships, requires a close calculation of height of water, the state of the barometer becomes of additional importance on such occasions."

NOTE.-In south latitudes for north read south, and for south, north in these pages.

CIRCULAR STORMS,

AND THE MEANS OF AVOIDING OR MANOEUVERING IN THEM.

Hurricanes, cyclones or typhoons are progressive, revolving gales, which may be described as great whirlwinds turning around and moving forward at the same time. Their diameter varies from 50 to 1000 miles,* within which limits currents of air move with a velocity of from 80 to 130 miles an hour around a central calm space of low atmospheric pressure; at the same time the whole storm area moves forward on a track, either straight or curved, at the rate of from 1 to 40 miles an hour. This velocity of translation, however, not only varies in different localities, but in storms passing over the same locality and even in one and the same storm during different stages of its existence.

Revolving Motion of the Storm. In each hemisphere the gyration of these storms takes place invariably in one direction, and that direction contrary to the apparent course of the sun. Hence in north latitudes the storms revolve from *right* to *left*, in south latitudes from *left* to *right*.

Forward Motion of the Storm. Within the tropics these storms commence to the eastward, travel for some distance towards the westward, inclining a point or two toward the pole of that hemisphere which they are crossing, curving away from the equator. When they reach the 25th degree of latitude, they generally curve still more until they move to the northeast in the northern

* The storms in the North Atlantic are said to commence with a diameter of from 100 to 150 miles and then to increase to 600 or 1000 miles, a fair average is perhaps 500 miles. In the Arabian sea they probably do not exceed 240 miles. In the Bay of Bengal they are from 300 to 350 miles in diameter. In the South Indian Ocean, from 150 to 600 miles, and in the China Seas from 80 to 350 and possibly as high as 600 miles.

hemisphere and to the southeast in the southern hemisphere. Occasionally they cross the line of the shore and sweep over the land, as in the East Indies and China Sea; more frequently they seem to be repelled by the land.

The Atlantic and Japan storms, for instance, almost always wheel round to the northward and follow the seaboard of North America or Japan.

Another remarkable feature of these storms is their increasing violence in the neighborhood of their centre, and as this is approached (unless on the direct line of its own progressive motion) the more rapid become the changes of the wind.

INDICATIONS OF CIRCULAR STORMS.

The Barometer. The barometer, as an instrument of warning, and also as an approximate measure of the distance from the centre, is of vital importance to the seaman.

First. The barometer generally indicates the approach of the storm by a restless oscillating motion of the mercury, caused by a disturbed condition of the atmosphere in the vicinity of a storm. These oscillations have been observed to vary from a just perceptible motion to 0.02 inch.

Second. The barometer often rises suddenly on the border, just in front of a storm, by reason of the air banking up there, and therefore if the general appearance of the weather indicates the approach of a storm, a rise in the barometer, instead of being a guarantee that none will come, is rather a sign that a severe storm is coming. It would probably not rise much in front of a slowly moving storm.

Third. A very rapid fall of the barometer, after fairly entering the storm disk, may be regarded as evidence of a very violent storm of small diameter, and a gradual fall would indicate the contrary.

Fourth. If a vessel is caught in a cyclone in a dangerous position near the land, the knowledge of her distance from the centre might be all-important, even if that distance could only be determined within fifty miles. To aid navigators in determining the distance of the centre probably within that amount, the following table from Piddington's "Horn-Book" may prove of service:

Average fall of barometer per hour	Distance in miles from centre.
From 0.02 inch to 0.06	From 250 to 150
From 0.06 inch to 0.08	From 150 to 100
From 0.08 inch to 0.12	From 100 to 80
From 0.12 inch to 0.15	From 80 to 50

30

466

The fall of the barometer has been compared in a great number of cases with the above, and the result has generally proved favorable to the accuracy of the table.

Other Indications. The signs of a cyclone's approach do not differ materially from those preceding an ordinary gale. A hard steel-gray or greenish sky, a blood-red or bright yellow sunset, a heavy swell or confused agitation of the sea not accounted for in any other way, and a threatening appearance of the weather ought to be regarded as significant signs of a more than ordinary gale, particularly if accompanied by a restless state of the barometer.

When by any such indications the navigator has reason to suspect the neighborhood of a cyclone, his first care is to devise a plan for avoiding it. If with the cyclone chart found in standard works on storms he can determine the direction of the storm's course, he may succeed in keeping clear of it altogether. But if after failing to effect this he is still caught in the storm, he must then determine as quickly as possible:

- 1st. His position in the storm disk.
- 2d. The course of the storm.

TO FIND THE SHIP'S POSITION IN THE STORM DISK.

This is readily determined on the basis of what are known as Redfield's "Laws of Storms." In accordance with these, the bearing of the centre of the storm is:

In the northern hemisphere eight points to the *right*,

In the southern hemisphere eight points to the *left* of the wind point, the observer facing the wind.

A second law is that:

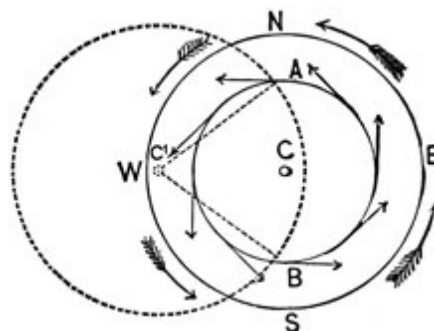
In the *right* semi-circle of the storm the wind changes with the sun, viz., N., E., S., W.

In the *left* semi-circle of the storm the wind changes against the sun, viz., N. W., S., E.


In the first case this N., is contrary to the *rotary motion* of northerly storms; in the second case it is contrary to the rotary motion of southerly storms.

But the reason for the law will be seen, if we draw a circle N., W., S., E., to represent the body of a storm, with a ship anywhere within its influence, as at A. Assuming the ship to be in north latitude, the cyclone will be revolving in the direction shown by the curved arrows, and the wind in each quarter of the storm circle will blow in the direction shown by the straight arrows; for, though it sweeps round the storm's axis, it may, from the small segment occupied by a ship, be represented, as far as she is concerned, as a tangent to the circle.

At A. therefore, she will have the wind from the eastward, and the centre of the storm will be eight points to the right of the wind, or south of her. If it is traveling from east to west, the first shift of wind she will experience will be from the S. E.; for, while moving on its course in the direction C, C¹, it will be changing the bearing of its centre from the ship, which, when at C¹, will be S. W. of her, with the wind from the S.E. So that, though the



storm is revolving, thus:  the wind is shifting in direction

thus:  But if the ship, on the contrary, be in the other semi-circle, say at B, she would have the wind at west, and when the centre reached C¹, at S. W.; consequently, the change being from west to S. W., would *coincide* with the rotary motion of the storm.

Knowing, then, how to find the bearing of the storm's centre, and how to determine which semi-circle a ship is in, we have the elements for giving her position with reference to the storm disk.

In determining in which direction the wind is shifting, it is of the highest importance that the ship should be kept as stationary as possible.

TO DETERMINE THE COURSE OF THE STORM.

If in the right semi-circle, where the wind changes to the right, N., E., S., W., heave to on the *starboard* tack.

If in the left semi-circle, where the wind changes to the left, N., W., S., E., heave to on the *port* tack.

This places the ship in a safe position north or south of the equator, until the course of the storm is determined.

Two bearings of the centre, with an interval of from two to three hours between, will in general be sufficient to determine the course of the storm, provided an accurate account is kept of the ship's way, but if the storm is moving slowly, a longer interval will be necessary. There are but two points in the storm disk of a cyclone where a vessel *hove to* will not experience a change of wind-one is in front of the centre on the line of its axis, and the other in rear of the centre on the same line. For these two cases the barometer must be the guide; in front of the centre it falls, and in rear of the centre it rises.

There are also five points in the storm disk of a cyclone, where a vessel may *run* along with the storm, parallel to its course and at equal speed without having any change of wind, and with a steady barometer.

Northern Hemisphere:

1st. *In front of the centre on a line with its axis:*
Wind on starboard beam.

2d. *Anywhere in the right forward quadrant:*
Wind on starboard side abaft the beam.

3d. *Abreast and to the right of the centre:*
Wind aft.

4th. *Anywhere in the right rear quadrant.*
Wind on port side abaft the beam.

5th. *In rear of the centre in a line with its axis:*
Wind on port beam.

Southern Hemisphere:

1st. *In front of the centre in a line with its axis:*
Wind on port beam.

2d. *Anywhere in the left forward quadrant:*
Wind on port side abaft the beam.

3d. *Abreast and to the left of centre:*
Wind aft.

4th. *Anywhere in the left rear quadrant.*
Wind on starboard side abaft the beam.

5th. *In rear of centre in a line with its axis:*
Wind on starboard beam.

The above manoeuvres are possible if sail can be carried, but only the last three in each hemisphere are advisable, viz., the position abreast of the centre, in the rear quadrant, or in rear of the centre. Running along with the storm in front of the centre, or in the forward quadrant, should never be resorted to; an accident temporarily disabling the vessel would at once place her in great danger of being overtaken by the centre.

TO RUN OUT OF THE STORM.

Northern Hemisphere. (See Storm Card, Plate 117):

Right Semi-circle. Haul by the wind on starboard tack, and carry sail as long as possible; if obliged to heave to, do so on starboard tack.

Left Semi-circle. Bring the wind on starboard quarter. Note the direction of the ship's head, and steer that course. If obliged to heave to, do so on port tack.

On the storm track, in front of centre: Square away and run before it. Note the course and keep it, and trim the yards when the wind draws on the starboard quarter. If, however, obliged to heave to, do so on port tack.

On the storm-track, in rear of centre: Run out with wind on starboard quarter, or heave to on starboard tack.

Storm Card.

NORTHERN HEMISPHERE.

ABBREVIATIONS.

Nd.—northward.	ch.—change.
Ed.—eastward.	h.—heave-to.
Sd.—southward.	Str.—starboard
Wd.—westward.	P.—port.

REMARKS.

The courses here given are for the wind two points on the starboard quarter, but if sea and wind permit, bring the wind broad on the quarter. If in either of these positions there be danger of broaching-to, run before the wind until more moderate, and then bring wind on starboard quarter. A ship heave-to having the wind steady, is on the storm-track. Run before the wind, note the course, and keep it.





Southern Hemisphere. (See Storm Card, Plate 118.)

Right semi-circle: Bring wind on port quarter. Note the course and keep it. If obliged to heave to, do so on *starboard* tack.

Left semi-circle: Haul by the wind on *port tack*. Carry sail as long as possible, and if obliged to heave to, do so on *port tack*.

On the storm-track, *in front of centre*: Run before it. Note the course and keep it, and trim the yards as the wind gradually hauls on the port quarter. If obliged to heave to, do so on *starboard* tack.

On the storm-track, *in rear of centre*: Run out with the wind on *port quarter*, or heave to on *port tack*.

A rise of the barometer, improvement of the weather, and a gradual abatement of the force of the wind, will result from the above manoeuvres; and the ship should in each case be kept on her course until, by these signs, it is made evident that she is out of danger.

All the above manoeuvres depend of course on sea-room, and the ability to carry sail. If sail cannot be carried, or land interferes, the ship must be hove to on the *starboard* tack in the *Right* semi-circle, and on the *port* tack in *Left* semi-circle, and never otherwise. The old popular idea of heaving to on the starboard tack in the northern hemisphere, and on the port tack in the southern hemisphere, under all circumstances, is dangerous practice, and may lead to serious consequences.

The results of the manoeuvres herein recommended should, as before stated, be a rising barometer and improvement in the weather. If, however, the barometer continues to fall, or remains stationary, and the weather becomes either worse or remains the same, it is evidence that the indraft is very great, and in either case the ship should be hauled up as near the wind as possible under the circumstances of wind and sea, and so kept until a decided rise of the mercury and improvement in the weather take place.

Thus the barometer is always a measure of safety, even when the rules laid down for avoiding the centre fail to carry a vessel out of the dangerous part of the storm.

In a very extreme case of indraft, where it is found impracticable to distance the centre by sailing, the vessel should be prepared for a heavy blow, and hove to on the proper tack, until either the centre has passed or an opportunity occurs (by a change in the wind) for avoiding it.

It sometimes occurs, although the cases are very rare, that a cyclone takes a sudden turn, and recurves on its track so much as to render a vessel liable to run into it a second time.

Storm Seasons. The period of the year during which cyclones are most frequent may, in a general way,

470

be considered. In north latitude, from June to November; August and September being the worst months. In south latitude, from September to May; February and March being the worst months. In other words, the cyclone season appears to correspond to the time when the sun is nearing the equator, on the return from the highest declination in either hemisphere.

471

IN A GALE-SCUDDING-LYING TO-RUDDER GONE-CUTTING AWAY MASTS.

LET the wind be supposed to be increasing gradually, the topsails to be single reefed, and the topgallant sails furled.

To Take In the Jib, and Set the Fore Topmast Staysail. *Man the jib downhaul! Topmast staysail halliards! Clear away the downhaul! HOIST AWAY! Clear away the halliards! HAUL DOWN!*

The jib sheet should be eased off as the sail comes down. In setting the staysail, first haul aft the sheet, and then ease it off as the sail goes up. To take in and stow a jib when blowing hard, it is always better to run the ship off if possible.

As the wind freshens, take a second reef in the topsails, and a single reef in the courses.

The wind increasing, to take a third reef in the topsails. proceed as with the second reef, observing not to brace the topsail or lower yards too sharp up. Get preventer-braces and parrels on. See Chapter XXIII.

To Haul up and Furl the Mainsail.

Man the main clew-garnets and buntlines! the weather clew-garnet, both buntlines and leechlines are manned. Before starting anything, haul taut the lee main lift, and ease off a fathom or two of the main sheet. *Ease away the main tack and bowline!* HAUL UP TO WINDWARD!

The lee buntline is hauled up as far as it will go.

When the weather clew is up, *Ease away the main sheet!* HAUL UP TO LEEWARD! Run up all the gear, send the men aloft and furl the sail, keeping the ship as near the wind as possible, and not sending the men on the yard until it is secured and sail hauled close up.*

To Send Down Royal Yards. The officer of the deck commands, *Get the royal yards ready for coming down!* At this order, the royal yardmen lay aloft and unbend royal gear, stop the yard rope out to leeward, bend the tripping-line to the snorter to windward, and send it down to windward and abaft everything; the topmen on deck

* If the main yard is weak, get a jumper on the weather yard-arm, before starting the main tack.

take off the royal halliards and lead along the yard rope. *Man the yard ropes and tripping-lines! Tend the braces!* when manned, *Stand by-SWAY!* The yard is swayed up and down, and yard-arms unriggered as it comes down; the men in the top pulling up on the lee lift and letting go the weather one when the order is given to sway.

The yards being on deck, are secured in the gangways or on the booms.

Sending Down Topgallant Yards. *Get the topgallant, yards ready for coming down!*

The topgallant yardmen lay aloft, unreeve topgallant studding-sail halliards, unbend topgallant gear, &c., &c., as with the royal yards. Send down the yards to windward and abaft.

Leave the short yard ropes aloft, and send down the yards with the long ones.

Next close reef the topsails, as described in the previous chapter. When reefed, sway the yards clear of the cap and trim them.

NOTE. In hauling out the reef-tackles, preparatory to close-reefing, haul up on the clewlines when easing off the sheets, particularly in cold weather, when they may not render readily; otherwise, the leech may be torn out of the sail.

When it becomes necessary to take the second reef in the foresail, haul it up as described in taking in the mainsail, and reef as before. The sail being reefed, set it as already explained.

To set fore-storm staysail, and haul down fore topmast staysail, proceed as in taking in jib and setting fore topmast staysail.

The mizzen topsail will be taken in probably when the close reef is taken in the fore and main.

The main trysail may be set next, reefed if necessary. If additional after-sail is required, the spanker may be reefed and set before taking in the mizzen topsail.

To take in the close-reefed fore topsail, proceed as described in Chapter XXIII.

Finally, haul up and furl the fore sail.

The ship is now "lying to" under close-reefed main topsail, fore storm staysail, and probably single reefed trysail.

For gear manned and precautions observed in taking in sail, blowy weather, see Chapter XXIII.

PREPARATIONS FOR A GALE.

Get up and hook pendant-tackles, and preventer braces (if not already on); yards pointed to the wind, and secured and hoisted clear of the caps; anchors, boats, and guns, well secured; life-lines fore-and-aft all the decks; spare spars

473

and yards on deck well lashed, as also everything movable on deck and below. Have hatches ready for battening down; spare axes at hand; pumps clear; storm staysails and gear overhauled and ready; relieving tackles ready for hooking; spare tiller at hand; also compasses.

If expecting a hurricane, get the flying-jib boom in; send down top-gallant masts; studding sails out of tops; all shot below out of racks; pass a hawser round the laniards of lower rigging; cook provisions in advance; furl all square sails; set the fore storm-staysail and have the others ready; marl the sails down to the yards with the studding-sail gear, in addition to the gaskets.

NOTE.-It is recommended to send down top-gallant masts in a heavy gale, when the vessel has much top-hammer, as it eases her considerably. When sending them down at sea, under *whole topsails*, it is better to lower the topsail yards at once, and send the masts down forward, than to attempt sending them down abaft. In the case of sending them down with the close-reefed main topsail set, fore and mizzen furled, send the main down *abaft* the topsail yard.

TO SCUD.

In a preceding paragraph, an arrangement of sail has been given for lying to in a gale, but should the wind be favorable, and the sea not running too high, as it will not unless the gale has been of long continuance, a vessel may *scud* before it, under such sail as the force of the wind will allow. In sailing with the wind aft, it is greatly disarmed of its force, and a vessel may carry safely some sail, when, if on the wind, she would be reduced to bare poles.

The best sails for scudding (or *running*) under, are, a close-reefed main topsail, and single or double-reefed foresail; and a gale is rarely of such violence that this sail cannot be carried safely. The former, by its height, will not be becalmed by the waves, while the latter may be necessary, in case of being brought by the lee, to pay her off to her course. The fore topmast staysail should always be set in scudding, or the fore storm staysail sheets hauled flat aft.

Vessels sometimes steer wildly in scudding, in consequence of being out of trim, of their bad qualities, or the force of the sea on either quarter, in which cases, or by the negligence of the helmsman, she may, in

yawing, bring her sails aback. She is then "*brought by the lee*," or "*has broached to*." The proper manner of recovering her is as follows:

Brought by the Lee. Suppose, in scudding, with the wind a little on the port quarter, under the sail as above, you are brought by the lee, and have everything aback.

474

The wind is now on the starboard beam, *Put the helm hard to starboard!* until headway ceases, when shift it. Man the port braces fore and aft. **RISE FORE TACK AND SHEET!** *Clear away the head bo'lines!* **BRACE FULL THE HEAD YARDS!** and shiver the after ones. Attend the lifts, as in former evolutions. She will pay off under this arrangement, the helm itself partly effecting it before she loses headway.

When before the wind, right the helm and trim the yards for the course. Haul taut the lifts, &c.

Broaching to. In case of having *broached to*, and brought the wind on, or forward of, the port beam, meet her with the helm and lee braces, by putting the helm hard a-port, and hauling in the starboard head braces.

REMARKS ON SCUDDING.

In scudding, the tiller ropes are constantly doing double duty; and though the relieving tackles are hooked, you cannot steer the ship with that nicety that you can with the wheel. Should the tiller ropes unfortunately be carried away, the risk of broaching the ship to is then considerably augmented.

Sometimes, unavoidably, in scudding, you are obliged to carry your fore topsail and foresail; when that happens, it may arise from some accident received to the spars or rigging on the main mast, in which case it is generally considered advisable by good seamen to make the fore topsail and foresail rather rising sails by easing off the sheets until they have that tendency. Of course, when all things are right on the mainmast, the main topsail and foresail are the best sails for scudding under, while the ship will carry them. It is generally considered best that the foresail should rather raise the bow than have the contrary effect, more particularly in sharp vessels.

There is a point beyond which no vessel can scud without the greatest possible danger. Of course much will depend on the size and height of the vessel out of the water, but there is scarcely ever heard a dissenting voice as to flush vessels being by far the most dangerous while scudding in heavy weather. You should bring your ship to the wind while it can be effected without the greatest risk to ship and lives. If night is coming on, and the weather has every appearance of an increasing gale, with a falling barometer, and circumstances will admit, it would be advisable to lay the ship by the wind; and as every gale may be supposed to partake of the nature of a cyclone, taking care to select, if optional, that tack which is indicated by the conclusions of the previous chapter.

475

TO BRING BY THE WIND AFTER SCUDDING.

We will, for example, bring to on the port tack.

Have the storm staysails ready, sheets hooked and moused, secure everything about the decks and below. Send everybody on deck. Put on and bat ten down the hatches. Man the fore clew-garnets and, buntlines, starboard fore and main and port cross-jack braces. Watch for a smooth time. Haul up the foresail, put the helm to starboard, brace up the after yards, and haul out the storm mizzen and hoist the mizzen staysail or set the main trysail. As she comes to set the fore trysail and meet her by the helm, the head braces, and by hoisting the fore storm staysail. Then haul taut the lifts. It may be necessary to furl the main topsail, and she may lie to better without the fore storm staysail. After she has recovered from the first shock of the sea, and has lost her headway, she will, with the helm a-lee, and under a proper arrangement of the sails, lie to, coming up and falling off two or three points, and drifting bodily to leeward.

When a vessel labors much in a seaway, either lying to or standing on her course, the sails should never be hoisted up, or the braces hauled, as taut as in a smooth sea; for the play of the masts will either carry

away the braces and sheets or spring the yards. And if the pitching is hard and quick, you should see that the helm is eased, allowing it to go to leeward, so that she may obey freely the sea, the shock of which will be less violent against the rudder.

After the gale abates, sail *should not be made* upon the vessel *too rapidly*, particularly if her course will bring the sea ahead or forward of the beam. You should be content with giving her headway Until the sea also abates; for, by forcing her through a head sea, you strain every mast and yard, and injure the rigging.

Preventer braces, shrouds, and backstays, used in heavy weather, as a relief to the standing ones, are of great importance to the mizzen topmast. The standing part of the main topsail brace leads from the mizzen topmast nearly at right angles, while the angle formed by the backstay is too small to afford a sufficient support.

RUDDER, WHEEL-ROPES, RELIEVING-TACKLES.

The rudder, wheel-ropes, and relieving-tackles, should occupy the particular attention of the first lieutenant and navigator. The former, with its tiller, are permanent fixtures, so arranged, and of such durable materials, that they should withstand the severest shocks. Wheel-ropes are liable to chafes, and should be occasionally examined by

476

the navigator. Those of raw hide, now in common use, are found to be fairly serviceable and durable. They should be occasionally oiled and be protected from injury.

Relieving-tackles should be kept fitted, and constantly at hand, and, in a gale of wind, with a heavy sea, when the parting of a wheel-rope might endanger the vessel, should be kept hooked, and hands stationed by them under the direction of an officer.

RUDDER GONE.

If the rudder head only has been carried away, the rudder remaining shipped, it can be used for steering by means of the rudder chains. In view of this possibility, the rudder chains should be stopped up so that their ends are accessible in case of need.

The possibility of having to use rudder chains for steering purposes has sometimes been overlooked; the chains themselves are difficult to get at, the fastenings on the rudder have not been sufficiently far down, and only common bolts have been inserted instead of a stout metal strap, which should clasp the after part of the rudder.

The rudder chains should have pendants spliced into them, leading up over the taffrail where they can be got at.

In using them to steer the ship, the rudder head being wrenched off, lower the cross-jack yard on the rail, lash it there, and lead pendants from the rudder chains through blocks at the yard-arms, hooking tackles into the pendants.

Cases have occurred, in which rudders have been unshipped or otherwise injured, so as to be of no further use, when it has been necessary to resort to some expedient to manage the vessel.

Vessels can always be better managed when by the wind, than in any other situation. They will sometimes steer themselves for hours, having their yards so trimmed and their sails so regulated as to keep by the wind. Care must be taken that the vessel holds a good wind, and at the same time does not *gripe*. By slacking, on the one hand, a few feet of the head sheets, and on the other of the spanker and main sheet, an equilibrium will be established between the head and after sails.

The moment you lose your rudder, bring her up by the after sails, bracing the yards, and meet her, as she comes to, with the head sails. Then, by reducing the sails forward or aft, and bracing the yards, you may steer her, until you can resort to better means, as follows:

Rouse up from below the heaviest hawser and a towline; middle and clove-hitch the towline, and veer the end of the

477

hawser over the taffrail, through this hitch; after veering out about fifty fathoms of hawser, jamb the hitch and rack it well, securing it so that it cannot slip. Then veer out the hawser until the hitch takes the water. Lash the hawser on the centre of the taffrail, and a spare spar under it and across the stern, with a block well secured at each end, through which reeve the ends of the towline, one on each quarter. Reeve them again through blocks at the ports, abreast of the capstan, by which you may steer your ship until you can construct a temporary rudder.

By rousing in the towline on either quarter, the force of the sea on the hawser, drawn over on that quarter, moves her stern the opposite way.

STEERING WITH TWO DRAGS.

If the hawser and towline do not answer the purpose, the following temporary steering gear has been tried, with success:

Make two cone-shaped canvas bags, with the seams well roped. Fit each with a tripping-line from the pointed end, and a good towline secured to a crow'sfoot on the large end. The tripping-lines are secured inboard, so as to tow the drags, pointed end first, when the wheel is amidships; the towlines lead through blocks on the ends of the cross-jack yard (which is lowered across the rail), and thence through suitable leads to the wheel. When the *wheel* is turned, say to starboard, it brings a strain on the starboard towline, canting the starboard drag so that it tows mouth foremost, and bringing a strain on the starboard quarter, which turns the ship's head to starboard. When the wheel is righted, the starboard towline being slacked off, the tripping-line takes the strain of the drag and cants it, pointed end foremost again, throwing it out of action.

Similarly turning the *wheel* to port, brings the port quarter drag mouth foremost, and throws the ship's head to port.

The drags should tow with a long drift.

TEMPORARY RUDDERS.

Men-of-war are generally supplied with spare pieces to construct a temporary rudder.

In the absence of these, a piece of a spare topmast may be used for the main piece, building out from its heel in proper form, and adding enough pig-iron ballast (also at the heel) to sink it. An eye-bolt is screwed into the upper end of this temporary rudder, and it is got into place in the same manner as an ordinary one, except that the hawser guys at the heel remain permanent.

478

To supply the place of pintles and gudgeons, the head of the temporary rudder passes through the round hole of the spare lower cap, the wood around the square hole is cut away so that it will fit the stern-post, where it is secured after the rudder has been gotten over and placed.

The vessel is steered by guys attached to the rudder outside, leading through blocks on the cross-jack yard lowered to the rail as before.

In arranging the gear of a temporary rudder in a screw ship, it may be necessary to take the guys through the screw aperture under the after bearing, as at G, Fig. 506, and thence up on the opposite side. Or the guys may require leaders in line with the keel, as in Fig. 507.

In case it should be impossible to ship the head of the temporary rudder through the rudder hole, the plan shown in Fig. 506 might be adopted.

Use a spare topmast for the rudder stock, heel down, and weighted if need be. The rudder frame formed by a stout spar (capstan bar) secured in the fid-hole, so as to project aft, and other suitable pieces of timber securely lashed together. Take out the halliard sheave, and through the sheave hole thrust two iron mast-fishes, or a suitable iron bar, lashing to this a thwartship spar to serve as a yoke. Fig. 506 *a*.

A pair of sheers are rigged over the taffrail to hoist out, the rudder and maintain it in position, guys led as shown in the figure, or as in the dotted line *g*.

A back lashing *B* through the stern hawse-pipes counteracts the tendency to rise, and a tackle *T* from the upper part of the rudder head to the mizzen-mast is used to keep the lower part of the rudder clear of the stern-post when the vessel is making but little headway. A spare gaff, with the jaws pointed over the taffrail and securely lashed, is used to counteract the inboard thrust of the rudder.

With jury-rudders of this description, vessels have been handled in all kinds of weather, though difficulty is experienced in heaving to with them, unless canted well clear of the stern by some such arrangement as the tackle *I*.

Owing to its disadvantages when the ship has but little headway, the effect of lee helm in lying to might be obtained by keeping the screw (two-bladed) athwartships, but this use of the screw would depend on its form, and also the tack the ship was on.

A very good form of temporary rudder, adapted for vessels with small rudder ports, is shown in Fig. 507.

The rudder proper is a rectangle, which may be formed of a gangway grating covered with canvas, or which can be built up to suitable size with plank. It is fitted with two yard-bands, *Y Y*, as travellers, to hold it to the temporary rudder-post *P*.

479

The rudder has four spans, one at the top, one at the bottom, and one on each of the after sides.

Having cut a suitable spar (topmast studding-sail boom) to a proper length, fit a block and heel guys at the lower end. The heel guys lead through bull's eyes on each side of a length of stream chain, the chain passing under the keel. On the same chain may be leaders, *K*, for the wheel-ropes. In the figure the lizards for the heel guys are shown, fitted, separately and crossing under the keel.

To get the bight of a chain at the required place, drop it, overboard from forward, under the bowsprit, with the bull's eyes lashed on and marrying lines rove through them, then bring the ends of the chain aft outside of all.

Through the block at the heel of the rudder-post is rove the downhaul for the rudder, which secures to the lower span and comes inboard through the rudder port. The head of the rudder-post is securely lashed inboard. A line from over the taffrail secures to the span on the top of the rudder, and the wheel-ropes lead through the fair leaders *K* to the sheaves in the cross-jack yard, that spar being lowered on the rail.

In a light breeze the rudder must be hauled up nearly to the level of the water to have its greatest effect; the greater the speed of the ship the more the rudder should be immersed.

With a jury-rudder of this kind, the Austrian barque *Norma* was handled with ease during a thirty-day passage from Candia to Trieste, beating up to her anchorage in the latter port.

USING A DRAG IN A GALE.

The method of steering by a hawser or cable may be resorted to in other emergencies besides that of losing a rudder. It is related by an officer of great experience, that having being caught in a hurricane, in the Florida channel, in one of our small vessels, it was found that she steered so wildly as to be in constant danger of broaching to. It soon became evident if something was not done the brig would certainly be lost.

The largest hawser on board was there fore got up and paid out over the stern for a considerable distance in her wake. Its effect exceeded the most sanguine expectations. It acted as a drag, seeming to break the force of the sea, and steadying the little vessel so as to render broaching to impossible. The severity of the gale may be understood when it is known that a Spanish frigate foundered at her anchors in the Havana, and three merchantmen. went down in sight of the brig.

480

LYING TO

UNDER CLOSE-REEFED MAIN TOPSAIL, REEFED MAIN TRYSAIL, AND FORE STORM STAYSAIL, YOU ARE KNOCKED DOWN.

Hard up! LET GO MAIN TRYSAIL SHEET AND PEAK OUT-HAUL! *Main topsail clewlines! Let go the sheets!* CLEW UP! If you have time to clear away the fore topmast staysail, or foresail, hoist away the first and haul aboard the fore tack, but if not, and the ship does not go off, *Man the weather fore rigging!* Send as many men aloft as can stand there, and she will probably fall off.

A SHIP ON HER BEAM ENDS.

If thrown on your beam ends at any time, under any circumstances, let fly everything. If she does not right, cut away the masts (which in this case will be accomplished by cutting the laniards of the weather rigging). Cut the lashings of the spare spars and boats if possible, as well as of everything else on deck which will float.

If on soundings, cutting away an anchor (chain bent) will bring her head to wind, and perhaps right her.

TO RIDE OUT A GALE

UNDER THE LEE OF A SPANNED SPAR.

Liardet says: "It is astonishing that so few attempts have yet been made by seamen generally to save their vessels by riding out gales under the lee of spars. We continually hear of boats being saved by these means; and if a ship get on her beam ends, stop-waters are advised to be veered from her quarter to get her before the wind by the best professional writers, and seamen generally. But let a vessel have her sails blown away, be partially dismasted, or even wholly so, rolling about in the trough of the sea; still you seldom hear of the same resources being tried to ride the ship by. The stream cable, or one of the strongest hawsers, bent on to the wreck of the masts, &c., previous to cutting it away, would make a capital sea-anchor; however, should you not be able to make a hawser fast to the wreck, it takes very little to keep a ship head to wind; a few spars from the booms, a quarter, or stern boat, might be so slung, as when sunk to ride the ship well; even a small anchor and cable veered to about fifty or sixty fathoms, would be found most useful; whatever you put over the

Fig.506a

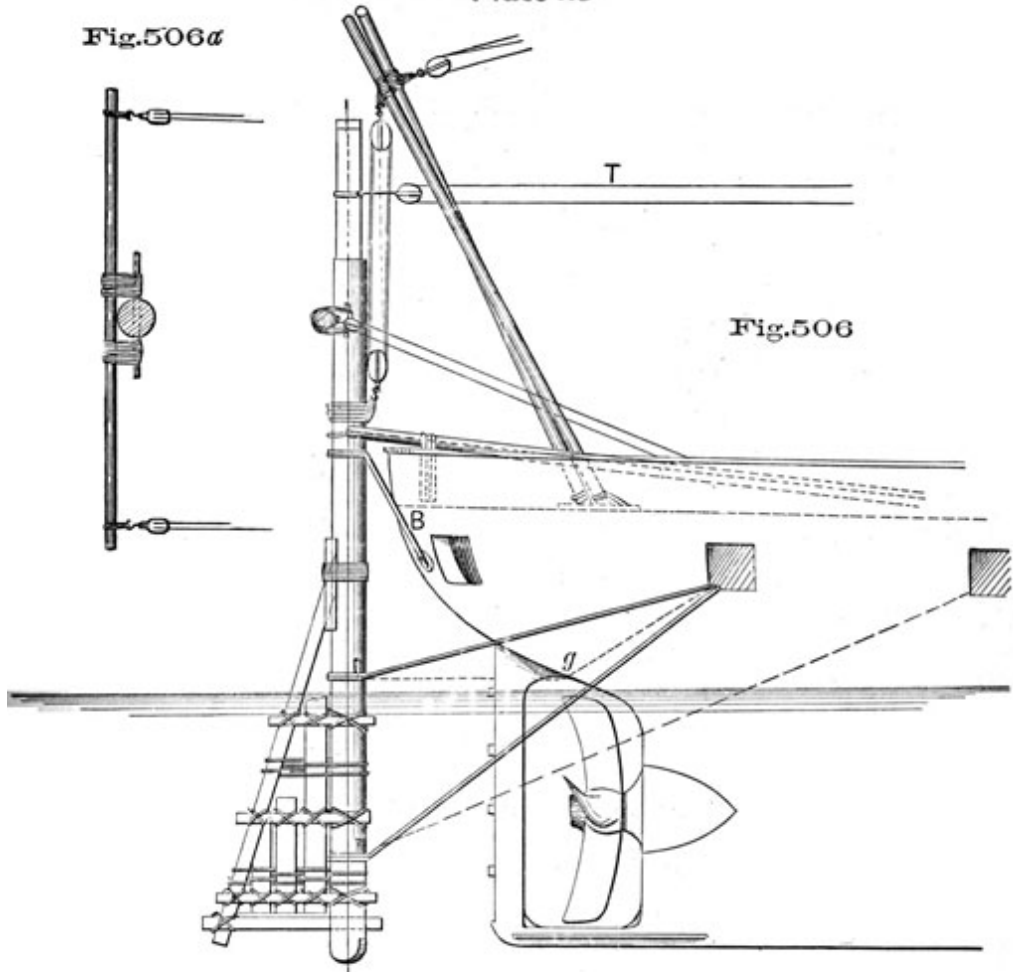
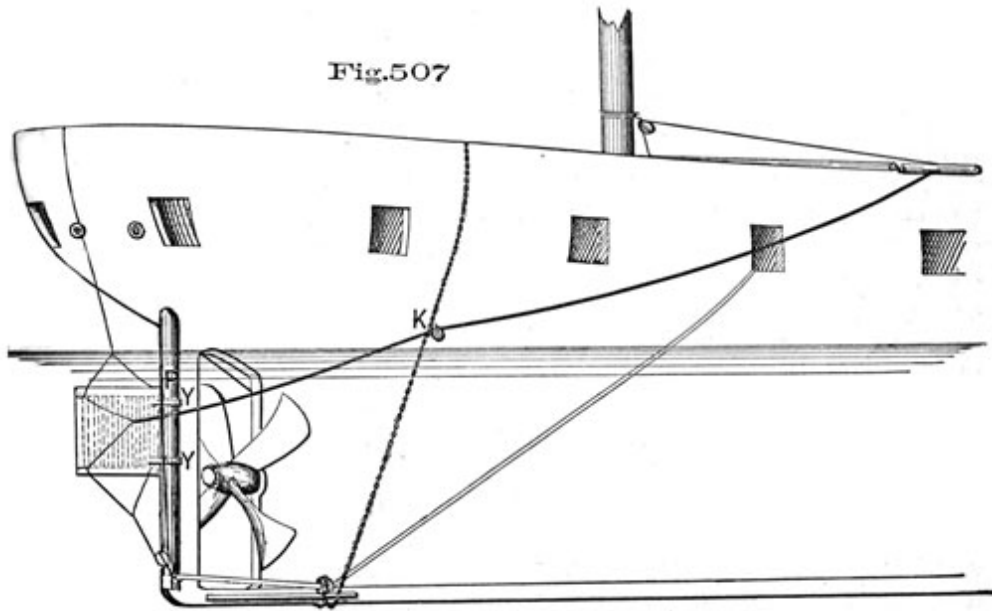


Fig.506

Fig.507



bows will tend to make the sea strike the ship in a better position for her safety. We are strongly of opinion that if more attention were paid to having a stop-water of some kind from the head of the ship to make her ride head to wind, when from the loss of masts, rudder, sail, or derangement of engine, you cannot keep the ship out of the trough of the sea, it would tend to lessen the number of shipwrecks."

For description of a sea anchor, see ANCHORS.

CUTTING AWAY MASTS.

First pass a hawser outside the laniards of the rigging on the side you intend the masts to fall over. If the port side, cut away the mast on the starboard side, as high up as you can, for the stumps will be of service in securing your jury-masts; and, when you have weakened it sufficiently, cut away all but a pair of laniards on each side, guided by circumstances; then get out of the way, and cut away the remaining starboard laniards, keeping fast the stays till the mast has fallen, when you free them immediately. And finally, cut the port laniards adrift, which you will be able to get at by their being kept up by the hawser.

If all three masts are to go, commence with the mizzen mast and work forward; although, when at anchor, it is generally not advisable to cut the mizzen mast away, as it is of great service in keeping the ship steady, head to wind. This supposes that you intend to try to ride out a gale. If you are cutting away expecting to go on shore, the foremast may be spared if there is any chance of saving the crew by running for any particular spot, otherwise cut it away, and *hold on* to the last. *Never* slip your cables and run for the shore in the hope of making a *lee* by laying the ship in a slanting direction; if the anchors drag she may as well go ashore stern foremost as in any other way.

31

 [Previous Part](#)  [Seamanship](#)
[Home Page](#)  [Next Part](#)

Copyright (C) 2006 [Historic Naval Ships Association](#)

All Rights Reserved

[Legal Notices and Privacy Policy](#)

Version 1.00, 24 Apr 06

PARTING RIGGING

When standing or running rigging carries away, prompt action must be taken to prevent further mischief.

In choosing the remedy, select that which is most likely to save endangered spars, even at the risk of lost or split canvas.

Carrying away weather braces will generally occur at the first burst of a squall, on a wind, nearly all the reefs out and, consequently, no preventer braces aloft. The yard or parrel will be the next thing to go, for the yard flies fore-and-aft at once. Left in that position it will either carry away in the slings or part the parrel and endanger the lee rigging and fore-and-aft stay.

Luff then, first of all, to check the forward movement of the yard; next ease the lee topsail sheet; haul up the course to admit of bracing aback. Then, with the remaining weather brace and lee top bowline, back the topsail and clew down to take the strain off the lee rigging, or lower stay in the case of a lower yard.

Having eased the lee topsail sheet, and hauled up the course, the ship may bear up to repair damages if preferred. But do not bear up before this, for, as the wind came abeam, it would act with still greater force on the sails and consequently make it still more dangerous for the spars.

In substituting new running rigging for old, when the run of the lead is not lost, the ends are spliced or married together, and as one is unrove the other enters its place, otherwise men must be sent aloft to reeve it.

BY THE WIND, WEATHER MAIN BRACE PARTS.

Luff! EASE OFF MAIN SHEET AND LEE MAIN TOPSAIL SHEET! *Weather main clew-garnet!* *Let go the tack,* HAUL UP! *Weather topsail brace, topsail clewlines and buntlines!* *Clear away the main top bowline!* *settle away the topsail halliards,* BRACE ABACK! HAUL OUT THE REEF TACKLES, HAUL UP THE BUNTLINES! HAUL FORWARD THE LEE MAIN TOP BO'LINE! Easing away the lee main brace, and hauling up the lee main clew-garnet. This, by throwing the main

topsail aback, would steady the main yard sufficiently to allow hands to lay out with whips for the preventer braces. If the brace has not unrove through the block on the yard, a hand may secure the end to its own part, so that it may be hauled taut on deck.

Should it be blowing too hard to risk backing the main topsail, take in mainsail, clew down main topsail, and haul up the weather clew. Haul the lee reef tackle well taut, and lee main top bowline.

When a brace parts, the yard is first in danger and then the mast; therefore it is necessary to relieve the yard of the sails immediately.

If this accident occurs forward, *Mind your weather helm!* and after reducing sail, leave the fore yard sharp up to steady it.

BY THE WIND, WEATHER MAIN TOPSAIL BRACE PARTS.

Luff! *Check the lee topsail sheet!* *Weather main brace!* *Main clew-garnets and buntlines!* UP MAINSAIL! BRACE ABACK! *Settle away the topsail halliards!* CLEW DOWN! HAUL OUT THE REEF TACKLES, HAUL UP THE BUNTLINES! Square the main yard, and haul taut the lee main-top bowline. The ship is now "hove to," with the main topsail to the mast.

If not possible to get the topsail aback, clew down and haul up the weather clewline.

With the wind quartering, if the weather main-topsail brace goes, *Hard up!* brace in, up mainsail (lee clew), and clew down as before, easing off lee main-topsail sheet as necessary.

WEATHER REEF TACKLE CARRIED AWAY.

This occurs generally while reefing, in consequence of undue strain produced by want of skill in not placing the yard so that the wind will nearly be thrown out of the sail. The men should be ordered in off the yard instantly; the weather clewline, and as much as can be got of the buntlines hauled up, and enough of the sheet clewed up to admit of bracing the weather arm aback or nearly so; the men may then venture out, and pass a sea-gasket working from the arm inward, until the reef-tringle is reached, when the tackle can be rove afresh. Starting gear with men on the yards is one of those fearful blunders which always inspire topmen with such distrust of the officer who commits them, that they never work well aloft in his watch on deck.

484

WEATHER TOPSAIL SHEET AND CLEWLINE CARRIED AWAY.

When this happens on a wind, the clew flies forward and may be steadied by the bowline. Relieve the yard by checking a couple of fathoms of the lee sheet. The lee clew, buntlines, and reef-tackles must then be hauled up, the yard lowered and squared, the bowline being eased away as the sail comes aback; when so it will lie quiet, and the bowline may be sent with a hauling line from the foretop into the main, rove before the sail through a leading block on the topmast, and the leech thus hauled in along the yard, so that the sail may be handed if needful, and new gear rove; an attempt to "hand the leech in" before lowering, clewing up and squaring, would not only be useless but dangerous.

If the course is not set, check lee sheet as above, round in weather lower and topsail braces, lower and throw the sail aback, easing away the bowline.

LEE TOPSAIL SHEET CARRIED AWAY.

A not unfrequent occurrence when the course is taken in, in a fresh breeze, without hauling taut the lee lower lift.

Haul in the weather brace, settle the halliards, clew down and get the sail aback. When on the cap, haul up the weather clewline, then the lee one.

FORE OR MAIN TACK GONE.

Ease off handsomely the sheet, man the weather gear and lee buntlines; up the weather clew as soon as possible, then the lee one. Do not luff until the gear is well manned, as the spar is not in danger, and it is quite possible to get the sail under control with the means described, while avoiding the risk of splitting it.

MAIN TACK AND CLEW-GARNET GONE.

Check main sheet to ease the yard. The danger of the sail being split will depend much on the position of the mainstay. In many ships it would bring the tack up, so that it could be steadied by the weather sheet, and a new tack rove; if not, the topsail would have to be clewed up, and then the course, the main yard squared, and the weather sheet gathered in at the same time; or, circumstances permitting, bear up and haul weather, sheet aft.

485

FORE OR MAIN SHEET GONE.

Keep away until the wind is abaft the beam, steadying the clew with the lee tack. Haul up the sail when free, and reeve off a new sheet.

TOPSAIL BRACE AND PARREL CARRIED AWAY.

In a strong breeze, where the yard is nipped by the lee rigging so that it cannot be got down by the clewlines, send an anchor strap aloft, pass it around both tyees and the top mast, hook the upper block of the top burton into both bights of the strap, lower block and fall sent on deck abaft the top and taken well aft. Haul down on the clewlines and burton, easing away the halliards until the yard is on the cap; clap on the new parrel; lash the yard by the quarters to the topmast rigging, and then repair the braces.

When this accident occurs under low sail, the yard would fly so far forward as to suggest considerable

danger to it and the mast from the force with which the yard would fly aft, if the sail were thrown aback by squaring the main yard. This latter mode is, however, recommended by some of the best seamen, who, having tried it successfully, are best able to judge of its merits.

If the wind is aft, clew up, hoist the yard close up to the gin-blocks and haul the lifts taut. This will keep it steady until the strap is passed round the ties.

TOPGALLANT BRACE AND PARREL GONE.

Luff, let go the lee topgallant sheet to spill the sail, brace by the lower and topsail yard.

When the topgallant sail catches aback, haul home the lee sheet again to steady the sail, then let go the halliards and haul down on both clewlines. When the yard is down, secure the slings to the mast and clew up. If the yard is unsteady, haul taut the lee brace to bind the yard against the lee rigging. Brace up the lower and topsail yard, and repair the damage to the brace and parrel.

BOBSTAYS CARRIED AWAY.

In 1881 the U.S.S. Constitution carried away the iron straps of her bobstay hearts in a gale off the Capes of the Chesapeake. The fore topgallant mast was sent on deck, pendant tackles hooked from the foremast to bolts in the deck well forward, and top burtons from the fore and

486

main topmast heads set up for fore and aft support. It was deemed unsafe to strike the fore topmast on account of the heavy sea and motion of the vessel; but the amount of sail forward was reduced as much as possible (fore storm staysail and fore trysail).

A short length of stream chain was taken well out on the bowsprit and several turns taken with it, with stout cleats abaft to prevent slipping. The ends of this chain (crossed) were shackled into a large link, hung under the bowsprit, thus forming a strap. The link also received ends of the stream chain passed out through the sheet hawse pipes. The inboard ends of the chains were hove taut with deck tackles on the gundeck.

Double straps of wire rope were fitted for the bobstay hearts, long enough to go around and lash on the upper side of the bowsprit, and were cleated on the sides and top of the same. With these the bobstays were then set up. Wire rope was used for the straps, as it fitted in the scores of the hearts without altering them.

When temporary staying from sheet hawse holes would fail to give efficient support, it has been proposed to use a hawser from the bowsprit cap to a chain passed under the keel, setting up the hawser inboard. Having taken all unnecessary strain from the bowsprit, get up as much of the stream chain as may be required to reach under the ship from a port abaft the fore rigging to the corresponding one on the opposite side. Pass one end of the chain out under the bowsprit clear of all. To the middle of the chain secure one end of a hawser rove through a viol block at the bowsprit cap, the hauling end of the hawser being inboard. When ready, ease the bight of chain down under the bows and set up the ends through the proper ports, the bight being under the keel. Then clap a tackle on the hawser and set it up as a temporary jumper until the bobstays are repaired.

JIB STAY CARRIED AWAY.

The jib would probably split. If not, check the sheet enough to spill the sail; bear up, and when the sail is becalmed haul it in, hoisting the fore topmast staysail.

Replace the jib stay temporarily by the top burton, which should in all cases be long enough to form a spring stay in case of accident.

TOPMAST STAY CARRIED AWAY.

Keep the ship away, shorten sail, overhaul down, hook and haul taut the top burton, and replace the stay with a hawser.

JIB SHEET CARRIED AWAY.

Steady the sail with the weather sheet. *Mind your weather helm!* haul down the jib; ease off the spanker sheet, and clear away and hoist the fore topmast staysail.

TILLER-ROPE CARRIED AWAY.

When this occurs, it may be assumed to be blowing fresh. The first thing to be done, therefore, is to steady the rudder, which, in a seaway, would fly from side to side with great violence. The quickest way of doing so will be by means of the remaining rope; and, as the chances are that the weather wheel-rope will be the one to go, jamb the helm down, shorten sail, and heave to with the head yards abox, if you do not want to come round. Otherwise, if there is a ship close astern of you, for instance, haul the mainsail up, and square the main yard in stays. Should the lee rope go, put the helm up, heave to on the other tack, and shorten sail as soon as possible. If unsafe, from the position of the ship, to do either, man the head sheets and cross-jack braces, and steer the ship by the sails. In moderate weather, the relieving-tackles will probably be hooked before it will be necessary to touch anything. In all cases, send hands down to hook and work them, and reeve new wheel-ropes.

The senior class of midshipmen on board the practice ships are recommended to prepare themselves for working ship without the assistance of the helm.

JIB DOWNHAUL CARRIED AWAY.

This would probably occur in taking in the jib to a squall. Check the jib-sheet to relieve the stay, hoist the sail again and steady the sheet enough to keep the sail from flapping.

Send the downhaul aloft by a hauling line, make a bowline knot with it between the halliards and stay, and haul down.

If topgallant bowlines are fitted, knot them together between the stay and halliards, and haul down.

BY THE WIND, TOPSAIL PARREL CARRIES AWAY.

Luff to, man the weather braces, and brace the yard aback; haul up the mainsail; clew down the topsail, and

hook a tackle to the burton straps on each side from the top, to steady the yard. See that the braces bear an equal strain. Fit a temporary parrel with a pair of slings and make sail again.

Clew up the sail if thought necessary; otherwise, haul out the reef-tackles and up the buntlines.

If the mizzen topsail parrel goes, the ship must be *luffed* so as to catch the sail aback before touching the lee braces. Let a hand take aloft a pair of barrel slings, and passing the bight round the tye, toggle both parts abaft the mast; shove the bight down over the tye-block (if there is one on the yard), and lower the sail. Be careful to put the barrel slings *below* the traveler of the main topsail brace.

If before the wind, haul taut the topsail lifts; clew up the sail if blowing fresh, and hoist the yard chock up. Either fit a temporary parrel, as with the mizzen topsail, before lowering; or, if in a large ship, use the anchor strap and top burton, as already described. Snatch as far aft as possible, and walk away as the halliards are lowered. Lash the yard to the topmast rigging.

In a case of this kind, the officer of the deck must first relieve the yard with the means at his *immediate* command, such as bracing aback or clewing up; afterwards, the safety of the yard will depend upon the activity of the watch in getting up other appliances.

Spars are lost too often by the time lost in considering "what's best to be done." One of the *essentials* in seamanship is to be *always ready*.

LOWER OR TOPSAIL LIFT PARTS.

Overhaul down the burton, and hook it to the burton-strap. Haul taut and reeve new lift. Topsail lifts are only hauled taut after the second or third reefs.

THE TRUSS IS CARRIED AWAY.

Say the main-take in mainsail and main topsail. Hook and haul taut rolling tackles; send aloft the end of a hawser, take several turns round the mast and slings and haul it taut.

If by the wind, the main topsail may be clewed down and braced aback, hauling out the reef-tackles, &c., &c.

A couple of stout burtons from the mizzen pennants, hooked to straps on the main yard just outside of the slings, would answer every purpose while repairing the truss.

489

FUTTOCK BAND ON THE MAINMAST CARRIES AWAY.

This endangers the topmast, as the topmast shrouds have ceased to support it. Wear ship, if possible; if not, clew down the topsail; and if breast-backstays are carried, these, with the addition of the burtons, will support the mast while repairing the damage. If blowing hard, or if no breast-backstays are carried, send a hawser up to the masthead, take the end round and pay down on deck. Clap luffs on both ends and set up; frap both parts of the hawser together below the cross-trees.

If unable to repair the band, either fit a rope one, or bring together all the futtock shrouds that require securing, shackle them to a spare anchor shackle, and set them up with a couple of pendant tackles hooked at the partners; then frap them into the mast aloft, wedging the frapping to tauten it, and cleating below to prevent slipping. Or if unable to frap aloft, hook the pendant tackles to bolts in the water-ways on opposite sides; the starboard one, for example, being hooked in the port water-way.

NOTE. In *all* cases of carrying away the weather standing rigging, go round on the other tack if possible.

LOWER STAY CARRIED AWAY.

Run before the wind, send aloft and hook the pendant tackles; hook them well forward and haul them taut. Use the stream cable, if hemp, in fitting new stays, otherwise a large hawser. If the fore stay, shorten sail to take the strain of the main topmast off the foremast.

WEATHER LOWER SHROUDS CARRIED AWAY.

Wear ship, or take all sail off the mast. Then secure it with the pendant tackles and stream cable or largest hawser.

THE GAMMONING IS CARRIED AWAY.

Run before the wind, haul down the head sails. Hook the fore pendant tackles and set them up well forward-say to straps round the cat-heads, or to the heavy ring-bolts generally placed near the knight-heads. Come up the head stays; bring the fore topmast and jib-stays in at the hawse-holes, and set them up. Set the main topmast stays up on deck, and house the main topgallant mast. Send down the fore topgallant mast, unbend head sails, and rig in the-head booms.

490

Pass the end of the stream cable out of one hawse-hole, over the bowsprit, and in at the other. Put a heavy cleat on the bowsprit to prevent slipping. Belay one end of the stream cable to the bits, take the other to the capstan and heave it well taut. New straps would be fitted at the earliest opportunity; or, in the absence of these, a rope or chain-gammoning could be passed around the bowsprit and through a suitable hole cut through the stem head above the cheek knees. If the fid to which the gammoning sets up is still standing, pass the lashing around each end of the fid and over the bowsprit.

BOWSPRIT SHROUD CARRIED AWAY.

Go on the other tack if possible; not, haul down the head sails, and keep away. Secure the bowsprit by hooking a stout tackle from the bows to a strap round the bowsprit, and fit a new shroud or repair the old one.

SLACK LOWER RIGGING AT SEA.

It is sometimes necessary to set up the lower rigging at sea. If by the wind, and nothing to prevent going about, set up the lee rigging; tack or wear ship, and set up the other side. If the stay requires a pull, it must be first set up.

It may be, however, that the vessel is rolling heavily and no wind to steady her. In this case, measure the distance from dead-eye to dead-eye, decide on the quantity necessary to take down on each shroud, and cut the measuring battens accordingly. Take one mast at a time and get up at least eight luffs—four of a side—and put them on the four forward shrouds. Hook four pendant tackles—two on each side; have straps, &c., ready; brace in the lower yard and furl all the sail on the mast on which you are at work. Send the topgallant masts on deck.

Set up two shrouds (one pair) on each side at a time, keeping them adrift as short a time as possible. Shift the luffs from the first to the third pair of shrouds, while setting up the second pair.

Never come up *all* your lower rigging at sea, no matter how smooth the water nor how light the wind.

SCUDDING IN A HEAVY GALE.

SWIFTERING IN LOWER RIGGING.

On the passage out to China, the "Minnesota" encountered a typhoon of unusual violence, in the Indian Ocean.

491

For about eight hours it was not only impossible to carry sail, but the men could hardly be induced to show their heads above the rail.

The standing rigging, which was of Kentucky hemp, had always given much trouble by stretching; and the mainmast, which was stepped upon a *beam* over the shaft, had been evidently settling in its step.

These defects combined with the violence of the gale and rolling of the ship to render the position of the mast a very insecure one, and the officers finally became fearful, at every lee lurch, that the mast would go over the side.

The order was accordingly given to swifter in the weather main rigging. A piece of a broken topmast studding-sail boom was got up and lashed outside the rigging, about six feet above the rail. Another spar was placed outside the opposite spar-deck ports, and a heavy hawser pointed up from below, and the end taken alternately around the spar in the rigging and the spar outside the ports, until five or six turns had been taken, when each part was hove taut in succession, and frapped to the next one with selvages.

On arriving in Hong-Kong, the dead-eyes were turned out, and the rigging refitted, when it was found that the main rigging had stretched down *two inches in circumference*.

CARRYING AWAY MASTS AND SPARS.

ACCIDENTS to the lower masts and larger spars are fortunately of rare occurrence in the navy, owing to the care with which vessels of war are fitted out, and the very liberal allowance made for each in everything necessary to their equipment.

But it is probable that ships would be still more effectually prepared to resist the severest trials, if they were, in all cases, fitted out under the immediate supervision of the officer who is to command during the cruise, the first lieutenant who is to be the executive officer, and all the officers and crew who are to serve in them.

The good state of the rigging will not be the only advantage attendant upon this; a thorough knowledge of her state, and intimate acquaintance with her resources, would enable each and every one to bring them to bear when necessary.

Light yards and masts are occasionally carried away or sprung in a fresh breeze but smooth sea-topgallant masts by not having their backstays well set up, and yards by not having their weather braces sufficiently taut when braced up. Topsail and topgallant yards are also sometimes carried away by not letting go the lee brace in tacking ship, in a good swing of the after yards, when the lee brace not being properly attended to, neither the strength of the yard or brace can resist the force with which they are impelled; and if the brace holds, the yard must be carried away in the slings.

Another cause for carrying away topgallant yards may be found in the neglect to take off the lift-jigger after the topgallant studding-sail is taken in, when attempting to clew down the yard with the jigger fast in the top.

No explicit rule can be given for sending down broken spars. The first thing to be attended to is their being steadied and prevented from falling on deck or tearing the sails; then sling and guy them clear and send them down.

If the screw is in motion, guard against fouling it by the wreck.

BOWSPRIT CARRIED AWAY OR SPRUNG.

All the masts forward are deprived of the support of their stays, and there is imminent risk of losing the three topmasts (with their topgallant masts), in consequence of an accident to the bowsprit.

Should the wreck be in the water under the bows, you have no alternative, but must heave to and get clear of it. Should the wreck hang by the stays, &c., clear of the water, and you can control it in any way to prevent it from thumping a hole in the bows, get before the wind until the masts are secured, and *then* heave to as before.

With the Wreck in the Water. Heave to at once under the shortest possible sail, as trysails and spanker.

Clear away the wreck, and if a kedge with a hawser bent to it can be dropped on the *debris* so as to hang, thus converting it into a sea anchor, the ship may ride to leeward of it under low canvas, and save most of the wreck when the weather moderates.

Proceed meanwhile to secure the spars still standing; send down the topgallant masts, house the fore topmast, secure the foremast with a hawser middled and clove-hitched around the mast-head, and set up at the knight-heads or through the hawse-holes on the main deck. Clove-hitch in like manner another hawser around the fore topmast-head, and set up the ends as far forward as possible. Bring the main topmast stays down to the deck and set up.

With the Wreck hanging Clear of the Water, try to get it under temporary control with tackles hooked to straps around the lower part of the foremast, smaller purchases from the cat-head, the fish-boom and tackle, &c.

If these means will keep the wreck up clear of the bows, put the ship before the wind until the masts are

secured. The strain on the masts when before the wind is taken off the fore and aft stays, and you thus get a better chance of saving these spars, and when these are secured, heave to and ride by the wreck as before. Rig a jury bowsprit with the spare jib-boom or a topmast. Secure the fore topmast well and set fore topmast staysail on a stay to the jury bowsprit.

If the bowsprit is sprung, take all strain off of it. Fish the bowsprit and set up the stays again.

If very badly sprung, rig in the jib-boom until the heel rests against the stem. Place the flying-jib-boom on one side and a topmast studding-sail boom on the other, and woold all together, wedging and chocking up between. Set up the head stays again, and make what sail the spar will bear.

LOWER MAST CARRIED AWAY OR SPRUNG.

Say the foremast is carried away. Secure the main topmast if it still stands, clewing up the main topsail; and house main and mizzen topgallant masts, if still standing; the main topgallant mast and main topmast, however, would probably go. Clear away the wreck and try to bring it on the weather bow, and ride to leeward of it under storm staysails if possible. Cut the rigging clear of the head spars still standing.

If the main mast goes over the side, wear ship if possible, and bring it to windward.

When a mast goes over the side, *first*, get clear of the wreck; *secondly*, secure spars still standing, and then think. about rigging jury masts.

If a foremast is sprung, say near the hounds, take all sail off the mast, reeve the top pendants, send down fore topgallant mast, secure main topmast, and hook the fore jeers. Lower the fore yard and house the topmast until the heel comes below the defect; hang the heel in a chain from the tressle-trees; fish the mast with side fishes, and woold round all. Wedge well the woolding; turn in the topmast rigging afresh and set it up. Sway the fore yard up as high as it will go. Set the foresail and fore topsail with as many reefs as necessary.

If sprung lower down, first take in all sail set on the mast, and relieve it from all the strain possible; and then fish it with the fishes allowed. Iron bands are furnished in the outfit large enough to take the mast and fishes. They open with a hinge, and can be quickly put on, in case of a mast being badly wounded in action, for example.

The U.S.S. "Benicia" having sprung her foremast near the hounds, fished it very neatly with a trysail mast lashed and woolded abaft the mast.

TO RIG A JURY FOREMAST.

Take the main topmast, rest its heel against the stump of the foremast, and launch its head over the knight-heads. Put on the cross-trees and bolsters; fit the rigging and stays from hawsers, or what is saved of the old rigging. Lash the heel to the stump, and cleat on either side sufficiently to prevent slipping while raising. Hook a couple of tackles to the jury mast-head and take them to the sides. Raise the mast with a tackle hooked well aft, and the main pendant-tackles, or a small pair of sheers. When up, lash the heel to the stump, and put heavy cleats before and on either side of it. Set up the rigging and head stays. Send aloft the topmast cap and topgallant mast, fit a topsail yard for a lower one; a topgallant for a topsail yard, and bend

main topsail and topgallant sail for foresail and fore topsail.

Use, if possible, the spare lower cap, fitted on the stump, to assist in holding the topmast.

Shore up the deck under the jury mast to take the downward thrust when the rigging is set up.

MAIN TOPMAST CARRIED AWAY.

Reeve the pendants through the top-blocks; secure the mizzen topgallant and royal mast; up mainsail if set; bend the lee pendant to the wreck to leeward; cut the topsail yard clear if possible and send it down, first clewing up the top sail. Send the wreck down, assisting with the main pendant-tackles and lee fore topsail halliards. Cut the laniards of the stays and rigging at once, if necessary.

Send the stump down next, and proceed to send aloft a new topmast.

If a topmast is sprung, lower it as in the case of a sprung lower mast, until the defective part comes below the lower tressle-trees, then woold as there described.

If sprung near the head, it can be fished with the topgallant mast and light fishes, &c., as before. Reef the topsail and set it.

TO SEND DOWN THE WRECK OF A TOPMAST.

A frigate in the Mediterranean, some years since, had her main topmast so shattered by lightning, that it was impossible to slack any of the rigging without the greatest danger of the mast falling, when the following plan was adopted: A light spar was attached to each side of the topmast; these spars were then lashed every three or four feet, round the spars and topmast together; when done, the mast was unfidded; two carpenters were then stationed on the lower cap to cut away the splinters, that they might not impede the lowering of the mast, and at the same time to cut the spars placed on each side of the mast, and a seaman to remove the lashings as the ends came near the cap. The mast was again lashed to a hawser in its descent, by hands stationed under the main top for that purpose; the mast was then received on deck with the greatest safety. Whereas, if the mast had been allowed to fall, much injury must have been done to the rigging, and perhaps to the ship.

TOPGALLANT MAST CARRIED AWAY.

Reeve the mast-rope through a block at the topmast-head, and send down the wreck as convenient. By hooking a snatch-block at the mast-head, and snatching the topgallant

yard rope, it may be used in sending the wreck down. If a topgallant mast is sprung, send it down and send up another.

NOTE. *All sprung* spars should be shifted if possible.

THE JIB-BOOM IS CARRIED AWAY.

Set the fore topmast staysail, heave to or reduce sail. If running free, bring by the wind. Send down fore topgallant mast. Get the wreck in with the top-burtons, or pendant-tackles on fore stay, assisting with staysail halliards, fore clew-jiggers or lee fore buntlines, as necessary. Gather in the jib and unbend it, as soon as possible. If the wreck cannot be hoisted on board, and is thumping under the bows, cut it away at once. Reeve heel-rope and send in the stump.

The fish-boom and tackle will be found useful in handling the wreck.

On board the Congress, a heavy tackle on the fore yard and the fore pendant tackle were used in getting in the wreck of a jib-boom.

TOPGALLANT YARD CARRIED AWAY.

Secure the unsupported inboard end to the topgallant rigging or at the cap. If the sail cannot be clewed up,

the easiest way to dispose of it is as follows: Cut a few mid-ship robands, and shove down the end of the royal yard rope between the sail and the yard, carry the end up forward of the sail (by taking it out on the topsail yard and dipping it forward of the clew, if need be), and hook the end into the standing part, thus forming a sort of sail strap around the middle of the sail. Have a tripping-line to the deck, forward and to windward. Cut adrift the clewlines from the clews, cut robands and head earings, and lower on the royal yard rope, hauling on the tripping-line. When the sail gets down forward of the topsail, hands on the topsail yard-arms cut adrift the sheets.

Send down one part of the topgallant yard with the royal yard rope as soon as rounded up, and the other piece with the topgallant yard rope.

If a yard-arm hangs so low that the lift cannot be got off, lower the wreck, large end first, hauling in on the lift till the yard-arm end is nearly up-and-down, lash it then to the yard-rope, cut stops and take off the lift and brace, then lower away.

Be careful to have the tripping-lines well attended, to keep the pieces of wreck from tearing the topsail in their descent.

497

TOPSAIL YARD CARRIED AWAY OR SPRUNG.

Clew up and unbend the sail, send it on deck or gather it up in the top. If the yard is broken in two, send the smaller piece down with the burtons, and then with hawser from topmast-head, send down the other piece.

If the yard is sprung send it down in the usual manner. Studding-sail booms may be triced up and down topmast rigging. Fish old yard or send up spare one.

LOWER CAP SPLITS.

Take all sail off the mast; send down topgallant mast and shift the lower cap if you have a spare one; if not, pass a lashing round the topmast and lower mast-head, which wedge; afterward, woold and wedge the cap and make sail.

THE TRESTLE-TREES ARE SPRUNG.

Take all sail off the mast; send down the topgallant mast; reeve top pendants and hook top tackles. Sway up on them until all strain is off the fid, when rack and belay. Pass a lashing round the topmast and lower mast-head, and make sail.

MAIN CHAINS CARRIED AWAY.

Go round if possible. If not, take all sail off the mast, steady it with the pendant-tackles and set the shrouds up with luffs to the cradle-bolts.

Replace what chain-plates require it with spare ones, and keep them out in place with a chock of wood between them and the ship's side; then set the rigging up properly.

MAIN YARD SPRUNG.

To send it down across the nettings and fish it, proceed as follows: Unbend and send down the sail, and send the studding-sail booms on deck if any are on the yard. Reeve the jeers and hook them, hook the burtons to the burton straps.

Hook a tackle from forward to keep the yard clear of the mast: Take the jeers to the capstan. If the ship is rolling heavily, have tackles from the mizzen pendants hooked to straps at the slings on each side to keep the yard from getting adrift after the truss is unkeyed.

32

498

Heave round and pull up on the burtons; when high enough unshackle the slings, unkey the navel bolt, and lower away, carefully tending the braces, thwartship and fore-and-aft tackles. Land the yard across the nettings and lash it. Strip it of everything in the slings, and knock off the battens. Fish the yard with the fishes on hand supplied in the vessel's outfit.

TO GET A LOWER YARD DOWN INSIDE THE RIGGING.

If the lower yard must be landed on deck to work on it, say in the port gangway, we may prepare to land the starboard yard-arm *forward*, dipping the port yard-arm inside the rigging; or by topping up, slueing the starboard yard-arm inboard forward of the mast, and landing the yard with the starboard yard-arm *aft*, and the port yard-arm *forward*.

The latter method is so much easier where smokestacks, boats, &c., are in the way, that it will be described here as performed with the main yard of the "Colorado" on the Asiatic station, Fig. 508.

The mainsail is unbent and sent down, main topsail furled, and the main yard stripped of leechline blocks, boom-irons, &c. Hang the upper jeer block in a long lashing from the topmast-head, lashing the lower jeer block to the yard at the slings, having the purchase *outside* the collar of the lower stay and on the port side of the stay, yard to land in the port gangway.

Hook a fore-and-aft tackle at the slings, and the port top-burton to the port yard-arm. Single the starboard lift; take off the port lift as soon as the burton is taut.

Haul taut the jeers, untruss and lift the yard a few feet, so that the starboard yard-arm will clear the rail in swinging in, then top up on the port top-burton, overhauling the starboard lift.

When the starboard yard-arm swings in clear of the rail, hook to it a thwartship tackle from the port waterways, and take off the starboard lift and brace. Rouse the starboard yard-arm over to the port side; when over, point it aft, hook the port main and mizzen pendant-tackles to this yard-arm to keep it clear of the deck, and guy it aft, Fig. 509. Lower on the jeers and port top-burton, letting the port yard-arm go forward.

When low enough, hook the port fore pendant-tackle to the port yard-arm. Landed where it is, the yard would be partly on the quarter-deck. By letting the fore and main pendant-tackles take the weight at their respective ends, and tending the jeers and mizzen pendant-tackle, a fore-and-aft purchase will land the yard as far forward as desired.

In sending this yard aloft, without landing it on the nettings, use the same tackles as before, with a fore-and-aft

Fig.508

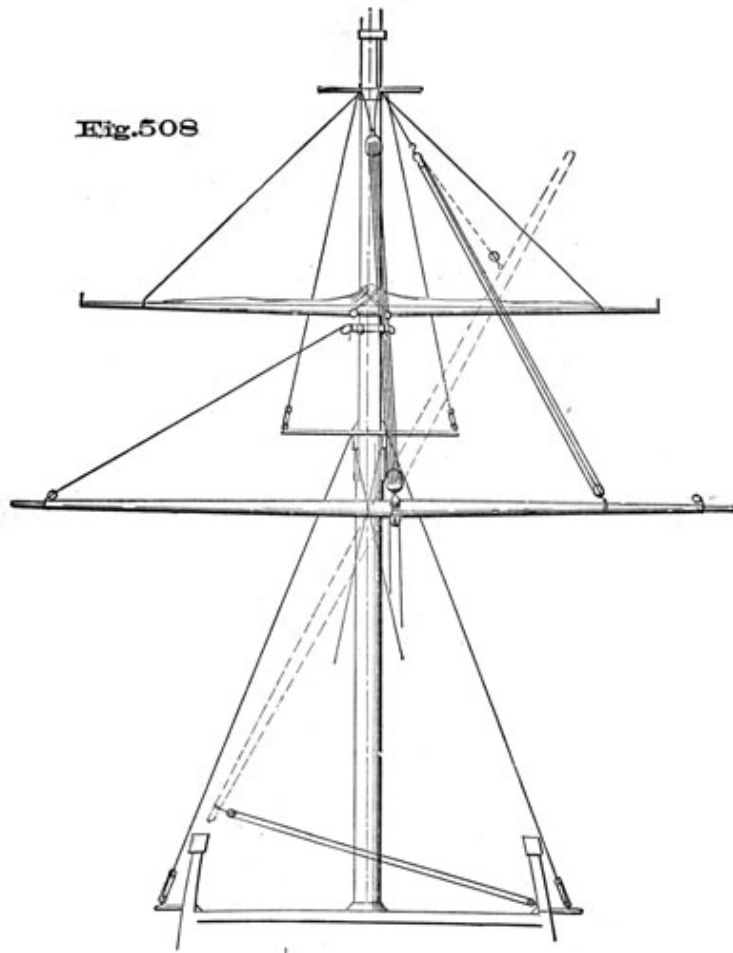
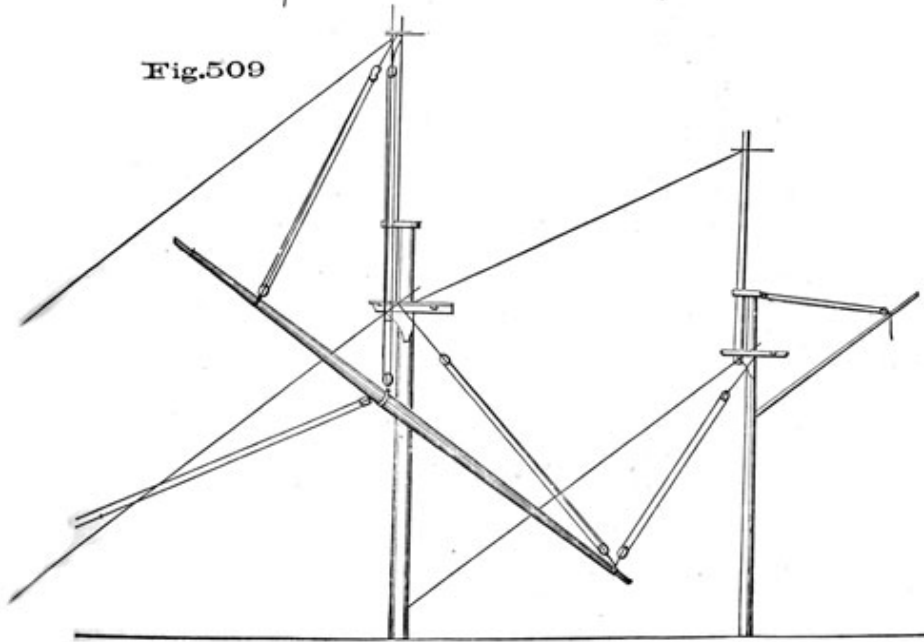
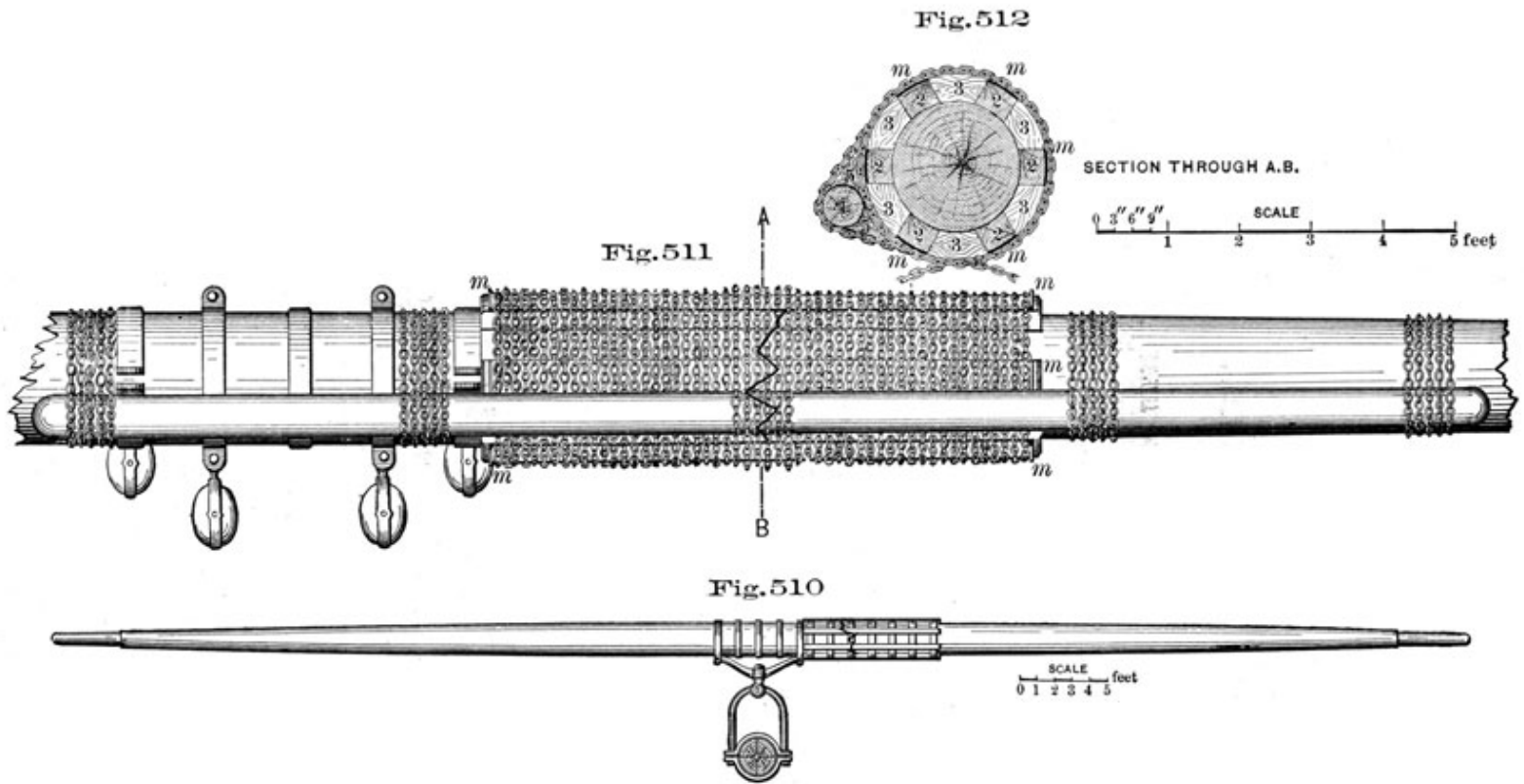


Fig.509





tackle on the after yard-arm, to get the yard aft. When far enough aft, walk away with the jeers and then with the port top-burton as soon as the starboard yard-arm will clear the deck. When high enough, unhook the main and mizzen pendant-tackles from the starboard yard-arm, rouse that yard-arm over to starboard, place the lift and brace, and hook also the starboard top-burton to assist in squaring.

Sway up on the jeers, ease out the starboard yard-arm, and commence topping it up as soon as clear, tending the port top-burton. The yard being across, key the navel bolt, hook the slings, shackle the port lift and brace block, square the yard by the lifts and braces, and send down the purchases.

When the yard comes on deck, have casks or solid chocks ready to land it on.

It is well to stop the port fore brace out of the way, to avoid fouling the upper yard-arm.

In sending the yard aloft again, it may be desired to get it athwartships, reeve lifts and braces, and then sway aloft. In that case, as soon as the starboard yard-arm has been pointed out clear, stand by to lower on the jeers and port burton, pulling up on the starboard burton.

The mast-head pendant-tackle (jeers) used on board the Colorado was of six-inch rope.

SENDING DOWN AND FISHING A LOWER YARD.

(PLATE 121.)

In March, 1880, the U. S. frigate Constitution, Captain O. F. Stanton commanding, while beating up the Caribbean Sea, carried away her fore yard in the slings. The account of the measures taken to repair damages has been kindly furnished by Captain Stanton the accompanying plate is taken from drawings made by Carpenter J. S. Thatcher, who effected the repairs.

"The yard broke short off about seven feet from the slings, on the starboard quarter. The ship at the time was on the starboard tack, under three-reefed topsails, whole foresail, main trysail, spanker and fore topmast staysail; the trade wind blowing very fresh and the sea high. The part of the yard where the break occurred swung to the deck, being eased down in a measure by the drawing of the staples of the bending

jackstay, and was secured to the fore topsail sheet bitt. The lee clew of the topsail was taken in at once, the fore lift was hauled taut, and weather topsail sheet kept fast to keep the yard-arm aloft till it could be secured to the top-rim. This done, the weather clew of the topsail was hauled up, and also the lee clew of the foresail, neither sail being injured. The topsail sheets were unrove,

500

the weather one taken to the fore tack bumpkin, the lee one to the gangway, and the fore topsail set flying with the three reefs in. The fore trysail and the fore storm staysail were set. A top-burton was hooked on the yard-arm at the top-rim, and the piece lowered to the deck. The lee part of the yard remained in place, being supported by the truss, lee lift and lee brace; a water-whip was put on as a forward brace, and the foresail sent on deck with the buntlines. The upper jeer block was slung with a long strap from the topmast-head, so that it hung on a level with the lower cap. The lower jeer block was lashed to the yard as usual, and a stout fore-and-aft tackle put on the yard; this part of the yard was then squared by the forward brace, swayed up till high enough to dip the yard-arm inside the lee rigging, and lowered into the lee gangway with the yard-arm aft. The truss was taken off. The starboard piece of yard was lifted with pendant-tackles, placed with the other, end to end at the break, and chocked to keep the pieces in line.

"A strong double purchase with luffs was clapped on each portion of the yard, and the parts hove closely together, cautiously at first, to insure the splintered portions taking the right direction, and then as taut as they would bear. By this means the pieces were forced back to within a quarter of an inch of their original positions.

"Fishes of yellow pine plank four inches thick, eight inches wide, and twelve feet long, were spiked on the yard over the break (each piece being slightly saucered on the underside), except on the *under forward* quarter of the yard, where space was left for a long fish made of a spare fore gaff. Iron mast and yard fishes were then put on over the wooden ones. The woolding consisted of the boats' anchor chains, each turn of chain being hove taut by small tackles across the deck and nailed through the links to the wooden fishes.

"Plate 121, Fig. 510, shows the yard fished and ready for woolding, and the dotted line is about where the yard was broken off. Fig. 511 shows the fishes woolded with chain, and the whole re-enforced with a spare trysail gaff. Fig. 512 is a transverse sectional view. The parts marked 2 show the position of the fishes. The parts marked 3 show the position of the chocks fitted snugly between the fishes, and spaced about nine inches apart (see Fig. 510). These chocks held the fishes in place and made the whole more rigid. The part marked 4 shows position of spare gaff. At the points *m, m, m*, under the woolding chain, are the positions of the iron fishes. These, while serving to strengthen the wooden ones, caused the chain to render easily as each turn of the woolding was hove taut. They were of the kind usually furnished to ships of war. Fig. 512 also shows a full turn of the chain around the yard and a full turn around the spare gaff.

501

"The parts marked 5 show how the space between the chain around the yard and the chain around the gaff was filled in.

"In sending the yard aloft, the lower jeer block was lashed to the slings, the upper one remaining slung from the topmast-head, burtons were hooked to the quarters and yard-arms, and thwartship and fore-and-aft tackles hooked and tended.

"The jeer fall was taken to the spar deck capstan, and a good strain kept on the forward yard-arm and quarter bur-tons. As the yard moved forward, the forward yard-arm was raised by the burtons over the starboard bow, and the port yard-arm canted outside the port fore rigging; the yard was then lowered *a portoise*. The truss was hoisted up and bolted on, and the lifts and braces rove and the yard swayed up by the jeer fall, burtons and lifts; tending the fore-and-aft tackle. The foresail was bent and set. Two top-burtons were kept on the broken side of the yard, and a jumper tackle put on when blowing fresh. The chain woolding was afterwards covered with canvas and painted, to prevent rust getting on the foresail. The enlarged part of the yard took against the fore stay on the starboard tack and against the fore rigging when the ship was on the port tack, but could be braced within about a point of the original amount, and the ship worked to windward almost as well as usual. The yard was ready for sending up the morning following the day of the accident, and stood perfectly well during very heavy weather experienced on the passage North.

"When the ship arrived at Hampton Roads, the steam-launch, which stowed inboard on the starboard side, was hoisted out with the fished fore and the main yard, and no signs of giving way could be detected."

To Make a Temporary Lower Yard. The two topmast studding-sail booms are equal in length to the lower yard.

With these for the length, the yard is made up by the most convenient spare spars, woolding all together with a number of well-stretched lashings.

CHAPTER XXXII.

SHIFTING SAILS AND SPARS.

SPLITTING SAILS.

SAILS, when split, should be taken in and repaired aloft if possible; if not, then shifted. The new sail should be ready on deck, and can be sent up to windward as the old one goes down to leeward. If the sail splits so as to be of no further use, unbend and send down at once. If not, keep it on the ship until the new one is ready.

A reef-tackle-crangle, or any part of the leech, can readily be repaired aloft by the sailmaker, in moderate weather. The officer of the deck need only clew up the clew requiring repairs. Men on the yard gather the sail up, the yard being, of course, clewed down. In chase, or being chased, it is absolutely necessary to shift sails (if required to do so at all) quickly. If carrying studding-sails on one side only, the others can be shifted over and set if anything happens to those already set.

If the jib splits, set the fore topmast staysail, cautioning the man at the helm to "mind his weather helm;" take in spanker if necessary.

If the foresail or fore topsail splits, take the sail in, repair it aloft or shift it. Reduce after sail to *balance* the ship. Caution the helmsman as before.

If a topsail splits across the head, or if, in turning out a reef, the sail is torn, and it is not convenient to shift it, take the reef in again.

TO SHIFT A JIB.

Haul the sail down-gather it on the boom, and put on good stops.

Unhook the tack, unshackle the sheets, and bend a rope's end for an inhaul to the clew, passing it out to leeward.

Hook the halliards to a strap round the sail, cut adrift the hanks, or untoggle them.

Pull up the halliards! Ease away the downhaul!

When high enough, ease in the sail on the lee side-haul in on the inhaul.

503

When on the forecastle, shift the gear to the new sail.

Pull up the jib halliards! Haul out on the jib downhaul.

Lower the jib down to the boom, hook the tack and shackle the jib sheets; secure the hanks to the head of the sail, and the downhaul and halliards to the head cringle; take off the strap, cut stops, and when ready: *Let go the downhaul!* HOIST AWAY!

TO SHIFT A TOPSAIL

(BY THE WIND, UNDER ALL PLAIN SAIL).

Hook the sail burton to strap on the topmast stay.

The new sail (say the main topsail) is in the weather gangway ready for bending. Clew up the main royal and topgallant sail.

Man the main topsail clewlines and buntlines! Weather main topsail brace! Let go the main to'bo'line!

Haul taut! Clear away the sheets! CLEW UP! Settle away the main topsail halliards! Round in the weather brace!

Lay the yard nearly square, and set taut the braces. ALOFT TOPMEN! *Man the boom tricing lines!*

TRICE UP! LAY OUT! FURL AND UNBEND!

Unreeve the first and second reef-earings from the sail (supposing them to be *bull-earings*).

Unbend the topsail sheets, clewlines, bowlines, reef-tackles, robands, and head-earings, securing the bunt-robands to the buntlines. Bend a top bowline around the bunt to guy the sail clear of the top. A whip from the weather topsail yard-arm bent also at the bunt will keep the sail from going too far to leeward, if any such trouble is expected.

Lower the sail down to leeward by the buntlines.

Send up the new sail, with the sail burton before and to windward of the stay. Bend a bowline to the sail strap as soon as it can be reached from the top.

When the clews are above the top-*High enough!*

See the turns out of the sail.

Hook the reef-tackles, carry out the head-earings from the bunt to the yard-arms, and haul out. Bring to and bend the sail. Shift the reef-tackles to their own cringles, bend the sheets, clewlines, bowlines and buntlines, the latter being rounded up. Loose the sail. Reeve the bull-earings; when the forepart of the top is clear of men, *Stand by!* LET FALL!

SHEET HOME! LAY IN! DOWN BOOMS! (secure boom-ends with the strap and toggle). LAY DOWN FROM ALOFT!

Man the main topsail halliards! Tend the braces, let go and overhaul the gear! Haul taut!

504

HOIST AWAY THE TOPSAIL!

Set the topgallant sail and royal; steady out the top bowline.

TO SHIFT A COURSE (MODERATE WEATHER).

The new sail (mainsail) being ready, stretched across the deck forward of the mast, yardarm-jiggers on the yard, lee lift taut-

Main clew garnets and buntlines!

Haul taut! UP MAINSAIL!

ALOFT MAINYARD MEN!

LAY OUT! FURL AND UNBEND!

Furl the sail; unhook reef-pendants; stop buntlines to head of sail. When ready

Stand by the earings! EASE AWAY! Lower away the buntlines!

All the gear coming down with the sail. Unbend and bend to new sail, stopping buntlines and leechlines to the head. When ready-

Man the yardarm jiggers, buntlines and leechlines!

Buntlines and yard-arm jiggers are manned best, a few hands on the clew-garnets and leechlines, hands to light up tacks and sheets.

Haul taut! SWAY ALOFT! HAUL OUT AND BRING TO!

The yard-arm jiggers are run out, leechlines hauled up; bend the sail, loose it and hook the reef pendants.

Man the main tack and sheet! and set the sail.

UNBENDING SAILS IN BLOWING WEATHER.

Previous to the order being given to unbend sails, let every man stationed on the yards be provided with a sail-tie, or a length of spun-yarn, sufficiently long to go twice round the sail. Every man takes his stop aloft, and when he has seen his robands clear, he then passes his stop twice round the sail, keeping his yard-gaskets fast until the sail is quite ready for easing in. Sails may be unbent in this manner without danger almost in any weather, in case the gaskets are not secured to the sail, as they should be; but in any event, the additional stops are valuable.

TO SHIFT A COURSE IN A GALE.

Suppose, for instance, that you have split a reefed course, and wish to replace it by another.

Haul it up as in blowing weather; cast off a few of the reef-points and robands along the yard, and clap on

505

several good stops around the sail; secure the buntlines around the body of the sail, and then cast off all the reef-points, robands, reef-earings, and leechlines; cast off the lee head-earring and rouse the lee clew, by a line from the top, into the body of the sail, and secure it to the buntlines; then, having a line from the deck forward attached to the body of the sail, ease off the weather-earring, and lower away.

Having the other sail in readiness, stretched across the deck, and properly furled for bending; bend the gear, and proceed as described for a course in "Bending Sail, Port Exercise." Man buntlines, leechlines, and yard-arm jiggers. SWAY ALOFT! Bring the sail to the yard square, with a taut head, hook the reef-pendants, hook the clew jiggers to them, and rouse them well up; bend and reef the sail, shackle the tacks and sheets, hook the clew-garnets, and set it as in blowing fresh.

If the bunt jigger is led temporarily through a bull's-eye or slip-rope secured to the chain slings of the yard, and then hooked to its glut and stopped to the centre of the head, it will help materially in getting the midship roband opposite its proper place.

TO SHIFT A CLOSE-REEFED TOPSAIL IN A GALE.

Having split, say a close-reefed main topsail, in a gale, to shift it.

Proceed as in taking in a close-reefed topsail, lay out, furl and unbend.

The men on the yards cast off the reef-points of the close-reef, and untoggle beackets of other reefs. Pass the gaskets around the sails, and use sail-ties in addition, cast off the reef-earings, retain first and second reef-earings on the yard (bull-earings), the others go with the sail.

Brace in the main yard till it is square. Send down the sail by the buntlines; unbend all the other gear. Reeve a line from the weather side of the deck well forward, over the lower stay, through the lee head-earring cringle, make fast to the weather head-earring cringle.

A whip from the weather yard-arm to the bunt (topmast studding-sail halliards) will, in this case, be a necessity.

When ready for sending down, ease away the lee-earring, haul away on the tripping-line, rousing it over the stay. Ease away the weather earring, hauling on the tripping-line, and tending the yard-arm whip. When both earrings are well clear and pointing to windward of all and forward, ease away on the buntlines.

If the main yard cannot be squared (mainsail set), prepare to send the sail down to leeward; lead the tripping-line through the weather head-earring cringle to the lee one, and

506

get the weather part of the sail to leeward of the stay first. Then ease away the lee Baring.

In this case we will need a top bowline to the bunt as a forward guy, the lead of the tripping-line being too much up-and-down to answer that purpose.

Were the tripping-line carried far forward in sending down to leeward, it would give the sail too much swing.

The topmen aloft now put on yard-arm jiggers, and have everything ready for bending the new sail.

The latter is sent aloft by the sail burton, and if properly fitted, made up as furled, it is bent as under ordinary circumstances; when the gear and sail are bent, loose the sail, shackle the reef-tackles to their proper cringles, haul them taut, the clewlines and buntlines hauled up snug, take any number of reefs required. Send the men in and down from aloft, sheet home and sway the yard clear of the cap.

REEFING ON THE FOOT.

But should the topsail not be fitted with gaskets, to be sent aloft as furled, the old custom may be followed of reefing *on the foot*, before going aloft, as follows:

Stretch the close-reef band taut along the deck, take the clews as near where they will haul up as possible, trace the clews down clear to the foot of the sail, haul the foot taut without moving the clews out of their places; gather up the foot as near the close-reef as possible, tie the close-reef points around the foot, keeping the reef knots near at hand to be ready for casting off; use rope-yarn stops to secure all the other reefs in succession around the foot, the yarns going from the forward jackstay of each reef-band around to its after jackstay; roll up the sail snug, clews and buntline toggles out, and send it aloft by a sail burton with a strap around the bunt.

When bent, take each reef in succession, cutting the rope-yarns that secure the forward and after reefing jack-stays of each reef together around the foot; for the close-reef cast off the points.

In this manner the sail is bent without exposing more than one reef at a time, until the close-reefed sail is set.

Topsails with French reefs are very convenient for sending up reefed in this manner.

In sending the new sail aloft, use the yard-arm guy to keep it well to windward.

All being ready for setting, *Man the lee sheet, tend the gear! Haul taut! Ease down lee clewline! HAUL HOME TO LEEWARD! Ease down weather clewline! HAUL HOME TO WINDWARD!* Hoist the yard clear of the cap and steady it. Haul taut reef-tackles to relieve the close-reef earrings. The

main yard is braced up sharper than the topsail yard before sheeting home.

Reefing on the foot is rarely practised, the method of making up the sail as furled being preferred.

NOTE. In sending down a topsail, it is all-important to point it fair, before lowering. Therefore, try to keep it well to windward, clear of the lower stay.

The fore storm-staysail can be hauled down and storm-mizzen set if necessary to keep the ship to.

In sending a sail down or up when running with the wind abaft the beam, first heave the ship to if it can be done.

If a main topsail splits, when lying to, of course it must be unbent immediately, and the other sent up when ready; but if we wish merely to shift the sail, have the new one ready before starting anything aloft.

TO SHIFT A COURSE WHILE THE OTHER IS SET.

If, in chase, you are unwilling to lose the effect of a course, while replacing it by another, you may perform both operations at once, thus:

Get the one you wish to bend (which we will distinguish as the new one), stretched across the deck under the yard; get up the yard-arm jiggers, and hook them to the first reef-cringles of the new sail; unbend the buntlines from the foot of the old sail, haul up the ends, and send them down between the yard and the old sail; bend them to the new one, stopping them to the head. Stopper the clews of the old sail, and shackle the tack and sheet blocks to the clews of the new one; the topmast studding-sail halliards may be bent to the head-earings of the old sail to lower it by.

While this is doing, the men on the yard will hook the bunt-jigger and stop the leechlines to the head of the old sail; cast off the robands.

Man the yard-arm jiggers and buntlines, and run the new sail up to the yard abaft the old one; while bringing the head of the former to the yard, the latter is lowered on deck by the bunt-jigger, leechlines, and head-earings, lines being attached to the head cringles to lower by; after the old sail is down, bend the leechlines to the new one.

SHIFTING A TOPSAIL

WHILE THE OTHER SAIL IS STILL SET.

This evolution can only be practised when the ship is going free, with any benefit to her speed. It has been done by some good officers in the following manner: We will

508

suppose the fore topsail the one to be shifted; middle the sail to be bent across the fore stays, stopper the clews of the topsail, unbend the fore topsail sheets and buntlines, have the burtons on the fore topsail yard-arms, and well boused taut. Have good whips on the topsail yard-arms, overhaul them down, bend them on to the first reef-cringles of the new sail; the head earings should be hitched to the whips. Send a light burton down before the old sail, and hook it in the centre of the head of the new sail; single the topsail sheets, and bend them to the clews of the new sail, bend the buntlines to the proper places on the foot of the new sail, but do not make fast the robands to them; bend a tripping-line to the head of the new sail by the robands, about half way out on the head of the sail, so as to keep the sail going up clear of the one bent. When all is quite ready, man everything together, and send the sail up as a flying sail; be careful to get a good pull of the reef-tackles, before the men lay out on the yard to unbend and bend sails. It will require the greatest care in displacing the earings of one sail, and passing the earings of the other; when the robands are fast, you may let the old sail hang by the reef-tackles, then run the clewlines up high enough for sending the sail on deck, with the help of the burton at the mast-head, which must be shifted abaft the topsail yard for the purpose.

Use topmast studding-sail halliards for the yard-arm whips, in case the studding-sails are not set.

TO SHIFT A TOPGALLANT SAIL OR ROYAL.

Take in and furl the sail, unbend the gear, send the yard on deck, shift, cross the yard, bend the gear, and set the sail.

On board of a first-rate, a topgallant sail may be unbent aloft, sent down by the royal yard-rope or topgallant studding-sail halliards, and the new sail sent aloft by the same means, and bent, hauling the earings out by hand.

TO SHIFT A TOPMAST STUDDING-SAIL BOOM.

Having carried away the starboard boom, to replace it by the port one, the latter being rigged in.

The topmast studding-sail would of course be taken in as quickly as possible, and the outboard end of the boom with it. The inboard end would probably be lowered on deck with the boom tricing-line and a whip from the lower lift.

Put a whip on the port lower lift, secure its end to the port boom outside the quarter-iron. Have a guy from forward secured to the boom at the same place as the whip. Take

Plate 122

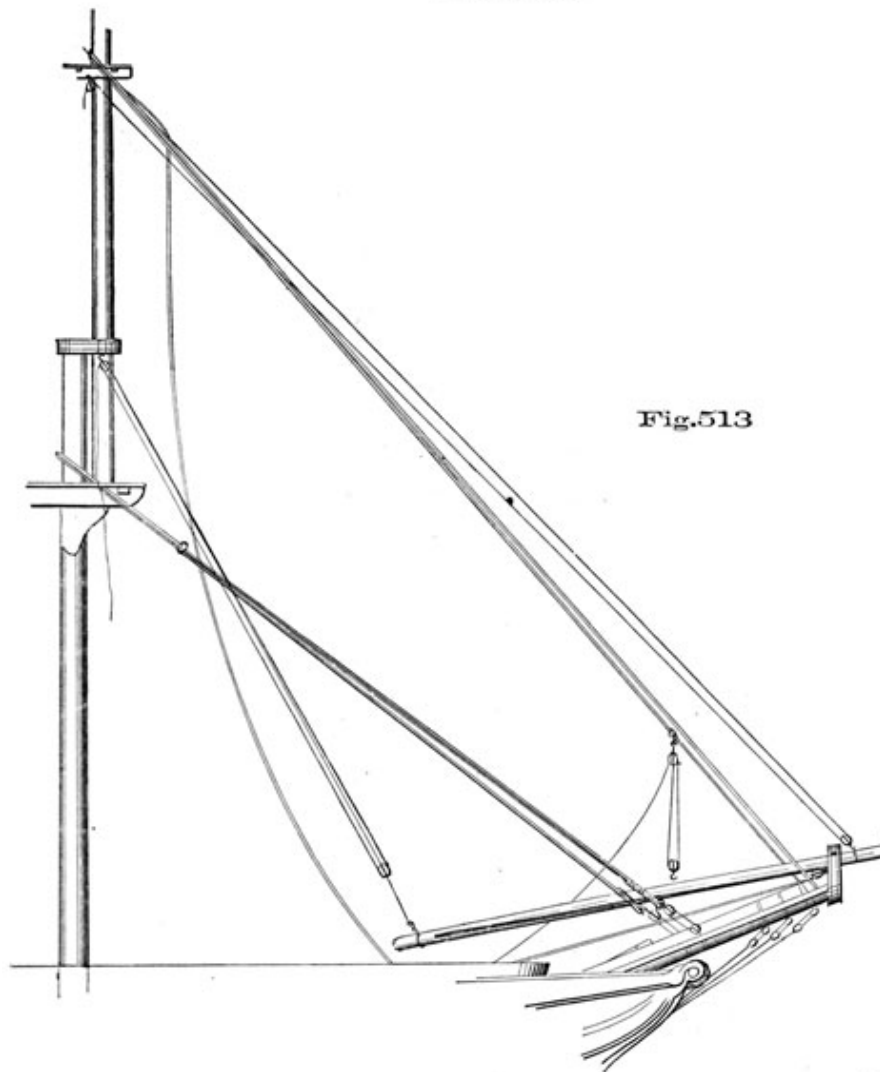
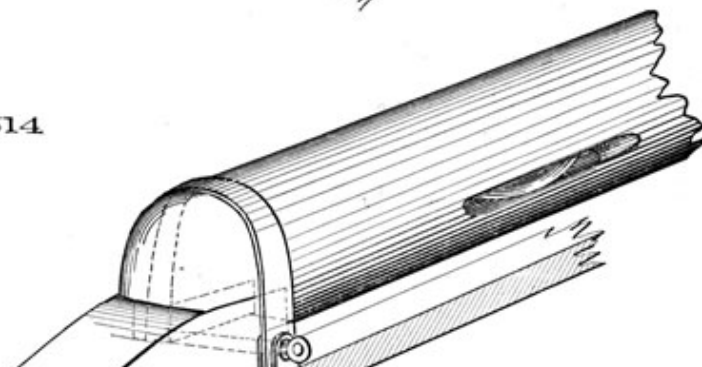
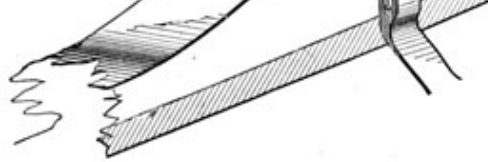


Fig.514





off the lower studding-sail halliard block and tack block, unless the latter is permanent, in which case unreeve the tack.

Launch the boom in clear of the boom-iron, the tricing-line being hooked at the heel, set taut the whip on the lower lift and trice the heel of the boom above the lower yard, unclamping the quarter-iron. Lift the boom out of the quarter-iron and lower on the yard-arm whip, hauling forward on the guy.

There should be a backlashing from the whip *outboard* to keep it from slipping in. When the boom is up-and-down, the heel hung by the tricing-line, cast off the guy and port whip, carry the outboard end of the spar over to starboard, and bend on the whip from the starboard lift; also a guy from forward, starboard side. The usual back-lashing will be needed on the whip to keep it from slipping inboard. Haul on the whip, tend the forward guy, and land the boom in the starboard quarter-iron, clamping it. Launch the end out through the boom-iron, rig the end (tack and studding-sail halliard block), take off whip and guy, and prepare for rigging out and setting the studding-sail. If not intending to set the lower studding-sail, rig the usual jumper with the lower studding-sail halliards.

TO SHIFT JIB-BOOM. (Figs. 513 and 514.)

The foreclemen and fore topmen prepare for housing fore topgallant mast, and for rigging in flying jib-boom. In addition, the men stationed on the jib-boom, lay out; carry out and hook the cap block, and reeve the heel rope; hook jiggers to topmast stay and whisker ends; cast adrift topmast staysail and jib, and hook jib halliards to jib-boom end; hook tackle from topmast stay to light in boom by; hook fore clew-jiggers to heel of jib-boom. The foreclemen on deck place the new jib-boom on the forecastle ready for going out; ease up back ropes, jumpers, guys and jib-stay, take a turn and tend jib halliards, man fore clew-jiggers and jiggers on the topmast stays.

If the wythe is fitted to unclamp, the stays rove through the flying jib-boom need not be unrove. Otherwise, and in the absence of funnels on the head booms, the stays reeving through them must be unrove and stopped up.

Rig in the flying jib-boom, and house the topgallant mast: then-

A turn with the mast rope! Haul taut the jib heel rope! Tend the jib halliards! unclamp the heel of boom, ease up the jib halliards to allow the boom to clear the saddle; a few hands man the fore clew-jiggers and jiggers on the whiskers. When ready-

Ease away! RIG IN! easing the heel rope until the band

is close to the bowsprit cap; the jib halliards and fore clew-jiggers are hauled on sufficient to keep the heel of the boom high enough to just clear the knight-heads; the whiskers are triced up to the fore topmast stays, the jib and flying-jib are roused in alongside the topmast staysail. As soon as the boom is housed close in

A turn with the heel rope! let go the jib halliards; lash the bands to the bowsprit cap; hook the tackle from the fore topmast stay to a strap around the jib-boom just inside the bowsprit cap, haul it taut, take a turn.

Tend the stay-tackles! Walk away with the fore clew-jiggers! at the same time ease away on the heel rope, and land the boom on the forecastle; cast off from bowsprit cap and unreeve the heel rope and reeve it on the new boom; shift the stay-tackle and fore clew-jiggers from the old to the new boom.

Man the heel rope and stay-tackle; tend the fore clew-jiggers; when ready-

Haul away the stay-tackle and heel rope! walk the boom out until pointed.

Avast hauling; tend the stay jiggers and jib halliards! The band is placed; the stay-tackle is cast adrift, the jib halliards are hooked to the boom end, hauled taut and tended; the stay jiggers on the whiskers are tended; when the boom is rigged, stay rove, &c., order-

RIG OUT! the men walk away on the heel rope; ease away on the fore clew-jiggers until the boom is clear of the knight-heads, and when clear, let go and cast them off; ease away the jib halliards and stay jiggers; when the boom is far enough out to take in the saddle, pull up the jib halliards and secure the clamp.

Point the flying jib-boom; at the same time the men proceed to take off stay-tackle and jiggers, and to set up guys, jumpers, back ropes and jib stay. Man the topgallant mast rope as soon as the jib-boom is in place, fid the topgallant mast, rig out and secure the flying jib-boom. Bend jib and flying jib.

Instead of sending down the topgallant mast in ordinary weather, lash the light yards aloft, overhaul the yard ropes (the long ones) down well forward; toggle them abaft their sheaves in the mast, and set them up with jiggers, forward.

TO SHIFT A TOPGALLANT MAST.

Send down the royal and topgallant yard, unreeve the yard ropes rove through the mast sheaves, come up topgallant and royal rigging and Jacob's ladder laniards.

Start and attend backstays and stays, hanging the back-stays in the top.

511

SWAY AWAY!-out fid-LOWER AWAY!-out preventer-fid.(if used).

Pass the lizard as the head of the mast comes below the cap.

Bear the heel off the topsail yard.

Lower the mast on deck-*heel aft*, and after side up. Shift the mast rope and lizard to the new mast, taking care to see it clear of turns. Have jiggers ready on the backstays.

SWAY ALOFT!

Cast off the lizard as soon as the mast-head enters above the topmast tressle-trees.

Clamp the gate.

Place the royal rigging and truck, and reeve the royal yard rope

Place the jack and topgallant funnel-reeve the topgallant yard rope

Enter the preventer-fid as soon as possible-light up all the rigging. SWAY TO FID!

When the fid is entered, *Launch!*

Steady taut the stays and rigging.

Cross the topgallant and royal yards.

At sea, when under close-reefed topsails, the mast is sent down abaft, and to windward of the topsail yard.

As before stated, a hole should be bored in the heel of the topgallant mast above the proper fid-hole, for the preventer-fid, as a mast rope frequently carries away in the final pull.

TO SHIFT A TOPSAIL YARD.

For a yard tackle, to send down the yard, use the top-burton, if good; otherwise, trice up and hook at the

top-mast-head any luff purchase with a four or five-inch fall, long enough to reach from the topmast-head to the deck. The lower block of the yard purchase hooks to the slings of the yard.

Hook the quarter blocks to the lower cap.

If there is but little wind while shifting the yard, hitch the bight of the buntlines and one bowline around the sail amidships.

Unbend the gear, man the buntlines on deck, and at the order to "ease away, lay in," run the sail up nearly to the topmast-head, and keep it clear of the yard purchase by the bowline; let it hang till the yard is sent up and crossed, then lower and bend in the usual manner.

But, if blowing fresh, the quickest way will be to furl and unbend, send the sail on deck by the buntlines, and sway it aloft again after the yard has been shifted. The

512

sail may be left in the top, but will probably be found very much in the way.

Trice up the fly-block with top jiggers, unshackle the tye-blocks from the yard.

Take the tack-blocks off the topgallant studding-sail booms, hitching the tack round the strap of the block.

Get the studding-sail booms up and down the topmast rigging, with the boom tricing-line and topgallant studding-sail halliards.

Unreeve the topgallant sheets and topsail reef-tackle. Knot the end of the studding-sail halliards and round them up.

Having hooked the yard purchase at the slings, hook the port top-burton (yard to land in starboard gangway) to the port burton strap, which is an iron band on the yard well out on the port quarter.

Bend a top bowline to the slings of the yard, as a fore-and-aft guy to keep the jaws clear of the topmast and of the top, while sending down.

Tend the topsail lifts and braces, cast off the parrel, and sway away, pulling up on the yard purchase, hauling forward the guy. When the jaws are clear, trip the port yardarm by hauling on the burton. Lower away on yard purchase and burton.

Unrig the lower yard-arm on deck, and the upper yardarm in the top. Put a swab or grating under lower yardarm.

Steady the lower yard-arm well forward, to keep the upper yard-arm close to the top while taking off the gear aloft.

Take off the boom-irons, jewel-blocks, first and second reef-earings, and unshackle the lifts and braces.

When the rigging is taken off, keep it clear for the new yard. Have a marrying line for the starboard lift.

Finally, lower the yard on deck, lower yard-arm aft, easing the burton. This leaves the yard pivoted on the yard purchase, and easy to manage. If the yard must be transported, use tackles from the fore and main.

Shift the burton and yard purchase to the new yard, and SWAY ALOFT!

When up-and-down, rig the new yard as the old one was unrigged.

A bowline bent to the upper quarter of the yard will keep it clear of the fore part of the top.

Attend the lifts and braces, SWAY ALOFT! Have the starboard burton hooked to its burton strap to assist in squaring the yard. As the yard rises above the cap, pull up on the starboard lift and burton, slacking the port burton. When the jaws are fair, slack away the fore-and-aft tackle. Pass the parrel, secure the lifts, take off the burtons.

Reeve the reef-tackles and the topgallant sheets.

Replace the studding-sail booms and their tack-blocks.

Secure the quarter-blocks, the standing part of topsail

513

clewlines, and shackle the tye-blocks. Take off the yard purchase.

Sway aloft and bend the sail.

Haul home the topsail sheets and hoist the topsail.

In shifting a yard at sea, send it up or down on the weather side. Take the course in and square the lower yard.

After crossing the new yard, if the jaws have fallen to leeward, or the yard does not rest fairly on the cap, and consequently will not allow the parrel to be passed taut at once, use a rolling tackle to rouse it over to windward and the top bowline to haul it forward.

TO SHIFT A TOPMAST.

Send up both top-pendants and two tackles.

One top-pendant, say the port one (at the main), reeves through a top-block on one side of the lower cap, through the dumb sheave in the topmast, and its end is secured on the opposite side of the cap. The other top-pendant reeves through a block on the opposite side of the cap, then through the thimble of a lizard with two good tails, through the live sheave of the topmast, and its end is secured to a bolt in the lower cap on the opposite side.

The fid-hole being athwartships; each of the sheaves is at an angle of 45° from it, and they are at an angle of 90° from each other.

Send the topgallant studding-sails down out of the top. Any ropes or whips which may be wanted must be hung from the top rim, to prevent their getting under the topmast rigging as the mast comes down. Hang all the backstays abreast the top, or from the lower mast-head.

Send down topgallant yard and mast, getting them both on deck.

Secure the topgallant and royal funnels, and the truck on the fore part of the cross-trees.

Cast off the catharpin lashings on one side.

Secure the topgallant studding-sail booms and the bunt of the topsail to the topsail yard, bend the top bowlines to

the slings, cast off the parrel, attend the topsail halliards, braces and lifts, haul forward on the bowlines. Let go the reef-tackles and topgallant sheets, and when clear of the lower cap, lower the topsail yard across the fore part of the top, lashing it there. Clear away the topmast rigging, backstays, and stays, starting all the laniards, except one stay and the weather backstays, which are attended as the mast is swayed. Man the top tackle falls. Let go the topsail halliards and lifts, and all the ropes that go to the topmast-head. SWAY AWAY!-out fid-LOWER AWAY!

The top pendants now supplied are long enough to lower the mast on deck. After the mast is unfidded, take a turn

33

with the top pendants, and unhook the top tackles, taking their straps off the pendants. The upper blocks of the top-tackles remain hung aloft ready for use in fidding the new mast. In all cases where the top-tackles are clapped on the pendants, keep a turn with the pendants themselves. Lower the topmast by the top pendants, bracing up the lower yard if necessary.*

When the tressle-trees are a few feet above the lower cap, stopper that pendant which reeves through the live sheave, and have about two fathoms of it abaft the stopper clear for surging, then belay it well. Overhaul the other pendant, which will drop clear of the dumb sheave. If the hanging blocks are not taken off, haul them and the topmast rigging taut out under the cross-trees. Have lashings from the lower cap to steady the cross-trees. See all the men clear.

Let go the stopper on the top pendant, surge the topmast.

If the tressle-trees hang the mast, take the top pendant to the capstan, or clap the top-tackle on it, heave the mast up and surge as before. If need be, hang the topmast rigging by stops to the cap.

When the mast-head is clear, secure the topmast cross-trees, funnel and cap on top of the lower cap. Pass the two tails of the lizard round the topmast, *below the hounds*, taking two round turns with each tail and then knotting them together; hang the lizard with a small rope from the topmast-head to keep it from slipping down. If there is a sheave in the head of the topmast, hang the lizard from there.

Lower the topmast with the heel down the hatchway forward of the mast until the head is clear of the tressle-trees. Bend the end of a whip from forward to the mast-head and haul forward; when the head is before the top rim, take the top pendant to the capstan, or clap a deck-tackle on it. Hook a burton from aft to the heel; when the heel is above the coaming of the hatchway, haul aft on the burton, lower on the top pendant and land the mast on deck.

Suppose the new topmast (main) to be stowed on the starboard side of the booms, head forward. Launch it aft till the hounds are about on a line with the foot of the mast. Reeve the starboard top pendant through the live sheave, secure it to its own part, forming a long bight or strap from the heel, and lashing the bight around the topmast well below the hounds. Clap a top-tackle on the pendant, and pull up, tending the heel of the topmast, get the mast up-and-down, and point the heel down through the

* With the latest patent truss, the topmast is sent down through it. If the truss is otherwise fitted, the yard must be untrussed and hauled forward, and braced out of the way if necessary. In this case the lift on the side braced *up* will take against the topsail yard; hook a top-burton to the lower cap, and to the lower yard *forward* of the topsail yard, steady it taut and overhaul the: lower lift abaft.

515

scuttle, lower away till the head is clear of the collar of the stay, point the head fair between the tressle-trees, and pull up on the top-tackle. Just before the hounds enter between the tressle-trees, snatch the other top pendant in the dumb sheave, clap the port top-tackle on it, and when it takes the weight of the mast, secure the end of the starboard top pendant to its eye-bolt at the cap. Walk away with the top-tackles, the mast taking the weight of the rigging, topmast cap, &c., as it goes aloft. When the yard-tackles are nearly two blocks, stopper and belay the ends of the pendants on deck, overhaul down whips (lower clew-jiggers) from the top, hook them on to the upper top-tackle blocks, and fleet these purchases and their straps as far up on the pendants as possible. Now sway up to fid, lighting up the rigging as necessary, and with tackles on the backstays to steady the mast.

When the mast is fidded, square the lower yard and truss it if untrussed; stay the topmast and set up the rigging; get the topsail yard into place, and sway aloft and fid the topgallant mast. After setting up the topgallant rigging, send up the light yards.

Send down top pendants, blocks and top-tackles as convenient.

TO HOUSE TOPMASTS, AND SEND DOWN LOWER YARDS.

The topgallant masts and yards having been sent down, send aloft the top pendants, top tackles and jeers. The lower yards are sent down first, and then the topmasts. If the ship is rolling, use thwartship tackles on the lower yards. Hook fore-and-aft tackles; single the lower lifts and hook the burtons to the burton-straps. Be prepared aloft to unkey trusses and unhook slings. Come up topmast rigging and stays, but be careful in easing the fore-and-aft stays, not to ease more than absolutely necessary.

The jeers may be worked on the gun-deck of a frigate and taken to the capstan. Have *seamen* to lower.

When the top-tackles are hauled taut to unfid, the topsail lifts, buntlines, and reef-tackles must be well overhauled, especially if this gear has been thoroughly wet, and has consequently shrunk; the laniards of topmast rigging must be overhauled. It is a good plan to hang the backstays and halliards aloft from the lower cap, as in swaying up much weight is saved.

The lower booms must be gotten alongside before the lower yards are sent down, and the flying-jib and jib-booms must come in with the topgallant masts and topmasts.

Some seamen think lower yards hold less wind aloft, and braced up; and others disapprove of sending down lower yards and housing topmasts both; and the evolution at present is seldom performed.

516

If at anchor where you might be required to get under way to save the ship, do not strike the lower yards or house topmasts.

When the top-tackles are swayed upon, we must not forget to overhaul the topsail halliards, and the halliards of the head sails; in fact, everything leading to the topmast-heads. The gear of the courses, such as leechlines, &c., must be attended.

Everything being manned and attended, the command is. given to sway up and heave round; the braces, lifts, fore-and-aft tackles, burtons, thwartship tackles, topsail sheets, are either manned or tended as required. The topmen tend stays, backstays, and laniards of topmast rigging, and overhaul all other rigging necessary. *Lower away* when the trusses and slings are clear, and fids out. Rest the lower yards on blocking in the nettings, and lash the heels of the topmasts to the lower masts. Keep a strain on the jeers, so that the yards will not sag amidships.

The bights of the topmast rigging are hung over the edge of the top. The whiskers and dolphin striker are triced in, the ends of the former lashed together. Stop the parts of the head stays above the bowsprit to the fore stays, and the parts under the bowsprit to the bowsprit shrouds.

The topsail yards are lowered across the tops.

TO FID TOPMASTS AND SWAY UP LOWER YARDS.

On the moderating of the gale, the topmasts must be fided and the lower yards sent up.

Before starting top-tackles or jeers, all rigging, such as backstays, halliards, &c., &c., should be well overhauled and hung from the top, and have jiggers and luffs on the stays and backstays, to steady the masts as they go up, and to be ready for setting up. The fore-and-aft stays, topsail lifts, &c., should be overhauled beyond the old nips, so as to leave the masts free for going up. All running gear, such as reef-tackles, buntlines, and head-halliards, must be well overhauled.

If there is not force enough in the ship, fid the topmasts first, then send up the lower yards.

When all is ready, having top-tackle falls manned, and jeer falls led to capstan, luffs, &c., tended, sway up and heave round, fid and stay topmasts, key trusses and hook slings. Having set up the stays, backstays and topmast rigging, get the topsail-yards in place, and send up the topgallant masts and light yards.

HANDLING SHIP IN COMING TO ANCHOR.**GENERAL REMARKS ON ANCHORING.**

SHIPS, on getting within signal distance of the senior officer, are required to show their number, and on this being recognized, that officer gives his number in return.

Local signals, or temporary additions to the signal books, general orders, and copies of the squadron routine, should be procured without delay after joining company.

Shortening all sail together, in coming to anchor, however well done aloft, cannot but crowd the decks at a time when you want silence and the power of carrying out a sudden alteration in your plans. Except when you want to "charge" into a station with great way, or catch breezes over the land with your lofty canvas, the seamanlike way to come to is under topsails, after the courses and upper sails have been taken in and the upper yards squared. You can then feel your way with the topsails, deaden it with a check of the braces, freshen it with a small addition of canvas, or stop it by heaving aback.

When about to shorten sail, get the marks on the lee lower lifts down; clew up; man all the braces, and lower and square all together.

In coming in, while blowing hard, get as much sail reefed and furled as you can spare with prudence, and the cables double-bitted. If running, round to before letting go, and have hands by the second anchor ready for letting go.

Always double-bitt before anchoring in deep water, as at Madeira, and similar anchorages.

Should you use a buoy, do not part with it until veering obliges you to do so.

The rolling motion may be checked, when at anchor, provided there be not too much wind, by making sail and bracing by. This is no unimportant object, especially in handling boats.

No one who could help it would moor in a roadstead. At single anchor a ship is ready for sea, and her remaining anchors are disposable for a gale from any quarter.

The common rule for giving the proper scope to ride by, in moderate weather, is six times the depth of water.

518

In coming to an anchor, it is desirable to run the cable out straight, clear of the anchor, after letting go. To do this we must either wait for sternway before letting go, or else let go while there is headway on, and pay out roundly.

For the former there must be wind enough (if there is no tide) to force the ship astern. In the latter, there is the chance of damaging the copper and snapping the chain, and thus of running on board a vessel which we had reckoned on clearing. It is evidently an unnecessary risk in strong breezes, and therefore only adopted in light ones, where the risk is small. The mizzen topsail is often set aback to give the ship sternboard.

The object in thus laying out the cable is, that not only will the anchor be clear, but that (except in strong breezes and tides) the ship will ride far from her anchor by the mere weight of the chain, where it rises from the bottom.

PREPARATIONS FOR ENTERING PORT.

It will be assumed that the ship has had a long and boisterous passage, and that she is approaching her port of destination under favorable circumstances, pleasant weather, and with a reasonable prospect of making a speedy run in.

On striking soundings, bend chains and get the anchors off the bows. A day or two before making the

port, send down any extra rigging that may be aloft, scrape and grease spars, get the upper masts in line, and see that all the square marks are on the lifts and braces. Scrub paint-work inside and out, and if found necessary give the ship a light coat of paint outside, by rubbing off with rags steeped in oil and lampblack. Touch up all chafes on the spars aloft. The morning before going in, holystone decks, and scrub boats, spars, and oars. Sling clean hammocks the evening before.

As you near the port, send down all chafing gear, lower the boat davits and square the boats, having them all ready for lowering, have all the half ports squared, and see that no lines are towing overboard. Have sentry boards placed, and sentries ready for posting, the accommodation ladder scrubbed and ready for shipping. All sheets snug home, and sails up taut; clew-jiggers hooked, if used. If anticipating a long stay in port, the studding-sails may be unbent, the gear unrove, tallied, and stowed away. If intending to moor immediately after anchoring, rig the capstan for the chain of the anchor first let go, unless the bars will be in the way. The officers and crew should be dressed in the uniform prescribed by the captain. Every preparation should be made for firing a salute, and the flags to be used in readiness.

519

Sometimes the topsail sheets and fore and main tacks and sheets are singled to facilitate shortening sail.

If coming in under steam alone, have all the sails neatly furled, yards squared, and rigging hauled taut.

On approaching a port at any time, day or night, have the colors set. If it has been too dark to make out the colors upon the ship's entering port, they are usually ordered to be hoisted at daybreak the next morning.

Upon nearing the anchorage, the officer of the deck, when so ordered, directs the boatswain to call "BRING SHIP TO ANCHOR! The first lieutenant then takes the trumpet, and officers and crew repair to their stations. The officers, following the executive, repair in the order of rank to the forecastle, main deck, starboard and port gangways and mizzen mast. The navigator, or other officer assigned to this duty, will see that both anchors are ready for letting go, that the chains are bitted and clear for running, compressors thrown back, with men to man the falls, hook-ropes, stoppers, &c., at hand.

Should the navigator have charge of the ground tackle, he returns to the bridge, to pilot the ship in.

The junior officers are distributed about the ship to the best advantage.

The principal stations of the crew are at the wheel, lead, anchors, conn, signals, clew-jiggers and buntlines, down-hauls and brails, and weather braces. Hands by tacks and sheets, halliards, outhauls, bowlines, lee braces, and on the lower yards to overhaul the topsail sheets. Also hands by the compressors, and hook-rope on the main deck.

Only those men stationed aloft will go there; all others must keep below the rail, out of the chains and clear of the ports. Care should be taken that the general appearance of the ship is neat and seamanlike.

For detail of duties of the men stationed at the anchors at the order LET GO! see Chapter XIV., page 247.

If a senior officer's ship is lying in the port, observe the disposition made of his light spars, and, if need be, make the usual signals and all preparations for sending down light yards and masts, should his be on deck. Sway at the order LAY DOWN FROM ALOFT! after furling sail, but lower carefully while men are in the rigging.

A vessel entering port with light yards in the rigging should make similar preparations for crossing them on anchoring if the senior officer has his light yards across.

As soon as the sails are furled, lay down all but the square yard men, send a boat ahead, square yards haul taut and stop in rigging, and pipe down.

Get the lower booms out, rigged for port, and lower boats according to circumstances. When coming in under steam alone, the former are generally rigged out as soon as the anchor is let go. At the same time, circumstances permitting,

run up the jack if the topgallant yards are across, and fire the first gun of the salute.

The catamaran should be ready, so that the copper may be scrubbed and oiled the morning after coming to.

Immediately after anchoring, the navigator gets bearings of the prominent objects in sight, that the ship's position may be plotted on the chart. These bearings must be entered in the log.

On piping down, the first lieutenant gives up the deck to the officer of the watch.

HAVING A LEADING WIND,

TO RUN IN AND ANCHOR. (NO TIDE.)

BRING SHIP TO ANCHOR! See that all the officers and crew are on deck and at their stations. TOP-GALLANT AND ROYAL YARDMEN IN THE TOPS! *Stand by to take in all the studding-sails and royals!* After the men are stationed, take them in, giving the order, *Haul taut!* IN STUDDING-SAILS AND ROYALS! Or give the order for the stun' sails in detail. Rig in and get alongside the studding-sail booms, make up and stow away the sails, trice up the gear, take the burtons off the topsail yard, and jiggers off the top-gallant lifts, if used.

Man the top-gallant clewlines! Fore clew-garnets and buntlines! and when ready, *Haul taut!* IN TOP-GALLANT SAILS, UP FORESAIL!

FURL THE TOP-GALLANT SAILS AND ROYALS! The moment this order is given, the light-yard men should lay aloft from the top, and after furling the sails snugly, lay down on deck.

Square the lower yards by the lifts, and let the captains of the tops square the top-gallant and royal yards.

Man the topsail clew-jiggers and buntlines; jib downhaul! spanker outhaul! At this order hands lay out on lower yards to overhaul topsail sheets. Have hands stationed by the topsail sheets and halliards, jib halliards and spanker brails, and to attend the braces. Bear the spanker boom over on the quarter.

When near the anchorage, put the helm to starboard or port, as the case may be, having allowed for head-reach in bringing her to the wind. Then give the order, *Haul taut! Let go the topsail sheets!* CLEW UP! HAUL DOWN THE JIB! HAUL OUT THE SPANKER! As soon as the sails shake, having the wind abeam, *Settle away the topsail halliards!* SQUARE AWAY! Take in the slack of the braces as the yards come down, keeping them square. The buntlines are hauled up above the yard, the clews hauled forward by the clew-jiggers.

521

She comes to the wind by the effect of the helm and spanker, and as soon as she loses entirely her headway give the orders, *Stand clear of the starboard (or port) chain!* LET GO THE STARBOARD (or port) ANCHOR! *Spanker brails!* and as soon as she swings to the anchor, BRAIL UP THE SPANKER! Direct the navigator * as to the scope to be given, he reporting the order carried out when the chain is secured; furl sails, square yards, haul taut rigging, and pipe down.

If coming in before the wind, or with the wind well aft, the head sails may be down, or hauled down before shortening sail.

If the crew has been well drilled, all the studding-sails, top-gallant sails, royals, and foresail may be taken in together; and this, when well done, has a fine effect.

The best command to give on such occasions, where everything is started together, is:

Haul taut! SHORTEN SAIL!

This should be done in time sufficient to admit of getting the sails, booms, and gear out of the way before taking in the topsails.

The top-gallant sails and royals should be furled at once, when clewed up. To this end it is well to have the light-yard men on the jack and cross-trees ready to lay out the moment the yards are down.

It is not advisable to attempt to reduce a cloud of canvas at once, unless the crew and rigging are in such a state as to insure success.

TO COME TO "HEAD ON."

If there is not room to take the necessary sweep, in coming to anchor with the wind aft, check-stoppers may be put on the cable to deaden the headway. Having clewed up the sails in good time, furl them, that you may approach the anchorage with as little headway as possible. The anchor being let go, the checks, breaking one after the other, serve to stop her headway before the range is veered to. If no cable is ranged, have careful hands at the compressors.

TO STAND IN ON A WIND AND ANCHOR.

Coming to anchor with the yards braced up, you must have the weather braces well manned, and have hands ready to square the lower lifts, before the topsails are clewed up; and the moment the order is given to *clew up*, let the braces be hauled in, and the lower lifts hauled taut to the

* As before stated, the duties of the navigator in connection with the chains in coming to or getting under way are frequently performed by a watch officer, the navigator remaining on the spar-deck to pilot the ship.

522

square mark. Some officers square the yards by the braces before they clew up the sails. This hastens to stop her headway, and it is necessary in some cases, as, for instance, in coming to in a crowded harbor, or where you have little room. But it renders the operation of clewing up difficult, from the sails being aback and binding against the rigging. Others clew up the topsails, and then, manning all the weather braces, order, *Settle away the topsail halliards!* SQUARE AWAY! When circumstances permit, this is preferable.

As soon as the cable is taut and the anchor ahead, "veer to" on the cable, giving it to her as she will take it.'

Standing in on a bowline under all sail, the most approved method is to shorten sail to topsails, jib, and spanker, and to come to under that sail.

Everything being in readiness, give the command-

Man the fore and main clew garnets and buntlines!

Top-gallant and royal clewlines, flying jib downhaul!

*Aloft top-gallant and royal yard men!**

Having hands by the tacks, sheets, halliards, and lee braces, and weather top-gallant and royal braces manned, order, Haul taut!

SHORTEN SAIL!

The sails are clewed up, yards clewed down, and squared in by the braces.

FURL THE TOP-GALLANT SAILS AND ROYALS, STOW THE FLYING-JIB.

Next order-

Man the topsail clew jiggers and buntlines!

Jib downhaul!

At this order the men stationed there lay out on the lower yards to overhaul topsail sheets, and a few hands are sent to the spanker sheet.

Stand by the starboard (or port) anchor!

When it is judged that the ship can be luffed up into her berth, order the helm

Hard down!

Haul taut!

Let go the jib halliards! HAUL DOWN!

Clear away the topsail sheets! CLEW UP!

The spanker sheet is now hauled over till the boom is amidships; the jib is hauled down snug, and the topsails clewed up. Then-

Man the weather braces! Stand by the topsail halliards!

Settle away the topsail halliards! SQUARE AWAY!

At this order the topsail halliards are settled away roundly, and the braces hauled in to the square marks.

The quartermaster in the chains, judging by his lead, will report when headway ceases; as soon as the ship

* This presupposes the light-yard men have already been sent into the tops.

523

commences going astern, *Stand clear of the starboard chain!* LET GO THE STARBOARD ANCHOR! If a buoy is used, first, *Stream the buoy!*

When head to wind, put the wheel amidships and secure it, and brail up the spanker.

Let her take the chain from the locker if she will, and do not pay it down in a lump under the forefoot. If the wind is so light that, even with the mizzen topsail set, she will not take the chain, you must wait either for the tide or a stronger breeze to send her astern.

The anchor being down-

STATIONS FOR FURLING SAIL!

Man the bunt-jiggers, have hands by the clew-jiggers and buntlines, &c., and proceed to furl. Should it be found, after clewing up, that the ship head reaches too much, and is in danger of fouling another vessel, sheet home and hoist the mizzen topsail. Should this prove insufficient, drop the foresail.

TO ANCHOR WITH A SCANT WIND.

Running in with a scant but good working breeze, a ship, by a series of *half-boards*, might work up in a crowded harbor to a position not otherwise attainable, the manoeuvre being attended with greater success with a favorable tide.

Or having the yards braced sharp up, and everybody at their stations, *Clear away the topsail sheets!* CLEW UP! and keeping fast the halliards that the yards may remain pointed to the wind, stand on under jib and spanker, luffing all she will. *Man all the weather braces! Jib downhaul! Hands by the topsail halliards! Lee fore and main lifts!* and when up to your berth, HAUL AFT THE SPANKER SHEET! *Hard down!* HAUL DOWN THE JIB! *Settle away the topsail halliards!* SQUARE AWAY! When she loses headway, let go the anchor, furl sails, square yards, haul taut the rigging, and pipe down.

TO ANCHOR HEAD TO WIND IN A NARROW CHANNEL.

Stand in close to one side of the channel, and when nearly abreast of the berth clew up the fore and main topsails, at the same time hauling down the jib. Put the helm down, haul out the spanker, and brace the mizzen topsail sharp aback. When head to wind, let go the anchor and clew up.

Anchoring in a narrow channel or harbor, with the intention of mooring, you will let go the first anchor on the weather shore, and moor with an open hawse, either in or out of the harbor, to the prevailing wind.

The necessity of these precautions will appear evident if

524

you should ever find yourself riding to a gale of wind with a cross or elbow in the hawse, cables chafing each other and injuring the cut water.

BEATING IN ON A FLOOD TIDE, TO ANCHOR.

If, having a head wind, and tide favorable, you work up, you will, when near the anchorage, put the Vessel before the wind; and, keeping her under the management of the helm, with sufficient sail set to stem the current, you may, by reducing or making sail, drop with the tide, shoot ahead, or sheer to either side with the helm, until you have arrived at the proper spot for anchoring.

Always come to, however, with the head of the ship to that which is the stronger, either the wind or the tide. Let the last tack be that which will bring you close to the weather shore; reduce sail to the jib; put the helm up, and wear short round till the ship's head approaches the flood tide (should the tide prevail), then down jib; let go the anchor and furl sails; otherwise anchor as if no tide.

Unless the wind be very light, sail should be furled as it is taken in, lest she overrun her chain.

FREE WIND AND EBB TIDE, TO ANCHOR.

Having the tide running out, with a fresh breeze in your favor, and having, by sufficient sail, forced your way through the water to the anchorage, reduce sail until she becomes stationary, when you may let go the anchor. Furl sail at once.

In a tideway you usually moor with one anchor up and the other down the stream.

RUNNING UNDER DOUBLE-REEFED FORE AND MAIN

TOPSAILS AND FORESAIL, TO ANCHOR.

After bending the bower chains, rouse up and bend both sheet chains; get the upper yards on deck; send down the top-gallant masts, send the studding-sails out of the tops; get up and reeve top-pendants and jeers, and make all preparations, before coming to, to house topmasts, and send down lower yards immediately after anchoring, if required. Weather-bit the chains and have the compressors well manned. As you near the harbor, haul up the foresail, and take in and furl the fore-topsail.* Have reefed spanker or storm mizzen ready for hauling out.

* The main topsail might be clewed up at this time and a head sail hoisted, which would suffice to give the necessary headway, and decrease the chances of broaching to.

525

Clew up the main-topsail when some distance from your berth, and when near it put the helm hard down and haul out the spanker. Send the men aloft to furl the foresail and main-topsail, and as she rounds to, with the wind on the bow, let go the weather bower and veer away roundly. When out to a good scope, from forty-five to sixty fathoms, according to the depth of water, let go the lee bower, and when head to wind, brail up the spanker. Bring her up gradually, veering to from ninety to one hundred and twenty fathoms on the first, and forty-five to sixty on the second.

Bring an equal strain on both cables and stopper well. Now house topmasts, &c., &c., if necessary.

ANCHORING OFF A COAST,

OR IN A ROADSTEAD, WHERE IT WILL BE NECESSARY TO GET UNDER WAY IN CASE OF BAD WEATHER.

In anchoring off coasts, or in exposed roadsteads, preparations must immediately be made for slipping and going to sea in case of bad weather. In coming to in such a case, we would let go that anchor *from* which we expect to cast when slipping. If anchoring off Tampico, for example, let go the port anchor, as, if we slip, it will be in a *norther*. Before furling sails, single-reef the courses and double-reef the topsails. Have storm sails bent, and be prepared for a gale at any moment. Make all preparations for slipping.

While lying at anchor under these circumstances, hoist boats, stowing inboard, every night if you are using them; all the davit boats will, of course, be hoisted. The officer of the deck, at night, should see the topsail sheets clear, unless the ship has steam up ready for going ahead at short notice. Have a hand by the drift lead.

Upon the first indication of bad weather all hands will be called, and, if time, the anchor hove up; otherwise the chain must be slipped. All anchors are kept ready for letting go; for something *might* occur to prevent slipping.

IN EXPECTATION OF BEING FOULED

BY ANOTHER SHIP DRIFTING DOWN FROM AHEAD.

Send hands aloft to drop the foresail, screw down the forward compressor, unshackle the cable, bend on a hawser, and, as the vessel approaches, slip, and give her a wide berth. A head sail hoisted, with the sheet to windward, may assist in canting your vessel clear of the danger. In a fresh breeze, stand by to veer instead of unshackling.

526

If collision is unavoidable, get the swinging boom alongside, lower the quarter boat and lower deck ports, overhaul lower lifts, and brace the yards up on the tack opposite to, the side the ship is on. If a vessel gets athwart your hawse in a strong tide, probably the easiest way to clear is to send a kedge astern, set taut the hawser, and wait for the tide to turn. When it does, you will swing by the stern, and the other vessel be drifted clear of you. For tending ship at single anchor, see Appendix K.

 [Previous Part](#)  [Seamanship](#)
[Home Page](#)  [Next Part](#)

Copyright (C) 2006 [Historic Naval Ships Association](#)

All Rights Reserved

[Legal Notices and Privacy Policy](#)

Version 1.00, 24 Apr 06

HANDLING "FORE-AND-AFTERS."

The student is referred for more detailed information on this subject to Qualtrough's "Sailor's Handy Book," where it is treated with special reference to yachts and yacht sailing.

We shall confine our attention chiefly to the two principal types of fore-and-afters peculiar to the waters of the United States, viz.: the two masted schooner, Fig. 515, Plate 123, and the sloop.

The Schooner has a fore and aft foresail and mainsail, both usually laced to booms and gaffs and attached to hoops on their respective masts. It has also a fore and main gaff topsail, triangular in shape, the luff attached to the topmast by hoops; the sails furling aloft at the lower masthead.

The head sails of coasting schooners are variously named according to the position of the stays.

When the forestay goes to the bowsprit cap, or nearly to it, the first head sail from inboard is the *jib*, beyond which are the flying jib and outer jib.

But if the forestay sets up at or near the knightheads, the sail set upon it is called the *fore staysail*, and the others are the jib, flying jib, and outer jib.

An additional jib, on the fore topmast stay, is called a jib topsail. Its tack lashing may have a long drift to enable the sail to hoist above the other jibs.

It will be seen from the above that the *jib* of a schooner is that sail whose tack is nearest to the bowsprit cap.

In our description of manoeuvres, &c., we assume the inner head sail to be a fore staysail.

The staysail sheet and fore and main sheets have their lower blocks strapped to a thwartship traveller. This traveller for the main sheet is a short bar of iron, and for the other sheets extends across the deck, and for the staysail sheet may be a wooden spar. Stout tail ropes or clew-ropes for the staysail and foresail enable those sails to be held to windward, if necessary, in tacking.

The foresail may be a combination of "boom and lug," in which case the forward part of the foot has the usual

Fig. 515

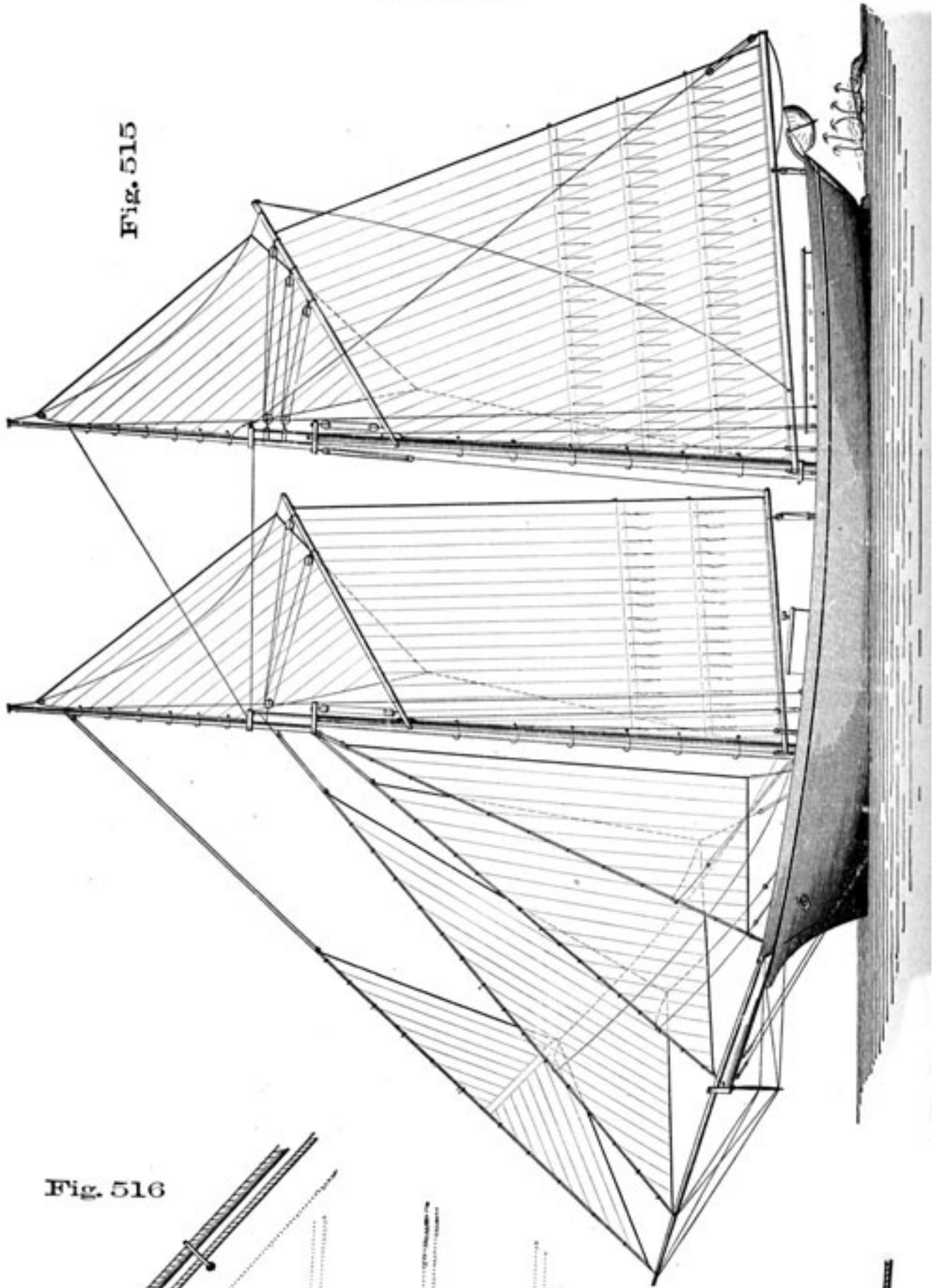
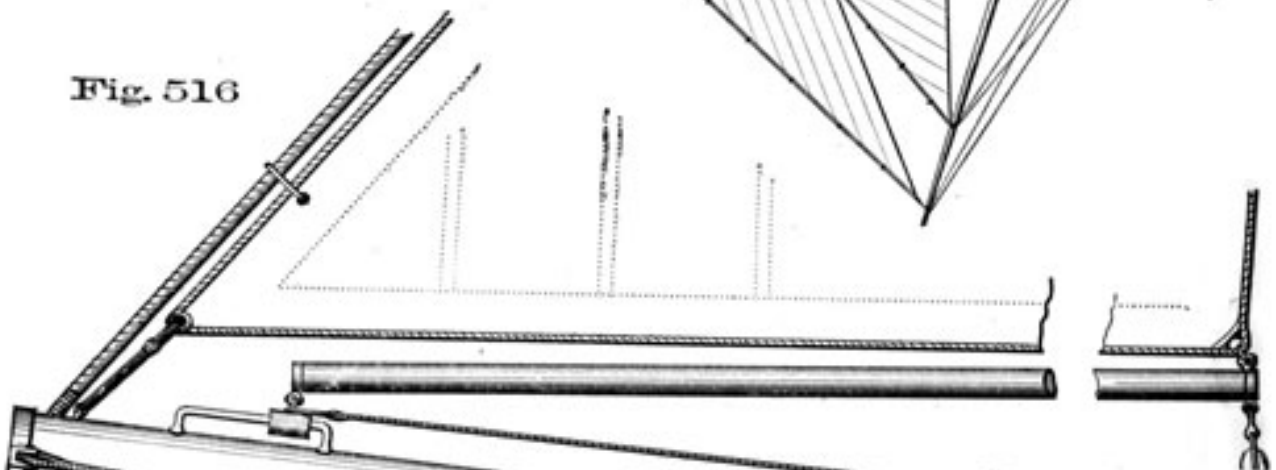


Fig. 516



boom and traveller, and the clew of the sail extends much further aft than in the ordinary type. Such a sail sets better than a common boom foresail, particularly on a wind, when the boom foresail sheet must be trimmed so flat to fill the foresail and fore gaff topsail, that much of the propelling power is lost. But the boom and lug foresail requires more attention in tacking. The lug foresail, without *any* fore boom, is rarely seen in our coasting craft.

The main mast of schooners is stayed by a *triotic* stay from one lower mast head to the other. Large schooners may have in addition a double stay to the deck, the ends setting up with runners and tackles at the waterways, abreast the after part of the fore rigging. The lee stay must be overhauled, when under way, to clear the foresail.

The main boom topping lift is usually single, shackled to a bolt in the after part of the main masthead, the lower end fitted with a whip or whip and runner with a block on the outboard end of the boom and a sheave through the boom for the hauling part. The topping lift may be double in large schooners, in which case they come further in on the boom, and the lee one must be overhauled when the sail is set.

The fore boom topping lift is a pendant supporting the boom end. The upper end of the pendant is fitted with a whip or tackle, upper block hooked under the main trestle trees, fall leading on deck.

Halliards.-The fore and main peak halliards are generally rove through three single blocks on the gaff and two double blocks on the mast-head placed vertically one above the other, the distance apart varying with the length of the gaff. The hauling part leads through one sheave of the upper block to the outer block on the gaff, back to the upper block on the mast-head, thence to second block on the gaff; then through one sheave of the lower masthead block and the inner gaff block, finally the standing part reeves through the remaining sheave of the lower masthead block and to the deck, where a purchase is fitted to the end.

Throat halliards consist of a treble block aloft and double block at the jaws of the gaff, the standing part of the halliards fitted with a purchase which generally travels on the topmast backstay, similar to the topsail halliards of a square rigged vessel.

Reef Pendants for a boom mainsail consist of a long pendant with a Mathew Walker knot in one end. The pointed end reeves up through an eyebolt on one side of the boom, through a reef cringle in the leech and down on the opposite side through a sheave on the boom. When reefing, the end of the reef pendant is hitched to the hook of the outer reef-tackle block, the inner block of the reef tackle hooking to an eyebolt under the boom.

There are no reef pendants required for the foresail,

ordinary reef earings being passed through the reef cringles lower when required, the end of the fore boom being generally lowered on deck while the reef is being taken.

Gaff Topsails.-The gaff topsail sheet reeves through a sheave in the gaff end, and thence through a block at the jaws of the gaff, and to the deck.

The halliards reeve through a block at the topmast head, or sheave in the topmast. The tack leads from the tack of the sail to the deck.*

The clewline and downhaul, in one, is secured to the clew of the sail and reeves thence through a leader at the head and down on deck.

The Sloop has but one mast, placed about two-thirds the vessel's length from the stern. The mainsail is like that of a schooner. The sloop also carries a gaff topsail similar to those already described.

The *jib* of a sloop sets on the forestay, which in this case goes to the bowsprit cap. A jib topsail is carried usually, in addition, being set upon the topmast stay.

The topping lifts, halliards, &c., are similar to those already described for schooners.

Getting under way.-*Schooners.*-Heave short, loose and hoist the mainsail, keeping the peak square with the throat until the throat is up. If the mainsail has two topping lifts, see that the gaff is hoisted between them. If the topping lift is single hoist the gaff so that it will be to *leeward* of it; the peak can then readily be dropped in case of any accident in casting. **

Get the final pull of throat and peak halliards on the purchase on the standing parts. Now, hoist the foresail and loose the head sails.

To cast to starboard, heave up the anchor, putting the helm a starboard, main boom steadied over to starboard, fore sheet trimmed down, but playing on the traveller; hoist the staysail, or staysail and jib, with the port sheets aft. When she has paid off sufficiently to starboard, "*Draw*" the head sheets, right the helm, and trim the fore and main sheets.

If blowing fresh the foresail may not be set till after casting.

If intending to wear and stand out before the wind, the peak of the mainsail may be left down until after casting.

In a close place, with little room astern, hoist the head sails before breaking ground.

* Or the gear of the gaff topsail may be named on the principle adopted with studding-sails; when the outhaul is known as the tack and the tack is called the sheet, which is the case on board many coasters.

** A *peak downhaul* should always be fitted to a gaff; it is rove through a bull's eye at the gaff end, ends of the downhaul leading to cleats on opposite sides of the boom.

34

530

Sloops.-Heave short, hoist the mainsail, clear away the jib; when ready to trip, to cast to starboard, put the helm a starboard, hoist the jib, haul the sheet to port; shove the main boom well out over the starboard quarter. Heave up, and when she has paid off sufficiently, right the helm, "*draw jib*," haul aft the main sheet.

If to stand out before the wind, leave the peak of the mainsail down until after wearing around, and shift the helm when headway begins.

Riding to the tide, in getting under way, use the helm as in casting a square rigged vessel; in casting to starboard, put the helm a port until she gathers sternboard, when it must be shifted.

Coasting vessels as a rule do not take the trouble to ease off the main sheet in casting, simply guying the boom well over to leeward, sheet trimmed ready for the first stretch.

Tacking. - *Schooners.* - Under ordinary circumstances, moderate breeze and smooth sea, clew up the fore gaff topsail, "*hard a lee*" very gradually, keeping all sheets fast just as long as they will do any good, haul all over as she comes head to wind, especially avoiding keeping the staysail sheet one instant to windward if she will pay off without its assistance. Trim the jibs down at first quick and flat, but as she gathers headway ease them slightly.

If the schooner is out of trim, or a dull sailer, or if the circumstances of wind and sea are unfavorable, the staysail sheet is held to windward to assist in paying off, and the clew rope let go at the order "*Draw*" or "*Let draw*." If she goes around with a stern board, the helm must be shifted.

When around on the other tack set the fore gaff topsail to leeward of the triatic stay by unbending and dipping the sheet aloft. In making short legs, the fore gaff topsail is not set, as a rule.

If the schooner has a boom and lug foresail, a couple of hands can take care of that part of the sail not controlled by the boom and traveller. A lug foresail requires more force, and the sheet must be hauled over briskly to avoid making a back sail of it; it is likely to foul the pins, &c., on the mast band, and is altogether unsuitable for coasting vessels with small crews. The boom foresail requires no attention.

Should the staysail not be fitted with a traveller, it will probably be because the clew comes very far aft, which will require considerable overhauling of one sheet and hauling in on another, and this is seldom done in good time. A decided disadvantage of having the clew come abaft the foremast is that it throws the wind out of the lull of the foresail.

One hand ought to take care of the flying-jib sheets on a schooner not over 100 tons; if blowing fresh, the

Many schooners are fitted with a "boom jib" (Fig. 516), the foot of the sail being secured to the boom. The outboard end of the boom is fitted with a gooseneck, the lug of which slides on a short iron rod on top of the bowsprit. When the sail is hoisted, the outer boom end is hauled aft on the traveller by a whip and runner belayed at the knightheads, which gives the foot of the sail the proper stretch.

The jib sheet is rove through a double block on the inner end of the boom, and two single blocks in the waterways-one on each side; standing part made fast to one single block, through one sheave of the boom block, then through the other single block, back through the second sheave of the boom block and the first single block, the end being belayed on the same side of the forecastle as the block which carries the standing part. By this arrangement the boom end travels to and fro *on the sheet*, avoiding the inconvenience and danger of a traveller, with its sheet sweeping the deck. To hold the jib to windward if need be, a tail rope is fitted to the inner end of the boom, clear of the double block. A light topping lift from the fore trestle-trees supports the inner end of the boom.

Sloops.-The vessel going a good full and by on the port tack, ease the helm down, when hard a starboard and the sloop is nearly head to wind, let go the jib tail rope (jib fitted with a traveller).

If she hangs in stays, trim the jib sheet to windward again as she passes the direction of the wind, in this case keeping it over to starboard, and shove the main boom well over on the port quarter. As she gathers headway on the new tack, "Draw jib," let go the clew rope and the sheet will fly to leeward on the traveller; trim aft the main sheet and right the helm.

Should the sloop in tacking gather a stern board, the helm must be shifted and put hard a port (in this case) till she gathers headway again.

A large centre-board schooner or sloop in a fresh breeze may require part of the board hauled up on going about, to prevent too much strain on the board and trunk, and to have the craft stand up better. These vessels will swing around in stays much faster than a keel vessel.

To Wear. -*Schooners.*-Clew up the main gaff topsail, if set, drop the peak of the mainsail, up helm and ease off the main sheet. While paying off, round in the slack of the main sheet just enough to keep the sail full; when the wind is aft shift over the boom and head sheets; hoist the peak of the mainsail, haul out the gaff topsail, and meet her with the helm as she comes to. The head sheets, when shifted over, should not be trimmed down flat, as that tends to prevent her coming to.

For a sloop, proceed in a similar way, clewing up the gaff topsail and dropping the peak as necessary.

Gybing.- Having the wind on one quarter, if a change of course or of the wind itself brings the wind on the other quarter, the main boom must be shifted over, and the operation is called *gybing*. To gybe a main boom, blowing fresh, is an operation requiring much skill, as it is not unfrequently attended with accidents-such as springing the boom, splitting the sail, or wrenching the masthead or jaws of the gaff.

In a smooth sea and with a moderate breeze, with the wind aft and the boom guyed out on the starboard quarter; give a careful sheer with a starboard helm, hauling the main sheet flat aft and the boom nearly amidships; then take a good turn with the sheet, shift the helm handsomely to port till the wind is on the starboard quarter, when the main sheet may be slacked off briskly but kept under control, and the vessel steadied to her course.

As a rule, the peak of the mainsail should be dropped, if only to get the gaff to leeward of the topping lift, besides rendering the operation of gybing much safer.

Many fore-and-afters (particularly sloops), instead of gybing, will, under these circumstances, frequently *luff* into the wind and come around on the other tack, thus:

The boom being off to port, luff up gradually with a port helm, hauling in the main sheet and getting the jib sheet in, but not enough to fill the sail. When she is head to wind the jib sheet is kept to port just enough to pay her off on the new tack, and as the boom comes over, the main sheet is eased off, keeping headway all the time, if possible.

A flat bottomed sloop drawing little forward will come around in rough water almost always without hauling in much of the main sheet, and, if she has a jib traveller, without hauling in the jib sheet at all, taking care to catch her at the right time with the clew rope, to make the jib assist in paying her head around. A deep keel schooner would require more management.

Wing and Wing.- In running with the wind aft, schooners with the main boom guyed out on one quarter and with the fore boom guyed out on the opposite side, are said to be "wing and wing." The main boom is guyed out by a *boom pendant*, into which hooks a tackle (boom-tackle) taken forward of the main rigging and inboard. The fore-boom is guyed forward by a similar pendant and tackle, the latter hooked to an eyebolt well forward. Small craft may use a line rove through a block on the bowsprit. The fore boom topping lift must be overhauled as required.

In running with the wind on the quarter or aft, accidents from unexpected gybing would probably be serious, and for this reason very careful steering is required.

When running in fore-and-aft vessels, to avoid the yawing and difficulty of handling the helm when before the wind, particularly in sloops, it is advisable, when circumstances

permit, to "tack to leeward," by bringing the wind well on one quarter, sailing a certain part of the required distance, and then accomplish the balance of the run with the wind on the other quarter.

Running in a gale, bear in mind the use of a drag astern, as dwelt upon elsewhere (page 479).

Squally Weather, Reefing.- In sailing a fore-and-aft vessel by the wind in squalls, it is usual to touch her up in the wind. A careful person ought to be at the helm in carrying sail in squally weather, when it is necessary to luff and touch the sails. Should the wind prove variable, in direction as well as in force, sail ought to be made snug, for if a squall should come suddenly on the quarter it would be too long a luff before the sails touch, and if it comes out ahead they will then be thrown aback.

To reef the mainsail, bring the vessel to the wind, hauling in the main sheet; lower the throat and peak halliards till the reef band is below the main boom, pass the tack lashing at the luff, hook the reef tackle to the reef pendant, and haul out the reef band close along the boom. Pass an earing through the reef cringle at the leech, come up the reef tackle and shift the pendant to the second reef cringle, in readiness for another reef. Tie the points around the foot rope of the sail, *never* around the boom. Hoist the sail finally, getting the throat taut up before the peak.

When the third (close) reef is taken, the pendant is left rove through the cringle with the reef tackle hauled taut, and acts then as a backer to the reef earing.

To take the balance reef, if fitted, ease the peak halliards enough to let the jaws of the gaff come close down, pass a lashing around the throat, fit and tie the points around the foot of the sail, and pull up the peak halliards.

The balance reef extends from the close reef-band nearly to the throat.

To Reef the Staysail (or Jib).-Being by the wind, haul down the sail, bringing the reef cringle to the bowsprit and lashing it, unhook the sheet block and hook it to the proper cringle on the leech; tie the reef points around the foot of the sail; when ready, hoist and trim aft the sheet. If fitted with a bonnet, come up the lacing or *keys*, and take the bonnet off, securing the tack and shifting the sheets as before.

To turn out Reefs. Bring the schooner or sloop to the wind, if necessary, cast off first the reef points, then the tack lashing, and finally the reef cringle lashings (earings); overhaul the reef pendant; man throat and peak halliards and sway the sail up to a taut leech.

To Heave to. *Moderate weather.* Haul flat aft the main sheet, putting the helm down, and haul the staysail sheet to windward; if a boom foresail, ease off the fore sheet to spill the wind out of the sail.

Man Overboard. If on a wind, put the helm down, throwing overboard a life buoy or grating to the man, bring the vessel around on the other tack and stand toward him.

If running free, say wind on starboard quarter and plenty of room, luff around by all means, on the opposite tack; haul in roundly the main sheet, putting the helm a port; let her luff around, but keep the jib sheet to windward (port) when about and the main boom trimmed flat. Lower the boat in stays.

Circumstances might require the vessel to heave to on the same tack (starboard tack in this case), in which event perform only the first half of the evolution, and meet her with the helm and head sheets as she comes to, but she will be further from the man, and this is not recommended. The boat in this event would pull off the weather beam.

Laying to in Heavy Weather. Concerning the best mode of laying to in heavy weather, too much depends upon the type of vessel and state of the wind and sea to lay down any fixed rules. An ordinary keel schooner of 150 to 200 tons, which has been running under a close reefed mainsail, reefed foresail and reefed fore staysail, having the hatches battened down and everything secured about the decks, is brought to the wind by easing down the helm, and with all hands on the main sheet, watching for a smooth time to put the helm down, and hauling down the staysail (generally) as she comes to. The mainsail is then lowered and the fore sheet hauled aft.

In a gale of wind, a sharp built schooner is hove to under double reefed foresail, with the sheet trimmed as on a wind, or flat, if necessary to keep the vessel from head reaching too much, and to keep the sail from shaking as she comes up head to wind. When the foresail is full, the vessel head reaches enough to keep up a certain amount of steerage way and consequent action of the rudder.

In some schooners it is frequently essential to hoist the head of the mainsail to assist in keeping them to.

Most of them are provided with a storm "trysail," similar in shape to the storm mizzen of square-rigged vessels, and used for the same purpose.

The helm should not be lashed alee, but tended as circumstances may require, and the vessel should keep steerage way if possible.

A flat-built schooner is often hove to under a balance-reefed mainsail; but if this be done she must be very flat, and when she will not lay to, in any way, under a foresail.

Shallow-built vessels, and such as have flat floors, are much more liable to be upset in a heavy sea than those of a different construction. This arises from their having so little hold upon the water, notwithstanding their great

stability in a river, or smooth sea, where it would be almost impossible to capsize them in carrying sail.

Large sloops are about the least desirable seagoing craft, their long mast and boom rendering them uncomfortable rough-weather boats, though in smooth water and going to windward they will be found the fastest. Such vessels are hove to under a few hoops of the mainsail and a storm jib, though here again the difference of model may render more after sail (as a storm trysail) necessary, and the boom may have to be well eased off. In this case, and indeed in any seaway, the boom should be well topped up.

The usefulness of a drag as a sea-anchor in riding out a gale may be reiterated here. The form of drag which probably gives the best results is that of a stout conical bag of canvas, with a heavy iron ring at the mouth. The ring may be hinged for facility of stowage, but in such a way that it will only close in the direction of the apex of the cone. The drag is fitted with a bridle at the mouth, to which is secured the riding hawser or cable; a tripping line from the point of the cone allows the drag to be canted for hauling in. The iron ring at the mouth should be heavy enough to keep the drag below the surface of the water.

Anchoring. Coming in on a wind, round to to leeward of your berth, haul down the head sails, and as she comes to the wind, meet her with the helm; keep her head to wind till headway is lost, then let go the anchor, and as she drops astern pay out the chain; lower and furl the sails.

If running to an anchorage before the wind, get the head sails and foresail (a schooner) down in good season to present no opposition to coming to.

When the helm is put down, drop the peak of the mainsail if blowing very fresh, haul the main boom amidships, and when she comes head to wind keep her so till headway ceases, then let go the anchor and pay out the chain as she takes it.

Beating in on a strong flood, lower fore and mainsail, wear around under jib, and when head to tide haul down jib and let go the anchor.

The Topsail Schooner. A class of vessel not especially considered in these notes may be briefly referred to here.

In getting such a vessel under way the yards are braced abox to pay her off; in tacking, the yards are handled like the head yards of a square-rigged vessel, and by the same orders. In running, the topsail, close-reefed, will be found a useful sail, but the reefed fore staysail and main trysail (or close-reefed foresail, according to the model) should be ready for setting in case it becomes necessary to heave to.

It must be recollected that the *lee* sheet of a schooner's topsail should be the first clewed up, otherwise it may get over the lee yard-arm, on account of the sail having

proportionally more spread at the foot than square-rigged vessels in general. Again, a schooner's weatherbraces must not be too *taut*, from the liability to part, or to carry away the yard, by the spring of the masts. In squally weather the *square* sails should be furled.

The topsail schooner rig is almost entirely superseded on the coast of the United States by the hermaphrodite brig.

Yacht Rigs and Sails. A *cutter* is similar to a sloop, but with a movable bowsprit, fitted to rig out or in, jib set flying. Her fore staysail is called a *foresail*.

A *yawl* differs from a cutter in having a small mizzen-mast, stepped close to the stern, with a lug or sprit sail set upon it, the sheet led to the end of a bumpkin projecting astern.

A gaff topsail for a yacht is similar to a coaster's, or it is four-cornered, has the head laced to a yard, and the halliards bent on at a point determined by the shape of the sail.

A *jib topsail* is a light jib set on the topmast stay.

A *balloon jib* is a very large jib of light stuff, extending from the bowsprit end to the topmast head, clew extending well aft.

A *spinnaker* is a light triangular sail, the foot of which is extended by a boom goosenecked to the mast, and rigged out on the side opposite to the main boom, the sail being set on the side opposite to the principal sail on the mast. The halliards lead through a block at the topmast head, the outhaul to the end of the spinnaker boom; the boom itself is fitted with a forward guy from the bowsprit end, an after guy (or brace), and a topping lift.

Some yachts have a light temporary gaff goosenecked at the forward side of the mast-head, about the height of the regular gaff; this gaff is fitted with hoops for the head of the spinnaker, which in this case is a four-cornered sail and is called a *shadow*. It may be set in triangular form by keeping fast the head outhaul. When not in use the shadow gaff hangs up and down the mast by its gooseneck.

Water sails, usually triangular, may be set under the spinnaker boom.

A *ring tail*, usually triangular, is set abaft the main sail, between the gaff and boom-the halliards going to the peak and the sheet to a block at the end of the main boom, or to the end of a spar rigged out on the main boom.

HANDLING VESSELS UNDER STEAM;

OR STEAM AND SAIL.

IN previous chapters we have considered the handling of vessels under sail alone, and with reference to those cruisers whose form and disposition of canvas enable them to manoeuvre under sail like ordinary sailing vessels.

In applying what has been said to steam vessels of war, it must be borne in mind that steamers under canvas never fulfil *all* the conditions looked for in quick working ships. This is partly due to the steamer's form, to a reduced sail area for a given amount of tonnage, to the mode of masting, the drag of the screw, the screw aperture, and other causes.

Vessels of a similar type may differ widely in their qualities under canvas for the same point of sailing, and it would be beyond the scope of a book of reference to enumerate, even for vessels of a single class, peculiarities which are best learned in handling them.

Getting Under Way.-In getting under way under steam, the square sails are not usually set, but the head sails and spanker should be cleared away for assistance in casting. The mast covers should be put on and the mainsail covered, if left bent. Generally the mainsail is unbent and the gear unrove, unless intending to proceed under sail after making an offing. Put on the cover of the main topsail, if used. Reeve off the cat and fish.

Having notified the senior engineer in good time to light or spread fires, when steam is reported ready, call:

UP ANCHOR!

Bring to, unbit, and heave around.

The time required from lighting fires until steam is up may be from one to two hours with anthracite coal. In using bituminous coal with forced draft and other favoring conditions, steam may be raised in much less time.

With good banked fires the time required to spread them and get up steam ought not to exceed twenty minutes.

If a long and heavy heave, give a few turns of the engine now and then slowly to assist the bars. Should the anchor prove difficult to break out, give her a turn ahead, *sending*

word to the navigator to stopper the cable.* When up and down, the ship by moving ahead will certainly trip the anchor, when it may be hove up, catted and fished. The vessel should not "go ahead fast" until the anchor is catted, as it is liable to hook under the fore-foot, and endanger the cat-head.

ONE BELL, signifies to go *Ahead slow*,

TWO BELLS, signifies to go *Stop*.

THREE signifies to go *Back*.

FOUR signifies to go *Ahead fast*. **

As soon as the anchors are secure, pipe down, and set the watch to work clearing up the deck, cleaning the anchors and chains, and paying the latter below.

If the steamer had been riding to an ebb tide you may find some difficulty in turning; if practicable, start ahead, and when clear of everything give a sheer with the helm and run up the jibs to pay her round, or she may be backed astern against the helm, using the jibs and spanker whenever they will be of service.

In a small harbor, or a close berth, a propeller may be turned by putting the helm hard over, when at short stay, and going ahead slowly, the water thrown from the screw having effect on the rudder in the same direction as if the vessel were going ahead.

TURNING AGENCIES IN SCREW STEAMERS.

In single screw ships, the rudder, the screw, the wind and sea, and the pitching of the vessel influence the direction of the ship's head. Each of these factors is variable in the extent of its influence, excepting where the results are due, as cited below, to the shape of the underwater body, or to the shape and size of the rudder.

I. The effect of the rudder depends upon the amount of the rudder angle, size and shape of the rudder, and form of the underwater body of the ship, especially of the run. The rudder effect depends further upon the speed, and finally upon the force and direction of the screw current.

Through the latter conditions, the rudder effect is made to depend upon

* Under recent orders limiting the employment of pilots, the navigator cannot usually be spared to look out for the ground tackle forward. His place there is taken by a watch officer.

All steam vessels would be more effectually managed, when under steam, if provided with a pilot house forward.

** Modifications of these will be found very useful; for example, one bell repeated, means slower; four bells repeated, full speed; two bells repeated, "done with steam" (after anchoring or making sail); and when under banked fires two bells means "spread fires"

II. The effect of the screw, the above being indirect effects of the screw upon the turning. Other effects will be considered at some length further on.

In double screw ships the turning effects, such as they are (in view of the greater distance of the screws from the ship's side and rudder), are made to counterbalance each other by causing the two screws to revolve in opposite ways to drive the ship in a given direction, ahead or astern.

III. The effect of pitching on the ship's head is indirectly through the effect of draft on screw and rudder, and directly through the heel imparted to the ship.

IV. The turning effects of wind and sea are due directly to the pressure they exert on the forward or after body, and indirectly to their influence on the ship's speed and heel.

Each factor, then, affects the ship's head, in part directly, and in part indirectly, in connection with one or more of the other causes mentioned.

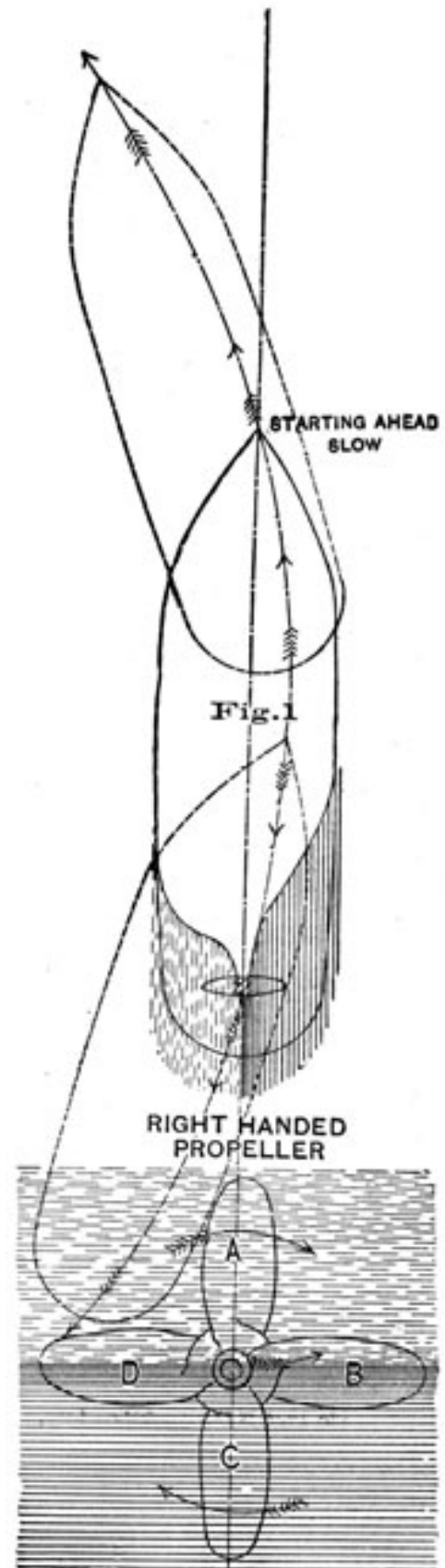
Assuming that there is neither wind nor sea, the features in single screw ships which produce turning effects are the screw and rudder. We shall consider these causes separately, and the effects of the screw in particular.

We note first that the screw may be either right or left-handed.

A right-handed screw is one which, viewed from aft, turns with the sun to drive the ship ahead. This is the screw in common use on American vessels, and is the one discussed throughout this chapter.*

Fig. 1 shows a vessel fitted with a right-handed screw, an elevation of the screw itself being given below the plan of the ship.

* The effects of a left-handed screw are precisely contrary to those of a right-handed screw.



The direct turning effects of the screw are due:

(a.) To the difference in resistance of the water to the upper and lower blades; (b.) To the pressure of the screw current upon the after body when the engine is reversed; (c.) To the lateral pressure of the screw stream upon the rudder-post and rudder when the vessel is going ahead.

(a.) **Difference in Resistance to the Upper and Lower Blades.** When the vessel starts slowly ahead, the water acted upon by the blade A, Fig. 1, presents a certain resistance to that blade. The water acted upon by the ascending blade D is of gradually decreasing density, while the lower blade C works in the most dense and least disturbed medium, and the descending blade B is gradually meeting an increased resistance. The resistance to the lower blades being greater than that experienced by the upper blades, the centre of shaft being the centre of effort, will incline to move in the direction of least resistance (the direction of the upper blades, shown by the arrows, Fig. 1), and as the stern of the ship holds this centre of effort, it must tend in the same direction, to the right (to *starboard*), so that the vessel's bow goes to the left (to *port*).

Moreover, when pushed aside by the lower blade, the denser strata of water experience a speedier inflow than water disturbed by the upper blades; partly owing to the greater density itself and partly on account of the sharper lines of the lower part of the run which permit such quicker inflow. This is an additional reason why the lower blades should experience the greatest resistance, and it therefore increases the tendency of the stern to go to starboard, bow to port.

If the ship is backing, contrary effects obtain, the stern going to *port*, bow to *starboard*, on account of the differences of pressure above described.

The wake current, occasioned by adhesion and friction when the ship is moving ahead, dams up the upper surface of the screw current, checking its motion to the rear. In many vessels, this surface indraught astern is very noticeable when the vessel is going at full speed. Its effect is to increase materially the resistance experienced by the upper blades. The "wake" current, therefore, acts in opposition to the effects due to greater density of the lower water strata.

The resultant of the unequal pressures on the upper and lower blades, and hence that part of the direct turning effect of the screw, depends upon the form and sharpness of the run, the draft, the number of revolutions, and the immersion of the screw.

When the water is just being set in motion, *i.e.*, when

the engine begins to move ahead, the first named cause of turning effect is at its maximum (unequal densities). When the speed increases, the second cause (quicker inflow in the lower strata) attains its maximum, but at the same time the backing up effect of the screw current upon the upper surface of the screw stream increases with great rapidity. Great draft and sharpness in the lower part of the run assist the wake current to equalize the resistance to the upper and lower blades.

(b.) **Effect of Screw Current on After Body in Backing.** When the engine is reversed, the water thrown by the blades moving over to port and downward strikes the lower part of the port side of the run, while the blades which are rising on the starboard side direct their stream against the starboard after body at, or even above the height of the water line. But since at the last named point the screw current, owing to the greater breadth of the ship, strikes at right angles to the vessel, it is therefore of greater effect than the result produced on the other side, where the current from the descending blades impinges, upon the sharp form of the lowest part of the run, and can only exert there a small portion of its strength. Hence, in backing, the screw current tends to push the stern to port, bow to starboard. This increases the effects which we were led to expect under (a) from the difference in densities, and therefore a screw in backing will have a greater effect upon the ship's direction than when the engine is working ahead.

(c.) **Pressure of Screw Current on Rudder-post and Rudder.** When the engine is working ahead, the blade moving to starboard and downward directs its stream against the lower starboard side of the rudder-post and rudder; the blades moving to port and upward, send their stream against the upper port side of the rudder and rudder post. As the rudder is usually broader at the bottom than at the top, and as the stream from the upward moving blades meets with the least resistance and distributes itself with the least effect, it follows that the current from the blades moving downward has greater influence than the stream from the upward moving blades.

The effect will be greater or less, according as the rudder happens to be turned toward the blade moving downward and inward, or toward the blade moving upward and outward.

With the helm amidships, the effect of the screw current on the rudder-post and rudder, ship moving ahead, is to turn the stern to *port*, bow to *starboard*. This effect is therefore opposed to the results due to the moving of the screw blades in media of different density, while it unites with and increases the effects due to the wake current.

The greater the width of the lower half of the rudder in proportion to the upper half, and the more the after portions

of the screw blades incline to the rear, the greater will be the turning effect above noted.

The final resultant of the direct turning effects of the screw will therefore depend in different ships upon the relative importance of the elements above described.

II.-INDIRECT TURNING EFFECTS OF THE SCREW.

These effects are due to the influence of the screw upon the steering powers of the rudder:

(a.) By causing the speed of the ship and consequent way current with its pressure on the rudder; (b.) By causing the pressure of the screw current upon the rudder when the ship is moving ahead; (c.) By suspending the rudder effect when the ship is moving ahead with the engine working astern, the way current being thrust aside by the screw current.

Of the cause and effect in the first case (a), it need only be said that the ship's speed itself is affected in turn by the rudder, speed decreasing as rudder angle increases. There is therefore here, within certain limits, a reciprocal action.

Under (b) may be noted that the screw current increases the effect of the way current on the rudder when the ship is moving ahead. Both screw and way current are strengthened by increase in the number of revolutions.

The effect of the number of revolutions on the turning power of the rudder, as expressed by the time and diameter of turning in a circle, has been investigated with the German corvette "Hertha," with the following results:

In regard to the time of turning.-Change in the number of revolutions with different rudder-angles, had great influence on the time of turning:

RUDDER ANGLE	REVOLUTIONS.					
	66	62	46	30	18	
10°	9.2	9.9	11.5	17.5	37.5	Minutes
20°	6.4	6.8	7.8	12.5	21.5	Minutes

Change in the number of revolutions when the engine is moving slowly is of greater proportionate influence on the time than an equal increase in number of revolutions when moving at great speed.

In regard to the diameter of the circle.-Change in the number of revolutions has but slight effect on the diameter.

The ratio of revolutions to diameters as observed in the "Hertha" at a mean rudder-angle of 20° was as

$$66 : 62 : 46 : 30 : 18 = 1.21 : 1.17 : 1.63 : 0.97 : 1.$$

Hence the time of turning varies inversely as the speed, and the diameter varies directly as the speed. The greater the number of revolutions the less the time and the greater the diameter of the circle.

Under (c) it may be said that in vessels moving ahead the suspension of the regular rudder effect due to a reversal of the engines will be more or less complete according to the relative value of the opposing forces. The screw stream being thrown forward, tends to push aside and away from the rudder the way current coming from forward, due to the ship's onward motion. The regular steering effect of the rudder decreases, while the turning effects of the screw become, in most cases, the controlling force.

Apart from influences due to wind, sea; and pitching; the greater the rudder surface and angle, the less the diameter of the screw, the smaller the number of revolutions, and the sharper the upper immersed part of the run-the greater will be the steering effect of the rudder. Under reverse conditions, the greater will be the turning effect of the screw.

To summarize the results due to the screw alone, we may say

1st. That the screw has its greatest effect upon the ship's head in backing.

2d. That the screw has its least effect upon the ship's direction when going ahead, and that effect decreases as the vessel gathers headway. See also note, p. 544.

3rd. That these effects are greatest when the ship's draft is light, the screw being, however, immersed.

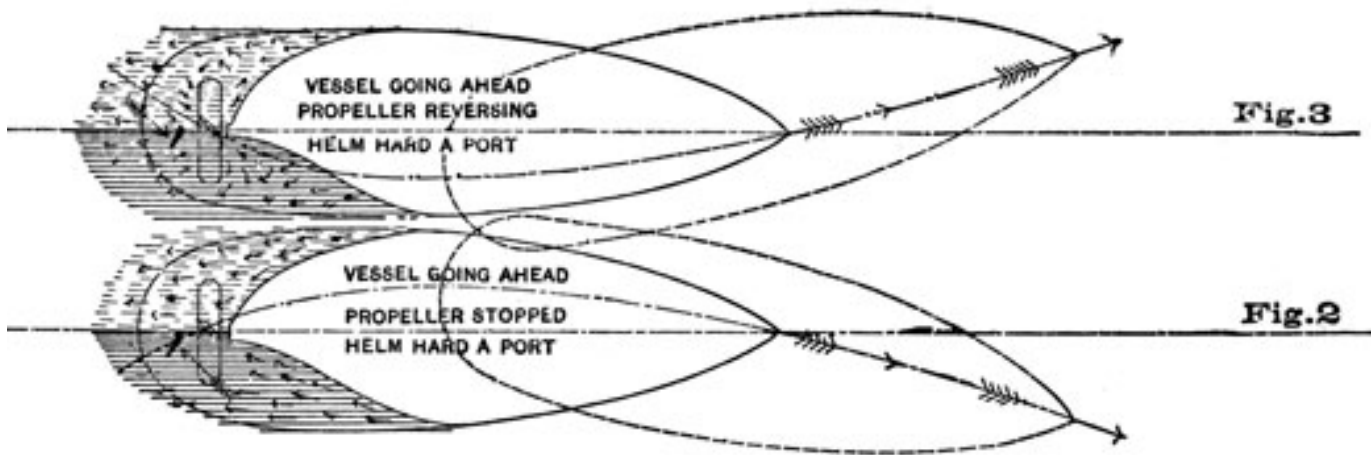
Racing. What is said throughout this chapter of the screw effect presupposes that the screw is properly immersed. If this is not the case the effects may be precisely contrary to those described. No data obtained for a given ship at her normal draft can be relied upon when the vessel is badly out of trim or very light.

Chief-Engineer Isherwood, U. S. Navy, observes that inasmuch as the screw current is due to the slip, its strength and effects will depend entirely upon the amount of said slip.

The same authority points out the increase in the screw current, and its consequent effect on the rudder when the vessel is in very shoal water.

One can scarcely fail to notice the different effect of the screw motion on the wake when in shoal water, as compared with the appearance of the water astern when off soundings.

It is to be noted also that the effect of the screw upon the rudder depends very much upon the distance of the



latter from the former. If, for any special reason of construction, or for the purpose of experiment, the rudder is placed at an unusual distance from the screw, the effects of the screw current on the rudder will be materially diminished.

Turning Effect of the Rudder Alone. The rudder, considered apart from the screw, exercises its usual effect upon the ship's head, the bow turning to starboard with a port helm when going ahead (Fig. 2), and to port with the same helm when making a sternboard, the effect of the rudder being greatest when the ship has headway.

Conclusions. Recorded experiments with the Bellerophon, Lord Warden,* Friedrich der Grosse (See Appendix L), and other vessels of great draft, high speed, and moderate sized rudders, show that such vessels, when moving at full speed ahead, have a tendency to fall off in the opposite direction to that taken when they are just starting or moving slowly ahead. This is due chiefly to increased resistance to the upper blades.

Such vessels, when backing, usually take an immediate and decided sheer, due to the screw effect, but increased perceptibly by a favoring helm. If, while backing, the helm is laid to counteract the screw tendency, it must be done quickly, for when the ship has once taken the sheer due to the screw, she may respond but slowly or not at all to the intended action of the rudder.

In vessels of medium size and speed, sharp in the upper part of the run, and with fair sized rudders, the results to be expected may be expressed in tabular form, as follows:

* In the essay, " Few Years Experience with the Screw Propeller," by A. J. Maginnis-Navy Scientific Papers, No. 12-the writer states, *as a general rule*, that the resistance to the upper blades becomes *greater* than the resistance to the lower blades at high speed, requiring starboard helm to correct the tendency of the screw when going ahead. This extreme deduction is not borne out by any known American data, but it is verified in the case of the deep-draft British iron clad "Lord Warden," which carries at a speed of nine knots one-half to three-quarters of a turn of port helm, her screw being left-handed. (See "Naval Tactics on the Open Sea," by Capt. the Hon. E. R. Fremantle, R. N.)

EFFECT OF RIGHT-HANDED SCREWS ON THE STEERING

OF STEAMERS OF MEDIUM DRAFT AND SPEED.

SHIP MOVING	SCREW WORKING	RESULTS.
AHEAD SLOW, or JUST STARTING	AHEAD SLOW, or JUST STARTING	Screw drives stern to starboard. Ship answers starboard helm quickest.
AHEAD, FULL SPEED	AHEAD, FULL SPEED,	Tendency of stern to starboard decreases, and may disappear. See also foot-note, page 544.
ASTERN, FULL SPEED	ASTERN, FULL SPEED	Screw draws stern to port. Ship answers starboard helm (for stern-board) quickest.
AHEAD	ASTERN, FULL SPEED	(a.) Helm amidships. Screw draws stern to port. (b.) Helm hard-a-port. Ship's stern goes to starboard. stern goes to port quickly, and to a large angle. (c.) Helm hard-a-starboard. ship's
ASTERN	AHEAD, FULL SPEED	Screw drives stern to starboard. Ship answers starboard helm quickest, and as if under headway.

In such right-handed screw ships the port helm may then be called the weak helm, and it is so regarded.

For vessels of medium size, draft, and speed, it seems to be admitted that-

1st. When the screw is reversed, the rudder will act as if the vessel were going astern, *even though she have headway.*

2d. When the screw is going ahead the rudder will act as if the vessel were going ahead, *even though she have sternway.*

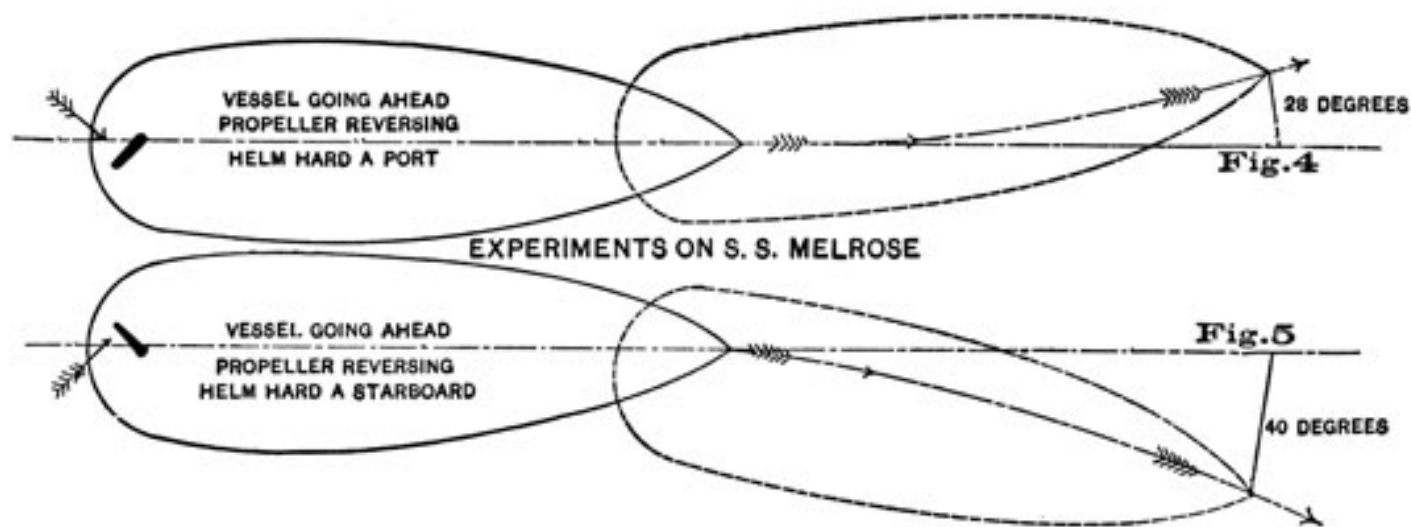
3rd. The faster the vessel is moving in the opposite direction to that in which the screw is acting, the less powerful will be the action of the rudder.

Figs. 2 and 3 are designed to illustrate the reverse effect in the first case; Fig. 2 showing the ship's head affected by the helm alone, Fig. 3 the result of reversing the engines.

Figs. 4 and 5 are from the reports of trials made by Professor Reynolds on the steamer *Melrose* in 1877

and published in the *Engineering*. The ship going ahead full speed, her engine being suddenly reversed and helm put hard a port, the vessel's head turned twenty-eight degrees to port before the ship came to a standstill. Repeating the experiment, but putting the helm a starboard, the ship's head turned forty degrees to starboard before the headway ceased. The courses taken in both cases being directly opposite to that which the rudder would have steered the ship under ordinary circumstances. Compare also Hankow experiments, Appendix L.

35



Comparative Effects of Rudder and Screw. The greatest effect on the ship's head is that of the rudder when the ship is going full speed ahead; next in importance is that of the rudder when the ship is moving at full speed astern. Of the effects produced when the engine is working in one way and the ship moving in the opposite direction, the most important is obtained when the screw is backing. But even at its greatest, the reverse effect of the rudder due to the screw is often feeble, differing in different ships, and even in the same ship, under varied conditions of draft.

Should there be wind and sea, *when a danger has to be avoided*, a ship bringing herself to a standstill by reversal of her engines should be regarded as partly at the mercy of influences which would be easily controlled by the rudder if the ship and screw were moving in the same direction. During the interval before coming to a standstill, screw, rudder, wind, and tide may balance, and the ship move in a straight line till stopped, or any one may pre- dominate, and perhaps cause the ship to fall off in the very opposite direction from that which is desired. *

The "reverse effect" of the rudder as described here, is a general result observed in certain classes of vessels under stated conditions. To rely upon that effect under all circumstances would therefore be as unreasonable as to attempt to tack ship by the same means, whether under double-reefed topsails in a seaway, or under plain sail to royals in smooth water. Details of absolute accuracy for even one type of vessel under varying conditions of wind and weather have yet to be recorded.

Avoiding Dangers. With a right-handed screw great caution should be observed in stopping and backing, to avoid immediate danger ahead and to starboard. When

* The auxiliary steering screw described in the latter part of this chapter is claimed to reduce this "danger interval" to a minimum.

the engine begins to back the bow tends to fall off to starboard, and the helm put hard aport may not counteract this tendency in time to clear the danger. Of course when *moving* astern with sufficient speed the helm should overcome the screw effect, but that may be too late.

If the way is open to port, a quick starboard helm, slowing down if necessary, might be more apt to carry you clear.

Were the danger ahead and to port, by porting, reversing the engine to full speed astern, and quickly shifting the helm to hard a starboard by the time the engine begins to back, screw and helm would combine in their action to carry the ship's head to starboard, and would probably do so sufficiently to avoid the danger.

In passing dangerously close by another ship or other obstacle, remember that when the helm is put over to prevent collision, it is the stern that moves, and that while the bow may be thus saved from touching, the stern may be fouled; but that if the helm be quickly shifted when the bow is *just* clear, the stern will be thrown out. Many a "*touch-and-go shave*" has been thus effected by judgment and nerve. This is a good practical hint, and one worth remembering.

Effect of the Wind and Sea on Steamers. The bow of a screw steamer having no headway, will fall off from the wind. If on an even keel, and the exposed surface is about equal fore and aft, she will lie with the wind abeam. If by the stern she will bring the wind abaft the beam.

If the engines of a screw steamer be reversed when head to wind she will in a short time turn stern to it.

If the engines of a screw steamer be reversed when in the trough of a sea she will, sooner or later, bring her stern to the sea.

Stopping. The distance required by a screw steamer to bring herself to a standstill from full speed, by the reversal of her screw, is said to be between four and six times the vessel's length. The same authority * states that this distance is independent of the power of the vessel's engines, or nearly so, depending upon the size and build of the ship. The statement is probably incomplete. Given two sister ships cruising in company at the full speed of the slowest ship; one vessel having very much better engines than the other, and able to steam several knots faster. If both suddenly reverse and back at their utmost speed, it would seem that the ship which can move the fastest astern will come to a stand sooner than the other.

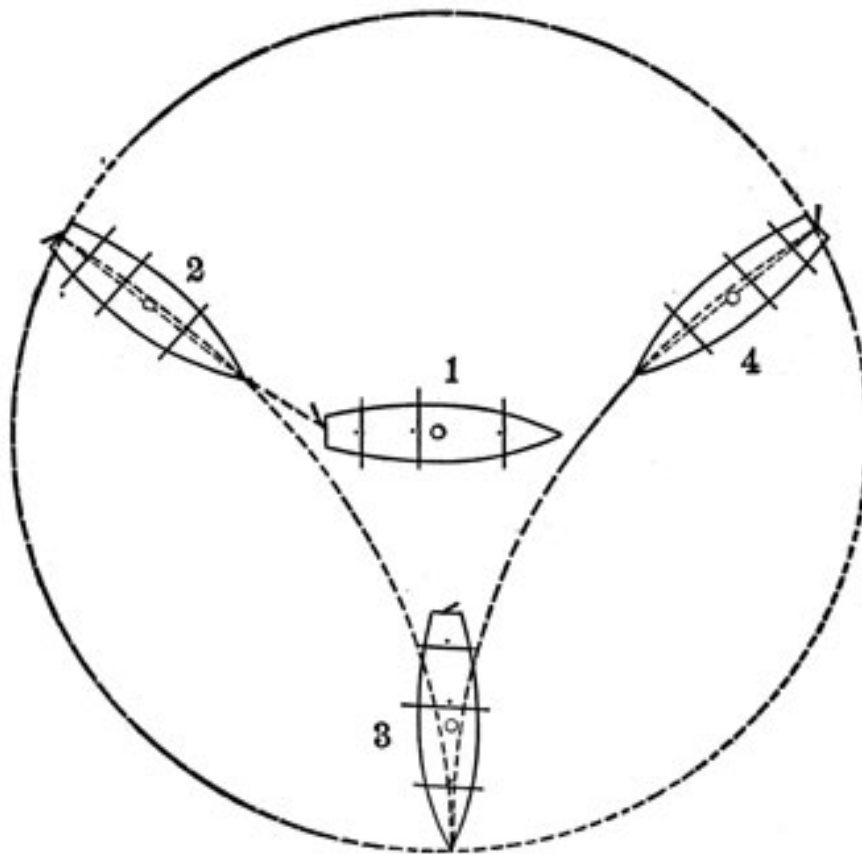
Casting under Steam. An officer knowing

* Report of Professor Osborne Reynolds and the Committee of the British Association "To investigate the effects of propellers on the steering of vessels."

which way his ship tends to turn in backing, takes advantage of that knowledge in paying around to cast, if circumstances permit him to choose the direction of the turn to be made.

To turn in a limited space, put the helm hard a starboard and back on the engine, then hard a port and go ahead, repeating the operation until the turn is completed, as shown in the figure. The bow will swing to starboard, both when going ahead and astern.

It would be very difficult under the above conditions to make the turn *to the left* without the help of sails or dropping an anchor under foot, for the angle gained while going ahead would be, at least partially, lost in backing.



STEAM AND SAIL.*

When a steamer goes ahead fast, the vanes are very deceptive, the wind appearing more ahead than it really is. When in doubt, set the flying-jib as a "wind feeler," steady aft the trysail sheet or haul out the spanker. Should the latter stand well give the order-

Clear away the fore-and-aft sails!

Man the sheets and halliards! and when all ready, *Haul taut!* HOIST AWAY! HAUL AFT! Hoist the jibs taut up and trim down the sheets. Hoist the staysails and trim aft

* One effect of the combination of sail with steam power in propelling a ship, is to increase the efficiency of the screw; for as it then has a part, instead of the whole of the resistance of the water to overcome its slip is diminished.--RANKINE.

the trysail sheets. Care must be taken that the main-topmast-staysail does not catch fire from the smoke stack. Should the wind draw aft you may try the foresail, and if that stands well, get all the canvas on her that will draw to advantage, excepting the mainsail, which, on account of the smoke stack, remains furled, with its cover on, or is unbent.

NOTE.-When making sail on a steamer, the senior engineer should be duly informed with regard to the engine, that he may haul the fires, or bank them, as occasion requires. *Heavy banks* are such that the fires may be spread and steam got up in a little while; *light banks* require more time to get ready.

To Tack a Steamer. Under canvas and steam, should it be required to tack ship, proceed as if under sail alone; if going very fast, slow down before luffing around, otherwise the sails as they fetch aback may bring too great a strain on the fore-and-aft stays. When you "let go and haul," ring to go ahead fast.

To Reduce Sail. If ordered to furl sail and proceed under steam, send down to the engineer to get up steam,* raise the smoke stack and lower the propeller, haul up and furl the mainsail, and put the cover on or unbend it. Fill the fire-buckets aloft. When steam is up, call, SHORTEN SAIL! take in and furl everything, put the covers on and ring to go ahead.

When under steam be particularly cautious not to allow ropes to tow overboard, and in heaving the lead, care must be taken that the line does not foul the propeller. Send the light yards on deck, point the other yards to the wind or brace them sharp up. The topsail yards will soon take against the lee rigging, therefore sway them up about one-third and clap jiggers on the lifts; haul all the rigging taut.

To Make Sail on a Steamer. If ordered to let the steam go down and make sail, send the necessary directions to the engineer, and set all the drawing sail, including the mainsail, as soon as the smoke stack is out of the way.

Weather Helm. A screw ship under canvas is said to carry more weather helm than a sailing vessel, because the water passes along aft, on the lee side, and finding the screw aperture, passes through it; and thus offering less resistance permits the after part of the vessel to sag to leeward, and the forward part to approach the wind, a tendency which the weather helm is called upon to check; furthermore, it is not only the water which actually impinges upon the rudder which turns the ship; the check received by the water from the rudder is communicated to the water before

* Or ring two bells to "spread fires."

it for some distance, and this effect is entirely lost with the narrow stern-post of the screw.

DIFFICULTY OF TACKING A SCREW-SHIP UNDER SAIL.

In tacking, as long as a sailing ship has headway, the water coming along the weather side of the bottom strikes the rudder and assists to turn the ship; but, in a vessel with a screw aperture, the water meets a constant current coming from the lee side through the screw hole caused by the lee way the ship is making, and the side movement of the stern, and is consequently carried off with it at a considerable angle from the line of keel without touching the rudder at all.

In tacking steamers under sail alone, in addition to checking head braces, flowing head sheets, or even hauling down head sails, it is a very common practice to brace around the crossjack yards when the vessel is within a point or two of the wind, before hauling the main yard. The object is to throw the stern in the direction to be taken in paying off on the new tack, and thereby bring the wind on the (new) weather bow. Such counterbracing is of course adopted only when it is taken for granted that the vessel cannot be brought around without a sternboard.

EMERGENCY SIGNAL TO ENGINE-ROOM.

As a rule, when steaming ahead at full speed the signal made to the engine-room, when it is desired to stop the engine, is first to "slow" (one bell), and then to "stop" (two bells).

Similarly when the engine is reversed, to go ahead the signal will be first made to stop (two bells) followed by one bell to go ahead.

In case of an accident, however, the required final signal is made at once, without intermediate signals, and as this should never be done excepting under such circumstances, the very fact of making "stop" from "full speed" constitutes a signal of emergency and it should be obeyed with the least possible delay.

Man Overboard. *Under steam.* Stop and back. Lower boat when in best position to rescue man.

Under steam and sail. Hard down the helm. Stop and back. Take in light sails if necessary, trim yards to assist in backing towards the man; lower boat in best position for rescue.

In both cases, observe the usual precautions about lowering a boat when making sternway.

Heaving to for Sounding, under steam. In moderate depths, slow down or heave to, either head or stern to, as convenient. In great depths, stern to. For description of sounding apparatus supplied for use with reeled piano wire, see Appendix M.

Handling Vessel under Steam and Sail in Squalls. Luff and shake her, or, if too heavy, hard up, brail up spanker, and put her before it, going ahead at full speed,-the steam power in this case enabling the vessel to pay off with the desired rapidity.

Bad Weather under Steam. If in a steamer of sufficient power, heave to head to sea with no sail set, using a sea anchor if desirable. Some steamers, notably long merchant steamers of recent construction, heave to with the wind on the quarter, engines going ahead slowly. But it would be unsafe, probably, for shorter steamers to do so.

A full powered steamer should be able to run before any sea.

Steamers hove to under sail alone, will vary greatly as to the amount of canvas spread and its disposition, but the conditions to be fulfilled are usually the same in all cases, viz.:

First, To show enough canvas, if possible, to ensure steerage way.

Second, To dispose it so as to counteract too great a tendency to fall off.

Modern steamers are often undersparred, so. that any one sail is comparatively small when the immersed longitudinal section is considered. Moreover, the steamer has greater proportionate length than the old fashioned sailing vessel, and a greater tendency to fall off.

The inference is that steamers will heave to under canvas with a greater number of sails and with more *after* sail than a sailing vessel of older model.

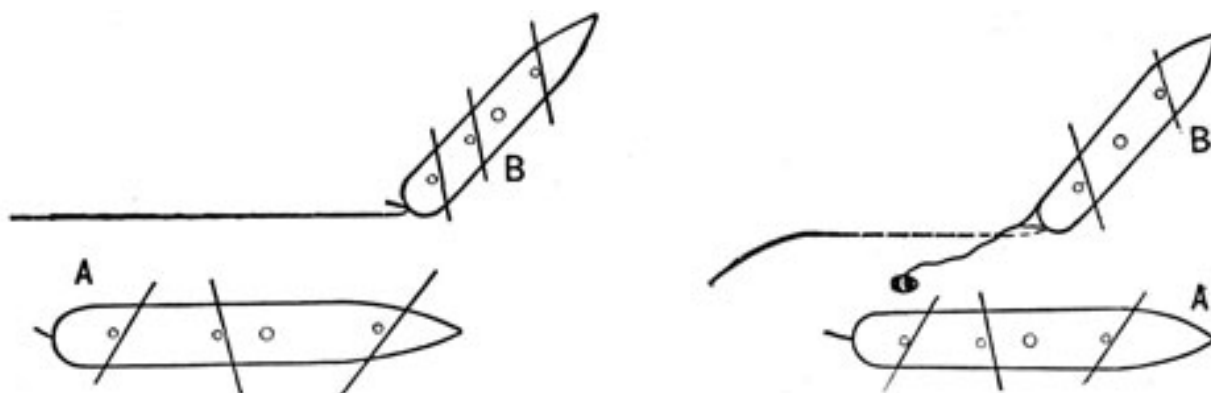
Hence we find many steam men-of-war heaving to under close reefed main topsail, main trysail, and storm mizzen or reefed spanker; the fore storm staysail being bent, but not always set. Others will hold on to the close reefed fore topsail as long as possible, in addition to the above canvas, to ensure the necessary steerage way.

Sending down the light yards and masts, whether under steam or sail, will greatly relieve the ship in heavy weather.

TAKING IN TOW AT SEA.

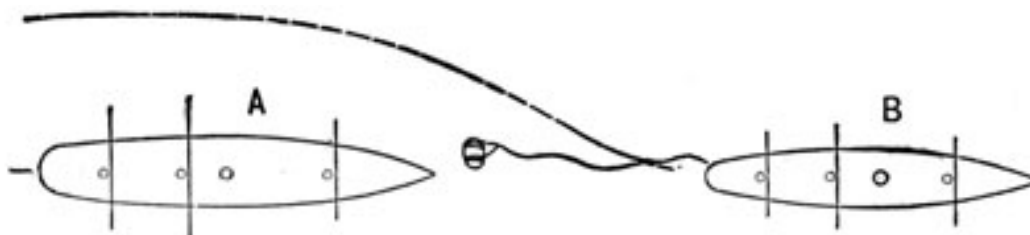
(a) There is a fresh breeze blowing, and A is wholly disabled, or nearly so. B steams along the weather side and throws a heaving line, if prudent, then puts helm hard a starboard, and stops when she can maintain her position

on the bow of A, for some little time. If it be desirable to send a boat with a heaving line she is in a good position for doing so.



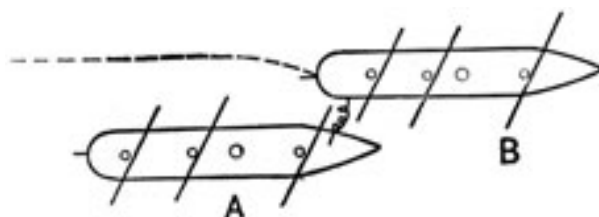
(b) It is blowing a moderate gale. A is totally disabled, and in the trough of the sea. B dare not lower a boat, but slings a water-tight empty cask to the end of the deep sea lead line. She steams up on A's weather quarter at a safe distance, veering or hauling in line to bring the cask alongside of A. B then puts his helm hard a starboard, and holds his position till the towline is fast on board of A.

(c) There is a heavy sea, and A is under control. B



steams ahead at a safe distance, head to wind. A barrel, full of holes, is slung, and the rope paid out until alongside of A. The barrel being full of holes will sink to the water's edge and will not be affected by the wind. A cork fender and grate bar may be used instead of the barrel.

(d) Calm and smooth sea. A is disabled. B steams along her port side and throws a heaving line, puts helm hard a starboard, stops and hauls hawser on board.



(e) In a seaway. A has rudder disabled, but motive power is good. B wishes to help her into port. B takes hawsers from A's quarters. A tows



and B steers. By this disposition, both steamers being large full powered vessels, B can steam at least at half speed, thus relieving A of that much work. If A were being towed, she would take rank sheers at short intervals, obliging B to slow

or stop to prevent parting towlines. Moreover, if B were to tow, A could not use her engines.

If A is a small low powered vessel and B much larger and more powerful, B might tow A with short towlines from both quarters.

Chasing. The chaser will steer a course slightly converging to that steered by the chase; taking the bearing by compass and measuring the angle subtended by the masts. By constantly keeping the chase *on the same compass bearing*, the chaser will attain the chase in the shortest time possible, and by the shortest route.

If the course steered by the chase is more advantageous than that steered by the chaser, the latter can steer a parallel course to take the same advantage, until he arrives as near as possible (that is, abreast of him), and then steer a course to cut him off. Make sail when it will draw.

The vessel chased should employ every means to retard the time of being overtaken. A few cables' lengths more may suffice to save the chase; because a fog, an injury to the chaser, or night coming on, may enable him to escape.

Should the chaser be a sailing vessel, the chase will steam directly to windward. *

Collision. On a collision in steaming, upright the screw. In that case gear dragging overboard will not foul it, otherwise it will.

On a collision taking place when on soundings, it is generally best for the weathermost ship to anchor.

When two ships are becalmed near each other, either send the boats of both to tow the lighter, or of the one that lies in the most favorable position (with reference to swell) for being moved; or else, run warps out from the quarter of one to the bow of the other, or *vice versa*, and both may thus be sprung ahead and steered clear of each other.

To Anchor a Steamer. Ordinarily this is accomplished as follows: Steam in, "slow down" in good time, and, when near the berth determined on, stop the engine; as soon as headway ceases, and she commences going astern, let go the anchor and veer to the proper scope. With an ebb tide, anchor "head on," and the tide will carry the vessel astern fast enough to take her chain. If a flood tide, the vessel should be sheered with the helm, and the anchor dropped so that she may not overrun her chain. When there is not enough wind or tide, reverse the engines, let go the anchor, and back till the required scope is laid out straight.

"Fifteen or twenty minutes before coming to anchor, the chief engineer should be informed of the fact, so

that the fires can be allowed to burn down, and the pressure of steam to fall to such an extent that the necessity of blowing

* For Ship's Papers, see Appendix N.

off is avoided. By this means the great nuisance of blowing off steam is not only obviated, but there is a considerable saving of fuel, the fires being permitted to burn down sufficiently low to supply only the amount of steam required while working the engines by hand, rendering it much easier also on the firemen (whose duties on any occasion are arduous enough), by having a very light instead of a very heavy fire to haul." *

Due notice should also be given before stopping to sound, or stopping for any purpose whatever. The observance of this rule is quite important.

On entering a narrow channel with the flood tide, a steamer could not "round to," but would have to anchor "end on," and swing to the tide; but if waiting for high water, intending to pursue her way up, she would have to anchor by the stern to keep pointed fair.

If after entering a narrow channel a steamer should find herself compelled, by the discovery of heavy batteries, or the appearance of the enemy in superior force, to go out again, the quickest way to wind the vessel would be by dropping and swinging to an anchor; then, as soon as pointed, heave up or slip, making all preparation beforehand.

Should the ebb tide be running, make use of a kedge, and anchor by the stern, giving the vessel a sheer with the helm, that the tide may catch her on the bow and sweep her around. On the flood, let the kedge go from forward to wind her, availing yourself of the helm, jib, spanker, and engine, as circumstances admit.

When ascending rivers where the turns are short, the engine should be slowed down," or stopped, just before coming to a bend, to prevent reaching over to the further shore; and when going up against a strong ebb tide, in such a river, for example, as the Piscataqua, N. H., the engine must be stopped, and should that prove insufficient, an anchor must be let go in the bend to permit the vessel's head to swing to the new course. When pointed right, weigh and stand on. This is an extreme case, however.

Young officers are liable to forget the great use of the jib and spanker in turning a steamer; they are often indispensable.

Mooring to a Buoy. Steam up to moorings slowly, keeping steerage way. If there is no wind, keep the buoy a little on the starboard bow, and when the engines are reversed the bow will fall off, bringing the buoy ahead. ** If the wind is on the port side, the buoy should be brought more off the starboard bow, as she will swing off more rapidly when the engines are reversed.

* Practical Notes on the Steam Engine, by J. W. King, Chief Engineer, U. S. N.

** References are exclusively to right-handed screws.

If the wind is on the starboard side, steam directly for the buoy, if the force of the wind will balance the tendency of the bow to fall off to starboard when the engines are reversed.

If obliged to moor with fair tide or wind directly aft, great care should be taken not to overrun the buoy. A boat should be lowered to carry the warp when the engines are reversed. Do not lower the boat too soon or she may be left astern. For the detail of handling the chain see page 253.

In approaching moorings from to leeward, and with wind and tide so strong as to make it difficult for the boat to pull to windward with a whole warp aboard, the boat may be lowered in good season and given time to reach the buoy. Boat to carry a short towline and a heaving line. Having secured one end of the warp to the buoy and bent the heaving line to the other end, the boat awaits the arrival of the steamer, and at the proper moment pulls for her, tossing the heaving line when within range.

Large steamers frequently find it very difficult to get clear of their moorings in a crowded harbor. When the wind serves, the jib will be of great assistance; otherwise, the slip rope may be veered out as far as practicable and a broad sheer given with the helm or propeller.

The slip rope should be rove from forward aft, and the end secured well abaft the hauling part, so that when cast off it will fall clear. A steamer's bow may be brought back to the buoy under very embarrassing circumstances by the end of the slip rope overriding the hauling part.

If the vessel overrides the buoy and there is a probability of fouling the propeller, the engine should be stopped at once. There will be a possibility of its going clear, and if not, there will be a fair chance of no damage resulting. If the vessel is head to tide, or wind, there is still a chance of clearing when she gets a sternboard in the act of swinging. If this fails, a strong hawser from the bow made fast to the buoy and taken to the capstan would probably clear it, particularly if there were not much tide.

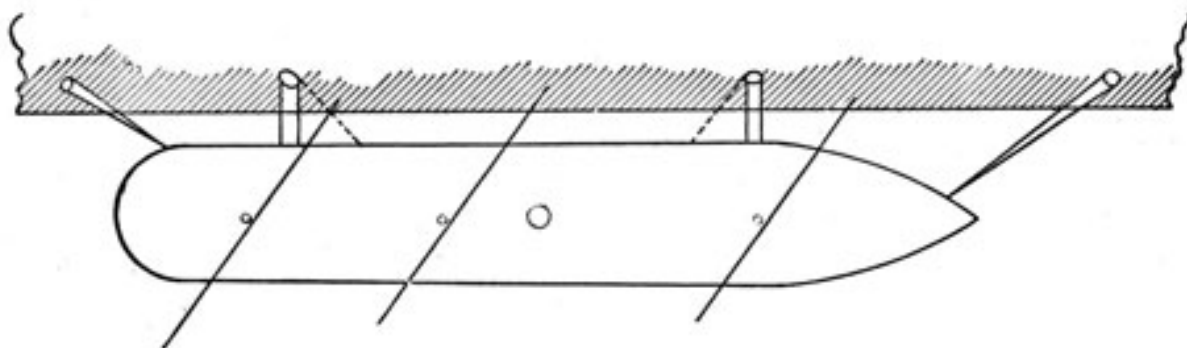
Mooring at a Wharf: To make a successful landing at a wharf it is necessary to know the action of the tide or current. If by chance there should be neither tide, current, nor wind, it becomes a comparatively simple matter.

To moor at a wharf, slack water and calm. There is an advantage in approaching a wharf on the port hand, for if the bow should be pointing too much for the wharf a few turns back on the engine would swing her off, whereas were it on the starboard side the bow would be carried still more towards it. As soon as the wharf is approached, heaving lines are thrown ashore and bow and stern lines run to piles. If the vessel does not come up to the wharf promptly, make the stern line fast and give the engines a turn ahead, taking

in the slack of the bow line. Then back and take in the stern line.

If it is a smooth water berth and clear gangways are desirable, the bow and stern lines may be used as springs and breast lines passed out as shown in the figure.

A wharf should be approached with a head tide when practicable. The bow fast would then be run out and the vessel dropped alongside. If the tide be weak a turn of the screw will assist. The stern fast and springs may then be passed out.



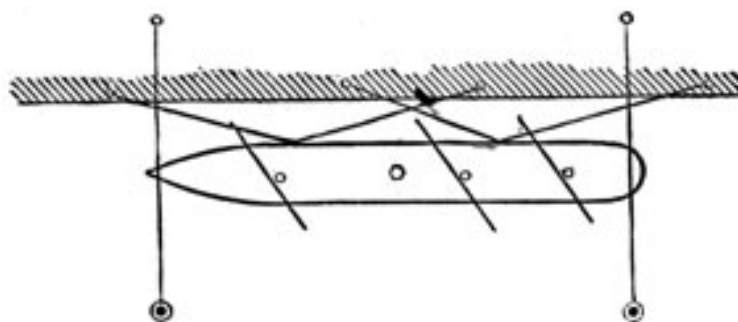
If *there be a fair tide*, the stern fast should be got out first and a turn taken, when the vessel will drop alongside.

If *there be an eddy* setting in the opposite direction to the current it must be allowed for.

The most dangerous eddy is one setting directly toward the wharf. In this case as little drift as practicable should be allowed, as there is danger of bringing up with great force against the wharf.

The most vexatious eddy is that which sets directly out from the wharf. In this case the vessel must reach her position under good headway, the engines be reversed promptly and headway stopped. The fasts must be gotten out as quickly as possible, and the vessel gradually sprung alongside by going ahead and astern alternately and taking in the slack of lines.

When the propeller cannot be worked it is frequently the custom to veer the bow fast well out and haul the stern to the wharf, the bow fast is then hove in by the capstan or windlass and the bow brought to the wharf. It is easiest to get the ship alongside in this way, there being less resistance (owing to the lesser draft) forward, and the capstan is handy for heaving the bow in.



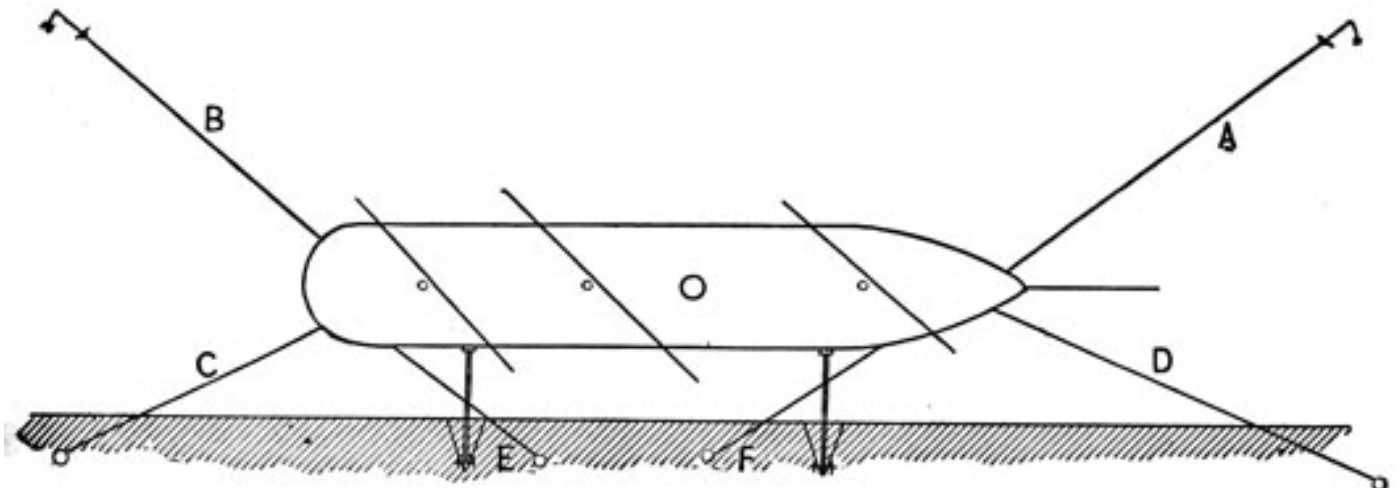
To moor at an exposed wharf, where there is a heavy swell, making it unsafe to lie alongside. In such

cases mooring buoys are commonly placed in position broad off the wharf. Run in between the buoys and the wharf, and run one

warp from the bows to the wharf and one to the corresponding buoy. Hold the vessel in position by means of these and the propeller, and run other fasts. The springs should be double, and run at about equal angles. It will be seen that if the vessel surges on or off ahead or astern she will bring an equal strain on springs and bow and stern fasts.

Hauling in to a wharf from moorings in the stream. A vessel riding to moorings in the stream and wishing to haul alongside the wharf would run a bow warp ashore and make another fast to the mooring buoy. Veer on the latter and walk away with the shore warp. Keep the tide ahead or on the offshore bow by means of the helm. The stern fast should not be run out until near the wharf, and should not be hauled in until the bow is in position, providing there be tide enough to keep her pointed.

Men-of-war having been hauled alongside a Navy Yard wharf generally use the fixed moorings prepared for the berth at which they lie, as shown in the figure.

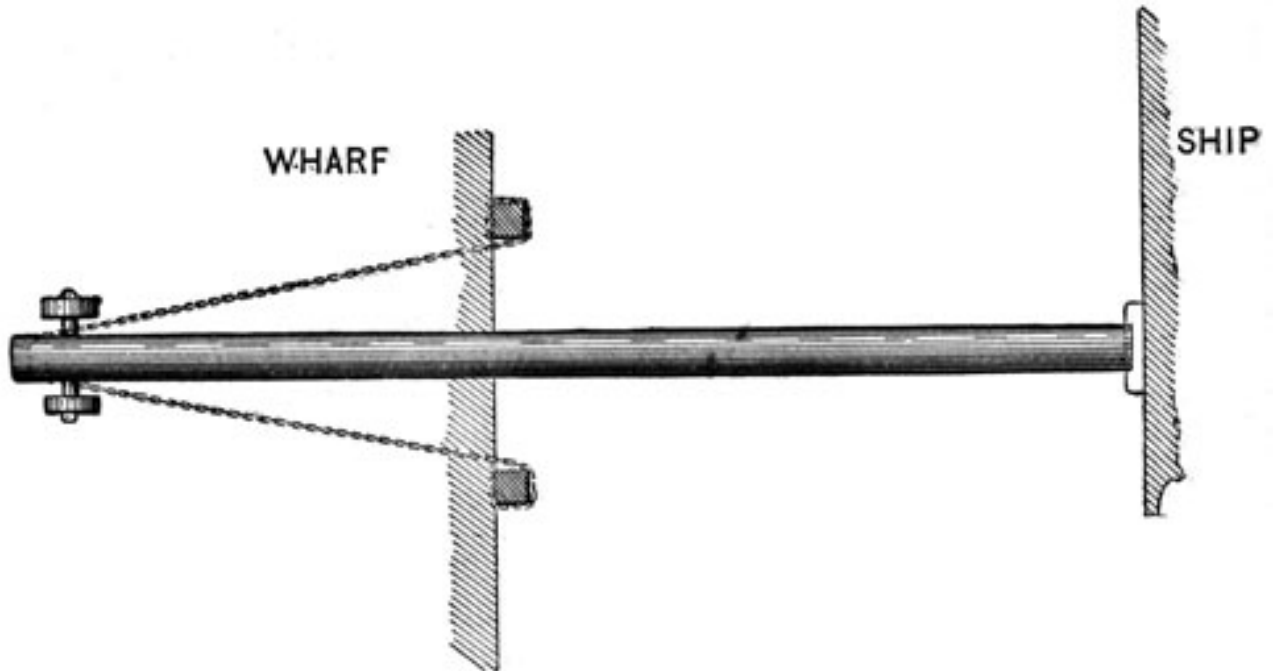


The offshore cable A is taken in through the offshore sheet hawse pipe.

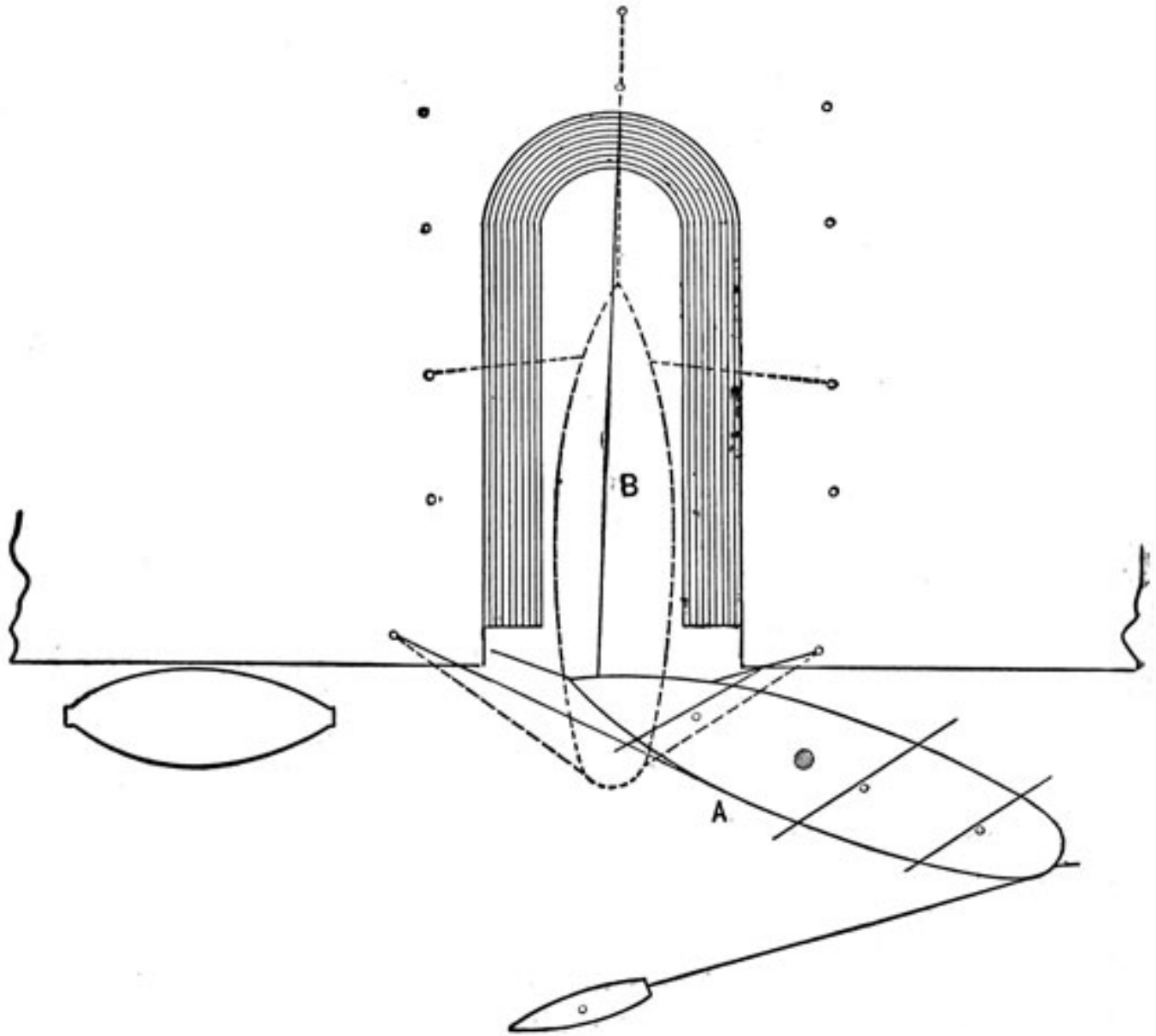
The offshore quarter mooring B is taken to the mooring shackle under the mizzen chains; C and D, the inshore moorings, are similarly secured. There may be also additional breast fasts, as at E and F.

The ship is kept clear of the wharf, which is the side on which the moorings are usually the tautest, by means of spur shores as in the figure. These consist of heavy spars, the inshore end supported on trucks. The outboard end is made to bear against the ship's side by a chain passing through a score in the heel of the shore, or better through the shore itself between the ship and the trucks, so that the chain will not foul the latter. The ends of the chain are secured to piles; a tackle may be clapped on one end of the chain.

The outboard end of the spur shore should take upon a saucer hung from the ship's side. This outer end should



have a bolt on top for a tackle, to hang the shore if the ship is forced from the wharf; also used to haul the spur shore into position. **Hauling into a Dry Dock.** The ship at A has her bow warp run to the head of the dock and

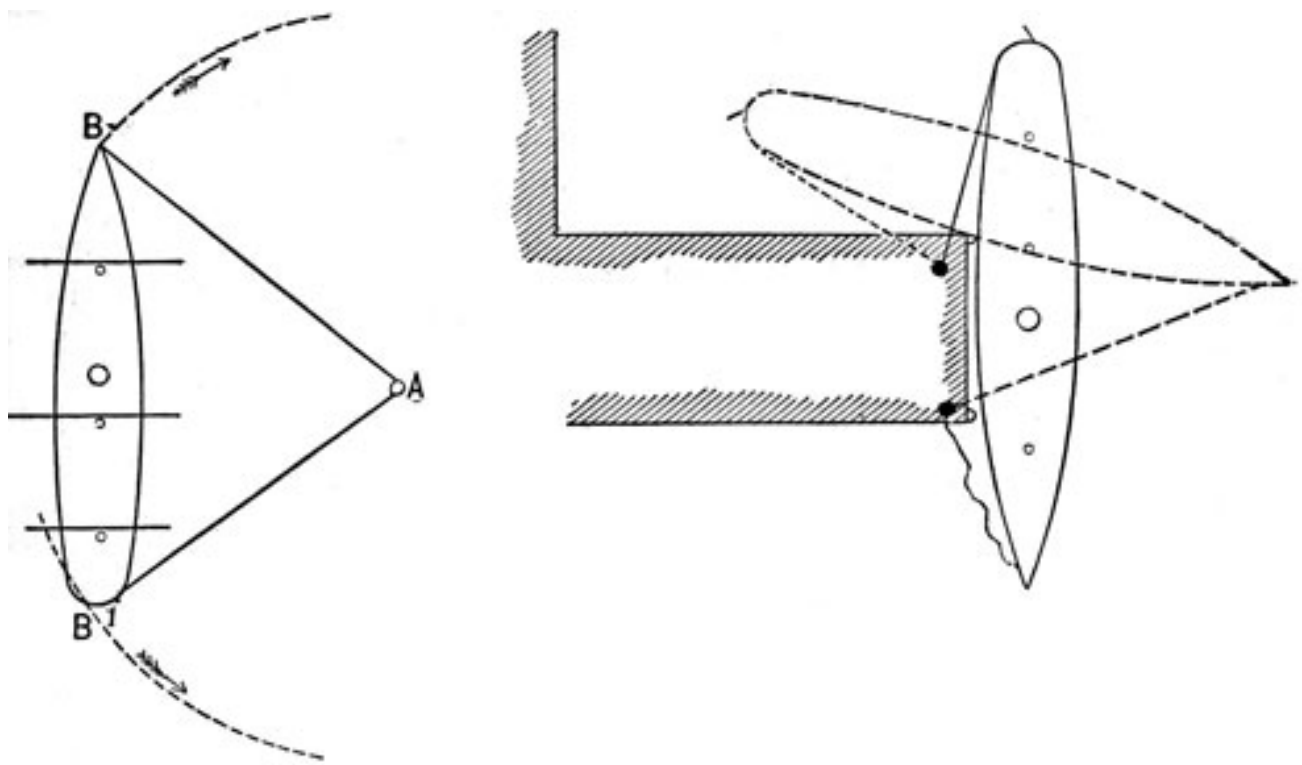


forward breast lines fast to piles. A tug has a line to A's port quarter and is in the act of pointing her. This is done at or near slack water.

At B the ship is nearly in the dock. Her bow warp, with which she is hauling in, is fast to a pile at the head of the dock.

Forward and after breast lines or check lines are fast to piles. The vessel is kept in position by slacking these check lines from time to time. They are passed up the dock from pile to pile as the vessel advances.

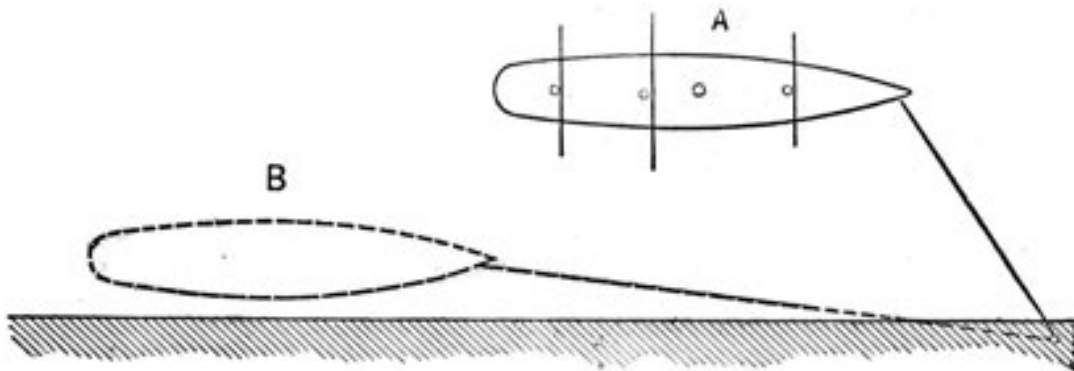
Backing a Vessel into a Slip. Steamboat men acquire great skill in handling their boats about



wharves, by availing themselves of the properties of the spring and the power of the engines. Let A represent a fixed point. By steaming ahead it is evident that the line AB will spring the ship's head around in the direction of the dotted line.

In the same manner, by backing, will AB1 spring her stern around the point A as a centre.

Again, let it be required to back a steamer into a narrow slip. By the use of a quarter spring on starboard quarter, and backing the engines, the ship may be made to turn on her centre as in the above cut. A line from the starboard bow carefully tended prevents her from swinging off too much.



Should it be required to get the ship A to the wharf at B, back the engine, when the starboard bow line will bring the

ship alongside the wharf, and by checking the line handsomely, she may be brought to the berth required.

Taking a Vessel in Tow, in Port. Tugs when towing in strong tideways or crowded harbors always make fast *alongside* the tow, and usually as far aft as possible.

Before the tug comes alongside, make preparations on board the tow by getting out fenders, unshipping gangway ladders, tending braces, running in guns, and topping up boats as may be necessary. Have hands stationed to receive the heaving lines.

The lines used by the tug are the towline proper, or *spring*, from the bow of the tug to the quarter of the tow; the bow line, from the bow of the tug to a point well forward on the tow; also two breast fasts from the bow and quarter of the tug to points directly abreast on the tow. In backing, the bow line has a good lead to give the necessary sternboard to the tow. In giving a rank sheer with the helm, the bow, or quarter, breast fast (as the case may be) will keep the tug in position and prevent her sheering away from the tow.

If the screw of the tug is right-handed, she will make fast to the *port* side of the tow, circumstances permitting.

In this position the tug will make a much straighter sternboard if obliged to back, and in going ahead under port helm (the *weak* helm) she will control the tow more effectually than if on the starboard side.

In towing a vessel of the Trenton class in the East River a tug of the Catalpa size (200 tons) would use an 8-inch spring, 8-inch bow line, and 6-inch breast fasts. The same tug, towing the Galena, would not need larger lines than 6-inch for spring and bow line.

The method of towing alongside is not used at sea, unless in very smooth water. In attacks on fortified places it has been used to great advantage.

If it is desired to tow from ahead, the tow having been notified, will send her hauling lines aboard when you have taken up a position ahead. Steamers have bitts to make fast their tow ropes. The vessel towed will take them either to the bitts or capstan.

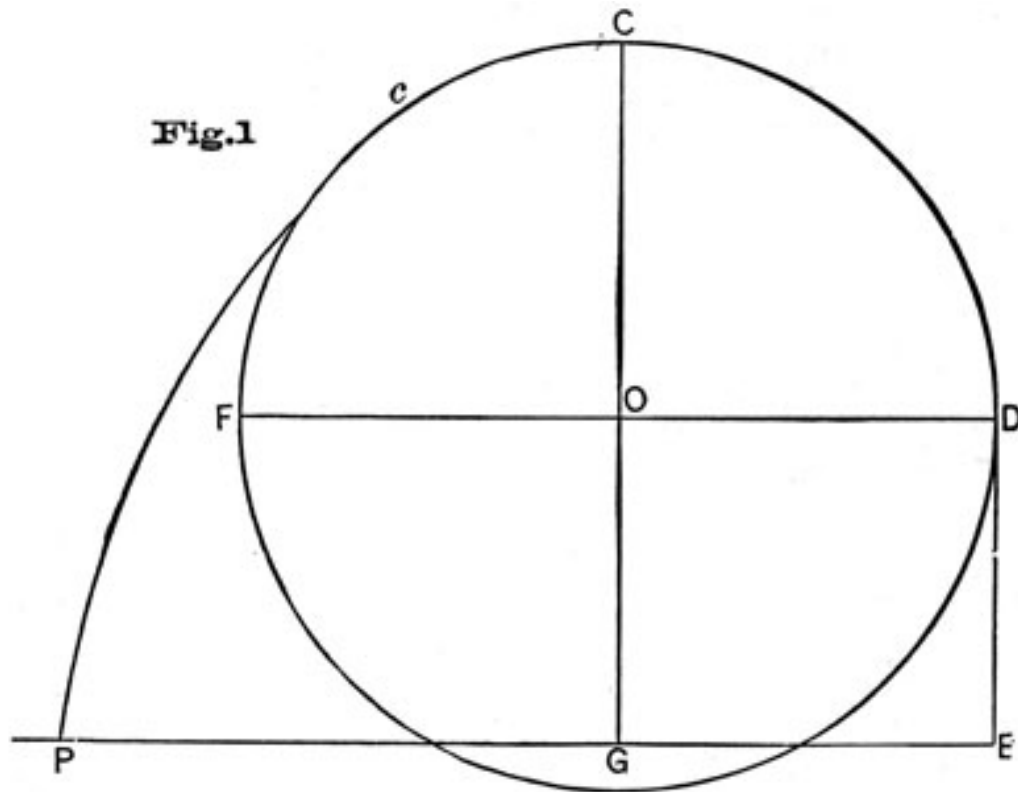
In taking a vessel in tow from an anchorage, the towing steamer may be forced to anchor ahead of the ship to be towed, and the latter will first heave up (the hawsers being secured), and then the towing steamer.

The latter when ahead should use a bridle. The bridle lessens sheering, which might result in carrying away the dolphin striker or head stays.

THE TURNING POWERS OF SHIPS.*

In a calm and in smooth water when a steamer is advancing on a straight course, with uniform speed, the action of a very small disturbing force will deflect her from that course. As soon as the helm is put over and an unbalanced pressure is developed on the rudder the vessel begins to turn.

Her angular motion is gradually accelerated as the helm angle is increased, and after the helm is hard over. After reaching its maximum the angular motion becomes uniform, and thereafter if the helm and revolutions of the engines remain unaltered the vessel continues to swing around through equal angles in equal times. Where there is powerful mechanical steering gear this condition of uniform



circular motion is quickly reached, probably by the time a ship has swung through 360° or even a less angle from the original course.

With manual power at the helm, similar uniformity of angular motion is not obtained until the ship has completed two or more circuits, the longer time in putting the helm over accounting for the difference.

The curve traversed by a steamer in making a complete turn of 360° brings her somewhere within the true circle by a distance varying (other conditions being equal) with the amount of time required in putting the helm over.

In Fig. 1 the vessel has started to turn at P

* From "Lecture on the Turning Powers of Ships," by W. H. White, R. N., and the discussion by Capt. Colomb, R. N., and others of the said lecture. Reprinted from the Journal of the Royal United Service Institution in Navy Scientific Papers, No. 7.

PE is defined as the *tactical diameter*, or the distance between the two positions when the original course is reversed.

At C, when a curve of 90° has been described, of which PG and GC are the coordinates:

GC is the *advance*, or distance that the ship has moved in the direction of her original course.

PG is the *transfer*, or distance that the ship has moved in the direction due to the position of the helm.

Then, if O is the centre of the final circle, FD is the *final diameter*.

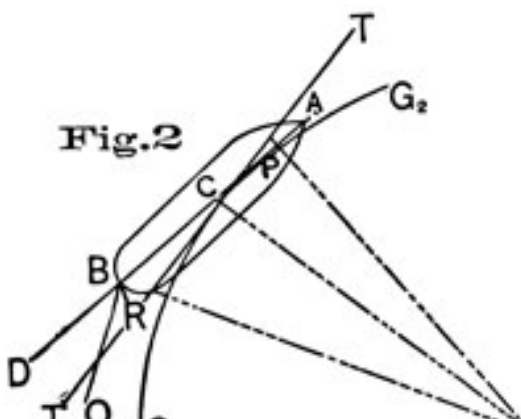
These are the elements of the curve so far as space is concerned, and what should be known for every ship is the advance, and the transfer up to 90° and the tactical diameter. The elements of time required are the time which it takes the ship to go from P to C, and to pass from C to D, and consequently the time from P to D.

The determination of the tactical diameter corresponding to various revolutions of the screw and various helm angles for individual ships is also of value. This is especially true where vessels of different sizes and types are assembled for combined movements under steam. In such a squadron, each vessel must know by experiment the number of revolutions which will give the same speed as a given number of revolutions of the flagship's screw. In like manner, each ship must know the value of her helm angles, relative to the helm angles of the flagship, and of other vessels of the squadron.

Drift Angle. Fig. 1 assumes that when the centre of gravity of a ship has turned through a path of 90° , the line of keel has also altered 90° in direction. But as a matter of fact the centre of gravity will have turned 90° some time before it reaches C.

The drift angle, which represents this difference, is the angle between a tangent to the path of the ship's centre of gravity and the keel line.

As the ship commences her turn, the drift angle will be an increasing quantity until uniform motion is reached.



In Fig. 2 the motion of rotation is assumed to have become uniform. The centre of gravity is then moving in a circle, and the keel line of the ship will make a constant angle with the tangent to that circle.

A represents the bow and B the stern of the ship. C shows the position of the centre of gravity on the keel line AB. O is the centre of the circular path in which C, A and B are moving. T T₁

of the centre of gravity and the angle ACT is the drift angle.

The value of the drift angle varies considerably in different vessels and in the same vessel under different conditions of speed and helm angle. In the Thunderer, for example, with a constant helm angle but with varied speed, the angle was as follows:

SPEED ON STRAIGHT KNOTS	DRIFT ANGLE DEGREES	DIAMETERS OF CIRCLES (FEET).	
		BOW.	STERN.
8.2	5 3/4	1350	1410
9.4	8 3/4	1255	1345
10.4	9 1/4	1240	1340
11.14	9 1/2	1240	1340

The drift angle increases:

- (a.) With increase in speed when the helm angle and rudder area are constant.
- (b.) With rudder area and helm angle, speed being constant.

In any given time the head of the ship must have turned through an angle from the original course which exceeds the angle turned through by the centre of gravity, by a quantity equal to the drift angle.

In Fig. 2, if P is the foot of a perpendicular from the centre O upon the middle line of the ship A B, then to an observer on board, P will appear to be the "pivot point" about which the angular motion of the ship is being performed; for the keel line A B coincides with the tangent to the path of the point P, which is not true of any other point on the keel line. Hence, at P, there is no drift angle.

In the case of the Thunderer, the pivot point P varied from 67 to 103 feet before the centre of gravity, or from 80 to 40 feet from the stern. As the speed and drift angle increased the pivot point moved forward.

To the drift angle is due the loss of speed sustained by a ship in turning. In several cases where this loss has been carefully measured, the speed of advance on the circular path has been only seven or eight tenths of the speed on the straight. The drag of the rudder has little to do with this loss of speed.

Glancing once more at Fig. 2, it will be evident that at each instant while the propelling force is delivered along or parallel to the keel line the actual motion of the vessel in turning is not directly ahead, but sideways.

In fact, the motion bears a considerable resemblance to that of a vessel sailing on a wind, and there is a considerable pressure developed on the side of the bow most distant

from the centre O. This pressure not only checks the speed of the ship, but exercises a decided turning effect, assisting the pressure on the rudder. The importance of this assistance will appear more clearly when it is remembered that owing to the rotary motion of the vessel while turning, the flow of water at the stern is different, even in screw steamers, from that which would take place before the angular motion became marked. In fact, the *effective* helm angle becomes very much reduced from the angle RBD, Fig. 2, which the rudder makes with the keel line AB, produced. We have no exact data for estimating the amount of this reduction, but it approaches to equality with the drift angle for the rudder axis B. If OB is joined, and BQ drawn perpendicular to it, then the effective helm angle, according to this rule, should be taken as approximately equal to RBQ, and not to DBR, or a reduction of at least *one-half* from the angle made with the keel line, even in single-screw ships. Approximately the pressure on the rudder may be expressed as a function of the speed of the ship, and the *sine* of the effective angle of helm; so that the loss of rudder pressure consequent upon such a reduction in the effective angle as is asserted to take place will be very considerable. Apart from exact measures of the reduction, there can be no question as to the fact; and it is one of the matters upon which further experiments might well be made. With the assistance of a dynamometer to register the strains on the tiller end when the helm is first put over, and after the turning motion has become uniform, it would be an easy matter to discover the variations in the effective helm angle if the revolutions of the engines and speed of the ship were also observed.

Heeling. The amount of heeling which accompanies turning is credited generally to the rudder pressure, whereas that effect may in most cases be neglected in comparison with the centrifugal force.

A fair approximation to the angle of heel for a ship in turning is given by the following equation:

$$\sin \theta = 1/32 \times d/m \times v^2/R$$

where:

θ = angle of heel,

v = speed of ship in feet per second,

R = radius of circle turned (in feet),

m "metacentric height"-height of transverse metacentric above centre of gravity,

d distance of centre of gravity above centre of lateral resistance.

In the Thunderer, the centre of lateral resistance was found to be from .43 to .49 of the mean draught below the water line; probably a fair approximation for war ships of

ordinary form would be from .45 to .5 of the mean draught. From the foregoing equation it will be seen that-

The angle of heel varies:

- (1) Directly as the square of the speed of ship;
- (2) Inversely with the metacentric height;
- (3) Inversely with the radius of the circle.

Hence it is obvious that ships of high speed, fitted with steam steering gear, capable of turning on circles of comparatively small diameter, are those in which heeling may be expected to be greatest. Moderate values of the meta-centric height further tend to increase the heeling. If the speed be *doubled*, the angle of heel will be about *quadrupled*, if the radius of the circle turned and the metacentric height remain constant.

It is important to notice, that in taking observations of the angle of heel for a ship in turning, allowance must be made for the effect of the centrifugal force upon the indications of pendulums or clinometers. The error of indication is always in excess, and the correction is very easily made when the diameter of the circle and time of turning have been ascertained.

As the guns of a ship may be laid for simultaneous firing by director when the ship is on a straight course and on an even keel, and fired when the ship is under the influence of her helm, it may be of considerable importance to know what heel is to be expected for a given speed and_ helm angle, to adjust the director and lay the guns accordingly.

Helm Angles. Other things being equal, the rapidity with which a ship turns increases as the time of putting the helm over is diminished, and the diameter of the circle is also influenced. In the case of a British ship, where other conditions were almost unchanged, a steam steering gear was fitted, and the time in putting the helm hard over reduced from ninety seconds to twenty seconds. The time occupied in turning the circle was reduced from eight and one-half minutes to a little over seven minutes, and the diameter of the circle was reduced from 970 yards to 885 yards.

Before steam steering gear became common, equipoise rudders furnished the best means of putting a large rudder area over quickly to a great angle. But now that mechanical appliances are available, ordinary rudders hung at their forward edge are once more preferable, because they are less liable to derangement and more suitable for use in ships having sail as well as steam power,

Other things being equal, the turning effect of a rudder increases with an increase in the helm angle up to 40° or 45° with the keel line.

As illustrating the latter point, Admiral Sir Cowper Key found that the "Delight" gunboat behaved as recorded

in the following table when the helm angle alone was varied:

HELM ANGLE	TIME OF TURNING FULL CIRCLE	DIAMETER OF CIRCLE.
10°	3' 52"	615 feet.
20°	3' 18"	405 "
30°	2' 57"	275 "
40°	2' 47"	205 "

Lieutenant Coumes, of the French navy, gives the following results for the ironclad corvette *Victorieuse*, for an initial speed of about twelve and one-half knots:

HELM ANGLE	TIME OF TURNING FULL CIRCLE	DIAMETER OF CIRCLE.
7°	9' 48"	1,060 meters
14°	6' 50"	933 "
21°	5' 50"	750 "
27°	5' 20"	572 "
32 1/2°	5' 20"	475 "

Commander E. M. Shepard, of the U.S.S. *Enterprise*, reported the following for an initial speed of eight knots, being two-thirds power:

HELM ANGLES	TIME OF TURNING	TACTICAL DIAMETER.
16°	7' 35"	1,624 feet
32°	6' 33"	1,464 "

Tactical and Final Diameters. At present the published information of the ratio of tactical to final diameters is very limited, but for all practical purposes the determination of tactical diameters is the more important.

With manual power and ordinary rudders the tactical diameter for large ships has been found to vary between six and eight times the length of the ships.

For small vessels, where manual power suffices to put the helm over rapidly and the speed is low, the diameter falls to three or five times the length. For very long and swift torpedo boats, with manual power and small angles of helm, the diameter for full speed is as much as twelve times the length, and for half speed about four to six times the

length. With manual power and balanced rudders the diameter for large ships has been reduced to four or five times the length; and nearly equal results have been obtained with ordinary rudders worked by steam or hydraulic steering gear. About three times the length is the minimum diameter ever obtained in large ships turning under the action of their rudders.*

Effect of Twin Screws. Twin screws are now frequently adopted in the most powerful war ships, and their efficiency as propellers recognized. But they have the further advantage of enabling a vessel, by reversing one of her screws while the other drives her ahead, to turn in a very small circle, almost in her own length. The rate of turning is often slow under these circumstances, but the power of giving rotation to a ship practically destitute of headway and with a rudder possibly disabled, is of great value.

With regard to the turning effect of twin screws when working in opposite directions, in deep-draft ships the time occupied in turning is usually greater than the time for turning the circle with both screws working ahead at full speed; whereas for shallow-draft ships the corresponding difference in time is small. For example, in the *Captain*, the time for circle at full speed ahead was five minutes twenty-four seconds; that for circle with screws working in opposite directions, six minutes fifty-two seconds. In the shallow-draft gunboats of the *Medina* class, on the other hand, the full-speed turning trial gave about three minutes six seconds for the circle, and with screws working in opposite directions the time was only three minutes thirteen seconds. It will be obvious that in the shallow-draft ships the ratio of the moment of resistance to rotation to the turning moment of the screws is much less than the corresponding ratio for deep-draft ships.

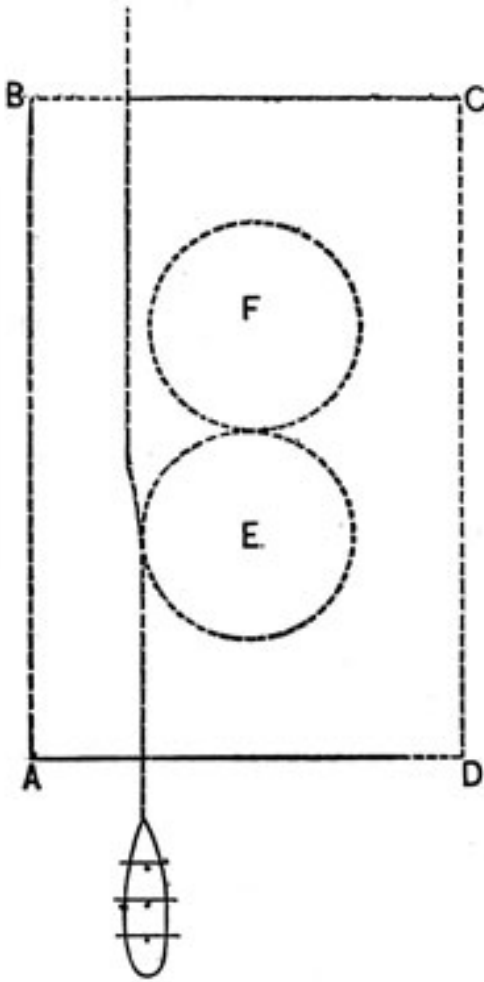
With *ordinary* rudders the use of twin screws does not appear to interfere with the efficient action of the rudder when both screws are working ahead, as compared with that in single-screw ships; experience has shown that equipoise rudders are not desirable features in twin-screw ships. With steam or mechanical steering gear the use of equipoise rudders is, on other grounds, not preferable; so that this feature in the use of twin screws is of comparatively small importance.

Exercises under Steam. Steering trials made during the service of a ship at sea enable officers to gauge the effective performance of their vessels under varied conditions of wind and weather, speed and helm angle. The

* The methods suggested for measuring the diameters of circles will be found in Appendix L, together with the results obtained for the "*Tennessee*," "*Quinnebaug*," and "*Enterprise*."

value of such knowledge cannot be over-estimated. On the subject of turning trials an eminent authority * is quoted as saying that a table of turning powers is no less necessary to a ram than a range table to a gun. But exercises in manoeuvring should not be confined to the describing of circles and determining of tactical diameters. In the Mediterranean squadron under Lord Clarence Paget, R. N., the vessels were exercised on convenient occasions in performing a figure of 8 evolution. This was done by placing buoys as shown in the diagram, and under the following conditions, viz.:

A, B, C, D, are four buoys placed in the form of a parallelogram, of which the long side will be approximately four and one-half times, and the short side three times, the length of the ship.



E, F are two buoys placed one length and a half of the ship apart, and at even distances from the centre of the parallelogram. The ship is to enter the parallelogram, either between B and D or between A and C, the exact time of her stern passing the dotted line between the two buoys being noted; she is then to perform a figure of 8 within the parallelogram by crossing, each time between the points E and F, as shown in the diagram, and she will then come out at the opposite end of the parallelogram from that at which she entered, the precise moment of her stern passing between the buoys on leaving the parallelogram being also noted.

No ship is to use more than half-boiler power, but she may aid herself in any manner by the use of sails or otherwise, as may be deemed expedient.

When once the ship is within the parallelogram, if any part of her should touch the dotted straight lines between the buoys, she will be supposed to have grounded, or should she touch either of the buoys E, F, she will be supposed to have fouled the ships which they are intended to represent. In either of these cases the manoeuvre must be presumed to have failed. The direction and force of the wind, the state of the sea, and the direction and strength of the current (if any) are to

be noted during the experiment.

* Captain (now Admiral) Bourgois, French navy

As to the results, the author of the pamphlet from which this description is taken,* states the following:

"This exercise had the effect of teaching the officers what were the steering capabilities of their ships, not only whilst going ahead, but when moving astern; and I may add that after we had made the experiment twice, in which I am bound to say we did not quite succeed, I had much greater confidence in managing the vessel when moving in or out of confined harbors, or in close order with the squadron. Such practice as this must prove useful, and cannot fail to instil valuable instruction regarding the steering properties of a vessel, not only for the benefit of her commander, but also of the lieutenants and master."

One may be enabled, by practice of this kind, to tell, within a few yards, where any ordinary combination of tide, wind, and rudder will place the vessel. With readiness of resource and good judgment, an officer applying such knowledge in action is likely to prove a dangerous antagonist.

STEAM STEERING GEAR.

The importance of the use of steam as a motor for steering ships was recognized many years ago. At that time practical men noticed the idea only with derision, but of late years its application has been common in the merchant marine and in foreign navies. Its introduction on board our cruisers is recent. One form adopted in the service is that invented by Mr. Sickels, the designer also of the "Trenton" windlass, previously described.

Plate 124 shows the general form of the Sickels' steam steering; the particular design being that adopted for the U.S.S. "Lancaster."

The engines AA consist of two cylinders of the half trunk variety, placed at an angle of 90° to each other and acting on the same crank pin; the shaft is above the cylinders, and the frames are cast on.

The valves are of the kind known as piston valves, steam being admitted in the middle and exhausted at the ends and through the valves. These valves are made with excessive lap on the steam side, and have a triangular score cut in them, by which means steam is admitted, at first, the object being to avoid the jerking motion which would result from a sudden, free admission.

There is also a negative lap on the exhaust side for the purpose of readily freeing the cylinders of water.

Upon one end of the crank shaft is secured a deeply grooved conical *drum* D, for the reception of the tiller ropes.

* Admiral E. A. Inglefield, R. N. "Recent Experimental Cruising," &c.

This drum is so constructed that when the helm is hard over the relative leverage is double or treble that when it is amidships, thus increasing the leverage where the resistance is greatest. The cone is also so proportioned as to get the same effect, as regards uniform tightness of ropes, as a quadrant or sliding block on the tiller would give.

On the opposite end of the shaft is a *brake wheel*, W, secured by a key and set screw.

The brake is a wrought iron hoop which embraces three-fourths of the circumference of this brake wheel; it is lined with a strip of red cedar and is held in place by adjustable springs in the brake fastenings, S, S. The use of this brake is to steady the operation of the machine.

In the brake wheel on the side farthest from the drum is inserted a pin fitting snugly, but free to move, and held in place by a key on the opposite side. This pin is forged on an arm, at the other end of which is forged another pin, to which are connected the valve stems. The last pin has a cam yoke, the yoke, pins, and arm being in one forging.

When the valves of the engine are in a neutral position, the pin on the arm, which operates them, has its centre coincident with that of the crank shaft.,

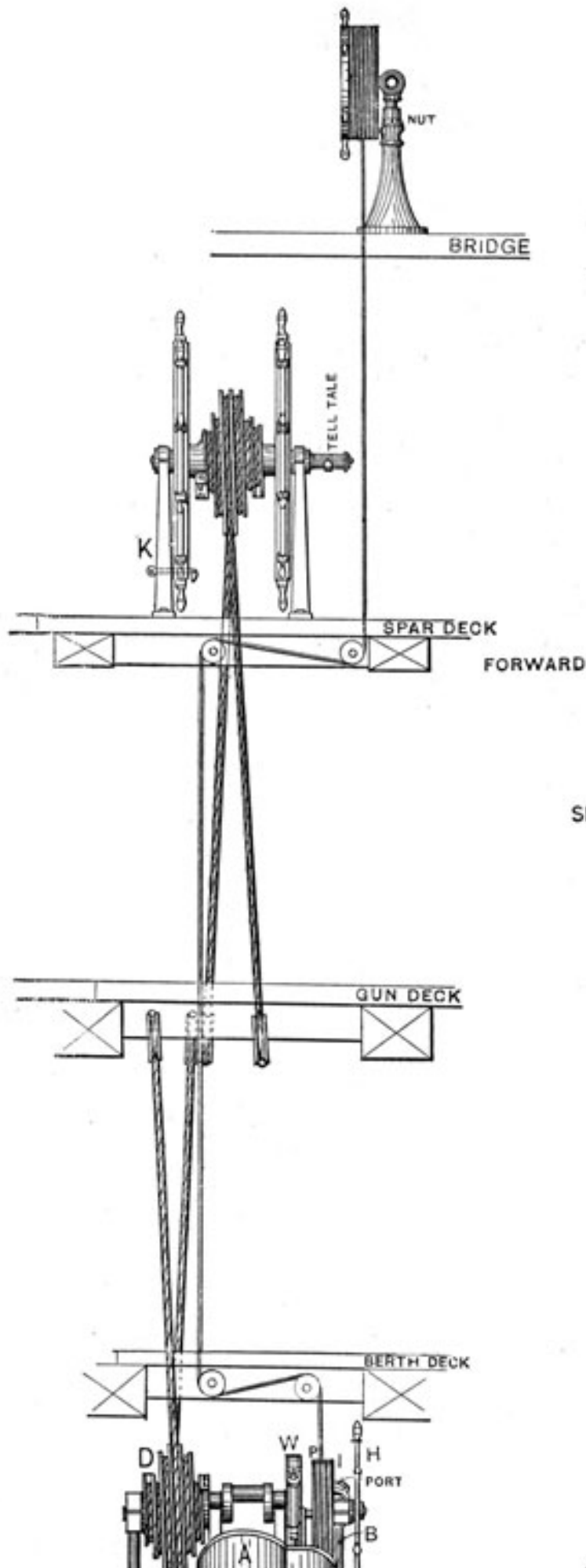
In the same centre line as the main shaft is a small shaft, supported in a bearing B; the centre of this bearing is enlarged by a collar on which is cut a thread which operates an indicator I, for the purpose of showing the position of the tiller. On the end of this small shaft nearest to the crank shaft is forged a disk; to the after side of this disk is secured a cam which fits neatly into the cam yoke. The cam is of brass, with steel shod points and sufficient eccentricity to actuate the valves.

The disk has also attached to it a pulley of brass, P, with a grooved thread on it, designed to carry the cord from a similar pulley on the hand wheel, intended for steering, placed on the upper deck, bridge, or elsewhere.

The forward end of this independent shaft has a hand wheel, H, secured to the shaft by a set screw. This gives an apparatus for steering, situated with the engine, &c., entirely below the water line.

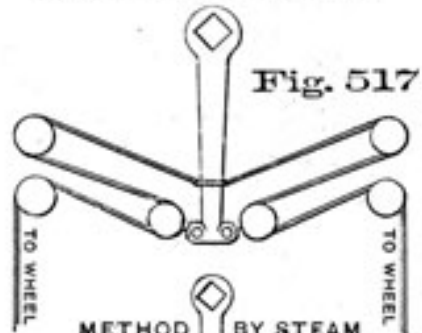
To operate the machine the hand wheel is moved in either direction desired, thus changing the position of the cam, which in turn changes that of the yoke and pin on the loose arm, thereby operating the valves and causing the engines to revolve their shaft in the same direction as that given to the hand wheel.

The hand wheel having ceased its motion and being independent of the engines, as soon as the latter move the crank shaft and drum through an equal distance, it has brought both shafts to the same relative positions as at starting, and consequently closed the steam valves. The engine shaft, therefore, follows in direction and moves



USUAL METHOD BY HAND

Fig. 517



METHOD BY STEAM AND HAND

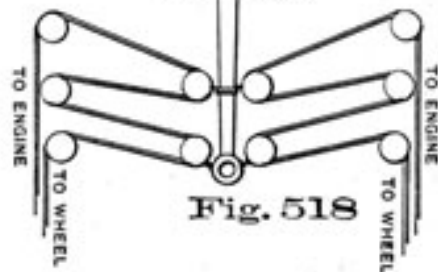
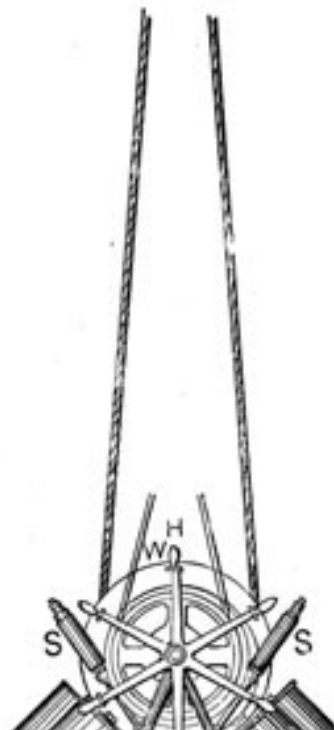
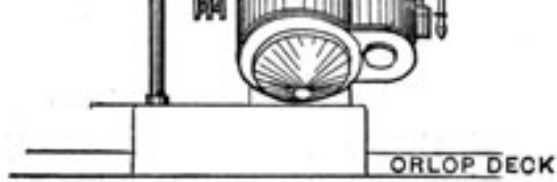


Fig. 518

SICKEL'S STEAM STEERING ENGINE AS APPLIED TO U.S.S. LANCASTER.





through the same angle as the hand wheel shaft, and stopping the motion of the latter, stops that of the former.

The steering wheel for the upper deck is usually a small brass wheel, V, mounted on a frame in such a manner as to be capable of an adjustment vertically of several inches, for the purpose of tightening up the steering cord, which is wound in a suitable groove cut upon its face.

A thread on the shaft, cut with a pitch corresponding to the cord grooves in the pulley, allows the wheel a certain amount of fore-and-aft motion. This furnishes a tell-tale to ascertain the position of the tiller and keeps the steering cord constantly in a vertical position over its hole in the deck, obviating the use of the slot cut for ordinary steering ropes.

When there is no steam on, the steering wheel might be moved so far over as to reverse the position of the cam and make the engine work the tiller, when steam is introduced, in a direction opposite to that intended:

Stops have therefore been provided to prevent the cam from being thrown too far either way. These stops consist of pins on either side working against spiral springs inserted on the sides of the yoke, against which corresponding stops on the cord pulley strike.

Below the cord pulley on the cam shaft, is situated a brass piece sliding on a wrought iron guide, carrying on its upper side a tooth which fits into the grooved thread of the pulley. By this tooth the slide follows the groove until it brings up against a stop held by a heavy steel spring. The object is to prevent the hand wheel being moved beyond the distance necessary to put the helm hard over either way.

Any shocks to the helm resulting from the force of the waves against the rudder, or from striking ice, wreckage, &c., are taken up by the cushion of the steam against the cylinder pistons. Hence, when using this steering gear, there is no possibility of the wheel's taking charge in spite of the helmsmen, as sometimes occurs with the hand apparatus.

This apparatus is at all times ready for use when steam is raised, for, from the peculiar arrangement of the valves it is not necessary to first free the machine from condensed water to prepare it for service as is necessary in an ordinary steam engine.

Steam and hand power steering. An important point with any steam steering apparatus is the ability to connect or disconnect it quickly, so that the use of the ordinary hand wheel may be substituted for the steam steering gear or *vice versa*. To effect this with the Sickel's patent the wheel ropes are rove off *on the bight*. Instead of securing the ends to the tiller as usual (Fig. 517), they are passed over sheaves and

steam apparatus (Fig. 518). All that is necessary in wishing to use either method of steering is to *lock the other* in its midship position, and the ends of the tiller rope on the locked apparatus become the standing parts. This locking is instantly accomplished by pushing a pin K through a hole in the wheel, or a flange, thus securing it to some stationary object sufficiently to prevent its turning. Figs. 517 and 518 show the lead of the wheel ropes from the tiller.

The above described apparatus differs essentially from the forms observed on board foreign vessels. In these the machines work with gears or worm wheels, and instead of acting upon the valves by the hand motion, have them driven by eccentrics as in ordinary engines. A supplemental valve is commonly attached with its ports so arranged that when worked by hand, steam is admitted to the centre or ends of the main valve, according to the direction of the revolution required, an arrangement similar to the reversing valve for the Trenton's windlass. The steerer above described is necessarily quicker in action, and is, moreover, noiseless.

Manton's Steering Apparatus (Plate 125). This machine, as supplied to the Miantonomoh for trial, consists of a pair of horizontal engines working into larger gear. Upon these shafts are worms, running into a gear upon the rudder head, as shown in the figure. The valve motion is similar to that of the foreign machines above referred to.

On board the Miantonomoh the valve stem is attached to a screw actuated by a nut connected to a small grooved pulley. This nut is held horizontally by an attachment to the rudder head. The pulley, can give it a rotary motion, and as it is held from advancing or receding by the tiller attachment, the valve is moved through a distance corresponding to the pitch of the thread. In the pilot house is a larger grooved wheel on the same shaft with an ordinary hand wheel.

To work the machine. By revolving the wheel in the pilot house the pulley at the engine is turned, thereby turning the nut and drawing or thrusting the valve. This gives steam to the engines and they will continue to work till the steam is cut off by the reversing (supplemental) valve being put in its neutral position again by the automatic attachment on rudder head readjusting the nut. On the worm shafts on each end of the worms are rubber buffers, or springs, to relieve the gearing from shock of the sea.

With this form of steering gear the wheel ropes for a hand wheel cannot be left connected with the tiller, for if they were the hand steering wheel would revolve with every stroke of the engines when operating the rudder by steam.

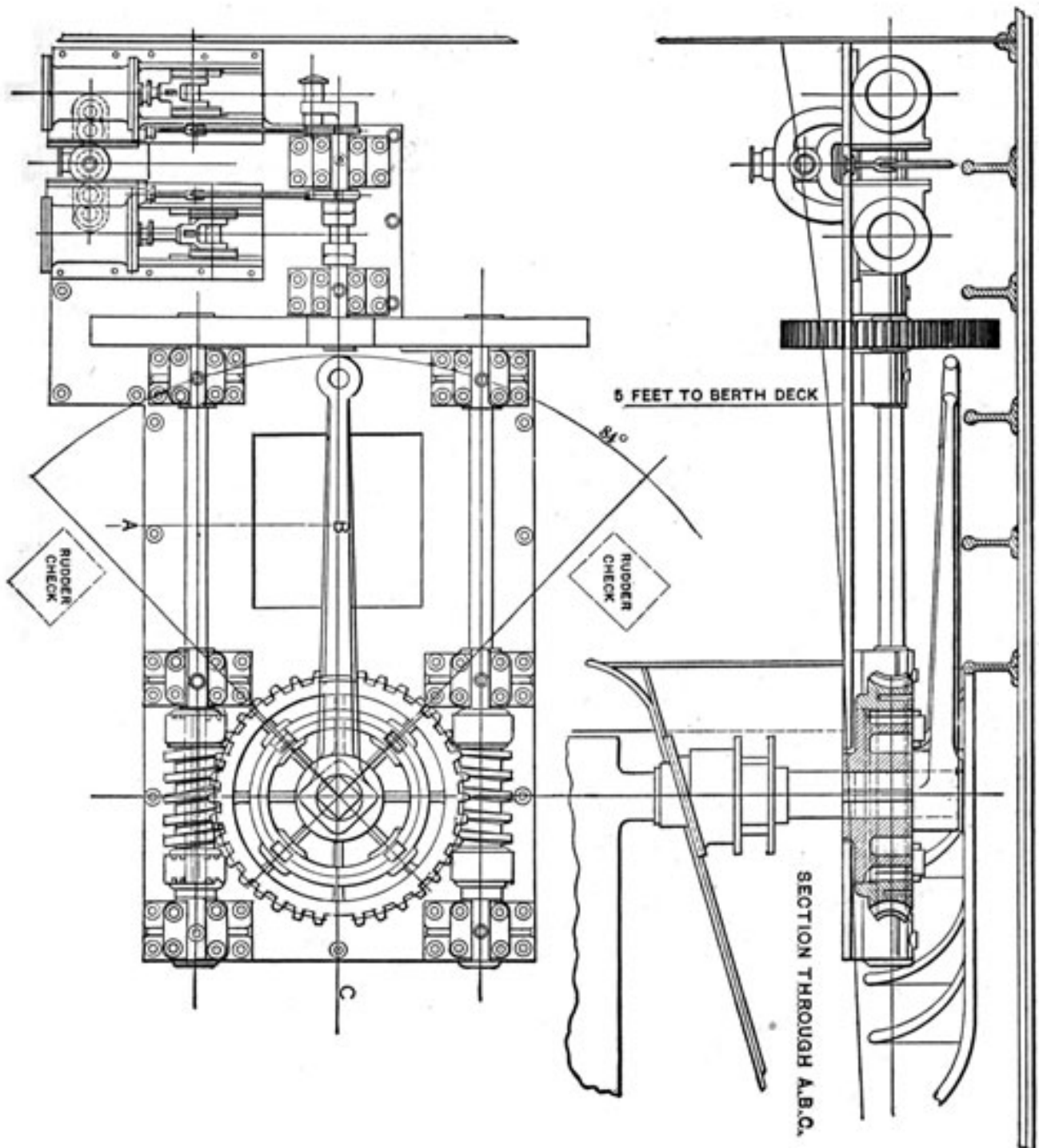
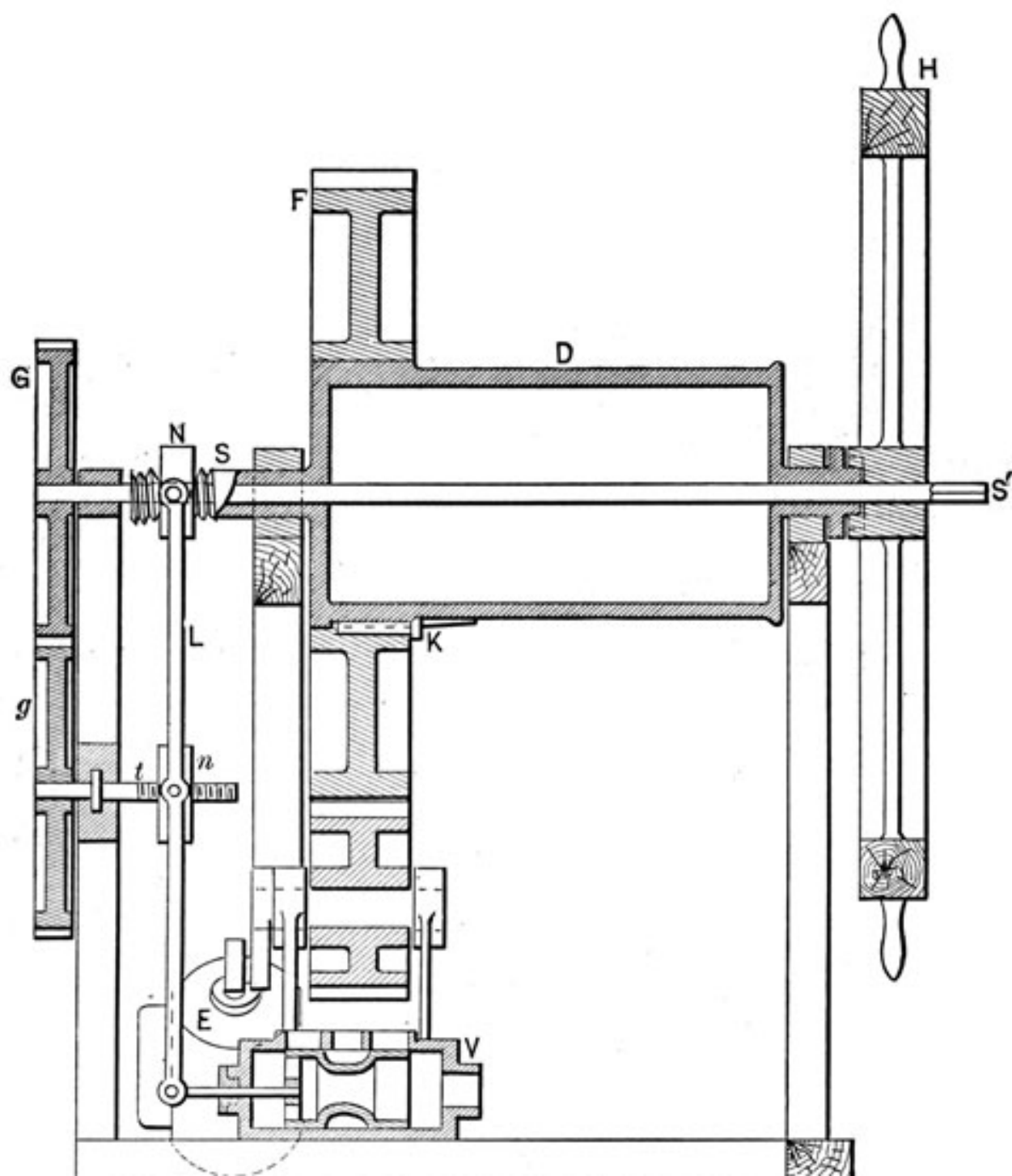


Plate 126



Baird's Steering Apparatus. Plate 126 shows this form of apparatus, of which the inventor, Passed. Assistant Engineer G. W. Baird, U.S.N., has kindly furnished the following description:

"The wheel H is used to steer by hand when coupled to the drum D as shown, but if slipped forward on the line of its axis it disengages from its clutch and sliding upon the square end of the shaft S', engages the steam gear only. When steering by steam, any motion given to the shaft S' is transmitted to the valve V through the intervention of the gears G and g, the shaft t, nut n, and lever L.

The valve V admits steam (or compressed air) to the engine E, which starts the drum in motion through geared wheels; but the drum D, which is prolonged into a threaded shaft S revolving within the nut N moves the lever L in a direction to shut the valve V and stop the engine. The arms of the lever and pitches of the screws are so proportioned as to cause the drum D to complete the same angular movement that has been applied to the wheel and to stop then automatically."

This form of apparatus has advantages in the small number of parts, simplicity and accessibility for repairs.

The Value of Steam Steering Gear. In discussing the turning power of ships, attention has been drawn to the question of *time* occupied in putting the helm over, as a component of the resistance to quick turning. The time so occupied depends directly upon the efficiency of the steering gear.

On board the monitor Roanoke, with the usual hand gear it took two men two minutes to move the rudder from one extreme position to the other and required 19 turns of the wheel. With the steam steerer one man could easily move the helm from hard a port to hard a starboard in 5 seconds with 3 1/2 revolutions of the wheel.

The power which such a machine must exert to put a rudder over to 40° has been found by trial (Napier's experiments) to be equal in statical moment to the product of the following factors:

- Area of rudder in square feet;
- Distance of centre of that area from axis of rotation;
- Square of speed of advance of screw in knots;
- Constant 0.94.

Power in excess of the demand is of course necessary, the amount depending on the tonnage and the nature of the service, but no possible defect lies in the direction of too much helm power.

An ordinary rudder, moved by hand, might answer for cruising purposes, and yet be insufficient for rapid manoeuvres in action. But by introducing steam steerers we are able to provide and manage much larger rudders than could possibly be operated by hand.

Auxiliary Steering Screws. This method of increasing the handiness of vessels has been proposed by a Hungarian engineer.* The feature of the plan is a secondary screw (as shown in the diagrams) which is connected by an universal joint, of simple construction, to a projection of the main shaft. The joint consists of two steel double-eyed forks; between these forks is inserted a block of phosphor bronze. Into the block screw four pins, coupling the forks to the block, and to each other. A locking pin is then screwed into the block and takes in a groove, concave in form, cut out of the inside ends of the other four pins, which keeps them from working loose. Any form of steam steerer may be used with this apparatus, to insure quick handling of the helm.

The auxiliary screw may be mounted on the after-part of the rudder, as *in* Fig. 519, Plate 127, or in the rudder, as in Fig. 520. Figs. 521 and 522 show the universal joint, P being the locking pin and A, B, C, D the coupling pins.

By making the secondary screw of coarser pitch than the main propeller, a certain increase of speed has been obtained, assumed to be due to the action of the smaller screw in picking up the slip of the larger.

The apparatus is being fitted for trial to the U. S. tug "Nina."

Vessels which do much of their cruising under canvas, will find disadvantage in the increased drag due to the additional screw. This is probably offset by the value of the second screw to the same vessel when under steam alone. Tables given in Appendix L illustrate the performance of the steamer "Stratheden" (2,000 tons), with and without the attachment.

The most important advantage claimed for this apparatus is its immediate effect upon the ship's head. As soon as the helm is moved, a decided turning effect commences, whether the engines are reversed or continued running in the same direction.

Whether improvement is to be in the direction of twin screws, steam steerers, or other agencies, it is certain that, handiness must increase greatly in modern men-of-war, if the ram and torpedo are to be elements in naval warfare. To profit to the fullest extent by such improvements, experience in handling vessels under steam alone must be an essential part of a young officer's education.

It would be idle to deny the existence of a prejudice against the discussion of many questions which relate to manoeuvres under steam. Nor is such prejudice confined to our own service.

* Mr. J. J. Kunstädter.

Fig. 519

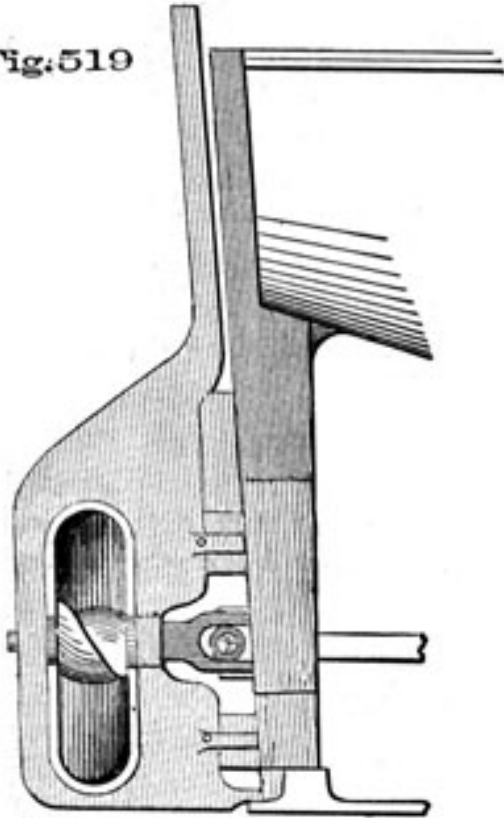


Fig. 521

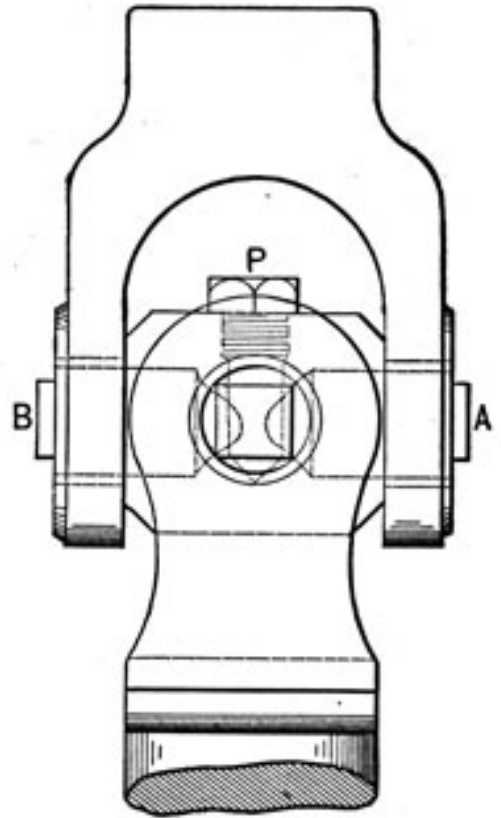


Fig. 520

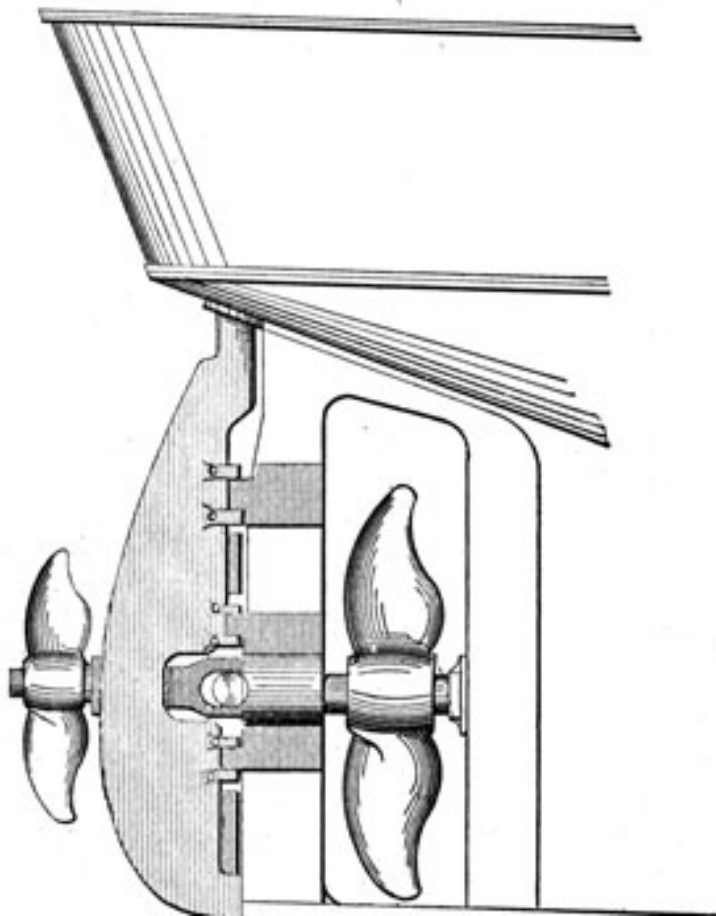
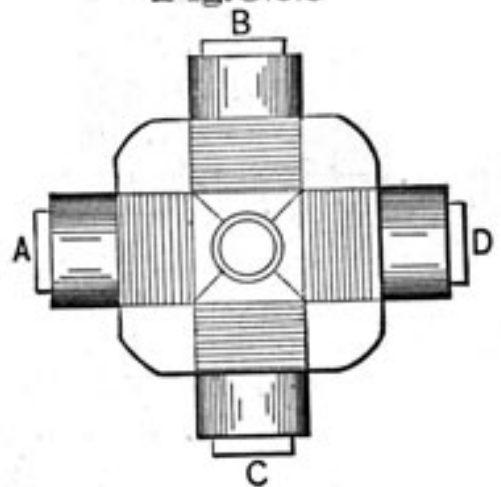


Fig. 522



"How many naval officers," says Fremantle,* "care to know the number of degrees of helm that can be given to their ships, the tending of the screw to turn the ship unassisted by the rudder, the effect of turning the engines ahead or astern when the ship has head or sternway, or what the reduction of speed by putting the helm hard over? These and other questions are simple points of seamanship; yet an officer who would consider himself disgraced if he could not answer at once as to the lead of the lower studding-sail halliards, which may not be supplied to the ship in which he is serving, will acknowledge without a blush that he does not know if the screw of the same ship is right or left-handed, or how many blades it has."

It would be more practical to realize that while the weather-gage and manoeuvres used in obtaining it have lost their importance, there are more urgent reasons now than ever existed in the old sailing days for good judgment on the part of the officers. Combined with accurate gun practice, the skilful handling of ships, *which is seamanship*, decides most naval actions. And this is as true when the results are achieved with propellers and steam steerers, as it was when they were obtained with braces, tacks and sheets. The motive power alone has changed-the principle remains.

* "Naval Tactics on the Open Sea," by Captain the Hon. E. R. Fremantle, R. N.

CHAPTER XXXVI.

GETTING ON SHORE-LEAKING-HEAVING DOWN.

When a vessel strikes, the first step is to brace aback if on a wind; to clew up and furl everything if before the wind, and if under steam, to reverse the engine. It may be possible, if she has struck on a sand-spit or knoll, to force her over into deep water, otherwise she should be *hove off as she went on*. The navigator should be at once despatched to sound around the ship, and the boom-boats be hoisted out. Carry out the stream-anchor and bring the cable to the capstan. Have careful hands in the chains by the lead to watch if she moves. Heave round and try to get her off. If she does not start, move the guns and men as necessary to change her trim. If this fails, send out a bower anchor and chain. While the boats are carrying out the anchor, send down the upper yards and top-gallant masts, and prepare to start the water and provisions. If still impossible to move her, start water, heave overboard guns and shot (supposing there is no hope from higher tides), and all heavy weights. The guns should be carried clear of the ship and buoyed, with buoy-ropes strong enough to weigh them. Construct rafts out of spare spars, to carry provisions, water, &c. Of course, if small vessels can be procured they will be used. While lightening the ship a good strain must be kept on the cables by which the ship is to be hove off. This is very important, and every time the purchases are observed to slack up, they should be set well taut again. In case the anchor comes home, back it with the stream.

Do not commence to lighten the ship until an anchor has been planted and a good strain hove on the cable, lest she go further on.

If a vessel is aground forward, shears may be raised over the bows, the heels resting on the bottom and the legs long enough to reach well above the bows; the object being to *lift* her by means of a heavy shear-head purchase. This method was once successfully tried with the United States sloop-of-war "Vincennes," but would not answer with any but the smaller class of ships.

Another instance is mentioned of a ship having run stem on very hard, and after unavailing efforts to get her off, hung on a rock abaft the foremast. All weights were run aft; balks of timber were placed athwartships forward of

the place where the ship hung, and projecting through the ports; perpendicular shores were placed under these from the ground; slung to the balks, and wedges prepared for driving between their outer ends and the shore-heads. Opportunity was then taken of the first increase of water to set up the wedges, remove the after weights and heave in on the purchases at the same time. On this the ship started immediately; and, by a repetition of the same process of leverage, was completely cleared of the rock.

Vessels draw much less water when hove keel out than when upright or heeling over. It is related that a certain vessel had been driven so far up on shore, in a heavy gale and unusually high tide, as to be considered irrecoverable, and was sold for the mere value of her timbers; the purchaser floated a scow alongside of her at high water, and hove the vessel keel out by her masts, and then warped the pair into deep water.

If the tide commences to fall while the vessel is still aground, she must be shored up to prevent falling on her broadside. The spare fore and main topmasts may be used for this purpose. Weight their heels with kentledge, bend on guys to place them, and let their heads take beneath the fore and main chains. Should she rest too heavily on the spars, send out kedges to the opposite side, and bringing the hawsers to the mastheads, set them taut to steady her. * At the next high tide try her again. If a steamer can be procured, let her tow in the direction you are heaving. If a ship is at hand to assist, she may anchor near, and, taking a hawser from you, heave at the same time.

When the vessel first strikes, and the sails are hove aback, or the engine reversed, the officer of the deck should send men in the lower rigging to shake the ship, sally from side to side, or move the guns aft quickly. These means often suffice to get the ship off.

If a ship bilges, all further efforts to get her afloat are of course abandoned. The first step in this case is to get the boats out, and then to keep her upright, saving as much of her effects as possible.

Ships sometimes get hard and fast after grounding, from neglecting to lay anchors out *before* lightening.

In some cases, the water close under the stern is too deep for anchoring.

It is reported that the bower anchors of an English man-of-war, that had grounded in the St. Lawrence, were transported over the decks; and, being let go from the quarters with a purchase on each, which was carried to the bows, the ship was hove off.

H. B. M. steamer "Gorgon," of twelve hundred tons and three-hundred-and-twenty-horse-power, was driven on shore

* Unnecessary with a flat-floored ship.

37

578

in a gale, near Montevideo, and imbedded in the sand to a depth of nearly twelve feet. Camels were constructed on the spot, tanks made water-tight by introducing fernaught and lead within their lids. Boilers were hoisted out and made water-tight, and these, with casks, &c., affording altogether a buoyancy equal to three hundred and sixty-seven tons, were secured under the ship by means of cables passed round the bottom. These appliances, together with screws, and heavy purchases leading to anchors planted astern, being duly prepared, the ship, on the tide filling the dock that had been dug about her, was rescued from her perilous condition. "The whole operation presents a picture of united energy and skill to which maritime records afford no parallel." The details of these operations have been narrated by one of the 'Gorgon's' officers, not only as an account of the means used to restore the ship, but likewise to point out to the young officer to what advantages the qualities of perseverance and forethought may be applied, if duly cultivated in early life."*

The dimensions of one of the camels, whose buoyancy was equal to sixty-two tons, is as follows:

Length	38 feet.
Height	7 feet 4 inches.
Breadth at top	5 feet 10 inches
Breadth at bottom	10 feet 4 inches

The planking was three-inch fir, doubled at the edges, and nailed on over seven frames, each nine inches by five.

Cases have been related where officers have thoughtlessly given the order, on the ship grounding, to let go an anchor. The impropriety of this is obvious, for there is great danger of the ship striking on it and bilging. For the same reason when guns are thrown overboard, care should be taken that they be not placed where there is a possibility of the ship striking on them.

When a ship has touched lightly or run into soft mud, a moderate-sized anchor and hawser run out astern and hove taut, may suffice. Then all that is requisite is to loosen her in her bed. This may be done by running in the guns on one side, and sending all hands on the opposite side to list her; by letting the crew sally from side to side by the stroke of the bell, or, as has been successfully tried on board the practice-ships, by manning the lower rigging and causing the crew to shake together.

If badly ashore, be careful not to bring the heaving-off cables over the stern, so that they may have a tendency to *bear it down* and press her heel on the bottom. Should both bowers be planted astern, bring the cables to the quarters outside, where hang them; now lash to them your heaviest

* Recovery of the "Gorgon," by Captain Key, R. N. This little work may be found in the Library of the Naval Academy, and is well worth reading.

blocks, say the cat, and toggle the fish block to the forward main deck port, also outside; reeve a hawser for a fall, and bring the hauling part from the cat in through an after port each side, taking one to each capstan, or use one capstan and a deck tackle. This gives a better lead.

SHIP ON SHORE. WEATHER FINE.

THERE BEING MUCH RISE AND FALL OF TIDE.

Out boats and plant stream in best direction. Hoist out spare spars, and commence shoring up as rapidly as possible, as she will be left high and dry at low water. As soon as well shored up and spars lashed and cleated, close all the ports and secure them.

Should it be a coral or rocky bottom, her safety will depend in a great measure on keeping her upright. Besides the spare spars take as many from aloft as possible; remove all weights from aloft, and run the guns in to a taut breeching. Get all weights from the side to the centre of the ship and lash them.

The finer the ship's bottom the more the danger to be apprehended from her heeling, and consequently the more the care required in shoring up.

If a full-bottomed ship, and one with a great deal of dead-rise, were both to get on the same rugged shore, the latter, supposing both to be kept upright, would stand the better chance, as she would rest on her keel alone, while the former would rest on her floor; if the two ships were heeled over and striking hard, the full ship would be in danger of bilging, while the sharp ship's lee side will be water-borne, and the ship striking on her keel.

Should both ships be left high and dry on "a hard" without shoring up, the full ship would be left nearly upright while the other would probably be lying on her beam ends. This is a critical position for a strong ship, and extremely dangerous for an old one.

In the matter of heaving off, the sharp ship, by taking the ground in fewer places and causing less friction, would give less trouble than one with a long, flat floor.

The foregoing remarks show the importance of officers being familiar with the model, or "lines" of their ship.

THE CASE OF THE "MONONGAHELA."

The U. S. steam sloop Monongahela (2100 tons displacement) was thrown on shore by a tidal wave at Santa Cruz, W. I., November, 1867, and an expedition for the floating of that vessel was sent from New

"Purveyor," taking along all the necessary material and twenty-six picked men, mostly shipwrights and caulkers, under the direction of the late Thomas Davidson, Jr., Naval Constructor, U. S. N.

The working party arrived at Santa Cruz (West End) Jan. 31st, 1868, and found the ship high and dry, broadside on, and heeled over at an angle of 15°. The rudder and steering post were broken, metal connection and main stern post gone below stern bearing, a considerable portion of the stern knee gone, after end of keel and garboard strakes gone for forty-five feet, the remaining keel badly chafed and in places broken to the bottom planking, the starboard bilge chafed nearly through the plank to the timbers in many places, twelve streaks of wall plank under the after pivot port on the port side broken, and the sheer line very much out of place on that side.

The badly chafed places of the starboard bilge were trimmed out and white pine plank filled in, caulked, made tight, and sheathing copper put on this side and the keel. Before the keel could be repaired or the ways put under for launching, it was necessary to raise the ship bodily two feet or more. Not having the power to do that at once, the rolling process was resorted to. This was done by placing white pine timber under the ship, filling the space from the bottom plank to the coral in line with the keel, and about five feet out. Hydraulic jacks were then placed under the port bilge, and the ship rolled on her starboard bilge, to a sharp angle. The keel was then carefully blocked, and the ship rolled back on her port bilge to her original position, the timber increased in thickness, &c., &c. This operation was gone through with several times, or until the keel was raised twenty-six (26) inches. After which, new after keel and garboard strakes were put in, posts and rudder repaired, and timber run out on either side to take the place of metal connection and secure the steering post. The propeller was unshipped and four sets of launching ways put under, extending to the water. Owing to the heavy surf which rolled in continuously, it was found impossible to lay the ways from the bank to deep water singly; and it was decided to prepare them about one-half mile south of the ship and near where she first came on shore. A diagonally braced framework or platform was first made, and on this the ways were laid and secured, and the whole fabric launched and towed to the ship, and the four ways connected at the same time, extending out from the land two hundred and thirty-seven (237) feet, or to 14 feet 6 inches depth of water. After the ways were connected, a very difficult job was performed in getting the depth of water at the blocking spots, which were taken four feet asunder. These depths had to be taken several times and an average adopted to get a correct grade. From the great unevenness of the bottom this was hard

to get correctly. After this, the blocking was secured and the whole mass sunk with kentledge. On the 4th of March an attempt was made to launch, but by the bursting of a 90 ton hydraulic jack the bow of the ship started too soon and had got ribband bound before the stern had got fairly started; when the stern did get started it went very fast, and before the bow could gather way again the stern had become ribband bound. It stopped between blocking, the ways broke, and the ship dropped in six feet of water aft and five feet forward. Fortunately, the packing remained in place, and the keel was kept clear of the bottom 18 to 20 inches. This gave the water a chance to breach through and prevented the sand from banking on the outside. All the material was picked up, new ways fitted and put under, the packing was removed by blasting. Anchors were laid out abreast the ship, and in the direction that she was to be hauled, broadside to; crabs put in place, tackles rove and shores made of white pine timber and plank strong enough to support the pressure of a 90 ton jack. Six of these shores were made. Tackles, chains, &c., were on the seaward side to haul out; shores, jacks, &c., on the land side, to *push* out. A jack was placed between each shore and the ship's side, to which both were hung by small tackles about three feet above the water, as also was a small stage on which the man stood that worked the jack.

The other end of the shore was backed by the coral at first, and as fast as the ship moved out the space was filled in with kentledge until a man tending this end was up to his waist in water. The shore was then taken down and lengthened. This was done several times until the last shores made were one hundred and thirty-five feet long and over eight feet wide.

After this manner the ship was pushed slowly out, broadside to, on her ways, until within one foot of floating draft, when the tackles relieved the jacks and in a short time the ship was afloat. The utmost care had to be taken with the tackles in order to preserve their effectiveness for the final effort, as the chains available were not of sufficient size to bear the capacity of the crabs, and were broken several times. They were of little assistance while the shoring out was in progress.

All the material was reshipped on the barque, the topside of the ship and the deck were caulked, and the broken walls planked over. The expedition reached New York on its return early in June, 1868.*

* The foregoing description is from information kindly supplied by Mr. W. F. Noyes, master carpenter at the Navy Yard, Portsmouth, N. H., who was a member of the expedition.

582

LEAKS.

Water passes as the square root of its altitude; that is, if we suppose equal holes to be made in the bottom of a vessel at one foot, four feet, nine feet, and sixteen feet beneath the surface of the sea, the water will rush in the holes with a velocity equal to the square root of their respective depths. If for example, 1 represents the velocity with which it enters at the first hole, the numbers 2, 3, and 4, will represent the velocity with which it enters the others.

After the water has risen in a vessel, it will rush in all the *covered* holes with the *same* velocity, regardless of their depths, which velocity will be represented by the square root of the difference between the level of the water within and without the vessel.

Suppose a ship drawing twenty feet to spring a leak sixteen feet below the water line, or four feet from the bottom of the vessel. The velocity with which the water enters this leak is represented by 4; but when the water has risen in the vessel, say eleven feet, the water will then enter with a velocity = $\sqrt{20-11}$ = $\sqrt{9}$ = 3; when the water has risen sixteen feet, the velocity will be represented by $\sqrt{4}$ = 2, etc. Hence it will be seen that although the pumps may not gain on the leak at first, yet they may do so after the water has risen inside the vessel above the leak.

In order to discover the locality of a leak, it is recommended to steer in different ways. If the leak increases when going ahead at full speed, it is probably forward, otherwise it is abaft. If it neither increases nor diminishes, it may be on either side; which may be discovered by going on different tacks.

Upon springing a-leak the pumps are at once manned and kept going. The carpenter then endeavors to discover it, and on doing so will stop it if possible from the inside. The hold or fore-peak may have to be broken out for this purpose. Sometimes by listening attentively, the noise of the water rushing in will betray its locality.

If the leak cannot be got at in any other way, and is a dangerous one, a sail may be "thrummed" and placed over the hole from outside.

Sails are thrummed as in making a mat. They are got over the bows, and hauled close up over the opening by guys and tackles. The most expeditious way to thrum a sail is to pour on hot pitch, and then tread oakum over it.

Should the leak be on one side, and near the water line, the ship may be hove about or listed; when the carpenter may get at it and nail over sheet lead, or planking lined with fernaught.

583

It is of course advisable, whenever possible, to stop leaks from the *outside*. Many ingenious devices have been resorted to for this purpose, when the ordinary methods of thrummed sails, mats, etc., have been unavailing.

The U. S. steamer "Proteus," in one of the blockading squadrons, was fitted with a chute for discharging ashes through the bottom of the ship. This consisted of an iron cylinder with the lower end bolted to the bottom of the vessel and the upper end, a little above the water line, closed with a tightly-fitting plate when not in use; the plate moved in and out by a lever, as required.

In a gale of wind the bottom fastenings of this cylinder commenced to work adrift, and a dangerous leak was developed at the lower end of the chute.

To stop the leak, the vessel was hove to, a wooden shot-plug was secured to the end of a rope, and just inside the shot-plug a small line with a deep-sea lead attached was connected to the same rope with a squilgee toggle, a line from the toggle being retained inboard. Shot-plug and lead were lowered through the chute, tending the tripping-line of the toggle. When enough rope had been paid out, the squilgee toggle was pulled out by its tripping-line. The lead went to the bottom, the shot-plug floated up alongside,

was grappled from the surface and taken inboard. Using the rope as a marrying line, a heavier line was hauled through the chute, and when its outboard end reached the deck it was made fast to a suitable plug formed of mattresses, hammocks, etc. By manning the other end of the line the improvised plug was hauled under the ship and tightly jammed in the bottom of the ash-chute, stopping the leak and probably saving the ship from foundering.

It is obvious that the reason for not using the heaviest line at first was that the shot-plug would probably not have floated it.

On board a merchant ship an extensive leak in a seam was effectually stopped, from outboard, as follows: The vessel being hove to, a rough bag was formed out of a tarpaulin with a broad flap cut in one side, loosely stitched on and the edge connected with a tripping-line, led to the deck. The bag being filled with sawdust, the mouth was sewn up and the bag drawn by lines passing under the keel to the vicinity of the leak, with the flap side nearest the ship. The flap being torn open by the tripping-line, the sawdust worked out and, mingling with the water, effectually closed the seam.

This method was successfully applied on board the U.S.S. Independence at Mare Island in overcoming an annoying leak in the run of the vessel.

As an instance of closing serious leaks from *inboard*, the case of the "Worcester" may be mentioned here. This vessel, when flag-ship of the North Atlantic squadron,

584

worked the Kingston valve entirely adrift from its fastenings during heavy weather, the result being that a solid stream of water nearly a foot in diameter commenced pouring in to the ship. Until some two or three feet of water were in the hold, all efforts to close the leak were unavailing, but finally a nine-inch shot (with its diameter suitably increased by wrapping in canvas) was rolled over the orifice of the leak by men up to their knees in the water. Assisted by the back pressure of the water in the vessel, two or three hands could keep the shot in place until it was secured there by a cross-piece of timber, one end of which was placed under one of the boilers, and the other end wedged down by a shore from under the berth-deck beams.

Should a vessel be found to leak very badly, she may, if in the vicinity of land, be beached, as a last resort; or, if near a harbor, be run in and put aground to keep her from sinking in deep water.

If in danger of going down, anchors, guns, &c., must be hove overboard, boats hoisted out, and rafts constructed for carrying men, provisions, and water.

No rules can be given for such cases. Much depends upon the example of coolness and energy set by the officers, and the general state of discipline. Much, too, depends in all emergencies upon the professional abilities of officers, their practical knowledge and *fertility of resource*.

The student is referred for accounts of shipwrecks, for the various means of rescuing people from stranded ships, for constructing rafts, &c., &c., to the professional works with which the Naval Academy

library is so generously supplied.

Heaving Down. When vessels have sustained injury in their bottom, and there are no opportunities for docking, recourse is then had to heaving down. Tackles are brought from the mastheads to the shore, or to another vessel, and these being hove on, turn the bottom up out of the water.

The following notes were taken at the heaving out of the United States frigate "Brandywine," at the Navy Yard, Brooklyn.

The wedges of the fore and main masts were knocked out, and the masts got entirely over to the weather partners, the stays were also set up afresh, two extra pairs of shrouds were got over each masthead, and set up to dead eyes toggled with a long strap to the main deck ports. (These shrouds were taken forward of the masts so as to equalize the strain between the forward and after shrouds.) Two small chains were middled and eyes formed in the bights, which were well parcelled; one was put over the mainmast head, and the other over the fore; the ends were taken in through the air ports abreast the respective masts, and well set up to stout Spanish windlasses, which were rigged on

the berth-deck in the securest manner possible; great care was taken that all the shrouds, extra shrouds, and chains, bore an equal strain.

Strong shores were placed against the heel of each mast, with their other ends leading up to the junction of the berth-deck beams to the side, where they were well wedged; these were to windward, and were to counteract the tendency of the heel going out of the step to windward when the strain of the purchases was felt to leeward; other shores had their upper ends resting against that part of the under side of the berth-deck which is directly over the keelson; the lower ends rested on the skin of the hold to leeward about midway between the keelson and the ends of the berth-deck beams, where they were firmly wedged; these were to support the body of the ship when down on her side.

Five bolts, three and a quarter inches in diameter at the large ends, and two and a quarter inches at the small ends, were driven through the side of the ship abreast of each mast, about one foot above the berth-deck, and well secured at their inner ends.

The camels or bolsters (being large frameworks of timber to protect the channels from the heels of the shores, and strong enough to bear the strain), were hoisted up by the pendant tackles and strung abreast the masts to windward. The shores were of white pine, seventy-five feet long, nineteen inches square at the heel, and thirteen and a half inches at the head, with a mortice cut through at each end; two were used for each mast, and they were got aloft by having a large three-fold block lashed at the masthead, and a purchase rove of a five and a half inch manilla fall; the lower block was lashed to the shore about one-quarter from the head, and thus each leg was hove up separately to windward; the masthead lashing was of new well-stretched four-inch rope, ten turns of which were passed through the mortice, *round and round*, and ten more *crossed*; the heels resting over the camels, were spread so that one might be as much forward as the other was abaft the mast, were gammoned to the bolts in the side with different sized white rope, after which the gammonings were well frapped together; three *spare shores* were lashed between the mast and each shore (making six for each mast), at equal distances, and belly lashings were hove on in the

same places.

With so much weight on one side, the ship heeled considerably, to counterbalance which, water-casks were lashed on the opposite side, and filled, which brought her upright again.

A large and a small purchase were used for each mast; the large purchase-blocks were four and a half feet in. length, the small ones two and three-quarters; the upper

586

blocks for the former were lashed to their respective mastheads, above the shores, with seven turns of a nine-inch manilla lashing, the upper blocks of the latter were lashed on with five turns of the same stuff; the lower blocks with their leaders strapped with a long and a short leg were toggled to the spar in the pits.

Three crabs were placed for each mast, one for each purchase, the third as a backer for the large one; these crabs were secured to anchors planted in the ground, which were also assisted by pigs of iron.

An anchor, to which the stream cable was bent, was planted in the water abreast the mainmast, the cable opposite the fore purchase was secured to a pile at a convenient distance abreast the foremast; both cables were taken under the keel through the spar-deck ports, and stout tackles clapped on them; the breast fasts were slacked and the ship hove off a sufficient distance by the cable, after which all was secured.

A pair of small but stout sheers, with a figure-of-eight head lashing and head guys, was raised near each pit and relieving tackles attached to the heads; a relieving tackle was also hooked to bolts in the wharf opposite to each mast and then to the gammoning bolts; the falls were rove, and the ship was steadied by them and the relieving tackles.

All the ballast was now got out and placed over the spar which ran through the pits, and to which the lower purchase blocks were toggled; the berth-deck was scuttled abreast the main hatchway, to leeward, and pumps rigged there; the ship was caulked thoroughly, the lee gun-deck ports closed in and caulked also, together with the air ports and scuppers.

All moveables were passed ashore, and the falls rove, the large falls were of eleven-inch manilla rope, the small one of eight-inch manilla rope; the purchases were three-fold; saddles, with rollers, were placed under the falls from the leaders to the crabs, and every precaution taken to prevent chafe; a spar-maker was stationed at the partners when heaving, to see when and how much the masts came over; the main came to within two inches of the lee partners, and the fore touched gently. As the mast-heads got below the sheer-heads on the wharf, the relieving tackles from the sheer-heads were hooked to stout straps around the mastheads; when keel out, the falls were well stoppered and bitted to the crabs, the relieving tackles hauled taut and shores put under the mastheads to assist the relieving tackles; the purchase falls were well covered with tarpaulins.

Every night the ship was righted, and on Saturday night the falls were unrove; previous to her being hove down the next day the frappings of the gammonings were always hove taut.

down the first time, which was the only accident which occurred.

In cases where the vessel has been dismasted, or where it would be impossible to procure sufficient length of purchase falls, &c., the bottom is turned out of the water by means of spur derricks. H. M. S. "Success," for instance, was thus repaired. The upper ends of the derricks were cleated on the ship's side, the lower, to which the purchase blocks were lashed, were secured from rising by turns of the chain cable, that were passed under the bottom from the opposite side, being steadied by guys led from forward and aft.

The after bearings of the "Croesus," a screw ship of twenty-five hundred tons, were, in the absence of a dock, recently repaired by means of a caisson, which, when placed, enclosed the heel of the ship from the foremost stern post aft.

It was formed sloping at the fore part from the base to the top, and sufficiently open at that part to admit the heel, the dimensions being twenty-two feet at base, fifteen feet at top, twenty feet in depth, and nine feet in breadth. Displacement about one hundred tons. It was sunk by loading it with chain cable, which was removed when the caisson was drawn forward into position by guys. The caisson was kept free by constantly working two seven-inch pumps; the stern of the ship being raised in consequence nineteen inches.

CHAPTER XXXVII.

THE LIFE-SAVING SERVICE OF THE UNITED STATES.

INSTRUCTIONS FOR SAVING DROWNING PERSONS.-RESTORATION OF THE APPARENTLY DROWNED.

GENERAL INFORMATION.*

LIFE-SAVING stations, life-boat stations, and houses of refuge are located upon the Atlantic and Pacific seaboard of the United States, the Gulf of Mexico, and the Lake coasts. Their positions are given in the List of Lights supplied to every vessel of war.

All stations on the Atlantic coast from the eastern extremity of the State of Maine to Cape Fear, North Carolina, are manned annually by crews of experienced surfmen from the 1st of September until the 1st of May following.

Upon the Lake coasts the stations are manned from the opening until the close of navigation, and upon the Pacific coast they are open the year round, but, with the exception of stations at San Francisco, Cal., and at Baker's Bay, Wash. Ter., are not manned, depending upon volunteer effort from the neighboring people

in case of shipwreck.

All life-saving and life-boat stations are fully supplied with boats, wreck-gun, beach apparatus, restoratives, &c.

Houses of refuge are supplied with boats, provisions, and restoratives, but not manned by crews; a keeper, however, resides in each throughout the year, who after every storm is required to make extended excursions along the coast with a view of ascertaining if any shipwreck has occurred and finding and succoring any persons that may have been cast ashore.

Houses of refuge are located exclusively upon the Florida coast, where the requirements of relief are widely different from those of any other portion of the seaboard.

Most of the life-saving and life-boat stations are provided with the International Code of Signals, and vessels can, by opening communication, be reported, or obtain the latitude and longitude of the station where determined, information

* From "Instructions to Mariners in Case of Shipwreck," Treasury Department Doc. No. 75. For the organization of the Life-Saving Service of the United States the nation is chiefly indebted to S. I. Kimball, the present Superintendent of that service.

589

as to the weather probabilities in most cases, or, if crippled or disabled, a steam tug or revenue cutter will be telegraphed for, where facilities for telegraphing exist, to the nearest port if requested.

Destitute seafarers are provided with food and lodgings at the nearest station by the government as long as necessarily detained by the circumstances of shipwreck.

The station crews patrol the beach from two to four miles each side of their stations four times between sunset and sunrise, and if the weather is foggy the patrol is continued through the day.

Each patrolman carries Coston signals. Upon discovering a vessel standing into danger he ignites one of them, which emits a brilliant red flame of about two minutes duration, to warn her off, or should the vessel be ashore to let her crew know that they are discovered and assistance is at hand.

If the vessel is not discovered by the patrol immediately after striking, rockets or flare-up lights should be burned, or, if the weather be foggy, guns should be fired to attract attention, as the patrolman may be some distance away on the other end of his beat.

Masters are particularly cautioned, if they should be driven ashore anywhere in the neighborhood of the stations, especially on any of the sandy coasts where there is not much danger of vessels breaking up immediately, to remain on board until assistance arrives, and under no circumstances should they attempt to land through the surf in their own boats until the last hope of assistance from the shore has vanished. Often when comparatively smooth at sea a dangerous surf is running which is not perceptible four

hundred yards off shore, and the surf when viewed from a vessel never appears as dangerous as it is. Many lives have unnecessarily been lost by the crews of stranded vessels being thus deceived and attempting to land in the ship's boats.

The difficulties of rescue by operations from the shore are greatly increased in cases where the anchors are let go *after entering the breakers*, as is frequently done, and the chances of saving life correspondingly lessened.

INSTRUCTIONS.

Rescue with the Life-Boat or Surf-Boat. The patrolman after discovering your vessel ashore and burning a Coston signal hastens to his station for assistance. If the use of a boat is practicable, either the large life-boat is launched from its ways in the station and proceeds to the wreck by water, or the lighter surf-boat is hauled overland to a point opposite the wreck and launched, as circumstances may require.

590

Upon the boat reaching your vessel, the directions and orders of the keeper (who always commands and steers the boat) should be implicitly obeyed. Any headlong rushing and crowding should be prevented, and the captain of the vessel should remain on board, to preserve order, until every other person has left.

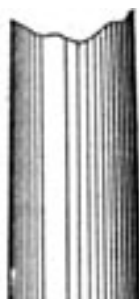
Women, children, helpless persons, and passengers should be passed into the boat first.

Rescue with the Breeches-Buoy or Life-Car. Should it be inexpedient to use either the life-boat or surf-boat, recourse will be had to the wreck-gun and beach apparatus for the rescue by the breeches-buoy or the life-car.

A shot with a small line attached will be fired across your vessel.

Get hold of the line as soon as possible and haul on board until you get a tail-block with a whip or endless line rove through it. This tail-block should be hauled on board as quickly as possible to prevent the whip drifting off with the set or fouling with wreckage, &c. Therefore, if you have been driven into the rigging where but one or two men can work to advantage, cut the shot-line and run it through some available block, such as the throat or peak halliards block or any block which will afford a clear lead, or even between the ratlines, that as many as possible may assist in hauling.

Attached to the tail-block will be a tally-board with the following directions in English on one side and French on the other:



"Make the tail of the block fast to the lower mast, well up. If the masts are gone, then to the best place you can find. Cast off shot-line, see that the rope in the block runs free, and show signal to the shore."

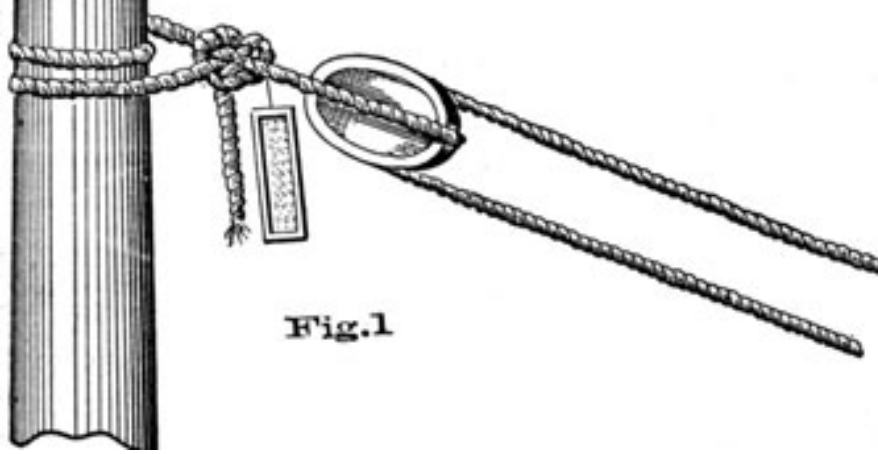


Fig.1

The above instructions being complied with, the result will be as shown in Fig. 1.

As soon as your signal is seen a three-inch hawser will be bent on to the whip and hauled off to your ship by the life-saving crew.

If circumstances will admit, you can assist the life-saving

crew by manning that part of the whip to which the hawser is bent and hauling with them.

When the end of the hawser is got on board a tally-board will be found attached, bearing the following directions in English on one side and French on the other:

"Make this hawser fast about two feet above the tail-block, see all clear, and that the rope in the block runs free, and show signal to the shore."

These instructions being obeyed, the result will be as shown in Figure 2.

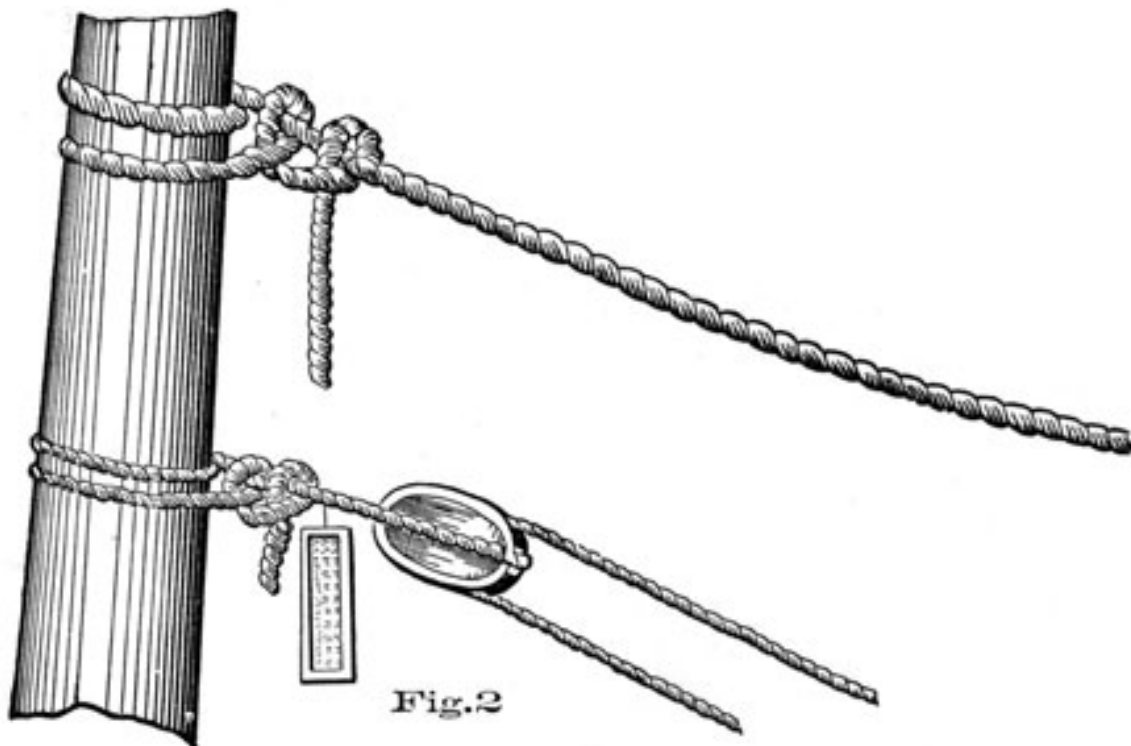


Fig.2

Take particular care that there are no turns of the whip line round the hawser before making the hawser fast.

When the hawser is made fast, the whip cast off from the hawser, and your signal seen by the life-saving crew, they will haul the hawser taut and by means of the whip will haul off to your ship a breeches-buoy suspended from a traveller-block, or a life-car from rings, running on the hawser.

Figure 3 represents the apparatus rigged, with the breeches-buoy hauled off to the ship.

If the breeches-buoy be sent, let one man immediately get into it, thrusting his legs through the breeches. If the life-car, remove the hatch, place as many persons into it as it will hold (four to six), and secure the hatch on the outside by the hatch-bar and hook, signal as before, and the buoy or car will be hauled ashore. This will be repeated until all are landed. On the last trip of the life-car the hatch must be secured by the inside hatch-bar.

In many instances two men can be landed in the breeches-buoy at the same time by each putting a leg through a leg of the breeches and holding on to the lifts of the buoy.

Children, when brought ashore by the buoy, should be in the arms of older persons or securely lashed to the buoy. Women and children should be landed first.

In signalling as directed in the foregoing instructions, if in the daytime, let one man separate himself from the rest and swing his hat, a handkerchief, or his hand; if at night, the showing of a light, and concealing it once or twice, will be understood; and like signals will be made from the shore.

Circumstances may arise, owing to the strength of the current or set, or the danger of the wreck breaking up immediately, when it would be impossible to send off the hawser. In such a case a breeches-buoy or life-car will be hauled off instead by the whip, or sent off to you by the shot-line, and you will be hauled ashore through the surf.

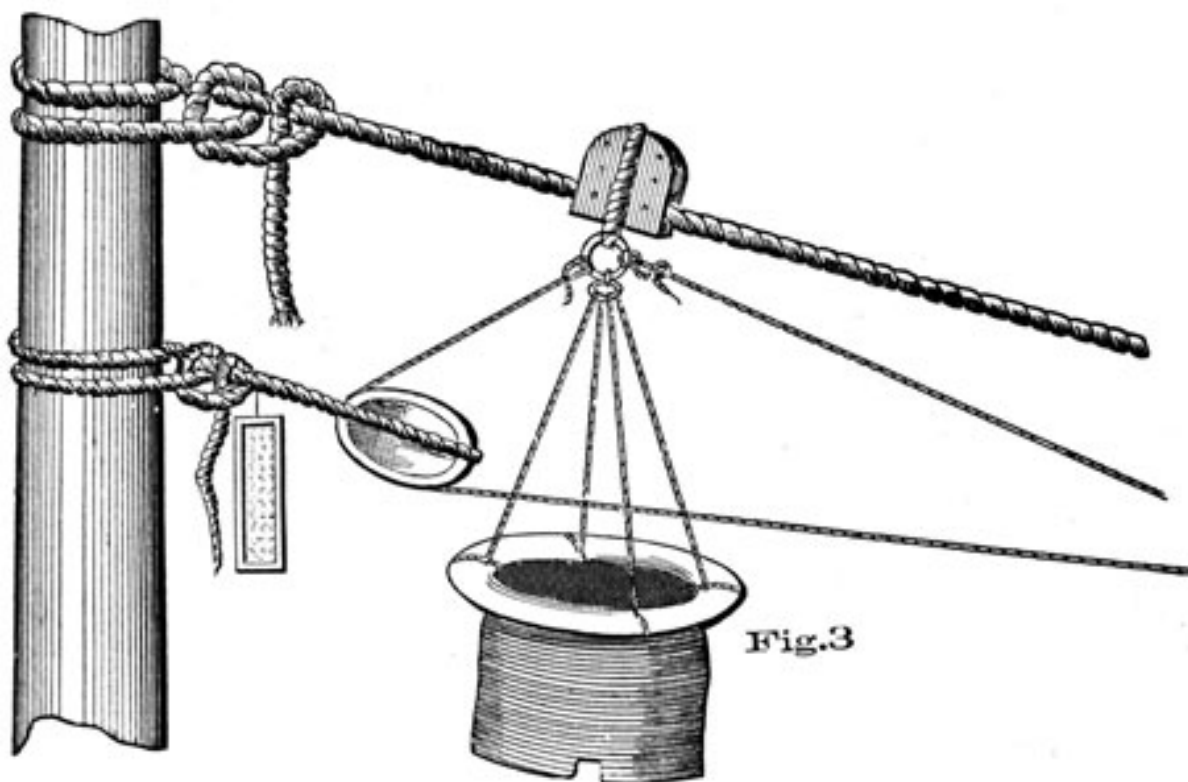


Fig. 3

If your vessel is stranded during the night and discovered by the patrolman, which you will know by his burning a brilliant red light, keep a bright lookout for signs of the arrival of the life-saving crew abreast of your vessel.

From one to four hours may intervene between the burning of the light and their arrival, as the patrolman will have to return to his station, perhaps three or four miles distant, and the life-saving crew draw the apparatus or surfboat through the sand or over bad roads to where your vessel is stranded.

Lights on the beach will indicate their arrival, and the sound of cannon-firing from the shore may be taken as evidence that a line has been fired across your vessel. Therefore upon hearing the cannon make strict search aloft, fore and aft, for the shot-line, for it is almost certain to be

593

there. Though the movements of the life-saving crew may not be perceptible to you, owing to the darkness, your ship will be a good mark for the men experienced in the use of the wreck-gun, and the first shot seldom fails.

RECAPITULATION.

Remain by the wreck until assistance arrives from the shore, unless your vessel shows signs of immediately breaking up.

If not discovered immediately by the patrol, burn rockets, flare-up, or other lights, or, if the weather be foggy, fire guns.

Take particular care that there are no turns of the whip line round the hawser before making the hawser fast.

Send the women, children, helpless persons, and passengers ashore first.

Make yourself thoroughly familiar with these instructions, and remember that on your coolness and strict attention to them will greatly depend the chances of success in bringing you and your people safely to land.

NOTE.-Similar rules apply to the use of the rocket apparatus on the shores of Great Britain.

In the British instructions the signals made from on shore (to haul in, &c.) are made by a man, separated from the rest, waving a red flag in the day time or flashing a *red* light at night.

INSTRUCTIONS FOR SAVING DROWNING PERSONS.*

1st. When you approach a person drowning, in the water, assure him with a loud and firm voice that he is safe.

2d. Before jumping in to save him, divest yourself as far and as quickly as possible of all clothes; tear them off if necessary, but if there is not time, loose, at all events, the foot of your drawers if they are tied, as, if you do not do so, they fill with water and drag you.

3d. On swimming to a person in the sea, if he be struggling do not seize him then, but keep off a few seconds till he gets quiet; for it is sheer madness to take hold of a man when he is struggling in the water, and if you do so you run a great risk.

4th. Then get close to him and take fast hold of the hair of his head, turn him as quickly as possible on to his back, give him a sudden pull and this will cause him to float;

* From a letter addressed by Joseph R. Hodgson, of Sunderland, to the Royal Humane Society.

38

then throw yourself on your back also, and swim for the shore, both hands having hold of his hair, you on your back and he also on his, and of course his back to your stomach. In this way you will get sooner and safer ashore than by any other means, and you can easily thus swim with two or three persons; the writer has often, as an experiment, done it with four, and gone with them forty or fifty yards in the sea. One great advantage of this method is that it enables you to keep your head up, and also to hold the person's head up you are trying to save. It is of primary importance that you take fast hold of the hair, and throw both the person and yourself on your backs. After many experiments, I find this vastly preferable to all other methods. You can, in this manner, float nearly as long as you please, or until a boat or other help can be obtained.

5th. I believe there is no such a thing as a death-*grasp*; at least, it must be unusual, for I have seen many persons drowned, and have never witnessed it. As soon as a drowning man begins to get feeble and to lose

his recollection, he gradually slackens his hold, until he quits it altogether. No apprehension need, therefore, be felt on that head when attempting to rescue a drowning person.

6th. After a person has sunk to the bottom, if the water be smooth, the exact position where the body lies may be known by the air-bubbles, which will occasionally rise to the surface, allowance being of course made for the motion of the water, if in a tide-way or stream, which will have carried the bubbles out of a perpendicular course in rising to the surface. A body may be often regained from the bottom before too late for recovery, by diving for it in the direction indicated by these bubbles.

7th. On rescuing a person by diving to the bottom, the hair of the head should be seized by one hand only, and the other used in conjunction with the feet in raising yourself and the drowning person to the surface.

8th. If in the sea, it may sometimes be a great error to try to get to land. If there be a strong outsetting tide, and you are swimming either by yourself, or having hold of a person who cannot swim, then get on to your back, and float till help comes. Many a man exhausts himself by stemming the billows for the shore on a back-going tide, and sinks in the effort, when, if he had floated, a boat or other aid might have been obtained.

9th. These instructions apply alike to all circumstances, whether the roughest sea or smooth water.

JOSEPH R. HODGSON.

Important to Bathers. Avoid bathing within TWO hours after a meal.

Avoid bathing when exhausted by fatigue or from any other cause.

Plate 128

Fig. 523





Fig. 524



595

Avoid bathing when the body is cooling after perspiration.

Avoid bathing altogether in the open air if, after having been a short time in the water, there is a sense of chilliness with numbness of the hands and feet; but

Bathe when the body is of normal warmth, and not overheated.

Avoid chilling the body by sitting or standing **UNDRESSED** on the banks or in boats after having been in the water.

Avoid remaining too long in the water-leave the water immediately there is the slightest feeling of chilliness.

The vigorous and strong may bathe early in the morning on an empty stomach.

The young, and those who are weak, had better bathe two or three hours after a meal-the best time for such is from two to three hours after breakfast.

Those who are subject to attacks of giddiness or faintness, and those who suffer from palpitation and other sense of discomfort at the heart, should not bathe without medical advice.

RESTORATION OF THE APPARENTLY DROWNED,

1st. INSTANTLY turn patient downward, with a firm roll of clothing under the stomach and chest. Place one of his arms under his forehead, so as to keep his mouth off the ground.

Press with all your weight (placing the hands on each side of the chest), two or three times, for four or five seconds each time, so that the water is pressed out of the lungs and stomach and drains freely out of the mouth. Fig. 523, Plate 128.

2nd. THEN QUICKLY turn patient face upward, with roll of clothing under the back, just below the shoulder blades, and make the head hang as low as possible.

Place patient's hands above his head. Draw the tongue out of the mouth, using forceps, a noose of string or a handkerchief.

Kneel with patient's hips between your knees, and fix your elbows firmly against your hips.

Now, grasping lower part of patient's naked chest, squeezing his two sides together, press gradually forward with all your weight, for about three seconds, until your mouth is nearly over mouth of patient-then with a push, suddenly jerk yourself back. Fig. 524, Plate 128.

Rest about five seconds, then begin again, repeating these bellows-blowing movements with perfect regularity, so that foul air may be pressed out and pure air be drawn into the lungs about eight or ten times a minute, for at least one hour, or until patient breathes naturally.

NOTE. Operate on the spot and *at once*. Prevent crowding around the patient.

Do not interrupt the first natural effort at breathing. After breathing is regular, rub dry and give hot water and spirits, in small doses.*

The coxswain of each boat should be instructed in the above method, or some other one equally good, and be required to pass quarterly inspection as to proficiency in performing the operation.

TREATMENT OF THE APPARENTLY DEAD.

I. If from Intense Cold. Rub the body with snow, ice, or cold water. Restore warmth by slow degrees, and give stimulants as soon as they can be swallowed. In these accidents it is highly dangerous to apply heat too early.

II. If from Intoxication. Lay the individual on his side on a bed with his head raised. The patient should be induced to vomit, for which purpose emetics may be given. Avoid stimulants.

III. If from Sunstroke. The term may represent one of two conditions, viz.: heat *apoplexy* and heat *exhaustion*, requiring different methods for relief. They are thus contrasted:

Heat apoplexy is distinguished by a flushed face, unconsciousness, throbbing temples, heat of head and body, snoring respiration and strong pulse. Treat it by raising the head and shoulders, applying ice or cold cloths to the head and leeches behind the ears, mustard to the lower limbs, no stimulants.

Heat exhaustion is distinguished by a pale face, unconsciousness if present, is partial, no unusual heat of head; body cold, perspiring, or both; breathing quick but not noisy; pulse feeble. Treat it by applying ammonia *carefully* to the nostrils, administering hot whiskey and water in table-spoonfuls, leaving the head on a level with the body, and applying ice or cold cloths to the head and mustard to the spine, stomach and limbs.

Prevention. Wear, loose and light clothing, with a wet paper or sponge in the hat; avoid the use of spirits, overexertion, over-use of cold water, and exposure in the sun when the thermometer is above 85°, especially if the relative humidity of the air is great.

NOTE. A person who has simply fainted from exhaustion, etc., should be placed *flat* and the head should not be raised; cold water should be sprinkled liberally on the face, and the extremities chafed to restore circulation.

* Method suggested by Benjamin Howard, M. D., F. R. C. S.

"There is no breathing or heart's action; the eyelids are generally half closed; the pupils dilated; *the jaws clenched*; the fingers semi-contracted; the tongue appearing between the teeth, and the mouth and nostrils are covered with a frothy mucus. Coldness and pallor of surface increase."

The above remarks are copied from the instructions of the Royal Humane Society. Recent experiments, notably those of the late Dr. De Labordette, of the French Life Saving Association, tend to disprove the belief that "clenching of the jaws" is a sign of death. According to that authority, the first clenching of the jaws after a few minutes of immersion is a proof that life still exists. At any rate, it should not be accepted by an unprofessional person as a sign of death.

It is presumed that in no case efforts to restore life will be abandoned excepting by competent medical advice.



[Previous Part](#)



[Seamanship
Home Page](#)



[Next Part](#)

Copyright (C) 2006 [Historic Naval Ships Association](#)

All Rights Reserved

[Legal Notices and Privacy Policy](#)

Version 1.00, 24 Apr 06

ROPE-MAKING.

IN rope-making, the fibres of hemp, not averaging more than three and a half feet in length, must necessarily be overlapped among themselves and compressed together so as not to be drawn apart. The required compression is given by twisting, the fibres being continuously drawn out together, from a bundle, in the right quantity to produce the required size of *thread* or *yarn*. Yarns are then combined by twisting, and form a strand; three or four strands, by twisting, form a rope, and three or four ropes, a cable. These successive steps, in each of which the twist is reversed, cause the strain to be more equally diffused among the fibres than it would be if these were laid together in sufficient quantity at once and twisted, and moreover, the alternating directions given to the twist in the several operations, cause the different portions to bind upon themselves, and form a permanently firm bundle. The fibres only once twisted, make but a loose bundle, which, though decidedly stronger than the same quantity made into a hard-twisted rope, is not so durable nor so well adapted to the ordinary purposes of rope.* The actual loss in strength, by twisting, as found by trial, is about one-third the full strength of the fibre; its loss in length, from the same cause, being also one-third.

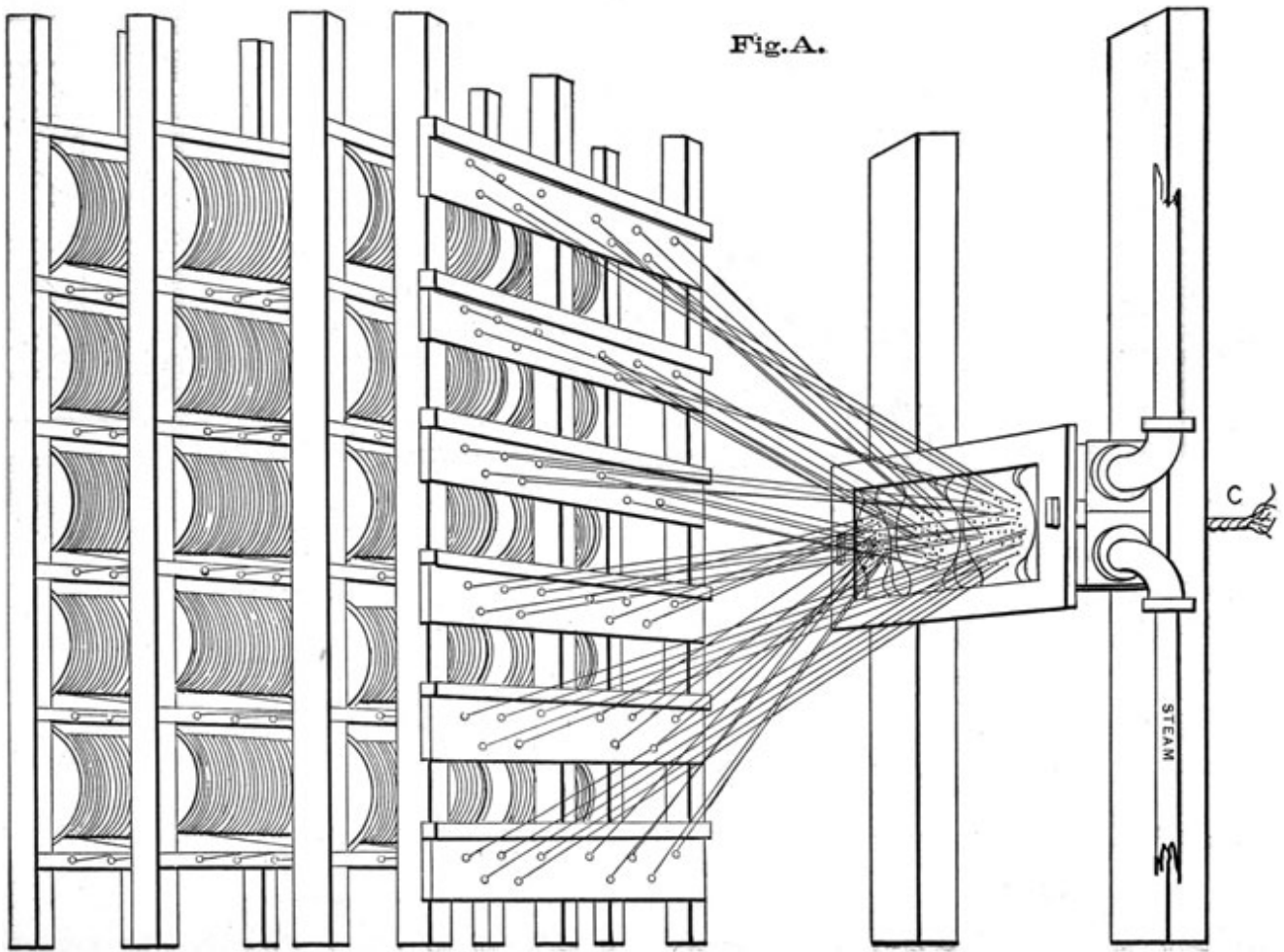
Rope is made in long buildings called rope-walks, and the process may be described briefly as follows:

Hemp, the material commonly used, is first hackled, or combed out, to remove the dust and tow. The hackle consists of a strong board, holding in a vertical position long steel prongs sharply pointed and polished. The hackling is done by hand.

The "preparation machines" prepare the hemp still further for spinning into yarn by a finer process of hackling. First is the "spreader," a machine having two endless chains fitted with gill-bars and gill-pins (steel teeth), which combs or straightens out and evens the fibres. The spreader is fed with the hackled hemp at one end, and throws it out in a "sliver" from the other. From the spreader the sliver is passed through two or more "drawing-frames," by which it is drawn down still more, and the fibres still further combed out straight, the size of the sliver being reduced at each step. The drawing-frame is similar to the spreader, but has only one chain. The sliver is now passed to the spinner, where it is spun into yarn, and at the same time reeled upon a bobbin. A recent improvement in the spinner, *tubes* the yarn, rendering it smoother and more even than any process yet devised, leaving little to be desired in the manufacture of rope. The yarn is spun right-handed. The size of the yarn varies according to the kind of rope for which it is intended. *Forties*-so-called because forty yarns will just fill a half-inch tube-are for the finer kinds of rope; twenties, requiring twenty to fill the tube, are for cables, hawsers, etc. From the spinning-room the bobbins containing the yarn are taken to the tar-house, where they are placed in frames conveniently arranged with reference to the tar-box. This is a long box filled

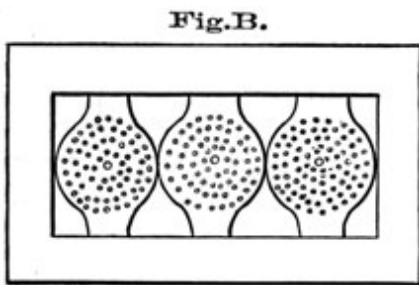
* The wires which compose the cables of the East River Suspension Bridge (N. Y.) are not "laid-up," or twisted, but are run straight and bound together.

with tar kept during the operation of tarring at a temperature of 220° F. by means of steam heaters. The yarns are led from the bobbins in the frame through two or more guide-plates working in a vertical plane over the tar-box, and convenient for lowering into the tar; thence to the farther end (between metal rollers, which press out and return to the box the superfluous tar) on to a



large wooden drum to cool them; through fair-leaders, and finally to a fresh set of bobbins, where they are wound up with the utmost regularity.

Rigging is so much exposed to moisture and heat that hemp would soon decay if not protected. Tar, though really injurious in its effects upon the hemp fibre, has been found indispensable to its general preservation. The weight of



adapted to the size of the strand,

the yarn is increased from sixteen per cent. to twenty per cent. by the amount of tar required.

The bobbins containing the tarred yarn now go to the laying-ground, for *hauling down*, or making into strands. The laying-ground, where the rope is laid up, occupies the entire length of the rope-walk. The yarns for the strands, generally three in number, are led from the bobbins, in Fig. A, through holes bored in concentric circles in the frame. Fig. B, thence through a tube

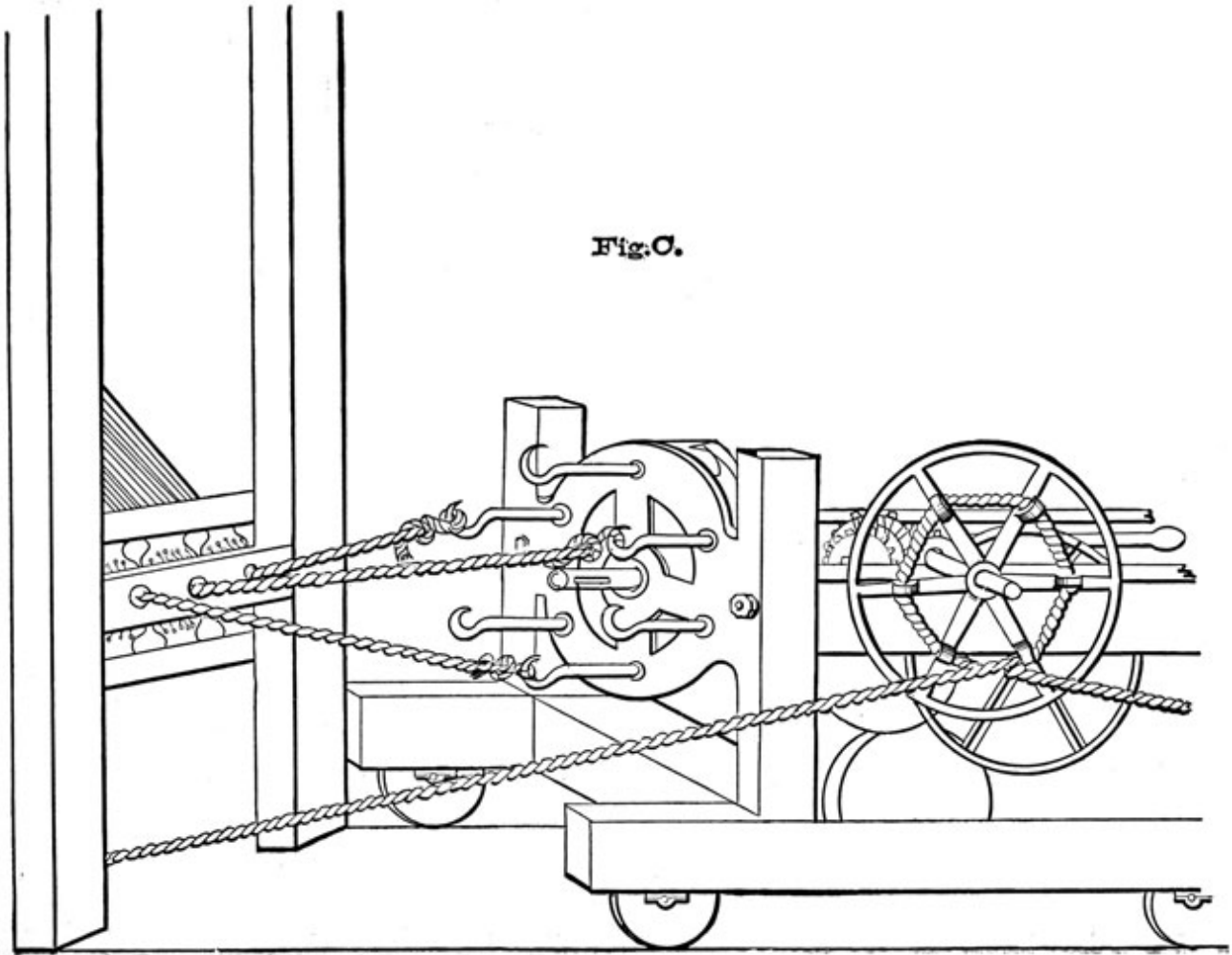


Fig. C.

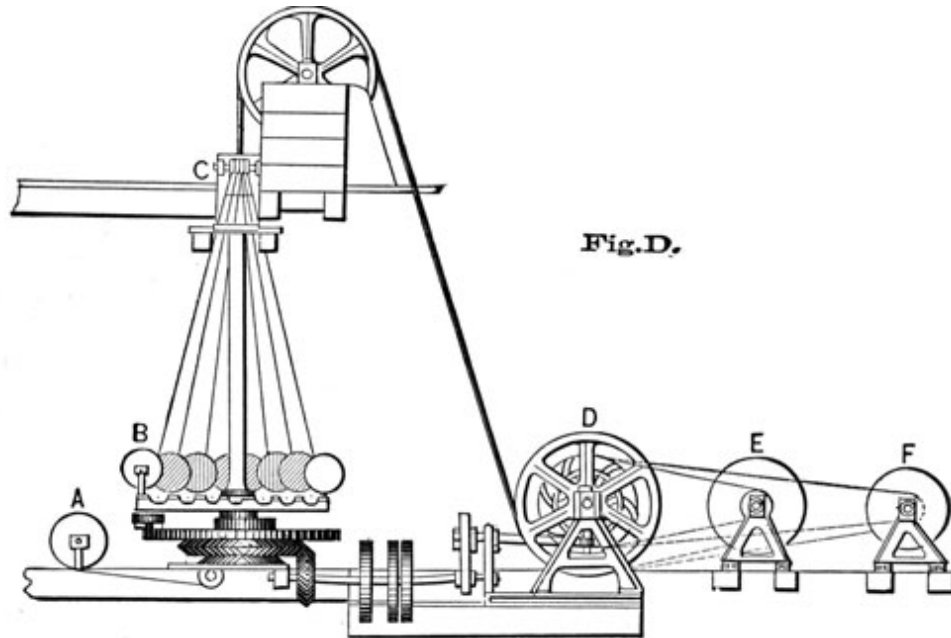
601

and attached to a hook on the end of a spindle in a movable machine like a car, called the *former*, Fig. C.

There is a plate, tube and hook for each strand; and the number of yarns to a strand is regulated by the size of the intended rope. All being ready, the machinery is put in motion, when the former is drawn down the walk, and the yarns, as they are hauled through the tubes, are formed into left-handed strands. *Closing* the strands is the next step, for which two machines are used. The lower one—the *layer*—lays up or closes the rope, and is movable; the upper one, which keeps the proper twist in the strand while laying, is stationary. Each strand being secured to its proper spindle, the machinery is put in motion and the strands hardened. A press attached to the layer prevents too much drawing up as the strands shorten by the additional twisting. After hardening, the strands are placed together on a central spindle of the layer and closed, a *top* inserted between them preventing too rapid closing. The *top* is a wooden cone with grooves cut to hold the strands, while tails of soft rope attached to it, by being applied to the rope as it is made, still further prevent, by the additional friction, the too rapid closing of the rope. The layer makes two revolutions to one of the upper machine. The skill of the ropemaker consists in knowing how to gear his preparation machines so as to draw a clean and uniform sliver; in giving the proper degree of twist to the yarn and strand; and in regulating the amount of hardening and the speed of the top in closing.

The foregoing process gives right-handed, tarred rope of three strands, or *plain-laid* rope. If the yarns are not tarred we should have *white* rope.

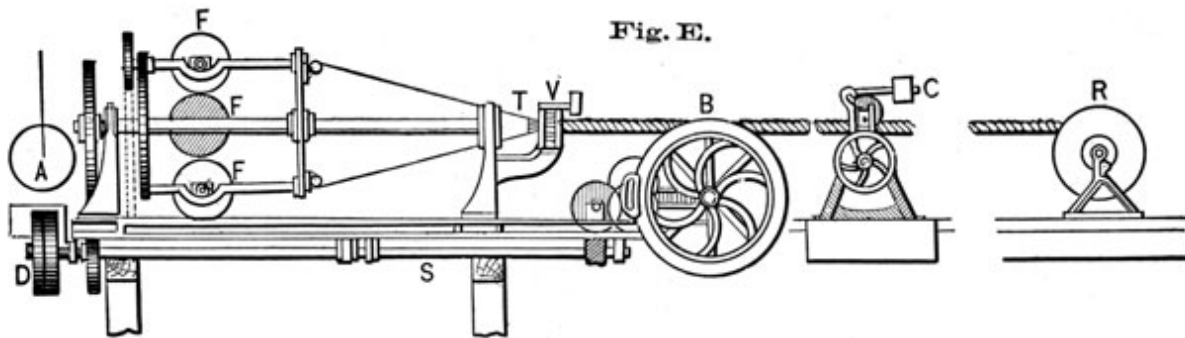
In the manufacture of *manilla* rope the first step in the foregoing description, hackling by hand, is omitted as being unnecessary; the manilla is oiled to enable the harsher fibre to pass the more readily through the preparation machines, and the yarns are not tarred, excepting when large hawsers are made, in which case the *outside* yarns are passed through the tar trough before laying up.



Twelve-flyer machine for forming strands. A, heart; B, bobbins; C, top and tube; D, draw-off drum; E, bobbins for large sizes; F, bobbins for small sizes.

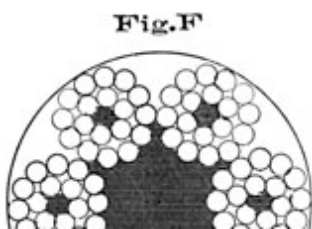
Wire Rope may be made either of forty-nine coarse wires or one hundred and thirty-three fine wires, put in six strands, and seven or fourteen "hearts"

To make a one-inch fine wire rope, fill the bobbins of a "six-flyer" machine similar to Fig. D, with what is known as No. 8 wire, Birmingham gauge. And



A, hear; B draw off drum; D, driving pulley; F, bobbins; T, top; V, tube; S driving shaft; R, reel.

for the heart, lead a single wire from its bobbin up through the vertical shaft. This will form a seven-wire heart for the strands. Next fill the bobbins of a twelve-flyer machine with the same size wire. Pass all the wires up through holes, pass the top, arrange the wires through the grooves of the top, twist them together by hand, splice in a piece of rope and pass it five or six times around the draw-off drum. Friction straps attached to the bobbins preserve an equal tension on the wires. Putting, now, the machine in motion, the seven-wire heart is drawn up the shaft, and at the same time the twelve single wires are wrapped about it as the disc revolves, each separate bobbin turning on its own centre in the opposite direction, so as to avoid twisting the wire. As the strand is formed it is reeled upon a bobbin. Having filled seven bobbins, six are placed in a *laying-up machine*, Fig. E, and one in rear for a heart. The heart, on motion being given to the machinery, is drawn through and the six strands wrapped about it, giving six outer and one central strand of nineteen wires each.



In making strands for wire rigging, it is the practice to substitute hemp for the single wire of the heart for the strands, and to make a hemp heart for the rope also. Fig. F shows a section of such a rope, where the hearts are of hemp.

The following table shows relative strength of the different kinds of rope;



Table of comparative dimensions of chain-cables, hemp rope, iron and steel rope, their weight per fathom, and breaking-strain.

Breaking strain of wire and hemp ropes	Approximate size of chains corresponding thereto	Circumference			Weight per fathom					Size of wire used in rope (iron and steel)		Remarks
		Hemp Rope.	Iron wire rope.	Steel wire rope.	Chain as weighted at Washington Navy Yard.	Hemp rope, tarred.	Hemp rope, not tarred.	Iron wire rope.	Steel wire rope.	Circumference of rope.	Number of wires.	
Pounds.	Inches.	In.	In.	In.	Lbs.	Lbs.	Lbs.	Lbs.	Lbs.	In.	B.W.G.	
4,880	5/16	2 1/2	1 1/4	7/8	5.18	1.48	1.25	1.28	-	1 1/4	22	Steel and iron wire rope, in accordance with this table, have a hemp heart. The sizes of the wire given are those in use at the government rope-walk at the navy-yard, Boston, Mass. No data for the weight of steel ropes smaller than 1 1/4 inches. Proof strains to be as nearly as possible on-half the breaking strain. In practice it is advisable to take it at 3/7 of the average breaking strain.
7,040	5/16 full	3	1 1/2	1 1/6	-	2.12	1.77	1.72	-	1 1/2	21	
8,260	3/8 scant	3 1/8	1 5/8	1 1/8	-	2.46	1.87	2.12	-	1 5/8	21 full.	
9,580	3/8	3 1/4	1 3/4	1 1/4	7.70	2.66	2.03	2.49	1.29	1 3/4	20	
11,000	3/8 full	3 1/2	1 7/8	1 3/8	-	2.76	2.30	3.06	1.60	1 7/8	20 full.	
12,520	7/16	4	2	1 1/2	11.11	3.72	3.09	3.22	1.74	2	19	
14,130	7/16 full	4 1/2	2 1/8	1 5/8	-	4.67	3.89	3.65	2.14	2 1/8	19 full.	
15,840	1/2	4 3/4	2 1/4	1 3/4	14.08	5.69	4.33	4.15	2.51	2 1/4	18	
19,560	9/16	5 1/4	2 1/2	1 7/8	18.64	6.94	5.29	5.27	3.09	2 1/2	18 full.	
23,660	5/8	5 3/4	2 3/4	2	22.20	8.33	6.35	6.31	3.25	2 3/4	17	
28,160	11/16	6 1/2	3	2 1/8	25.81	9.66	8.05	7.46	3.68	3	16	
33,050	3/4	7 1/4	3 1/4	2 1/4	30.31	12.78	10.09	8.97	4.19	3 1/4	16 full	
38,330	3/4 full	7 3/4	3 1/2	2 1/2	-	14.35	11.52	10.69	5.32	3 1/2	15	
44,000	13/16	8	3 3/4	2 5/8	37.73	14.65	12.21	12.72	5.97	3 3/4	14	
50,060	7/8	8 1/2	4	2 3/4	41.71	16.57	13.80	14.81	6.37	4	14 full.	
56,520	15/16	9	4 1/2	3 1/8	47.81	18.48	15.48	16.71	8.35	4 1/4	13	
63,360	1	9 1/2	4 1/2	3 1/4	55.16	20.71	17.25	18.95	9.05	4 1/2	13 full	
70,580	1 1/16	10 1/8	4 3/4	3 5/8	66.44	25.83	19.68	21.40	10.02	4 3/4	12	
78,220	1 1/8	11	5	3 1/2	75.27	27.82	23.20	24.20	10.79	5	12 full.	
86,240	1 3/16	11 1/4	5 1/4	3 3/4	83.64	30.57	24.29	27.15	12.84	5 1/4	11	
94,650	1 3/16 full	11 3/4	5 1/2	4	90.40	33.54	26.50	30.52	14.95	5 1/2	11 full.	
103,450	1 1/4	12 1/4	5 3/4	4 1/4	-	36.40	28.80	33.95	16.87	5 3/4	10	
112,640	1 5/16	13 1/2	6	4 3/8	102.22	44.17	34.99	37.70	18.10	6	10 full.	
122,220	1 3/8	15	6 1/4	4 1/2	112.27	54.72	43.20	41.65	19.13	6 1/4	9	
132,200	1 7/8	15 1/2	6 1/2	4 3/4	120.84	58.27	46.12	45.90	21.61	6 1/2	9 full.	
142,560	1 7/16 full	16	6 3/4	5	130.69	61.84	49.15	52.50	24.44	6 3/4	8	
153,320	1 1/2	16 1/2	7	5 1/4	-	66.03	52.27	56.89	27.42	7	8 full.	

NOTE.-Column 1 is not a standard of strength of cables.

Column 2 is intended to give, as nearly as possible, the size of chains approximating in strength to certain given sizes of wire and hemp rope.

RULES FOR CUTTING AND FITTING HEMP BLOCK STRAPS.

Single Block, with Lashing Eyes. For the length to cut the strap, take twice the round of the block and once the round of the rope, and *marry* the strap once and a half the round of block, and half the round of the rope.

Single Block with Thimble, or Hook and Thimble. Take twice the round of the block, and once the round of the rope. The rounds of the block, thimble and rope, taken once, is the length to marry the strap.

Single Block with Long Strap and Lashing Eyes. Take twice the round of the block, twice the round of the rope, and once the round of the yard. After splicing the two eyes, the length of the strap should be once the round of the block and once the round of the yard; and, after the block is seized in, the length of each leg should be one half the round of the yard. The seizing at the block will take up enough to give sufficient drift between the eyes for lashing.

Single Blocks with Straps to Fid out. Take once the round of the yard, once and a half the round of the block, and once And a half the round of the rope; at the distance of once round the yard, block and rope, marry the strap.

A Single Block with Double Scores, for a double strap. Take twice and a half the round of the block, twice the round of the yard, and once and a half the round of the rope. At twice the round of the yard and block, and once the round of the rope, marry the strap. That which is taken up by the strap passing around the yard, will give sufficient drift between the eyes for lashing.

Double Blocks with Thimbles, or Hook and Thimble, as luff tackles, &c. Cut the strap twice the round of the block, and marry it once the round of the block, once the thimble, and two thirds the round of the rope.

Grommet Straps. One length of rope makes three straps. For a double 10-inch block, 3 1/2-inch rope.

	fm.	ft.	in.
3 times the round of 10-inch block	1	1	0
3 times the round of 8-inch thimble		2	0
3 times the round of 3 1/2 inch rope			10
3 times the round of rope at each end for splicing		1	9
Length to cut the rope for 3 straps	1	5	7
And once round the block		2	4
And once round the thimble			8
And once round the rope			3 1/2
The length to marry the strand		3	3 1/2

And this length is to be marked with chalk on the rope before unlaying.

For a single 6-inch block

	fm.	ft.	in.
3 times the round of block		3	10 1/2
3 times the round of thimble		1	6
3 times the round of rope			7 1/2
3 times the round of rope at each end for splicing		1	3
Length to cut the rope for 3 straps	1	1	3
And once round the block		1	3 1/2
And once round the thimble			6
And once round the rope			2 1/2
The length to marry the strand		2	0

And so on for any size.

If the grommet is made from four-stranded rope, it will only require three rounds of block, three of thimble, and enough to splice and to marry the strand, once round of block and once of thimble.

To Measure for Seizings of Block Straps. Supposing there are to be seven lower, six riding, and three cross turns—measure where the centre turn comes, which take as the average length of one turn, and allow as much for the six riders as the seven lower turns; this will give fourteen turns; then allow for the three crossing turns and splicing the eye, and there will be sufficient end left to heave the last crossing turn on, making seventeen turns in all.

If there are six lower turns, five riders and three cross turns, allow fifteen turns in all, and so on.

If the block is double strapped, allow five turns for crossing each way.

To put a Seizing on the Strap of a Block. It should be well stretched, a few turns taken out and well rubbed down. Splice an eye in one end, sticking the ends once through, but not cut them off. Pass the eye round the strap, reeve the end through it and round the strap, as many times as required for the lower turns; then pass the end underneath the turns and through its own eye, leaving sufficient bight to heave the turns on; place it square round the strap, lay two strands of the splice down the strap, for the seizing to lay over it, heave the lower turns taut on, haul the slack through the eye, and heave it taut; lay the third strand of the splice on top of the lower turns, and pass the riding turns over it, put the end between the two last parts of the lower turns, and put the cross turns on; pass one round turn, which will be the centre one, and heave it well taut; then form a half-hitch on each side of the centre turn, which will form a clove hitch with three parts, unlay the ends, make a wall or crown knot, trim off the ends and it is finished.

A double strap should be crossed both ways; first pass two turns between the strap that faces the side of the block, then bring the end out in the same direction as the sheave, and pass three turns there as before.

Proportions of Blocks to Straps, and to Size of Rope Reeving. For a common thick block, take one third its length for the rope reeving, as a 12-inch common thick block will reeve a 4-inch rope.

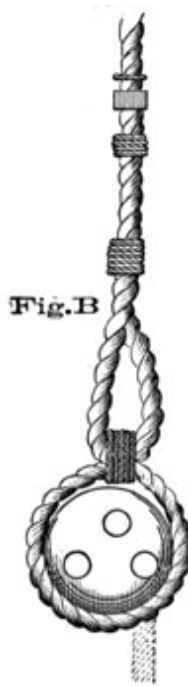
For a clump block, take one half its length.

For a thin block, take one fifth its length. For instance, a 12-inch block should reeve a 2 1/2 inch rope.

For a fiddle block, take one sixth the length of block.

TO TURN IN AN OLD FASHIONED DEADEYE.

In turning in an old fashioned dead-eye in a hemp shroud, the principal caution is to keep the lay in the rope, as it prevents the wet getting in. If the shroud is to be wormed and served in the wake of the dead-eye, the worming should not be hove in too taut, as breaking the shroud round the dead-eye would probably snap it.



The score being well tarred, the end of the shroud is taken underneath, round the dead-eye, inside standing, or mast-head part; a bolt is put in a hole of the dead-eye. Take a good strand, knot both ends together; it is then middled and crossed round the end of the shroud; both bights are taken round the bolt, one on each side of the dead-eye, and a smaller bolt put in each of the bights, which are hove round the large bolt in the dead-eye. As the turns accumulate, it heaves the shroud taut round. The dead-eye should be secured through one of the holes, with spun-yarn, to the shroud before heaving, where the shroud is marked, for the lower part. When the dead-eye is turned in, in a loft, the shroud is hove in with a jigger (or dead-eye machine).

When the shroud is hove well round, pass a good throat-seizing. When secured, take out the bolts, get a smaller jigger, hook one end to a

strap round the end of the shroud, and the other to the mast-head part; take a good strand, knot both ends together, take it round the end and standing or mast-head part; put-a bolt in both bights, and heave it round, pulling up the jigger at the same time; this will bring the end taut up, as heaving on the strap brings both parts close together; then pass a round or quarter seizing, and a smaller one on the end.

In the figures A and B, the quarter seizing is omitted to show the direction taken by the shroud.

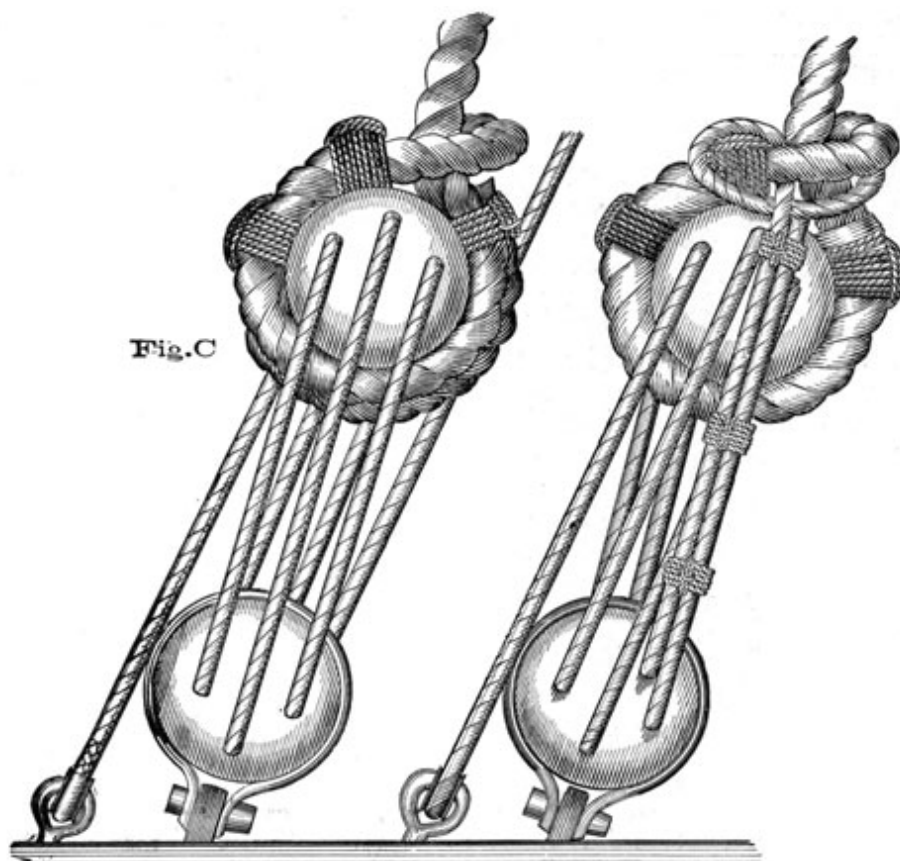
To Turn in Cutter Stay Fashion, Put a temporary seizing on the cross; carry the end round the standing part, and heave it taut alongside its own part; then seize those two end parts together with a throat seizing, making-the eye as small as possible, put a quarter seizing (a flat one) on as well, about

six inches nearer the end; cut the temporary seizing on the cross, open out the clinch, put in the dead-eye, drive the clinch down, keeping the dead-eye with a little cant against the pull of the laniard.

Two seamen should turn in a dead-eye, with 11-inch rope, in a workmanlike manner, in two hours.

The cutter-stay method had its origin, as its name indicates, in the forestays of cutters. As a sail was set on the stay, this plan admitted of its hauling down snugly.

Fig. C is a fair representation of the plan with an improvement in the method of securing the standing part of the laniard by splicing it into an eye-bolt in the channels,



Rigging Screws. There is still another plan of setting up rigging, as represented in Fig. D, by screws. When not to be used, a small iron plate keys on top of the screw, which keeps it from working, and the thread should be thickly smeared with tallow, covered with parcelling and marled. Whenever screws are used, it must be remembered that sufficient end should be turned up to allow it to be turned in afresh after knotting or splicing, in the event of its being shot or carried away. The same contingency should be provided for in all rigging.

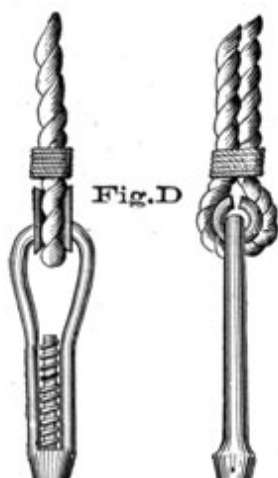
This plan is not considered advantageous in setting up wire rigging, as it makes the whole too rigid.

In the service the use of these (or similar) turn-buckles is confined to places where no give is required, as in the case of chain topping lifts for waist launches.

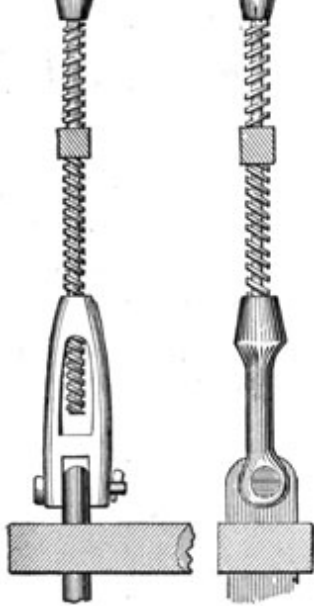
Rule* for Finding the Size of the Fore and Main Shrouds, based on the area, in square feet, of the mainsail, topsail, and topgallant sail.

Rankin, in his work, gives a rule for finding the direct pressure of wind, in

* Book of Allowances, Bureau of Equipment and Recruiting, 1881.



pounds, on the sails, that is, when it strikes them at right angles, as follows: "Divide the square of the velocity of the wind in knots by 150 for the direct impulse on a flat surface in pounds on the square foot." Assuming the velocity of wind in a storm to be 53 miles per hour, and applying this rule of Rankin, the pressure on the sails will be found to be 19 pounds per square foot of surface. Bracing the lower yards at an angle of 35° with the keel, the wind strikes the sails at an angle of 55°. A simple calculation shows that at this angle the pressure is reduced to 15.6 pounds per square foot. Therefore, multiply the area of these sails by 15.6 and the actual angular force exerted will be the result; and this will be the support in pounds required for the mast. Now find the angle of support, or the angle which the shrouds make with the mast. A convenient method is to take a line from a lower dead-eye abreast the mast, and carry it to the centre of the mast horizontally, so as to form a right-angle with it, and measure its length



in feet. Then measure from this point on the mast the distance to the upper side of the trestle-trees. Now divide the length of the line taken from the dead-eye by the above measurement on the mast, and the result will be the tangent of the angle of support. Then to the log. cosec. of the angle of support add the log. of the angular force, and the result will be the power of support required in pounds *for that angle*; but for greater security add one-half of this amount to it, and the result will be the total power of support desired. Divide the total power of support thus obtained by the number of shrouds proposed for one side; the quotient will be the breaking-strain of a single shroud, which seek in the table of strength for the required size. This table is given in Appendix A.

In fore-and-aft rigged vessels, the sail-area used in the computation will be that of the main-sail and main gaff-topsail.

This rule involves the same principles as those of Rear-Admiral T. O. Selfridge, adopted and used by him in the preparation of the allowance tables for 1870.

EXAMPLE. COLORADO AND CLASS.

Area of mainsail	4789 square feet.
Area of main topsail	4178 square feet.
Area of main topgallant sail	1789 square feet.
	--
	10756
	15.6
	--
	64536
	53780
	10756
Angular force =	167793.6 pounds.

609

Log. cosec. 19° 15'	10.48189
Log. 167793.6	5.22477
	--
Log	5.70666
Nat. number corresponding to log. 5.70666 is	508927
Add 1/2	254463
	--
Power of support	763490 pounds.

If we allow 10 shrouds, one shroud will be one-tenth of the total power, which will be 76349 pounds. Corresponding to this number in Appendix A, the size of shroud will be 10 3/4 inches hemp, or 5 inches wire.

NOTE.-The angle of support in this case is 19° 15', that being the mean of the angles of the fore and main, and is taken from the constructor's draught.

APPENDIX D.

STAYING MASTS BY THE USE OF BATTENS.

To guard against the injury which the lower masts of ships have frequently sustained in consequence of the injudicious manner in which they have been stayed and the lower rigging set up, the following suggestions should be of value when fitting out or when setting up lower rigging at any time.

To regulate the setting up of rigging, and to determine if a lower mast is straight, a middle line should be cut on each of its sides and upon the after part. These lines should be painted a different color from the rest of the mast, and extend from the trestle-tree to the heel.

At the upper part of each line a small eyebolt should be placed, and on the line near the deck another such eyebolt. A rope line fastened to the upper one, and rove through the lower, and pulled tight, will, if the mast be straight, coincide with the middle line cut upon it; or, if not straight, the fact will be evident by the cut line and the rope not being parallel. The amount by which parallelism is departed from will represent any curve the mast has taken.

As the lines are to be cut from the heel of the mast to the tressle-tree, by knocking up a side wedge, any curvature that may exist below the wedges may be seen. Consequently, should the rigging be set up with the wedges in, or with them altogether withdrawn, the side lines will afford the means of detecting any bending in the mast, from the crushing tendency of the combined strains upon the stays and shrouds, and of deciding when these ropes should be relaxed.

The middle lines used in conjunction with straight-edged battens present an easy and a safe way of seeing that the mast, when being stayed, is not pulled more than slightly out of the position it is permanently to have.

First, as to the correct athwartship position. If a batten about seven (7) or eight (8) feet long be placed upright on the middle line of the deck, considerably abaft the mast, and its edge can be made to coincide by eye with the middle line on the after part of the mast, the mast will be upright by the shrouds; or, if the edge and the middle line do not agree, the divergence will show to which side, and by how much, the mast inclines.

Second, as to the rake. If a batten standing on the deck, with a rake equal to that which the mast is to have to the deck, be used with the side middle line, and its edge and the middle line coincide, the rake of the mast must be correct; or, if they do not coincide, the direction and extent of their disagreement will show how much the mast is out of place in a fore-and-aft direction.

The rake of the mast has reference to the keel; but as the deck and the keel are not parallel, the angle between their planes must be considered, when

39

610

determining the angle the batten shall have to the deck, in order that it may have the-assigned angle to the keel. This correction may be readily made, and the batten be set at the required angle in a firm base or foot, parallel to the deck.

The lower masts should be placed with such rake as may be shown in the drawings of the ship's original construction, or as may have been subsequently decided as preferable; and in the event of experience rendering it advisable to alter the rake of the masts, every particular relative to the change should be noted in the log-book, and reported in the sailing qualities.

APPENDIX E.

TABLES

Showing the Length, Breadth, and Strength of Flax and Cotton Canvas, as used" in, the U. S. Navy. Together with the Number, Length, and Breadth of Strips cut crosswise and lengthwise, used in the Test of Strength, and the Average Weight required of them, before received for use.

FLAX CANVAS.

Flax canvas to be 20 inches wide, and each bolt to contain 80 running yards. The blue thread in Nos. 1, 2,

3, and 4 to be 1 5/8 inches from the selvage; and in Nos. 5, 6, and 7 to be 1 inches; and in Nos. 8 and 9 to be 1 inch. The warp and filling to be spun exclusively of long, well-dressed, water-rotted flax of the best quality, without any mixture of shorts or tow. The yarns to be evenly spun and of proper fineness; the warp to be rather more twisted than the filling. The warp and filling, from Nos. 1 to 4, inclusive, to be double thread; Nos. 5 and 6 double warp and single filling; and Nos. 7, 8, and 9 single warp and filling.

No description of weaver's dressing, or any pressing or beating to be used in the manufacture.

Three strips to be cut lengthwise and three crosswise will be used to test the strength, each to be 1 inch wide and 20 inches long, except Nos. 8 and 9, which will be 1 1/4 inches wide.

Number of Canvas	Weight per bolt	Weight borne by Strips.	
		Crosswise	Lengthwise.
	<i>Pounds Avoirdupois.</i>	<i>Pounds.</i>	<i>Pounds.</i>
1	84	470	316
2	76	420	280
3	70	370	250
4	64	340	230
5	58	320	216
6	52	300	200
7	46	280	193
8	40	300	200
9	34	280	193

COTTON CANVAS.

Cotton canvas to be 22 inches wide and to contain 80 running yards to the bolt. In Nos. 1, 2, and 3, the blue thread must be 1 1/2 inches from the selvage; in Nos. 4, 5, and 6, 1 1/2 inches; in Nos. 7 and 8, 1 inch; in Nos. 9 and 10, inch; and in the cotton ravens, 7/8 inch, from the selvage. The filling should be stronger than the warp in all numbers. In testing, three strips crosswise and three strips lengthwise will be cut; the strips to be each 1 inch wide and 22 inches long, except in Nos. 8, 9, and 10, which will be cut 1 1/2 inches wide and 22 inches long.

Number of Canvas	Weight per bolt	Weight borne by Strips.	
		Crosswise	Lengthwise.
	<i>Pounds Avoirdupois.</i>	<i>Pounds.</i>	<i>Pounds.</i>
1	90	280	250
2	85	260	230
3	80	240	210
4	75	230	200
5	70	220	190
6	65	210	180
7	60	200	170
8	55	220	190
9	50	210	180
10	45	200	170
Light ravens	30	92	86

APPENDIX F.

ON THE MANAGEMENT OF OPEN ROWING-BOATS IN A SURF.*

I. Rowing to Seaward. As a general rule, speed must be given to a boat rowing against a heavy surf. Indeed, under some circumstances, her safety will depend on the utmost possible speed being attained on meeting a sea. For if the sea be really heavy, and the wind blowing a hard, on-shore gale, an approaching heavy sea may carry the boat away on its front, and turn it broadside on, or up-end it. A boat's only chance in such a case, is to obtain such way as shall enable her to pass, end on, through the crest of the sea, and leave it as soon as possible behind her. If there be a rather heavy surf, but no wind, or the wind off shore and opposed to the surf, as is often the case, a boat might be propelled so rapidly through it that her bow would fall more suddenly and heavily after topping the sea than if her way had been checked.

It may also happen that, by careful management, a boat may be made to avoid the sea, so that each wave may break ahead of her, which may be the only chance of safety in a small boat; but if the shore be flat, and the broken water extend to a great distance from it, this will often be impossible.

* From a pamphlet of the National Life-boat Institution.

612

The following general rules for rowing to seaward may therefore be relied on:

- I. If sufficient command can be kept over a boat by the skill of those on board her, avoid the sea if possible, so as not to meet it at the moment of its breaking or curling over.
- II. Against a head gale and heavy surf; get all possible speed on a boat on the approach of every sea which cannot be avoided.
- III. If more speed can be given to a boat than is sufficient to prevent her being carried back by a surf; her way may be checked on its approach, which will give her an easier passage over it.

II. Running before a Broken Sea, or Surf, to the Shore (Flat Beach). The one great danger, when running before a broken sea, is that of *broaching-to*. To that peculiar effect of the sea, so frequently destructive of human life, the utmost attention must be directed.

The cause of a boat's broaching-to when running before a broken sea or surf is, that her own motion, being in the same direction as that of the sea, she opposes no resistance to it, but is carried before it. Thus, if a boat be running bow on to the shore, and her stern to the sea, the first effect of a surf or roller, on its overtaking her, is to throw up the stern, and, as a consequence, to depress the bow; if she then have sufficient inertia (which will be proportional to weight) to allow the sea to pass her, she will in succession pass through the descending, the horizontal, and the ascending positions, as the crest of the wave passes successively her stern, her midships, and her bow, in the reverse order in which the same positions occur to a boat propelled to seaward against a surf. This may be defined as the safe mode of running before a broken sea.

But if a boat, on being overtaken by a heavy surf; has not sufficient inertia to allow it to pass her, the first of the three positions alone occurs-her stern is raised high in the air, and the wave carries the boat before it, on its front or unsafe side, the bow deeply immersed in the hollow of the sea, where the water, being stationary, or comparatively so, offers a resistance, while the crest of the sea, having the actual motion which causes it to break, forces onward the rear end of the boat. A boat will, in this position, sometimes, aided by careful oar-steerage, run a considerable distance until the wave has broken and expended itself. But it will often happen that, if the bow be low, it will be driven under water, when, the buoyancy being lost forward, while the sea presses on the stern, the boat will be thrown end over end. Or if the bow be high, or protected by a bow air-chamber, so that it does not become submerged, the resistance forward acting on one bow will slightly turn the boat's head, and the force of the surf being transferred to the opposite quarter, she will in a moment be turned broadside to the sea, and be thrown by it on her beam-ends, or altogether capsized. It is in this manner that most boats are upset in a surf; especially on flat

coasts.

Hence it follows that the management of a boat when landing through a heavy surf, must stop her progress shoreward at the moment of her being overtaken by a heavy sea and enable it to pass her. There are different ways of effecting this object:-

1st. By turning a boat's head to the sea before entering the broken water, and then backing in stern foremost, pulling a few strokes ahead to meet each heavy sea, and then again backing astern. If a sea be really heavy and a boat small, this plan will be generally the safest.

2d. If rowing to shore with the stern to seaward, by backing all the oars on the approach of a heavy sea, and rowing ahead again as soon as it has passed to the bow of the boat, thus rowing in on the back of the wave; or, as is practised in some life-boats, placing the after-oarsmen, with their faces forward, and making them row back at each sea on its approach.

3d. If rowed in bow foremost, by towing astern a pig of ballast or large Stone, or a large basket, or a canvas bag termed a "drogue" or drag, made for the purpose, the object of each being to hold the boat's stern back and prevent her being turned broadside to the sea or broaching-to.

613

A boat's sail bent to a yard, loosed and towed astern, the yard being attached to a line capable of being veered, hauled, or let go, will act in some measure as a drag, and will tend much to break the force of the sea immediately astern of the boat.

Heavy weights should be kept out of the extreme ends of a boat; but when rowing before a heavy sea, the best trim is deepest by the stern, which prevents the stern being readily beaten off by the sea.

A boat should be steered by an oar over the stern or on one quarter when running before a sea.

The following general rules may, therefore, be depended on when running before, or attempting to land, through a heavy surf or broken water:-

I. As far as possible avoid each sea by placing the boat where the sea will break ahead of her.

II. If the sea be very heavy, or if the boat be small, and especially if she have a square stern, bring her bow round to seaward and back her in, rowing ahead against each heavy surf; sufficiently to allow it to pass the boat.

III. If it be considered safe to proceed to the shore bow foremost, back the oars against each sea on its approach, so as to stop the boat's way through the water as far as possible, and if there is a drag, or any other appliance in the boat which may be used as one, tow it astern to aid in keeping the boat stern on to the sea, which is the chief object in view.

IV. Bring the principal weights in the boat towards the end that is to seaward; but not to the extreme end.

V. If a boat worked by both sails and oars be running under sail for the land through a heavy sea, her crew should, unless the beach be quite steep, take down her masts and sails before entering the broken water, and take her to land under oars alone, as above described. If she have sails only, her sails should be much reduced, a half-lowered fore-sail or other small head-sail being sufficient.

III. Beaching, or Landing through a Surf. The running before a surf or broken sea, and the beaching, or landing of a boat, are two distinct operations; the management of boats, as above recommended, has exclusive reference to running before a surf where the shore is so flat that the broken water extends to some distance from the beach. On a very steep beach, the first heavy fall of broken water will be on the beach itself; while on some very flat shores, there will be broken water extending four or five miles from the land. The outermost line of broken water, on a flat shore, where the waves break in three or four fathoms of water, is the heaviest, and therefore the most dangerous; and when it has been passed through in safety, the danger lessens as the water shoals, until, on nearing the land, its force is spent and its power is harmless. As the character of the sea is quite different on steep and flat shores, so is the customary management of boats, on landing, different in the two situations.

On the flat shore whether a boat be run or backed in, she is kept straight before, or end on to the sea until she is fairly aground, when each surf takes her further in as it overtakes her, aided by the crew, who will then generally jump out to lighten her, and drag her in by her sides. As above stated, sail will, in this case, have been previously taken in, if set, and the boat will have been rowed or backed in by the oars alone.

On the other hand, *on the steep beach* it is the general practice, in a boat of any size, to sail right on to the beach, and in the act of landing, whether under oars or sail, to turn the boat's bow half round, towards the direction in which the surf is running, so that she may be thrown on her broadside up the beach, where abundance of help is usually at hand to haul her as quickly as possible out of the reach of the sea. In such situations, we believe it is nowhere the practice to back a boat in stern foremost under oars, but to row in under full speed, as above described.

APPENDIX G.

MISCELLANEOUS ROUTINE.

Monthly Routine.-On first Sunday in month, read Articles of War.

On first week-day in month, officers of divisions inspect clothing, see them properly marked with name of the owner, and make out list of clothes.

On first week-day in month, at evening quarters, each man will muster with his hammock, and officers of divisions will inspect the bedding.

On the twelfth of the month, serve out small stores and make out requisitions for clothing.

On the fifteenth of the month, issue clothing. If these days fall on Sunday, issue the following day.

On the first day in month, the midshipmen will send to the Captain for inspection their journals, watch, and station bills.

On first Thursday in month, scrub hammocks.

On second Thursday in month, wash blankets.

At a suitable time during the quarter, overhaul cables and shot lockers.

Half-Monthly Routine.-First and third Tuesdays, air bedding. Second and fourth Tuesdays, scrub mattress covers.

Second and fourth Wednesdays, scrub windsails, etc.

First and third Fridays, scrape masts.

Second and fourth Saturdays, overhaul and mark clothing.

Daily Routine-In Port.-Early daylight. Reveille: Call warrant officers and mates of decks ten minutes before. Call all hands, allowing twelve minutes to clear decks of hammocks, lay up rigging and sweep clean, pump ship out, wipe off paint-work, clean boats, clean ship outside, wash down, clean copper, place wash-deck gear to dry and square yards.

7:30 A.M. Inspect servants and boys.

7:45 A.M. Mate of berth-deck reports deck ready for breakfast.

7:50 A.M. Spread mess-tables.

8:00 A.M. Colors, breakfast, light smoking lamp, crew dress for the day, report chronometers wound.

8:45 A.M. All hands, out smoking lamp, clean gun bright-work, quarter gunners spread tarpaulins and get out cleaning rags, sick call.

9:00 A.M. Down wash-deck gear if dry, down all ditty boxes and clothes bags.

9:15 A.M. Knock off bright-work, clear up decks for quarters, sweep clean.

9:30 A.M. Quarters for inspection; drill as per routine.

11:30 A.M. Flemish down rigging aft if deck is dry, clean sweep down, ship's cook bring dinner to the mast.

11:45 A.M. Mate of berth-deck reports deck ready for dinner.

11:50 A.M. Spread mess-tables.

Noon. Dinner, light smoking lamp.

1:00 P.M. Turn to, out smoking lamp, sweep clean.

2:00 P.M. Serve Jut provisions.

4:30 P.M. Lay up rigging, sweep down.

4:45 P.M. Mate of berth-deck reports deck ready for supper.

4:50 P.M. Spread mess-tables.

5:00 P.M. Supper, light smoking lamp, shift in blue, get out dirty clothes if the routine is to wash clothes next day.

5:30 P.M. All hands, out smoking lamp, sweep down.

Ten minutes before sunset. Get clothes line ready for tricing up.

Sunset. Colors, up boats, up wash-deck gear, trice up clothes line when colors come down, evening quarters.

After Quarters. Pipe down hammocks, after hammocks light smoking lamp.

9:00 P.M. Tattoo, sound call at 8:50 P.M., pipe down, crew turn in and keep silence, set anchor watch.

615

MONDAY.-Scrub clothes, scrub decks, ladders, etc., with sand.

TUESDAY.-Scrub decks without sand.

WEDNESDAY.-Scrub clothes and holystone decks.

THURSDAY.-Scrub spar-deck without sand, ladders, gratings, boats' oars and masts with sand.

FRIDAY.-Scrub clothes, scrub boat awnings, mess cloths, etc., scrub decks with sand.

SATURDAY.-Holystone decks, ladders, and gratings, and scrub bright woodwork with sand and canvas.

SUNDAY.- Scrub decks without sand, and prepare for inspection. MONDAYS.-Examine and sign

yeoman's weekly accounts.

FRIDAYS.-Clean out galley funnel.

At Sea.-5:00 A.M. Call idlers, lay up rigging and sweep clean, scrub clothes except on Sunday, execute morning orders, place wash-deck gear to dry, see all snug aloft, etc.

7:00 A.M. Call all hands, allowing ten minutes to clear decks of hammocks, serve out tea water, up ashes, if steaming.

7:15 A.M. Master-at-arms inspects servants and boys, mate of berth-deck reports deck ready for breakfast.

7:20 A.M. Spread mess-tables.

7:30 A.M. Breakfast, light smoking lamp, crew dress for the day.

8:00 A.M. Relieve watch, wheel and look-out, report chronometers wound.

8:30 A.M. "Turn hands to," clean gun bright-work, out smoking lamp.

9:00 A.M. Sick call, put away all pea-jackets, ditty and clothes bags, down wash-deck gear, if dry; clear decks for quarters.

9:30 A.M. Quarters for inspection, drill as per routine, after drill watch below to have their bags.

11:00 A.M. Up ashes, if steaming.

11:30 A.M. Call Navigator, lay up rigging, sweep decks, clean out spit-boxes, ship's cook bring dinner to the mast.

11:50 A.M. Spread mess-tables.

12:00 M. Report latitude to commanding officer, dinner, light smoking lamp.

12:30 P.M. Relieve watch.

1:00 P.M. "Turn hands to," out smoking lamp, sweep decks, pipe down wash clothes, if dry; otherwise at 3:30 P.M.

1:30 P.M. Sound call for provisions.

3:00 P.M. Up ashes, if steaming.

3:30 P.M. Lay up rigging, sweep down, etc., serve out tea water.

3:50 P.M. Spread mess-tables.

4:00 P.M. Supper, light smoking lamp, shift in blue.

5:00 P.M. "Turn hands to," out smoking lamp, coxswains report breakers of water in boats.

Sunset. Evening quarters.

Immediately after sunset. Serve out pea-jackets.

Fifteen minutes after sunset. Pipe down hammocks, light running lights, light smoking lamp, up wash-deck gear and clothes lines.

8:00 P.M. Call the watch, out smoking lamp, muster the watch, see life-buoys in order and life-boats ready for lowering.

Night look-outs to be stationed at dusk, and called down at daylight. A man on the fore-topsail yard when look-outs are not stationed. A man always to be stationed at life-buoy, night and day. When square-sails are set, men always at the halliards. Muster watch and life-boat crews at eight bells.

The above routine is given subject to the approval of the commanding officer. The times will have to be modified to suit the season of the year, and the station to which a vessel is attached.

Preparing Ship for Sea. Gun divisions are sent to quarters and the battery secured for sea.

The officer of the fore-castle will see to the following: Lower booms rigged.

616

in and secured; riding chain brought to, if in a single-deck ship, cat and fish fall rove; tacks and sheets hooked; studding-sails bent and gear rove; covers off head sails, chafing gear put on.

The officers of the gangways will see to the following: Riding chain brought to the capstan, if a single-deck ship; that carpenters unship accommodation ladder; studding-sails bent and gear rove, chafing gear put on, covers off trysail, tacks and sheets hooked.

The officer of the quarter-deck will see to the lowering apparatus on lifeboats, all davits rigged in and boats secured for sea, chafing gear put on, etc. Coxswains of boats and two boat-keepers will suffice for securing boats.

In addition to these preparations made just before getting underway, the following duties are to receive attention in good season before putting to sea;

The navigation officer should see that the compasses, timepieces, sandglasses, and log, have been verified, and that they and the chronometer are kept in their proper places and have a free motion. That the chronometers are well regulated, the rate known before sailing, and are regularly attended to. That everything belonging to the cables, such as the stoppers, hook-ropes, compressor-tackles and blocks, are ready for use. That the shackle-pins for the chains are kept well white-leaded, in order that the chains may be easily unshackled. That the vessel's draught of water be taken immediately before getting under way, and that hand leads and lines, properly marked and fitted, are placed in the channels abreast the mainmast. That the deep-sea lead and line are properly fitted, the latter being on a reel or in a tub; and, if a patent apparatus, that it is thoroughly understood and in good working order. He should see the tiller-ropes properly attended to and examined in port and at sea to detect chafes. If they are of raw hide, they should be occasionally oiled.

The *boatswain* should see that the masts are upright, well stayed and greased, head booms well supported, yards square, lifts marked, heels of booms square and toggled ends, equally rigged out, gaskets passed square and at equal distances, ropes clear for running on deck and flemished down in the tops. The ends of all running rigging neatly hitched or pointed, square and "sharp up" marks on all braces. New topsail halliards well stretched and re-rove that they may not become cable-laid when making sail.* He should see that the hawsers and towropes are so stowed that their ends may be passed up from the reels at any moment. Preventer braces, hammock girtlines and clothes lines in order, stern ladders in place and fitted with life lines. That ropes likely to unreeve in a squall, such as the main and jib-sheets, have an overhaul knot in the end.

Besides the square mark on the braces, it is well to have a mark on the jib and spanker sheets, as they are frequently trimmed too flat.

He should see that the laniards of the rigging are good, that the dead-eyes, and ends of the shrouds are square. That the purchases, winding and rolling tackles, preventer-shrouds, storm-sails and gear, including relieving tackles, are fitted and at hand. That the running rigging all leads fair, and that mats, raw hide, scotchmen, and timenoguys, are placed about the rigging and yards, wherever they may prevent chafes and fouling. He should see that the ratlines of the lower and topmast rigging are trustworthy and square, and that defective ones are instantly replaced by new, so that the men may go aloft with confidence. That each top is supplied with a top-maul, secured by a laniard; and a small top-chest to contain marlinspikes, stoppers and jiggers. That stoppers are-prepared and ready to be applied to the braces, sheets, halliards,

etc., wherever they are belayed; and that the captains of the fore-castle, masts, and tops, have always at hand jiggers to be applied to any rope when necessary. That chain slings for the yards and gaffs are properly fitted, and at hand for instant use.

The gunner should see that the whole apparatus for securing and working the guns is complete, handspikes, port laniards, muzzle bags and lashings, priming

* The lower block of the topsail halliards should have a swivel hook for clearing when cable-laid.

617

wires, boring bits, rammers, sponges, side and in-tackles, and port bucklers, and that the breechings are good and well fitted. That the fire buckets are fitted with laniards and kept in their proper places. When powder is on board, he should see that there are a certain number of cartridges filled, not only of full but of reduced charges. That the shot are properly stowed as well as all the torpedo fittings and torpedoes.

That the arrangements for flooding the magazine are complete and in working order. That the armory and shell room are dry and properly stowed, shell whips fitted and in place, chutes, etc., made in accordance with Ordnance instructions, and proper care taken of the small arms.

In addition to the ordnance stores, the gunner has special charge of the anchor buoys and life buoys, to see that they are in good order, and the latter ready for use at all times. He examines and primes the life buoys every evening, and reports their readiness to the officer of the deck.

The sailmaker should see that the sails bent are properly brought to the yards and gaffs; that every roband is well secured, and that the head and reef-earings are good, and all arrangements for reefing in thorough order. That the spare sails, properly fitted with robands, bowline bridles, head and reef-earings, buntline b toggles and reef cringles are made up, tallied and stowed conveniently in the sail-room; that each studding-sail has its appropriate cover, and that all sail covers, boats' sails, wind-sails, awnings, hatch-covers, hammock cloths, etc., are on board.

The carpenter should see, previous to sailing, that the rudder is well hung and free in its movements, and that pieces to make a spare one are on board, and at hand in the hold. That the capstan and its fittings, bars, swifterns, etc., are in good working order, and spare spars properly cared for. He should see that the spare tiller fits, and is at hand ready for use; that the relieving tackles are in their places; that the air ports and lower deck ports are well lined and secured in, or that the apparatus for closing them is always within reach, and ready for immediate use; that the bilge and force pumps are in good order. He himself, or one of his assistants, ascertains at least every hour, while at sea, and every morning and evening in port, the quantity of water in the vessel. He should see that all the pump gear and the sounding rod are always kept in their proper places; that the lightning conductors are in good order; shot plugs ready for use; that the tarpaulin covers for the hatches are in a good state, and he should be always ready with gratings and battens for the hatches. He should see that there is an axe at each mast ready for use in cutting away spars or rigging.

Before leaving port and upon entering it, the carpenter is always to take the ship's draft.

The *executive officer*, in addition to his general supervision over all preparations, should see that equipment, construction, and other stores and water are on board in accordance with the requisitions made and approved, and that they are properly stowed where they belong, that they are entered on the log and books of the yeoman or others in charge of them, and that the expenditure of articles in the general store-room is properly accounted for; that the general store-room is properly regulated, so that any article required may be instantly obtained.

After the boats are in, he should see that they are properly stowed, and that they, the galley, spare spars, anchors, and everything that may be affected by the rolling and pitching of the vessel, are well secured. That there are stretchers in all the boats, and that one of the quarter or stern boats is always kept in readiness to be lowered at short notice. That the plugs of the boats are secured near the plug hole by a good laniard, and a line from well forward in the forechains secured to the ring-bolt in the bows. That at least one of the outside boats is fitted with a lowering apparatus, and that each one has a breaker of water and their gripes fitted with slips. That the fittings of all boats are thorough for any service.

station and duties, for action and for evolutions, and with his berth and mess and that the ship herself is in all respects prepared for battle.

APPENDIX H.

TARRING DOWN, SCRAPING SPARS, PAINTING SHIP, &c.

Black down, and as soon as the blacking is dry, scrape and grease spars, and paint ship, in the order named. If intending to coal ship, do that first of all.

It is customary in some ships first to scrape masts, then tar down the rigging, and lastly paint; but the men are liable to daub the masts when tarring, down.

To prevent spotting the deck. Wet down and sprinkle liberally with sand. This prevents the grease or tar from striking in, and is better than keeping a couple of inches of water on deck by closing the scuppers, as the oily matter in that case floats to the water-ways and soils the paint work there.

Mixture for blacking down. By measure, two parts Stockholm tar, one part coal tar, one part tar oil. This is for rigging which has been neglected for some time. To give a light coat, thin the above with additional tar oil, to suit.

Scraping and greasing spars. When the blacking of the rigging is dry, the masts ought to be scraped and cleaned, then greased. For the men to stand upon when scraping the lower masts, rig triangles of capstan bars, with whips to the mastheads; for hoisting and lowering, with the topmasts, handspikes answer instead of capstan bars, and the royal and top-gallant masts may be managed from a bowline in the end of a girtline, or a span from shroud to shroud.

The top-gallant and royal yardarms should not be neglected. The studding-sail booms, except when new, ought to have the least possible shaving taken off them by a carpenter, and then varnished. This does not injure them more than scraping, and keeps them smoother.

Before laying on the grease, the captains of the tops should report that everything is scraped and ready, and the boatswain should examine.

Studding-sail booms should never be greased, as they are liable to soil the sails.

Painting Ship.* White lead is the principal ingredient in all ordinary colors used in painting; the quality is therefore of the greatest importance. The cheap kinds are adulterated by "byrates," which cause them to be more easily acted upon by the atmosphere. In mixing, the oil and turpentine should be thoroughly incorporated with the white lead. If adulterated, the white lead will have poor body when mixed.

ZINC WHITE is more durable than white lead; it is pure, but possesses little body.

VEGETABLE BLACK is the cheapest and best black for all ordinary work. In a dry state it resembles soot, and being free from grit does not require grinding. It should be mixed with boiled oil.

LAMPBLACK is allowed in the service for ordinary ship's use.

VERMILION in a state of powder may be tested by placing the dust of it on a piece of clean white paper and crushing it with the thumb nail. If pure it will not change color by any amount of rubbing, but if adulterated it will become a deep chrome yellow or assume the appearance of red lead, with which article it is mixed in order to cheapen it.

BLUE.-The most serviceable blue for the painter is French ultramarine. It may be deepened by Prussian blue or indigo, or by a trifling addition of vegetable black.

Mixing Colors. CREAM COLOR. Chrome yellow, the best Venetian red and white lead.

*Bedford. For additional recipes, &c., see Qualtrough's "Sailor's Handy Book."

619

SALMON COLOR. White lead, tinged with the best Venetian red, or burnt sienna.

IMITATION OF GOLD. Mix white lead, chrome yellow, and burnt sienna till the proper shade is obtained.

Proportions of Materials for Mixing Paint.*

BLACK:-

100 pounds of lamp black, in oil,
5 gallons linseed oil, raw,
5 gallons linseed oil boiled,
1 gallon turpentine,
1/4 gallon Japan drier.

One pound will cover about five square yards of surface.

WHITE, FOR INSIDE WORK:-

100 pounds white lead, in oil,
4 gallons turpentine,
1 pint linseed oil, raw,
1/2 gill Japan drier,

One pound will cover about three square yards.

WHITE, FOR OUTSIDE WORK:-

100 pounds white lead, in oil,
1 gallon turpentine,
3 1/8 gallons linseed oil, raw,
1/2 gill Japan drier.

One pound will cover about one and a half square yards.

STRAW COLOR, FOR SPARS:-

100 pounds white lead, in oil,
25 pounds yellow ochre, in oil,
2 pounds Venetian red, in oil,
2 ounces Vermilion.

One pound will cover about one and a half square yards.

SHELLAC, FOR DECKS:-

1 1/2 pounds of gum shellac,
1 gallon of alcohol.

NOTE.-The above are general allowances. The actual quantities used must depend upon the character of the material and of the work. Generally speaking, the purer the coloring matter the greater thinning it will bear, and if the surface to be painted is very rough or old it will need more oil than new work.

COPPER COLOR PAINT. Six parts spruce ochre, one part Venetian red, one part black.

REMOVING OLD PAINT. Nothing is so efficacious as heat, applied by a small brazier with a handle.

One part of pearlash mixed with three parts of quick stone lime (by slaking the lime in water and then adding pearlash) laid over paint work and allowed to stand 14 or 16 hours will soften it so that it can be easily scraped off.

GILDING. Books of gold leaf contain 25 leaves. Gilders estimate their work by the number of "hundreds" it will take (meaning one hundred leaves) instead of the number of books.

The simplest way to use gold leaf is as follows Procure a clean sheet of silver or tissue paper of not too great density, and rub it over lightly on one side with a piece of white wax. The paper should be placed on something flat, so that the wax is spread evenly.

After waxing a sheet of paper it should be cut into squares a little larger than the leaves of the book of gold, which should be opened and the waxed side of the tissue paper gently pressed on the gold leaf. On removing the paper the gold leaf will be found attached to it and it is ready for use. All that the gilder

* Allowance Book, Bureau Construction and Repair, 1881.

620

has to do is to cut it into convenient strips and press it on the sized surface, when the gold will readily leave the paper. The work should be finished by gently dabbing it with a pad of cotton wool.

Gilt work exposed to the weather lasts much longer if it receives a coat of clear varnish when finished.

SIZE. If unprovided with regular gold-size, mix chrome yellow with the fat oil from the surface of paint that has been standing, and add a very small quantity of dryer to form a moderately thick coat. Apply the leaf when the size is "tacky" enough.

In estimating the amount of gold leaf required for gilding ordinary grooved moldings around boats, &c., one leaf covers about nine running inches.

APPENDIX I.

IN A TIDEWAY UNDER SAIL.

DRIFTING-CLUBBING-BACKING AND FILLING.

IN drifting or working down a river, with a strong tide, great care is necessary to prevent falling afoul of other vessels which may be at anchor on the way, or to avoid endangering the vessel on rocks or shoals.

With the wind directly in the harbor, or partly across the tide, the current running out, you may either *work* out by tacking from shore to shore; let her *drift* out broadside to the current; or, having her under the direction of the helm, by sufficient sail set to give her good way through the water, keep her head to the current, and drift down stern on, or you may *club* her down.

Bear in mind, in every evolution performed in a tideway, that the after part of the keel being more deeply immersed in the water, and presenting a broader surface to the action of the current than the forward, the stern of a vessel will always have a tendency to drift faster than the bows.

If the wind should be partly across the tide, she should be cast, in getting under way, with her head towards the weather shore.

After getting under way, which is sufficiently explained in CHAPTER XXII., keep her head to the current, by sufficient sail, until the anchor is catted and fished.

Never weigh the anchor until the sails are so arranged that the vessel will be immediately under the influence of the helm.

If you have room, you may then proceed to bring her by the wind, make sail, and work her down as in the common evolution of working to windward, making an allowance for the strength of the current, in approaching any vessel, or either shore, and in giving yourself sufficient room for stays.

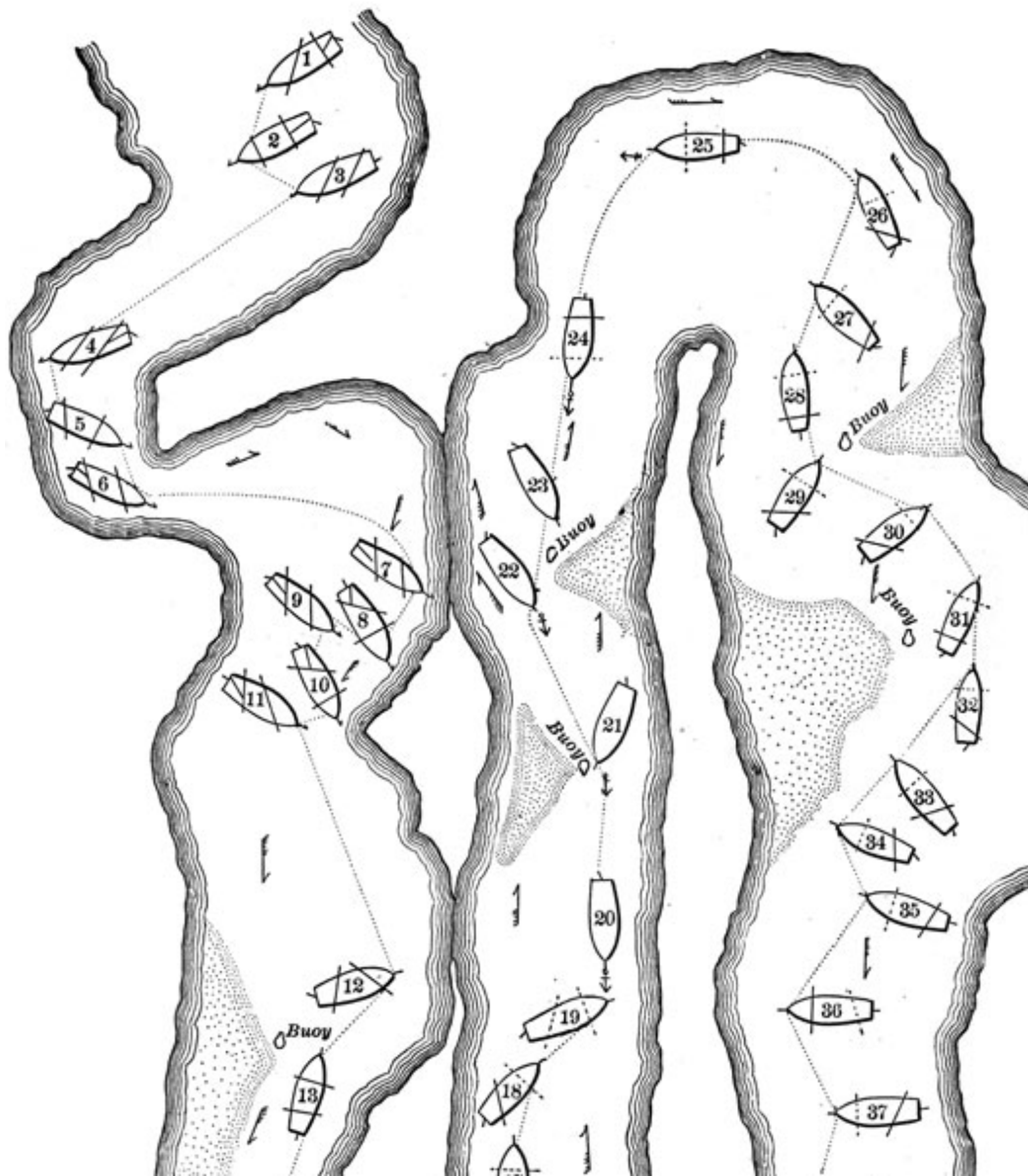
Should the wind be across the tide, you may approach the weather shore boldly; for should you miss stays, you have recourse to wearing or box-hauling. But approach the lee shore cautiously, always leaving room to recover her and gather headway, to go in stays a second time.

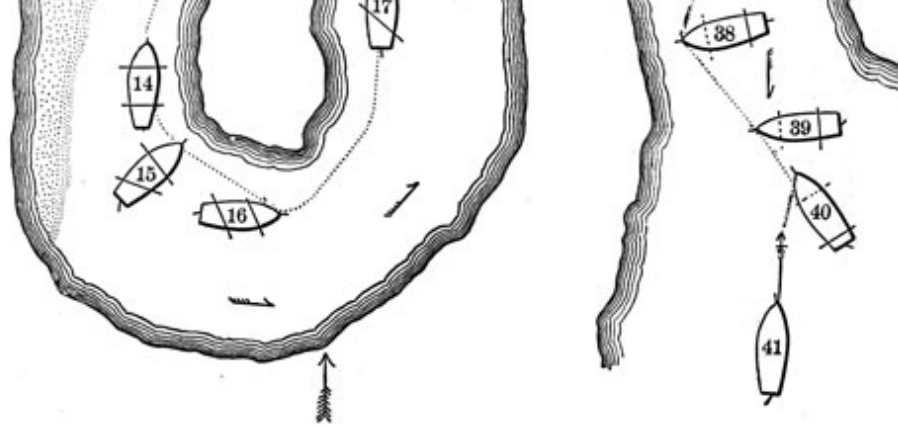
Avoid standing into eddy currents on either shore; they may be plainly distinguished by the worried appearance of the water; for a vessel, when in their influence, is at their mercy, and quite out of the management of the helm or sails.

If you approach a narrow passage, or the anchorage of a number of vessels, bring her head to the current, bracing the yards full, and keeping only sufficient sail on to give her good steerage-way through the water, that you may sheer her to either side; and in this manner she will drift down with the current, past or between any vessel or shoals. This is the best, being the safest method for a narrow channel.

Arriving again at an open space, you may bring her broadside to the current, keep the topsails shaking and the helm a-lee, and presenting only the surface of

Plate A





the spanker to the wind, which will serve to counteract the force of the current Upon the stern. In this manner she will drift more rapidly than by the former method. By filling the head yards and taking in the spanker; or by filling the after yards and taking in the jib; or by bracing all aback, using the helm as necessary, you can, at any time, have her under control, shoot ahead, back astern, or bring her head to the current.

Clubbing. Clubbing is recommended for smaller sailing vessels in a rapid river; you may heave in the cable until the anchor is under foot, when she will drift down by the force of the current, veering out or heaving in the cable as she deepens or shoals the water, or as you may wish to diminish or increase her drift. Vessels drifting in this manner, generally have a spring from the ring of the anchor, leading in at one of the quarters, so that by veering on the cable and rousing in the hawser, you may present her broadside to the current. This is termed *clubbing* a vessel.

Clubbing is such a simple manoeuvre, where the sets of the tides are known, that it is only necessary to observe that a ship at anchor, with a tide running past her, is as much affected by a motion of the helm, as if she were reaching at the same rate under canvas; therefore, if a ship's helm be put over one way or the other, she will answer it, and shoot across the tide, taking her anchor with her, if there be short enough scope, so by heaving in to that scope, and putting the helm hard over, she will cross the tide without losing much ground; hence, although the tide may set athwart the deep water channel, yet by sheering her as far as she will go, and bringing her up when she begins to lose ground, she may be dropped down, or sheered across any channel against the wind, where she might otherwise wait months for a fair wind to sail down. It is scarcely necessary to observe, that she will sheer to port more readily with her starboard anchor down, and *vice versa*.

Backing and Filling. Before steam-tugs were so plentiful, vessels relict! upon the tides, in many instances, to get them to sea.

You may drift a vessel down broadside to the current, keeping the yards counter-braced as in lying to, shooting ahead, or backing astern to avoid danger; then, as you approach either shore, you may fill away until she gathers sufficient headway for stays, or wear around, putting her head towards the other shore, this is termed *backing* and *filling*.

To do this properly, a knowledge of the times and sets of the tides, depth of water, eddies, etc., and especially a correct judgment of distance, are of the first importance.

To give a clear idea of the various manoeuvres, and show what can be done with a ship without steam, a sketch (Plate A) is given of a vessel backing and filling up a narrow channel, with the wind and tide in every possible different position with respect to each other.

The wind and sets of the tide are designated as before by arrows and half arrows, and the vessel's track or course by the dotted lines from number to number. No. 1, Plate A, represents a vessel reaching the tide with her main yard aback to avoid reaching too fast; proceeds to No. 2, having reached out of the strength of the tide, has thrown her fore yard aback, and is making a stern board, by which she will fetch No. 3, fills and reaches to No. 4, tacks, the tide sweeping her while in stays round the point, but not sufficiently soon to enable her to fill on the starboard tack; the fore yard therefore kept aback, as in No. 5, while the

tide is setting her to No. 6, fills; the tide in this reach setting to leeward, she does not make a weathery course until she meets it running to windward again, when she reaches to No. 7, where the helm is put a-lee and the main yard swung, and she shoots into the position of No. 8, is not permitted to come round, but falls off again, and makes a sternboard to No. 9, fills and reaches ahead as far as she can, then repeats the manoeuvre of No. 7 to No. 10, whence, as before in No. 8, she makes a sternboard to No. 11, where she is in a "fair way," and will maintain her position in the strength of the tide, by backing, filling, or shivering the main yard, or both, till the tide sets her into the

position of No. 12, where she is being brought astream of the tide, to drop stern, first under better command, through a channel which is too narrow to allow her to drop athwart.

From No. 11 she might have reached into the bight, and tacking there, have fetched as far to windward as No. 13; but there being an eddy tide in the bight, she would perhaps have lost half the tide before she got out of it again, unless she had a commanding breeze.

No. 13, being astream of the tide, is dropping through the narrow channel to, No. 14, and thence to No. 15, where she is hauling her wind on the starboard tack to No. 16, in a "fair way" to No. 17, where the tide is setting to leeward, and the fore-topsail is clewed up, as she is going to bring up, there not being sufficient water for her to proceed; the main yard is therefore braced up to take-aback, that when she rounds to, as in No. 18, she may not shoot across on to the opposite bank.

No. 19, the main-topsail being clewed up or down, the anchor is let go, and the vessel swings head to wind and tide, as in No. 20; having to wait a short time here till there is sufficient water for her in the next channel, the jib-boom is rigged in and the fore-topsail furled, as she is coming to a more crowded part of the river, and does not require to reach any distance. When there is sufficient water for her to proceed, known perhaps by the time of tide, or by the water she is riding in, or if it be a shifting channel by a boat stationed there, the cable is hove in and she clubs to No. 21, where she is sheering across the channel to No. 22; the tide here setting into the bight, she is obliged to sheer broad to port to prevent her being set in there.

No. 23, the helm aport to bring her astream again, clubs to No. 24, has got the main-topsail set again to help her to No. 25, wind abeam, main-topsail shivered, or backed as required till she arrives where the tide is setting to windward, as in No. 26, heaves up and drops, filling or shivering the main yard, to No. 27, clear of the buoy, is brought astream again, as in No. 28, and dropped to, No. 29, hauling her wind to cross the tide, as in No. 30, where the main-topsail full prevents the tide from setting her up on the sand astern, when she fetches. No. 31, is again brought astream and drops to No. 32, where she is again laid athwart and drops fore-reaching a little with her main yard full, as in No. 33, and thence to No. 34, where the main yard is laid aback for a stern board to No. 35, whence, by backing, filling, or shivering the main yard, either to keep in the best of the tide, or to make way for other vessels passing up or down the channel, she arrives as in the following figures at No. 39, where she is again laid astream and the main-topsail clewed up, as in No. 40, where she can drop her anchor and ride-to windward or to leeward, according to circumstances.

APPENDIX K.

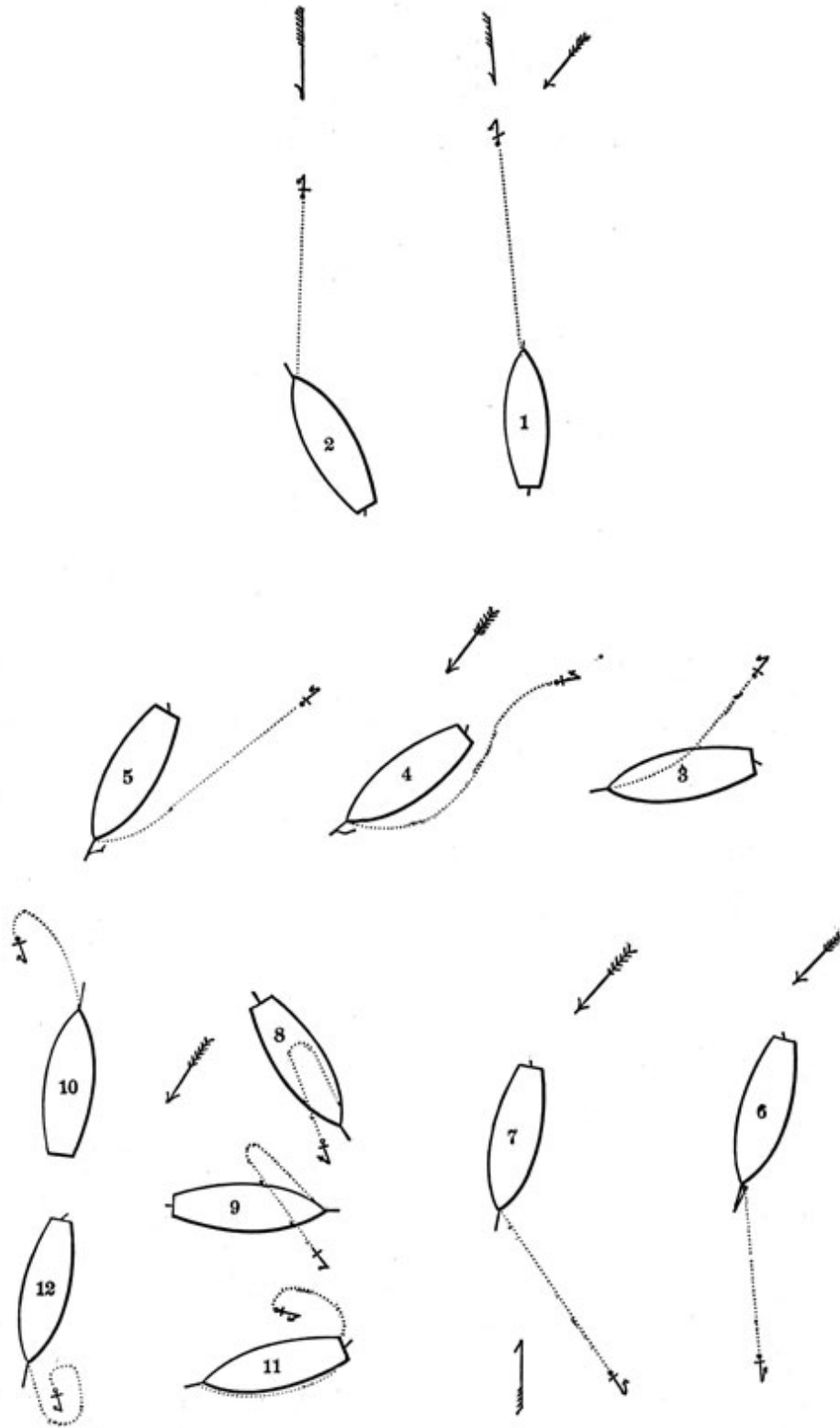
TENDING SHIP AT SINGLE ANCHOR.-FIRE BOOMS.

Tending ship is the art of keeping an anchor clear. When hemp cables were used this was a necessary precaution, the neglect of which rendered the cable liable to foul the anchor at each turn of the tide. The object to be attained, is, to keep the cable taut, and to sheer the ship on the same side of her anchor every time she swings, and keeping her as much as possible away from the anchor.

With chain cables there is not the same necessity for tending ship, as the vessel will probably ride by the bight of her chain in light winds if she has a good scope out, and will not approach her anchor.

The tide being supposed in these cases stronger than the wind, we see that after the weather flood makes, the ship will probably ride to leeward of her anchor by the bight of her chain; if now the breeze freshens and becomes stronger

Plate B



than the tide she will probably swing round, still being to leeward of her anchor.

By always sheering the ship on the *same* side of her anchor we insure its turning in the ground, and avoid fouling or tripping it.

In tending ship we make use of the helm, jibs and spanker. An officer understanding the effect of each, will find no difficulty in keeping the ship away from her anchor, and sheering so that she will tend to the same side of it at each turn of the tide.

Riding to Leeward in Moderate Weather. A deep ship will ride best to windward of her anchor, because she has more hold of the tide and less of the wind; for the opposite reason, a light ship will not ride to windward at all.

No. 1, Plate B, represents a vessel riding out the lee tide in moderate weather, with about thirty fathoms chain cable; square yards and her helm amidships.

NOTE.-In all weathers a ship should be kept to leeward of her anchor, so long as she will ride so.

It is intended to ride to leeward on the next or weather tide, therefore when the present lee tide eases, put the helm hard a-starboard, which will give her a sheer to leeward, as in No. 2.

When the tide is done she will thwart, and ride with the chain slack under foot. This is the time to *sight the anchor*. No. 3.

The helm is now of no service, so shift it hard a-port and hoist the fore topmast-staysail with the port sheet aft; the wind being on the starboard quarter, the staysail will help her away from her anchor until the weather tide makes, when she will swing to the bight of her chain, and bring the staysail aback, as in Nos. 4 and 5; and as the tide gains strength she will gradually drop astream of her anchor until it rides, as at No. 6, when the helm must be eased as the tide attains its full strength, and lashed a few spokes a-port the whole tide; if the stream be not sufficiently strong to keep a taut cable, she will require the staysail. set all the tide, otherwise she will not ride quiet; the relative strength, therefore, of wind and tide will determine when it is required.

When the weather tide is nearly done, put the helm hard a-port, which will give her a broader sheer to leeward, as in No. 7.

This is called *tending to windward* or *tending to a weather tide*.

When the tide changes, the wind remaining the same, say northeast, we must again go to the westward of the anchor. To do so give her a sheer with the port helm just before the tide ceases, and hoist the staysail; she will then, as the tide slackens, forge ahead and thwart as before, when the helm must be shifted and the staysail hauled down; she will then drop astream of her anchor, and ride as at No. 1.

It will make no difference whether the ship swings with her head towards her anchor or not; all we wish is to keep her away from it. This second operation is called *tending to leeward*, or *tending for a leeward tide*.

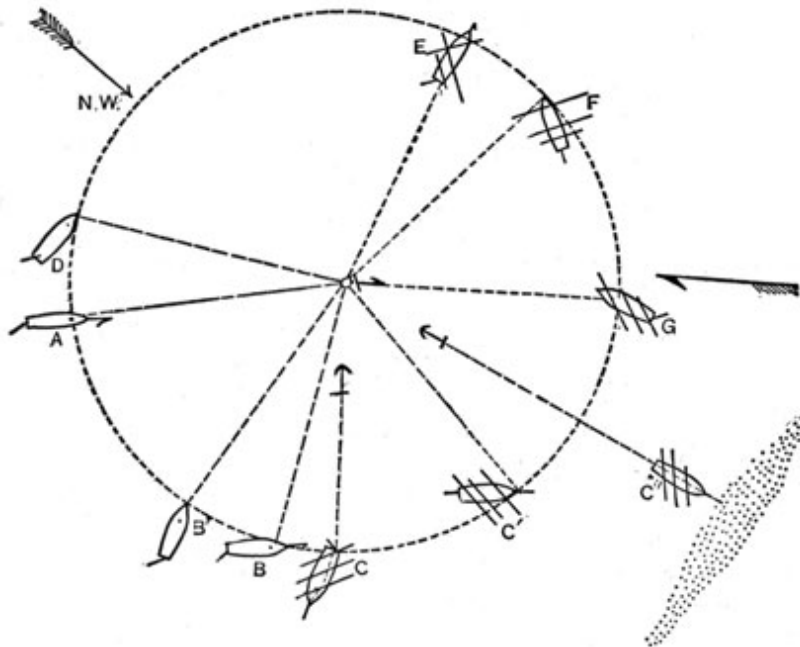
If left at No. 6 to swing herself, her first movement, as the tide eases and becomes weaker than the wind, would be to forge ahead (the wind being abaft the beam), dragging the bight of her cable with her, as in No. 8; and as she thwarts, the yards being full and a drain of tide under her lee, she will shoot a little across the tide and swing with the bight of her cable on the weather side of the anchor No. 9. This on the next tide becomes a round turn, see No. 10, &c., as she cannot possibly return the way she came without assistance.

The result is a foul anchor, the chain taking a turn around the upper fluke. A fresh squall now strikes the ship, and straightens out her chain; the strain coming on the upper fluke, the anchor is tripped, and away goes the ship, fouling some of her neighbors, getting on shore, or bringing up in some out of the way place by a second anchor, or else, by continued neglect (Nos. 11 and 12), the entire scope is expended around the anchor.

Riding to Leeward in Heavy Weather. Suppose, in the diagram, the wind to be N. W., and the ship

east, as at A. If now the wind freshens, the ship will lie uneasily, and will be continually yawing about. Hoist the staysail to steady her; but should the wind freshen so as to force her into the position B, haul down the staysail and set the spanker, to prevent breaking her sheer and walking off with her anchor. By hauling down the staysail and setting the spanker, we keep her in the position B', where she will ride in safety, though she may sheer about a great deal.

The wind continuing to increase when the ship is at B, she will forge still more ahead, and bring her anchor on her weather quarter. The yards must now be pointed to hold less wind, C', a most dangerous position for a vessel to be placed in, as she must presently break her shear. A light vessel would have swung head to wind long before this; and although she would sheer about with the tide under her counter, still she could not get near her anchor so long as the wind continues in the same direction.



By breaking her sheer she fills her yards, and staysail if up, and with the helm a-port as it was properly put, shoulders her anchor and shoots across the tide with it, perhaps ashore if there be shoal water in the vicinity, C". If there be no shoal to bring her up as at C", she will reach to windward as at C, taking her anchor with her to the imminent risk, not only of herself; but of other vessels near.

The object now is to get her head to tide again, and the wind on the other side; it is evident she will not ride to leeward, she must therefore be put to windward of her anchor, a manoeuvre only practicable during the strength of the tide. At any other time she would remain wind rode.

Riding to Windward. Instead of riding as at A, however, it would be better to sheer her with the starboard helm, and lie to windward of the anchor as at D. If now the wind increases, we must set the staysail and shoot her into the position E, where she will remain quiet: without the staysail as long as the wind is stronger than the tide; if the wind lulls, the staysail must be set again. If she lies uneasily, the after yards may be braced *up* and the head yards *abox*, when she will, in fact, be hove to with the tide on the starboard bow, the wind on the port beam, and the anchor on the starboard quarter, the strain on her cable being eased by the counteracting influence of wind and tide.

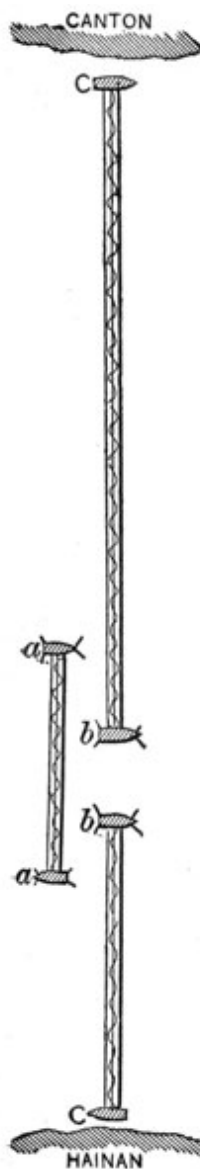
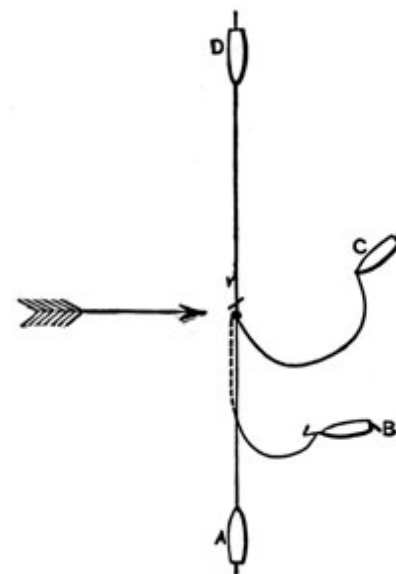
If the ship was not deeply loaded, of course she would swing head to wind

as the wind freshened. In these cases we suppose a strong tide and a heavy ship.

The ship being in the position E, when the tide slacks fill the head yards and put the helm hard a-starboard; as she swings into the position F, right the helm, haul down the staysail and point the yards to the wind; she will then drop into the position G.

With chain cables, it would be impossible to keep them taut from the anchor, except with a very short scope.

To Tend with the Wind Athwart the Tide. Let us suppose the ship A to be riding to the ebb, heading north, the wind at west. As the tide slacks put the helm hard a-starboard, and she will gradually come head to wind, as at B, when the staysail must be hoisted and the sheet hauled to windward. This will tend to force her astern and clear of her anchor. Her stern will then cant at C, when the helm may be righted and the head-sails hauled down. She will finally drop into the position D.



If there is no wind, and she drifts over her anchor, then is the time to *sight it*, that is, to heave it up and see that it is clear.

The foregoing cases will sufficiently illustrate the theory of tending ship. Every officer should be familiar with it, for although we rarely take much trouble to keep the anchor clear, still the helm should always be used when necessary.

If tending ship be entirely neglected, the anchor should be sighted occasionally, and, if necessary, the second one let go while the first is clearing.

Precautions against Fire-Rafts. The following were adopted by the English fleet in the Canton river, 1856-7:

Ships off the factories, moored head and stern, were protected by a boom thrown across the river, above and below the position. The largest boom, above the factories, was formed of two layers of large spars, lashed together, with a stream chain laid between them, bolted to the spars on alternate sides, and the whole woolded round at intervals.

The spars were not placed so as to lock in throughout, but a small space was left every forty feet or so, to impart flexibility to the boom. At *c c* were two loaded sunken junks. At *b b* two junks moored head and stern, with long thirty-two's mounted forward, and guns' crews on board. At *a a*, two junks, to which was attached a small boom to screen the entrance.

The ships were fortified With a spar from each bow, meeting, and lashed together at the outer ends, and dropped by a tackle from the jib-boom end. Flying jib-boom kept

40

in. From these outriggers, spars were continued aft to the gangways, supported by tackles from the lower yard-arms and boomed out by spars from the ship's side, which afforded space and shelter for the boats to be within.

From the jib-boom end was suspended a fire grapnel, or a small anchor, shackled by a length of small chain to the riding-cable, outside the hawse. This was intended to drop into the fire-vessel, and anchor her by, on the cable being slipped and the ship dropping clear.

Over the stern, an anchor was hung, which, in the event of a fire-vessel becoming fixed to the bows, would, on being let go, and the forward cable slipped, bring the ship by the stern, and throw the junk off.

As wooden tanks, containing upwards of a ton of powder floating at the water's edge, were occasionally sent down, the fire-booms were kept eased down, and floated on the water, and a guard-boat anchored ahead.

Destruction of Booms. Blow the boom up with powder; rouse up the bight of the chain; load with round shot a launch's gun; lash the chain across the muzzle; fire, and take advantage of the result. You may even fracture a chain in the same manner with a blank cartridge.

APPENDIX L.

TURNING EXPERIMENTS WITH THE S. S. HANKOW,

FROM THE REPORT OF THE BRITISH ASSOCIATION COMMITTEE FOR INQUIRY INTO THE STEERING OF STEAMSHIPS, 1877.

THE Hankow is a single-screw steamship, of 3,594.12 gross tonnage; net, 2,331.75 tons. Length, 389 feet; breadth, 42 feet 1 inch; depth, 28 feet 8 inches.

Her propeller is four-bladed, right-handed, with a diameter of 20 feet, and a pitch from 24 to 26 feet. The mean angle of its surface with a vertical athwart-ship plane would be 21°, hence the streams would be delivered on an average at an angle of 21° from the vertical fore-and-aft plane.

Experiments were conducted on March 8, 1877, in lat. 8° 50' S., long. 153° 58' E., between 9:20 and 11:30 A.M., as follows:

Sea smooth, or between 1 and 2 of Beaufort scale; ship drawing probably 24 feet 8 inches forward and 23 feet 8 inches aft.

First Experiment. Ship going ahead full speed (say 10 knots), engines were suddenly reversed, helm put hard aport; immediately the engines started, time noted, and bearing of ship's head by standard Admiralty compass noted, and the bearing of the ship's head also noted at every 15 seconds, until the ship came to a dead stop.

Time			Interval		Ship's head by compass	Head turned to-	
h	min	secs	m	secs		Port	Starboard.
9	20	7	-	-	N. 62 W	-	-
9	20	22	0	15	N. 62 1/2 W	0 1/2	-
9	20	37	0	15	N. 66 W	3 1/2	-
9	20	52	0	15	N. 69 W	3	-
9	21	7	0	15	N. 73 1/2 W	4 1/2	-
9	21	22	0	15	N. 77 W	3 1/2	-
9	21	37	0	15	N. 80 W	3	-
9	21	52	0	15	N. 84 1/2 W	4 1/2	-

9	22	7	0	15	N. 88 W	3 1/2	-
9	22	22	0	15	N. 88 W	Stationary	-
9	22	37	0	15	N. 87 W	-	1
9	22	52	0	15	N. 85 1/2 W	-	1 1/2
9	23	7	0	15	N. 84 W	-	1 1/2
9	23	22	0	15	N. 82 1/2 W	-	1 1/2
9	23	37	0	15	N. 79 1/2 W	-	3
0	3	30	3	30	-	26	8 1/2

Ship came to a dead stop in 3 min. 30 secs., and turned to port 26° in 2 min., and then to starboard 8 1/2° for 1 1/2 min.

Second Experiment. Ship going ahead full speed, say 10 knots. Engines suddenly reversed to full speed astern; helm put hard a-starboard, bearing on ship's head taken, and time as before.

628

Time			Interval		Ship's head by compass	Head turned to-	
h	min	secs	m	secs		Port	Starboard.
9	45	30	-	-	N. 39 W	-	-
9	45	45	0	15	N. 41 W	2	-
9	46	0	0	15	N. 41 W	Stationary	-
9	46	15	0	15	N. 39 1/2 W	-	1 1/2
9	46	30	0	15	N. 37 1/2 W	-	2
9	46	45	0	15	N. 32 1/2 W	-	5
9	47	0	0	15	N. 28 W	-	4 1/2
9	47	15	0	15	N. 24 1/2 W	-	3 1/2
9	47	30	0	15	N. 21 1/2 W	-	3
9	47	45	0	15	N. 28 W	-	3 1/2
9	48	0	0	15	N. 13 W	-	15
9	48	15	0	15	N. 9 W	-	4
9	48	30	0	15	N. 5 W	-	4
9	48	45	0	15	N. 2 1/2 W	-	2 1/2
9	48	53	0	8	N. 2 W	-	0 1/2
0	3	23	3	23	-	2	49

Ship came to a dead stop in 3 min. 23 secs. Her head paid off to port 2° during the first 15 secs., and afterwards turned to starboard 49° before coming to rest.

Third Experiment. Ship going full speed ahead, say 10 knots, the

Time			Interval		Ship's head by compass	Head turned to-	
h	min	secs	m	secs		Port	Starboard.
10	34	16	-	-	N. 29 1/2 E	-	-
			0	15	N. 29 E	0 1/2	-
			0	15	N. 29 1/2 E	-	0 1/2
			0	15	N. 30 1/2 E	-	1

			0	15	N. 32 E	-	1 1/2
			0	15	N. 36 E	-	4
			0	15	N. 39 E	-	3
			0	15	N. 44 E	-	5
			0	15	N. 46 1/2 E	-	2 1/2
			0	15	N. 48 E	-	1 1/2
			0	15	N. 50 1/2 E	-	2 1/2
			0	15	N. 51 1/2 E	-	1
			0	15	N. 52 E	-	0 1/2
			0	15	N. 53 1/2 E	-	1 1/2
			0	15	N. 54 E	-	0 1/2
			0	15	N. 54 1/2 E	-	0 1/2
			0	15	N. 55 E	-	0 1/2
10	38	31	0	15	N. 56 E	-	1
0	4	15	4	15	-	0 1/2	27

629

engines suddenly reversed to full speed astern, the helm put amidships, the bearing of ship's head noted by azimuth compass as before. Sea, wind, and weather as before.

Ship came to absolute rest in 4 min. 15 secs.; her head turned to port 0 1/2°, and then 27° to starboard, before coming to rest.

Fourth Experiment. In this case ship was going full speed astern, say about 9 knots, when the engines were suddenly reversed to full speed ahead; helm put hard to port; time and azimuth of ship's head noted as before. Sea, wind, and weather as before.

Time			Interval		Ship's head by compass	Head turned to-	
h	min	secs	m	secs		Port	Starboard.
11	3	11	-	-	S. 65 1/2 E.	-	-
			0	15	S 66 E	0 1/2	-
			0	15	S 67 E	1	-
			0	15	S 67 1/2 E	0 1/2	-
			0	15	S. 67 1/2 E	Stationary	-
			0	15	S. 66 1/2 E	-	1
			0	15	S. 65 1/2 E	-	1
			0	15	S. 63 1/2 E	-	2
			0	15	S. 60 1/2 E	-	3
			0	15	S. 57 1/2 E	-	3
			0	15	S. 53 1/2 E	-	4
11	5	56	0	15	S. 48 E	-	5 1/2
0	2	45	2	45	-	2	19 1/2

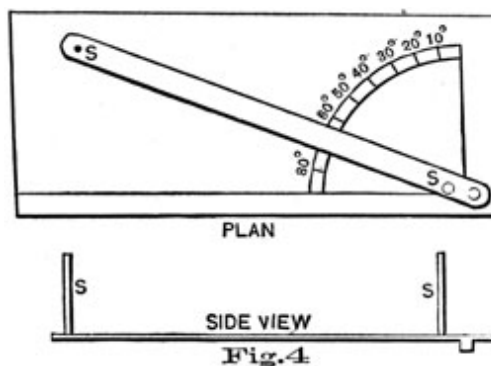
Ship came to dead stop in 2 min. 45 secs., and her head turned 2° to port in the first 45 secs., and 19 1/2° to starboard in the next 2 min.

To determine Tactical Diameter and Drift Angle. (*Lieut. Courmes' method.*)* At any convenient point forward two vertical battens are fixed in a plane perpendicular to the keel, and an observer is stationed

there. A second observer is stationed aft at a known distance from the first. This distance constitutes the base line for the experiment. To measure the angles to be observed, a measuring instrument may be used of the form devised by Mr. Martin, and illustrated in Fig. 4.

The zero line of this measuring instrument is made to coincide with, or be parallel to, the middle line of the ship.

When the helm is put over (Fig. 5) a buoy, B_1 is dropped overboard abreast the fixed battens and on the side toward which the ship is turning. When the ship in turning brings the buoy B_1 in line with the fixed batten, the observer at the after end of the base line measures the angle a between the first buoy and the base line,



* Revue Maritime, 1876.

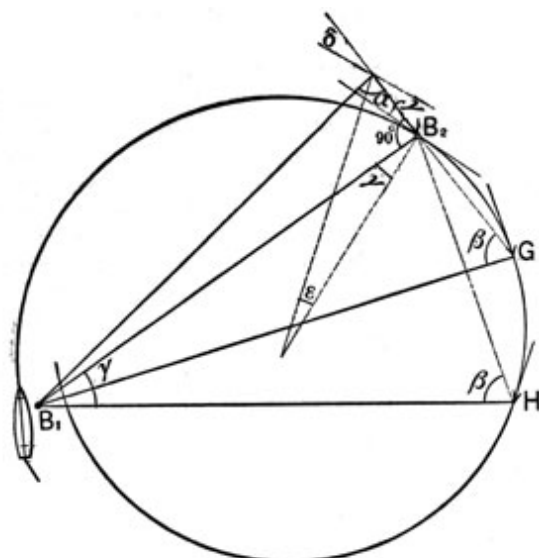


Fig. 5

For the forward end of the base line = $\gamma = 90^\circ - \beta$.

For the after end of the base line = $\delta = \gamma - \epsilon$.

and simultaneously a second buoy, B_2 , is dropped overboard abreast the cross battens. The ship is then allowed to move on a short distance to G, or a greater distance to H (according as we wish to determine the diameter of the first half circle or of the circle when motion has become more nearly uniform), and the observer forward then notes the angle β , which the two buoys subtend.

If l then represents the length of the base line-

Diameter = $l \tan \alpha \operatorname{cosec} \beta$, the curve traversed being regarded as arc of a circle.

The drift angle will be-

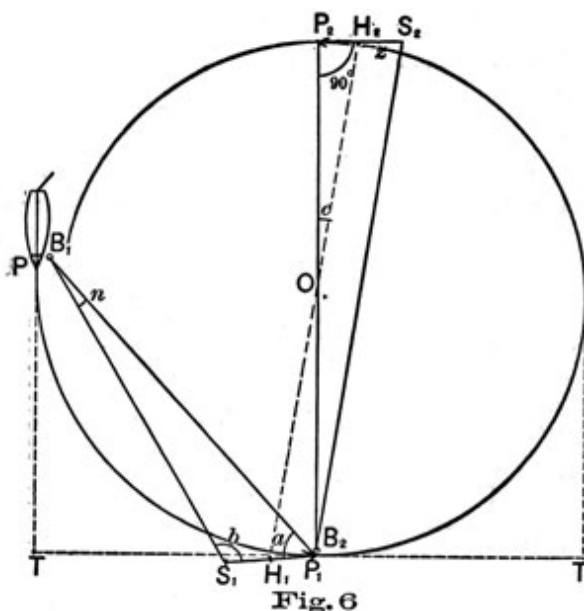


Fig. 6

*Lieut. Wyckoff's method.** Erect the usual cross-battens forward, and station one observer at these battens, which constitute the forward end of the base line. A second observer is stationed at the after end of the line. At the instant of putting the helm over, drop the first buoy, B_1 , abreast the cross-battens, noting the time. When the ship's head has turned through 90° , drop a second buoy, B_2 , also abreast the cross-battens, and simultaneously measure the angles a and b , subtended by the first buoy and opposite ends of the base line, Fig. 6. Note the time. When the second buoy comes abreast by the cross-battens, measure aft the angle z , subtended by the second buoy and forward end of base line. Note time when circle is completed. Let l represent the length of the base line, $P_1 S_1$.

$$P P_1 = (l \sin b) / \sin n$$

$$P_1 P_2 = l \tan z$$

$$T P_1 = P P_1 \cos a$$

$$T T_1 = (P_1 P_2)/2 + T P_1$$

And H_2 being the position of the centre of gravity of the ship, the drift angle c is determined from

$$c = P_2 H_2 / R, R \text{ being } P_1 P_2 / 2.$$

By this method the chord $P P_1$ and final diameter are determined when the first buoy has been ally one-third as long in the water as in the method described

* Lieut. A. B. Wyckoff, U. S. N.

in Navy Scientific Papers No. 7, pp. 34 and 35. There is less liability of error from the difference of effect of wind and tide on the vessel and buoys. It also does away with the assumption that $P_2 P_1 T$ is a right angle, which would usually be an error in practice.

Captain Mensing's Method.* At a moderate distance from the place of turning is anchored the largest available boat, or another vessel, having on board a good compass. Observers in the boat note at frequent but fixed intervals of time the bearing of the ship while turning, and simultaneously the masthead angle. From the turning ship observations are made of a suitable distant object, to determine the times at which the ship changes its azimuth by every 45° , or four points. These observations are taken from a point as near as possible to the mast whose bearing and masthead angles are being observed from the boat.

To determine the curve described by the ship a sheet of drawing paper is prepared-or a sheet of profile paper selected-with equidistant horizontal and vertical lines, the interval between the lines corresponding to the intended scale. Indicate on this sheet first the position of the boat in such a way that the vertical lines of the paper are made to correspond with the direction of magnetic meridians.

Plot on the paper from the position of the boat as a fixed point the different lines of bearing of the ship, corrected for deviation, and on each line lay off the ship's distance for the corresponding masthead angle. Indicate on the same sheet the magnetic course of the ship at starting, and by dropping a perpendicular to the line of direction of that course and halving the resulting right angles, lines of courses will be shown corresponding to each change of azimuth of 45° .

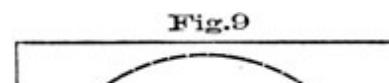
By comparing the times of the bearings taken in the boat with the times noted on board ship as the vessel changed her azimuth for every 45° , the points of the curve are determined where the ship changed her course for each 45° .

Drawing through these points parallels to the above lines of courses laid out at the starting point, we obtain the direction of the ship's head at those points, and by drawing through the same points tangents to the curve the drift angle for any position may be read off by means of a horn protractor. All other data, diameter, &c., can be read off similarly from the profile paper.

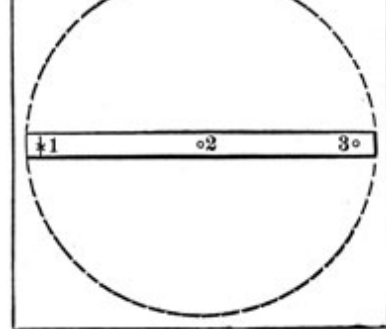
Accurately observed and plotted, this graphic method affords probably the best means of ascertaining the ship's track (especially during the first 90° of her change of direction), when shore stations are not available for observations.

In still waters, where several shore stations can be conveniently established-conditions readily obtained in the waters of the United States-either of the following methods will furnish very accurate results.

Lieut. Little's Method.** As practiced by the U.S.S. Minnesota in Newburgh Bay, 1881. Three stations as at A, B, C, Fig. 7, were



established at suitable points on shore, forming with each other nearly an equilateral triangle. An observer was stationed at each of these points with a plane table as shown in Fig. 9, with the addition of a straight edge fitted with front and rear sights like those upon a rifle, and having upon its lower edge a sharp pointed pivot 2, Fig. 8. Thus fitted, the straight edge could be removed from the table at pleasure, and when in position was allowed a free movement around the pivot.



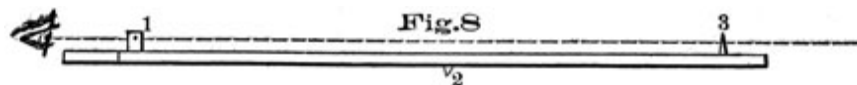
On board ship a flag was used at the main

to signal the moments of observation, and one observer was stationed at the

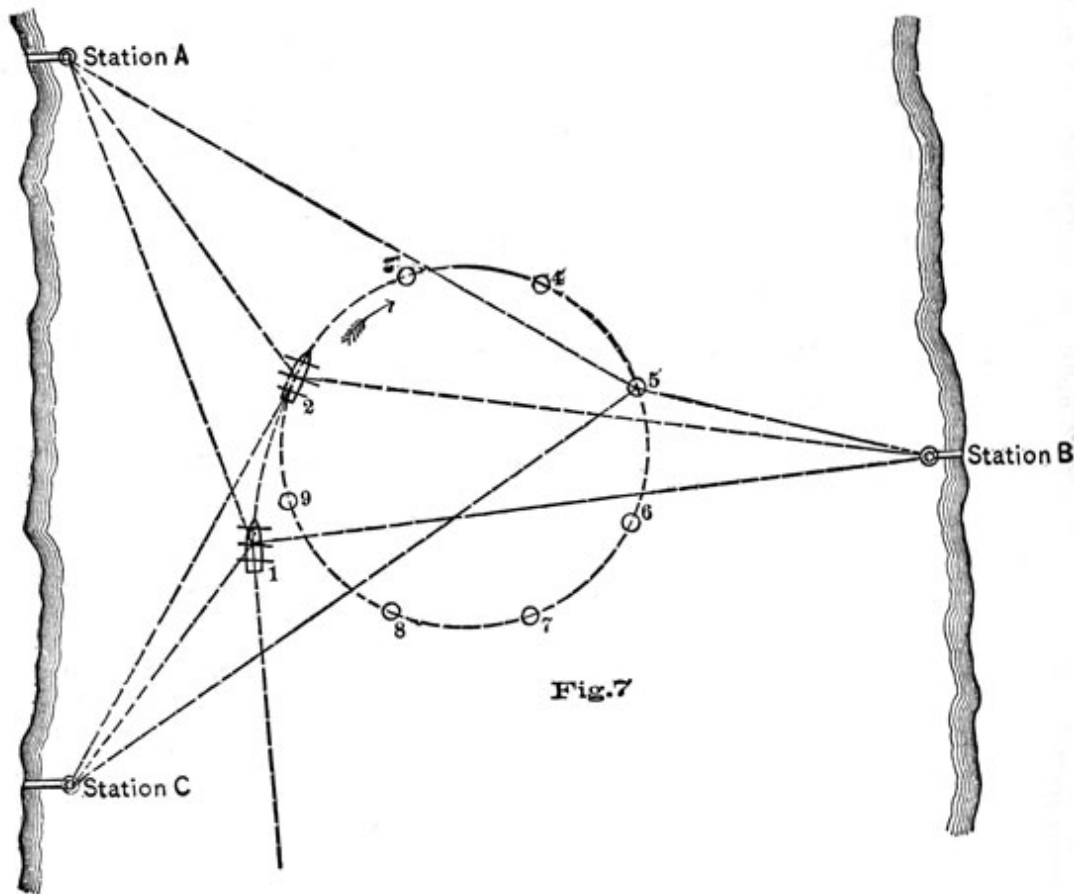
* A full description of this method will be found in Marine-Verordnungsblatt No. 16, of 1876.

** Lieut. W. McC. Little, U. S. N.

compass, near the mainmast. When the ship approached the position (Fig. 7) for the commencement of the trial the flag was run up to the truck as a signal to "stand by." Each observer then followed with his eye the mainmast of the ship



in a line through the sights on the straight edge of the plane table. The flag was then dipped as a signal to "mark," and the helm put hard a-port. The line of each straight edge was marked at the instant of signal.



In like manner the bearing was noted at each station when the helm had been put hard over, and thereafter at each succeeding change of two points in the direction of the ship's head, until the circle had been completed.

At the conclusion of the trial the various points 1, 2, 3, 49 were established by means of the intersections of the lines of bearing from the various stations, and a curve drawn through them gave the actual track of the vessel while turning.

Siegel's Method* may be noticed as available with shore stations, or when the shore presents a suitable feature to "line" upon at F_1 , when F may be a boat or other vessel.

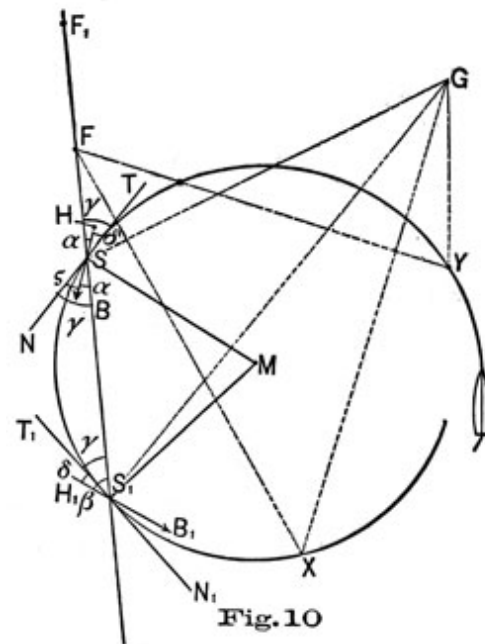
If two objects, $F F_1$, not too distant from each other, are so situated that the

* Lieut. Siegel, Imperial German Navy.

vessel in turning can bring them in line while passing within a short distance of the nearest one. we may obtain as follows:

A. *The Drift Angle.* In describing the circle with the ship, arrange the course so that the two objects $F F_1$, Fig. 10, will be in line when the ship has turned through at least eight points. Measure the angle, α , between the fore and aft line of the ship and the line of bearing $S F$ of the two objects. When, in continuing the circle, the ship again brings F and F_1 in line, measure similarly the angle β .

The line $S S_1$ is a chord of the curve, considered as a circle, and were there no drift angle the line of the ship's keel at $H B$ and at $H_1 B_1$ would coincide respectively with the tangents $T N$ and $T_1 N$, to the curve, and the angle between the line of bearing of the two objects and the tangents, or γ , would be the same as the angles α and β . But as it is, $\alpha = \gamma - \delta$ and $\beta = \gamma + \delta$ therefore $\delta = (\beta - \alpha)/2$, the drift angle.



B. *To Determine the Diameter of the Circle.* If at the time of crossing the line of bearing of $F F_1$ we can measure from the point F the masthead angles of the ship and so determine the distances $F S$ and $F S_1$, the diameter will be found from: $\text{diam.} = (S S_1) / (\sin. ((\alpha + \beta)/2))$

Another available station at G would give bearings to verify the positions of the ship by cross-bearings with the range line $F F_1$, and to determine any points of the circle, as at X and Y , by the three point problem.

Other Methods. It has also been proposed to measure the tactical diameter and drift angle by turning around a single anchored ship or buoy, using the usual base line on board. Of these methods it may be noted that unless the central part of the curve lies near the fixed point, there occur positions of the turning ship in which the observed angles are so near 0° or 180° as to render the computation or construction of the triangles uncertain.

All methods in which two or more buoys are dropped overboard share the objection due to difference in drift of ship and buoys. There is also a practical inconvenience, unless a large number of buoys are available, since it becomes necessary to stop to pick up the buoys, when as a rule it is desired to measure the diameters of a number of circles in quick succession.

Estimating the diameter of the circle by counting the revolutions of the engine and thence deducing the speed is liable to lead into serious error. Owing to the drift angle the speed corresponding to a given number of revolutions is much less when the ship is turning than when she is on a straight course. In the Thunderer a speed of 10.4 knots was obtained with 65 revolutions on a straight course, whereas on the circle 59 revolutions only gave a speed of 7.14 knots.

Towing a patent log astern while the ship turns through 360°, and regarding the registered distance as a circumference from which the diameter may be calculated, is also said to be less trustworthy than any good geometrical method. The reason probably lies in the changes of speed known to occur in turning, and in the effect of the wake. A speed indicator (see Chapter III.) read at frequent

intervals, would probably give a more accurate result, and would at any rate be useful in combination with the other methods described.

Handling Single Screw Vessels under Steam. *German Naval Experiments.* In Pamphlet No. 37 of the Professional Series issued by the German Admiralty, the results of experiments made with eighteen different vessels of the German Imperial Navy are given in detail.

The pamphlet was received after this book was already in print. Only the conclusions reached can be given here, for comparison with the suggestions made in this work, pp. 538 to 547.

The Friedrich der Grosse experiments are summed up in this more recent pamphlet, and the detailed description of them is therefore omitted here.

The vessels whose experiments are quoted comprise ironclads, corvettes of old and modern types, gunboats, and steam launches. A partial description of them is given in the table on the following page.

Although some of the trials were not made by all of the vessels named, the results obtained were deemed of sufficient importance to suggest the following rules:

I. Ship and Screw Moving Ahead. In starting from rest neither right nor left-handed screw vessels show decided and invariable deflection of the bow; in the majority of instances the influence of the lower screw blade is paramount e. the bow of vessels with right-handed screws tends to turn to port).

When moving ahead at speed the bow of left-handed screw vessels falls off to port, and of right-handed screw vessels to starboard.*

With the helm hard over and starting from rest, ships with left-handed screws turn quickest with a port helm, those with right-handed screws answer the star board helm quickest.

If the helm is put hard over when moving ahead at speed, left-handed screw ships turn quickest with a starboard helm, and right-handed screw ships with a port helm; the quickest turn in a motion being obtained when the rudder is turned toward the descending blade of the screw. **

The rudder has steering power as soon as the vessel begins to move ahead from a standstill, and promptly overcomes the turning tendency of the screw.

The wind has its least effect upon the ship when starting; when moving ahead at speed the ship tends to come to, with a beam wind; the tendency overcoming the screw-turning effect and often requiring considerable weather-helm to counteract it, if the breeze is fresh.

II. Ship and Screw Backing. In backing from a standstill the bow of vessels with left-handed screws turns to port, and if the screw is right-handed, to starboard.

When moving astern in a calm and smooth water this deflection of the bow generally continues in the same direction.

The wind has minor effect on a vessel starting astern. When moving astern its influence (if the breeze is

strong engine) will become the controlling one; the ship will turn stern to wind against both screw and rudder.

The rudder has little effect when starting to back from rest. It will only affect the ship when some sternway has been gathered, and even then to a much less degree than if the ship were moving ahead at an equal speed. Often it only suffices to keep the ship on a straight course astern. Ships with a left-handed screw will answer the port helm quickest, those with a right-handed screw the starboard helm.

III. Ship Moving Ahead, Screw Backing. With midship helm, in vessels with left-handed screws, the bow turns to port; with right-handed screws the bow turns to starboard.

* Which agrees with the results predicted by Mr. Maginnis, see foot-note, p. 445. The probable reason why available American data do not bear out this conclusion is that the requisite speed is not developed.

** The gunboats Hynne, Nautilus, and Habicht, three of the smallest and slowest vessels tried, gave results contrary to the above rule—turning quickest with the port helm—screws left-handed. The Cyclop, another small vessel, followed the rule.

List of Vessels with which were made the Experiments Described in German Admiralty Pamphlet No. 37.

NAME	CLASS OF SHIP	Hull					Indicated H.P.	Maximum Speed	Screw		Remarks.
		Length on water line	Beam	Displacement Tons	Draft, forward	Draft, aft			Number of blades	Right or Left handed.	
PREUSSEN	Armor-belted turret ship	308' 6"	53' 6"	6748	23'	24' 8"	5327	14	Four	Left	
FRIEDRICH DER GROSSE	"	298'	52'	6558	23'	24' 8"	5327	14	Four	Left	
FRIEDRICH KARL	Armor-belted, broadside ship; ram; bark-rigged	290'	54' 6"	5819	22'	24'	3450	13.5	Four	Right	
KRONPRINZ	"	286'		5393	22' 8"	24' 6"	4735	14.3	Two	Left.	
BISMARCK	Iron; Gundeck Corvette	244' 5"	45' 1"	3863	Mean 21' 8"		2817	15	Two	Left	New type, fast cruiser.
FREYA	Wood; Gundeck Corvette			1954				14	Four.	Left.	"
ARIADNE	"			1665				13	Two	Left	"
VINETA	"			2227				11	Two	Left	Old type, cruiser.
NYMPHE	Second Class Corvette			1760				12	Two	Left	"
VICTORIA	"			1760				12	Two	Right	"
MARS	Gunnery Ship			1650				12	Four	Left	"
NAUTILUS	Gunboat			695				10	Two	Left	
CYCLOP	"	138' 4"	22' 11"	400				10	Three	Right	Hirsh propeller.

HYANE	"	139' 2"	25' 1'	480			8.5	Two	Left	
HABICHT	"			260			8	Two	Left	
GRILLE	Dispatch Vessel			337				Three	Left	
LAUNCH "ARIADNE"	Steam Launch							Four	Right	
LAUNCH "VINETA"	"							Four	Right	

636

With the helm hard over, vessels with left-handed screws answer quickest to the port helm; vessels with right-handed screws to the starboard helm; as for sternboard.

The helm must not be put over too soon, especially if the vessel is still going ahead at high speed, otherwise it may act as for headway.

The helm is best laid *after* the screw commences to back, when it will act as, if the ship had sternway.

Vessels with steam steerers can insure the intended manoeuvre by a short period of helm laid for headway *before* the screw begins to back, when the helm must be shifted (i.e., a vessel with a right-handed screw and steam steerer going ahead at full speed, wishing to stop and turn ship's head to starboard, will first port the helm and shift it to hard a-starboard by the time the screw begins to back).

In this manoeuvre the wind, if moderate, has no great effect.

IV. Ship going Astern, Screw working Ahead. If the helm is amidships, ships with left-handed screws turn first to starboard, those with right-handed screws to port, but the bow subsequently may deviate in the same direction as if the ship were moving ahead.

The helm can be put over as soon as the screw is reversed and working ahead, and it will affect the ship as if she were starting ahead.

If a vessel has a left-handed screw, she will answer her port helm quickest, and if a right-handed screw her starboard helm quickest.

The wind has no special influence on the ship in this manoeuvre; in fact, as far as noted, the chief effect of a breeze is on vessels in motion, either with headway or sternway; a beam wind in this case making them come to when going ahead and fall off if going astern. When just starting in either direction the influence of a moderate breeze is small.

637

SPEED AND STEERING TRIALS S.S. "STRATHEDEN,"

OWNERS, J. HAY AND SON, GLASGOW.

Fitted with Kunstaedter's Steering Screw.

Dimensions of Ship. Length over all, 284 feet. Beam, 38 feet. Depth of hold, 16 feet.

Engines. Compound direct acting. Cylinders, 34" and 66". Stroke, 39". Horse Power. 200 nominal; 1,100 to 1,200 indicated.

Main Propeller. Cast-iron. Diameter, 14 feet 6 inches. Mean pitch, 17 feet 5 inches.

Steering Screw. Steel blades. Diameter, 10 feet. Pitch variable. Weight of propeller, all fittings, extra

joint, etc., about 3 tons.

Rudder Surface. 54.5 square feet.

SPEED TRIALS.

	DRAFT		STEAM	VACUUM	REVS	TIME	SPEED	REMARKS.
	For'd	Aft						
First Trial. Mean of 3 runs	5' 6"	10' 9"	75 lbs	26 1/2"	85.5	5 25	11.054	Steering screw working
Second Trial. Mean of 6 runs	5' 6"	10' 9"	69 lbs	27"	82	6 14	9.703	Steering screw removed.
Third Trial. Mean of 5 runs	6' 7"	12'	79 lbs	27"	77.2	5 27	11.009	Steering screw working.
Fourth Trial. Mean of 2 runs	15' 3"	15' 9"	74 lbs	26 1/2"	67	5 15	11.428	Steering screw working. Ship loaded.

STEERING TRIALS.

(WORKED BY STEAM STEERING GEAR.)

No. 1. WITH BLADES OF STEERING SCREW REMOVED, AND STEERING WITH COMMON RUDDER. Draft forward, 5 ft. 6 in.; Aft, 10 ft. 9 in.

	1st EXPERIMENT. Starboard. Time	2nd EXPERIMENT. Port. Time	3rd EXPERIMENT. Starboard. Time.
From start to helm hard over	8 1/2 secs	10 secs	7 secs.
90° from start	2 min. 55 secs	1 min. 45 secs	3 min. 30 secs.
180° do	4 min. 45 secs	2 min. 55 secs	5 min. 20 sees.
270° do	7 min. 0 secs	5 min. 15 sees	7 min. 10 secs.
360° do	8 min. 5 secs	7 min. 20 secs	8 min. 40 secs.

NOTE.-During 1st and 3rd experiments, revolutions of engines were 75 per minute, but during 2nd, were 77 per minute.

No. 2. WITH STEERING SCREW WORKING. Draft forward, 6 ft. 7 in.; Aft, 12 ft.

	Steam	Vac	Revs	Time. M.S.	Degrees	REMARKS.
No. 1,	68	27"	70	4.55	Complete Circle	Vessel going full speed ahead; helm hard a-starboard.
No. 2,	55	26 1/2"	61	3.9	180	Full speed ahead, helm a-port.
				5.58	Complete Circle	
No. 3,	55	26 1/2"	61	1.44	90	Continuation of No. 2.
				2.53	180	
				4.23	270	
				6.21	Complete Circle	
No. 4	68 to 61	27"	70	3.0	180	Full speed; starboard helm.
				6.7	Complete Circle	

No. 5,	61	27"	70	6.17	Complete Circle	Continuation of No. 4.
No. 6,	60	27"	68	7.27	Complete Circle	Vessel dead still. Engines started full speed a astern. Vessel turned round in about 2 1/2 lengths.

No. 3. WITH STEERING SCREW WORKING. Vessel loaded to her deep load draught, viz., 15 ft. 3 in. forward, and 15 ft. 9 in. aft; mean, 15 ft. 6 in.

	Steam	Vac	Revs	Time. M.S.	Degrees	REMARKS.
No. 1,	74	27 1/2"	67	0.36	45	Vessel going ahead, helm hard a-starboard. Half Circle complete in 2 min. 14 sec.
				0.75	90	
				2.14	180	
No. 2,	68	27"	56	2.23	180	Vessel going ahead, helm hard a-starboard.
				5.3	Complete Circle.	
No. 3,	68	27"	56	2.43	180	Vessel going ahead, helm hard a-port.
				6.2	Complete Circle	
No. 4,	68	27"	56	4.16	180	Vessel going astern, helm hard a-port.
No. 5,	68	27"	56	4.2	180	Vessel going astern, helm No. hard a-starboard.

With the vessel going full speed ahead on a straight course, the engines were suddenly reversed to full speed astern, and the helm put hard over, when it was found that the vessel was immediately drawn out of her course by the action of the rudder screw and the way was taken completely off the ship in less than twice her own length. With the steering screw in action, the vibration was scarcely perceptible.

NOTE.-The helm was also put over by screw hand gear in a ready and satisfactory manner.

REPORT OF TURNING TRIALS U.S.S. QUINNEBAUG, EUROPEAN STATION, COMMANDER

W. WHITEHEAD, COMMANDING.

LIEUT. COMMANDER BARBER,

Observers: ENSIGN J. T. SMITH,

CADETS WOODWARD, RIDER AND BUCK.

DATE	HELM					SPEED			TIME OF TURNING						Heel °	Revolutions of screw No.	Steam pressure. lbs.
	Direction	Position	Angle °	Time in putting over		Rate	On straight course	On curve.	90°		180°		360°				
				Min	Secs		Knots	Knots	Min	Secs	Min	Secs	Min	Secs			
	Starboard	Hard over				Full *											
	Port	Hard over				Full											
	Starboard	Half over				Full											
	Port	Half over				Full **											
Feb. 10, 1883	Starboard	Hard over	20	0	20	2/3	6.8	6.0	2	05	4	05	8	47	0	39	43

"	Port	Hard over	20	0	24	2/3	6.0	6.0	2	26	4	49	9	08	0	36	43
"	Starboard	Half over	10	0	10	2/3	6.8	6.6	3	06	6	16	11	36	0	37	43
"	Port	Half over	10	0	08	2/3	6.4	6.4	3	06	6	03	11	33	0	39	44
"	Starboard	Hard over	20	0	22	1/2	4.4	4.2	3	44	6	12	12	55	0	28	42
"	Port	Hard over	20	0	18	1/2	5.2	4.4	2	56	5	48	11	28	0	28	42
"	Starboard	Half over	10	0	08	1/2	5.0	4.0	5	20	9	53	18	36	0	28	42
"	Port	Half over	10	0	08	1/2	4.8	4.6	3	57	7	45	15	23	0	28	42

* Full speed impossible, owing to defective boilers; six were in use.

** The maximum helm angle obtainable is 20°.

640

REPORT OF TURNING TRIALS U.S.S. QUINNEBAUG (Continued).

TACTICAL DIAMETER		Diameter of curve	Advance	Transfer	Drift angle	Mean angular velocity per second	Condition of Sea	WIND		CURRENT		REMARKS.
Feet.	Method used.	Feet.	Feet.	Feet.	°			Direction	Force	Direction	Force.	
Method Lieut. Coumes	Method by log					°					Ship's head before turning.	The origin of all the circles was a ballasted barrel with a flag. This barrel had very little drift. The second object thrown overboard in each case was an empty box or barrel which had considerable drift. Great difficulty is experienced in this vessel in finding two points on her deck where bearings can be taken at all times, on account of the boats which obstruct the view. It is
1713	1700	1750	875	875	13	0.41	Smooth	W.N.W	2	No Current	W. by N.	
2035	1767	1767	884	884	23	0.39	"	"	2	"	N.E. by N.	

			°	Min	Secs		Knots	Knots	Min	Secs	Min	Secs	Min	Secs	°	No.	lbs.
Sept. 6, 1882	Starboard	Hard over*	20°	0	37	Full	10.8	9.6	1	55	3	20	6	39	1	62	63
"	Port	Hard over*	22	0	40	Full	10.5	9.6	1	44	3	02	5	45	1 1/4	60	65
"	Starboard	Half over	12	0	18	Full	10.8	10.5	2	30	5	00	9	20	1/2	61	61
"	Port	Half over	12	0	14	Full	10.5	10.4	1	35	3	30	8	13	1/2	60	65
"	Starboard	Hard over	32	0	50	2/3	8.0	6.2	1	55	3	27	6	33	1/4	42	65
"	Port	Hard over	31	0	51	2/3	8.0	6.4	1	45	3	10	6	26	1/4	42	63
"	Starboard	Half over	16	0	20	2/3	6.7	7.0	2	35	4	34	8	30	1/8	42	65
"	Port	Half over	16	0	16	2/3	8.0	7.4	2	20	3	08	7	35	1/4	42	60
"	Starboard	Hard over	34	0	45	1/2	5.6	5.0	2	30	4	35	8	34	0	30	68
"	Port	Hard over	34	1	30	1/2	5.2	4.0	2	38	5	23	9	43	0	29	70
"	Starboard	Half over	17	0	16	1/2	5.2	5.0	3	08	5	36	10	33	0	30	62
"	Port	Half over	17	0	28	1/2	5.2	5.0	2	35	5	25	9	50	0	30	62

642

REPORT OF TURNING TRIALS U.S.S. ENTERPRISE (Continued).

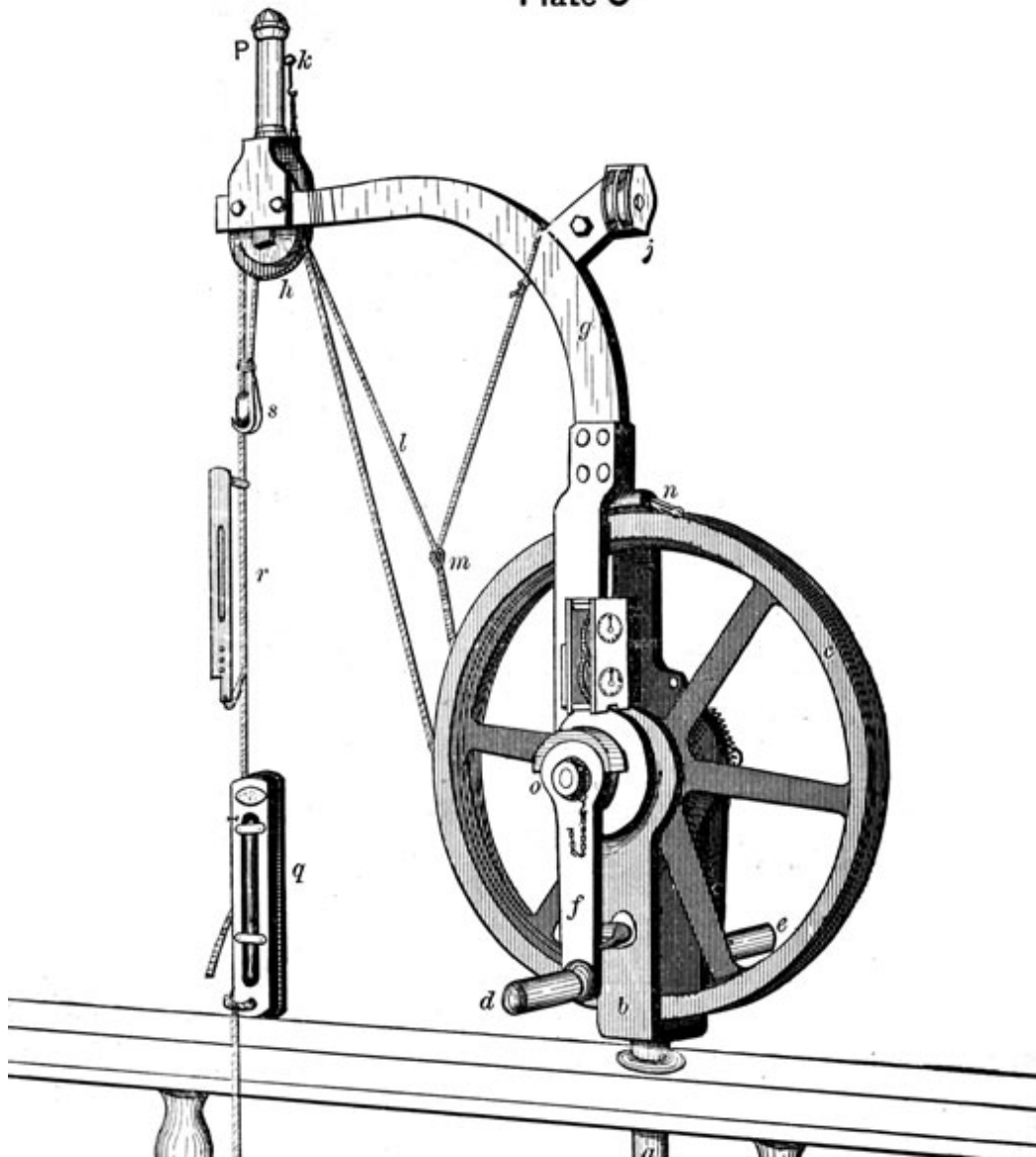
TACTICAL DIAMETER		Diameter of curve	Advance	Transfer	Drift angle	Mean angular velocity per second	Condition of Sea	WIND		CURRENT		REMARKS.
Feet.	Method used.	Feet.	Feet.	Feet.	°			Direction	Force	Direction	Force.	
1688		1713*	1176	831	4° 10'	54'	Very smooth	Calm		Not ascertained	Not ascertained.	* With four men at wheel and relieving tackles manned, impossible to get helm further over. ** Discrepancies probably due to errors (small) in data and set of current.
1557		1587	1089	780	4° 30'	61'	"	"		"	"	
1950		1875	980	865	3° 35'	38'	"	"		"	"	
1931		1899	871	982	3° 45'	44'	"	"		"	"	
1464		1309	889	810	5° 20'	55'	"	"		"	"	
1269		1188	942	675	5° 55'	57'	"	"		"	"	
1790		1899**	1368	840	3° 45'	42'	"	"		"	"	
1624		1782**	1158	733	4° 00'	47'	"	"		"	"	
1312		1278	1047	673	5° 30'	42'	"	N.by W.	2	"	"	

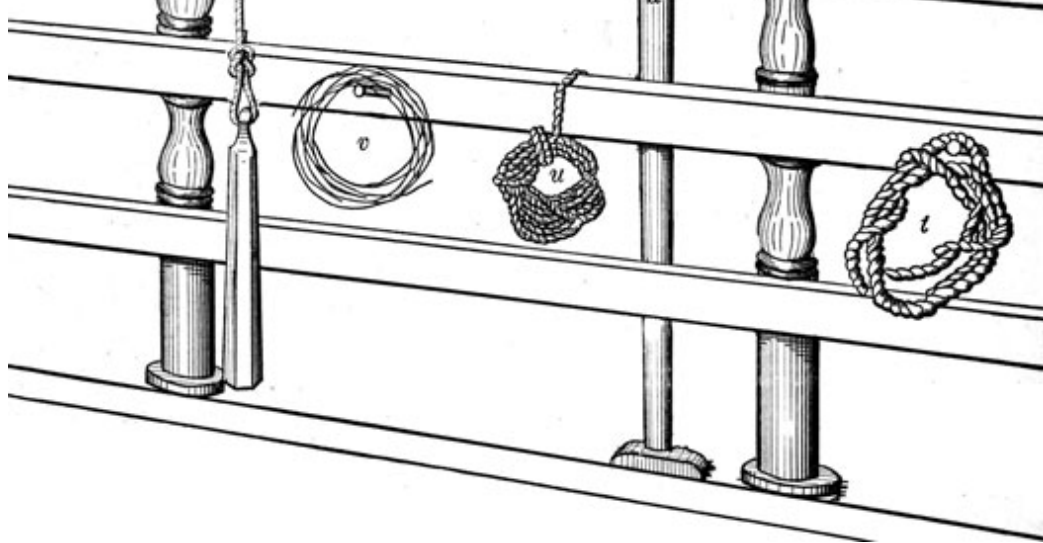
REPORT OF TURNING TRIALS U.S.S. TENNESSEE (Continued).

TACTICAL DIAMETER		Diameter of curve	Advance	Transfer	Drift angle	Mean angular velocity per second	Condition of Sea	WIND		CURRENT		REMARKS.
Feet.	Method used.	Feet.	Feet.	Feet.	°			Direction	Force	Direction	Force.	
2464	Martin's with additions by Capt. Long	2505	1434	1189	6° 20'	24'	S	N. by W	2-3	None	None.	
3192		3075	2247	1632	5° 10'	24'	"	"	2	"	"	
2879		2843	1389	1435	5° 35'	24'	"	"	1	"	"	
2870		2827	1363	1434	5° 37'	24'	"	"	0-1	"	"	

Length of Vessel on L. W L 353 feet Kind of rudder Balanced.
 Beam 45 feet Kind of screw 4-bladed, left-handed.
 Displacement 4,840 tons Pitch of screw 31.5 feet:
 Draft for'd, 18 feet 3 inches. Aft, 22 feet 4 inches Mean angle of blade with vertical athwartship plane 27° 50'

Plate C





APPENDIX M.

TANNER SOUNDING MACHINE.

The machine, Plate C, is mounted on the rail in readiness for sounding.

The spindle, *a*, which ships in the rail, is of wrought iron, screwed firmly into the base of the brass frame *b*, that carries the reel. The frame above mentioned is cast in one piece, is bored to receive the shaft, and has appropriate lugs for the paul, register, clamp *f*, spindle, and arm at *i*. The reel, *c c*, is of cast brass and will hold 2000 fathoms of sounding wire, one fathom to a turn on the first layer, increasing as the score is filled. The friction groove common to all sounding reels is on the right side.

The cranks, *d*, *e*, by which the reel is turned, have conical friction surfaces, which are brought into action by turning the right crank, *e*, half a turn ahead, crank *d* remaining clamped, or held firmly in the hand. The reverse motion releases the reel and it turns freely without moving the cranks.

On the left of the frame, between it and the crank is a worm wheel which operates the register. The ratchet and paul are on the right, between the frame and crank. The arm *g*, supporting the guide pulley *h*, is of flat bar iron, its lower end riveted to the frame between the lugs, The later machines have a hinge at this point composed of a single bolt and pin; the latter being withdrawn, the arm lowers, bringing the guide pulley inside of the frame, when the reel is unshipped.

The small metal block, *j*, projecting from the arm, is part of a tackle for suspending the reel when mounting and dismounting. The guide pulley, *h*, is of brass, with a deep groove for the wire; it works between guides which terminate in a spindle enclosed in a brass cylinder, *p*. The pulley is suspended by a coiled spring surrounding the spindle above mentioned, which allows it a vertical motion of about three inches. A brass guard surrounds the upper portion of the pulley to prevent the wire from flying off if suddenly slacked. A small arm, *k*, projects from the upper end of the spindle and works through a slot in the cylinder *p*. The standing part of the friction line is secured to the eye *n*, carried around the reel in the friction groove to *m*, where a small line, *l*, is made fast to it on the bight, one end being made fast to the arm *g*, and the other to the arm *k*, the slack of the line being taken in before the weight of the lead is taken on the sounding line. In this position considerable force will be required to move the reel; but the lead being suspended, the spring is compressed and the tension on the friction line relieved, allowing the reel to revolve freely.

A Negretti and Zambra deep-sea thermometer in the wooden case furnished by the makers is shown at *q*. The same thermometer in Tanner's metal case is shown at *r*; the metal messenger which is sent down on the wire to release the slip hooks and reverse the thermometer is suspended at *s*. The comparative sizes of the ordinary deep-sea lead line, the hand line, and sounding wire are shown at *t*, *u*, *v*.

The machine turns freely, the guide pulley taking the direction of the wire if, from any cause, it trends out of the perpendicular. A set screw is provided in the rail bearing for clamping the machine to steady it while heaving in.

The reel is usually kept in a tank of oil when not in use, to preserve the wire. By an ingenious arrangement, for which we are indebted to Mr. Tippet, draughtsman at the Ordnance Department, Navy

Yard, Washington, D. C., the reel is unshipped by simply unscrewing the nut *o*, shown on the face of crank, *d*, and withdrawing the shaft to the right, leaving the ratchet, worm wheel, and crank *d* in position.

The total weight of the machine is 128 lbs.

The wire used is purchased from the Washburn and Moen Manufacturing Company, Worcester, Mass., and is called by them "No. 11, Music "; it weighs

646

.0145 of a pound to the fathom, or 14.5 lbs. to the nautical mile, and has a tensile strength of 200 to 250 pounds.

The method of splicing is simple and effective. The ends of the wire for about 2 feet are thoroughly cleaned and laid together with about eight long-jawed turns; the ends and two or three intermediate points are wound with very fine wire and covered with solder, which is smoothed with a knife and sand paper.

The stray line to which the lead is bent consists of about three fathoms of cod line spliced to the sounding wire in the following manner. The end of the wire is stuck twice against the lay, about six inches from the end of the stray line, then passed with the lay for about six inches, the end stuck twice against the lay and served over with seaming twine. The wire is then worked in with the lay to the end of the line, the strands trimmed down and served over with twine; a seizing is also put over the wire first stuck against the lay. This makes a smooth and secure splice which passes readily over the guide pulley without danger of catching under the closely fitting guard.

To take a sounding, the machine being mounted as shown in the plate, with lead bent on, cranks out of action and friction line at the proper tension; with the left hand turn the reel slightly and reverse the paul, then with the right hand on the friction line at *m* governing the movements of the reel by slight pressure up or down, lower the lead care fully to the water's edge, set the register and proceed to take the sounding, taking care that the wire is not allowed to run out faster than the lead will sink. When the lead strikes the bottom, the friction line, assisted by a slight pressure of the hand, if necessary, will stop the reel. The number of turns will then be read on the register and corrected to give the fathoms.

If a temperature is to be taken with the apparatus shown at *r* and *s*, give the reel a turn or two by hand to get the lead off the bottom, wait the proper time for the thermometer to take the temperature and allow the messenger to run down the wire, detach the slip hooks and capsize the instrument, and register the temperature.

To heave the lead up, clamp the machine to keep it steady, bring the cranks into action by turning the right one half a turn ahead, unclamp the left one and heave away.

To use piano wire successfully for sounding, it must be borne in mind that a kink or even a short nip means a break; therefore great care is required in handling it.

APPENDIX N.

SHIPS' PAPERS.*

Every merchant vessel should carry on board some official voucher for her nationality, issued by the authorities of the country to which she belongs.

The official voucher of a vessel which belongs to a country possessing a register of its mercantile marine, is a certificate of her registry; in other cases its form varies and passes under different names-" Passport," "Sea-brief," &c.

The Certificate of Registry is a document signed by the registrar of the port to which the vessel belongs, and usually specifies the name of the vessel and of the port to which she belongs; her tonnage; the name of her master; particulars as to her origin; the names and description of her registered owners.

The Passport purports to be a requisition on the part of a sovereign power or state to suffer the vessel to

pass freely with her company, passengers,

* From "The Sailor's Pocket Book," by Capt. F. G. D. Bedford, R. N.

goods and merchandise, without any hindrance, seizure, or molestation, as being owned by citizens or subjects of such state. It usually contains the name and residence of the master; the name, description, and destination of the vessel.

The Sea-letter, or Sea-brief, is issued by the civil authorities of the port from which the vessel is fitted out; it is the document which entitles the Master to sail under the flag and pass of the nation to which she belongs; it also specifies the nature and quantity of the cargo, its ownership, and destination.

The Charter-party is the written contract by which a vessel is let, in whole or in part, the person hiring being called the charterer. It is executed by the owner or master, and by the charterer. It usually specifies the name of the master, the name and description of the vessel, the port where she was lying at the time of the charter, the name and residence of the charterer, the character of the cargo to be put on board, the port of loading, the port of delivery, and the freight which is to be paid. The Charter-party is almost invariably on board a vessel which has been chartered.

The Official Log-book is the log-book which the master is compelled to keep in the form prescribed by the municipal law of the country to which the vessel belongs.

The Ship's Log is the log kept by the master for the information of the owners of the vessel.

The Builder's Contract is to be expected on board a vessel which has not changed hands since she was built. It is not a necessary document, but it sometimes serves, in the absence of the Pass or Sea-letter or Certificate of Registry, to verify the nationality of the vessel.

The Bill of Sale is the instrument by which a vessel is transferred to a purchaser. It should be required whenever a sale of a vessel is alleged to have been made either during a war then in progress or just previous to its commencement, and there is any reason to suspect that the vessel is liable to detention, either as an enemy's vessel or as an American or allied vessel trading with the enemy.

Bills of Lading usually accompany each lot of goods.

A Bill of Lading on board of a vessel is a duplicate of the document given by the master to the shipper of goods on the occasion of the shipment, the name and destination of the vessel, the description, quantity, and destination of the goods, and the freights which are to be paid.

The Invoices should always accompany the cargo; they contain the particulars and prices of each parcel of goods, with the amount of the freight, duties, and other charges thereon, and specify the name and address of the shippers and consignees.

The Manifest is a list of the vessel's cargo, containing the mark and number of each separate package, the names of the shippers and consignees, a specification of the quantity of goods contained in each package, as rum, sugar, &c., and also an account of the freight corresponding with the Bills of Lading.

The Manifest is usually signed by the ship-broker who clears the vessel out at the custom house, and by the master.

The Clearance is the certificate of the custom house authorities of the last port from which the vessel came, to show that the custom duties have been paid. The Clearance specifies the cargo and its destination.

The Muster Roll contains the name, age, quality, place of residence, and place of birth of every person of the vessel's company.

Shipping Articles are the agreement for the hiring of seamen. They should be signed by every seaman on

board, and should describe accurately the voyage and the terms for which each seaman ships.

The Bill of Health is a certificate that the vessel comes from a place where no contagious disease prevails, and that none of her crew at the time of her departure were infected with such disease. It must be *vised* at the port of departure by the consul of the nationality of the port of arrival.

BUGLE CALLS.

FOR U. S. TRAINING SHIPS.

Arranged by Lieut. WM. McC. LITTLE, U.S. Navy.

RECOMMENDED FOR THE GENERAL SERVICE.

CALL. Quick.



REVEILLE. Quick.



1 2

1 2

1 2

1 2

1st. 2d. 3d.

MORNING COLORS. *Quick Time.*

1st. 

2d. 

3d. 



EVENING COLORS. *Moderato.*

1st. 

2d. 

3d. 



TATTOO. *Quick.*

1st. 

2d. 

3d. 





Early Inspection. *Slow.*

Two staves of music in 3/4 time. The first staff contains four measures of music, and the second staff contains four measures, ending with a double bar line. The melody consists of eighth and quarter notes.

Sick Call. *Quick.*

Two staves of music in 2/4 time. The first staff contains four measures, each with a triplet of eighth notes. The second staff contains four measures, ending with a double bar line. The melody features eighth and quarter notes.

Recitations. *Quick.*

Two staves of music in 2/4 time. The first staff contains six measures, with the third and fifth measures featuring a half note with a fermata. The second staff contains six measures, ending with a double bar line. The melody consists of quarter and eighth notes.

Studies. *Quick.*

Two staves of music in 2/4 time. The first staff contains four measures, and the second staff contains four measures, ending with a double bar line. The melody consists of quarter and eighth notes.

Quarters for Inspection. *Moderato.*

Two staves of music in common time (C). The first staff contains four measures, and the second staff contains four measures, ending with a double bar line. The melody consists of quarter notes.

General Quarters. *Quick.*

Two staves of music in 2/4 time. The melody consists of eighth notes and quarter notes, ending with a double bar line.

Silence. *Slow.*

One staff of music in 2/4 time, featuring a single quarter note followed by a half note with a fermata, ending with a double bar line.

Carry On. *Waltz Time.*

Two staves of music in 3/8 time. The melody features eighth notes and quarter notes with accents, ending with a double bar line.

Secure. *Quick.*

Two staves of music in 2/4 time. The melody consists of eighth notes and quarter notes, ending with a double bar line.

Dismiss. *Quick.*

Three staves of music in 6/8 time. The melody consists of eighth notes and quarter notes, ending with a double bar line.

Battalion Drill. *Quick.*

Two staves of musical notation in 2/4 time. The first staff contains four measures of music, and the second staff contains four measures, ending with a double bar line and repeat dots.

Muster Boats' Crews. *Quick.*

Two staves of musical notation in 2/4 time. The first staff contains five measures of music, and the second staff contains five measures, ending with a double bar line and repeat dots.

Rowing Exercise. *Quick.*

Two staves of musical notation in 2/4 time. The first staff contains four measures of music, and the second staff contains four measures, ending with a double bar line and repeat dots.

Change Exercise. *Quick.*

Two staves of musical notation in 6/8 time. The first staff contains three measures of music, and the second staff contains three measures, ending with a double bar line and repeat dots.

Divisional Inspection. *Moderato.*

Two staves of musical notation in 2/4 time. The first staff contains five measures of music, and the second staff contains five measures, ending with a double bar line and repeat dots.

Man and Arm Boats. Quick.



Clean Bright Work. Moderato.



Put up Cleaning Gear. Moderato.



Hook on Boats. Moderato.



Bear a Hand. Quick.



Extinguish Lights, *Slow.*

Two staves of musical notation in common time (C). The first staff begins with a treble clef and a common time signature. The melody consists of quarter and eighth notes, with some notes beamed together. The second staff continues the melody, ending with a double bar line and repeat dots.

BOAT CALLS.*

Launches.

Two staves of musical notation in common time (C). The melody is composed of eighth and quarter notes, with some beaming. The second staff ends with a double bar line and repeat dots.

Cutters.

Two staves of musical notation in 2/4 time. The melody features eighth and quarter notes, with some beaming and a triplet of eighth notes in the first measure. The second staff ends with a double bar line and repeat dots.

Whale Boat.

Two staves of musical notation in 6/8 time. The melody consists of eighth and quarter notes. The second staff ends with a double bar line and repeat dots.

Barge.

Two staves of musical notation in common time (C). The melody is composed of eighth and quarter notes, with some beaming. The second staff ends with a double bar line and repeat dots.

* NOTE-If there be more than one boat of a kind, its number is indicated by the proper number of G's following the main call.

Gig.



Dinghy.



MESS FORMATION.



HAMMOCKS.



NOTE.—One C for Starboard Watch ; Two C's for Port Watch.



[Previous Part](#)



[Seamanship
Home Page](#)



[Next Part](#)

Copyright (C) 2006 [Historic Naval Ships Association](#)

All Rights Reserved

[Legal Notices and Privacy Policy](#)

Version 1.00, 24 Apr 06

INDEX.

A.	PAGE	ANCHORING-	PAGE
Advance in turning	562	with a free wind and ebb tide	524
After sails	157	with a scant wind	523
Aground, getting	576-581	with a spring	258
ANCHOR-		Apparently drowned, to restore	595
American	230	Apparently dead, treatment of	596
advantage of lying at single	270	Articles under cognizance of	194-198
backing an	255	Bureaus	
carrying out with one boat	279-281	Astern, effect of helm when going	544
carrying out with two boats	282-284	Attraction of vessels	438-439
catting an	248	Auxiliary steering screw	574, 637
fishing an	248	Avoiding collision at anchor	525
foul	251	Avoiding dangers, steamers	547
getting off the bows	246	Awnings to douse and spread	355
heaving up an	247		
jury	234	B.	
letting go an	246	Back cloths	171
Martin's	233	" ropes	106
Mitchell's	234	Backers for head earings	127, 131, 133
mushroom	233	Backing an anchor	255
parts of an	230	" and filling	621
portable	230, 232	" off a lee shore	391, 427
Porter's	2331	" into a slip	559
purchasing an	183	Backstays cut and fitted	104, 106, 107
proof of an	232	Bad weather under steam	551
sea	211, 234-235, 480, 535	Bag racks	298
securing for sea	251	Bags	298
sheet, how	183	Bale sling	61
stocks	231	Ballast, stowage and shape	190, 191
sweeping for	286	Barometer, the	460-464
transporting an	184	Bathing, precautions	594, 595
trip hook	249	Battens, staying masts by	609
		Beckets, reefing	52, 452
		Beam scale	97-98

weighing an	247, 278, 380-394, 529, 537-538.	Bearings, relative	12-13
weighing with boats	286-287	Bell's purchase	71, 141
weights of an	232	Bending bower chain	238
which to pick up first when moored	247, 278	courses	165, 332, 504, 507
ANCHORING	246, 517-526, 535, 553	hawsers	37
beating in on a flood and by the stern	524	head sails	168, 334, 502
head on	257	light sails	168, 336
in a narrow channel	521	sail (exercise)	331-336
off exposed coasts	523, 554	sheet-chain	239
preparations for	525	spanker	169, 334
running under double reefs	518, 553	studding sails	169-170
Saratoga at Champlain	524	topsails	166, 332, 503, 505, 507
schooners	259	Bends	36-37
standing in on a wind and steamers	535	Berthing	294
with a free wind	521	Billet, form of	303
	553	Bill of health	647
	520		

664

	PAGE	BRACES--	PAGE
Bill of sale	647	carrying away	482, 483, 485
Bitting chain-cable	239-240	lead of	139-141
Bitt stopper	243	preventer	141, 450, 455
Block and block	66	Bracing in	434-436
Blocks, names of	63-66	" up	436-437
" sizes of rope and straps	67, 72, 605.	Brails	153
Block straps	67-69, 604-605	Bread room	193
Boarding vessels and wrecks	218	Breaking strains, chain and rope	603
Boat officer, duties of	215-218	Breast band	15
" salutes	214	Breechings	45
BOATS-		Bringing by after scudding	475
carrying out anchors in.	279-286	Bringing to a chain	247
boarding in	217, 218	Broaching to	474

carrying stores in	220	Brought by the lee	473
crews	293	Brown's detaching apparatus	227
detaching apparatus (Brown's, Fiske's, Wood's)	227, 228, 226	Brushes, coir.	60
equipments	200-201	Bugle calls	648
good order of	213	Bull earings	163, 451
handling under oars	203-206	" rope	343
hauling up on shore	221	Bunt jiggers	153
hoisting inboard	175-179	Buntlines	149
hoisting and lowering	201, 202	Bunts	328
management in a gale	211	BUOYS-	
management in surf	611-613	anchor	252-253
orders used in handling	203-206, 208-210.	channel	375-377
		life	447
rigs	206	mooring	253, 554-555
sailing	208-212	Bureaus of Navy Dep't.	194-196
size of	200	Burtons	73
trimming	209	" Spanish	73
towing by	217	Burton strap topsail yard	127
weighing anchors with	286-287	" lower yard	132
weights of	199	C.	
BOBSTAYS-			
carried away	485-486	Cable tier	192
how measured	101	Calculating floating powers	287
how set up	110	Calm; counterbracing	437-438
Booms	136-139	CANVAS-	
Boom brace	141	numbers of	172, 610, 611
" irons	82	tests	610, 611
" flying jib	126	use of different kinds.	172
" jib	81	CAP-	
" lower	137	to ship bowsprit	90
" rigging in and out, lower	354, 407	lower	120
" studding sail	136-139	topmast	121
" topping lifts	136, 137	Capsizing boats	212
" schooner	136, 528	CAPSTAN	245
Bowlines	150	bars, how secured	245
BOWSPRIT-		bringing chain to the	247
carried away	493	steam	261

for rams	111	Carrying away rigging	482-491
lifting	111	" away spars	492-501
parts of	81	" out anchors in boats	280-284
rigging the	110	" out kedge	279
shrouds	101	" stores	220
taking in	89	CASTING	380-394
taking in, own resources	91-92	schooners	529
Box hauling	425	under steam	547
Boxing off	432	CAT-	
		back, how rove	249

663

CAT-	PAGE		PAGE
block	64	Controllers	244
to hook the	248	Correspondence	319
to reeve the	249	Counterbracing	437
Catharpins	104	Courmes' method, diameters	629
Cathead stopper, how fitted	246	COURSES-	
Catspaw	35	to bend	165, 332
Catting anchors with cat-chain	250	fit	161
Certificate of registry	646	furl	166, 471
CHAINS-		reef	450, 452, 453
bending bower	238	set	399
" sheet	239	shift	504-505-507
bitting	239	take in	399, 471
breaking strains	603	unbend	336, 504, 507
bringing to	247	Cringles	44, 160
comparative sizes	603	"Croesus," case of the	587
getting on board	238	Crossing light yards (drill)	345
lengths of	237	" and loosing sail	347
long scope, value of	254-255	CROSSTREES-	
marks on	237	lower	113
ranging	240, 248	topmast	120-121
securing inner end	238	Cuckold's neck	46
slipping	259	Cutting and fitting rigging	97-107
surging	248	" away masts	481

sweeping for	286	out sails	159
veering, bad weather	253	Cyclones	464-470
weather biting	240		
weights of	603	D.	
Chapelling ship	433		
Charter party	647	Davit, fish	249
Chasing	553	Dead eyes	107, 606
Check stoppers	243	" to turn in	606
Circular storms	464-470	Deck stoppers	242
Clearing hawse	275	" tackle	73
Clew catchers	400	Decrease in weight, immersed	288
" jiggers	149	bodies	
" lines	148	Definitions	1-8
Clews, hammock	59	De Horsey rig for boats	207
Clinches	37	DERRICK	87, 186-188
Clothes lines	355	calculating strain on	189
Clothing	297	upright	188
Clubbing	621	DETACHING APPARATUS-	
Club hauling	422	Brown's	227
Cockbilling yards	358	Fiske's	228
Collier's purchase	257	Wood's	226
COLLISION-		DIAMETERS-	
avoiding at anchor	525	final	562-566
reports made on	377	methods of finding	629-633
rules for avoiding	360-375	tactical	562-566
steamers	553	Difference of resistance to screw	540
Coming to against the helm	432	blades	
Commands	323	Distress, assisting vessels in	218
Communicating at sea	440	Dolphins	50
Comparative effects, screw and rudder	546	Dolphin striker, to rig	123
COMPASS-		Downhauls	150
dumb	12	Draft, cutting rigging by	97
to box the	11	Drag, to use a	479
Compressors	244	Drawing frames	598
Conduct books	305	Dressing ship	356
Conning	413	Drift angle	562, 629-633
Construction stores	196	" to determine	629-633
		Drifting	620-622

664

	PAGE		PAGE
Drowned, to restore apparently	595	Flying moor, to make a	273
Drowning persons, to rescue	593	Fog signals	362-363, 378
Dry dock, to haul into	558	FOOT ROPES-	
DUTIES OF-		jib	123
boat officers	215, 317	lower	132
forecastle officer	308	topgallant	133
midshipman of berth deck	316	topsail	128
" division	317	Fore and afters, handling.	527-536
" gun deck	314	Fore and aft sails, to bend	169, 334
" hold	316	" to make up	168, 169
" quarter deck	311	Fore and aft stays fitted	102, 105-107
" top	313	" send up	114, 121, 125.
petty officers	300	" set up	116, 122, 126
topmen and others	299	Forecastle officer, duties of	308
E.		Foul anchor	251
		" hawse to clear	275
		Foxes	25, 50
EARINGS-		French reefs	162-163, 452
fitted	163	Funnel	82, 125
head, how secured	127, 165, 335	FURLING-	
reef, how passed	451	courses	166
Embarking heavy articles, boats	221	fore and aft sails	168, 169
Emergency signal	550	remarks on	328
Engineers' stores	197	sail, from a bowline	330
Engine-room signals	538, 550	sail, from a buntline	327
" Enterprise," turning trials	641	topsails	167
Equipment of boats	200	Futtock band carried away	489
" stores	196	" shrouds, how fitted	102
Equipoise rudder	94		
" how supported	94	G.	
" present value of	565		
EXERCISES-		Gaffs	135

port routine	323-355	Gaff topsail	529
under steam	567	Gale	471-482
EYE-		preparations for	472, 473
Elliott's	241	" to ride out a, in boats	211
Flemish	42	Gammoning	110
rope makers'	42	" carried away	489
spindle	43	Ganger	239
		Garland	88
F.		Garnet	74
		Gaskets	50, 164
Fenders	58	German experiments, screw	634, 636
Fid	38, 513	ships,	
preventer	349	GETTING-	
topmasts, to	122, 516	aground	576
Fighting stoppers	243	anchor off the bows	246
Fill away, to	441	chains on board	238
Finding size of shrouds	607	underway	380-395
Fire bill	302	" schooner	529
" booms	625	" steamers	537
Fish davit	249	Gin bar	121
Fishing a lower yard	499	" blocks	64
Fiske's detaching apparatus	228	Girtlines, hammock	75, 295, 355
Fitting standing rigging	110-139	" rigging	75, 112, 113, 120
Fittings of sails	160-164, 167	Glass, long and short	17, 18
Flemish horses	128	Going alongside (boats)	212
Floating power, to calculate	287	" a wharf (ships)	555-558
Flying jib, to set	402	Gold leaf, to apply	619
" to take in	403	"Gorgon," case of the	577
Flying jib boom, to get on board	126	Grafting	50
" to rig in and out,	126, 351, 352		

	PAGE		PAGE
Griquet purchase	74	Helm weather, how caused	412, 549
Gripes, boats	201	Hitches	34-36
Grommet straps	68, 604	Hitching	49
Ground log	20	HOISTING-	
Guess warp	219	boats	201
Gun tackle	75	head sails	403
" tackle purchase	72	rail launches	179
GUNS-		reefing and	449-456
backing an anchor with	256	square sails	410
getting in	180, 181	in and out boats	175-180
getting out	1811	guns	180
throwing overboard	182, 256	heavy articles	174
weighing	256	launch when underway	178
GUYS-		light articles	173
boom	153	spare spars	174
jib	106	Hold, stowage of	190-193
H.		Hooks	66
		Houseline	25
		Hull, parts of	1-8
Hackle	5P8		
Half boards	426	I.	
Half tops, to send up	113		
Halliards	141-144	Idlers	293
" (boats)	208	Immersion, decreasing weight	288
Hambroline	24	In and out jiggers	405
Hammocks	295	INSTRUCTIONS-	
Hammock clews	59	for restoring apparently dead	596
" girtlines	75, 295, 355	" drowned	595
HANDLING BOATS-		for saving drowning persons	593
under oars	203	Irons, ship in	420
under sail	208-212		
fore and afters	527-536	J.	
"Hankow" experiments	545, 627		
Haul of all	419	JACKSTAYS-	
Hauling up boats on shore	221	lower yard	132
Hawse, rope	276	reefing	128, 132
" to clear	275	topgallant yard	134

Hawsers, sizes of	240, 603	topsail yard	127
" steel	241, 603	Jacob's ladders	61, 137, 352
Head and stern, to moor	273	Jeer Blocks	65, 75
Head earings, course	163, 165, 335	Jeers	75
" topsail	163, 335	Jewsharp	231
HEAD SAILS-		JIB-	
bending	168, 335	to bend	168, 335
making up	168	gear carried away	486, 487
setting,	403	set	403
shifting	502	shift	502
stowing	168	stow	168
taking in	403, 471	take in	403, 471
unbending	337	unbend	337
HEAVING-		JIB Boom-	
down	584	carried away	496
the log	18	getting on board	123
to, boats	210	how rigged	81, 124
" fore and afters	533	to rig in	509, 515
" under sail	441	to rig out	124
under steam and sail	551	to shift	509
up an anchor	247	Jib stay, carried away	486
Heeling, effect on circle	564	" how fitted	105
Helm angles, effect on circle	565	Jiggers	75
" assists in shortening sail	411	Jumpers	406, 471
		Jumping booms	225

666

	PAGE		PAGE.
Junk	25	Lizard topmasts	514
JURY-		Logbook	458, 647
anchor	234	" line how marked	17
mast	494	" to heave the	17-18
rudder	477-479	Lookouts	304, 396-397
windlass	287	LOOSING SAIL-	
		getting underway	381
K.		to a bowline	329

		to the buntlines	326
Kackling	36	Losing spars	492-501
Kedge and toggle	394	LOWER BOOMS-	
Kedges	231	bow fitted	137
" to carry out	279	to get from under bows	409
Kedging	220	to rig in and out	354, 407
Knocked down	480	LOWER-	
Knots	31-34	brace carried away	482
Kunstaedter steering screw	574, 637-638	cap to ship	120
		lift carried away	488
L.		lifts how fitted	131
		mast, carried away	494
Laniards, rigging.	110-111	" iron	83
LAUNCHES-		" wooden	80-81
carried on rail	179	masthead pendants	98
hoisting inboard	175	rigging how fitted	98-103
weighing anchor with	286	" how set up	116-117
Laws of storms	464-469	stays, how fitted,	101-102
LEAD	14-16	LOWER YARD	82
deep sea	15	fishing	499
to heave the	14-16	fittings	82, 131
Lead line, how marked	14	getting inside rigging	498
Lead of gear, altering	154	getting on board	130
Leaks	582	sending down	515
Leech lines	152	sending up	132, 516
Lee, brought by the	473	shoring up	186
" shore getting under way from.	386-391	used as a derrick	187
Letting go an anchor	246	Lowering boats	201, 444-447
LIFE BOAT-		Luff tackles	72, 75
" handling	222	Lug sails	206
" manning	446	" to dip	206-207
buoys	447	LYING TO-	
lines	358	fore and afters	534
saving service, U. S.	588-593	steamers	551
Lifting bowsprit	111	under sail	472
LIFTS-			
carried away	488	M.	

fitting lower	131	Main brace carried away	482
" topgallant	134	" yard, leaving square in stays	430, 446
" topping	136, 137, 528	MAKING SAIL-	
" topsail	129	detail	398
LIGHT SAILS	157	exercise	338
To bend	168, 336	in getting underway	381, 383
to unbend.	337, 349	MAN OVERBOARD-	
Light yards, exercise of	343	schooners	534
to send down, bad weather	472	under sail	444-446
Lights, vessels	360	under steam	550
Linings, sails	160	Management of boats in surf	611
Little's method for diameters	631	Manifest	647
Lizard light yards	133, 345	Manning yards	357
" topgallant masts	349	Marline	25
		Marline spike	38

667

	PAGE	OARS-	PAGE
Martingale	106, 123, 406	and sails	210
Martin's anchors	233	steering with an	200, 612
Masthead pendant tackles	185	Officer of the deck, the	395
Masting	84-92	Open boats, management in surf	611
MASTS	80-84	Ordnance stores	197
boat's	207	Organization	289
cutting away	481	Outfits under different Bureaus	196-198
how secured before staying	114	Outhauls	151
standing of	115	Overboard, man.	444, 534, 550
staying by use of battens	609		
MATE OF-		P.	
berth deck, duties	316		
gundeck, duties	314	Pacific irons	82
hold, duties	316	Painter, boat's	201
Measuring for rigging	99-107	" shank	246
Medical stores	198	Painting ship	618-619
" Melrose" experiments	545	Parbuckle	61, 85
Mending sail	331	" counter	85

Mensing's method for diameters	631	Parcelling	47
Messenger	245	PARREL-	
Messing	296	carried away	485, 487
Metallic robands	335	topgallant	133
" splices	108	topsail	128
MIDSHIPMAN OF-		Parting rigging	482-491
boat (armed)	317	Passport	646
division	317	Paymaster's stores	197
quarter deck	311	Petty officers' duties	289, 300
top	313	Picking tip moorings	253
Miscellaneous routine	614	Plan of holds	190
Missing stays	419	Pointing	49
Mitchell's anchor	234	Portable anchors	232
Mix stopper	243	Port routine, exercises	323-355
Moor flying	273	Power gained by tackles	70-72
MOORING-		PREPARATIONS-	
at a wharf	555-557	for anchoring	246, 517-520
head and stern	273	" entering port	518
in a tideway	272	heavy weather	472
preparations for	269	" mooring	270-271
ship	268-274	" sea	615
swivel to put on	278	Principal parts of ship	1-8
to a buoy	555	Proof of anchors	232
Moorings, picking up	253	" chains	237, 603
"Monongahela," case of	579	Proportion of straps to blocks	605
Mousing a hook	60	Provisions, stowage of	191
Mushroom anchor	233	Purchase, sheer	86
Muster roll	647	Purchases, see TACKLES.	
		Purchasing guns	180-183, 186
N.		" heavy weights	174, 186
		" waist anchors	183
Nautical terms	1-8	Putting on mooring swivel	278
Navigation stores	197		
Navy Yard moorings	557	Q.	
" organization	196		
Nets	58		
Nettings	62	Qualities of anchors	233
Nettles	25, 26	QUARTER-	

Nippering	47	bill	301
Nippers	241, 245	blocks, lower yard	131
		" topgallant yard	133
O.		" topsail yard	127
		irons	132
OARS	199	"Quinnebaug" turning trials	639
handling boats under	203		

668

R.	PAGE	ROPE-	PAGE
Racing	543	hide	23
Ranging chain	240	lengthening with a strand	40
Ratline stuff	24	manilla	23
Rattling down	118	manufacture of	598
Receiving crew on board	303	shortening in the centre	41
Reducing sail to a squall	211, 442, 533, 551	size for block, to find	29, 605
Relation of power to weight	70-72	strength	27, 29, 603
Relative bearings	12-13	tapered	23
REEF-		twice-laid	23
earings	163	varieties of	22-24
to pass, earings	451	weight of	29
tackle carried away	483	wire	24
tackles	76, 152, 449	Roping	24,162
REEFING-		Ropemaker's winch	26
beckets	52, 451	Rope making	598
boats' sails	210	Roundline	24
a course	450	Routine, miscellaneous	305, 614
on the foot	506	Royal shrouds and stays	104, 125
schooners' sails	533	Royals, to set and take in	402
spanker	456	ROYAL YARDS-	
topsails	449	to fit	134
trysail	456	to exercise	343-349
REEFS-		sending down, bad weather,	472
French	162	RUDDER-	92
to round to under	452	backchains for	95
to shake out	452	boats', to ship easily	200

Relieving tackles	476	effects, screw steamers	544
Reports of collision	377	equipoise	94, 565
Reporting for duty	320	gone	476
Restoration of app. drowned.	595, 597	how supported	94
" dead	596	jury	477-479
Reverse effect of rudder	533-546	to ship	93
Reversing valve (windlass)	266	to steer without	476, 487
Riding to leeward	624	Rules of the road	360-379
" windward	623	Runners	72
Rig of boats	206	Running lights	360
" vessels	9-10	" rigging	139-155
RIGGING-		S.	
cut by draft	97		
cutting and fitting	97-107		
lower	98-103, 113-115	Saddle	135
names of parts	9	SAIL-	
of head booms	106, 123, 126	bending	164-169
royal	125	" port routine	331
running	139-155	covers	171
setting up	116-122	furling from a bowline	330
ship	110-155	the buntlines	327
topgallant	125	loosing to a bowline	329
topmast	121-122	" the buntlines	326
Rigging screws	607	" and crossing yards	347
Right-handed screw	539	making	338, 381. 383
Ring stopper	242, 247	making, detail	398-409
Rolling tackles	180	mending	331
ROPE-	21-30	room	193
backhanded	22	shortening	330, 340, 520
bolt	24	tackle	76
breaking strains of	29, 603	unbending	336, 348
cable-laid	22	" and sending down yds.	348
comparative sizes	29, 603	Sailing, boats	209
		SAILS	156-172
		advantage of setting flat	158

SAILS-	PAGE		PAGE
boats	206	Sheet-chain, bending	239
cutting out	159	getting on board	238
fittings of	160-164, 167	Sheets	144-147
fore and aft	169	Shift of wind	432-434
head, to set and take in	403, 471	SHIFTING-	
names of	9	a course	504, 507
parts of	156	" heavy weather	504
shifting, blowy weather	504-507	" in chase	507
" in chase	507	jib	502
square	156, 409	studding sail boom	508
studding	156-157	topgallant mast	510
Salutes, boats	214	" sail	508
Schooners, handling	527-536	topmast	513
" rig of	527-529	topsail	503-507
Scraping spars	618	" heavy weather	505
Screw, effect on turning	540-543	" in chase	507
" right-handed	539	" yard	511
SCREW-		Ship on her beam ends	480
current due to slip	543	" the, definitions	1-8
effect in backing	541	Shipping articles	647
" on rudder	541	Ship's papers	646-647
Scudding	473	Shoring up lower yard	186
SEA-		" ship when aground	579
anchor	211, 234, 480, 535	Shortening sail coming to anchor	520
letter	647	" exercise	340
preparing for	615-617	" loosed to a bowline	330
terms	1-8	SHROUDS-	
Seams of sails	159	carried away	489
Securing boats for sea.	201, 616	cutting and fitting	97-107
" bower "	251	futtock	102
Seizings	45-47	measuring for	99,101, 103, 104
Selvagees	51	rule for size of	607
SENDING DOWN-		to send aloft	113
damaged spars	492-501	to set up bowsprit	110
light spars (drill)	353	" lower	116
light and unbending sail	348	" topmast	122
light yards	346	Side-tackle	76

split sails	502-508	Siegel's method for diameters	632
topgallant masts	350, 551	Signals, fog	362-363, 378
Sennit	53-54	to engine room	538, 550
" for hats	59	Silence, call for	306
Service	47-48	Size of shrouds, rules for	607
SETTING UP-		" relative, of rope and chain	29, 603
bobstays	110	Sliding gunter mast and rig	206
rigging	116, 122	SLINGS-	
stays	116, 122	gun	60
Shackle, anchor	231	hogshead	60
" pins	237	preventer	83
Shackles, chain	237	lower yard	83, 131
Shaking out reefs	452	Sling to, a cask	61.
Shakings	26	" cask with head knocked in	61
Shank painter	247-248	Slip, backing into a	559
Sheave and pin	63	" stoppers	243
Sheep shank	35	Slipping a chain	259
Sheer pole	116	Sloops, handling	530-534
Sheers to dismantle	91	" rig of	529
" to raise	87	Small store requisitions	296
SHEET ANCHOR-		Small stuff	24
purchasing	183	Snaking	49, 62
securing	183	Snorters	134
transporting	184	Sounding, under sail	15, 448

670

	PAGE	STEAMERS-	PAGE
Soundings under steam	551	altering lead of gear	154
Sounding machine, Tanner's	645	coming to anchor	553
SPANKER-		getting under way	537
to bend	169, 334	handling in squalls	551
" furl	169	lights	366
" reef	456	lying to, heavy weather	551
" set	403	making sail on	549
" take in	403	man overboard	550,
" unbend	337	mooring to a buoy	553-554

Spanish burtons	73	" wharf	555-557
" foxes	25,50	tacking	549-550.
" windlass	45	taking in tow	551, 560
Spare anchor to transport	185	turning	561-569
" spars to get on board	174	Steaming up to anchors	256
" to stow	175	Steerers, steam	569-573
Spars, names of	9	" value of	573.
" to tow	218	STEERING	412
Sp. Taxes	25, 50	and trimming boats	209
Speed indicator	19	oar, how fitted	200
SPLICING	37-44	with a drag	477
bench	107	with a hawser	476
wire rope	108	with a jury rudder	477-479
Splitting sails	502	Stocks of anchors	231
Spreader	598	STOPPERS	33-34, 242-244
Spreading awnings	355	cathead	246
Spring, anchoring with a	258	fighting	243
" casting from	386, 391, 393, 555	for cable	242-244
Spun yarn	25	Stopping leaks	583
Spur shores	557	" steamers	147, 574
SQUALLS	442-444	Store rooms	592-193
handling boats in	211	Stores, carrying in boats	220
" fore and afters in	533	" hoisting on board	173
reducing sail to	442	Storm sails	157
under sail to receive	442	Storms, laws of	464-469
" steam "	551	Stowage	190-194
Squaring yards	341	Stowing head sails	168
Standing of masts	115	" spare spars	175
rigging	96-108	Straps, rules for size of	67, 604
Station bill	302	Strapping blocks	67-69
Staying of masts	115	" Stratheden" experiments	637
" by use of battens	609	Stress on derricks	189
STAYS-		STUDDING SAIL BOOMS	137-138
carried away	486-487	to get from under bows	409
lower, to fit	101-102	how fitted	137-138
" to send aloft	114	jumper for	406
" to set up	116	rigging in and out	137
missing	419	sending aloft	138

topmast, to fit	105	shifting	508
" to set up	122	STUDDING SAILS-	
Staysails, to set and take in	405	to bend	170
STEAM AND SAIL	548	" dip	408
capstan, Lancaster	260	" make up	170
handling vessels under	537-575	" set	405-408
launches, hints on	223	" take in	405-408
windlass, Trenton	262	Sunstroke, treatment of	596
STEAM STEERER-		Supporting lower yards	174
Baird's	573	Surf, management of boats in	611
Manton's	572	Surging chain	248
Sickel's	569	Sweeping for anchors	285
value of	573	" chains	286
		Swiftering in slack rigging	496

671

	PAGE	TOP GALLANT-	PAGE
Swiftering in to rattle down	118	mast rig	125
Swigging off	79	" send down (gale)	551
SWIVELS-		" (exercise)	350
in chain	237	" send up	124, 510
mooring, to put on	278	" (exercise)	352
use of	237	" shift	510
Sword mats	54-58	TOP GALLANT SAIL-	
		bend	168, 336
T.		furl	402
		set	401
Tack, carried away	484	shift	508
TACKING	415	take in	402
boats	209	unbend	337, 349
fore and afters	530-531	TOP GALLANT STUDDING	
steamers	549	8AIL-	
under double reefs	421	bend	170
with a drag	421	dip	408
Tackles, names and uses	70-79	make up	170
" power gained	70-72, 78	set	404
		take in	405

Tacks	147-148.	boom, fittings of	138
Tactical diameter, how found	629-633	TOP GALLANT YARD-	
Taffrail log	19	carried away	496
Tail block	69	cross	134
Taken aback	432-434	cross (exercise)	345
" in tow	217, 431, 551, 560	cross and loose sail	347
		get on board	133
Tank toggle	611	rig	133-134
TAKING IN SAIL		send down (gale)	472
(detail)	398-410	send down (exercise)	346
bowsprit	89	TOPMAST	82
mizzen mast	88-89	cap to ship	121
TAKING IN Tow-		carried away	495
boats	217	cross trees, to send up	120-121
under sail	431	fid	119, 514, 516
under steam	551	get on board	119
Tanner's sounding machine	645	house	515
Tarring down	618	rig	121
" yarns	599	rigging fitted	103-104
Tending ship at single anchor	622	rigging set up	122
" when moored	275	send down	515
"Tennessee" turning trials	643	shift	513
Tension to be given rigging	117	wreck, to send down	495
" stays	117	TOPMAST STUDDING SAIL-	
Terms, nautical	1-8	to bend	170
TESTS-		make up	170
of anchors	232	set	405
canvas	610-611	take in	406
chain	237, 603	boom, to rig	137
rope	603	" rig in and out	405
Thimbles, to splice in	108	" send aloft	137
Tides	387	" shift	508
Tideway, in under sail	620	Tops, to send up	112
Tierers	238	half, to send up	113
Tiller rope carried away	487	Topsail brace, panel, reef-tackle,	483-487
Timenoguy	140	sheet carried away	
TOP GALLANT-		TOPSAIL-	
brace and parrel carried away	485	bend	166

lift to clear	346	" exercise	332-336
rigging, to fit	104	gear of	161
rigging, to set up	125	furl	167
mast carried away	495	make up	166
" get on board	124		

672

TOPSAIL-	PAGE		PAGE
names of parts	160	Unmooring	274
reef	449, 452, 453	Upright derrick	188
set	400-401	U. S. pilot rules	368
shift	503, 505, 507		
take in	400-401	V.	
unbend	337, 504		
schooner	535	Value of a long scope	254, 255
yard	82	" steam steerers	573
" carried away	497	Vangs	135
" get on board	126-127	Veering chain	254
" rig	127	Vessels' lights	360
" send down	511		
" send up	130, 512	W.	
" shift	511		
TOWING AT SEA-		Waist anchors, purchasing	183
sail	431	" transporting	184
steam	551	Warp, guess	219
in port, boats	217	Warping	219
" tugs	560	Wash deck gear	192, 310, 614
vessels on fire	218	Watch bill	291
Transfer in turning	562	Watches	304
Transporting spare anchor	185	Water whips	77
waist "	184	WEARING	423-426
Treatment of apparently drowned	595	boats	210
" dead	596	fore and afters	531
Trestle trees carried away	497	in a gale	424, 425
" send up	112	short around	426
Triatic stay	175	under bare poles	425

Tricing lines, boom	138	WEATHER-	
Trimming yards	418	bitting a chain	240
Trip hook	249	helm, steamers	549
Trumpet, the	323	the	457-463
Truss carried away	488	WEIGHING-	
" how fitted	82, 131	an anchor with a boat	286
TRYSAIL-		guns	256
bend	169	notes on	380, 394
furl	169	with several anchors down	256
mast, how fitted	135	WEIGHT-	
reef	456	of anchors	232
set	404	boats	199
take in	404	chain	237, 603
unbend	337	rope	28, 29, 603
Turks head	51	Wheel ropes	23
Turning agencies screw vessels	538	" carried away	487
" effect of screw	540-534	" crossed	379
" rudder	544	Whipping	48
" experiments	561, 627	Whips	72
Turning in dead eyes	606	Whiskers, to rig	124
Twin screw, effect in turning	539, 567	Winch, rope makers'	26
Twine, sail	22, 159	Wind and sea, effect on steamer	547
Tyes, topsail	129	" weather, record of	458
		" table of velocities	459
U.		Winding pendants	178
		Windlass	246
Unbending sail, exercise	336	" Spanish	45
" in heavy weather	504	" steam	262
Under sail and oars	210	Wing and wing	532
Under way, to get, fore and afters	529	Wings, stowage of	191,192
" under sail	380-395	Wire cables	241
" steam	537	" rigging	96-109
		" rope	24

	PAGE	YARD-	PAGE
Wire rope making	601	royal, to send up	135
Wood's detaching apparatus	226	slings	83, 131
Working to windward with a tow	423	tackles	77
Worming	47	topgallant carried away	496
Wyckoff's method, diameters	630	" to cross	134, 345
		rig	133
Y		send down	346, 472
		topsail carried away	497
Yacht sails	536	" to get aboard	126-127
YARD-		" rig	127
lower to fish	499	" send down	511
" get aboard	130	" send up	130, 512
" rig	131	YARDS-	
" secure	174	cock billing	358
" send down	498, 515	exercising light	343-349
" send up	132, 516	manning	357
royal, to cross	345	squaring	341
rig	134	Yards and Docks, bureau	194
" send down	346, 471	Yarn	22
		Yeoman's storeroom	192



[Previous Part](#)



[Seamanship
Home Page](#)

Copyright (C) 2006 [Historic Naval Ships Association](#)

All Rights Reserved

[Legal Notices and Privacy Policy](#)

Version 1.00, 24 Apr 06