

NOTES ON
CHRONIC OTORRHŒA

WITH ESPECIAL REFERENCE TO THE
USE OF ZINC IONIZATION IN THE
TREATMENT OF SELECTED CASES

BY

A. R. FRIEL,

M.A., M.D. (UNIV. DUB.), F.R.C.S.I.

*An Assistant Aurist, School Medical Service, London County Council ;
Aurist to Tottenham, Hornsey, and Walthamstow Education Committees.*

BRISTOL : JOHN WRIGHT AND SONS LTD.

LONDON : SIMPKIN MARSHALL LTD.

NEW YORK : WILLIAM WOOD AND COMPANY

1929

PRINTED IN ENGLAND BY
JOHN WRIGHT AND SONS, LTD., BRISTOL

PREFACE.

To Professor Leduc, of Nantes, doctors and patients owe a debt of gratitude owing to the results which have been obtained by the application of his discoveries to the treatment of certain diseases : doctors, because they have been able to free many patients from local maladies ; and patients, because they have been relieved of these disabilities. This book is devoted to the consideration of one such local disease—chronic otorrhœa. It tries to answer two questions : (1) How is any particular case of chronic otorrhœa to be treated ? (2) How are we to deal in an economical manner with the large number of cases needing treatment among elementary school children in the large towns ?

With regard to the first question, the method of diagnosing the cause of chronicity is discussed, and the technique of treatment, especially that by zinc ionization, is described. To make this intelligible a short account is given of what is meant by ionization, and some laboratory experiments are also described to make clear how zinc ionization acts in cases of local sepsis.

In answering the second question, the organization which has been found useful in the aural clinics of the school medical service is stated in some detail. Outside the clinic itself many people take their share of work in promoting the recovery of the child : medical officers of the Board of Education, school medical officers and Education Committees who have worked to provide facilities for treatment : school doctors, teachers, and nurses who send patients to the Ionization Clinics ; the organizing staff attached to these clinics ; and members of the Care Committees who visit the children's homes and interview the parents to ensure that the children attend regularly.

For the large share he took in the establishment of the first ionization clinic for chronic otorrhœa the writer is much indebted to Dr. Eichholz, Chief Medical Inspector of the Board of Education, and later on, for promoting extension of the work, to Dr. Sophia Jevons. He owes much for the smooth working of this clinic to Miss McCaul, and for help in carrying out the treatment to Miss Eames.

The writer is much indebted to Dr. Chaikin, Divisional Medical Officer of the London County Council, for wise advice ; and to Dr. Wells, Senior Aurist to the L.C.C., for constant friendly help and co-operation. The Council, however, accepts no responsibility for the author's opinions or conclusions.

A. R. FRIEL.

London, 1929.

NOTES ON CHRONIC OTORRHŒA

PART I.

THE RÔLE OF THE ELECTRIC CURRENT AND ZINC IONS IN THE TREATMENT OF SEPTIC SURFACES.

CHAPTER I.

DISTINCTION BETWEEN ACUTE AND CHRONIC SUPPURATION OF THE MIDDLE EAR—THE PRINCIPLES OF TREATMENT IN EACH CONDITION.

ACUTE suppurative otitis media and chronic suppurative otitis media are two distinct diseases, although the latter is preceded by the former. The essential factor in both is bacterial infection.

When an individual is attacked by scarlatina, measles, influenza, etc., the nose and throat are infected by a micro-organism and the infection frequently passes up the Eustachian tube and involves the middle ear. Its presence there is shown by inflammation accompanied by pain, rise of temperature, exudation of fluid, deafness. Frequently perforation of the drumhead occurs, serous discharge appearing in the external auditory meatus and running out of the ear. If this discharge is examined microscopically it will show some red and white blood-cells and a number of micro-organisms of one variety, such as a streptococcus or a pneumococcus. Sir Almroth Wright showed (*Lancet*, 1915, i, 740) that serum in which leucocytes were disintegrating underwent a change by which it became a good culture medium for saprophytic micro-organisms. Consequently this *discharge* after the leucocytes have died can be readily infected by micro-organisms present on the skin of the meatus or introduced from outside. As

long as the discharge is profuse this does not matter much, for before they can develop they have been carried away by the exudation fluid streaming from the ear. As the patient is recovering, the inflammation of the tissues subsides and the discharge becomes less, and stagnates in the tympanum and in the meatus; the leucocytes die, and there is time for micro-organisms added from the skin to develop in the ear, with the result that the discharge now forms an irritating fluid in contact with the tissues. The latter respond to the irritation of this fluid by secreting more cells and serum, and so the process goes on and chronicity is established.

Dr. R. H. Woods (now Sir R. H. Woods) had pointed out in 1898 the essential difference in the bacteriological flora of acute and chronic suppurative otitis media, and attributed the cause of chronicity to the establishment of the additional organisms in the tympanum (*Dublin Journal of Medical Science*, 1898).

When a man breaks his leg he is undoubtedly suffering from the effects of an injury, and when a patient has an attack of influenza involving the throat and middle ear he is likewise suffering from an injury. As long as the skin of the man's leg is not broken, repair proceeds with little, if any, constitutional disturbance; but if the skin is broken, and if micro-organisms which can grow in the effused blood gain entrance, the man begins to suffer from sepsis, which is quite a different disease and is added on to the effects of the injury.

In the case of the ear, when the individual has an attack of acute inflammation he has an infection of his tissues. These respond; there is vascular dilatation, leucocytosis, and exudation, followed by the development of antibacterial properties in the blood. In a few days the body gains the upper hand and the bacteria are banished. Repair, as in the case of the broken leg, goes on quickly provided some new factor is not added. In the ear the new factor which may be added is the *infection of the discharge* by saprophytes. Immunity has been developed by the patient to the *original* invading organism, but not to the bacteria added to the discharge from the external auditory meatus.

As regards treatment, most people are agreed on the general principles. In the acute state we keep the patient at rest, in bed if possible, in order to conserve his energy and allow it to be devoted to fighting the bacteria. Warmth is applied locally to ease the pain, and if necessary we supplement this by something to make the patient sleep. After the drumhead has been incised, or has ruptured, and discharge has appeared in the meatus, we encourage a flow of fluid from the ear as well as try to prevent the development of micro-organisms in the discharge by instilling into the ear at frequent intervals glycerin containing 1 per cent of carbolic acid. When the discharge diminishes we take special care to remove it by absorption, either with antiseptic gauze placed in the meatus, or by boracic powder blown into it. In the latter case the discharge is taken up among the particles of powder and dried, and it is owing to this and to the antiseptic action of the powder that it becomes a poor culture medium. In a short time the discharge ceases altogether and the patient has recovered.

If these precautions have been neglected, and additional organisms have gained access, so that chronicity has been established, we find an accumulation of septic irritating fluid in the middle ear. The indications are to remove the gross accumulation from its cavity, and then to disinfect its surface, to which a layer of exudation adheres, microscopic in thickness and containing various species of bacteria. The gross accumulation can be removed by mechanical means, but the film of microscopic thickness cannot. Experience shows that disinfection may be secured in more than one way. If the discharge is very slight in amount, or is distinctly mucoid in character; if the area from which it comes is accessible, and there is no factor except sepsis in the ear keeping it up, boracic powder insufflated into the tympanum absorbs the discharge, desiccates it, and renders it a bad culture medium for bacteria. The irritation of the tissues is thereby limited and the discharge usually ceases at once. But this method of treatment is not rapidly successful where the discharge is more profuse or where the tissues are red and swollen. If

the septic area is accessible, zinc ionization enables us to protect the tissues by forming an antiseptic barrier between the tissues and the external world. The barrier by its antiseptic property restrains the activity of bacteria, and by its physical property protects the tissues from external agents. Rest is then afforded to the irritated tissues and the discharge rapidly ceases. Our treatment is handmaid to the *vis medicatrix naturæ*.

CHAPTER II.

THE CHEMICAL ATOM—DISSOCIATION OF MOLECULES OF A SALT—THE NATURE OF THE ELECTRIC CURRENT IN (a) A WIRE, (b) A SOLUTION OF A SALT IN WATER—ELECTRONS—IONS.

To understand the treatment called ionization it is necessary first to take account of the recent discoveries in the composition of the chemical atom, of the nature of the electric current and of the general constitution of the chemical compounds known as salts, and of a remarkable property which they, as well as acids and bases, possess.

It is now known that the chemical atom is made up of particles of positive and negative electricity. These are present in such amounts that they exactly neutralize each other. The number of particles of negative electricity, called *electrons*, is definite for the atom of each element. In the case of certain elements—the metals and hydrogen—the electrons are, in the special circumstance described below, diminished; and in the case of some other elements—chlorine, iodine, bromine, and such groups as SO_4 , NO_3 —the number of electrons is increased.

The molecule of every salt has two component groups. In the case of inorganic salts one group is a metal, and the other is an element such as Cl, I, Br, or a group of elements such as SO_4 , NO_3 , etc. In the case of organic salts one or other or both groups can be a composite group, as in the salts sulphate of quinine or salicylate of soda.

A metal when it forms one group in a salt, as silver in silver nitrate, is not present as a neutral atom. It has lost an electron.* It has then an excess of positive electricity. Similarly in organic compounds, when a complex occupies the place of the metal, as in quinine sulphate, the complex

* When an atom is capable of taking on (or losing) one electron we say the atom is monovalent; when two, it is divalent, etc.

quinine has a positive excess or charge. Chlorine, bromine, iodine, and such complexes as SO_4 , NO_3 , form the other group in salts, e.g., chloride of sodium, zinc sulphate, sodium salicylate. They are not present as neutral atoms or neutral complexes, but have all gained one or more electrons. Chlorine, bromine, and iodine have one in excess, while SO_4 has two. They therefore possess a negative charge.

The electrically charged groups of a salt are called ions. Salts (as well as acids* and bases) are formed by the union of positive and negative ions.

In the table of salts below, the positive ion is underneath the sign +, and the negative under the sign —.

+	—
Sodium	Chloride
Zinc	Sulphate
Adrenalin	Chloride
Quinine	Sulphate
Sodium	Salicylate
Silver	Nitrate
Lead	Acetate

When the salt is in the solid form the union between the ions is firm, but it has been discovered that when a salt is dissolved in water that firm union is broken and a proportion of the salt splits up, or dissociates, into its constituent ions. These ions preserve their electrical character, being either positively or negatively charged. They can move independently in the water, but an individual ion cannot pass out of solution without ions of equivalent value of opposite electrical condition also passing out of solution.

A voltaic cell is a chemical device for obtaining an electric current, or in other words a stream of electrons. In its simplest form it consists of a plate of zinc and another of copper dipping into dilute sulphuric acid and joined externally by a wire (*Fig. 1*).

The acid and the zinc interact—atoms of zinc go into solution, becoming ions and displacing hydrogen ions from the

* An acid can be regarded as a salt in which hydrogen takes the place of the metal; a base as a salt in which the place of chlorine, SO_4 , etc., is taken by the group OH (hydroxyl).

acid. As the atoms of zinc become ions they part with electrons which accumulate on the zinc plate, then pass along the wire to the copper plate and combine with hydrogen ions in the solution, making them neutral atoms. These in a short time are present in sufficient quantity to form visible bubbles of gas on the surface of the copper plate.

The actions above described only take place when the zinc and copper plates are joined by a wire or some other conductor.

Consider now what will happen if we interpose in the path of the current a solution of a salt in water, by cutting across

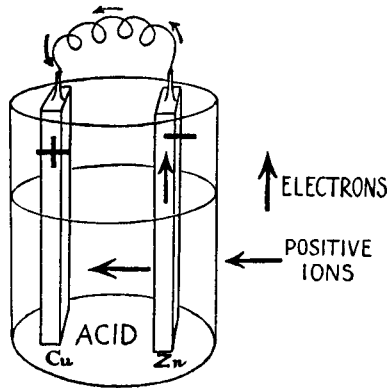

FIG. 1.—The voltaic cell.

Cu, Copper plate; *Zn*, Zinc plate.

The current in the wire is a stream of electrons, and in the dilute acid a stream of positive ions. Both start at the zinc plate and travel towards the copper plate.

the wire which goes from the zinc to the copper plate and dipping its free ends into the solution of the salt.

The salt, by its dissolution in water, has been split up to a greater or less extent into its two component ions. We know that electricity of one kind, or a body which has a charge of one kind of electricity, attracts a body which has a charge of the opposite kind. The electrons (i.e., the particles of *negative* electricity) coming from the zinc plate attract the ions in the solution which show an excess of *positive* electricity, combine with them, and convert them into *neutral atoms*.

These* pass out of, or tend to pass out of, solution. At the same time a number of negative ions, equivalent in value to the positive ions which have combined with electrons, give up their excess of electrons to the wire leading to the copper plate, become *neutral atoms*, and pass out of, or tend to pass out of, solution.

In the vessel containing the solution of the salt there is a stream of positive ions moving towards the end of the wire coming from the zinc plate, and a stream of negative ions moving towards the end of the wire from the copper plate.

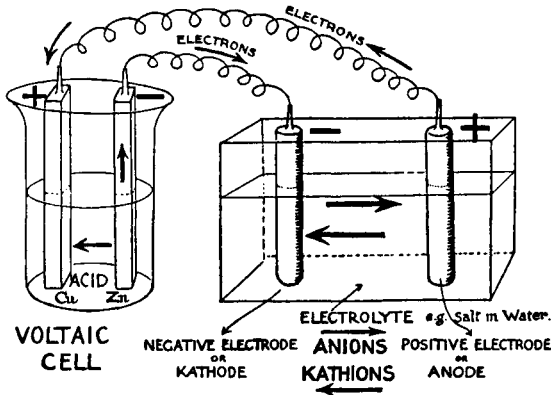

FIG. 2.

The current in the solution of the salt in water consists of two streams of ions moving in opposite directions.

They are streams of what is called *matter*, since they are streams of atoms or atom complexes which have been altered by having lost or gained one or more electrons.

The copper plate of a galvanic cell is called the positive plate, and the zinc plate the negative, because it was believed years ago that an electric current in the wire consisted of positive electricity and started at the copper plate. The solution of the salt in water is called the 'electrolyte', and the ends of the wires dipping into this solution are called the 'electrodes'. The end of the wire from the copper

* See page 13.

plate was called the positive electrode, while the end of the wire from the zinc plate was called the negative electrode. As the electric current was supposed to flow towards the zinc plate of the battery, the ions, moving in this direction in the solution of a salt, were regarded as moving down stream and were often called 'kations', and the electrode towards which they moved was often called the *kathode*, from Greek words meaning 'downway'; while the ions moving in the reverse direction were supposed to be moving up stream and were therefore often called 'anions', and the electrode towards which they moved the *anode*, from Greek words meaning 'upway' (*Fig. 2*). These names are convenient and are still retained, although we now know that the current generated by a galvanic cell is one of electrons, i.e., negative electricity, and that it starts at the zinc plate.

The ions of metals are kations, are positive, and they travel towards the kathode; while the ions of chlorine, iodine, SO_4 , etc., are anions, are negative, and travel towards the anode.

Note.—Faraday, who lived 1791–1867, laid the foundation of our knowledge of the action of the electric current on a solution of a salt in water, and he 'coined' various terms which are in general use: electrolysis, electrolyte, ion, electrode, etc. Electrolysis refers to the unloosing or setting free at the electrodes of substances in solution which he called 'ions' or travellers, owing to their movement towards one or other electrode. The solution of the salt he called the electrolyte, and the plates dipping into the solution by which the current arrived at or departed from the solution he called electrodes.

CHAPTER III.

CHEMICAL REACTIONS BETWEEN IONS IN VITRO AND IN VIVO—THE RÔLE OF THE ELECTRIC CURRENT—ACTION AT THE ELECTRODES.

It frequently happens that, when a solution of one salt is poured into a solution of another salt, chemical reactions take place. Familiar examples are the reactions which occur when a few drops of nitrate of silver in water are let fall into a solution of common salt; when a solution of salicylate of

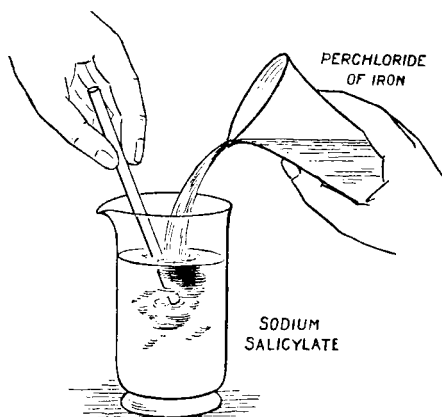

FIG. 3.

soda is added to one of perchloride of iron (*Fig. 3*); or when a little sulphate of zinc solution is mixed with blood serum or white of egg. The reactions which take place are between the ions which have arisen from the splitting up of molecules. Thus the silver ion combines with the chlorine ion to form chloride of silver. This, being an insoluble body, goes out of solution and we see it gradually fall to the bottom of the vessel as a white cloud. The salicyl ion combines with the iron ion to form a compound of a deep-red colour, and unless

the solutions are dilute the fluid becomes a jelly. Again, the zinc ion combines with a portion of the albumin molecule and forms a white coagulum. The agent which brought the ions into contact was mechanical. The experimenter pours, for example, one solution into the other, or he may have mixed with a glass rod some drops of one solution with some drops of another on a glass plate.

Similar reactions result from the mixing of ions if an electric current is used to make them travel from a solution of one salt into a solution of another salt.

In *Fig. 4* there are three vessels united by U-tubes. The vessels are filled with tap water. Salicylate of soda is added to the two on the left and perchloride of iron to the one on the right. An iron wire dips into the latter and is connected

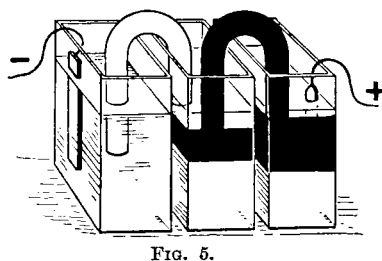
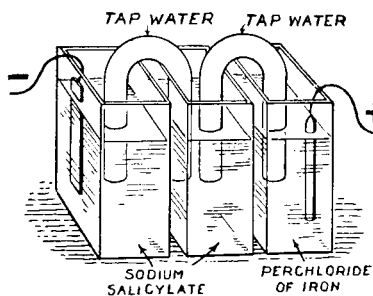

to the positive terminal of a battery. A wire of any metal or a carbon rod connected to the negative terminal dips into the vessel on the left.

Before the current is turned on the solution of salicylate of soda is colourless, that of perchloride of iron slightly yellow. After the current has flowed for some time the solutions become deep purple (*Fig. 5*). Two vessels are used at the negative side in all these experiments to avoid alkaline* (OH) ions formed at the negative electrode reaching the place where the changes occur which the experiment is designed to show.

The tissues of our body are electrolytes, since they contain

* See page 13.

salts dissolved in water. Naturally we cannot pour a solution of iodide of potash or sulphate of zinc *into* our tissues and mix them together by mechanical means. If, however, we apply solutions of them to the skin underneath electrodes, we can make the ions of these salts enter our tissues and mingle with them. The positive ion, zinc, enters under the electrode attached to the positive terminal of the battery, and the negative ion, iodine, under the electrode attached to the negative terminal. Both positive and negative ions of a salt are not introduced at the same place at the same time, as occurs, for example, when a solution of nitrate of silver is poured into another solution.

It is an advantage from the point of view of treatment to be able to introduce one group of a salt at the seat of disease,—for example the zinc ion—and not the whole salt zinc sulphate, for it is solely the zinc ion which causes the coagulation of the albumin.

Although the therapeutic effect is mainly to be attributed, in such cases as the treatment of tympanic sepsis by zinc ionization, to the ion zinc, we must not forget that at the same place an equivalent amount of ions of opposite electrical charge passes out of the tissues. The passage out of these ions—Cl for example—possibly has some effect on the nutrition of the tissues. Under the indifferent electrode there is also the same moving out of ions K, Na, etc.

At the seat of disease we use a small electrode, with the object of concentrating the introduction as much as possible, and confining the effect of the introduced ion, e.g., zinc, to this area alone, without encroaching on neighbouring areas; whereas at the distant part, where we complete the circuit with the application of the indifferent electrode, we use a large electrode to diffuse the amount of introduced and removed ions over a large area, and so produce as little effect as possible on the tissues underneath.

The treatment which we give the patient is in many cases treatment by a component of a drug which has been used for centuries; but the agent by which we convey a component of it into the tissues, and the method by which we do so,

have only been made clear in recent years. Every medical man is familiar with the salts used in ionization treatment, and uses them, but many men look askance at the method of introducing into the tissues by electricity one or other component of a salt. In ionization treatment the ion with which we wish to produce an effect is actually introduced more effectually than by simply rubbing the drug on to the tissues, or by allowing a solution of it to remain in contact with them.

In salts such as perchloride of mercury, hydrochloride of cocaine, sulphate of quinine, sulphate of zinc, iodide of potash, it is one of the ions which furnishes the therapeutic action. The other ion is, from the point of treatment, not used. In the special treatment described in this book the therapeutic effect is produced by the zinc ion.

In certain chemical reactions a visible physical change accompanies the chemical one. Thus a cloud of silver chloride may be formed, or a coagulum of zinc albuminate. When an insoluble body is produced, such as silver chloride, or when zinc albuminate is formed in or on the tissues, the precipitate remains where it is formed. The precipitate is not carried away into the general circulation, and it does not immediately disappear from the surface on which it was produced. When a soluble compound results from the union of an introduced ion such as strychnine, morphine, or cocaine, with an ion already present in the tissues such as chlorine, the compound finds its way into the circulation, and general, in addition to strictly local, effects are caused.

Action at Electrodes.—It is in contact with the electrodes that the ions are converted into atoms, and it may be asked what happens to these.

One of several things may occur : (a) The atoms may fall down to the bottom of the vessel holding the solution as an insoluble precipitate ; or, (b) they may be deposited on the surface of the electrode and adhere to it, as in electroplating ; or, (c) they may react chemically either with the surrounding water or with the metal of the electrodes. The action which

occurs depends on the particular atom, and on the material of which the electrodes are made.

To take the case where the negative electrode is made of tin and is applied to the skin over a folded towel wrung out of salt solution. The sodium ions at the surface of the metal tend to be converted into atoms. These nascent atoms react with the water to form caustic soda (NaOH). This dissociates into Na and OH ions. The alkaline OH ions travel towards the positive electrode, and if the layer of towelling is not thick enough they would, during the course of a long treatment, reach the skin and cause a burn. After use the lint or the towel intervening between the skin and the

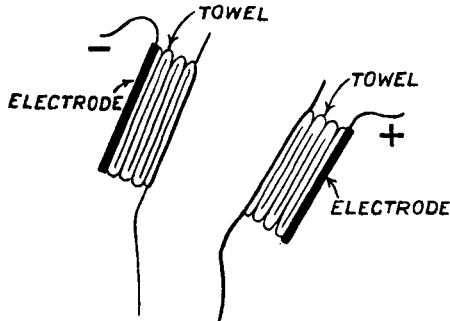

FIG. 6.

electrode should be well rinsed in water to remove all trace of alkali before being used again.

Again, take the case in which the positive electrode is a zinc wire dipping into a solution of zinc sulphate. The SO_4 ions at the surface of the electrode, tending to become 'an atomic group' (nascent SO_4), react with the zinc to form ZnSO_4 , which passes into solution, with the result that the zinc is gradually eaten away. If instead of dipping into a solution of zinc sulphate the wire dips into one of common salt, the nascent chlorine atoms react with the zinc to form zinc chloride, which passes into solution.

It is essential, when giving treatment to a patient, to be sure that we apply the correct electrode to introduce the ion

desired. Metals and substances such as the cocaine ion enter under the positive electrode; the halogens chlorine, iodine, bromine, groups such as NO_3 , SO_4 , and the salicyl ion, enter under the negative electrode.

To distinguish readily which is the positive electrode, a piece of blotting paper moistened with iodide of potash solution may be used. If the electrodes are made to touch the paper at a distance of half an inch from each other a brown mark will appear at the point where the positive electrode touches the damp paper.

Litmus paper may also be used if it is moistened with salt solution. A convenient method of testing is to take a towel wrung out of salt solution and place it on one electrode, and then with the other electrode touch litmus paper lying on the damp towel. If the metal electrode which actually touches the paper is the positive electrode, a *red* mark will be caused, if the negative a *blue* mark will appear.

From what has been said it will be plain that the effect which takes place in the treatment known as zinc ionization is primarily a chemical reaction—a replacement of an ion in the exudation or in the tissues by an ion introduced from outside which combines with the albumin in them; and secondarily a physical change—coagulation—owing to the insolubility of this new compound.

The agent by which the ions are transferred from the solution applied externally and made to penetrate and permeate the exudation on the tissues, and the tissues if desired, is the electric current.

CHAPTER IV.

EXPERIMENTS WITH ZINC IONS ACTING ON ALBUMIN AND BACTERIA.

Experiment 1.—The writer saw in Professor Leduc's lecture theatre an experiment thrown on the screen which helped him to understand some of the reasons why good results were obtained in the treatment of local septic affections by zinc ionization.

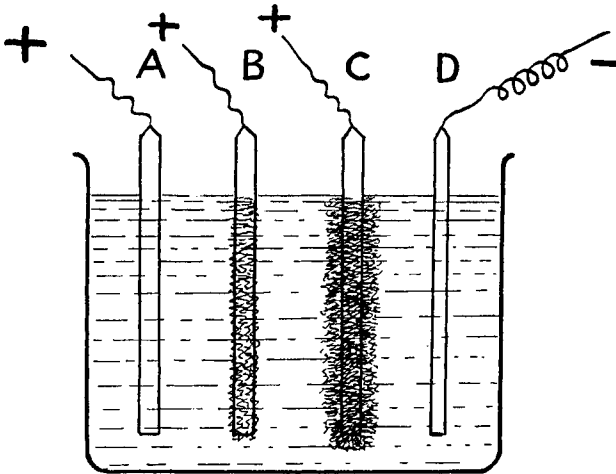

FIG. 7.—A, Iron; B, Copper; C, Zinc; D, Rod of any metal.

Into a glass cell containing serum, wires of iron, copper, and zinc were dipped, which were connected in turn to the positive pole of a source of electric supply (*Fig. 7*). Another wire which was connected to the negative pole was also dipped into the serum. When the current was turned on it was seen that from around the iron wire a dense fluid sank to the bottom of the cell. Around the copper wire a coagulation of the albumin took place, but the coagulum was

not firm, and on tapping the vessel it could be detached; whilst around the zinc wire a coagulum was also formed, but it was *firm* and adhered to the zinc, and if the zinc wire was lifted up the coagulum could be lifted up with it out of the fluid. This experiment has become classical.

Experiment 2.—This experiment can be carried out a little differently, as is shown in the diagram (*Fig. 8*).

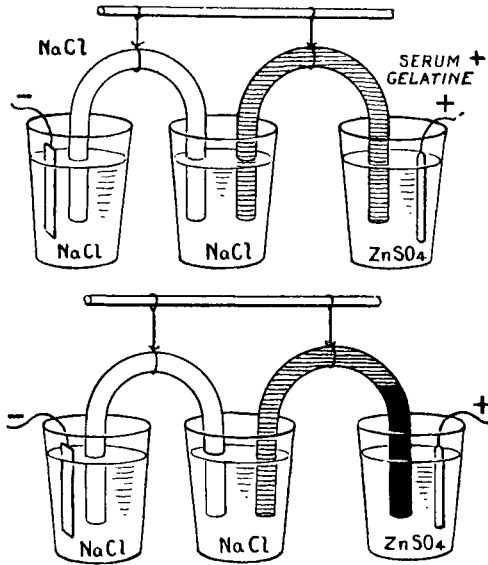

FIG. 8.

Blood serum is mixed with gelatin in order to facilitate the inversion of the tube and to confine the serum to the U-tube during the experiment. When the current flows it will be observed that a white layer appears at the lower end of the side next to the positive electrode. The zinc ions from the solution of zinc sulphate penetrate the tube, and their presence is shown by the serum adjacent to the zinc solution becoming white and opaque. The longer the current flows the further does the white opacity extend. Its advance is quite regular, and the delimitation between the portion

occupied by the white mass and the clear area in the tube is quite sharp. There is no 'shading off' visible to the naked eye. This strict delimitation between the area of coagulated

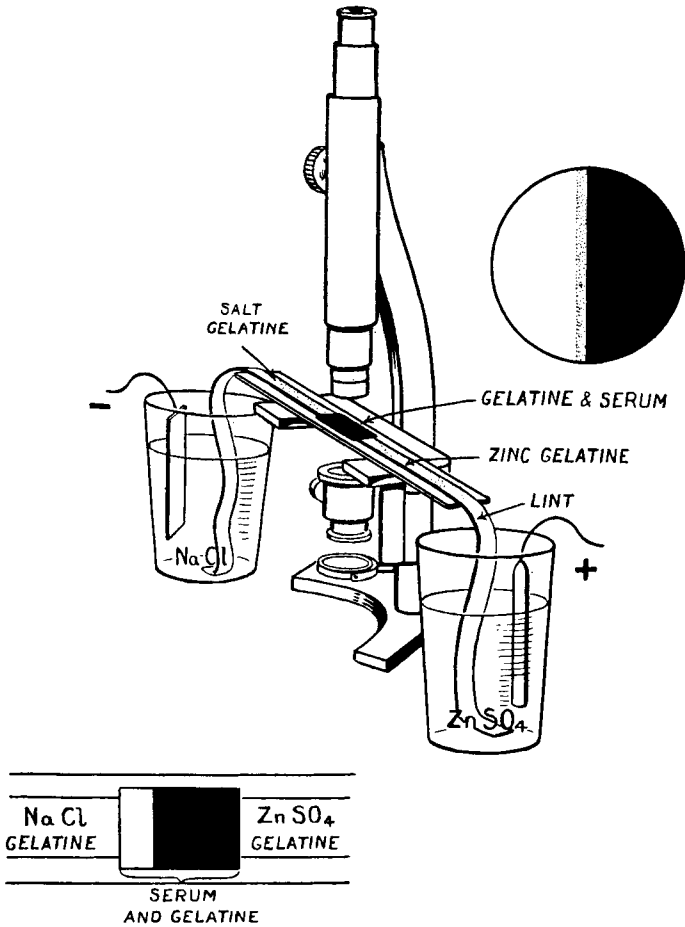

FIG. 9.

and non-coagulated serum explains the absence of inflammation *around* an area treated by zinc ionization. This absence of inflammation is in striking contrast with what happens when the actual cautery is used.

Experiment 3.—The occurrence and advance of coagulation can be observed under the microscope by arranging the experiment as shown in the accompanying sketch (*Fig. 9*). The coagulated area appears as a finely granular sheet. It is interesting to watch the steady advance, and anyone who does so will have more than a theoretical appreciation of the power of the electric current to make zinc ions penetrate fluids, or jellies, or tissues.

Experiment 4.—It is to be expected that jellies such as nutrient agar or gelatin used as culture mediums for bacteria will be changed in their suitability for this purpose by being

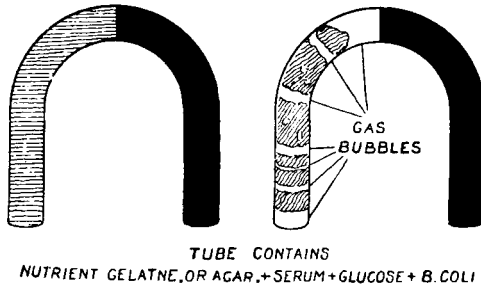

FIG. 10.

permeated with zinc. The following experiment is of interest in this connection (*Fig. 10*).

The U-tube is filled with nutrient gelatin or nutrient agar, with or without blood serum added, and containing some glucose, and heavily implanted with *B. coli*. When the zinc has penetrated half-way through the tube, as is shown by a white coagulum where serum is present, or as a cloudiness when agar or gelatin alone is used, the current is turned off and the tube is placed in the incubator. It is examined on the following day, and it will be seen that the extent occupied by the grey-white coagulum is unchanged, whereas the part into which the zinc has not penetrated is broken up by bubbles of gas, owing to the fermentation of the glucose by the *B. coli*. *The zinc ions have inhibited the activities of the B. coli.* If the tube is cut across in several places and small

pieces of the medium are removed and smeared over agar, it will be found that a growth will usually be obtained from the portion penetrated by the zinc, but the number of colonies is diminished, as compared with a sample taken from the portion of the tube into which the zinc has not penetrated.

If a similar experiment be carried out with copper ions, it will be found that for the greater part of the portion occupied by the copper ions there is complete sterilization. If the experiment be repeated, using mercury ions, no bactericidal effect is shown.

It is to be concluded that in the living body, owing to penetration and coagulation of the whole thickness of exudation and of the superficial layer of cells, the antiseptic effect of zinc ionization is more effective than when merely superficial coagulation of the exudation is caused by a zinc lotion. It is also more persistent, as there is no immediate dissipation of the antiseptic after it is introduced.

Conviction as to the efficacy of zinc ionization as a means of treating chronic local sepsis in the body is above all obtained in practice by observing the results which follow its application in cases in which the sole factor responsible for keeping up suppuration is sepsis in an accessible position. Our belief that this is a suitable method is more readily reached, however, if we consider the electrical, chemical, and bacteriological facts on which the treatment is based.

CHAPTER V.

VOLTS—OHMS—AMPÈRES.

It is easy to grasp the meaning of some of the terms used in regard to a current of electricity which one cannot see, if we compare it with a current of water.

When the vessel A is filled with water and the tap is opened, a stream of water rushes out owing to the pressure exerted by a column of water whose height is that of the vessel. When we attach another vessel, B, to the inlet of A, the stream rushes out twice as quickly since the pressure is doubled. If the tap, instead of being wide open, is only opened a quarter, the rate of flow is reduced to a quarter. The rate of flow is proportional to the pressure and inversely proportional to the resistance (*Fig. 11*).

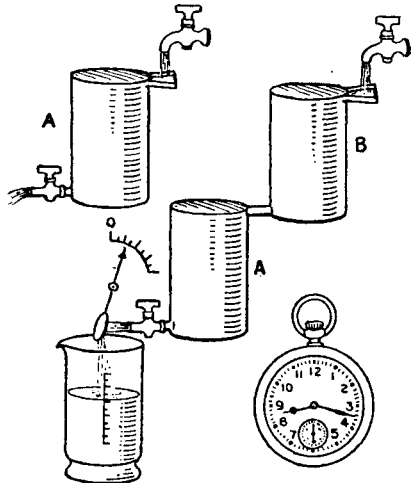

FIG. 11.

If we wish to measure the rate of flow by our ordinary standard units of quantity and time, we do so by placing a measure under the tap and allowing the water to flow for one minute and seeing how many ounces or pints of water there are in the measure; or, if we prefer, we measure the time it takes for a given quantity—e.g., a gallon—to flow. We can then say that for a certain pressure, and at a certain

size of opening of the tap (i.e., resistance), the rate of flow is so many gallons a minute.

By allowing the water to strike against a piece of wood pivoted on a support and working against a spring, the wood will be displaced and a pointer will be made to move. We can indicate the amount of movement by a graduated arc. Various rates of flow can be marked on the arc. In future, instead of measuring the rate of flow with a measure and a watch each time we open the tap, we can know what it is by looking at the markings on the arc. There is, however, no special word to specify, e.g., 5 oz. a minute. We have to use the words '5 oz. a minute'. By knowing the length of time that the stream flows at a certain rate, we can calculate the quantity of water which flows. Thus, if the water flows at the rate of 5 oz. a minute for half an hour we can say that 150 oz. have flowed out.

In the case of the electric current the galvanic cell corresponds to the vessel of water, and when we complete the circuit by closing a switch and moving the slide on the top of the resistance coil, which is equivalent to opening the tap, the electric pressure, or 'potential' as it is called, will cause electricity to flow along the wire joining the terminals. This potential will be doubled if we connect two cells together like the vessels of water, by joining the positive terminal of one to the negative of the second, and the rate of flow of the current will also be doubled. The rate of flow will be halved if we increase the resistance so that the total resistance of the whole circuit is twice what it was. Just as in the case of the water, the rate of flow or strength of the current is proportional to the potential, and inversely proportional to the resistance.

Rate of flow implies quantity and time. To specify these we make use of certain units as standards. The unit of time taken as the standard is one second, and the unit of quantity taken as the standard is that quantity of electricity which, flowing through an electrolytic cell containing a solution of nitrate of silver, will cause a deposit at the negative electrode of 0.001118 grm. of silver. This quantity of electricity is

called a *coulomb*. The unit rate of flow taken as the standard is when this quantity passes in a second. In practice this rate is measured by an instrument whose working depends on the action which an electric current exerts when it passes along a wire encircling a magnet. The magnet is deflected, and a strong current deflects it more than a weak one. The amount of deflection for different rates of flow can be marked on an arc placed behind or below a pointer attached to the magnet. Instead of marking $\frac{1}{2}$ coulomb a second, 1 coulomb a second, and so on, a special name is given to the *rate* taken as the standard unit—a coulomb a second. It is called an

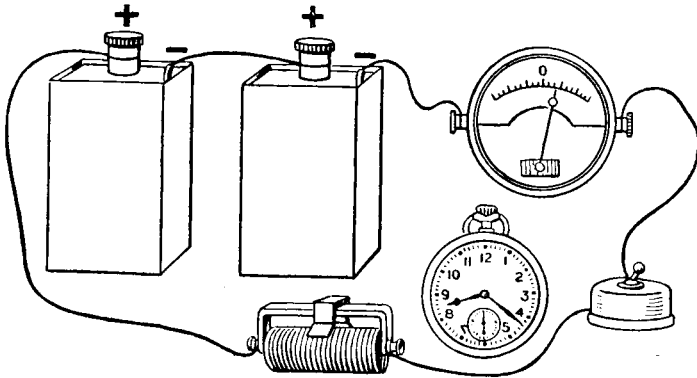

FIG. 12.

ampère. There are not many words to indicate special and definite rates. One thinks of 'knot' and 'horse power'. Usually a rate is expressed by specifying quantity and time; but in a few instances a special word has been coined, and in the case of the electric current 'ampère' has been chosen to indicate the rate selected as the standard unit. For medical treatment the instruments have been graduated to record a thousandth of an ampère, or a milliampère. As the instruments do not measure quantity but rate, it is necessary, if we want to know the quantity of current which passes in a given time, to state both the rate of flow and the time for which it flows. We do not usually work out the dose we

give our patients in units of quantity (i.e., coulombs) per unit area of surface.

In the case of the ear we assume that most ears are about the same size, and it has been found by experience that a quantity of current represented by a rate of 3 ma. for 10 minutes is a suitable dose for a case of chronic otorrhœa due to sepsis in the tympanum. If the area of sepsis is large, as happens after a radical mastoid operation, a suitable dose would be represented by 4 ma. for 20 to 30 minutes. In all cases that which matters is the quantity of zinc ions introduced, and this quantity is determined by the strength of the current and the length of time for which it is applied, i.e., the quantity of electricity which flows.

There are two other electrical units which are frequently mentioned—the unit of potential, and the unit of resistance.

The unit of potential is called a *volt*, and is approximately equal to the potential of a Daniell's cell. A single dry cell has a voltage of $1\frac{1}{2}$. A single accumulator cell has a voltage of 2. The electric mains which supply current to light our houses carry a current at a voltage of 200, 220, or 240 in most cases.

The unit of resistance is called an *ohm*, and is the resistance offered to the passage of a current by a column of mercury 1 mm. thick and 106 cm. long at a temperature of 0° C.

The units which have been mentioned bear a convenient numerical relation to each other; thus a potential of 1 volt causes a current to flow through a conductor whose resistance is 1 ohm at the rate of 1 coulomb in 1 second, and this rate of flow is 1 ampère.

CHAPTER VI.

THE SOURCES OF SUPPLY AND THE MEANS OF REGULATING THE STRENGTH OF THE ELECTRIC CURRENT—TECHNIQUE OF TREATMENT BY IONIZATION—LOCAL SUPPURATION TREATED BY ANTISEPTIC SOLUTIONS, BY THE CAUTERY, AND BY ZINC IONIZATION, CONTRASTED.

Sources of Supply of the Electrical Current, and its Regulation.—Suitable sources of supply are: (1) A battery composed of 18 dry cells (*Fig. 13*); (2) A 12-volt accumulator;

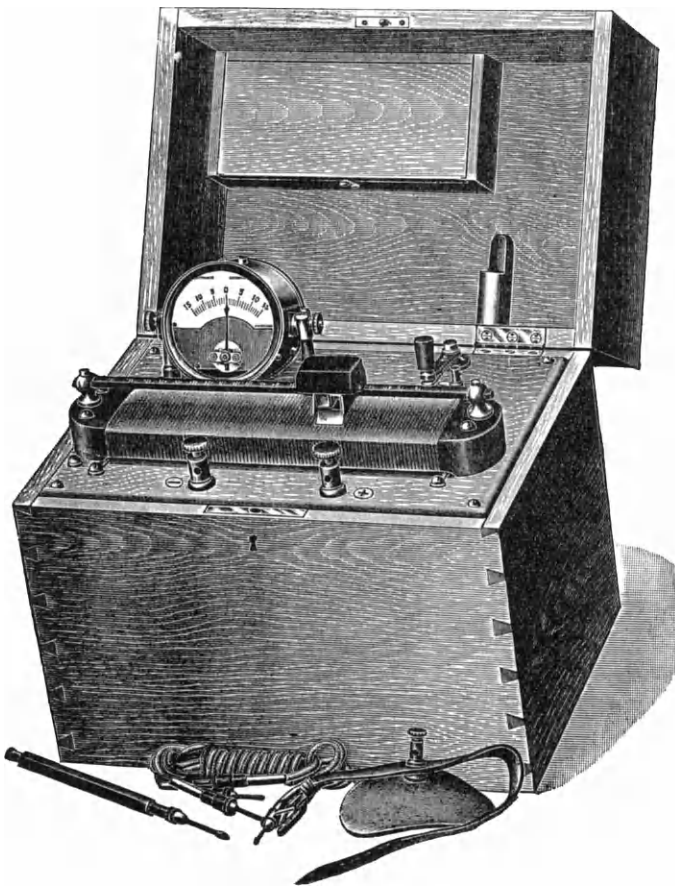

FIG. 13.

(3) The electric light and power mains when these furnish a continuous, not alternating, current. The easiest way to ascertain whether the current is continuous is to inquire at the power station if the current is D.C. or A.C. If it is D.C. it is directly suitable for ionization work. If it is A.C., that is, alternating, it is unsuitable.

The pressure or voltage at which the current is supplied

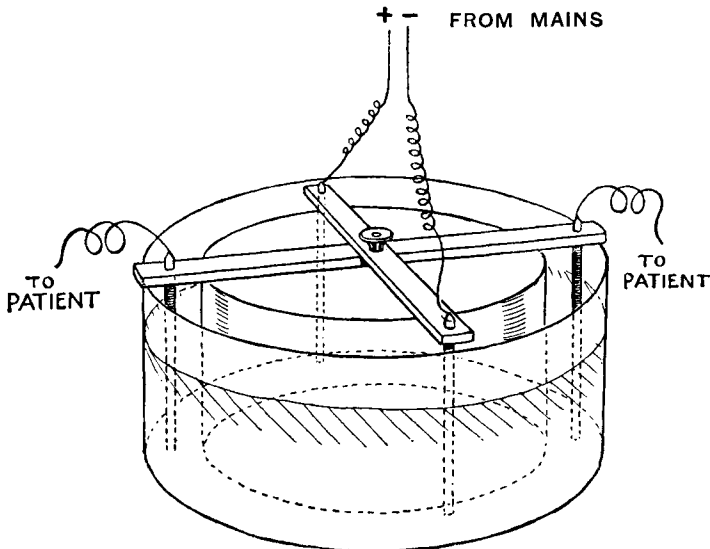

FIG. 14.—Professor Leduc's apparatus for regulating the amount of electric current passing through the patient.

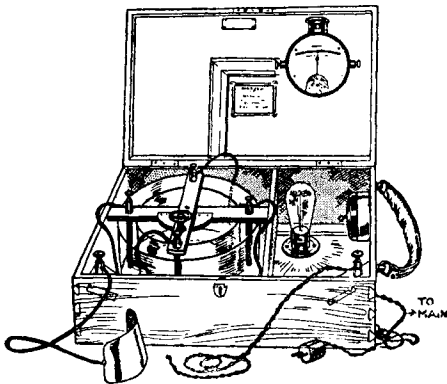

FIG. 15.—Leduc rheostat in box with milliampère-meter, switch, and lamp. The lamp: (1) Acting as a resistance, cuts down the current from the main; (2) Shows when the current is on; and (3) Necessitates greater movement of the crossbar on the rheostat to produce the same strength of current through the patient, and so finer regulation is permitted. When a strong current is required the lamp is replaced by a direct shorting plug.

must, however, be reduced to zero before it can be utilized. To effect this, and then gradually to increase it, a Leduc water rheostat can be used. The illustration (*Fig. 14*) shows its construction. Another variable rheostat which can be used when the current is taken from the mains is also illustrated (*Fig. 16*). It is known as a volt selector or shunt resistance, and works well.

One precaution which must be observed when the current from the mains is utilized is that the patient, and the doctor, or nurse, who applies the electrodes, must be insulated from the earth. They must not, for example, touch a water-pipe or a gas-pipe, or stand on a concrete or composition floor, while in contact with the apparatus. The floor should be of wood, or covered with an insulating material such as linoleum or cork lino.

General Technique of Treatment.—In giving ionization treatment to a case of chronic otorrhœa due to tympanic sepsis, the ear is cleansed and filled with a weak solution

of zinc sulphate,* into which a zinc wire dips. A piece of flex is soldered to the zinc wire and is attached to the positive terminal of the rheostat. Spring terminals are convenient. The zinc wire is prevented from touching the skin of the meatus by a vulcanite speculum, or a short tube made of glass or rubber. It is an advantage, especially in children,

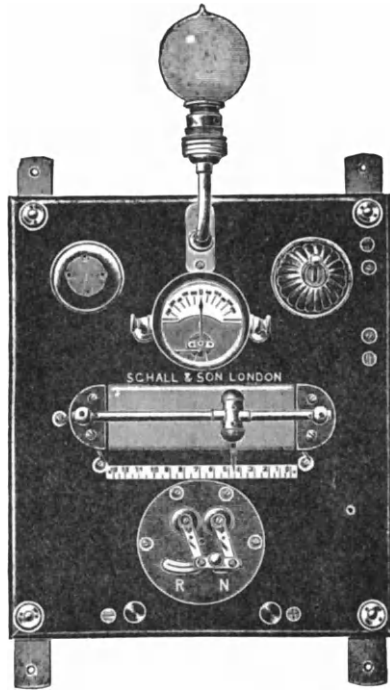

FIG. 16.—In this instrument and in the Leduc rheostat the patient does not form part of the main circuit.

* See page 31.

to place a wick of cotton-wool in the speculum, making it *project* from the lower end, in case the child is restless and by turning his head allows the solution to run out of the ear. The wick of cotton-wool prevents the current being then broken. If there is a raw place or a crack at the orifice of the meatus it should be smeared with vaseline.

To complete the circuit the indifferent electrode is applied to an area of skin, free from scratches or pimples, on the arm, or in the case of little children on the leg, over a thickly

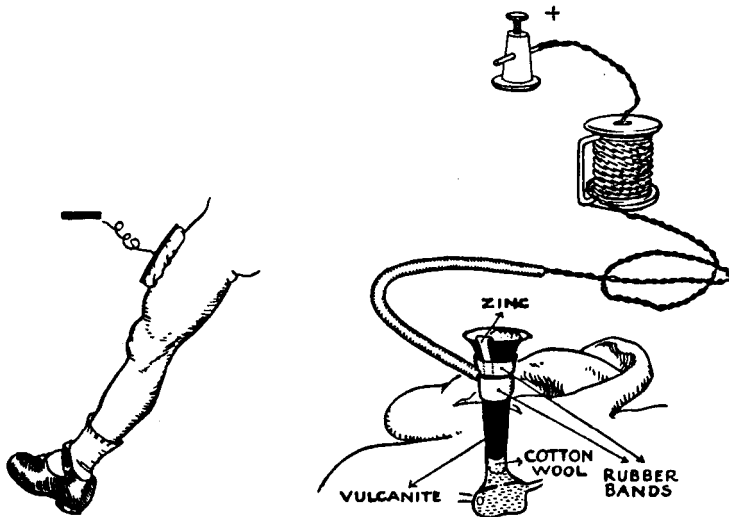

FIG. 17.

folded towel which has been wrung out of salt solution. On the towel a piece of flexible tin 5 in. by 4 in. is laid, to which has been soldered a length of rubber-covered flex. This is connected with the negative terminal of the rheostat. The tin and towel are held in position by a bandage. Care in applying this electrode is needed, as it is quite easy by ionization to cause an area of necrosis in the skin. If there is a raw pimple, or a recent scratch or abrasion, the resistance here is lowered; consequently the interchange of ions between the solution in the folded towel and the tiny piece of skin may be excessive, and may alter

the chemical constitution of the cells there so much that they die.

Wrinkles in the towel are to be avoided, for they lead to uneven pressure, and the current will enter more where the pressure is higher.

A screw connection of the flex to the tin or to the zinc wire should not be used, because corrosion is liable to take place and to interfere with the passage of the current. Then, when the screw is further tightened, an amount of current in excess of what was intended may flow. Moreover, a screw may work loose and lead to a make and break of the current, which causes discomfort.

It is necessary when considering the question of treatment of local suppuration by zinc ionization to take into account :—

1. The factor causing suppuration which we propose to act upon; the accessibility of the position where this factor is situated; and whether more factors than this are present which may require treatment before the particular factor with which zinc ionization deals is treated.

2. (a) The chemical reaction of zinc with albumin and the physical change resulting; the inhibitory action of zinc on bacterial activity. (b) The constitution of the chemical atom and of ions in general. (c) The nature, production, and properties of an electric current, and the means whereby it is applied and controlled. If one may be allowed to use an incomplete analogy, electric ionization is like a machine gun. The bullets represent the ions; the explosive, the electric force; the gun, the electrode, rheostat, switch, etc.

Hitherto, when we have made use of antiseptics to treat suppuration in the middle ear, we have been forced to be content to trust to the action which takes place at the point of contact of the antiseptic with the exudation or with the tissues. Diffusion and osmosis are of little use, for (except in the case of alcohol) we are not able to use the antiseptics in higher concentration than the salts in the tissues. Penetration does not take place readily. Moreover, in strong solution

the antiseptics would cause much pain and inflammatory reaction.

With ionization we can use a solution so weak that it is quite unirritating, yet we can make the ion we wish to use penetrate evenly to the depth we desire, and we can easily control the penetration by fixing the length of time, and the strength of current adopted in a treatment, in accordance with what we have found by experience is suitable in similar cases.

When zinc is introduced into cells its action is deadly to them, but the layer of adjacent cells is not irritated; when strong solutions of salts of zinc or other antiseptics are placed in contact with cells there is intense irritation and pain. In the former case the sphere of action is sharply delimited, in the latter it shades off gradually. Moreover, tissue into which zinc has been introduced is a poor culture medium for bacteria, whereas tissue which has been destroyed by the galvanocautery is liable to become extremely septic.

PART II.

**CONDITIONS IN THE EAR IN CHRONIC OTORRHOEA—
TECHNIQUE OF TREATMENT.**

CHAPTER VII.

SOLUTIONS—INSTRUMENTS FOR EXAMINATION.

Solutions.—

- | | |
|--|--|
| 1. Zinci Sulph. 5 grm.
Glycerin. 60 c.c.
Aq. 1000 c.c.
Dilute with an equal
quantity of warm water | Zinci Sulph. ʒj ʒij
Glycerin. ʒxvj
Aq. Chlor. ad ʒlxx
ʒj added to
ʒvij warm water |
| 2. Cocain. Hydrochlor. 5 grm.
Liq. Adrenalin. 5 c.c.
2 per cent Sol. Potass. Sulph. 25 c.c.
0·5 per cent Sol. Acid. Carbol. ad 100 c.c. | gr. lxxv
ʒiss
ʒvij
ʒiiiss |
| 3. Cocain. 1 grm.
Menthol. 1 grm.
Acid. Carbol. (Anhyd.) 1 grm.
Adrenalin. Hydrochlor. 1 mgrm. | (Bonain's
solution) |
| 4. Nitrate of Silver: (a) In solution ʒj ad ʒj distilled water;
(b) In powder | |
| 5. Acid. Carbol. Liquefact. ʒj | |
| 6. Sol. Acid. Picric. 2 per cent in 60 per cent Alcohol | |
| 7. Tinct. Iodi | |
| 8. Hydrarg. Oxid. Rubr. 0·15 grm.
Zinc. Oxid. 4·0 grm.
Vaselin. 20·0 grm. | (For the nose: astringent
and antiseptic) |
| 9. Æther. Pur. | |
| 10. Insulating Varnish: Celluloid dissolved in equal parts of
amyl acetate and acetone. A viscous liquid results,
and the viscosity can be regulated by the quantity
of solvent. The writer uses a solution of syrupy
consistence. A few drops of carbol fuchsin are added
to enable one to tell easily whether an instrument
has been varnished or not. | |

Instruments.—

1. Ear specula. Set of 4, fitting Peters' Siegle's pneumatic speculum. (A plane glass is easier to work with than a lens.)

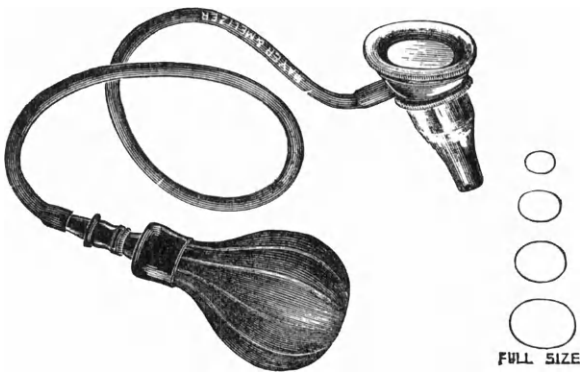
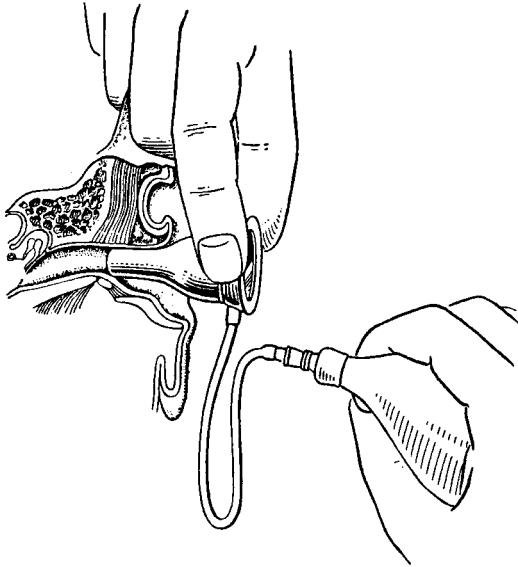

Figs. 18, 19.—Ear specula.

2. Forceps of various types (*Figs. 20, 21, 22*):—

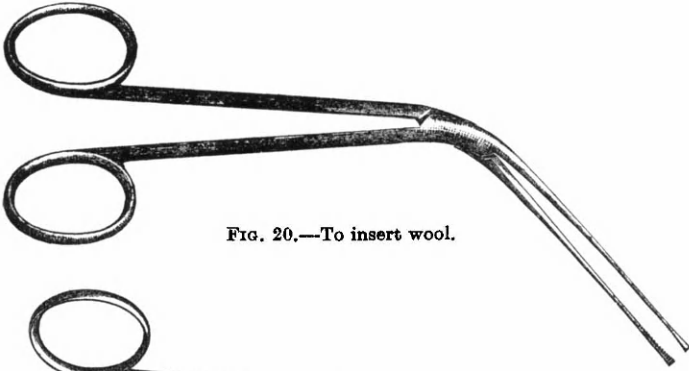

FIG. 20.—To insert wool.

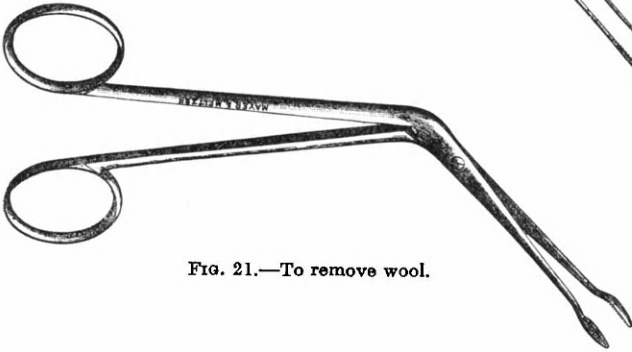

FIG. 21.—To remove wool.

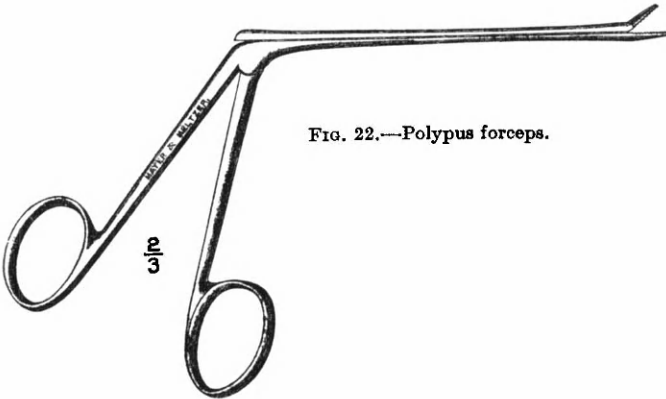

FIG. 22.—Polypus forceps.

3. Wool-holder (*Fig. 23*). Dr. Jobson Horne's is a good pattern.



FIG. 23.—Wool-holder.

CHRONIC OTORRHOEA

4. Bent probes (*Fig. 24*): (a) Steel, for cocaine (Bonain's solution), and for wool with nitrate of silver solution; (b) Silver probe, for fused AgNO_3 . This probe should be as thin as the steel one.

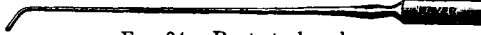

FIG. 24.—Bent steel probe.

5. Nasal speculum.
6. Tongue depressor (wooden strips convenient).
7. *Short-focus* head reflector (*not* a laryngeal reflector), to use with an electric bulb enclosed in a shield on a stand. Hasslinger's electric head lamp is excellent. An accumulator, or a resistance if the mains are used, is needed for it.
8. Syringe ($\frac{3}{4}$ iij size).
9. Attic cannula and bottle (see pages 43, 47).
10. Ionization apparatus: two sets.
11. Powder insufflator.
12. Ear electrodes (see pages 28, 45).

CHAPTER VIII.

ANATOMY—EXAMINATION OF THE EAR—TECHNIQUE OF CLEANSING THE EAR—CONCLUSIONS DRAWN FROM THE CONDITIONS OBSERVED—THE 'CAUSES OF CHRONICITY' IN CHRONIC OTORRHOEA: THEIR CLASSIFICATION AND THE TREATMENT APPLICABLE TO EACH—RESULTS OBTAINED IN EACH CLASS—THE SPHERE OF ZINC IONIZATION: ITS USE IN TREATMENT AND DIAGNOSIS—RESULTS.

ANATOMY.

A FEW anatomical illustrations are placed at the beginning of this chapter in order to make what follows more readily understood. For the use of *Figs. 25, 26, 27*, the author is indebted to the Oxford University Press. They are taken from Mr. Hunter Tod's *Diseases of the Ear*, revised and largely rewritten by Dr. Cathcart. The author wishes to express his indebtedness to the Oxford University Press and to Dr. Cathcart.

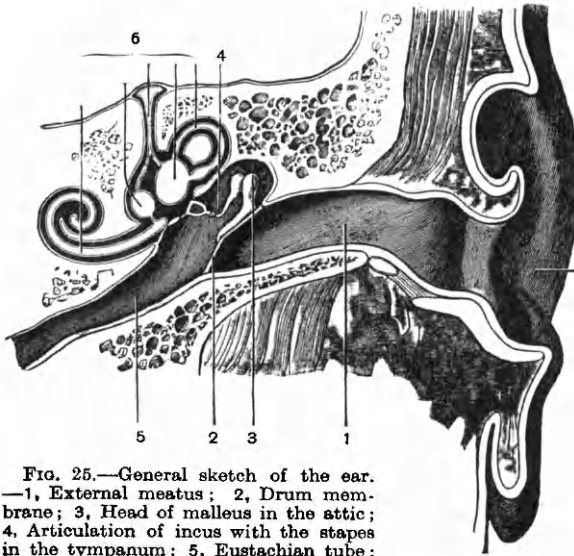

FIG. 25.—General sketch of the ear.
—1, External meatus; 2, Drum membrane; 3, Head of malleus in the attic; 4, Articulation of incus with the stapes in the tympanum; 5, Eustachian tube; 6, Structures in the internal ear.

EXAMINATION AND DIAGNOSIS.

Examination.—It is usually possible to decide from clinical signs whether a patient is suffering from *acute* or from *chronic* suppurative otitis media. In the former case the onset was recent, there is a *muco-purulent* discharge, and there are

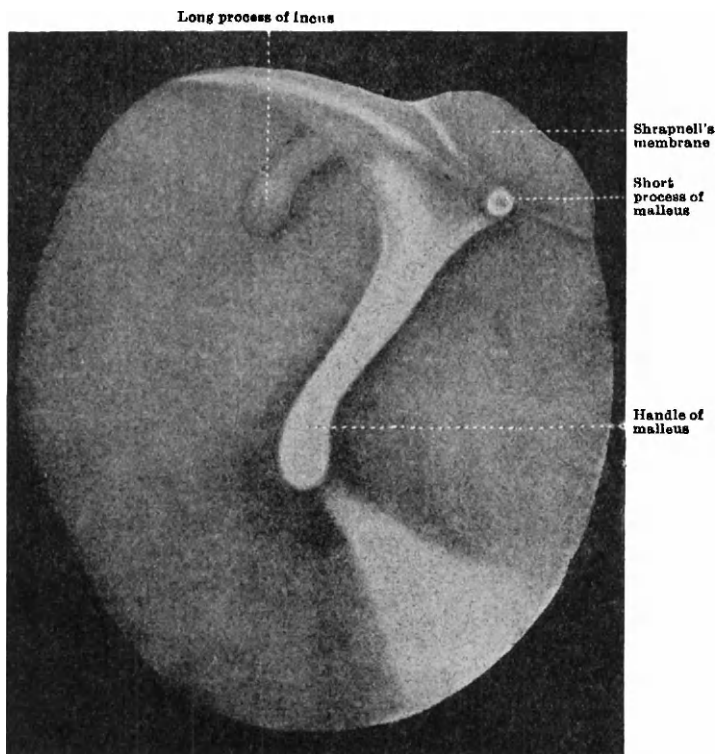

FIG. 26.—Right drumhead.

often signs of active inflammation. In the chronic case that one sees most frequently the otorrhœa is of some standing—of weeks' or months' duration; the signs of active inflammation have passed away, and the discharge is usually more purulent than mucoïd. One must not forget that a chronic condition may have an acute condition grafted on to it.

It is not as a rule necessary to make a microscopic examination to decide between the acute and chronic condition.

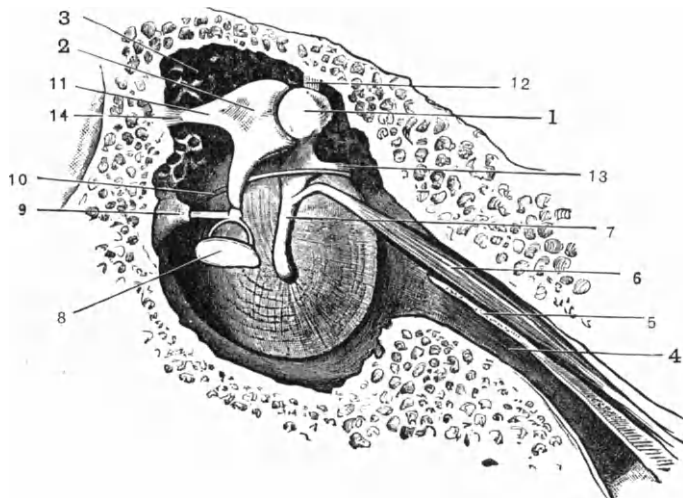

FIG. 27.—Left tympanic cavity. 1, Head of malleus; 2, Body of incus; 3, Attic or epitympanum, containing (1) and (2). The outer wall of the middle ear is viewed from the inside. Above, opposite the head of the malleus, it is formed by bone; opposite the neck of the malleus is Shrapnell's membrane. The drum membrane forms the outer wall of the tympanum proper. The outer wall of the lowest part—the hypotympanum—is formed by bone. 4, Eustachian tube.

5, Septum; 6, Tensor tympani muscle; 7, Handle of malleus; 8, Stapes; 9, Pyramid; 10, Chorda tympani nerve; 11, Short limb of incus; 12, 13, 14, Ligaments.

There is one condition, however, in which a microscopic examination of the discharge is of much help in arriving at a diagnosis. Occasionally it is difficult to distinguish between diffuse external otitis with moist desquamation, and middle-ear disease. In the former case the discharge consists almost entirely of squamous epithelial cells, while in the latter the polynuclears are the principal cells present.

It is often difficult to obtain an accurate history of the

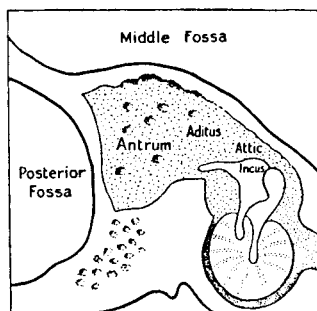

FIG. 28.—Diagram to show the relation of the antrum to the tympanum. The drum membrane of the left ear is viewed from the inner side.

events in connection with otorrhœa in a patient. The writer has usually to content himself with finding out how long the discharge has lasted. Still, if one has an intelligent patient, or relation, who can give the history, it is a decided advantage to know it.

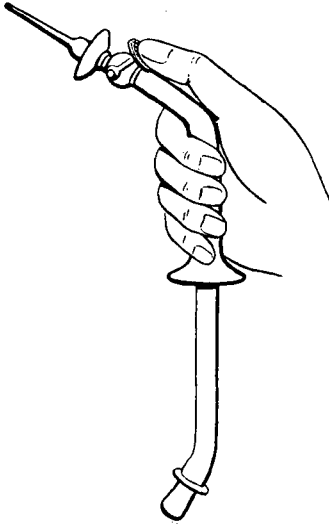

FIG. 29.—Ear nozzle for use with a douche can. Dr. Clarke uses a can which can be raised or lowered by a string passing over a pulley. The rubber tube is attached to a handle, and the nozzle has a flexible rubber ear-piece. Children prefer this apparatus to a syringe.

At the patient's first examination the amount of discharge is noted, whether it is clear, mucopurulent, or purulent; and whether foetid. Fœtor persisting after an ear has been syringed points to decomposing material in a recess which cannot be readily washed out, e.g., the attic or mastoid. Fœtor may be detected when examining the ear with the pneumatic speculum.

Having noted the amount and character of the discharge, the ear is next cleansed. This is usually done by syringing with warm water and then drying with a wick of cotton-wool. A glance will show whether the drum is really clean. If it is, a careful examination is made.

If it is not clean, a small pledget of cotton-wool dipped in a weak solution of cocaine and adrenalin is swabbed over the drum, or is inserted into the depths of the meatus and allowed to remain in contact with the membrane for a few minutes, or the middle ear if the membrane is absent or the perforation a large one. A fresh attempt to cleanse the ear is then usually successful. It may be syringed, or rubbed with a little wool wrapped round a wool-holder, or the pledget may be dipped in ether* and then

* For this use of ether the author is indebted to Dr. Peters.

rubbed over the remains of the membrane, special attention being paid to the upper part. To see accurately the condition of the drumhead, and middle ear if it is exposed, it is necessary that the ear should be quite clean. Every trace of discharge and desquamated epithelium should be removed. If ether is used to do this, the ear should be syringed immediately with a little *lukewarm* water to remove the ether. The writer asks the nurse to hold the syringe ready so that he can remove the ether at once. By this means severe smarting is avoided.

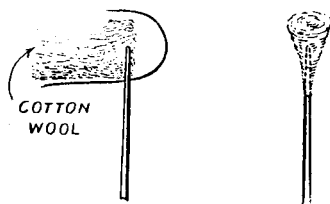

FIG. 30.—The late Dr. Fitzgerald, of Dublin, used to teach how to wrap cotton-wool on a holder so that it did not come off.

Next we note the condition of the orifice of the external meatus. Sometimes it is red and excoriated, and this means that the discharge is what Sir Almroth Wright calls 'corrupted'. The leucocytes have been extensively broken down and have set free their tryptic ferment which digests some of the epithelial covering of the skin. The skin is then more liable to be injured by irritants, such as a very septic discharge from the mastoid.

In the drum membrane one should seek to recognize the short process of the malleus. It is the point from which to take bearings. The drum membrane is inspected to see if there is a perforation. If one is seen, its position and size are noted, as well as the condition of the drumhead tissue, and of the mucous membrane and epithelium covering the inner wall of the tympanum, the presence and position of such things as granulations, or a polypus (and the place from which it springs if possible); whether the handle of the malleus is intact or is in part eaten away.

Special attention should be paid to Shrapnell's membrane (*Fig. 31*). Is there a perforation in it? (Ether is most useful in cleansing the surface of it.) It is not sufficient to say, "I do not see a perforation there". It should be, "I am sure there is, or is not, a perforation there". The

ear is then aspirated,* and one watches during the suction to see whether pus is drawn from some recess. The arrows in the diagram (*Fig. 32*) indicate the places at which pus or cheesy material is most likely to appear.

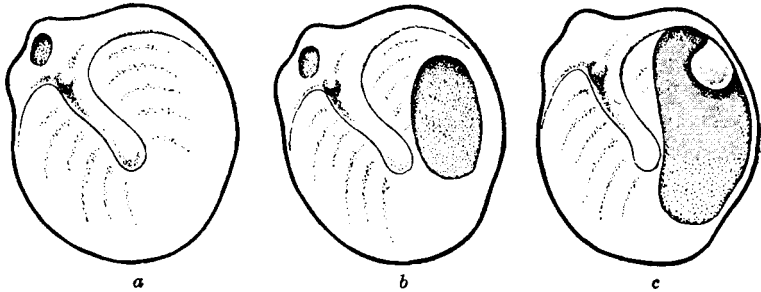

FIG. 31.—*a*, Perforation in Shrapnell's membrane; *b*, Perforation in Shrapnell's membrane and in posterior portion of drum; *c*, Pus appearing at upper posterior margin on suction with a Siegle's speculum.

The colour of the mucous membrane of the inner attic wall, which is sometimes visible, is white, compared with the red mucous membrane of the inner wall of the tympanum.

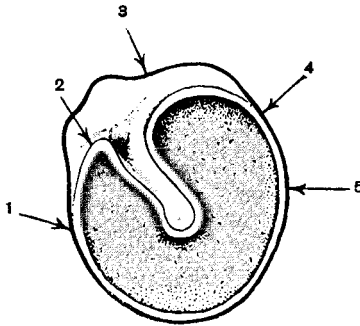

FIG. 32.—On suction, above the arrow marked 1, Mucopus from the Eustachian tube may appear; at 2, Pus or cheesy material from the anterior part of the attic; at 3, Pus or cheesy material from the posterior part of the attic or from the mastoid antrum; at 4, Pus or cheesy material from the mastoid antrum; at 5, Pus or cheesy material from a cell in the posterior wall.

The walls of the meatus, especially the upper and the posterior, are scrutinized to discover whether there is a granulation on them. This may indicate the opening of a sinus leading into a discharging cell in the mastoid. A bent probe introduced into the sinus can then be rotated slightly. The

* See page 32.

granulation may cover a small area of necrosis in the bony wall. If this is on the inner extremity of the roof it points to disease which has extended into the middle fossa of the skull. Situated elsewhere it may be the result of a severe furuncle, and when investigation is made with a bent probe a bare and rough surface of bone may be discovered.

If there is no perforation visible in the drum, confirmation of the drum being intact may be obtained by observing whether the drum is moved outwards and inwards when suction and compression are applied with a Siegle's pneumatic speculum. This does not occur when a perforation is present unless the perforation is excessively minute.

Long-standing discharge in a meatus in which there is no perforation in the outer wall of the attic or in the drum membrane, and no granulations, may be concluded to be due to diffuse external otitis. The discharge in diffuse external otitis is scanty and cheesy; in middle-ear suppuration it is more fluid. The treatment of external otitis is described later (p. 64).

The nose and throat and teeth are then examined, and the neck should be felt to ascertain whether there are any enlarged glands. Finally, look at the skin behind the ear to see if there is the scar of an incision, and note whether pressure over the seat of the antrum or on the tip of the mastoid process causes pain.

Diagnosis.—Having noted all the conditions, one proceeds to draw deductions. After one has examined a good many ears it will be found that cases of chronic otorrhœa fall into one or other of the following divisions, having regard to the factors keeping up the suppuration.

Cause of Chronicity.—

1. Accessible sepsis: e.g., tympanic sepsis.
2. Accessible sepsis with second factor in ear: e.g., polypus.
3. Accessible sepsis with inflammation in a neighbouring organ: e.g., rhinitis.
4. Inaccessible sepsis: (a) Accessible with difficulty: e.g., cell in mastoid opening directly into tympanum; (b) Totally inaccessible: chronic mastoiditis.

TREATMENT.

CASES OF SEPSIS ONLY, IN AN ACCESSIBLE POSITION.

There are a large number of cases in which the only factor responsible for keeping up the suppuration is *sepsis* in an accessible situation*. These are the cases in which there is septic fluid in the tympanum, but in which no polypi or granulations are to be seen, there is no perforation in Shrapnell's membrane, and, when suction is applied by means of a Siegle's pneumatic speculum, we do not see any discharge coming from the upper or the upper posterior part of the tympanum, or from an opening of a cell in the posterior wall, or from the region of the Eustachian tube.

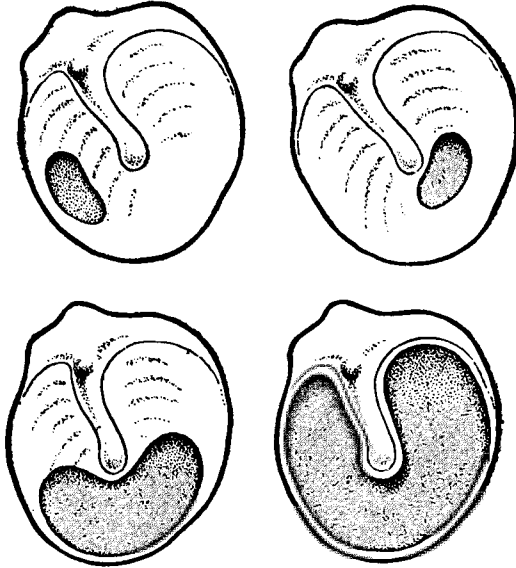

FIG. 33.—To show some types of perforation. Tympanic sepsis as the sole cause of chronicity is diagnosed by the *presence* of discharge in the tympanum and the *absence* of disease in the attic or mastoid, and by the absence of polypi, granulations, caries, rhinitis, and inflamed tonsils.

There is no rhinitis, no mucopurulent discharge on the posterior pharyngeal wall; the tonsils are not inflamed, the teeth

* 'Sepsis' is used throughout to indicate infection of the discharge as distinct from infection of the living tissues.

not markedly decayed, and there is no gingivitis. The only local factor keeping up the discharge is sepsis in the tympanum. As regards the patient's general condition, it is at least fair, and he is not suffering from a disease such as tuberculosis.

Tympanic sepsis, meaning by this infection of the discharge rather than infection of the living tissues is clearly a case for local antiseptic treatment such as zinc ionization.

To apply the zinc solution* *easily*, the perforation in the drum should be of such a size that the antiseptic fluid will enter by

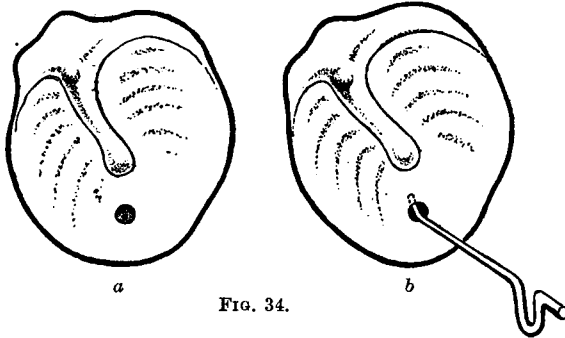

FIG. 34.

syringing the ear with it, or by pouring it into the meatus when the patient is lying down. If the perforation is very

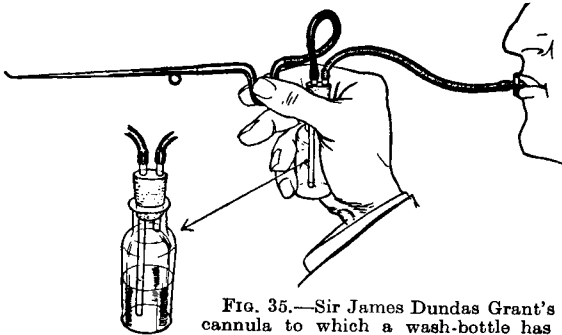

FIG. 35.—Sir James Dundas Grant's attic cannula to which a wash-bottle has been attached.

small (*Fig. 34 a*), the fluid should be introduced by a fine cannula (*Figs. 34 b, 35*), cocaine and adrenalin solution having

* See page 31.

been previously applied to shrink the mucous membrane and temporarily enlarge the perforation. Occasionally the writer injects with the cannula a few drops of this solution into the middle ear; or he partially fills the meatus with the solution and, pressing the tragus with the finger till the meatus is closed, presses directly inwards to force the fluid from the meatus into the middle ear. When the perforation is a tiny one at the summit of a nipple-like projection (*Fig. 36*), it is not possible to fill the tympanum with zinc solution. The

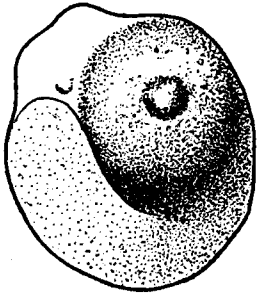

FIG. 36.

perforation in this case should be enlarged by nitrate of silver solution. The bent probe is dipped into a strong nitrate of silver solution and the point passed into the perforation. The solution adhering to the probe cauterizes the edges. Acid. carbol. liquefactum may be used in the same manner.

Having filled the tympanum and meatus with the zinc solution, gentle aspiration is practised with Siegle's

speculum to remove any bubbles of air which may be entangled in recesses.

Pressure with the finger on the tragus can also be used to induce the fluid to fill the upper part of the Eustachian tube. Dr. Norrie adopts this procedure as a matter of routine. When the meatus has been again filled, the positive electrode* is placed in the meatus, and the indifferent electrode attached to the negative terminal is placed on the arm or leg over a towel wrung out of salt solution; the current is gradually increased to 3 ma., and allowed to remain flowing for 10 minutes. If the patient complains of pain or discomfort, it is raised only to 2 ma. and kept flowing for 15 minutes. In very rare instances, 1 ma. is all the patient can bear, and it is then kept flowing for 30 minutes.

In cases where the perforation is very small, a fine electrode

* See pages 27-29.

may be pushed gently through the perforation in order to convey the current directly to the fluid in the middle ear and not via the fluid in the meatus. This electrode is shown later (*Fig. 49*, p. 59), but it is seldom needed in the treatment of cases of tympanic sepsis. At the conclusion of the ten minutes' treatment, the current is *slowly* reduced to zero. If care is not taken to do this very gradually, the patient will suffer from vertigo and vomiting. When the current is at zero, the electrodes are removed and the patient gets up. If one looks into the ear, one frequently sees the deeper part occupied by a white or grey-white coagulum. This is not to be disturbed.

Drs. Hollender and Cottle, of Chicago, have designed a good self-retaining electrode, the main features of which are shown in *Fig. 37*.

If the mucous membrane prior to treatment was smooth and the tissues did not show much swelling or congestion, nothing further need be done beyond telling the patient not to allow any water to enter his ear. He receives no drops or other local application to use at home. He is asked to come back to the clinic in a week's time.

If, however, the mucous membrane prior to ionization was finely granular or much congested, or there was a considerable amount of *muco-purulent* discharge, boracic acid is blown into the meatus after ionization in order to absorb and keep sterile any secretion coming from the ear while congestion is subsiding. Dr. F. P. M. Clarke, Assistant Aurist, Liverpool School Medical Service, paints the meatus in all cases with a 2 per cent solution of picric acid in 60 per cent alcohol after ionization of the middle ear, in order to keep the skin of the meatus as sterile as possible.

When the patient returns to the clinic in a week and is examined, it will frequently be found that his ear is quite

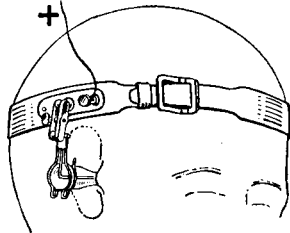

FIG. 37.—Electrode devised by Drs. Hollender and Cottle, of Chicago. It can be recommended.

clean and absolutely dry. In other cases a very slight discharge may be present without signs of inflammation. In these cases the slight amount of discharge is removed either by syringing or by a pledget of cotton-wool on a probe, and some boracic powder insufflated. When he returns the following week the ear will probably be dry.

The presence of discharge in the tympanum has a tendency to damp the hearing power, and it is to be expected that when the discharge ceases the hearing will be improved.

There are other cases in which little improvement has followed the treatment at the first visit. In these cases the ear is carefully re-examined to ascertain if the diagnosis was correct.

It will often be found that the general inflammation of the tympanum has subsided and that there is now localized evidence of disease adjacent to the tympanum, e.g., in the mastoid antrum or attic. Discharge may be readily aspirated now, and be seen as it appears at the upper part of the tympanum. Or a small polypus may be seen, or a granulation may be visible peeping out in front of the short process, or behind and above the handle of the malleus in the region of the long process of the incus.

In such a case the diagnosis had not been correctly made at the first examination although care had been taken to do so: the general inflammation had masked the condition. When the *generalized* inflammatory swelling had subsided, the *localized* evidence became recognizable.

Why was not the discharge coming from the attic or mastoid seen at the first examination? Because congestion caused by the aspiration, added to the swelling and con-

NOTE.—In cases with a considerable amount of mucoid discharge, treatment by boracic powder alone is sometimes adopted with a satisfactory result. It is necessary to aspirate repeatedly so as to empty the middle ear of mucus, and possibly permit the mastoid antrum to empty itself, before blowing in the powder. (See also page 58.)

When the discharge is clear and serous, boracic powder is sufficient without ionization, in the writer's experience. If this discharge is in large measure removed, and any further which comes away absorbed with the powder, it seems that the irritation vanishes and the discharge ceases.

gestion already present, closed the chink through which it should come.

The writer has been repeatedly struck with the value of zinc ionization as an aid to diagnosis. The disappearance of the inflammation over the greater part of the tympanum where irritation existed is due, he believes, to the antiseptic barrier formed by the zinc as it enters and coagulates the superficial cells, thus forming a layer which protects the subjacent cells and tissues from irritation.

Occasionally in other cases in which the diagnosis is correct and in which cessation of discharge has not followed, the cause of the failure is due to defective technique. Dr. Jobson is an advocate of washing out the tympanum in every case with an attic cannula, and says, "Intratympanic irrigation should always be done as a preliminary to ionization. By this means pus and débris can be washed out and the middle ear filled with the zinc solution at the same time. The irrigation can easily be done with a suitable apparatus (*Fig. 38*). This consists of a fine

cannula, suitably shaped so that the fingers introducing it are out of the line of vision, connected by rubber tubing with a 6-oz. wide-mouthed bottle, which in turn is connected with a rubber bellows. A clip on the tubing half an inch from

the cannula serves as a convenient handle and also controls the flow of the fluid. By squeezing the bellows a few times sufficient pressure is stored up to expel the fluid through the cannula. The object of the bellows is to allow the operator to have both hands free, the left for holding the speculum through which he introduces the cannula with his right hand.

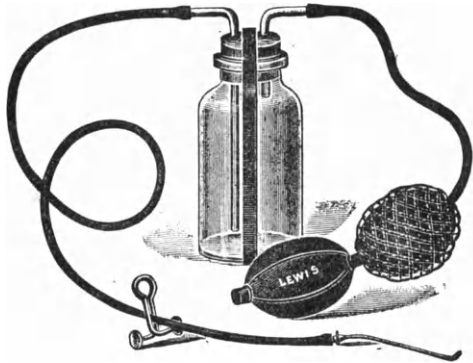

FIG. 38.—Apparatus for intratympanic irrigation.

It should be remembered that the cannula is a pointed instrument, also that the patient may jerk his head when the fluid is allowed to flow. By holding the cannula by the clip on the rubber tube a flexible connection is interposed and prevents any possibility of accident, even if the patient should move his head. Attention should be paid to the temperature of the fluid. If too hot or too cold it will induce vertigo. Before stopping the flow of the fluid get the patient to incline his head to the opposite side, and with the head in this position let him lie on the couch, where the ionizing process is then carried out."* The writer thought this was a counsel of perfection, but the value of the procedure was shown to him by an experience he had with a case of chronic otorrhœa. He considered it to be clearly a case due to tympanic sepsis only. It did not recover after two ionizations. He then washed out the tympanum with a cannula and dislodged a large clear blob of mucus from the region of the Eustachian tube. The ionization was then repeated and the discharge ceased at once.

The results obtained in these cases of tympanic sepsis are so favourable and so rapidly obtained that one is tempted to say that they are to be expected consistently.

The writer in a series of cases of chronic otorrhœa considered that 251† were due to tympanic sepsis. The results are given in *Table I*. In 234 the result was known; in 17 it was not.

Table I.—ANALYSIS OF IONIZATION TREATMENT OF TYMPANIC SEPSIS CASES.

A. LOST SIGHT OF.	
No. of Cases	No. of Ionization Treatments
8	1 visit, 1 ionization
3	2 visits, 1 "
3	3 " 1 "
1	3 " 2 ionizations
1	4 " 2 "
1	4 " 3 "
—	
17	

* *Electric Ionization, 2nd edition*, pp. 106, 107. † See page 67.

RESULTS

49

Table I—continued.

B. CURED.

No. of Cases	No. of Ionization Treatments	No. of Visits till Discharge Ceased
143	1	1
41	1	2
7	1	3
4	1	4
1	1	6
1	1	8
9	2	2
10	2	3
8	2	4
4	2	5
1	2	6
2	3	3
1	3	4
1	4	9
1	4	7
234		

It may be advisable to state in tabular form the position which we have reached so far.

In *acute suppuration* of the middle ear there is an infection of the tissues. Usually only one variety of micro-organism is present in the discharge.

Assist the patient by conserving his energy. Rest and warmth are indicated. If recovery slow, vaccines help. Locally, at first encourage the flow of serum by glycerin drops, and later, as the inflammation subsides, absorb the discharge by powders. There is no objection at this stage to zinc ionization, but it is not usually necessary. In cases of mastoid inflammation, operation is likely to be needed.

In *chronic suppuration* of the middle ear there is an infection of the discharge by many varieties of micro-organisms. The tissues are irritated by contact with this fluid.

Abolish the irritation by: (a) Absorption of the fluid by boracic powder when the amount of discharge is slight; (b) In more severe cases by the formation of an antiseptic barrier between the tissues and the outside world by means of zinc ionization.

The above treatments are reasonable where the area of sepsis is accessible, and when no other factor exists (or has been already removed) besides sepsis, to keep up the irritation.

Rest is given to the tissues, and they quickly recover.

Acute exacerbation occurring in cases of chronic suppuration.

The line of treatment to follow is that of the acute inflammation, and when this has subsided to deal with the chronic condition.

Cases of tuberculosis are not included under the above headings. They require general constitutional as well as local treatment. The general treatment is designed to assist the body to deal with the bacteria in the tissues, and the local to minimize the irritation due to added sepsis.

Cases of otorrhœa furnish material to teach us what are the factors which cause and maintain suppuration, and also the efficacy of our means of treating them. Especially have we an opportunity afforded us of forming an opinion as to the value of antiseptics. We learn from observing cases of acute suppurative otitis media that as a general rule the body is capable of dealing with bacteria which invade the tissues. From observing cases of chronic suppurative otitis media we learn that the body is not so capable of dealing with bacteria growing in exudation on the surface of cavities lined by mucous membrane or granulations.

Many antiseptics which are used to kill bacteria in water do so in a few minutes. They are admittedly efficient in such circumstances. Again, the surface of the skin can be rendered sufficiently sterile for practical purposes by painting it with tinct. iodi and other substances. The writer knows of no method generally applicable, except zinc (or copper) ionization, which leads to cessation of suppuration and disappearance of bacteria in an infected area, such as the middle ear or an abscess cavity, by a single and short application.

When we remember that the walls of a septic cavity are living tissues we realize that the strength at which we can use an antiseptic solution is limited. If we use preparations sufficiently strong to produce sterilization they cause necrosis of the tissue cells in closest contact with them, and intense irritation of those farther away. The albumin of the exudation is coagulated by those antiseptics which we can use with safety, and this coagulation limits penetration by diffusion.

Consider, on the other hand, that the solution of zinc used

in ionization is so weak that it may be used as an eye lotion, and yet the ions of the zinc in it can readily be made to penetrate the exudation, and to enter and coagulate the superficial cells (and deep ones if desired) of the mucous membrane.

If the reader will look at the diagram (*Fig. 8*) illustrating the experiment described on p. 17, he will see that the zinc permeates the serum, which becomes coagulated, the coagulum extending regularly from the extremity of the tube. He will also notice the sharp delimitation between the coagulated and the uncoagulated part. The writer believes that this explains the almost complete absence of inflammatory reaction which follows treatment of cases of tympanic sepsis with a moderate dose. If the dose is excessive and a layer of mucous membrane is destroyed, there is hyperæmia. When the dose is moderate and does not exceed that which has been found empirically to be suitable, one of the things which strikes one most forcibly, on looking into the ear a day or so after treatment, is the reduction of inflammation. The remains of the drumhead appear thin, and the mucous membrane of the tympanum has lost its swollen and congested appearance.

The zinc ions, although the exudation is coagulated, penetrate it, since the serum contains salts in addition to albumin. Zinc coagulates albumin but forms a soluble compound with chlorine. This soluble compound, which dissociates, forms a path for fresh zinc ions to enter and penetrate farther.

It is difficult to penetrate with silver, for silver albuminate is insoluble, and so is silver chloride.

It may be mentioned that duration of discharge *per se* does not prejudice treatment by zinc ionization; nor does the age of the patient. Zinc ionization is as successful in cases of accessible sepsis in adults as in children.

When we consider each case of chronic suppurative otitis media we realize that in every case the basic factor is sepsis; that in some cases the septic fluid occupies an accessible position, while in others, a part of the space occupied by the

fluid is difficult of access or is totally inaccessible. Whilst in many cases sepsis alone is the factor responsible for keeping up the suppuration, in other cases there are one or more additional factors such as a polypus, granulations, caries or cholesteatoma, rhinitis, inflamed tonsils.

The results obtained by zinc ionization in tympanic sepsis give us a clue how to proceed to deal with these other cases. We try: (1) To gain access to positions difficult of access by using special instruments; (2) To convert inaccessible positions into accessible ones by operation, and then use ionization; (3) To reduce multiple factors to the single factor, sepsis, and then treat this by ionization.

**CASES OF SEPSIS WITH ADDITIONAL FACTORS IN THE EAR
OR IN AN ADJACENT ORGAN.**

If there are factors in the ear additional to sepsis, it is advisable to remove them before attempting to deal directly with the sepsis. The additional factors most frequently met with are granulations, polypus, caries, cholesteatoma.

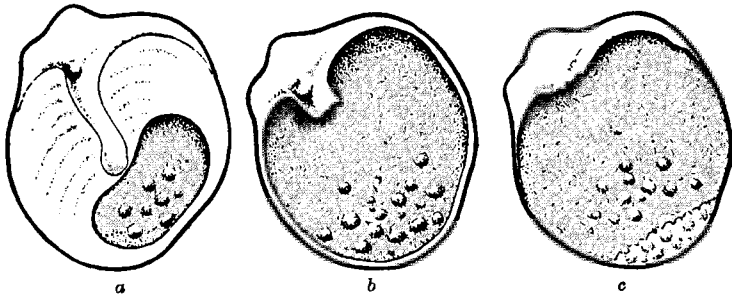

FIG. 39.—Types of granulations.

Granulations.—If the granulations are very small (*Fig. 39, a*) they may usually be neglected so far as treatment directed to them particularly is concerned. With the abolition of sepsis they disappear. If of somewhat larger size (*b*) they may be touched with a strong solution of nitrate of silver, or with solid nitrate of silver fused on the end of a probe. It is possible to localize the application and action by this means.

Occasionally one sees a granulation which it is difficult to touch without touching adjacent mucous membrane or the inner wall of the middle ear. The writer has applied a little vaseline to the part he was liable to touch but wished to avoid. If the granulations are large and polypoid (*c*), he finds the best method is to electrolyse them with the instrument used for treating polypi. The granulation tissue at the floor in *c* can be treated by this method.

Polypus.—When the polypus has a thin stalk it frequently comes away when the ear is syringed in order to remove discharge. In most of these cases it will be found that the polypus comes through a perforation in Shrapnell's membrane (*Fig. 40*). When a polypus is small and soft and is easily gripped by a pair of polypus forceps, the author frequently removes it by avulsion. Slight bleeding occurs, and to avoid septic complications he at once syringes the ear with zinc solution and ionizes it in order to seal the raw surface of the base or stalk of the polypus.

When the polypus is of moderate size he prefers to treat it by electrolysis. A little Bonain's solution is rubbed on the polypus, and on the wall of the meatus if in contact with it, and two zinc



FIG. 40.—Polypus showing through a perforation in Shrapnell's membrane.

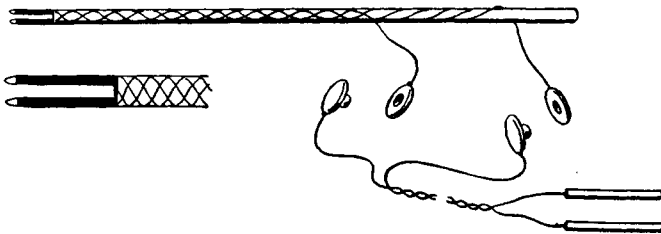

FIG. 41.—The author's instrument for treatment by electrolysis.

needles are pushed into the substance of the polypus (*Figs. 41, 42*). The more closely the needles approach the base of

the polypus the more successful the treatment will be. The current is turned on until it reaches 1 to 4 ma., and is allowed to flow for two or three minutes. The needles are then removed, sometimes bringing the polypus with them. At other

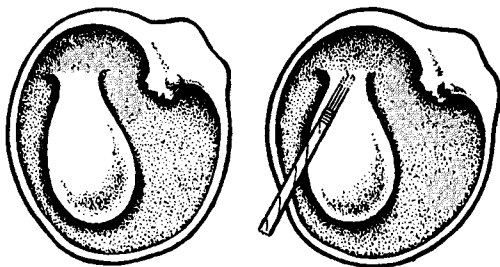

FIG. 42.—Removal of a polypus by electrolysis.

times it is seen that the projecting part of the polypus no longer bleeds. At the next visit no trace of one may be seen.

In other cases the electrolysis may have to be repeated several times until the nutrient vessel is reached. The electrolysis acts by coagulation. Zinc ions coming off the needle attached to the positive pole of the battery coagulate the tissues adjacent to it.

Care should be taken to varnish the projecting parts of the needle, and to remove the varnish from the tips only (*Fig. 41*).

Some polypi project into the tympanum from the aditus or an adjacent area. It is not possible to reach the base with zinc needles, and the writer removes them by avulsion (*Fig. 44*).

Occasionally one sees a small polypus in a very inaccessible place. It may be in front of the

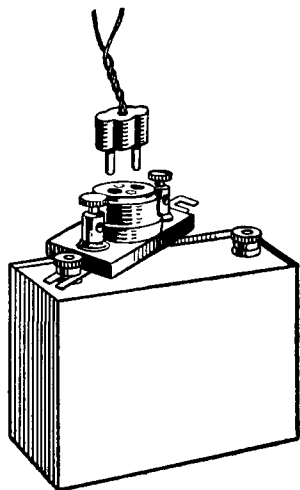

FIG. 43.—Convenient attachment devised by Dr. Clarke. The wires from the electrolysis needles can end in a plug or be attached to terminals. In the case of large polypi it is not necessary to use a rheostat.

short process. If one of the gelatin-covered wires* is placed in contact with it and the current turned on, the zinc ions from the gelatin may coagulate some of the polypus and

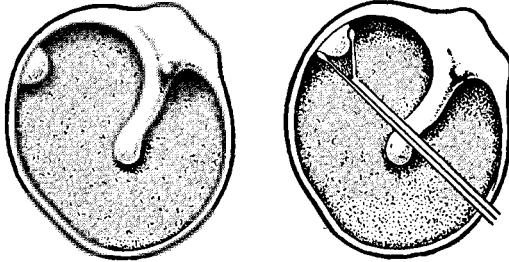

FIG. 44.—Removal of a polypus by avulsion.

'glue' it to the instrument, so that when the latter is removed the polypus comes with it. For this to happen the polypus must be small (*Fig. 45*).

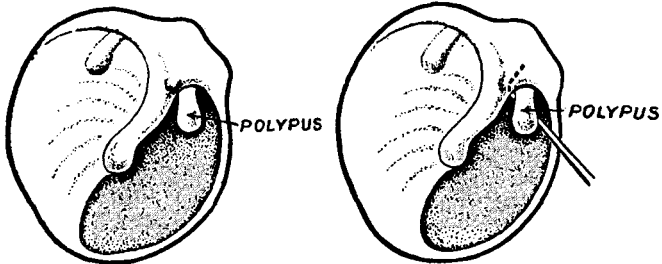

FIG. 45.—Removal of a small polypus by coagulation with zinc ions.

After a polypus has been removed from the tympanum it often happens that the ear ceases to discharge. Still, the writer makes a practice of bringing cases of polypus to the clinic at intervals to see if they have remained well, and, if not, to treat the condition found on re-examination.

Cases of polypi coming through Shrapnell's membrane or presenting at the upper posterior margin of the tympanum do not as a rule recover quickly. The diseased part from which the polypus springs is often difficult of access, and

*See page 59.

it may be necessary to enlarge the perforation in Shrapnell's membrane or to destroy a portion of the upper posterior part of the drumhead in order to make the area more accessible, and less of a box with a chink-like opening (*Figs. 50, 51, pp. 60, 61*).

Caries.—With regard to caries of the handle of the malleus (*Fig. 46*), for example, the author treats the ear by ionization

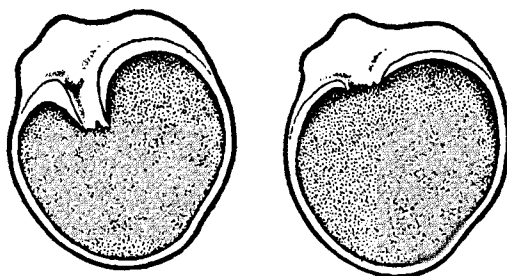

FIG. 46.

and then blows boracic powder into the tympanum once a fortnight to prevent it from becoming reinfected while the bone is recovering.

Cholesteatoma.—With regard to cholesteatomatous masses (*Fig. 47*), whether in the tympanum or adjacent to it, the

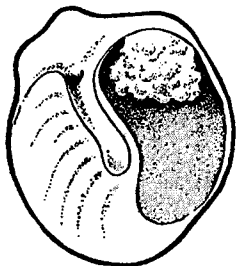

FIG. 47.

writer considers that one essential in treatment is to sterilize the area in which the septic material is present. It is generally believed that the cheesy material arises from a replacement of the normal epithelium by squamous epithelium growing round the edge of the perforation. The writer thinks that probably, in addition to this growth, the presence of sepsis is necessary for the production of cholesteatomatous

masses. In most cases the area covered by the cholesteatoma is inaccessible and an operation in hospital is needed.

Sepsis in Neighbouring Organs.—When in addition to sepsis, etc., in the ear there is inflammation in a neighbouring

organ, it is necessary to pay attention to that organ, e.g., *the nose*. Retention of secretion behind a deflection of the septum is very prejudicial to the recovery of a discharging ear. Suppuration in an *accessory sinus* of the nose likewise requires treatment, and so does the presence of a *foreign body* in the nose.

In *catarrhal inflammation of the nose or nasopharynx*, mucus can sometimes be seen at the tympanic opening of the Eustachian tube, or may appear on aspiration. In such a condition politzerization should be done before ionizing the tympanum.

Catarrhal rhinitis is frequently kept up by slight nasal obstruction. When this is due to engorgement of the inferior turbinals much benefit results from adopting the treatment devised by Dr. Gautier, of Paris, which he calls diastolisation.* Dr. Wells introduced it into the school medical service of the London County Council, and it has been extensively practised by Dr. Clarke in Liverpool. Nasal respiration is made possible. It is no longer necessary for the child to breathe through his mouth. To assist in overcoming this habit, the writer uses

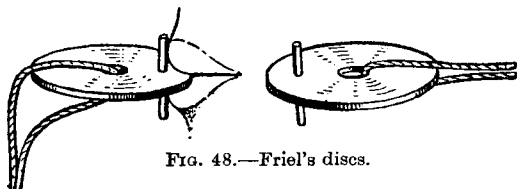

FIG. 48.—Friel's discs.

the discs (*Fig. 48*) devised by Mr. Sheldon Friel, M.Dent.Sc., Sc.D.

Definitely inflamed *tonsils* require removal. *Large* masses of *adenoids* blocking up the nasopharynx, whether there is inflammation or not, should be removed.

The writer does not consider that *hypertrophy of the tonsils* apart from inflammation prejudices the treatment of sepsis in the tympanum by zinc ionization. He treats the ear according to the method described and finds it recovers readily, with

**La Presse médicale*, 1924, p. 139.

no special tendency to recurrence of the discharge. In his experience it is the sepsis in the ear which is responsible for the continuance of the discharge. All are agreed that the chronic ear condition was preceded by an acute condition, and that the latter followed an infection of the throat. The acute inflammation of the ear and the throat having disappeared, another disease, explained as 'infection of discharge in the ear' by many varieties of micro-organisms, has supervened. The writer does not object to the removal of tonsils based on other indications of their effects, but is of opinion that in a large number of cases of chronic otorrhœa the presence of discharge from the ear is not a reason for their removal.

When the *teeth* are extensively decayed, or when there is gingivitis or pyorrhœa, dental treatment is required.

CASES OF INACCESSIBLE SEPSIS.

Hitherto the conditions in the ear have been described mainly under the broad heading of sepsis in an accessible position. Unfortunately in a good many cases of chronic otorrhœa the pus occupies a situation which is either only accessible to treatment from outside with difficulty, or not accessible at all. The latter cases* may be dismissed with the statement that, if this has proved to be so, operation is required: almost always a mastoid one.

When the septic area is accessible but with difficulty, special instruments are required (*a*) to cleanse the area, (*b*) to fill the cavity with zinc solution, (*c*) to distribute the electric current to the walls.

Every now and again one meets a case in which a suppurating cell in the posterior wall of the tympanum discharges into the middle ear. After the ear has been cleansed, pus is seen on aspiration. This may be discovered subsequent to ionization carried out a week previously. It is necessary to wash out

* Where the discharge is mucoid, the tympanum should be ionized in order to reduce swelling and favour escape of fluid from the antrum. A little boracic powder should be insufflated. A good number of such cases recover without operation.

this cell (*Fig. 49a*). A little cocaine and adrenalin solution is applied to the ear, and after a few minutes the cell is washed out with an attic cannula, using water or a little ether followed by water. Sir J. Dundas Grant's attic cannula (*Fig. 35*, p. 43) is convenient when attached to a small bottle of water.

When the cell has been cleansed it is filled by the cannula with the zinc solution. Before attempting this it is often useful to place the patient in a position in which the cell will retain the fluid. (An electric head-lamp is an assistance here.) The fluid which overflows must be removed by cotton-wool,

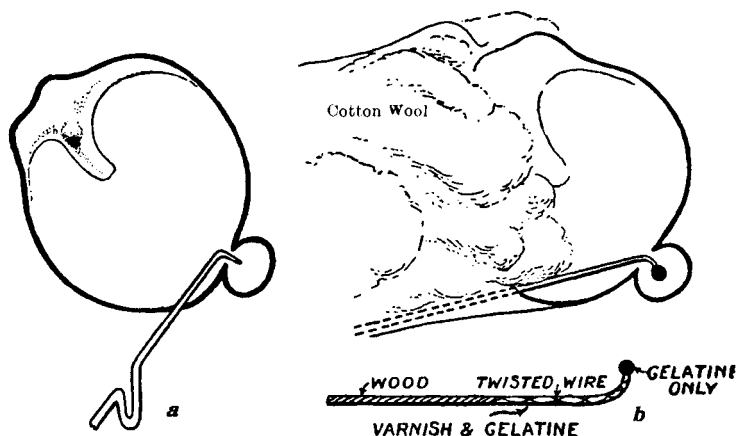

FIG. 49.—To show the method (*a*) of washing out a suppurating cell, and (*b*) of conveying the electric current to its walls.

or some other means, in order to introduce the instrument by which the electric current is distributed. The author uses the instrument illustrated (*Fig. 49*).

Some fine silk-covered wire is doubled, twisted, and fastened to a light wooden holder such as is frequently used for cotton-wool. The wire and end of the wood are dipped into some melted gelatin containing a zinc salt in solution and some glycerin. The instrument is hung 'business end down' so that a small blob of gelatin forms at the tip. After some hours the instrument is taken up, and the twisted wire—except the tip—and adjacent part of the wood are painted with an insulating

varnish and allowed to dry 'business end up'. This dries quickly and the instrument is ready for use. The last $\frac{1}{8}$ in. or so is bent at an angle and is passed into the opening of the cell, and a long wick of cotton-wool is carefully placed in the meatus in such a position as to keep the end of the wire in the cell. Zinc solution is poured on to this wool so as to keep the cell full. The gelatin keeps the end of the wire from touching the mucous-membrane lining of the cell, yet allows the current to flow; the varnish prevents the current being wasted in the middle ear and meatus. Naturally a weaker current is more suitable for such a cell than the current used for the middle ear. There is no doubt some of the current does escape into the fluid in the middle ear, but there is also no doubt from the satisfactory result which one obtains that the wall of the cell is ionized. The writer has much confidence in this technique.

When it is necessary to enlarge a perforation in Shrapnell's membrane and destroy portions of the outer attic wall, or to destroy portions of the upper posterior part of the drum, the writer uses one of the instruments illustrated in *Figs. 50, 51, 53*.

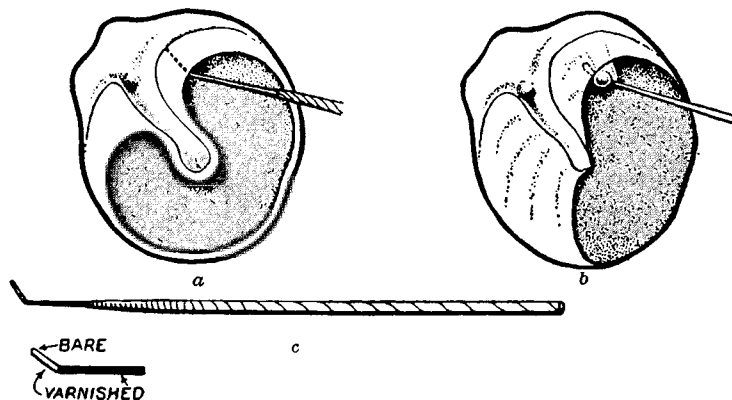

FIG. 50, *a, b, c*.—To destroy tissue over the long process of the incus. In *a*, a small quantity of discharge appears on aspiration; *b*, a granulation is visible in addition to the discharge; *c*, the insulated wire.

Fig. 50c represents a zinc wire which is insulated except at the side of the tip next the handle, which is of wood. It is

introduced through the perforation and destroys the outer wall from within by coagulating tissue. It is held in position by a wick of dry cotton-wool, and is attached to the positive pole. The negative electrode is placed on the arm. A feeble current for twenty minutes should be used. Patients are readily made giddy, and unless care is taken may vomit.

Figs. 51 and 52 illustrate a bipolar instrument. With it a much stronger current can be borne without discomfort. The

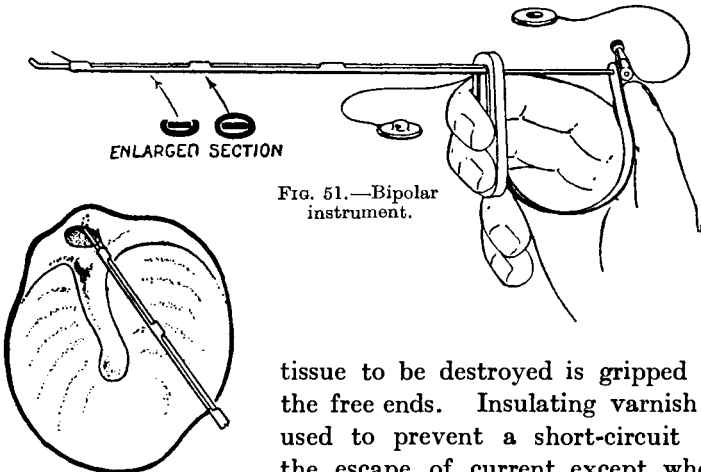

FIG. 51.—Bipolar instrument.

FIG. 52.—Applying the bipolar instrument.

tissue to be destroyed is gripped by the free ends. Insulating varnish is used to prevent a short-circuit or the escape of current except where it is in contact with the tissue to be destroyed. Five to three minutes is

sufficient, using a strength of 2 to 4 ma.

Fig. 53a shows a polypus instrument with fine zinc needles. The portion of tissue to be destroyed is punctured

Note on the treatment of a membranous annular stricture of the external auditory meatus.—Occasionally a membranous annular stricture, like a halfpenny with a hole in it, is seen in this situation. The writer has found treatment by electrolysis to be successful, and he considers this to be a more reasonable method of treatment than incision. With an incision there is an open wound with formation of a granulation and consequent cicatricial tissue. With zinc electrolysis the epithelium on the outer side of the stricture unites with the epithelium on the inner side underneath a sterile coagulum. There is little tendency to contraction.

with the needles. When the instrument as shown in *Fig. 53b* is monopolar it is connected to the positive pole. The sharp bent termination is of brass. If there is room in the ear a bipolar instrument can be used instead.

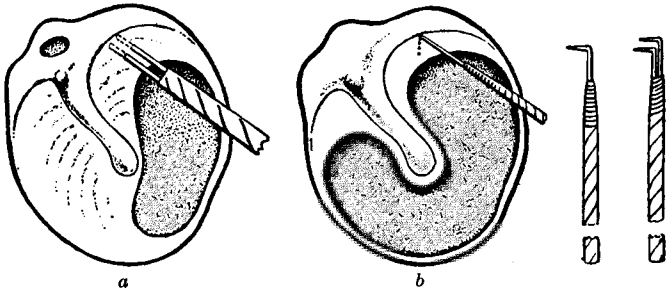

FIG. 53.

By the use of these instruments the tissue between a perforation in Shrapnell's membrane and a perforation in the posterior part of the drum can be destroyed (*Fig. 54*).

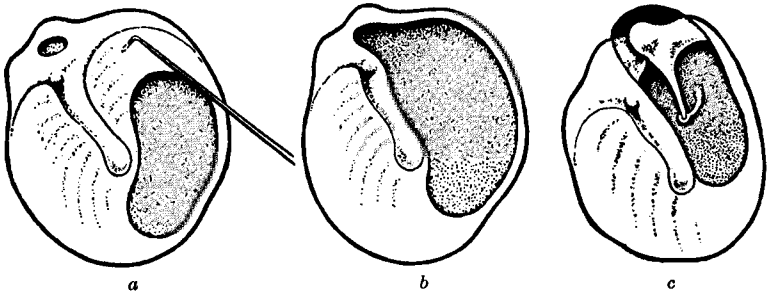

FIG. 54.

The use of these instruments requires the previous application of a local anæsthetic. The author uses Bonain's solution.

In the writer's experience, cases of tympanic sepsis recover quickly, and cases of polypi and granulations in the tympanum—provided there is not extensive disease of bone—also recover without much difficulty. Polypi or granulations appearing in a perforation in Shrapnell's membrane often take much time,

and require to be kept under observation for months. Recurrence of discharge after it has apparently ceased for weeks is not infrequent.*

Cases of an infected cell in the mastoid, as distinct from the antrum, for which the gelatin-covered wire is used, are not frequent, but the results are very good.

Cases of infection with discharge, at the upper posterior part—the incus area—are fairly frequent. The writer has expended much time and trouble on these cases. A small number recover, but a large number require a mastoid operation in hospital. The writer only attempts to use the method of treatment described above when the amount of discharge is small. In his experience, if an ear has been carefully cleansed and ionized on one or two occasions and does not show much improvement, some cause additional to tympanic sepsis will be found. It is useless to go on ionizing the ear; one should at once proceed to deal with this other factor. Occasionally—when, for example, one considers that there is caries of the handle of the malleus or caries in the tympanum—it is justifiable to use zinc ionization once every three weeks in order to assist recovery.

The economic value of zinc ionization in chronic suppuration of the middle ear is shown, firstly, in the large number of cases which recover quickly, and secondly, in the aid it gives in making an accurate diagnosis of the cause of chronicity. Strictly speaking, zinc ionization is not a remedy for chronic otorrhœa. It is a means of treating local sepsis in an accessible position. As this is frequently the sole factor responsible for keeping up suppuration, it follows that zinc ionization is often useful in cases of chronic otorrhœa. Moreover, in those cases in which the sepsis is in an inaccessible position, zinc ionization temporarily protects accessible areas from the irritation of septic fluid, and allows inflammation to subside and an

* Ether ℥j, Sp. Vini Rect. ℥ij, Menthol gr. iij. ℥j to be poured into the ear and allowed to remain for ten minutes, once or twice a week. The writer sometimes uses these drops in attic and incus area cases in private to remove accumulations of septic epithelial débris.

accurate diagnosis to be made. In the following table much of what has been said is summarized :—

INDICATIONS FROM THE CAUSE OF CHRONICITY AS TO TREATMENT.

<i>Cause of Chronicity.</i>	<i>Treatment.</i>
1. Accessible sepsis: e.g., most cases of tympanic sepsis.	Zinc ionization with or without boracic powder insufflation. In slight cases it is not necessary to ionize. Boracic powder alone is sufficient.
2. Accessible sepsis with second factor in ear: e.g., polypus.	Remove second factor, then ionize ear.
3. Accessible sepsis with inflammation in a neighbouring organ: e.g., rhinitis.	Treat neighbouring organ and ionize ear.
4. Inaccessible sepsis:	
a. Accessible with difficulty: e.g., cell in mastoid opening directly into tympanum.	a. Use special instruments to gain access: (i) Attic cannula; (ii) Gelatin-covered wire.
b. Totally inaccessible: e.g., most cases of attic disease, and of chronic mastoiditis.	b. Make area of sepsis accessible: e.g., destroy outer attic wall, ossiculectomy, partial or complete mastoid operation, and then ionize.

TREATMENT OF EXTERNAL OTITIS.

External otitis may be diffuse or circumscribed.

A *furuncle* is an example of the circumscribed form, and is an acute inflammation of a hair follicle. It is by no means an uncommon complaint and usually not serious. The writer adopts the treatment recommended many years ago by Dr. Woakes—painting the meatus, daily if possible, with tinct. iodi. In warm countries such as India the disease can be quite severe and give rise to much suffering. Dr. Norrie* treats such cases with a prolonged (two hours) application of salicyl ionization to the ear and surrounding skin, and has had much success.

To increase the antibacterial properties of the blood in cases of furunculosis, staphylococcus vaccine is much used. This has been successful in hastening the disappearance of the boil and in preventing recurrences.

Chronic diffuse external otitis—apart from any discharge from the middle ear—affecting the external auditory canal and

* *Journal of Laryngology and Otology*, 1927, p. 105.

sometimes invading the concha, occurs most frequently in girls. The disease may have existed for months when the patient comes for treatment. It may vary in intensity from a slight irritation due to decomposition of desquamated epithelium in the depths of the meatus, to discomfort due to inflammation with exudation from the skin of the meatus and auricle.

The slight cases require cleansing, and then insufflation of boracic powder on two or three occasions. In the severe cases the skin needs physiological rest. This may be afforded in more than one way. The surface may be sterilized and protected. When the canal and skin have been carefully cleansed, a solution of 2 per cent zinc sulphate in 15 to 20 per cent gelatin in water is melted, and poured into the canal. A strip of gauze is placed in this, and also spread over the concha if this is affected. The conchal hollow is filled with a pad of wool moistened with zinc sulphate solution or zinc gelatin. An electrode is placed in contact with this pad, and a long application (half to three-quarters of an hour) of the electric current at a strength of 3 to 4 ma. given. The gauze is allowed to remain in the meatus and concha for from four to five days. It is then removed, the canal is cleansed of as much gelatin as can be readily removed, and boracic powder insufflated. Zinc ionization should not be repeated at short intervals for fear of injuring the skin. In a few days the skin should show much improvement, and a protective ointment such as zinc can then be used. The depths of the meatus should be kept as dry as possible.

Another method of obtaining physiological rest is to soothe the nerves of the skin by ionizing with the salicyl ion. The meatus and concha should be filled with cotton-wool, and a solution (2 per cent) of salicylate of soda poured on the wool. The electrode is placed on the cotton-wool in the concha. The writer uses the same electrode as for middle-ear disease, and makes contact with the zinc wire by a wick of cotton-wool projecting from the speculum. The speculum and projecting wool rest on the wool in the concha. It is important not to obliterate the lumen of the meatus by a tight bandage, whether one treats the case with zinc or salicyl ionization. The dose

for salicyl ionization can be 3 to 4 ma. for half an hour, and the treatment can be repeated in a week if necessary. After the treatment the meatus should be dried and boracic powder insufflated to try to prevent any exudation from becoming septic.

Salicyl ionization may be followed at a week's interval by zinc ionization, omitting the gelatin if the ear is improving.

PAPERS AND RESULTS PUBLISHED.

Several papers have been published recently on the use of zinc ionization in chronic otorrhœa, among which may be specially mentioned :—

JOBSON, T. B., "Suppurative Otitis Media treated by Zinc Ionization", *Brit. Med. Jour.*, 1924, i, 371.

JOBSON, T. B., "Zinc Ionization in Tympanic Sepsis", *Jour. Laryngol. and Otol.*, 1926, June.

SCHMIDT, V., "Zinc Treatment of Chronic Otitis Media", *Hospitalstidende*, 1923, Sept.

HOLLENDER, A. R., and COTTLE, M. H., "Comparative Value of Physical Measures in Treatment of Chronic Purulent Otitis Media", *Clinical Medicine and Surgery*, 1927, Sept.

CAUSÉE, RAOUL, "L'ionization du Zinc dans la Thérapeutique otologique", *Ann. des Mal. de l'Oreille, etc.*, 1928, Jan.

NORRIE, F. H. B., "Indications for Ionization in Chronic Suppurative Otitis Media, with Notes on the Treatment of Attic and Antrum Infections", *Jour. Laryngol. and Otol.*, 1928, p. 786.

And among text-books giving an account may be noted :—

MCKENZIE, DAN, *Disease of the Throat, Nose, and Ear*, 2nd ed.

HOLLENDER and COTTLE, *Physical Therapy in Diseases of the Eye, Ear, Nose and Throat*.

The conclusions formulated by Dr. Jobson in one of his papers are : (1) Zinc ionization will cure any case of chronic otorrhœa which is curable by drops ; (2) It will accomplish this in one-hundredth part of the time, thus saving an enormous amount of the patient's, doctor's, and hospital's time ; (3) It will cure a large number of cases which do not mend with ordinary antiseptic treatment.

At various places this method of treatment is carried out in the School Medical Service, and statistics of the results obtained have been published. Tables are subjoined giving

some of these. The conditions found in the ears treated have been classified on an anatomical basis. This classification will be found almost to correspond with the classification of the causes of chronicity given on page 64, which is drawn up as a guide to treatment. *Table II* shows a series of cases in

Table II.—OTOLOGICAL CLASSIFICATION AND SUMMARY OF RESULTS IN A SERIES OF EARS TREATED BY IONIZATION.

Cause of Chronicity	Total	Cured	Lost Sight of	Still under Treatment	Sent for Operation or Other Treatment
1. Tympanic conditions:—					
<i>a.</i> Tympanic sepsis ..	251	234	17	—	—
<i>b.</i> T.S. + granulations ..	82	61	16	5	—
<i>c.</i> T.S. + polypus ..	29	18	5	8	8
<i>d.</i> T.S. + caries ..	4	2	2	—	—
<i>e.</i> T.S. + cholesteatoma ..	3	1	2	—	—
<i>f.</i> T.S. + other conditions	8	2	1	—	—
2. Tympanic conditions + involvement of Eustachian tube, nose, pharynx, or mouth	87	18	9	4	6
3. Tympanic conditions + attic or mastoid	173	85	40	11	87
<i>i.</i> No previous operation ..		24	33	6	72
<i>ii.</i> Operation already ..		11	7	5	15
4. Tympanic conditions + external otitis	14	9	2	1	2
Tympanic conditions + stricture of meatus ..	1	1	—	—	—
5. External otitis	12	9	2	1	—
6. Tympanic conditions + cause undetermined	7	4	2	1	—
Totals	616	394	98	26	98

school-children treated by the writer. It includes all cases during a certain time except some slight ones which were treated by the insufflation of boracic powder alone. The writer has a high opinion of the value of boracic powder. It absorbs and desiccates discharge whether septic or not, and prevents it irritating or becoming irritative. Dr. Lane Joynt used to teach that "microbes cannot fly or walk, but they can swim". The indications for its use are given on pages 45, 46.

Dr. Cramb, of the School Medical Service at Brighton, has kindly furnished the writer with a table of cases of chronic otorrhœa treated by zinc ionization, in which the cause of chronicity is specified.

Table III.—CASES IONIZED IN THE BRIGHTON SCHOOL MEDICAL SERVICE WHERE THE CAUSE OF CHRONICITY WAS NOTED.

Cause of Chronicity	Ionized	Cured	Not Cured	Lost Trace
Tympanic sepsis ..	107	97	7	3
Tympanic sepsis and granulations	68	47	21	—
Tympanic sepsis + swollen mucous membrane ..	13	8	5	—
Tympanic sepsis + small polypus	2	—	2	—

Table IV is taken from a paper by Dr. Gladys E. Ainscow in the *Birmingham Medical Review* for December, 1926. The treatment given was on the lines described in this book.

Table IV.—ANALYSIS OF CAUSES OF CHRONICITY AND SUMMARY OF RESULTS OF 270 CASES OF SUPPURATING EARS TREATED BY ZINC IONIZATION AT SMETHWICK SCHOOL CLINICS.

Cause of Chronicity	Total	Cases Cured	Lost Sight of	Still under Treatment	Referred to Hospital
Tympanic sepsis	114	110	—	4	—
T.S. + polypi	14	1	—	4	9
T.S. + granulations	20	11	6	3	—
T.S. + other conditions	4	1	—	2	1
T.S. + enlarged tonsils and adenoids	33	31	—	—	2
Tympanic conditions + attic and mastoid disease	26	—	11	4	11
External otitis	6	6	—	—	—
Tympanic conditions + causes undetermined	53	30	2	17	4
Totals	270	190	19	34	27

Dr. F. P. M. Clarke, Assistant Aurist, Liverpool Education Committee, has made much use of zinc ionization, and portions of his valuable reports are reproduced.

Table V.—CASES OF CHRONIC OTORRHOEA TREATED BY ZINC IONIZATION AT ALDER HEY CHILDREN'S HOSPITAL, LIVERPOOL, FROM JANUARY, 1923, TO JUNE, 1925.

Causes of Suppuration	Total	Cured	Left before Treatment Finished	Referred for Operation	Still under Treatment
<i>Chronic Suppurative Otitis Media</i>					
Tympanic conditions solely :—					
a. Tympanic sepsis	148	141	2	—	5
b. T.S. + granules	56	37	5	5	9
c. T.S. + polypi	15	9	2	2	2
d. T.S. + caries	8	3	1	4	—
e. T.S. + cholesteatoma ..	2	—	—	2	—
Tympanic conditions combined with :—					
a. Tonsils and adenoids ..	30*	26	2	—	2
b. Nasal conditions	11	9	1	—	1
Tympanic conditions combined with :—					
a. Attic sepsis	7	4	—	3	—
b. Mastoid disease :—					
i. No operation	14	3	6	5†	—
ii. After operation	13	11	—	—	2
Tympanic conditions combined with :—					
a. External otitis	5	5	—	—	—
b. Stricture of meatus ..	4	1	1	2	—
<i>External Otitis</i>	7	7	—	—	—
Totals	320	256	20	23	21

* Tonsils and adenoids 'removed' in 30 cases.
 † Operation advised, but refused, in 5 cases.

Table VI.—REPORT OF CASES OF CHRONIC OTORRHŒA TREATED BY ZINC IONIZATION AT LIVERPOOL IN 1925 AND 1926.

Causes of Suppuration	Total	Cured	Left School	Referred for Operation	Still under Treatment
<i>Chronic Suppurative Otitis Media</i>					
1. Tympanic conditions solely :—					
a. Tympanic sepsis	163	158	—	—	5
b. T.S. + granulations	75	45	5	4	21
c. T.S. + polypi	12	4	—	4	4
d. T.S. + caries	7	1	—	—	6
e. T.S. + cholesteatoma	1	—	—	1	—
2. Tympanic conditions combin e with :—					
a. Tonsils and adenoids	22*	20	1	1	—
b. Nasal conditions	15	15	—	—	—
3. Tympanic conditions combined with :—					
a. Attic disease	10	2	—	1	7
b. Mastoid disease :—					
i. No operation	19	1	3	12	3
ii. Previous operation	5	2	—	1	2
4. Tympanic conditions combined with :—					
a. External otitis	8	8	—	—	—
b. Stricture of meatus	4	3	1	—	—
<i>External Otitis</i>	1	1	—	—	—
Totals	342	260	10	24	48

* Tonsils and adenoids: Removed, 17; cured, 17. Not removed, 5; cured, 3; left school, 1; referred for operation, 1.

Table VII.—REPORT OF CASES OF CHRONIC OTORRHOEA TREATED BY IONIZATION AT LIVERPOOL DURING 1927.

Causes of Suppuration	Total	Cured	Left School	Referred for Other Treatment	Still under Treatment
<i>Chronic Suppurative Otitis Media</i>					
1. Tympanic conditions :—					
<i>a.</i> Tympanic sepsis ..	222	209	—	—	13
<i>b.</i> T.S. + granulations ..	93	64	8	8	13
<i>c.</i> T.S. + polypi	17	7	1	4	5
<i>d.</i> T.S. + caries	28	2	2	13	11
<i>e.</i> T.S. + cholesteatoma ..	3	—	—	3	—
2. Tympanic conditions combined with :—					
<i>a.</i> Tonsils and adenoids ..	51*	30†	4	15	2
<i>b.</i> Nasal conditions	41	33‡	—	—	8
3. Tympanic conditions combined with :—					
<i>a.</i> Attic disease (sepsis) ..	18	7	1	7	3
<i>b.</i> Mastoiditis (chronic) ..					
<i>i.</i> No operation	20	2	1	9	8
<i>ii.</i> Previous operation ..	11	5	1	2	3
4. Tympanic conditions combined with :—					
<i>a.</i> External otitis	19	16	—	—	3
<i>b.</i> Stricture of meatus	6	2	—	—	4
<i>External Otitis</i>	13	11	—	—	2
Totals	542	388	18	61	75

* Tonsils and adenoids: total, 51. Tonsils and adenoids removed, 15; to have tonsils and adenoids removed, 15.

† Fifteen tonsils and adenoids removed.

‡ Thirteen treated by diastolization for the nasal condition.

SPECIAL REPORT OF LIVERPOOL EDUCATION COMMITTEE.

Below is given the substance of a special report on the 'following up' of the results of cases of chronic otorrhœa treated by zinc ionization and discharged 'cured' in 1925-6, with a view to determining the 'permanency' of the cure in these cases.

It is well to state here what the term 'cured' signifies, used when a case is discharged after treatment by ionization. When a 'running' ear is ionized for the first time, it is usually examined again in the course of four to seven days. If 'dry', no further treatment is now given. If any discharge is present, ionization is repeated at about seven days' interval, and so on. When a case is 'quite dry' for four consecutive weeks, it is then discharged 'cured'—to return for observation in one month.

Every case is four weeks 'dry' before being discharged 'cured'.

The questions have been frequently asked, and wisely too, "Is ionization a permanent cure, or does the ear simply 'dry up' for a short period and then does the discharge recur? What is the tendency to permanent cure in cases of chronic otorrhœa which have had a profuse discharge for years, although having had more or less regular treatment by 'syndring and drops'; when such cases are once 'dried up' by zinc ionization, are they, at the end of, say, twelve months, still 'dry'?"

With the object of investigating this important matter, it was decided to 'follow up', and examine at certain intervals, all the cases discharged 'cured' in 1925-6. (Liverpool Education Committee.) Practically all the cases were personally examined by the medical officer in charge of the treatment. This was done to ensure a true return, as the parents' or patients' reports may not be correct.

Cases were examined at the end of the 1st, 3rd, 6th, 9th, and 12th month; and also between 12 and 18 months, between 18 and 24 months, and over 24 months if sufficient length of time had existed since their discharge from the clinic.

The total number of cases discharged 'cured' (1925-6)

have been classed in three groups, according to the length of time that they have been discharged :—

- Group 1.—Discharged ‘cured’ up to 12 and from 12 to 18 months.
- Group 2.— ” ” ” from 18 to 24 months.
- Group 3.— ” ” ” over 24 months.

Table VIII.—REPORT OF 260 CASES OF CHRONIC OTORRHOEA TREATED BY ZINC IONIZATION AT LIVERPOOL IN 1925–6 AND DISCHARGED ‘CURED’ 12 MONTHS AND OVER.

	Group 1 (Up to 12 months and from 12 to 18 months)	Group 2 (18 to 24 months)	Group 3 (Over 24 months)	Total
Ears remaining ‘dry’ throughout	95	69	45	209
Relapsed, and again treated by ionization	17	12	3	32
Totals	112	81	48	241
Left school and untraced	—	—	—	19
				260

The 241 cases (out of 260) discharged as ‘cured’, which have been periodically examined and ‘followed up’ since their discharge, show interesting results. Out of the 241 ‘cured’, 209 have remained quite dry for varying periods over 12 months ; 32 cases relapsed after ionization treatment, roughly 13 per cent. All these 32 have had ionization repeated, and many have had no further relapse, and passed 12 months. A small number have relapsed two or three times at intervals of two to six months.

Analysing the 32 cases that have relapsed, it was found :—

- 17 occurred within the 12 and up to 18 months (out of 112)
- 12 ” between 18 and 24 months (out of 81)
- 3 ” over 2 years (out of 48).

GROUP 1.—Within the 12 months and between 12 and 18 months (17 out of 112). Out of the 17 relapsing :—

- 10 relapsed within 3 months
- 4 ” between 6 and 9 months
- 2 ” after the 9th month
- 1 ” at the end of 12 months.

The 'causes of chronicity' diagnosed in these cases were (following Friel's system of classification):—

Of the 10 (3 months):

7 were 'tympanic sepsis + nasal conditions' and were all under the age of 9 (rhinitis)

2 were 'T.S. + granulations'

1 was 'T.S. + tonsils and adenoids' (not operated).

Of the 4 (6-9 months):

2 were 'T.S. + polypi'

1 was 'T.S.'

1 was 'T.S. + previous mastoid' (operated 6 months)

Of the 2 (over 9 months):

2 were 'T.S. + granulations'

One (12 months):

'T.S. + rhinitis' (deviated septum).

TOTAL: 17.

GROUP 2.—18 to 24 months (12 relapses out of 81).

7 were 'T.S. + rhinitis'

1 was 'T.S. + polypi'

1 was 'T.S. + adenoids'

2 were 'T.S. + attic' (doubtful?)

1 was 'T.S.' (went three or four times to the swimming baths, again ionized, and dry over 6 months).

GROUP 3.—Over 2 years (3 relapses out of 48).

2 'T.S.' (went a few times to the swimming baths)

1 'T.S. + tonsils and adenoids' (not operated).

Notes and Summary.—

1. Generally speaking, the number of relapses in cases of simple tympanic sepsis, without complications, properly treated by zinc ionization, are extremely few.

2. The tendency to relapse is greatest during the first six months after treatment.

3. There also appears (?) to be a greater tendency to relapse amongst the younger children—below 8 years of age.

4. The frequency of the association of rhinitis with relapse is notable; hence the importance of treating the 'nasal conditions' and instructing patients or parents to pay particular attention to this.

5. When cases remain 'quite dry' over 12 months, the chances of relapse are very small—about 6 to 7 per cent as against about 15 per cent in the first 12 months.

The complications most commonly associated with recurrences of otorrhœa are: (a) rhinitis (especially in young children); (b) granulations; (c) polypi; (d) large masses of adenoid tissue. After-care directed to (a) keeping the ear perfectly dry by avoiding swimming, etc., and (b) attending to 'nasal conditions', is of importance.

Dr. Wells, Senior Aurist, School Medical Service, London County Council, has also kindly furnished me with the statistics of cases of chronic otorrhœa which he has treated with zinc ionization in 1927 on the lines described in this book.

Table IX.—CASES OF CHRONIC OTORRHŒA TREATED BY ZINC IONIZATION IN THE MEDICAL SERVICE OF THE LONDON COUNTY COUNCIL IN 1927.

Cause of Chronicity	Total	Cured	Sent to Hospital	Lost sight of or still under Treatment
<i>Chronic Suppurative Otitis Media</i>				
1. Tympanic conditions :—				
a. Tympanic sepsis	280	242	—	38
b. T.S. + granulations	62	52	—	10
c. T.S. + polypi	11	8	—	3
d. T.S. + other conditions ..	21	16	—	5
2. Tympanic conditions combined with :—				
a. Tonsils and adenoids	86	64	—	22
b. Nose conditions	63	49	—	14
3. Tympanic conditions combined with :—				
a. Attic disease	35	15	12	8
b. Mastoid disease	100	—	98	2
4. Tympanic conditions combined with stricture of meatus				
.. ..	1	1	—	—
<i>External Otitis</i>	4	4	—	—
Totals	663	451	110	102

CHAPTER IX.

THE USE OF ZINC IONIZATION IN THE EARLY POST-OPERATIVE STAGE
OF ABSCESS IN THE BRAIN.

AFTER an abscess in the brain has been opened, suppuration may last for a considerable time. Dr. Jobson has recorded in the *Transactions of the Royal Society of Medicine* (1923, vol. xvii, pp. 48 and 68) the history of the illness of two patients in which the abscess was secondary to disease in the ear.

The first case was a boy, age 13, admitted to hospital with pain and offensive pus in the left ear, slight rise of temperature, and headache. Spontaneous nystagmus was present. A radical mastoid operation was done, and a small extradural abscess was found posterior to the antrum. As the symptoms did not subside after the operation, and as vomiting had occurred, the dura was incised on the fourth day and about half an ounce of foetid pus evacuated from the cerebellum. The subsequent progress of the case was marked by 'flare-ups', with a return of headache and vomiting. The sinus in the brain was reopened more than once and a drain reinserted. Dr. Jobson then determined to try to get rid of the sepsis in the abscess track in the cerebellum by zinc ionization. He introduced into the track a zinc wire enveloped in cotton-wool soaked in zinc sulphate solution. A dose of 4 ma. for 15 minutes was given. There was no further trouble, and the track healed without any further suppuration. The boy was subsequently shown at a meeting of the Otological Section of the Royal Society of Medicine.

Shortly afterwards Dr. Jobson had a case of a woman, age 26, who was admitted to hospital suffering from headache, vomiting, and giddiness, as well as pain and tenderness in the right mastoid; temperature 102°. There was a history of discharge from the right ear since childhood. At the

radical mastoid operation the antrum was found to be full of pus, and just above the roof of the antrum a small extradural abscess was discovered. The dura was covered with granulations but was not necrotic. After the operation the symptoms subsided and she progressed favourably till the eleventh day, when she complained of headache and vomiting. A blood-count showed a large increase in the number of leucocytes, 93 per cent of which were polymorphs. Two days later nystagmus appeared, and the ophthalmic surgeon reported that the edges of the optic discs had an indistinct outline. The wound was reopened, and an abscess was found in the temporo-sphenoidal lobe at a depth of 1 in. and about the size of a hen's egg. Fœtid pus was evacuated and the abscess drained. On the fourth day after operation the abscess track was treated with zinc ionization, and this was repeated in a week, and twice later at intervals of a week. After the second ionization discharge was minimal. No anti-septics beyond zinc ionization were used, and the patient made a good recovery and was shown at a meeting of the Otological Section.

These are the first recorded cases of abscess in the brain in which the abscess has been treated after operation by zinc ionization.

*PART III.***AURAL CLINICS :****THE IMPORTANCE OF POLICY AND OF ORGANIZATION.**

CHAPTER X.

ECONOMIC IMPORTANCE OF ZINC IONIZATION IN THE TREATMENT OF CHRONIC OTORRHŒA IN SCHOOL-CHILDREN—ORGANIZATION OF A CLINIC.

IN this chapter is considered the question of how to deal in an economical manner with the large number of cases of otorrhœa which are met with in children attending elementary schools, for whom the school medical service is designed. It is a matter of adopting a correct policy and devising a good organization.

Policy implies the existence of an aim or objective, and the course of action which we adopt to reach the objective is our policy. There may be several lines of action open to us, but the policy to be desired is that which permits us with the least waste of time, energy, and material to deal with the large numbers of cases of otorrhœa which are awaiting treatment.

We have in view the desirability not only of treating the cases of chronic otorrhœa which exist, but also of preventing those cases of acute otorrhœa which may occur from becoming chronic.

It is to be hoped that, when housing conditions have been improved and when waste has been abolished in industry and through drink, the physical condition of the children will improve so much that they will become less liable to infections. However, although that is the *ultimate* aim, our *immediate* aim is to treat existing cases.

To deal especially with cases of chronic otorrhœa in school-children, aural clinics have been established. The majority

of children needing treatment go in the first instance to the school centre. A few go to hospital or to a private doctor. The medical officer at the centre can send children to special departments such as those for the eye, the teeth, or the ear.

We have to ask ourselves, "What cases of otorrhœa shall we send to the aural clinics? Shall we send all cases, acute as well as chronic, or only selected cases? If we send selected cases, who shall do the selection?" The aural clinics of necessity undertake in every case of chronic otorrhœa seen: (1) The diagnosis of the cause of chronicity; and (2) The administration of the treatment suitable. It will be evident that to make a selection of cases to send to these clinics often implies sending those which have been unsuccessfully treated, and this means that the same case is 'handled twice'. In a cash business the transaction 'selling the article and receiving payment' is handled once only; whereas in a credit business the transaction is handled at least twice. There is an addition to the price or a diminution of the profits—in either case unproductive expenditure. So, if selected cases only are sent, there is an increase in the number of examinations, the amount of treatment, the amount of time spent by the patient and his relatives, and the amount of time given by a paid staff.

In discussing the treatment of otorrhœa one realizes that cases get well under various forms of treatment. The special advantage claimed for the treatment described in this book is that the result is much more rapidly obtained, and that in difficult cases it renders it more easy to make a diagnosis. It seems therefore to incur waste to confine the treatment to selected cases. A correct policy would seem to be to send all cases as quickly as possible to the special clinic.

If we make use of an illustration the correct line of action will be plainer. When a tumblerful of fresh milk is allowed to stand it separates into two layers—a narrow upper layer and a deep layer beneath. The layer of cream may be taken to represent those cases of otorrhœa in which the area of sepsis is totally inaccessible and in which an operation in hospital is necessary. The deeper layer includes all those which can be treated in the clinic. We may assume that near the cream

will be placed those cases in which the area of sepsis is only accessible by the use of special instruments ; beneath these are the cases of polypi ; and reaching to the floor are a large number of simple cases in which sepsis alone in an accessible position is responsible for keeping up the suppuration. If we send to a clinic all the cases from a restricted area, it will be like a tumblerful of milk, and the line of attack will be in the vertical direction ; if we send selected cases only (naturally the most difficult), it will be as if we attacked the cases in horizontal layers. The number of results obtained under the latter policy will be small, and many of the easy cases which have not been sent will have their cure delayed, and a few will have acquired complications.

If we send, or attempt to send, to a clinic all the cases from an *unlimited* area, it will be as if we were dealing with a milk pan instead of a tumbler. Although the cases are not intentionally selected, it amounts in practice to sending selected cases, for the number of long-standing cases which are at once put on the list means that we never penetrate to any depth beyond the cream, for the supply of difficult cases is always being added to by the fact of the long delay in reaching those which have not yet developed complications.

The results obtained by confining our attention to a restricted area are much greater in number than if we deal only with cases intentionally selected by others from either a limited or an unlimited area, or, if the cases are unintentionally selected, by being sent from over a very large area.

Someone may naturally at once think, "But there are not enough clinics to which to send them".

It may be suggested that it would be a good thing to teach those of the school doctors who wish to undertake this work, who see the cases in minor ailment treatment centres at the commencement, to recognize the cause of chronicity, and to be able to decide on a correct line of treatment. In most cases this is of extreme simplicity ; in a few it is difficult, and needs a good deal of practice to apply with a prospect of success. Although this would involve handling some of the cases twice, the writer strongly supports, and when he has the

opportunity adopts, this line, for it must be remembered that there are not enough specialists to cope with the whole of the work.

Therefore under existing circumstances he would like to see ionization treatment carried out by all school medical officers who desire to undertake it, and the difficult cases sent by them to specialists.

ORGANIZATION OF THE WORK.

Organization may be defined as arrangements for getting work done. Good organization means arrangements for getting work done without waste, i.e., needless expenditure of money, energy, and time. The problem of how to secure this is not an easy one to solve, and as far as the writer can see it can only be satisfactorily solved by the 'experimental method'. Professor Claude Bernard gave a description of this method. There are three steps involved :—

1. The recognition of the problem to be solved. This includes an analytical examination of it to discover whether it is a simple or a composite one. The composite problem requires breaking up so that each component may be considered separately. Not only the factors inherent to the problem, but also the circumstances in which it has to be solved, have to be taken into account.

2. The formation of a hypothesis : a suggested scheme.

3. The testing. The scheme is tried on a small scale, and the result may confirm the suggestion, or may show that it needs modification or is unsuitable. If the test proves satisfactory the scale of application can be confidently extended.

The problem that we have to solve is how to get the maximum number of cases efficiently treated at a clinic. The principal factors we have to consider are :—

- a.* The conditions in a number of discharging ears. There are the cases in which the condition is simple and easily dealt with. The patients take up only a short time and need only a few visits. There are the cases in which there are multiple conditions. In these patients the treatment occupies a considerable time and many visits are needed. There are also

the cases in which the conditions are such that an operation in hospital is required.

b. The circumstances of the patients and their relatives : Are the latter at work ? Can they bring or send the child easily to the clinic ? etc.

The agents at our disposal in the clinic are :—

a. A certain duration of time. A session at a clinic lasts two to two and a half hours.

b. A staff consisting of a lady organizer, or a clerk who undertakes the office work ; one or two nurses, and a doctor. They furnish skill and energy. Skill is not perfect, and energy is limited.

c. The equipment.

When an aural clinic is started it is necessary to have a list of names of all the patients suffering from otorrhœa. This is obtained from the minor ailment department, from the medical inspection at the schools, from nurses and teachers detecting cases. The names are entered in a book and the cases are brought to the aural clinic in rotation, new cases being constantly added to the list. Gradually the accumulation of old cases is worked through.

A new case is not allowed to come to the clinic direct, but is given an appointment as soon as there is a vacancy. If, however, a child with acute mastoiditis or acute earache came to the clinic without an appointment he would be seen. The patients pass through the session of a clinic in Indian file, so it is important that the procession should not be held up. If care is not taken it is possible to have 'hold-ups'.

A doctor has only a certain amount of energy. The number of patients who come is limited to the average number which experience shows he can see and treat. When he commences ear work this number is small, but after some time he will be able to deal with twenty at a session.

Once the session has begun the time is slipping away. An effort is made so to arrange matters that the work of all may commence at once. Ionization treatment, including the examination and technique of preparation, needs a good deal of time, and if care is not taken in arranging the work

it will be found that if the time of the session is not utilized continuously there will not be enough to give ionization treatment to all those who need it.

The apparatus should be sufficient in quantity. Apparatus once bought needs a trifling expense to maintain. It is uneconomic to restrict the number of patients who can be treated at a session by providing too little apparatus. Two ionization sets are needed, at least when a clinic is started. The staff at these clinics are all paid and the number of patients awaiting treatment is often large, so we want the procession to go through steadily.

Assuming that the apparatus is sufficient, the organization has to concern itself with two quantities : (1) The energy of the staff and patients ; (2) The duration of the session. As the time of the latter slips away steadily and can neither be hastened nor retarded, it follows that the primary agent of which account must be taken is time. Not only is it necessary to take into account the actual time spent by patients in the treatment room, but we must remember that the time of the patient and his relatives may be wasted by sitting in a waiting-room. To minimize this waste of time and avoid friction, which is a needless expenditure of energy, written appointments are given to each patient, stating the exact hour and the date at which they are expected to attend. This is done both for the first and subsequent visits.

Dr. Chaikin pointed out to the writer that the secret of success in the treatment of children is to enlist the help of the mother. The majority of patients coming to these clinics are from homes in which there is not much superfluity. The time of the mother is valuable as she has much work to do, and if we do not waste her time we are more likely to get willing co-operation. Nobody likes to be brought at 9.30 and to have to sit on a bench for an hour.

The sessions are held once a week from 9.30 to 12, or from 2 to 4.30, and a page in a book or a column in a page is allotted to each session. When an appointment is made, the name of the patient is written on the page or column opposite a certain time. For each session there is, then, a series of intervals and

a series of names. The patients are called in the order in which their names are in the book, and not in the order in which they choose to come to the clinic. If a patient who has an appointment for 11 chooses to come at 9.30 that is her look-out. She soon finds that we mean business, but we try to give each patient the hour which is most convenient to her.

It was pointed out that among the cases are long ones such as those in which the incus area is involved, or cases of polypus; and 'short' cases such as tympanic sepsis only, or with some small granulations. The long cases need the application of a local anæsthetic. It does not mean that these cases take up the time of the staff all the while they are in the room, but it does require that the long cases should not be brought in immediately one after the other at any part of the session. They require to be spaced out. The author finds that he can treat at most four long cases in a session, and arranges that they should be brought, say, one at 9.30, one at 10, one at 10.30, and one at 11. It is necessary to call in these long cases at the time arranged even if other patients are waiting.

He finds it an advantage to have more than one patient in the room at the same time. If the room is large he does not object to it serving as a waiting-room as well as treatment-room. One patient sees how another is treated, and that he need not expect anything dreadful.

The writer has had experience of the system he has outlined, and of the system in which the patients are told to be present before such an hour or between such and such a time and are then seen in the order in which they come. He would not return to the old system. He began making appointments when a clinical assistant at the Royal Free Hospital, and the comment of the out-patient porter, Mr. Johnson, may be cited: "It is much better for me to have these card appointments than a bench full of discontented people." The writer is convinced that good treatment has little chance of success in a badly organized clinic.

It may be an advantage to give a sample time-table and

also a summary of the arrangements for a session of an otorrhœa clinic.

Arrangements for a Session of an Aural Clinic.—A sufficient number of patients to be called to ensure an attendance of twenty.

The patients are to be given appointments. The time of each session is to be spaced off into intervals, and each patient is to be given a card at each visit on which is to be written clearly the exact time at which he is expected to attend, as well as the date.

The hour given to a patient is to depend on: (1) The intervals available on the date at which he is asked to come; (2) The available interval which is most convenient to the patient or his relatives.

Certain cases known as 'attic' or 'long' cases are to be *spaced out* in the session as shown in the time-table drawn up. These cases are to have precedence over other patients,

SAMPLE TIME-TABLE.

	Name of Patient	Hour of Appointment
1	*John Fulger ..	9.30
2	Mary Evans ..	9.30
3	†Julia Halford ..	9.30
4	†Winnie Ronayne ..	9.45
5	Philip Soames ..	9.45
6	*Thomas Hatford ..	10.0
7	Margaret Connor ..	10.0
8	†James Tweedy ..	10.0
9	Rob Robinson ..	10.15
10	Mary Flynn ..	10.15
11	*Agnes Rorke ..	10.30
12	†Edward Brown ..	10.30
13	Sammy Metcalf..	10.30
14	John Lowther ..	10.45
15	Fred Chapman ..	10.45
16	*Thomas Athill ..	11.0
17	Jim Lothbury ..	11.0
18	Mollie Flower ..	11.0
19	Violet Beaumont ..	11.15
20	Alfred Maguire ..	11.15

* = long case; † = new case.

and are to be called in at the particular time opposite their names, even though it may happen that patients with an earlier appointment have not been all called in. Otherwise

the patients are to be called in according to the order in which they are written down in the organizer's list, and not according to the order at which they may chance to come to the clinic. If a patient, however, is late for his appointment, the doctor is to be informed and he will determine when he is to be called in.

Records.—It is important to keep accurate records of the cases seen at the clinics. Zinc ionization is a comparatively recent method of treatment, and to obtain a fair idea of its value it is necessary to realize not only the conditions in which it is of use, but also those in which it is not likely to be of benefit. The results obtained in a considerable number of cases enable a judgement of its value to be formed.

The card system is used at the clinics, and in addition the name of each child is entered in a book with alphabetical divisions. Each page (or each opening, according to the size of the book) is ruled into at least four columns headed—

<i>Name</i>	<i>Cause of Suppuration</i>	<i>Treatment</i>	<i>Result</i>
-------------	-----------------------------	------------------	---------------

and under these headings a summary is entered from the cards. At intervals the writer looks down the column of results, and if nothing is entered in this column opposite a particular name the card is looked up to see whether the child has ceased to attend, or is still under treatment, etc.

The writer has found this book of much help. It saves time, since it is possible to obtain the information desired more rapidly than by going through all the cards, and it also simplifies the work of making up the annual returns.

A Clinic is to be Regarded as a Unit.—From the foregoing it is clear that the facilities provided and described for dealing with a number of patients constitute a *unit*. A piece of brass weighing a pound is a unit weight by which we are able to separate off definite quantities from a mass of material. To alter the weight of the brass would render it unfit for the purpose. Similarly, to alter the constituent parts of a clinic would prejudice its economic working. The number of patients bears a definite relation to the time, staff, and equipment of a clinic.

No attempt should be made to increase the number of patients attending a session, but the sessions should be multiplied if the number of patients requiring treatment justifies it.

When an aural clinic is opened to deal with the cases of otorrhœa attending minor ailment treatment centres, it is found that for some time the work of the clinic is almost entirely taken up by the chronic cases. As the accumulation of these is gradually worked through, it becomes possible to deal with the acute cases as they arise and so prevent their becoming chronic.

At the Aural Clinic at Bruce Castle in Tottenham there were seen:—

In 1924-5,	213 cases of otorrhœa, of which 6 were acute
„ 1926,	181 „ „ „ 27 „ „
„ 1927,	204 „ „ „ 92 „ „

The school population of Tottenham is about 25,000, and it is found that one session a week during school terms is capable of dealing with all the cases. There is now no 'waiting list', and has not been for a considerable time. The detailed statistics for 1927 are given in *Table X*.

Table X.—TOTTENHAM OTORRHŒA STATISTICS FOR 1927.

Cause of Suppuration	Total	Cured	Lost Sight of	Still under Treatment	Needing Hospital
Acute suppurative otitis media	92	85	1	5	1
Chronic otorrhœa due to tympanic conditions:					
a. Tympanic sepsis ..	46	44	1	1	—
b. T.S. + granulations ..	7	4	2	1	—
c. T.S. + polypus ..	7	3	1	3	—
Tympanic conditions:					
+ Pharyngitis	1	1	—	—	—
+ Rhinitis	3	2	1	—	—
Tympanic conditions:					
+ Attic disease	14	6	2	3	3
+ Mastoid disease ..	12	3	—	1	8
Cause undetermined	2	1	1	—	—
External otitis	20	17	2	1	—
Total	204	166	11	15	12
Percentage	100	81·3	5·4	7·3	5·8

INDEX

	PAGE		PAGE
Acute suppurative otitis media	1-3, 49	Galvano-cautery - -	18, 30
Adenoids - - -	57	Gelatin-coated wire - -	59
Albumin, zinc and	11, 12, 16, 17, 18	Granulations - - -	52
Ampère - - -	23	Ion - - - -	6-8
Anatomical illustrations	35, 36, 37	Ionization - - - -	11, 12
Anion - - -	9	Instruments	32, 33, 34, 53, 59, 60, 61
Anode - - -	9	Intratympanic irrigation	43, 47
Aspiration - - -	32, 40	Kathode - - - -	9
Attic cannula - - -	43, 47	Kation - - - -	9
„ disease - - -	-60, 61, 62	Metals - - - -	5
Bacteria, action of zinc on -	19	Milliampère - - - -	23
Battery, electric - - -	25	Molecule - - - -	5
Bonain's solution - - -	31	Nozzle of douche can - -	38
Boracic acid powder - - -	-45, 46, 67	Ohm - - - -	24
Brain abscess - - -	76	Organization - - - -	81-84
Burns - - - -	14, 28	Picric acid - - - -	45
Caries - - - -	56	Poles, to distinguish - -	15
Cause of chronicity - - -	-41, 63, 64	Policy - - - -	78-81
Chlorine - - - -	-5, 14	Polypi - - - -	53-55
Cholesteatoma - - -	56	Records - - - -	67-75, 86, 87
Chronic suppurative otitis media	1-4, 49, <i>et passim</i>	Recurrences - - - -	73
Copper - - - -	20	Results	45, 46, 48, 49, 62, 63
Coulomb - - - -	23	Rheostat, Leduc's water	26
Current, electric - - -	6-9	Rheostats, wire - - -	25, 27
Diagnosis - - - -	41, 46	Salicyl ion - - - -	-6, 65
Diastolization - - -	57	Salt, groups in a - - -	5
Discs, breathing - - -	57	Sepsis - - - -	3, 42
Electrode - - - -	8	Shrapnell's membrane	-36, 39, 61
„ ear - - - -	28, 45	Solutions - - - -	31
„ indifferent - - -	12, 28	Stricture of meatus - -	61
Electrodes, action at - - -	13, 14	Volt selector - - - -	27
Electrolysis - - - -	9	Voltaic cell - - - -	6, 7
Electrolyte - - - -	8	Zinc ions - - - -	6, 16-20
Electron - - - -	5	„ ionization	12, 15, 27-30, 44
Ether - - - -	38	„ needles - - - -	53
External otitis - - -	64		
Furuncle - - - -	64		