

ANISI • DOMINVS • AEDIFICAVERIT • DOMVM

MODERN HOUSE
CONSTRUCTION



THE PRINCIPLES AND PRACTICE
OF
MODERN HOUSE-CONSTRUCTION



THE PRINCIPLES AND PRACTICE
OF
MODERN HOUSE-CONSTRUCTION

INCLUDING

WATER-SUPPLY AND FITTINGS—SANITARY FITTINGS AND
PLUMBING—DRAINAGE AND SEWAGE-DISPOSAL—WARMING
VENTILATION—LIGHTING—SANITARY ASPECTS OF FUR-
NITURE AND DECORATION—CLIMATE AND SITUATION
STABLES—SANITARY LAW, &c.

WRITTEN BY

| | |
|--|---|
| F. W. ANDREWES, M.D., F.R.C.P., D.P.H. | PROF. ROBERT KERR, F.R.I.B.A. |
| A. WYNTER BLYTH, M.R.C.S., F.I.C. | HENRY LAW, M.Inst.C.E., F.San.I. |
| H. PERCY BOULNOIS, M.Inst.C.E., F.San.I. | F. W. LOCKWOOD, F.I.S.E. |
| E. A. CLAREMONT, M.I.E.E., M.I.M.E. | J. MURRAY SOMERVILLE |
| HENRY CLAY, R.I.Pl. | W. SPINKS, A.M.Inst.C.E., Pr.I.S.E. |
| E. R. DOLBY, A.M.Inst.C.E., M.I.M.E. | G. LISTER SUTCLIFFE, A.R.I.B.A., M.San.I. |
| WILLIAM HENMAN, F.R.I.B.A. | WILLIAM H. WELLS |
| H. JOSSÉ JOHNSON, M.B., D.P.H. | E. F. WILLOUGHBY, M.D., D.P.H. |

KEITH D. YOUNG, F.R.I.B.A.

EDITED BY

G. LISTER SUTCLIFFE

ARCHITECT

ASSOCIATE OF THE ROYAL INSTITUTE OF BRITISH ARCHITECTS, MEMBER OF THE SANITARY INSTITUTE
AUTHOR OF "CONCRETE: ITS NATURE AND USES", ETC.

ILLUSTRATED BY ABOVE 700 FIGURES IN THE TEXT, AND A SERIES OF SEPARATELY-PRINTED PLATES

1782

21.2

DIVISIONAL-VOL. III.

LONDON: BLACKIE & SON, LIMITED
GLASGOW AND DUBLIN

With regard to the Illustrations in Divisional-Volume III., indebtedness has to be acknowledged to the following:—Messrs. Jos. Cliff & Sons, Wortley, near Leeds; Dent & Hellyer, London; Doulton & Co., Lambeth; John Jones, Chelsea, London; Oates, Green, & Co., Ltd., Halifax; Milton Syer, London.

CONTENTS.

DIVISIONAL-VOL. III.

SECTION VII.—SANITARY FITTINGS.

By KEITH D. YOUNG, F.R.I.B.A.

| | Page |
|--|------|
| CHAP. I.—GENERAL PRINCIPLES. Cleanliness—Durability—Economy—Fitness—Wood casings—Five classes of sanitary fittings | 357 |
| CHAP. II.—BATHS. Materials used—Wood cradling and casing—Roman baths—Metal “safes”—Shapes of baths—Lengths—Surface-finishing—Porcelain-enamelled iron baths—Copper, stamped steel, and zinc baths—Slate—Fire-clay or “porcelain”—Marble—Concrete—Wood—Wooden baths lined with lead—Bad forms of outlet—Combined waste-and-overflow arrangements—Waste-pipes and utilization for flushing drains—Baths fitted with douche, spray, shower, &c.—Cottage baths—Gas-heated baths—Turkish baths—Hot-air baths | 359 |
| CHAP. III.—LAVATORIES. Faulty lavatory-basins—Materials—“Corbel” lavatory-basins—Porcelain—Outlets, good and bad—Combined waste-and-overflow arrangements—Tip-up basins—Wooden casings | 370 |
| CHAP. IV.—SINKS. Materials: stone, slate, glazed earthenware, enamelled fire-clay, porcelain-enamelled cast-iron, wood lined with lead, tinned copper—Description of sinks required—(1) For washing vegetables; (2) For washing copper and iron cooking utensils; (3) For washing crockery, glass, and silver—Slate sinks—Nursery sinks—Overflows and wastes—Grates and strainers—Slop sinks—Lish’s combined water-closet, urinal, sink, douche-bath, lavatory, &c. | 375 |
| CHAP. V.—WATER-CLOSETS. History of water-closets—Bramah’s valve-closet—Pan-closets—D-traps—Modern valve-closets—Plug or plunger closets—Trapless closets—Tumbler or tipper closets—Trough closets—Hopper closets—Wash-out and wash-down closets—Wash-down pedestal closets—Corbel and bracket closets—Combined water-closets and slop-sinks—Syphonic-action closets—Seats and casings—London County Council’s joint between earthenware closet and lead branch of soil-pipe—Metallo-k ceramic joint—Joint with clips and screws—Flange joints—Screwed connections—Hellyer’s and Humpherson’s joints—Syphonage of traps—Anti-D traps—Flushing rims, &c.—Quantity of water required for flushing—Water-waste preventers—Syphon cisterns—Other cisterns—Portable water-closets—Automatic flushing apparatus | 381 |

| | |
|--|-----|
| CHAP. VI.—URINALS. Urine—Use of pedestal wash-down closets as urinals—Ranges of urinals—Hexagonal group of urinals | 399 |
|--|-----|

SECTION VIII.—DRAINAGE.

BY WILLIAM SPINKS, A.M. INST. C.E., M.SAN. I., &c.

| | |
|---|-----|
| CHAP. I.—GENERAL DESIGN. Dangers of bad drainage—Sewage-conduits—Amount of sewage—Separation of sewage from rainfall—Extremes of rainfall—Dangers and defects to be avoided—Decomposition of sewage—Stone and brick drains—Egg-shaped earthenware pipes—Circular socketed earthenware pipes—Drains inside houses—Connection of rain-water pipes with drains—Necessity of immediate removal of sewage—Twenty essential conditions of good drainage—Definition of "Drain" and "Sewer"—Practical difficulties of combined drainage—The design of a system of drainage | 405 |
| CHAP. II.—THE SIZE AND CAPACITY OF DRAINS. Drains usually too large—Hourly flow of sewage—Hourly rainfall—Self-cleansing velocities—Hydraulic mean depth—Maguire's decimal rule for gradients—Eytelwein's and Chezy's formulas for calculating velocity of flow in drains—Santo Crimp's formula—Carrying capacity of drains of various sizes—Formula for calculating discharge from drains with various depths of flow | 416 |
| CHAP. III.—DRAIN-PIPES. Strength of drain-pipes—Durability—Imperviousness—Smoothness—Earthenware drain-pipes (stoneware and fire-clay)—Cast-iron pipes—Glass-enamelled iron pipes—Joints in iron pipes—Egg-shaped pipes—Plummer's drain-pipe—Necessity for sound joints in drains—Materials used for jointing: clay, limes, cements, &c.—Methods of making joints—Drain-badgers—Joints of gasket and cement—The "Loco" self-centring joint—Types of special joints—Stanford's—Doulton's—Hassall's—Button's—Green's—Ames and Crosta's—Wakefield's—Sykes's—Encasing drains in concrete—Advantages of cast-iron drain-pipes | 424 |
| CHAP. IV.—VENTILATION, DISCONNECTION, AND INSPECTION. Disconnection of house-drains from sewers—Ventilation of drains—Methods shown in the Model By-laws—Area of ventilating pipes and shafts—Air-inlet covers and shafts—Disconnecting chambers—Extract pipes—Ventilation by rain-water pipes condemned—Objections to bends—Cast-iron ventilating pipes—Cows—Construction of manholes—Manhole-bottoms—Uses of manholes for bends and changes of level—Channel-bends and junctions—Drain-stoppers—Walls of manholes—Step-irons—Stone covers—Cast-iron manhole-covers—Air-tight covers—Lamp-holes | 441 |
| CHAP. V.—THE TRAPPING OF DRAIN-INLETS. Every inlet (except those for ventilation) to be trapped—Traps for rain-water pipes—Drain-inlets within buildings—Passage of sewer-gases through traps—Disconnection of cellar-drains by areas and air-shafts—Subsoil-drains—Flap-valves—Couzens's gully-trap for preventing back-water—Dyer's valve—Couzens's ball-trap interceptor—Adams's sewage-lift—Traps between soil-pipes and drains—Independent ventilating shafts then necessary—Syphon-traps—Precautions in using traps—Buchan intercepting trap—"Cerus" trap—Oates and Green's trap—Stidder's drop trap—Winer's "Detector" trap—Slagg's trap—"Loco" trap and bend—"Beacliff" intercepting trap for manhole—"Kenon" intercepting trap—Jones's stopper for the clearing-arms of traps— | |

| | Page |
|---|------|
| “Waverley” and Sykes’s closed intercepting traps—Traps for feet of soil-pipes— Disconnection of waste-pipes—Passage of sewer-gas through lavatory-basin traps— Six points about gullies—Channels for waste-pipes—Sykes’s slipper for waste-pipes —Grease-traps—Self-cleansing grease-gullies—Grease-traps with flushing apparatus | 453 |
| CHAP. VI.—CONSTRUCTION OF DRAINS. Ground plan of the premises—Intelligent workmanship and supervision necessary—Levels and sections—Depth of drains— Spirit-level and straight-edge—Boning-rod and sight-rails—Setting the sight-rails— Right to connect drains with sewers—Making junctions with pipe sewers by means of saddles, Doulton’s junction-pipe, and Oates and Green’s access-pipe—Connections with brick sewers—Excavation and tunnelling—Water in trenches—Timbering trenches—Preparations for laying the pipes—Testing the pipes before covering— Refilling trenches—Drains under buildings—Embedding pipes in concrete— Ventilation - - - - - | 477 |
| CHAP. VII.—FLUSHING, CLEANSING, AND TESTING DRAINS. Necessity for flushing drains—Field’s self-acting flushing cisterns—Adams’s flushing syphon— Merrill’s flushing syphon—Field’s flush-tanks—Adams’s glazed-ware syphon— Duckett’s tipper—Field’s flushing syphon in brick tank—The Miller syphon— Penstocks—Drain-clearing tools—Water-pressure the best test—Jones’s apparatus —Drain-stoppers—Periodical inspection of drains necessary—Plans of drains— Warranty as to condition of drains - - - - - | 490 |

ILLUSTRATIONS.

DIVISIONAL-VOL. III.

| | Page |
|--|------|
| Plate XI. KEYHOLE-SHAPED BATH, FITTED WITH SHOWER, DOUCHE, SPRAY, AND WAVE ARRANGEMENTS, &c. - - - - - | 367 |
| „ XII. LISH'S COMBINED WATER-CLOSET, URINAL, SINK, DOUCHE-BATH, LAVATORY, &c. - - - | 380 |
| „ XIII. HELLYER'S "CORBEL" AND "BRACKET" WATER-CLOSETS - - - - - | 392 |
| „ XIV. DRAINAGE SYSTEM FOR A PAIR OF SEMI-DETACHED HOUSES - - - - - | 414 |

LIST OF ILLUSTRATIONS IN TEXT.

| <i>SECTION VII.</i> | | Page | Page |
|---|-----|--|------|
| Fig. | | | Fig. |
| 256.—Zinc Baths of various Shapes and Sizes - | 362 | 271.—Shanks's "Modern" Lavatory, with easily accessible Pull-up Waste and Overflow | 374 |
| 257.—Bad Form of Bath-supply and Waste - | 364 | 272.—"Tip-up" Basin, with Receiver and Trap, &c. - - - - - | 374 |
| 258.—" " " " - | 364 | 273.—Salt-glazed Earthenware Sink, - | 375 |
| 259.—" " " " - | 364 | 274.—Cream-glazed " " - | 375 |
| 260.—Combined Waste-and-Overflow Arrangement for Bath - - - - - | 365 | 275.—Wood Sink for Washing Crockery - | 376 |
| 261.—Bath-overflow discharging on to the Lead Safe - - - - - | 365 | 276.—Galvanized-iron Sink for Washing Metal Utensils - - - - - | 377 |
| 262.—Combined Waste-and-Overflow outside Bath - - - - - | 366 | 277.—Wood Sink for Washing Silver, &c. - | 378 |
| 263.—Bath-waste with Ball Plug and separate Overflow-pipe - - - - - | 366 | 278.—Plug-waste and Overflow from Wood Sink - - - - - | 378 |
| 264.—Section and Plan of Combined Waste-and-Overflow inside Bath - - - - - | 367 | 279.—Cast-iron Kitchen Sink - - - - - | 379 |
| 265.—Plan of Turkish Bath at Avery Hill - | 369 | 280.—Section of Glazed Fire-clay Sink, showing Waste and Overflow - - - - - | 379 |
| 266.—Bad Arrangement of Waste from Lavatory Basin—small plug Outlet and large Trap - - - - - | 370 | 281.—Plan and Section of tinned copper Strainer and Standing Waste - - - | 379 |
| 267.—Hellyer's Fire-clay "Corbel" Lavatory Basin, with "Downright" Overflow - | 371 | 282.—Section through glazed-ware Slop-sink, with Flushing-rim and Grid - - - | 380 |
| 268.—Whiteware Lavatory Basin, Top, and Skirting, in one piece, with "Downright" Overflow and "Quick-discharging" Waste-valve - - - - - | 372 | 283.—Section of an Eighteenth-century Water-closet - - - - - | 382 |
| 269.—Section of Lavatory Basin showing Waste-valve, Overflow-pipe from Basin to Trap, and Supply-inlet without visible Taps | 373 | 284.—View of Bramah's Water-closet - - - | 383 |
| 270.—Section of Lavatory Basin showing combined Waste and Overflow, and Water-supply through Waste-outlet - - - | 373 | 285.—Section of Pan-closet - - - - - | 383 |
| | | 286.—Section of D-trap - - - - - | 384 |
| | | 287.—Section of Hellyer's "Optimus" Valve-closet and Slop-closet - - - - - | 385 |
| | | 288.—Section of the Twin-basin Closet - - - | 386 |
| | | 289.—Plan and Section of Duckett's Automatic Slop-water Closet - - - - - | 387 |
| | | 290.—Section of Oates and Green's "Skroy" Waste-water Closet - - - - - | 388 |

| Fig. | | Page | Fig. | | Page |
|----------------------|--|------|------|--|------|
| 291. | Section of Trough-closet with Automatic Flushing Tank | 389 | 323. | Hassall's Double-lined Drain-pipe Joint | 436 |
| 292. | Section of Wash-out Closet | 390 | 324. | Button's "Secure" Joint | 437 |
| 293. | Wash-down Pedestal Closet | 391 | 325. | Green's "Truinvert" Drain-pipe Joint | 438 |
| 294. | Elevation of the "Kenon" Pedestal Wash-down Closet | 391 | 326. | Ames & Crosta's Single-seal Drain-pipe Joint | 438 |
| 295. | Jennings and Morley's Syphonic Water-closet | 393 | 327. | Ames & Crosta's Double-seal Drain-pipe Joint | 439 |
| 296. | Joint between Earthenware Outgo of Closet and Lead Branch of Soil-pipe, as required by the London County Council | 394 | 328. | Wakefield's Drain-pipe Joint | 439 |
| 297. | Doulton's "Metallo-kera-mic" Joint between Earthenware and Lead | 394 | 329. | Sykes's Patent Drain-pipe Joint | 440 |
| 298. | Flange-joint between Earthenware and Lead, with Clips and Screws | 394 | 330. | Section showing Drain-ventilation with Outlet at Head of Drain | 443 |
| 299. | Flange-joint screwed to Floor | 395 | 331. | Section showing Drain-ventilation with Inlet at Head of Drain | 443 |
| 300. | Freeman's Screw Connection between Earthenware and Lead | 395 | 332. | Cregeen's Air-inlet Cover | 444 |
| 301. | Hellyer's Joint with Brass Thimble and Elastic Cement | 396 | 333. | Ham Baker & Co.'s Air-inlet Cover | 444 |
| 302. | Humpherson's Joint | 396 | 334. | Air-inlet to Drain fixed to Wall | 445 |
| 303. | Section of Anti-D Trap | 396 | 335. | Section of Intercepting Chamber with Air-inlet Cover | 446 |
| 304. | Bean's Direct-acting Valveless Waste-preventer | 398 | 336. | Manhole for Towns where only small space is allowed | 446 |
| 305. | View of Urinal with Three Basins, Flushing Cistern, Floor-channel, &c. | 400 | 337. | Comparative Areas of Circles | 447 |
| 306. | Plan and Section of a Group of Six Urinal-basins | 401 | 338. | "Loco" Rust-chamber at Foot of Ventilation-pipe | 447 |
| <i>SECTION VIII.</i> | | | | | |
| 307. | Diagram illustrating the terms "Sewer" and "Drain" | 413 | 339. | Vertical Sections of Deep Manhole | 448 |
| 308. | Drainage for a Block of Four Houses | 414 | 340. | Section and Plan of Shallow Manhole | 448 |
| 309. | Section of Drain illustrating the "Hydraulic Mean Depth" | 418 | 341. | Border's Glazed Fire-clay Manhole Bottom | 449 |
| 310. | Data for Calculating Flow in Circular Sewers | 421 | 342. | Curved Glazed Fire-clay Channels for Manholes | 449 |
| 311. | Diagram to illustrate Trigonometrical Calculation of the Discharge from a Circular Drain | 423 | 343. | Winser's Channel-bends | 450 |
| 312. | Diagram to illustrate Arithmetical Calculation of the Discharge from a Circular Drain | 423 | 344. | Wyvurst | 450 |
| 313. | Joint in Cast-iron Drain-pipes | 428 | 345. | Doulton's Clip for holding Stopper in End of Drain | 451 |
| 314. | Elevation and View of Socket-end of Plumber's Drain-pipe | 429 | 346. | Adams's Air-tight Manhole-cover | 451 |
| 315. | Faulty Drain-pipe Joint—Bad Alignment | 431 | 347. | " " " " to receive Concrete Filling | 452 |
| 316. | " " Ridge of Cement | 432 | 348. | Section of Jones's Air-tight Double-seal Manhole-cover | 452 |
| 317. | The "Loco" Drain-badger | 432 | 349. | Plans and Section of "Tron" Inspection-eye for Bend | 452 |
| 318. | Drain-pipe Joint made with Gasket and Cement | 433 | 350. | Plan of "Tron" Inspection-eye for Four-way Junction | 453 |
| 319. | The "Loco" Self-centring Joint | 433 | 351. | Cliff's Rain-water Intercepting Gully | 454 |
| 320. | Stanford's Drain-pipe Joint | 434 | 352. | Hellyer's Rain-water Shoe | 454 |
| 321. | Doulton's Self-adjusting Drain-pipe Joint | 434 | 353. | Spinks's Cast-iron Rain-water Disconnecting Gully | 454 |
| 322. | Hassall's Single-lined " " | 435 | 354. | Bad Arrangement of Cellar-drainage | 455 |
| | | | 355. | Plan and Section of Area, &c., for Cellar Drainage | 455 |
| | | | 356. | Disconnection of Cellar-drain by Trap and Air-shaft | 456 |
| | | | 357. | Swing Flap-valve | 457 |
| | | | 358. | Balance " " | 457 |
| | | | 359. | Section of Couzens's Gully-trap with Copper Ball | 457 |
| | | | 360. | Section of Couzens's Gully-trap with weighted Door or Valve | 457 |

| Fig. | Page | Fig. | Page |
|---|------|---|-------|
| 361.—Dyer's Valve for preventing Back-water | 458 | 393.—Winser's Flushing-rim Grease-gully | - 476 |
| 362.—Section of Couzens's Ball-trap Interceptor for preventing Back-water - - - | 458 | 394.— " " " " with Raising Piece - - - - - | 476 |
| 363.—Adams's Automatic Sewage-lift - - - | 459 | 395.—Shoe for Boning-rod - - - - - | 480 |
| 364.—Section of Syphon-trap - - - - - | 462 | 396.—Sight-rail for Laying Drains - - - | 480 |
| 365.—Syphon-trap with Hand-hole - - - | 462 | 397.—Method of Setting up Sight-rails - - | 481 |
| 366.—Section of the Buchan Intercepting Trap | 463 | 398.—Section and Plan of Saddle-junction for Branch-drain - - - - - | 483 |
| 367.— " " " " " " " " | 463 | 399.—Doulton's Patent Junction-pipe - - | 483 |
| 368.—Section of Oates & Green's Intercepting Trap - - - - - | 464 | 400.—Oates & Green's Patent Socketless Access- pipe - - - - - | 484 |
| 369.—Section of Stidder's Drop Trap - - - | 464 | 401.—Codling's Patent Rest-bend Junction - | 484 |
| 370.— " Winser's Villa "Detector" Trap | 464 | 402.—Junctions for Brick Sewer - - - - | 485 |
| 371.—Slagg's Intercepting Trap - - - - - | 465 | 403.—Method of Timbering Trench - - - - | 486 |
| 372.—Section of "Loco" Intercepting Trap - | 465 | 404.—Concrete Cradle for Pipes - - - - | 487 |
| 373.—Section showing Change of Level by means of "Loco" Trap and Bend - - - | 465 | 405.—Section of Field's Annular Syphon - | 490 |
| 374.—Section of "Beacliff" Intercepting Trap for Manhole - - - - - | 465 | 406.— " Adams's Flushing Syphon - - - | 491 |
| 375.—Improved "Kenon" Intercepting Trap - | 466 | 407.—Section of Merrill's Patent Flushing Syphon with Tipping Bucket - - - | 492 |
| 376.—Jones's Patent Stopper for the Clearing- arms of Intercepting Traps - - - - - | 466 | 408.—Section of Field's Self-acting Flush-tank | 493 |
| 377.—"Waverley" Closed Intercepting Trap fixed in Manhole - - - - - | 467 | 409.—Section and End Elevation of Field's Stoneware Flush-tank - - - - - | 493 |
| 378.—Section of Sykes's Interceptor in Manhole | 468 | 410.—Adams's Glazed-ware Flush-tank, for use with Waste Water - - - - - | 494 |
| 379.—Two Forms of Trap for Foot of Soil-pipe | 468 | 411.—Duckett's Tipper used for Flushing Drains - - - - - | 494 |
| 380.—Green's Soil-pipe Interceptor - - - - | 469 | 412.—Field's Automatic Flushing Syphon in Brick Tank - - - - - | 495 |
| 381.—Docking's Channel for Waste-pipes - | 470 | 413.—Miller Syphon in Manhole, - - - - | 496 |
| 382.—"Loco" " " " " " " " " | 470 | 414.—Screw-down Penstock - - - - - | 497 |
| 383.—Sykes's Slipper, &c., " " " " | 471 | 415.—Disc Penstock - - - - - | 498 |
| 384.—"Loco" Grease-trap with Retainer - | 472 | 416.—Drain Shoot for use with Penstock - | 498 |
| 385.—Grease-trap for Moderate-sized House | 472 | 417.—Drain-clearing Tools - - - - - | 499 |
| 386.—Adams's Grease-trap - - - - - | 472 | 418.—Jones's Apparatus for Testing Drains with Water - - - - - | 500 |
| 387.—Hellyer's Stoneware Grease-gully for large Houses, &c. - - - - - | 473 | 419.—Jones's Bag Pipe-stopper - - - - | 500 |
| 388.—"Eclipse" Grease-trap - - - - - | 473 | 420.— " Screw Expanding Pipe-stopper - | 501 |
| 389.—Bolding's "Simplex" Grease-trap - - | 473 | 421.—Syer's "Grip" Plug - - - - - | 501 |
| 390.—Le Rossignol's Self-cleansing Grease- gully - - - - - | 474 | 422.—"Addison" Drain-stopper - - - - | 501 |
| 391.—Hellyer's Flushing Grease-trap - - - | 475 | 423.—Price's "Combination" Drain-testing Block - - - - - | 502 |
| 392.—Bowes-Scott & Western's Automatic Flushing Grease-trap - - - - - | 476 | | |

SECTION VII.

SANITARY FITTINGS

BY

KEITH D. YOUNG

FELLOW OF THE ROYAL INSTITUTE OF BRITISH ARCHITECTS



SECTION VII.—SANITARY FITTINGS.

CHAPTER I.

GENERAL PRINCIPLES.

In choosing the sanitary fittings for a dwelling-house, certain main principles, applicable to all classes of fittings alike, should be carefully kept in view. Of these, **cleanliness** must naturally hold the first place. Every fitting, whatever its use, should be of such a material that it can readily be cleansed, of such a colour that the presence of dirt can easily be detected, and of a form that gives the least possible facility for the lodgment of dirt. In some fittings—as water-closets and urinals—it is necessary to provide not only for efficient cleansing, but also that the process of cleansing shall be effected with due regard to economy of water.

Durability is obviously an important quality in all fittings; but especially in those which, like the flushing apparatus of water-closets, are subjected to continual and often careless usage, and upon the efficient working of which the health-conditions of a house largely depend. To be really efficient, a fitting should be durable in all its parts, and all mechanism should therefore be as good and as simple as it can be made, consistently with the work it has to do. The evils of cheap jerry-made mechanism are well exemplified in the low-priced kinds of flushing-cisterns, which are made to comply with water-companies' requirements at the least possible cost. In no kind of fitting is it so necessary to have the best materials and workmanship; but in no kind is such a combination less frequently found.

Economy is a factor that cannot and should not be disregarded, but it must be combined with durability and efficiency, or it ceases to be in the true sense of the word economy. To be low-priced is not by any means always or necessarily to be cheap; more frequently, indeed, it means in the long run wasteful expense.

In the design of every fitting, due thought should be given to the **fitness**

of the material and form, to the work it has to do. Many fittings appear to be designed with complete disregard to the use to which they have to be put. Water-closets and lavatory-basins, whose inner surfaces are covered with printed ornament instead of being spotlessly white, are examples in point. The unintelligent arrangements for overflow outlets to lavatory-basins and baths, and the happily-exploded fashion of admitting clean water to baths and lavatories by the same inlet that served for the egress of dirty water, are obvious examples of defect in design. These and other points will be dealt with in their proper place.

Lastly, the common practice of **boxing up the spaces** around water-closet apparatus and baths, and under lavatory-basins and sinks, is for the most part to be strongly deprecated. In certain cases properly-arranged casings are desirable and perhaps almost indispensable: a well-made enclosure under a lavatory-basin hides the plumber's work, and deadens the sound of the water, while at the same time it presents a neat and even ornamental appearance that is not without value; but such enclosures should not be used as cupboards for the reception of anything and everything it may be convenient to hide in them.

So also with baths and water-closet apparatus, the casing is of value as helping to deaden the sound resulting from the use of the fitting; but if allowed, it should be carefully safeguarded against becoming a receptacle for rubbish and filth. The arguments in favour of casing lavatory-basins, baths, and water-closets, do not apply to sinks; the spaces under sinks of all kinds should invariably be left open for inspection and easy cleansing.

The sanitary fittings appropriate for dwellings of various kinds may be divided into five classes, viz.:—**baths, lavatories, sinks, water-closets, and urinals**. Of these, the sink only can be said to be an absolute necessity in every class of house from the palace to the smallest cottage or tenement-house. Baths can now be had for so small an outlay that there are few houses of rents as low as £30 a year and even less, which are not supplied with a bath fitted with hot and cold water. They can hardly yet be said to have reached the cottage, though in some kinds of cottages, such as those inhabited by miners, the bath is as necessary as the sink. Fixed lavatory-basins must be regarded more or less as luxuries, and as appliances for saving labour. Water-closets are necessities only in districts where a system of water-borne sewage compels their use, and urinals, so far from being necessities, are fittings to be used with caution, and to be avoided where possible.

CHAPTER II.

BATHS.

Baths are made of the following **materials**: copper, sheet-iron, cast-iron, steel, zinc, slate, fire-clay, marble, wood, and wood lined with lead.

Of the various kinds of metal used for baths, **copper** is undoubtedly the best and most durable, as also it is unquestionably the most expensive. A well-made copper bath will bear re-enamelling many times over, and when finally discarded, the metal will always fetch a fair value. An iron bath, on the other hand, when worn out, is worth little more than the cost of removing it.

Baths of **tinned sheet-iron, copper, or zinc**, are made in two ways; either they are made of thin sheets of metal, which require the support of a wooden framework or "cradling"; or they are made of sufficiently stout metal to stand alone without support. The latter are known in the trade as Roman baths, and, from the point of view of cleanliness, possess manifest advantages over the lighter and less expensive forms which require cradling.

A bath which requires the support of **cradling** must also be cased; that is, the exposed side or sides of the rough framework must be concealed by **wooden panelling**. The space thus inclosed under and around the bath is generally inaccessible for at least half its extent, and, as the framed inclosure and top are as a rule ill-fitting, becomes a harbour for dirt and rubbish of all descriptions. If a bath must be inclosed, and, as already explained, there are some advantages in doing this, the framing should be made of hardwood, as dust-proof as possible, and the top (also of hardwood) should be bedded on the top edge of the bath in hardwood.

Roman baths, on the other hand, need no casing, and if made (as they generally are) with a large roll on the top edge, do not require a wooden top. They can and should be fixed clear of the walls, so that access can be had to both sides for the purpose of cleaning. These baths can be had with the taps so arranged that they are entirely self-contained, and can, if need be, be fixed in the centre of a room.

Another advantage of the Roman type of bath is that the **metal tray** or "**safe**" underneath must be dispensed with, and accordingly the overflow has to be so arranged that the safe is not needed. The safe, it should be explained, is a metal tray about four inches deep, placed under a bath so that all water leaking from the bath, or overflowing the top of it, may be caught and carried away by the tray, and not escape on to the wooden floor and so through to a

ceiling below. These safes are apt to become extremely offensive from various causes. They are frequently laid flat, and not infrequently with a fall in the contrary direction to the outlet; with the result that, when water is suffered to overflow, it remains in the safe instead of running away. If the water is soapy—as of course it frequently is,—the dried soap will be left on the surface of the metal long after the water has evaporated, and the effect will be extremely unpleasant.

There is considerable variety in the **shape of baths**. They are either made to taper from head to foot, or are made parallel. They are made with sloping sides and head, or with perfectly straight sides and head; they are sometimes made partially covered over, or with a hood at the end for shower, douche, needle, and spray baths, or they are made with curved sides. The object of sloping the sides, so that the bottom of the bath is narrower than the top, and of tapering the bath from head to foot, is to economize water. This arrangement is sometimes carried to such an excess, that the bath is uncomfortably narrow at the bottom. The head is sloped to give a more comfortable rest for the back of the person using the bath, and the foot end of the bath is sometimes covered in order to assist in retaining the steam. The hood arrangement will be described hereafter.

A point of importance is the **formation of the angles** of the bath inside. The junction of the bottom with the sides and ends should be rounded, in order to afford as little lodgment as possible for grease and dirt. This can of course be very readily done in a cast-iron bath, but in sheet-iron or copper the formation of these rounded angles is not so easy. In the stamped steel baths the curved form is also easily obtained, and is one of the most favourable points about this kind of bath.

The usual lengths of baths are 5 feet, 5 feet 6 inches, and 6 feet, but smaller sizes are made for use in nurseries, and have the advantages of economizing water, and of being rapidly filled and emptied.

The finishing of the surface of a metal bath can be arranged in several ways. In best work, both copper and iron baths are first tinned and then japanned or enamelled. The object of the coat of tin is to prevent oxidation and to give a better ground for enamelling. In applying a coating of tin to iron, the surface of the iron is first cleaned by being turned to a bright polish in a lathe. This can only be done to comparatively small articles, and is impossible in the case of cast-iron baths, which are made in one piece. The tinning in the case of the latter kind of bath is done by a process of dipping, first into acid and then into tin. Tin thus applied does not stand nearly so well as when it is applied to a bright surface, the adhesion not being so perfect.

The process of japanning copper baths, and enamelling tinned sheet-iron baths, is identical. The surface of the metal is first carefully cleaned, and painted with a specially-prepared paint, the base of which is zinc. It is then subjected to a heat of about 300 degrees F. Before the next coat is applied, the bath is well rubbed down with pumice stone. It is then painted again and fired as before. There are usually three qualities of finish, the difference consisting in the number of coats of paint and firings applied; thus, "first quality" will usually mean a bath which has had four coats, "second quality" one which has had three coats, and "third quality" one which has had two coats.

Copper baths may also be finished with a planished surface, which looks bright and clean, but requires regular and frequent attention to keep it in proper condition.

Cast-iron baths can be finished with a **porcelain enamel**; and recent improvements in the preparation of the enamel warrant the hope, that this kind of finish will in future be of a more durable nature than it has hitherto been. The defect of all porcelain enamels on iron has been that the porcelain is brittle, and liable to be chipped off easily. If the iron be exposed, oxidation at once occurs, and the remainder of the surface is more or less spoilt. A method of applying the first coat has now been devised, which, it is claimed, gives a certain toughness to the enamel, by which ordinary chipping is almost if not quite prevented. The bath is first scrubbed with pumice stone and sand to a perfectly smooth surface. It is then heated to a red heat in an annealing furnace. This part of the process involves considerable risk to the bath, as, if unequal expansion takes place, the bath bursts. Though less than formerly, the proportion of failures from this cause is still about one in twelve. When the bath has passed successfully through the first firing, it is again cleaned and coated with flint-glass, sand, and borax; this is called the "grip". It is then put into the kiln again, after which it receives the final coat of glass, china-clay, and whatever colouring matter is required. This done, it is again fired, and should emerge from the kiln with a perfectly smooth porcelain face. The advantages of a porcelain enamel are that it is unaffected by any kind of acid, or by any of the salts (such as Tidman's bay-salt) that are frequently used in baths. The painted enamel is, on the other hand, acted upon very quickly by inferior soaps, and by the salts referred to.

A special kind of copper bath, made by the Sanitary Bath Company, is formed with very thin and fine sheet-copper in three pieces, for head, foot, and body respectively. The sheets are tinned and planished, and the seams are then brazed, and covered and supported outside with cast-iron bands. **Stamped steel**

baths are made in a very similar way, the seams being of course soldered together. Both these kinds of bath are light and serviceable, and are moderate in price. The only objection to them is that, the metal being so very thin, the expansion caused by the admission of water, and also by a person getting in, is evidenced by somewhat startling noises.

Zinc baths are very little used in England. They are extensively used in France, and are also somewhat in favour in Scotland. The surface is usually polished, and when new looks clean and bright. To be kept up to this condition, however, it requires constant scrubbing, and great care to prevent contact for

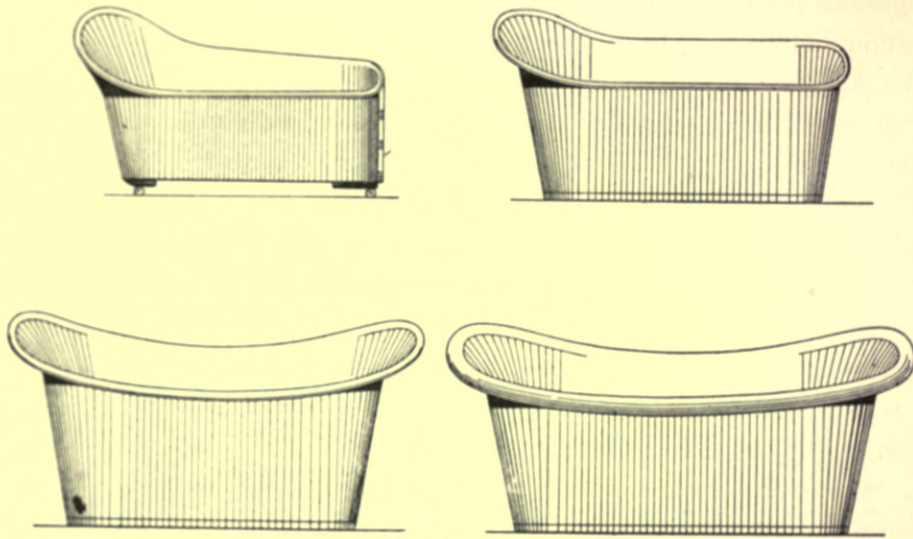

Fig. 256. - Four Zinc Baths.

any length of time with greasy water. The amount of time and labour required to keep a polished zinc bath in proper condition, would be an impossibility in the average English household, and a zinc bath ill-kept soon becomes both unsightly and unclean. Fig. 256 shows different forms of zinc baths made by a French firm.

Slate baths are made of slabs of slate about one inch in thickness, held together with iron bolts. The slabs can of course be enamelled either black or white, or to imitate marble; but the process is costly, and the result by no means satisfactory. There is, in fact, nothing to recommend the use of slate for this purpose, and very few baths are made of the material.

Fire-clay (or, as it is sometimes called, "**porcelain**") is now very largely used for baths. The material used is the well-known fire-clay from the Coal-measures. The clay is subjected to a process of weathering, grinding, tempering, and mixing with certain other ingredients, in which the greatest care is taken to obtain a

substance, which will burn and contract with regularity throughout its entire thickness. It is tempered or brought to the required degree of plasticity by the addition of water, and is then thoroughly stirred and kneaded in a pug-mill. The baths are built up by hand over a wooden block of the shape required, and dressed by hand, and when dry are burned in specially-constructed ovens. When they emerge, the baths are in what is called the "biscuit" state; they are then enamelled inside with a porcelain glaze, and are again burned. The process of burning in each stage occupies several days, and involves an appreciable percentage of risk from unequal expansion and contraction, and other causes. It will be seen, therefore, that the manufacture is necessarily a costly one on account of the number of failures that inevitably occur. The introduction of fire-clay baths is due to a suggestion of the late Prince Consort. In 1846 the Society of Arts, of which his Royal Highness was President, offered a prize for the production of a glazed porcelain bath made in one piece. After a long and costly series of experiments, Messrs. Rufford of Stourbridge produced, in 1850, a porcelain bath which fulfilled all the conditions laid down by the Society, and for which the "Isis" gold medal was at once awarded. The manufacture thus started was destined to increase very largely as time went on, and to-day glazed porcelain baths are in large request, more especially for hospitals, asylums, and other public institutions.

Fire-clay baths have two great drawbacks, their great weight, and their feeble power of retaining heat. The first has within the last few years been largely reduced,¹ but not without risk to the strength of the bath. The second is a physical property of the material, and cannot be altered. The great advantages of a porcelain bath are its durability, and the fact of being in one piece without seams or joints. The glaze is unaffected by acids or salts, and can only be injured by wilful mischief. The coldness of the material to the touch is, however, unquestionably a real defect, and one which may be, in some cases—as when a hot bath is quickly needed—positively injurious. It is unfortunate, too, that it is practically impossible to enamel a fire-clay bath outside as well as inside. If this could be done with reasonable safety, a fire-clay bath would be for all ordinary purposes perfect. The risk, however, of failure in the burning is too great, since it is impossible to ensure that no air is contained in the substance of the bath. If any air should be confined in the clay, the coating of enamel on both sides quite prevents its escape, and the result is of necessity a failure.

The uncertainty of the process, and the large proportion of the baths that come out of the kiln "all-buts", "seconds", and "thirds" (although each has

¹ Formerly a 5 ft. 6 in. bath weighed about 7 cwt., to-day a bath of the same size weighs only about 5½ cwt.

had the same amount of labour and care bestowed upon it as those which come out "best"), sufficiently account for the high prices which are asked for fire-clay baths.

Of marble baths there is not much need to speak at length. A solid bath

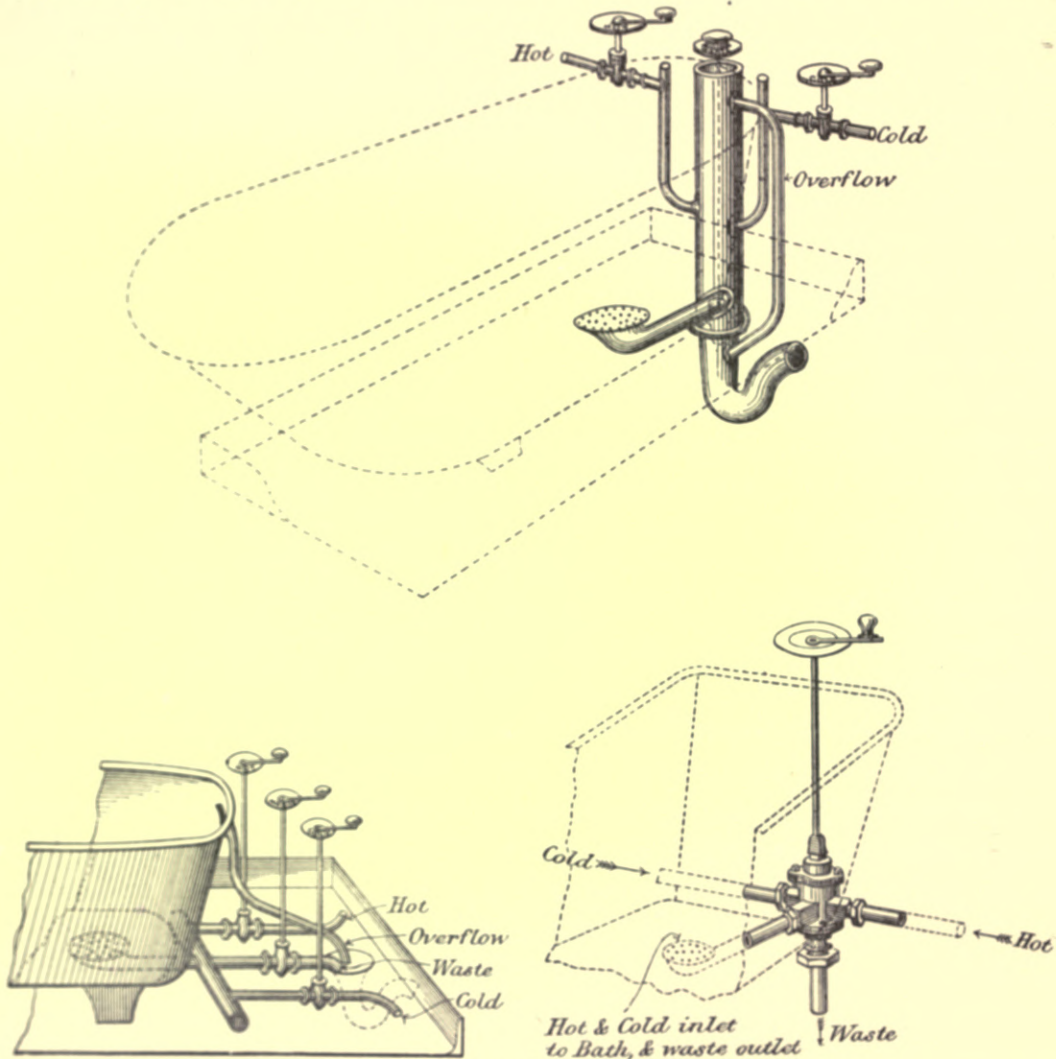

Figs. 257, 258, 259.—Three Bad Forms of Bath-supplies and Waste.

hewn out of one piece of marble is a luxury suitable only for the mansion or the palace. Baths are also sometimes made of slabs of marble put together with bolts in the same way as slate baths. In whichever way they are made, marble baths are subject to the same drawbacks with regard to temperature as the porcelain baths.

Concrete baths lined with a sort of rough marble mosaic were introduced

some years ago, but failed to command a profitable sale, and are not now in the market.

Wooden baths are used still in some parts of the country, but there is no special advantage in them, and, in point of price, they could not compete successfully with the cheaper forms of iron baths.

Wooden baths lined with sheet lead were much used, especially in Scotland,

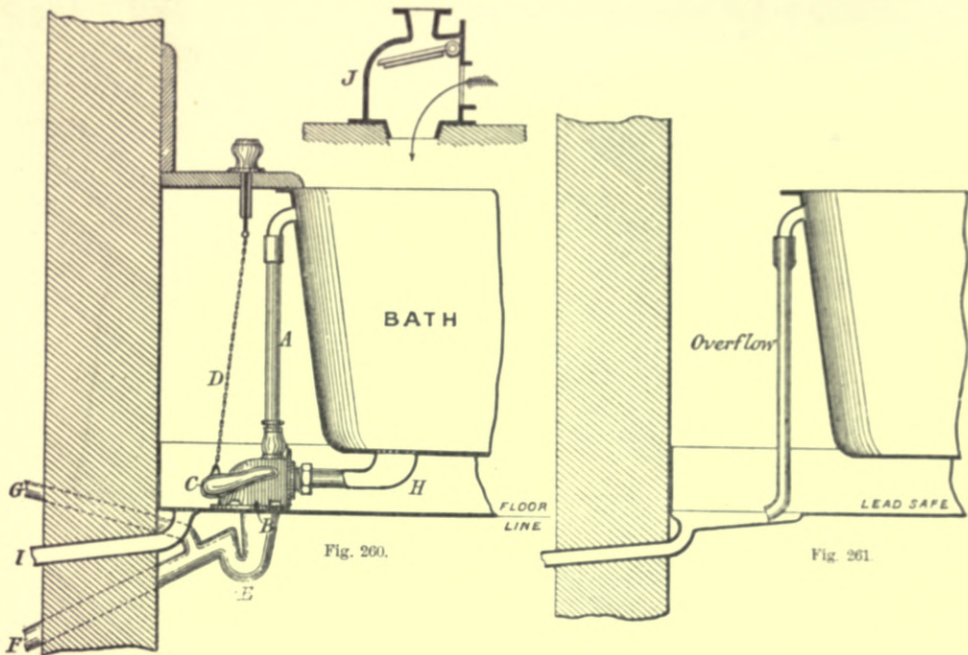

Fig. 260.—Combined Waste-and-Overflow Arrangement for Bath:—A, Overflow-pipe, fitted with Bayonet-catch, so that it can be easily removed for cleansing; B, "Quick-waste" Valve with Weight C, and Chain D; E, Lead Trap; F, Waste-pipe; G, Anti-siphonage Pipe from Trap; H, Lead Safe; I, Waste-pipe from Safe; J, Section showing the Waste-valve open, and conducting the Water past the Orifice of the Overflow-pipe.

Fig. 261.—Bath-overflow discharging on to the lead Safe.

before the introduction of cast-iron baths, and though such baths allow the safe to be dispensed with in certain cases, they are not so cleanly as the enamelled cast-iron or fire-clay baths, nor do they compare well in price either.

The methods adopted for **discharging the waste water from baths** vary considerably. The most simple of all is a plug and washer with or without a chain.

Of the **many bad forms** in common use until recent times, three are here given as typical examples, viz., figs. 257, 258, and 259. It will be noticed that, though the three examples differ in details, they have one feature in common, viz., the water, both hot and cold, is admitted to the bath, and the waste water discharged, through *one* orifice and along *one* length of pipe common to all. Anything more uncleanly than this arrangement could not possibly have been devised. Some of the dirty water from the last use of the bath almost

invariably remains in the horizontal length of pipe which is common to all three purposes, and this is of necessity forced back into the bath by the inrush of fresh water. Though still sometimes to be seen, this class of fitting may be regarded as obsolete; but it is curious that its disuse, in the first instance, was not due to any sense of its unfitness from a sanitary point of view, but on account of the waste of water which would be liable to occur undetected, if the waste were left open, and the supply-valves leaked. The waste-pipe of a bath ought to be entirely independent of the supply-pipes and inlets.

Fig. 260 shows a **combined waste-and-overflow arrangement**. The waste-outlet is shut by means of a flap, which is attached to a weighted handle. The flap is

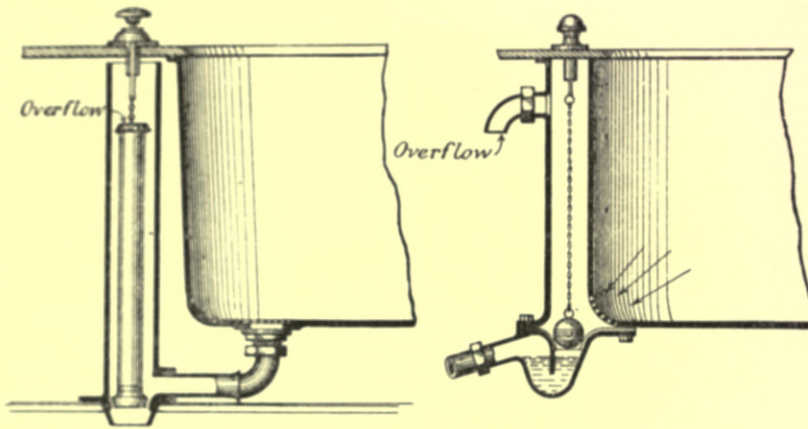
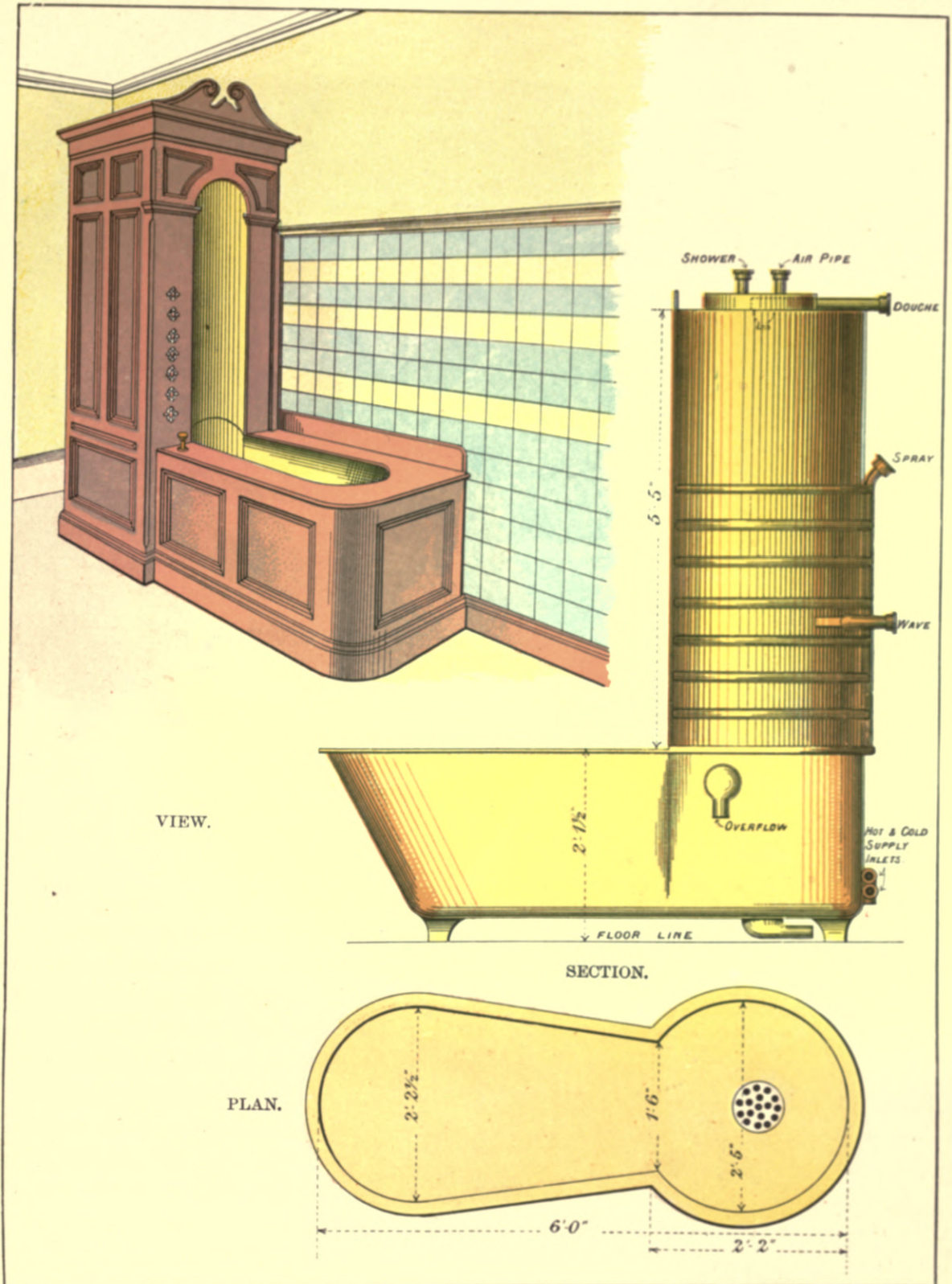

Fig. 262.—Combined Waste and Overflow outside Bath.

Fig. 263.—Bath-waste with Ball Plug and separate Overflow-pipe.

raised by a chain attached to the waste-knob, and when the latter is released after being raised, the weighted handle falls back and shuts the valve. When the waste-valve is closed, there is a free passage down the overflow-pipe. The vertical pipe is fitted with a bayonet-catch in order that it can be removed for cleansing, and the inside of the valve-box is lined with porcelain enamel. In this case the overflow discharges into the waste-pipe. An alternative arrangement is shown in fig. 261, where the overflow-pipe discharges over the outlet-pipe from the lead safe. Another form of combined waste and overflow is shown in fig. 262. In this arrangement, the overflow rises up the annular space between the standing waste-pipe and the pipe in which it is inclosed, and so into the waste-pipe. Fig. 263 shows a somewhat similar arrangement, but in this case there is no inner pipe, and the overflow escapes through an orifice at the upper part of the standing waste. All the foregoing overflow and waste pipes are outside the bath. Fig. 264 shows an arrangement of overflow inside the bath, the end of which is specially shaped to receive it.



KEYHOLE-SHAPED BATH, FITTED WITH SHOWER, DOUCHE, SPRAY, AND WAVE ARRANGEMENTS, &c.

There are, of course, many other forms of overflow and waste, in combination or separately; the examples given are intended to serve as typical examples, and not as being the only available apparatus of good design. **The chief points to be observed** are to prevent the overflow becoming in any way a conductor of foul air into the bath-room, and to avoid, as far as possible, all chance of accumulation of soap-suds or dirty water about the overflow-pipe and waste-outlet. The trap on the waste-pipe should be made as small as possible

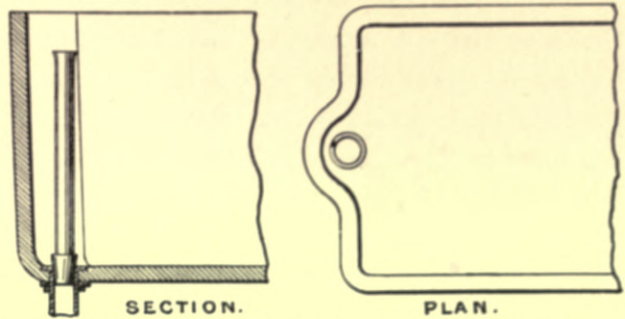

Fig. 264. —Section and Plan of Combined Waste and Overflow inside Bath.

consistently with quick discharge, in order to reduce the amount of stagnant water therein. Every part of the overflow arrangement should be easily and thoroughly cleansed.

The outlet (or "waste") pipe ought to be sufficiently large to discharge the contents of an ordinary bath (from 30 to 40 gallons) in about one minute and a half. For this purpose a pipe two inches in diameter is sufficient, provided the water-way is free and unobstructed. It frequently happens that the outlet is restricted by the grating in the bottom of the bath being made so as to give an area of free opening very much less than the area of the waste-pipe. The grating (if grating there must be) should be carefully designed, so that the area of the openings is rather more than that of the waste-pipe, in order to compensate for friction.

The question of waste-discharge leads naturally to the subject of **utilization of bath-wastes for drain-flushing**. Though this is a matter which somewhat overlaps the subject of drainage, it may, perhaps, be pointed out here that, while the discharge of 30 or 40 gallons of water in a body is undoubtedly of value in scouring out the drains, its value will necessarily be increased or diminished as the size and arrangement of the pipes are well or ill considered. For this reason the foregoing conditions about free water-way in outlet gratings, and waste-pipes of sufficient and regular diameter, must be carefully observed.

Hitherto reference has been made only to the ordinary bath of everyday household form. The more elaborate forms of baths provided with different apparatus for the application of **douche, spray, and shower** are of course expensive, and suitable only for the houses of the well-to-do. Plate XI. shows a bath of this kind. The hood at the head of the bath is perforated at several points, and

a system of pipes and valves supplies hot and cold water for shower-bath, wave, sitz, spray, and douche baths. These baths are usually made of first-quality enamelled copper, and are almost invariably cased with wood. They can be had at a much less cost, formed of cast-iron, enamelled inside and out, in which case the casing is not required. Less elaborate baths can be obtained with hoods, containing the necessary perforations, &c., for shower and spray. For shower-bath purposes only, an apparatus, consisting of a small circular cistern, with a curtain-rod fixed to the under side, and provided with a valve and cord for opening, can be applied to any ordinary bath at a comparatively small expense; or the cistern can be dispensed with, and the water led direct to a rose fixed to a bracket on the wall. In this case the curtain-rod will have to be fixed independently.

From the most expensive type of bath we pass to the cheapest. A bath of some sort is a very desirable thing in all cottages, and in miners' houses it is a necessity. **The cheapest form of bath** for a cottage is a cast-iron taper bath, enamelled inside, of the cheapest quality. Such a bath can be had for about £2, or even less, and the surface can be inexpensively renewed by the application of ordinary enamel paint. This bath would require to be filled by hand, as the price does not include taps or valves, and in any case the provision of a hot-water circulation system could hardly be made in a cottage. If the bath is placed in the scullery, cold water may be run into it from the tap over the sink by means of an india-rubber pipe and hose union. Where space is limited, the bath may be provided with a wooden cover (hinged or loose), which serves as a table when the bath is not in use. Occasionally baths are sunk in the floor, and covered with a trap-door; this arrangement saves space, but may render repairs more difficult.

Although not strictly speaking within the scope of this article, a few words may be said on the subject of **gas-heated baths**. In houses where there is no circulation of hot water from the kitchen boiler, and where gas is available, a "Geyser", or apparatus for heating bath-water by gas, is of great practical value. The chief precaution to be observed is that the products of combustion from the gas are carried off into the open air or into a flue, and that, if the supply of water fails or is cut off, the supply of gas is automatically shut off or reduced to a harmless quantity. In the "Lightning Geyser", patented by Messrs. Ewart & Son, both these conditions are fulfilled. The water enters the heating-chamber through a specially-contrived "dual" valve. When the water passes through this valve, it admits a full supply of gas to the burner; if from any cause the supply of water fails or is cut off, the supply of gas is instantly checked or shut off entirely. This Geyser is heated by a set of burners with ordinary

luminous flames, and the products of combustion are carried off by a flue at the top of the apparatus, which can be carried through the wall into the open air or into a flue, as may be desired.

It would be neither possible nor desirable in a work like the present to describe, with anything like fulness of detail, the principles and arrangements

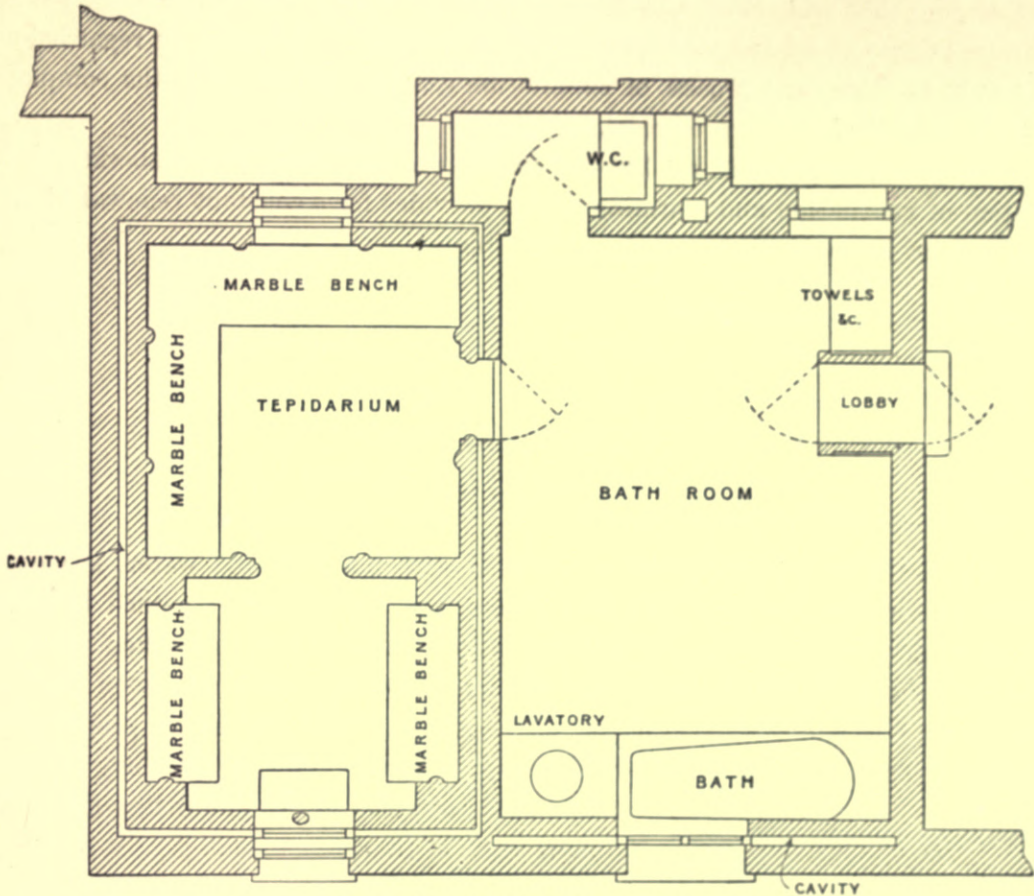

Fig. 265.—Plan of Turkish Bath at Avery Hill.

of Turkish baths; the subject, however, is one that should not be altogether ignored. Through the kindness of Mr. Thomas W. Cutler, F.R.I.B.A., we are enabled to give a plan of a private Turkish bath erected from his designs at Avery Hill, Eltham. The arrangement (fig. 265) consists of a bath-room and lavatory, answering to the "Lavatorium" of the Romans, a "Tepidarium", and a "Laconicum". The heat is supplied by hot-water coils and pipes, and ventilation is provided by means of shafts carried up through the roof, and communicating with the hollow space in the walls. This plan may be regarded as a sort of *via media* between the simplest form of hot-air bath, in which

the whole process is carried on in one room, and the most elaborate suite of Tepidarium, Calidarium, and Laconicum, with shampooing-room, lavatory, and Frigidarium.

A simple hot-air bath, in which all the essentials of the process can be practised, may be arranged in one room; all that is required being a floor, walls, and ceiling that will retain the heat, a stove for raising the temperature to the required degree, and suitable appliances for washing. This may be regarded as the unit, to which the process of subdivision can be applied, until the complete scheme described above is reached.

The essential point in all hot-air baths, whether simple or elaborate, is a system of ventilation and warming which provides for a constant renewal of the air, and for keeping the air as dry as possible.

CHAPTER III.

LAVATORIES.

A well-arranged lavatory basin, provided with hot and cold water, is a convenience which saves much time and labour, but the advantage gained in these respects may be more than counterbalanced if due care is not taken that all the details are clean and wholesome. A fixed lavatory basin may soon become extremely foul and offensive, if the waste-pipe and trap are not in proper proportion to each other, or if the overflow-pipe is badly arranged. Nothing is more foul than soapy water, and no fitting demands more care in its arrangement than a lavatory basin.

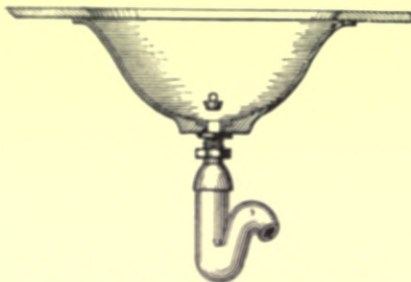

Fig. 206.—Bad Arrangement of Waste from Lavatory Basin—small plug Outlet and large Trap.

The ordinary lavatory basin is very faulty. The overflow is formed by a cluster of holes in the side of the basin, leading to a small pipe connected to the waste-pipe at some point below the basin. This overflow-pipe becomes clogged with soap, and, as it cannot be got at for cleaning, remains a perennial source of

nuisance and annoyance. The waste-hole in the bottom of the basin is frequently made so small that only a very small pipe can be fixed, and the connections are often so arranged that the diameter of the pipe is of necessity less than that of

the brass outgo. An outgo $\frac{1}{2}$ inch in diameter is not unfrequently connected to a trap of 2 inches diameter, as shown in fig. 266, the effect of which is that the trap becomes a sort of permanent reservoir of soapy water. The arrangements in lavatory tops (whether of marble or porcelain) for draining the soap dishes, are frequently of the most objectionable nature. A sinking is made on each side of the basin, from the bottom of which a hole is perforated through the marble or porcelain, and the outlet connected by a pipe to the waste-pipe or trap. The draining pipes to these sinkings speedily become choked, and in course of time very foul with decomposing soap.

The materials of which lavatory basins are generally made are porcelain, glazed fireclay or stoneware, and enamelled iron; they can of course be made of tinned copper and of galvanized iron, but neither of these materials is in common use. The essential difference between the arrangements neces-

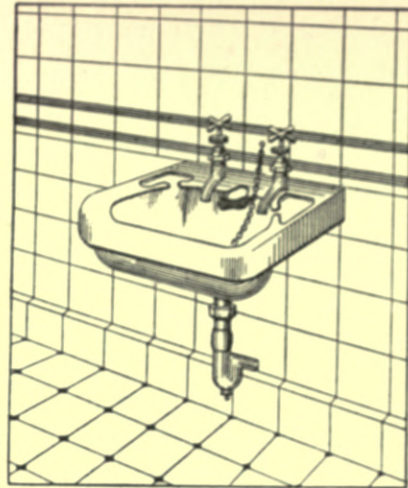

VIEW.

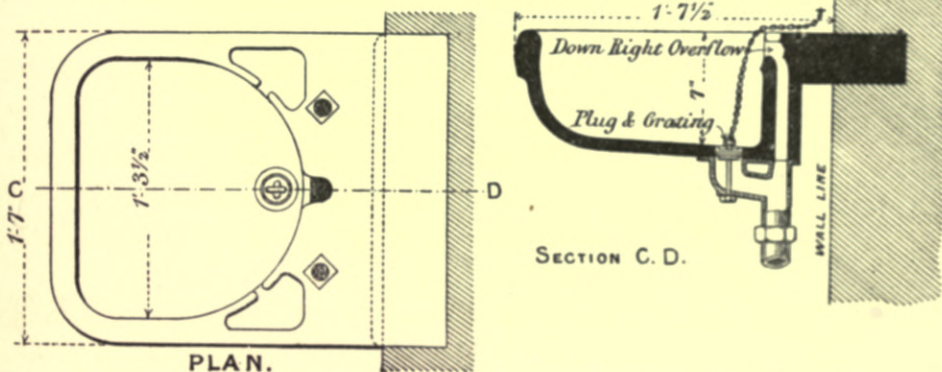

Fig. 267.—Hellyer's Fire-clay "Corbel" Lavatory Basin, with "Downright" Overflow.

sary for basins of any form of glazed earthenware and those made of enamelled iron, is that with the former it is possible to have the basin and top in one piece, while with the latter a separate top is indispensable.

The simplest and most satisfactory form of lavatory basin is one made of fire-clay, with a broad piece at the back for building into the wall (fig. 267). This basin was first made at the writer's suggestion for the Royal Eye Hospital, Southwark, by Messrs. Dent and Hellyer, and has since been largely adopted for

hospital work. It is, however, quite as suitable for domestic work, and is specially adapted for schools and places where ordinary whiteware basins would be liable to damage through rough usage. The basin is made in one piece of glazed fire-clay, white inside and tinted outside, and is of great strength; it requires no other support than the projecting piece which is built into the wall. The overflow and waste are separate, the back of the basin being recessed to receive the overflow; under the basin the overflow and waste are joined into one pipe. The sinkings for soap, &c., are drained by means of small channels sunk in the rim of the basin.

Fig. 268 shows a good form of porcelain lavatory basin, which can be fixed either with or without a wood casing. The basin and top are in one piece. The

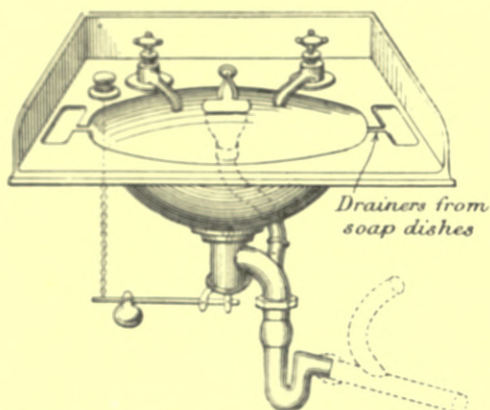

Fig. 268.—Whiteware Lavatory Basin, Top, and Skirting in one piece, with "Downright" Overflow and "Quick-discharging" Waste-valve.

overflow is the kind patented some years since by Mr. Hellyer, and is readily accessible for cleaning purposes. The lower end of the overflow is connected, not as is usually the case with the trap, but with the upper part of the waste-valve, in order to prevent anything washing back into the overflow-pipe. The sinkings for soap and brushes drain, as in the fitting previously described, into the basin by way of little slots sunk in the basin's rim. There are many ways in which lavatory basins of this kind may

be fitted up; marble tops are often required for the sake of appearance, though for sanitary reasons the porcelain basin and top in one piece is much to be preferred. The joint between the marble and the porcelain should be made with plaster of Paris, and not with oil putty, as the oil in the latter stains the marble.

The outlets of lavatory basins may either be closed with plug and chain, or they may be fitted with waste-valves, or they may have fixed plugs which cannot be removed. The plug and chain is unsatisfactory, as the chain, unless unusually strong, sooner or later gets broken or unshipped from its fastening, and the ordinary brass plug is apt to break the basin if carelessly used. An improvement on the brass plug is one made of india-rubber, but this is hardly applicable except in places where no mischievous boys are likely to have access. The valve arrangement is most suitable for high-class work, and is the neatest in point of appearance. The valve, as shown in fig. 269, is usually fixed at the

lower end of the waste-pipe, and is actuated by a weighted lever attached by a chain to a knob. By a simple arrangement of slots in the socket of the waste-knob, and bosses on the spindle of the knob, the latter can be fixed in position with the waste-valve open, so that it need not be held up all the time the basin is being emptied.

The fixed waste-plug is only suitable for places where valves would be inappropriate, and where anything in the shape of a loose plug and chain would be liable to be stolen. It involves putting the hand into the water to open it, an operation which ought to be performed by the

user of the basin; if this is not done, the system becomes somewhat of a nuisance.

A combined valve-waste and overflow is shown in fig. 270. The valve-plug is really a cylinder with its lower end shaped like an ordinary plug. When this rests on its seat, and water is turned into the basin, the water rises in the annular space surrounding the cylindrical plug, until it overflows the upper rim, and escapes down the plug into the trap and waste-pipe below.

The foregoing illustration shows an arrangement for admitting both hot and cold water through the waste-opening in the bottom of the basin. This is not an arrangement which can be recommended, as the water necessarily brings with it into the basin some of the soap and dirt which have adhered to the sides of the waste-pipe.

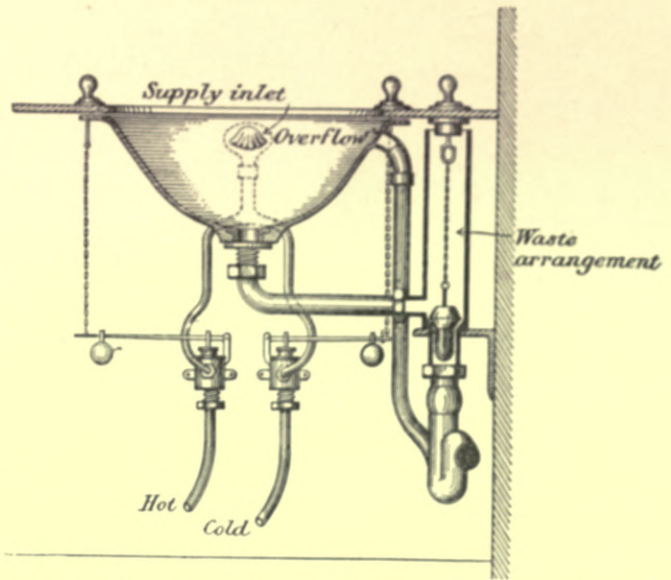

Fig. 269.—Section of Lavatory Basin, showing Waste-valve, Overflow-pipe from Basin to Trap, and Supply-inlet without visible Taps.

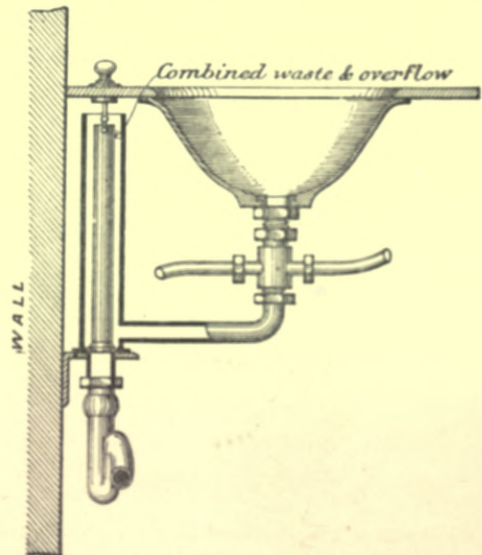

Fig. 270.—Section of Lavatory Basin, showing combined Waste and Overflow, and Water-supply through Waste-outlet.

A modification of the waste-valve and overflow has been recently devised, in which all the parts are easily accessible. This is effected by forming a

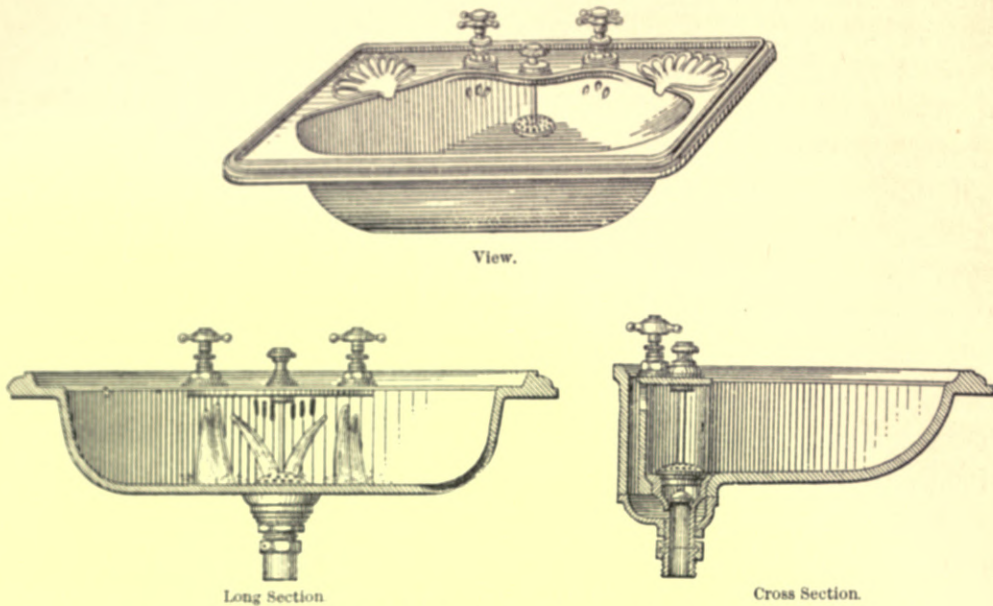

Fig. 271 — Shanks's "Modern" Lavatory, with easily accessible Pull-up Waste and Overflow.

vertical recess in the back of the basin for the valve, as shown in fig. 271, and by leaving the overflow-arm open at the top.

The tip-up basin (fig. 272) consists of two parts, the basin itself, which is

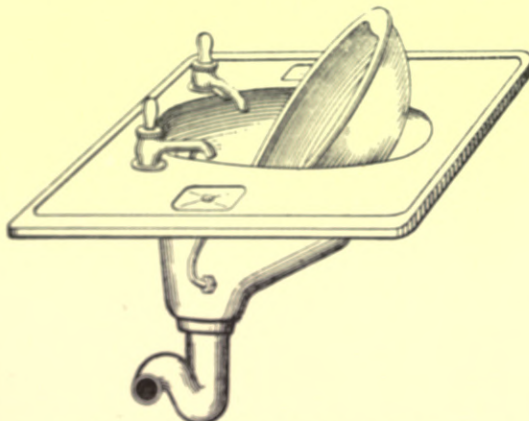

Fig. 272 — "Tip-up" Basin with Receiver and Trap, and with Drainers from Soap-dishes taken into the Receiver.

hung on pivots, and the receiver, into which the basin is emptied by being swung or tipped. The arrangement is convenient, inasmuch as the basin is easily and quickly emptied of its contents, and there is no valve to get out of order, or chain and plug to be lost. The objection to it is that the receiver, unless carefully and regularly cleaned, becomes extremely foul from the continual discharge of soapy water, which dries on the surface.

The basin, when released after being lifted, falls back into its place and impinges on a buffer of india-rubber. If this rubber buffer is mischievously abstracted (as is frequently the case when basins of this kind are fixed in boys' schools), the basin is broken. For these

reasons, the tip-up basin is only suitable for places where proper care is taken to keep it in good order. For public buildings, where there is a responsible person whose duty it is to see to the proper and systematic cleansing of the fittings, tip-up basins are most suitable and convenient; but it is questionable whether they are to be recommended for private houses.

Whether lavatory basins should or should not be provided with **wooden inclosures or casings**, is a question the answer to which depends mainly on the special circumstances in which they are placed. In all such places as schools and public buildings, hospitals, workhouses, and the like, the pipes and valves are far better exposed to view than hidden behind wooden casings, as the inclosed spaces speedily become receptacles for all sorts of abominations. In private houses, where appearance and the absence of noise are things to be considered, a neat and well-made casing may often be desirable. From a strictly sanitary point of view, however, the independent uncased basin with every part open to view, is much to be preferred.

CHAPTER IV.

SINKS.

Sinks are used for various purposes, and are made of several different **materials**. In small houses and cottages the one sink has to serve for all purposes. In it plates, dishes, and other crockery, vegetables, and the various vessels used in the process of cooking, must all be washed. For this purpose therefore a material that is at once strong, clean, non-absorbent, and inexpensive

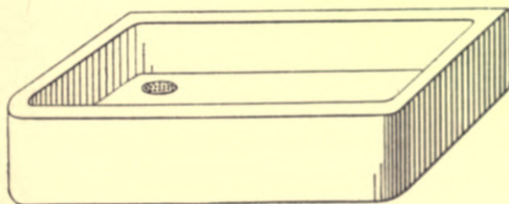

Fig. 273.—Salt-glazed Earthenware Sink.

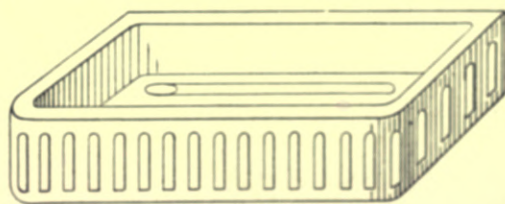

Fig. 274.—Cream-glazed Earthenware Sink.

is needed. **Stone** is strong enough, but it can scarcely be said to be either clean or non-absorbent, even in its hardest varieties. **Slate** fulfils all the first three requirements, but is expensive, and is, moreover, liable to crack with excess of heat. The best and cheapest form of sink that is at once strong and cleanly both in fact and in appearance, is one of **salt-glazed earthenware** (fig. 273). A cheap but slightly better kind of sink is made of **cream-glazed ware** (fig. 274).

The chief defect of these kinds of sinks is a tendency to wind or twist in the kiln, and unless care be taken in selection, the outlet may prove to be at the highest point of the sink.

A more expensive form of sink, but on the whole the most suitable for a house where only one scullery sink can be afforded, is that of **enamelled fire-clay or porcelain**. These sinks are made in the same way and of the same materials as the fire-clay baths, and if properly used are of great durability and very clean in appearance. They are frequently damaged by having heavy iron saucepans knocked against the sides or bottom, the enamel being chipped off. It is also a common complaint, that chinaware is liable to be broken when being washed in a porcelain sink. This sort of damage is little (if any) more liable to occur in a porcelain sink than a stone one, but the remedy in both cases is the same, viz., to wash the crockery in a wooden tub placed in the sink, and after washing to place the pieces on a wooden drainer.

Porcelain-enamelled cast-iron sinks are also used for scullery work, but are not equal to the fire-clay sinks. The enamel is much more easily damaged than that of the fire-clay sinks, and when once the iron is exposed, oxidation rapidly occurs, and the appearance and value of the sink quickly deteriorate.

Wood sinks lined with lead¹ (fig. 275) are commonly fixed in pantries and in housemaids' closets. The advantage of the lead is that, compared with iron,

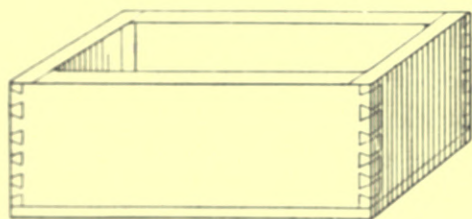

Fig. 275. — Wood Sink for Washing Crockery.

fire-clay, or stone, it is soft, and therefore fragile things, such as glass and china, are not so liable to be broken by contact with the sides or bottom of the sink. The chief disadvantage is that the lead is readily expanded and contracted by the application of hot and cold water, and the consequence is often a wrinkling

or corrugation of the bottom, which is objectionable. The remedy is to make the bottom of 10 or 12 lbs. lead, and the sides and ends of 8 lbs. lead. The bottom lead is lapped over the sides and ends, and the angles formed to a regular hollow with solder. The lead should be returned on the top edges of the sink and covered with a capping of oak fixed with brass cups and screws.

An alternative to the lead is **tinned copper**, but this is a harder and more expensive material.

For large houses where the number of sinks is not limited by considerations of expense, **separate sinks should be provided** (1) for washing vegetables; (2) for

¹ For the method of lining wood sinks with lead, see pp. 317 and 318, § VI.

cleaning copper and iron cooking utensils; (3) for washing crockery, glass, and silver. Sometimes sinks are required in nurseries, dairies, and for other special purposes.

1. **For washing vegetables** galvanized-iron sinks are generally considered the best. They should be from 18 to 20 inches deep, in order that green vegetables may float at the top of the water and the grit and dirt fall to the bottom. Such a sink is shown in fig. 276, with a galvanized-iron strainer and standing waste in one corner. Cast iron sinks may also be used for this purpose, either finished black, or galvanized, or porcelain-enamelled.

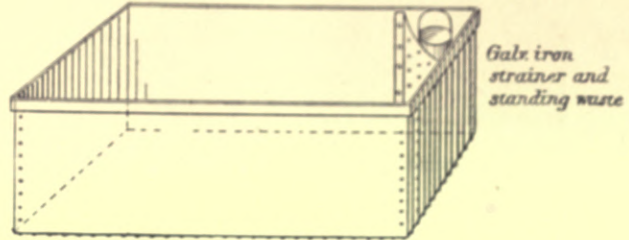

Fig. 276.—Galvanized-iron Sink for Washing Metal Utensils.

2. Galvanized-iron and cast-iron sinks are also suitable **for washing copper and iron cooking utensils**. Sinks for this purpose vary somewhat in size according to the amount of work to be done, but should be about 2 feet in depth, and the outlet of the waste-pipe should be kept 6 inches above the bottom of the sink, in order to prevent the sand used in scouring pots from being washed down into the drain. Iron sinks should always be flush riveted inside.

A word of caution is necessary with regard to the use of galvanized-iron sinks under certain circumstances. When the water is very soft (as it is, for example, in Glasgow, Sheffield, and Torquay), iron must not be used. The action of this class of water is to eat away the zinc and iron, and this at so rapid a rate that twelve months will often suffice to wear out the bottom. Under conditions such as these, the sinks for the purposes referred to above should be made of copper, or lined with it.

3. **For washing crockery, glass, and silver**, the best kind of sink is one made of wood; and the best kind of wood for the purpose is selected (or "picked") American birch, but pine, teak, and sycamore are also suitable. The sink is constructed, as shown in fig. 277, with wood 2 inches thick, held together by galvanized-iron bolts and nuts, the joints being tongued and grooved, and filled with a thin layer of red-lead and rushes. In very large establishments, it is convenient to have sinks for washing plates and dishes arranged in pairs, one being for washing, and the other for rinsing. These sinks should be about 2 feet 6 inches long, 1 foot 8 inches wide, and 1 foot 1 inch deep. For houses of more

moderate size, a depth of 11 inches is sufficient. For washing glass, the smaller class of crockery, and silver, a sink about 2 feet long, 1 foot 6 inches wide, and 9 inches deep is a convenient size.

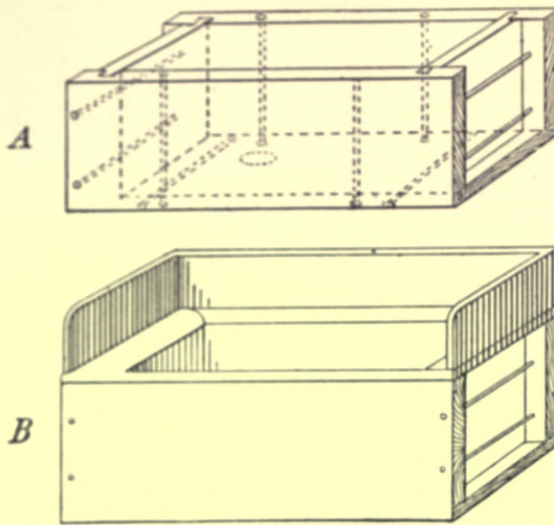

Fig. 277.—Wood Sink for Washing Silver, &c. A, the Framework; B, the completed Sink.

Slate sinks are useful for steeping salt meat and for pickling hams, but are not to be recommended for washing-up purposes on account of their liability to split with hot water, and their tendency to leak unless supported on solid brick piers.

The **glazed fire-clay sinks** already referred to are most appropriate for larder and dairy use, and for cooks' sinks.

Nursery sinks are best made of white enamelled porcelain ware. They should be about 2 feet long,

1 foot 2 inches wide, and 6 inches deep, inside measurement.

All sinks, except the shallower kinds for scullery use, and the cheaper kinds of stoneware, should be so fitted up that they can be filled with water, and it is

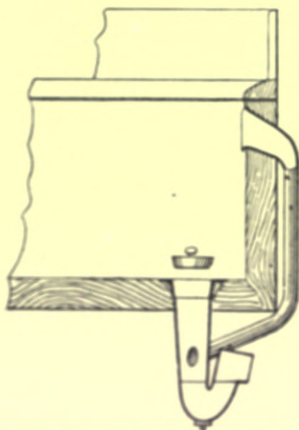

Fig. 278.—Plug-waste and Overflow from Wood Sink.

also convenient that arrangement should be made for permitting the water to run through continuously. For these purposes an overflow orifice is necessary, and it is most essential that this should be readily accessible for cleaning in all its parts. There are several methods of arranging the **overflow and waste**. The ordinary plug-waste and overflow for a lead-lined wood sink are shown in fig. 278. In a cast-iron sink (fig. 279) the waste-outlet is closed by an ordinary brass plug and washer, and the overflow is carried away through a series of slots by a sort of by-pass formed in the end of the sink, to the waste-pipe just below the plug. The overflow arm in this case cannot

be properly cleansed, and is therefore liable to become offensive.

Fig. 280 shows a section of the overflow in a glazed fire-clay sink, which is an improvement on the last, inasmuch as the overflow arm is continued up to the top of the sink, and can be cleansed by means of a long brush.

Fig. 281 shows an arrangement that can be adapted to any kind of sink, and one in which the overflow arm is entirely dispensed with. The funnel, which can be made either in nickel-plated brass or tinned copper, acts both as overflow

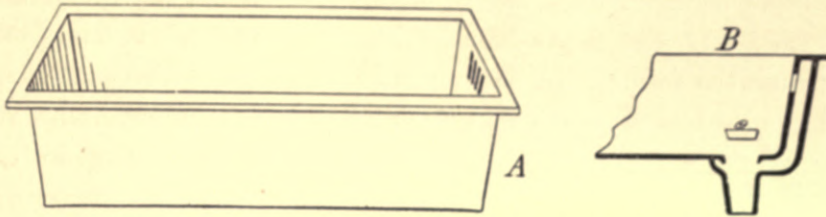
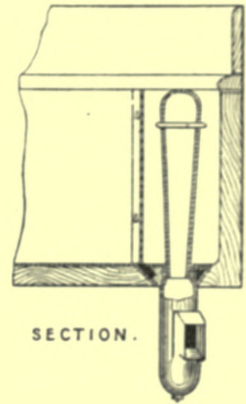

Fig. 279.—Cast-iron Kitchen sink. A, Sketch; B, Section of Waste Overflow.

and plug, and can be readily lifted out by the ring at the top. To guard against breakage by impact against the funnel, and also to prevent floating substances escaping into the waste, a tinned copper strainer can be fixed round the funnel. Another plan is to form the overflow in a sort of projecting recess, somewhat after the manner of the lavatory shown in fig. 271; this is an arrangement peculiar to glazed fire-clay sinks.

The form of **grating** to be fixed in the waste-outlet of a sink should be carefully proportioned to the area of the waste-pipe itself. For example, if the waste-pipe be 2 inches in diameter, the sum of the areas of all the openings in the grating should equal the area of the 2-inch waste-pipe. For this purpose the mouth



SECTION.

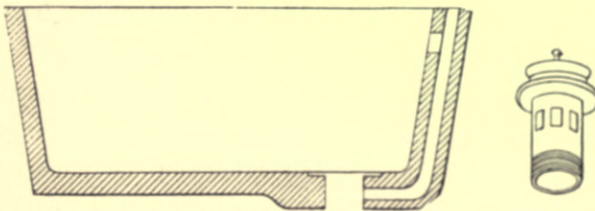
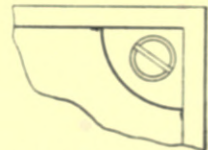

Fig. 280.—Section of glazed Fire-clay Sink, showing Waste and Overflow.



PLAN

Fig. 281.—Plan and Section of tinned copper Strainer and Standing Waste.

of the waste-pipe between the outlet and the trap should be widened out to give the requisite surface. A very common fault in waste-fittings is that the free way of the outlet grating is much less in area than the area of the waste-pipe, and in consequence the discharge of the water (which ought to be as rapid as possible) is sluggish, and neither the sink nor the trap gets the scouring-out which is so desirable.

The sinks described above have all been for the purpose of washing utensils used for food or for its preparation. Another kind of sink has now to be considered, viz., the **slop-sink**. The use of a slop-sink is, in dwelling-houses, for the emptying of bedroom slops, and though it is far better to arrange the water-closet in such a way that it can be used for this purpose, it becomes sometimes desirable to use the former. A convenient arrangement, where sufficient space is available, is to fix a slop-sink and wash-up sink side by side, with the waste

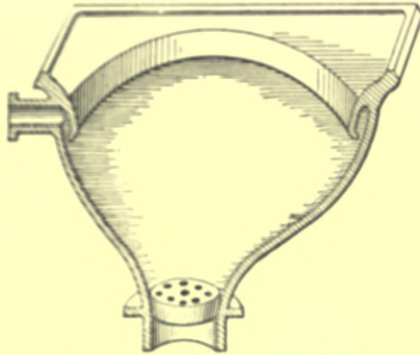

Fig. 282.—Section through glazed-ware Slop-sink with Flushing-rim and Grid.

from the latter discharging into the former. These sinks are made in glazed fire-clay, which is probably the best and cleanest material for the purpose. They are also made of cast-iron, finished inside with a porcelain enamel. The wash-up sink serves also as a draw-off sink for hot and cold water. The waste-pipe from a slop-sink should invariably be treated in the same manner as a soil-pipe from a water-closet, and the sink itself should be provided with a flushing-rim, as shown in

fig. 282, to which water should be laid on from a flushing-cistern of at least 2 gallons capacity.

In form a slop-sink should be either round or square. If the latter, the angles should be well-rounded, and the sides and bottom sloped to the outlet. They should of course be provided with a trap, which may either be of lead or of iron, enamelled white inside. This trap must be safeguarded against syphonage, either by being made in the "anti-D" form, or by being provided with an anti-syphonage pipe.

An apparatus designed by Mr. J. J. Lish, an architect of much experience and repute in the north of England, may conveniently be described here, as it combines in itself the following features:—1, a water-closet; 2, an automatic ventilator; 3, an urinal; 4, a lavatory; 5, a draw-off sink; 6, a slop-sink; 7, a fountain or rising douche-bath.

The water-closet itself is made in the form known as the wash-down or "hygienic", and in itself presents no features of an unusual kind. At the back of the seat is a high wooden casing, which forms a ventilating shaft, the upcast current of air being assisted by the hot-water pipe which is contained therein, and also by a gas jet placed here for that purpose. A reference to Plate XII. will make the disposition of the various parts clear. Immediately above the

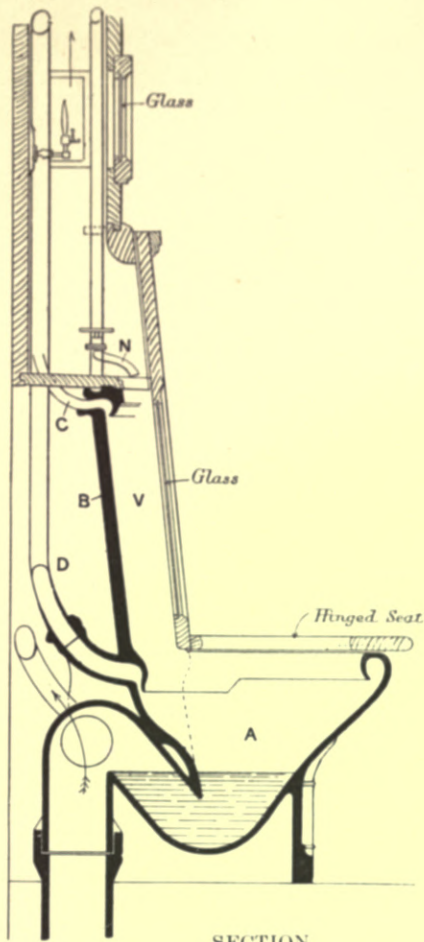

SECTION.

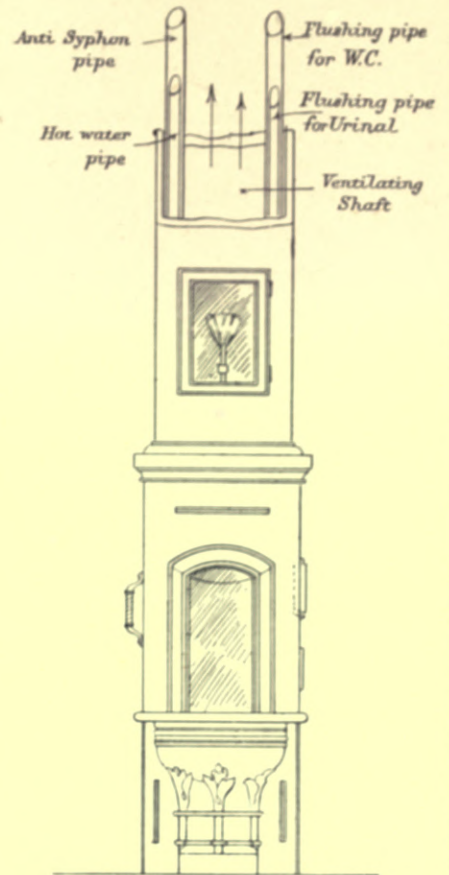

FRONT ELEVATION
(to a smaller scale).

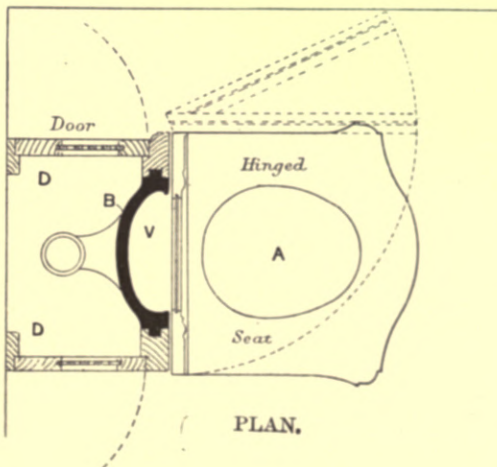

PLAN.

- A. Closet Basin.
- B. Urinal slab set on the rim of the W.C. basin.
- C. Flushing-pipe for urinal slab.
- D. Boxed-in space with doors for access, these doors being perforated to prevent any accumulation of foul air.
- V. Ventilation-shaft.

w.c. basin is an upright slab of porcelain, which serves as the urinal back. The seat of the w.c. basin is hinged to the panelled upright back, and the latter is hinged at one side. To expose the urinal for use the seat is turned up against the vertical back, and both are then opened together like a door. The urinal is flushed automatically at each usage with the contents of a half-gallon cistern. The flushing-pipe is shown at G in the section. Above the top of the urinal back is a nozzle, which communicates with both hot and cold water-pipes by means of taps. On to this nozzle a rubber-pipe is fixed with a Royle joint, and supplies water (either hot or cold, or both) to the fountain or rising douche-bath, which is made to fit on to the top of the w.c. basin. A basin, which fits into the rim of the w.c., is also supplied, which can be used either as a washhand-basin or as a bidet; the water being drawn from the nozzle on to which the fountain bath-pipe is slipped.

The use of the apparatus as a slop-sink is sufficiently obvious to need no explanation, and hot and cold water are of course both readily accessible.

The action of the ventilation-shaft is such that a current of air is continually ascending from the drain or soil-pipe side of the trap, and from the surface of the basin to the outlet. Thus both sides of the trap are continuously air-washed, and any vitiated or offensive air in the w.c. is regularly extracted. Unfortunately no specimens of this most interesting invention have yet been fixed further south than Edinburgh, and the foregoing description has had to be compiled from diagrams and written information, and without reference to the actual thing. Enough has been said, however, to show that the apparatus is one of great merit, and, if in practice it fulfils all that its author claims for it, it is the nearest approach to a sanitarily perfect closet that has yet been made.

CHAPTER V.

WATER-CLOSETS.

A glance at the history of the subject shows that the use of water for the conveyance of fæcal matter from latrines is a practice of very considerable antiquity. Sir John Simon says that in Rome public latrines were in general use under Augustus, at any rate for the male sex:—"That at least some of them (*i.e.* latrines) discharged into the sewers is known from the language of contemporary writers; and that at least some of them more or less resembled the

trough water-closets of our own time, in having an ample water service by which their contents were flushed into the sewers, seems proven by the fact that apparatus of the kind has in several cases been discovered in the remains of Pompeii."¹ Mr. Hellyer, in his *Lectures on the Art of Sanitary Plumbing*, cites an example from Fosbrooke's *Encyclopedia of Antiquities*, of a water-closet in the palace of the Cæsars which was furnished with a cistern, from which water was distributed by pipes to several seats.

At the monastery attached to Canterbury Cathedral, Professor Willis traced the exact position and construction of the "third dormitory" or *necessarium*. The privies or closets were arranged in a row along one side of a great hall, and immediately under them ran a fosse or open sewer. Into this fosse or sewer, the rain-water from the roofs, and the overflow from the series of tanks by which the monastery was supplied with water, were led, thus forming what must have been a fairly-efficient trough-closet. Mr. Hellyer, in the lectures quoted above, refers to an early form of water-closet mentioned in Aubrey's "Surrey". At Sir Francis Carew's, Beddington, Surrey, Aubrey "saw a pretty machine to cleanse an 'House of Office', viz., by a small stream of water no bigger than one's finger, which ran into an engine made like a bit of a fire-shovel, which hung upon its centre of gravity, so that when it was full a considerable quantity of water fell down with some force and washed away the filth".² This apparatus, from its description, must have been curiously like some arrangements to be met with abroad at the present time.

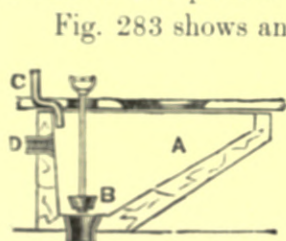

Fig. 283 — Section of an Eighteenth-century Water-closet.

Fig. 283 shows an apparatus that was probably the usual form in use during the last century, in the houses which were possessed of such luxuries. The pan was made of marble, and the outlet was closed by a wedge-shaped plug B, attached to which was a long handle; the water was admitted by a service-pipe C, and its height in the pan regulated by an overflow-pipe D. No trap was fixed under the pan, and the soil-pipe, unventilated, was carried direct to the drain.

An improvement upon this apparatus was **the valve-closet**, which, in various improved forms, remains in common use to this day. Though one or two valve-apparatus were designed and patented before Bramah produced his well-known closet, they need not be referred to further here. Joseph Bramah, a cabinet-maker, took out a patent for a valve-closet apparatus in 1778. This apparatus was the parent of all the succeeding closets of the valve-type, and though there may be little of Bramah's detail left, the leading principles remain the same.

¹ *English Sanitary Institutions*, by Sir John Simon.

² Hellyer, op. cit., p. 190.

The valve-closet consists essentially of two parts, the basin, and the valve-box and valve; to which must be added a third part, viz., the trap. The trap did not apparently form an essential part of the apparatus in Bramah's time, and it will be convenient to consider it separately.

Bramah's closet (fig. 284) consisted of a basin, at the bottom of which was a valve, which, when closed, seated itself close against the outlet, and thus served to retain any water which might be in the basin. The valve was worked by a cranked lever connected with a handle, which was raised to open the valve and lowered to close it. The water was admitted near the top of the basin, and its height in the basin was regulated by an overflow-pipe communicating with the valve-box. The weak point of Bramah's closet was—and this is the case with inferior valve-closets of to-day—the difficulty of ensuring that the valve should always shut down tight on its seating.



Fig. 284. —View of Bramah's Water-closet.

The apparatus known as the "**Pan-closet**" was probably devised with a view to correct the defects of the valve-closet. This apparatus consisted of three essential parts: the basin, the pan, and the container, and is usually found with a fourth, viz., the D-trap. The basin *m* (fig. 285) is in the form of a truncated cone; below this is the pan *o*, a circular vessel generally made of copper and fixed on a pivot, so that when the handle is raised, the pan falls and discharges its contents into the receiver *n*. The receiver is made of iron, and is large enough to give free play to the movement of the pan.



Fig. 285. —Section of Pan-closet.

The defects of this apparatus are so glaring, and its evils have been so frequently described, that it seems almost superfluous to enlarge upon them to-day. Indeed, the fact that the apparatus is, in many places, prohibited by by-laws sanctioned by the Local Government Board, would render further comment unnecessary, were it not unfortunately true that the thing continues to be made and fixed, notwithstanding all that has been done to demonstrate its

unfitness. Perhaps the chief defect is that in the container there is a very large area of metal, which is exposed to contamination by splashing at every discharge from the basin, and for the cleansing of which no provision whatever exists. The whole surface of the container, and the bottom and sides of the pan, are in course of time almost entirely covered with filth. That this is no exaggeration may readily be proved by anyone who will be at the pains to examine an old pan-closet, which has been in use for a few years. When the pan is lowered, the whole of this foul surface becomes exposed to the air of the house, and the resulting effluvia are better imagined than described.

The "D"-trap, referred to as usually forming a fourth part of the pan-apparatus, is not an essential adjunct, but is almost invariably found in connection with it. It is, as the diagram (fig. 286) shows, a receptacle or trap formed in lead, and roughly in the shape of the letter D. A short piece of lead pipe, connected to the bottom of the container, passes through the top of the D-trap, and is continued down until the mouth of it is about an inch or so below the bottom of the outlet-pipe. Everything therefore which passes from the closet is discharged into the trap below the standing-water line, and thus a water seal

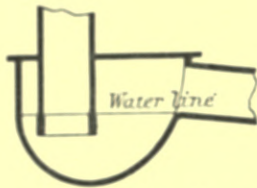

Fig. 286.—Section of "D"-trap.

is obtained. The form of this trap is peculiarly favourable to the deposit of faecal matter on all parts of its surface; more particularly on the edges of the dipping pipe and along the bottom. Several examples, showing more or less deposit, are to be seen at the Parkes Museum of Hygiene, London. Another common arrangement, which added its quota to the insanitary conditions of this closet, was that the waste-pipe from the safe under the apparatus was commonly conducted into the back of the D-trap, sometimes below the water-line. Altogether the pan-closet and D-trap present a typical example of nearly every kind of fault which can be accumulated in one apparatus.

To return to **the valve-closet**. It must be conceded that there are circumstances which justify, if they do not compel, the use of a valve-apparatus. For the best water-closets in private houses of the better type, and generally for closets intended for ladies' use, the valve-apparatus possesses advantages over the wash-out or wash-down closets, which will be described later on. The large body of water contained in the basin is a distinct advantage, and the quiet working of the apparatus is also of great value. But if a valve-apparatus is to be fixed, it should be the best obtainable. A cheap and flimsy valve-closet is only one degree better than the old pan-closet.

There are several forms of excellent valve-apparatus in the market, and it

would take more space than is available to describe and illustrate them all. In order, therefore, to avoid advertising one make of closet at the expense of others equally good, it will be best to set forth briefly the conditions which should be fulfilled by a good and serviceable apparatus. In the first place, the water should be admitted to the basin all round the rim, and not by means of the old-fashioned fan-spreader. The overflow should have a wide, open mouth, in such

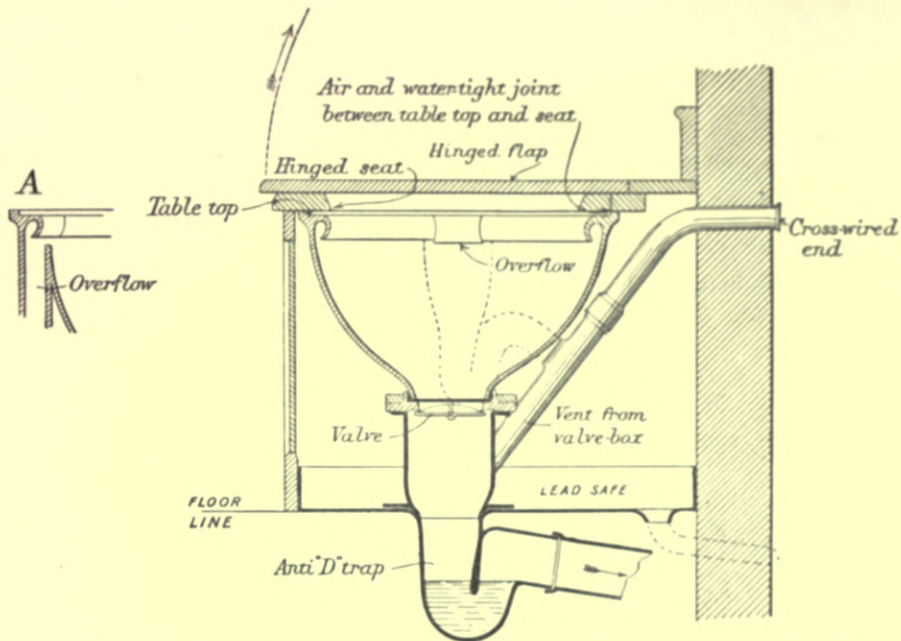

Fig. 287.—Section of Hellyer's "Optimus" Valve-closet and Slop-closet: A, Section of Down-right Overflow.

a position that the whole of the arm can be readily got at for cleaning. The overflow itself should not only be properly trapped, but should be thoroughly flushed out at every use of the basin. The working parts of the valve should be as simple and as strong as possible, and the interior of the valve-box should be porcelain-enamelled. The valve-box should be ventilated, and the overflow-arm should be connected into the ventilating pipe, so that the part just above the opening into the valve-box may be flushed regularly. Underneath the valve-box should be a lead trap, to cut off air-connection between the closet and the soil-pipe. The ventilation-pipe to the valve-box will prevent the trap from syphoning out when the contents of the basin are discharged. As an example of a valve-closet which fulfils all these conditions, we give an illustration of Hellyer's "Optimus" closet (fig. 287).

The next type of apparatus to be considered is **the plug or plunger closet**. The plug-closet was first devised by the late Mr. Jennings, and was a praise-

worthy effort to produce a closet in which the defects of the pan-closet should be avoided, while the mechanism of the working parts should be simpler in construction than those of the valve-closet. It was also an attempt to reduce the amount of metal used, and to increase the amount of porcelain—a step in the direction of the more sanitary fittings of the present day. The apparatus consisted originally of a basin, at one side of which was a plug-chamber, or cylinder, in which was a plug with a hollow handle. Should the water in the basin rise above a certain point, it would flow down the hollow space in the plug-handle, which thus became an overflow. The plug, on being raised, allowed the water in the basin to flow out into the trap below. The objection to this apparatus was that the plug-chamber and the plug itself were liable to get fouled and become offensive. The overflow arrangement also was obviously open to the same objection. In the improved form of this closet the plug-chamber is abolished, and an overflow-arm substituted for the hollow plug-handle. These are substantial improvements, but the objectionable plug still remains.

A modification of this apparatus is the trapless closet (fig. 288), called by one maker the "twin-basin closet". This apparatus has all the objectionable

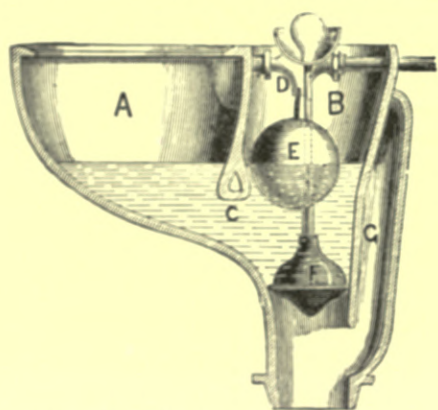

Fig. 288.—Section of the Twin-basin Closet.

features of the original plug-closet, combined with the added defect of there being no trap under the outgo. The closet is formed of two compartments, divided from each other by a septum or partition, which dips into the water, but allows a free passage between the two. The larger compartment forms the basin, while the smaller contains the plug and a ball-valve for regulating the admission of the water. The liability of the plug and the parts about it to become fouled is the same with this apparatus as with the plug-closet described

above. It is evident also that, unless the plug is always forced well down into its place, the water in the basin will leak out; and the same thing would happen if paper got jammed between the plug and the side, and so prevented the plug from fitting tight. In either case the basin would become drained of its water, and the overflow-opening, which is in the plug-chamber, would become a free passage for drain-air to pass into the house. What advantage is to be gained by the omission of a trap under the apparatus it is not easy to see. The trap is the only protection against the free admission of drain-air from the soil-pipe

into the house; and if it is eliminated, the air from the drain will most certainly rush in every time the basin is emptied.

The next class of apparatus to be considered is one in which the water used for flushing is the waste-water from a sink or sinks, and is not specially laid on for the purpose. These closets are known as "slop-closets", and the particular kind we propose to describe is that of the "tumbler" or "tipper" closets. The

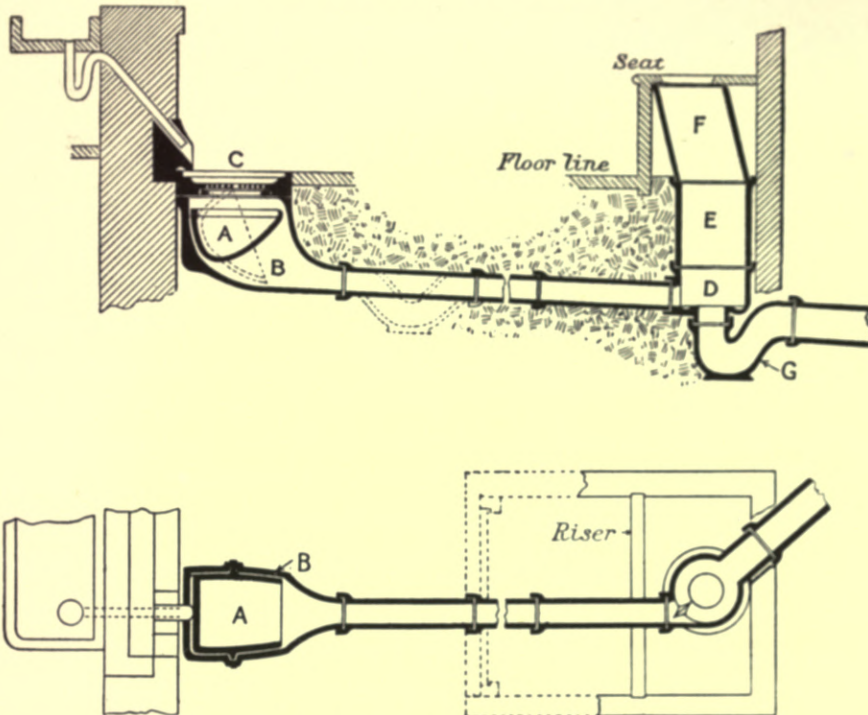

Fig. 289.—Plan and Section of Duckett's Automatic Slop-water Closet.

advantages claimed for this kind of closet are (1) that they are less expensive to fit up than any other kind: (2) only slop-water is used for flushing, and no charge can be made for water-rate in respect of them; (3) they are not affected by frost; and (4) they are, with fair usage, not liable to get out of order. They are, however, only suitable for out-door closets, and for a working-class population. The tipper or tumbler can be fixed either immediately under the seat, or at a distance. In the first case, the seat must be fixed in such a position in relation to the sink (down the waste-pipe of which the slop-water is poured) as to allow sufficient fall for the water. The second arrangement is applicable where there is not sufficient fall to allow of the former.

As an example of the first class, fig. 289 shows a plan and section of Duckett's patent automatic slop-water closet. The apparatus consists of a circular pedestal,

E, of glazed earthenware; below this is a basin, D, into which the box, B, containing the tipper, A, opens—either directly or by means of the drain-pipes shown. The basin is set on a syphon-trap of ordinary form, G, and around the outlet is a raised rim or stop, which forms a sort of shallow channel all round. This arrangement has the effect of causing a sort of whirlpool action to the water discharged from the tipper, and effectually clears out of the basin every-

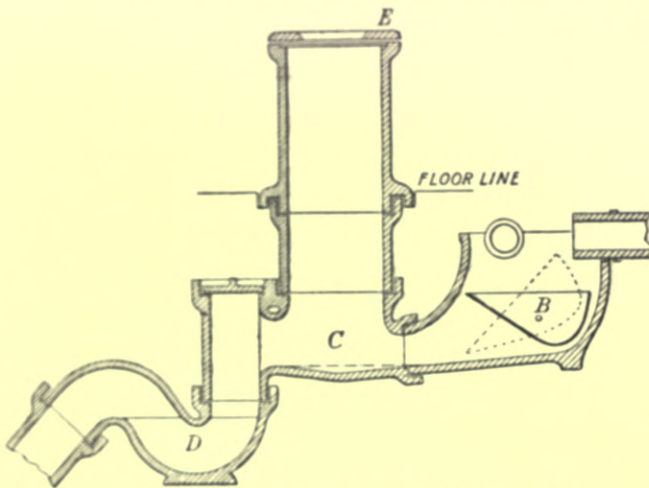

Fig. 290.—Section of Oates and Green's "Skroy" Waste-water Closet.

thing that is deposited by legitimate use. The capacity of the tipper is 3 gallons, and its action is perfectly automatic. The sloping pan F, is not so good a form as the upright pedestal, and may be replaced by a second vertical pan. C is the grate over which the sink-waste discharges.

Another good example of this form of closet is Oates and Green's "Skroy"

waste-water closet (fig. 290). The general form is very similar to the foregoing, the chief difference being that a slight depression in the pan, C, under the pedestal takes the place of the annular arrangement in Duckett's closet. B is the tipper, D the trap, and A the pedestal, on which the wood seat, E, is fixed.

Other forms of slop-closets, differing somewhat in detail, but all designed with the object of utilizing the slop-water of a house for flushing purposes, may be seen illustrated in a very interesting and valuable Report by Dr. Parsons on "Slop-closets and Trough-closets".¹

The trough water-closet is one in which two or more closets discharge into a common trough, which is emptied from time to time either automatically or by pulling up a plug. In the automatic kind, the water is maintained at a constant level in the trough by means of a weir, and flushing is effected by a cistern furnished with a syphon. Fig. 291 shows a section of Bowes, Scott, and Western's trough-closet with flushing cistern. The whole arrangement is made in glazed earthenware, and the cistern is provided with one of Mr. Rogers Field's annular syphons. Trough water-closets are specially suitable for schools, and for places

¹ Extracts from the Annual Report of the Medical Officer to the Local Government Board in 1890. London, 1892.

where ordinary arrangements for flushing would be likely to be misused or altogether neglected. For blocks of buildings inhabited by the rougher class of labourers and the like, they are eminently fitted. But wherever used, they should be out of doors, and have the most careful and constant supervision. An apparatus, in which fæcal matter is of necessity kept for some hours, is one which obviously demands to be used with discretion and kept with care.

Besides the apparatus illustrated, there are several forms, both in cast-iron

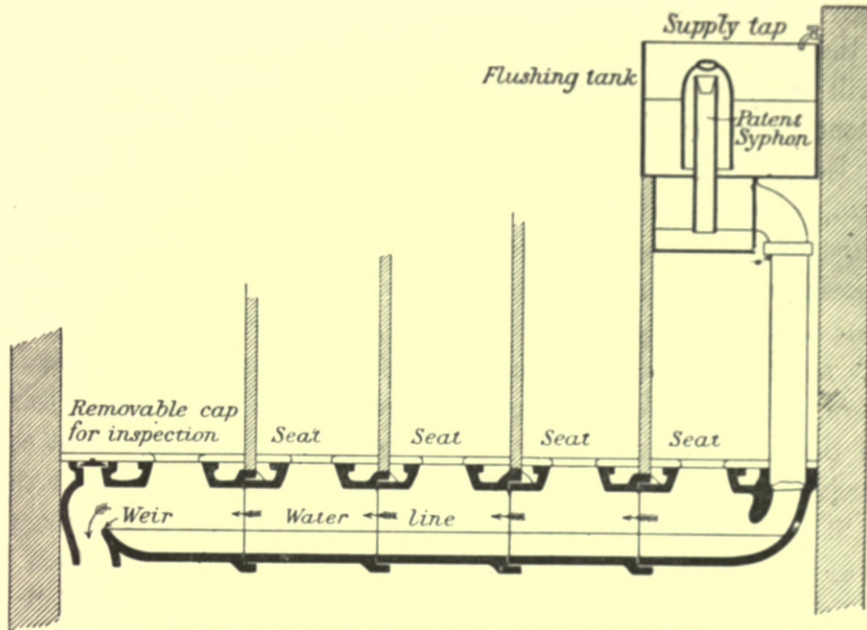

Fig. 291.—Section of Trough-closet with Automatic Flushing Tank.

and in enamelled or salt-glazed fire-clay, many of which are equally fitted for the purposes they have to serve. The important points are that there should be a sufficient quantity of water in the trough, but that it should not be wasted; and that the periodical flushing should be automatic, and quite beyond the control of those using the closets. The closets should also be separated one from another in the trough itself, by partitions dipping into the water. This can also be managed by providing each closet with an ordinary cone-shaped basin, the lower part of which dips about $1\frac{1}{2}$ inches into the water in the trough. It will be noticed that this separation is not effected in the trough-closet illustrated.

The apparatus, that have been hitherto dealt with, may all be classed together under the head of "mechanical" closets. We have now to consider what, for want of a better name, may be called "**non-mechanical**" apparatus. The difference consists in this: that in the former class, the arrangement for controlling the flush of water is in close connection with the basin and forms

part of it, while in the latter the mechanical parts are connected with a cistern, and form no part of the basin or closet. The various apparatus coming under the head of "non-mechanical" comprise the following: hopper, wash-out, wash-down or short-hopper, and syphonic.

The **hopper closet**, now happily almost universally condemned, consists of a long funnel-shaped basin with a trap underneath, its means of flushing being a dribble of water from a small pipe, turned on occasionally or more often leaking continually, with no perceptible effect on the cleanliness of the basin or the contents of the trap.

It will be convenient here to see what the **Model By-laws of the Local Government Board** prescribe as the necessary conditions for a sanitary water-closet. Every water-closet must, according to these by-laws, be provided with "*pan, basin, or other suitable receptacle of non-absorbent material, and of such shape, of such capacity, and of such mode of construction, as to receive and contain a sufficient quantity of water, and to allow all filth which may from time to time be deposited in such pan, basin, or receptacle, to fall free of the sides thereof, and directly into the water received and contained in such pan, basin, or receptacle*". From this regulation, it is perfectly clear that a basin of the long-hopper type is quite inadmissible, inasmuch as it could not comply with the important condition that filth should fall clear of the sides. Further, it is impossible to wash out a basin of this type by any ordinary means.

It was to provide an efficient substitute for the long-hopper closet that the **wash-out closet** was devised. This closet (fig. 292) consists essentially of two

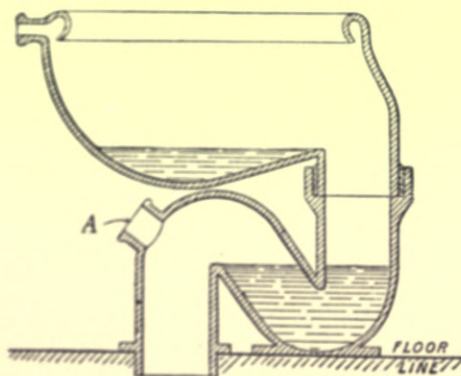

Fig. 292.—Section of Wash-out Closet.

parts, the basin and the trap, which are either made separately or in one piece of earthenware; sometimes a junction is formed, as at A in the illustration, to receive a trap-ventilating pipe. The basin is made to contain a small quantity of water, into which the dejecta fall. In order to flush out closets of this and the succeeding type, a jet of water impelled with some force is required, and this is usually supplied by means of a flushing pipe, connected with a flushing

cistern fixed at a sufficient height above the basin to give the required impetus. With closets of the wash-out type, the depth of water in the basin is often insufficient to cover the *fæces* deposited, and the effluvia arising is often most

offensive. The flush of water is not sufficient to clear out the basin thoroughly, and is of course quite inadequate to clean out the trap. The consequence is that the bottom of the basin is frequently stained, and the trap is never free from filth. These defects render this form of closet a most unsuitable one, except where the persons using it take extraordinary precautions to keep it in proper condition.

The "wash-down" or "short-hopper" closet (fig. 293) is probably the best for all purposes that can be had. The essential difference between it and the wash-out closet is that, whereas in the latter the trap is independent of, and underneath the basin, in the former the trap is a continuation of the basin, and forms

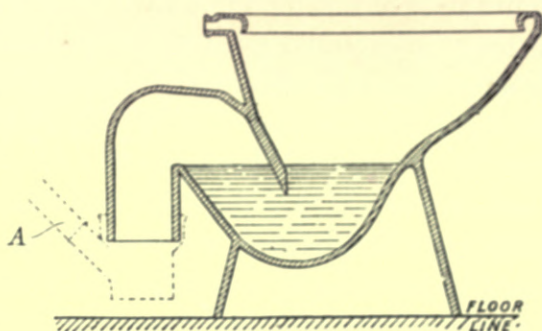

Fig. 293.—Section of Wash-down Pedestal Closet.

an integral part of it. The flush is applied in the same way, and in the best forms of the apparatus enters the basin both from a jet and round the rim. The method of connecting an anti-syphonage pipe is shown at A in the illustration. There are many varieties of the wash-down closet, called by all sorts of names. They are one and all based on the same idea, and must be regarded as good or bad according as they fulfil the condition of being most effectually cleaned out by the smallest flush of water. Some makers have even gone the very unnecessary length of covering the outside of the basin and trap with raised ornament, sometimes of a very elaborate type. Such an addition to a water-closet is obviously out of place, and in view of its liability to get fouled by splashing may be positively offensive. The outside and the inside alike of the closets should be as smooth, and, if of porcelain, as white as they can be made. Closets made of fire-clay are usually buff outside and white inside, because there is some technical objection to white enamel being used throughout. The chief point to bear in mind in choosing a closet is to see that the form of the basin is such as to allow the fæces to drop into the water without striking against the sides of the basin, and that the whole contents of the basin and trap are completely expelled by one discharge of the flushing cistern. The form of apparatus known as the "Kenon" closet,

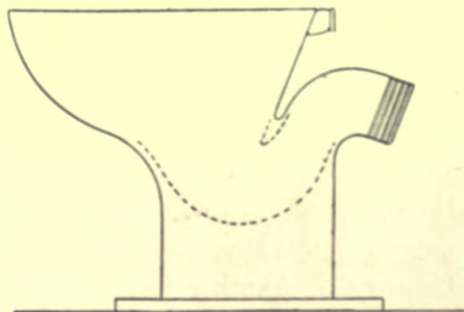

Fig. 294.—Elevation of the "Kenon" Pedestal Wash-down Closet.

made by Messrs. Bolding, is shown in fig. 294; it is made in one piece of earthenware with a broad flange for securing it to the floor.

Two other forms of wash-down closet are illustrated, because they show a special feature which is not present in any other make. The "Corbel" and the "Bracket", both patented by Mr. Hellyer, are examples of closets which are quite independent of the floor. They are shown in Plate XIII. The "Corbel" is made in one solid piece of fire-clay, and, like the lavatory basins of the same maker, has a flange of fire-clay, which is built into the wall and forms the support for the basin and trap. In the "Bracket" apparatus the basin only is made in fire-clay or porcelain, and requires the support of an iron bracket; the trap is made of lead. The great advantage aimed at in both these apparatus is the free floor-space for cleaning underneath. It is, however, gained at the expense of some additional cost, and is on the whole more suitable for hospitals and large institutions than for private houses. The drawback to the "Bracket" closet is that the trap is necessarily of lead, and it is difficult to see whether it is clean or not.

Closets of the wash-down or short-hopper type are made by several makers, with **porcelain trays** at the top, in order that they can be used as slop-sinks. The ordinary pedestal-closet is also well adapted for use as an urinal, and is indeed much more suitable for the purpose than many of the urinal-basins specially designed for the purpose.

The **syphonic-action closet** is an attempt to combine the advantages of the valve-apparatus and the wash-down closet. The basin holds water with a larger area and greater depth than can be obtained in the latter apparatus, but no mechanical appliances are needed in connection with the basin itself, as is the case with apparatus of the former class. The principle of the apparatus is that the contents of the basin, instead of being forced out by a jet of water, are syphoned out. The long leg of the syphon *D* (fig. 295) is filled with water, and, when the air above the water-level at the outgo of the basin is partially exhausted, the atmospheric pressure on the surface of the water in the basin starts the syphon in the usual way. The contents of the basin are then carried through the trap *C* into the soil-pipe *E*. The apparatus illustrated is that patented by Messrs. Jennings & Morley, and is called the "Closet of the Century". Another form of the same type of closet is the "Dececo", and yet another is Bolding's patent "Laydas" syphonic-action closet. The only possible defect in this type of apparatus is that it might be possible to syphon out not only the basin but the trap. But in the form chosen for illustration this appears to be amply guarded against by the anti-syphonage pipe *B*. The flushing of the

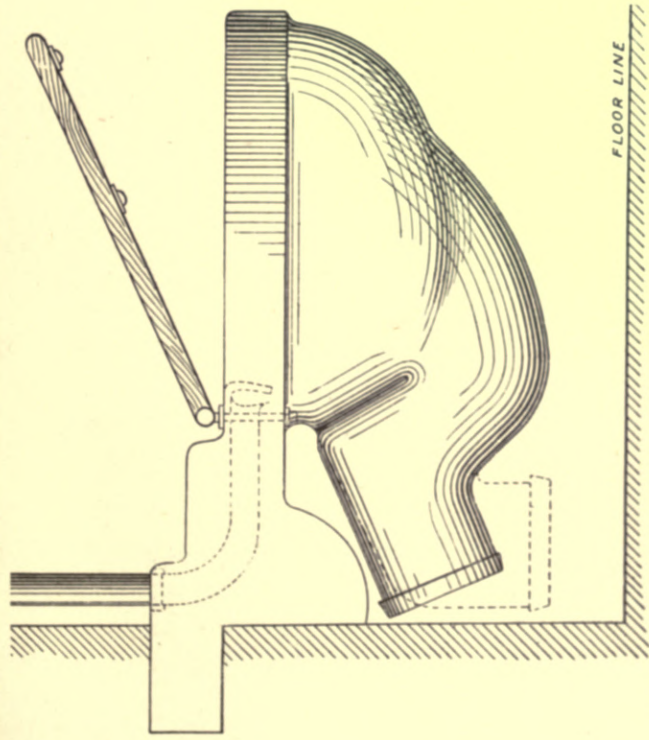

"CORBEL" W.C.

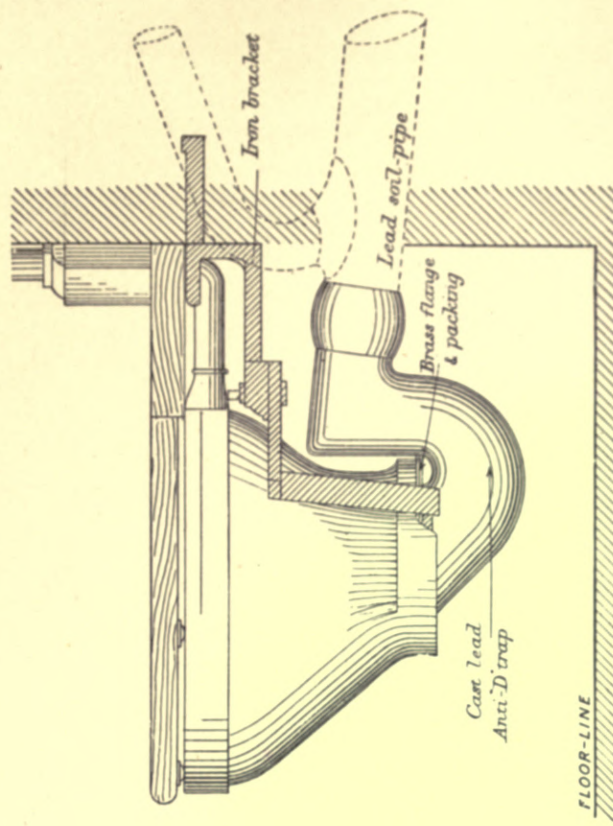

"BRACKET" W.C.

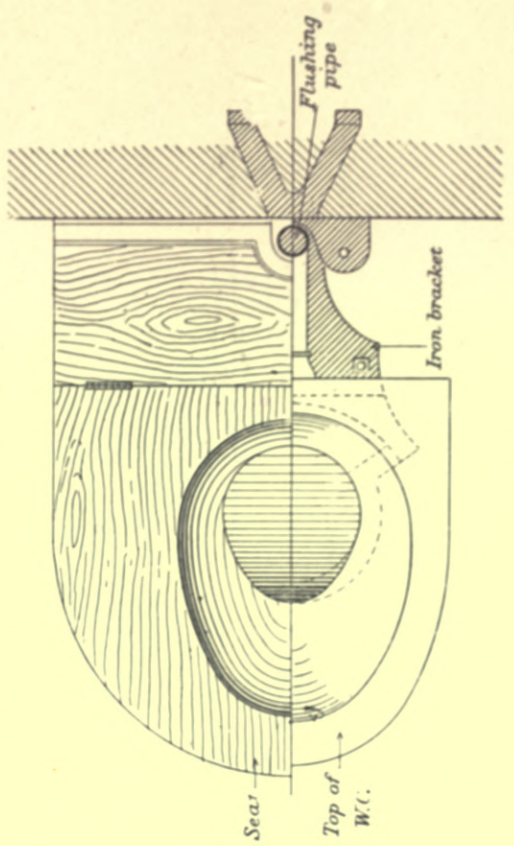
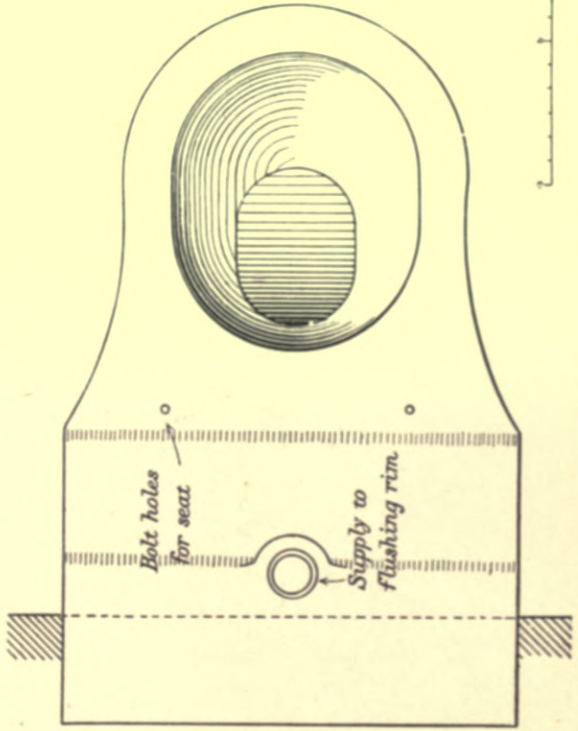

basin is also provided for by the arrangement for diverting the supply of water partly to the syphonic arm, and partly to the flushing rim of the basin. This very necessary safeguard is not provided in some other forms of this apparatus, and the obvious result of the neglect of this precaution is that the basin is never thoroughly cleaned out.

The subject of **seats and casings** to water-closets must now be considered. The question of the desirability of casings to water-closets has been briefly alluded to in the introductory remarks in this section. A well-made casing to a water-closet, especially if the apparatus is of the valve-type, is certainly neater and more sightly than the cranks and levers of the mechanism itself. It serves, moreover, the useful purpose of deadening the sound caused by the use of the apparatus; and for ladies' use it has certain not unimportant advantages, which need not be more particularly specified. In mansions and in houses of

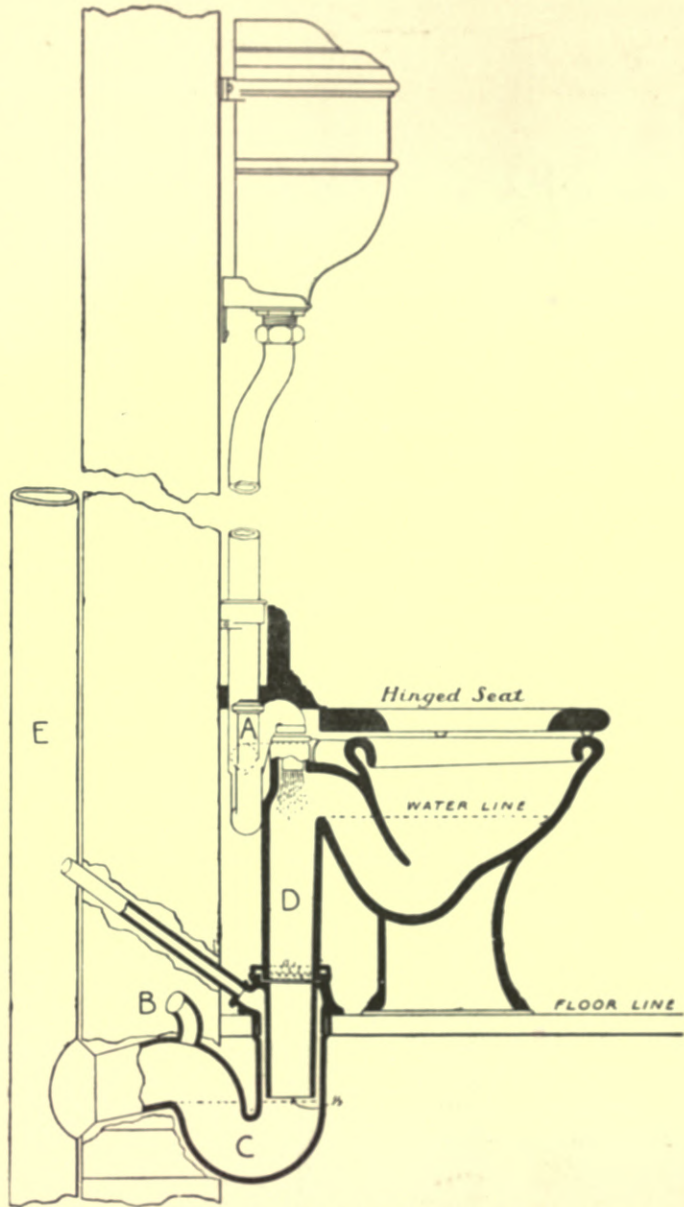

Fig. 295.—Jennings & Morley's Syphonic Water-closet.

the more expensive type, where the best workmanship and materials can be applied, it is certainly desirable to incase the best water-closets. But in all other cases, unless the work can be done in the best way, it is better to have a simple rim seat, hinged at the back. If the plain rim seat following the curve of the

basin be objected to, it is quite easy to carry the seat on brackets fixed on either side wall so that it extends the whole width of the closet.

The proper method of making a perfect joint between the porcelain or fire-clay outgo of a wash-down water-closet, and the lead branch to

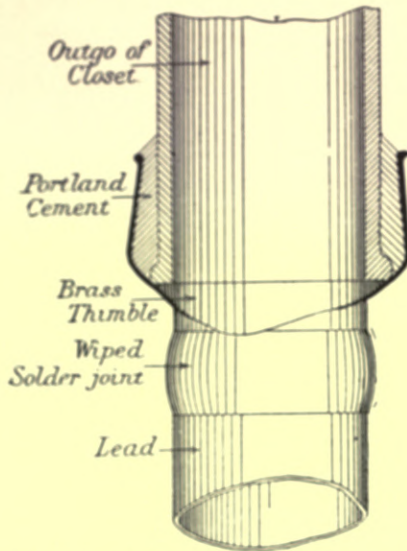

Fig. 296.—Joint between Earthenware Outgo of Closet and Lead Branch of Soil-pipe, as required by the London County Council.

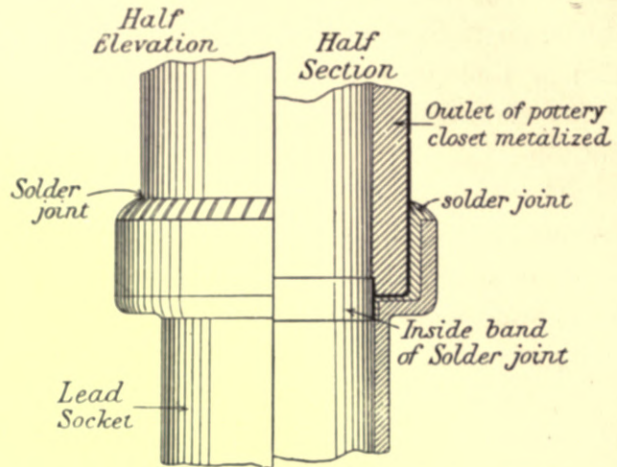

Fig. 297.—Doulton's "Metallo-ceramic" Joint between Earthenware and Lead.

the soil-pipe, is a point of great importance and not a little difficulty. The joint required by the regulations of the London County Council is made with a

brass thimble, which is jointed to the lead-pipe with a wiped solder-joint, and to the porcelain outgo of the closet with Portland cement (fig. 296). It is questionable whether this joint is a really permanent one. The solder-joint between brass and lead is of course, if properly made, a perfect union, but the Portland cement between the brass and the porcelain, being liable to expansion and contraction, may after some time become detached from the surfaces to which it ought to adhere. Doulton's metallo-ceramic joint (fig. 297) is really a solder-joint in a lead socket, with the outer surface of the porcelain metallized to take the solder. Time

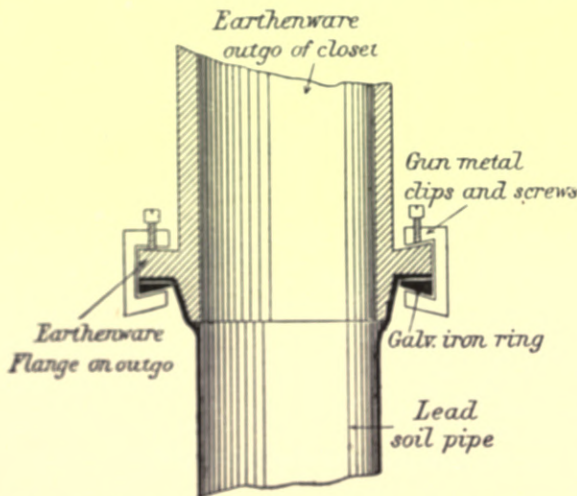

Fig. 298.—Flange Joint between Earthenware and Lead, with Clips and Screws.

Time

will show the durability of this joint. It certainly has the merit of being neat in appearance and easily made. The flange method (fig. 298), is a good joint, but requires to be examined from time to time, and the bolts tightening up when required. It is, however, not allowed by the regulations of the London County Council. Fig. 299 is a less satisfactory form of flange-joint. Freeman's lead connection (fig. 300) is practically a screw-joint. The difficulty with this seems to be that if at any time the joint required to be tightened up, the pipe would have to be sundered, as it is quite evident that the closet could not be turned round. Mr. Hellyer has devised

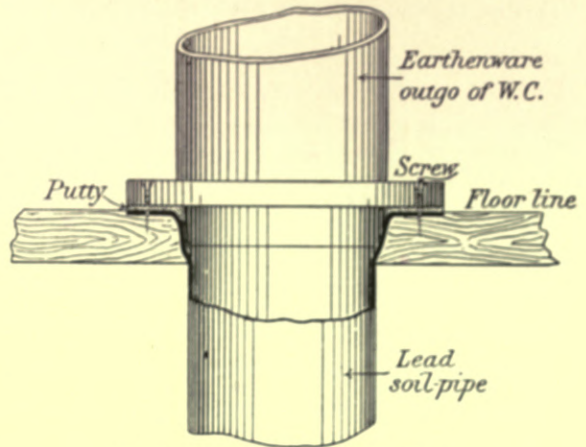

Fig. 299.—Flange Joint—screwed to Floor.

what he considers an improvement on the Portland-cement joint by substituting an elastic cement for the Portland cement. The socket of the brass thimble (fig. 301) is filled with alternate rings of elastic cement and yarn, and by this

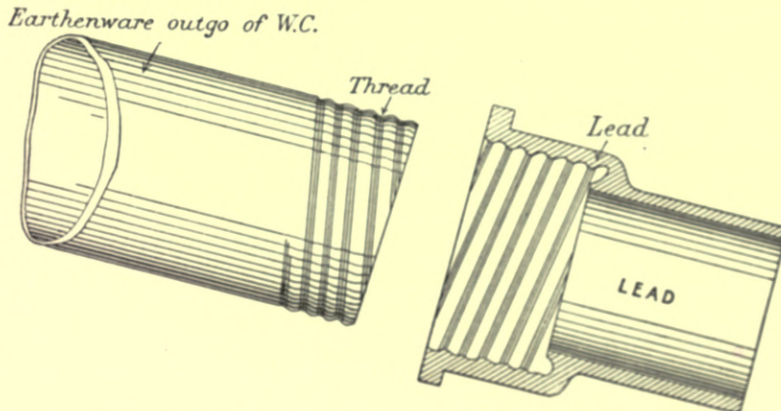

Fig. 300.—Freeman's Screw Connection between Earthenware and Lead.

means it is hoped to obtain a joint which is not affected by expansion and contraction. Humpherson's joint, shown in fig. 302, is formed by placing the end of the closet-outgo into the socketed end of the lead pipe, and covering the joint with an india-rubber collar kept in position by a copper clip; it is doubtful if this will make a permanently-tight joint.

In all forms of wash-down closets where the trap is of the same material as the basin, the form of the trap is necessarily that of the ordinary so-called

syphon or round-pipe trap. As no trap is so easily cleansed, so is no trap more readily unsealed or syphoned out; and it is frequently necessary to provide against such an occurrence. **The syphonage or unsealing of traps** is caused by the disturbance of the atmospheric pressure on the water in the trap, by the

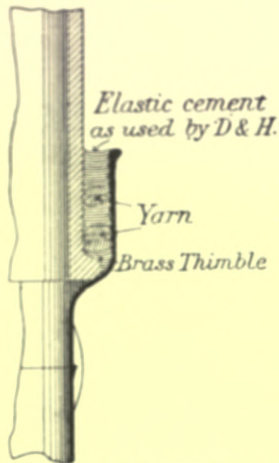

Fig. 301 - Hellyer's Joint with Brass Thimble and Elastic Cement.

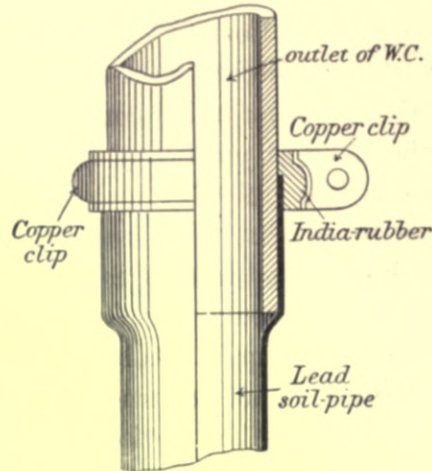

Fig. 302.—Humpherson's Joint.

sudden discharge of a volume of water either down the main pipe with which the trap is connected, or into the apparatus to which the trap belongs. It can only be obviated in the case of a round-pipe trap by fixing a ventilation-pipe to the trap itself on the side furthest from the closet, as shown at A in figs. 292 and 293, and B in fig. 295. In the case of a stack of two or more closets discharging into one soil-pipe, each trap should be ventilated into a vertical pipe, which should be carried up and connected to the ventilation-pipe of the soil-pipe above the highest w.c., as shown in Plate X.

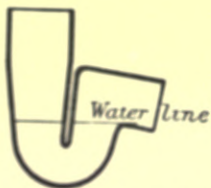

Fig. 303.—Section of Anti-D Trap.

In cases where lead traps are used, the **Anti-D trap** (fig. 303) will as a rule obviate the necessity for a trap-ventilation pipe. This trap was devised by Mr. Hellyer with a view to prevent syphonage by allowing space for expansion, and under very severe tests has proved equal to the task. It is well, however, not to depend too implicitly on the trap, but

to make assurance doubly sure by providing the anti-syphonage pipe.

The flushing arrangements for closet-basins have been described with each class of apparatus; but it may be well to emphasize one or two special points. No closet of the "wash-down" type can be admitted as satisfactory, unless it has an adequate flushing rim. It is absolutely essential to the cleanliness of this kind of basin that the sides of the basin should be washed down at every flush.

It is also necessary, though perhaps not so vitally essential, to the valve-closet. To the latter class of closets, what is called an "after-flush" is most essential. Wherever the quantity of water used at each discharge of the closet is restricted by local regulations made in virtue of legal powers, a part of the water used for flushing should be retained, and only admitted to the basin after the valve is shut down. This is called the after-flush, and is required in order that the whole of the water allowed for flushing shall not be sent out of the basin, and the latter left dry.

In most places where a public or municipal water-supply exists, **the quantity of water** to be used at each discharge of the contents of a water-closet is restricted by by-law or regulation. This restriction is necessary in order to control the consumption of water, and prevent waste; but it cannot be denied that it may, and under some circumstances does, become very prejudicial to health. It is obviously right and proper that waste should be prevented, but to fix a hard-and-fast limit to the quantity of water to be used at each discharge of a closet, without reference to the position of the closet in regard to the drain, or to that of the drain in regard to the sewer, is absurd. We must, however, take the law as we find it, and do the best that can be done under existing circumstances. The regulations vary in different localities, but the variation is so slight that it may be taken that the great majority of local authorities (including all the Water Companies of London) have fixed the limit of water to be used at each discharge at a maximum of two gallons. Now it may be admitted at the outset that, given a basin and trap of perfect form, and a flushing pipe of sufficient size fixed with accuracy, a flush of two gallons is under ordinary circumstances sufficient to clear out the basin and trap, and leave clean water for the next user. Experience, however, proves that the two-gallon maximum of the authorities should really be a minimum, and that in many cases a larger quantity is required.

Whatever the quantity of water may be, it should be delivered in full and automatically; that is to say, the total quantity should be discharged into the basin at every pull of the handle, without it being within the power of the person using the closet to restrict the amount. Many inferior kinds of flushing cisterns, or "**water-waste preventers**" as they are more properly called, only discharge their full contents if the handle or pull is kept down until the flow of water ceases. This form of flushing cistern is much in favour with Water Companies, whose sympathies are, naturally enough, on the side of economy of water, and not in any way concerned with the sanitary side of the question. It is of course very necessary and desirable that water should not be recklessly

wasted; but it is of far greater importance to the health of the community that sufficient water should be available for efficient flushing.

The cisterns which have been referred to as discharging their whole contents automatically, are, with one or two exceptions, constructed on the principle of a syphon, and are therefore often known as "**syphon cisterns**". The pull of the handle brings into action mechanism of some form or other, which, by disturbing the balance of air-pressure, starts the syphon and empties the cistern. One of the

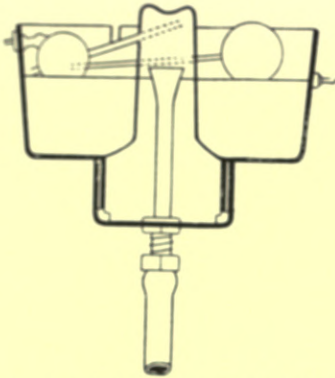

Fig. 304 — Section of Bean's Direct-acting Valveless Waste-preventer.

earliest and simplest of this kind of flushing cistern is "Bean's Patent Direct-acting Valveless Waste-preventer". A section of this apparatus is given in fig. 304, and will serve as a type of many others of varying excellence. The syphon is started by pulling the handle or chain attached to the lever, one end of which is fastened to the dome or short leg of the syphon. The dome being lowered, water flows over the lip of the long leg of the syphon, the pressure of air above the water inclosed between the long and short legs is reduced, and the syphonic action is started. There are numberless devices

for attaining the same end, some of them more complicated than others; but it is scarcely necessary or profitable to describe their many variations of detail.

A flushing cistern that answers well in practice, and contains neither valve nor syphon, is one in which the water is discharged by **the tipping of a receptacle** hung in the cistern on pivots. This also may be classed with the automatic type of cistern.

Reference must be made to **flushing cisterns provided with valves**. They are not to be recommended for general use, inasmuch as the valve is closed, and the flow of water ceases immediately the handle is released. They are useful for supplying valve-closets, because the after-charge can be arranged with ease and simplicity.

One great objection, that is commonly and with much reason urged against all classes of flushing cisterns, is the **noise** that seems inseparable from the use of even the best. Noise to some extent is inevitable when a large body of water is discharged quickly; but anything that reduces or minimizes the avoidable noise, *i.e.*, that which results from the mechanism of the apparatus, is a distinct gain. The noise of the water entering the cistern may be greatly reduced by carrying the inlet pipe to the bottom of the cistern, as in Merrill's "Noiseless" cistern,

and a new cistern has recently been brought out, known as the "Water-witch", in which the same end appears to have been gained.

Portable water-closets with cisterns at the side are simply an improvement on the ordinary commode, and belong really more to furniture than to sanitary fittings. The water is forced into the basin by a small hand-pump, worked by a handle fixed in the ordinary way at the side of the basin.

The question of **automatic flushing** by a mechanical apparatus, connected either with the seat or the door of the closet, has been frequently attacked, but it cannot be said to have been successfully grasped. By an arrangement of levers attached to the seat, the water is admitted to the basin either before or after use, the weight of the user setting the machinery in motion. Another plan is to connect the outlet-valve of the flushing cistern by a rod and crank with the door of the closet, so that each time the door is opened the basin is flushed. In either case the mechanism involved is of such a nature that it is very easily put out of order, and when that is the case, the closet is worse than useless. The object aimed at is a most excellent one; and any one who invents a really efficient and lasting automatic apparatus will confer a great boon on the community.

CHAPTER VI.

URINALS.

Of all the various fittings which come under the head of sanitary appliances, the urinal is the most difficult to deal with. **Urine** contains 54 per cent of urea, which decomposes very rapidly, producing carbonate of ammonia, the pungent and offensive smell of which is familiar to all. Another constituent of urine is uric acid, which is only feebly soluble in water, and which readily adheres to any dry surface with which it comes in contact, causing the well-known "furring" so commonly to be observed in ill-kept urinals. The decomposition of urine is much assisted by heat, and for this reason the free ventilation of urinals is of the utmost importance. For ordinary domestic purposes, a fixed urinal is unnecessary and undesirable. With proper care in the use, a **pedestal-closet of the wash-down type**, with a hinged seat, affords the necessary convenience in the way least likely to become offensive. But it may be urged that a closet basin is not arranged in the most convenient way for the purpose, and that unless great care is taken, the floor is liable to be splashed. There is much truth in

this, and for this reason it is perhaps best to keep an ordinary chamber-utensil in the w.c.

There are circumstances, however, which necessitate the provision of a properly-devised urinal, as, for example, a boarding-school for boys, or an establishment in which a considerable number of men-servants are employed.

Where a **range of urinals** is required, the best plan is to form a trough, either in iron or in salt-glazed or enamelled fire-clay. At the outlet end of the trough

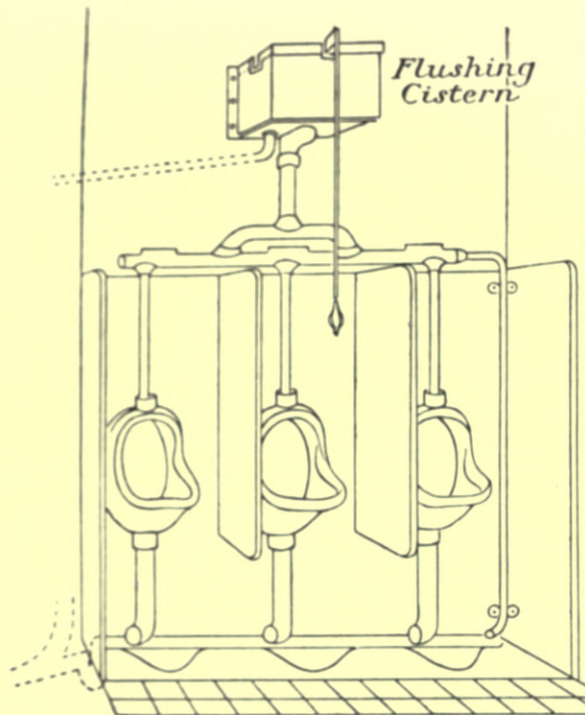

Fig. 305.—View of Urinal with three Basins, Flushing Cistern, Floor-channel, &c.

is a weir, by means of which the trough is kept constantly full of water, and the urine is always very largely diluted. An automatic flushing tank, the capacity of which should of course bear a definite relation to the size of the trough, is fixed over the end furthest from the outlet, and being set to discharge at certain intervals, flushes the trough and leaves it full of clean water. It is necessary, with this form of urinal, to provide for carrying away any urine that may be dropped clear of the trough. This is done by forming a small channel just in front of the trough, and providing a subsidiary flushing pipe for cleaning it when the trough is flushed.

A very much improved form of **stall-urinal** has come much into use of late for public urinals. Formerly these conveniences were usually formed of slate, and sometimes provided with porcelain basins. The slate very speedily becomes coated with uric acid, and is extremely offensive; and the ordinary basin with its grated outlet, small waste-pipe, and feeble flushing apparatus, is worse than useless.

The improved form referred to consists of a semicircular back of enamelled fire-clay, with a dished and rounded floor of the same material. The latter drains into an open channel covered with a grating, and discharging into a trap connected with the drain. The whole is flushed with a sparge-pipe, curved to the form of the back. Though there is, in an urinal of this description, a large

exposed area liable to be soiled, the absence of any corners, and the frequent flushing of the glazed surface, keep it always perfectly inoffensive and sweet.

This kind of urinal is perhaps to be preferred to the trough kind, where the quantity of water available is restricted. But in either case the urinal should be placed in a freely-ventilated and well-lighted building, entirely cut off from the interior of the house to which it belongs.

There are positions, as, for example, the lavatory attached to a billiard-room

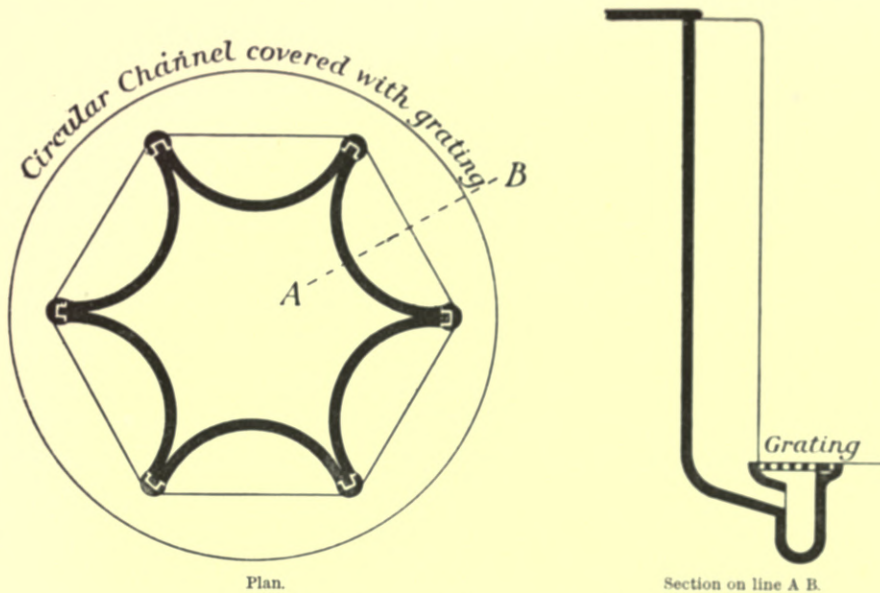

Fig. 306.—Plan and Section of a Group of Six Urinal-basins.

in a private house, where a single or perhaps two urinals are deemed a necessity, and it is cases such as these which demand the utmost care in arrangement. Fig. 305, which is reproduced by permission of Mr. S. S. Hellyer from *The Plumber and Sanitary Houses*, shows a three-basin arrangement of this kind. The basins are of the wide-fronted kind, a form which owes its origin to a suggestion of Mr. John Taylor, the well-known architect to H.M. Office of Works, and which is a great improvement on the old lip-fronted form. The down-pipes from the basins are all made of cast-iron, porcelain-enamelled inside and out, and are detachable for cleaning purposes. They discharge into an open channel, which has a trap with proper ventilation at one end. The sides, backs, and floor are all made of St. Anne's marble, which, when polished, successfully resists the action of urine. The flushing is provided for by a small tank containing three gallons of water, and it is possible to arrange the flushing pipes in such a way that one gallon of water is discharged into each basin at each pull of the

handle. The flush can also be made automatic and regulated to discharge at certain intervals.

To ensure the waste being kept free from deposit, Mr. Hellyer recommends that a piece of soda should be kept in each basin.

The plan and section of a compact group of six urinal-basins are given in fig. 306.

SECTION VIII.—DRAINAGE

BY

WILLIAM SPINKS

ASSOCIATE MEMBER OF THE INSTITUTION OF CIVIL ENGINEERS; MEMBER OF THE SANITARY INSTITUTE;
LECTURER ON SANITARY ENGINEERING AT THE YORKSHIRE COLLEGE (VICTORIA UNIVERSITY), LEEDS; PRESIDENT OF THE
INSTITUTE OF SANITARY ENGINEERS; AUTHOR OF "PAVING PRIVATE STREETS", "VILLAGE DRAINAGE",
"HOUSE-DRAINAGE MANUAL", &C.



SECTION VIII.—DRAINAGE.

CHAPTER I.

GENERAL DESIGN.

One of the prime necessities of life is an abundant supply of pure water for dietetic and cleansing purposes; after use, in the first case, it is voided by the body, and in the other, it is fouled either by personal ablution, or in the washing of houses and their contents, and in both cases it must be disposed of so as not to be a nuisance either to the occupants of the house from which it is discharged or to the community at large. Man in his primitive state disposed of the liquid refuse from his dwelling by turning it on to the surrounding soil. It is not necessary here to enlarge upon dangers that have from time to time arisen from the accumulated pollutions thus created; every student of history is familiar with the devastation caused by the several outbreaks of plague in this country (and of cholera within the memory of many now living), and the inception of sanitary science as now practised may be attributed to the lessons taught by the great scourge of 1848 and 1849.¹

However pure the air surrounding a house may be, however dry the site, and however wholesome the water available for domestic purposes, that house cannot be healthy unless there is provided some **system of conduits**, that will convey from its precincts all the liquid refuse before decomposition has set up. This is the function of the drain, which is spoken of here in its ordinary or popular sense, and not as defined by the Public Health Act, 1875, which will be referred to at a subsequent stage. There is still one other function for the drain to perform, and that is to carry off, in addition to the liquid refuse, a certain proportion of the rain which falls on or about the house. These being the two important purposes which a drain has to serve, it is necessary to understand all the circumstances affecting each.

¹ The terrible epidemic of typhoid fever at Maidstone in 1897 appears to have been due to a water-supply polluted in this way.—ED.

The first duty is to ascertain the amount of liquid refuse likely to be discharged from a house. For making large calculations for sewage-disposal purposes, from 20 to 30 gallons per head per day is assumed or taken from the returns of the water actually consumed, but in a large town some proportion of this water does not find its way into the house-drains, as it is used for a variety of public purposes (such as baths, fountains, watering streets, flushing sewers, extinction of fires, and trade purposes), and when we come to analyse the amounts consumed per house, we shall be surprised to find how great is the variation. Where people draw their water from stand-pipes, the daily consumption averages about 7 gallons per head, and in those communities where the water-supply is better but the conservancy-closet system prevails, it is about 10 gallons per head. On the other hand, we may find that in large houses, where the water is conveyed to every floor, and baths, lavatories, sinks, and w.c.'s are fitted, the daily consumption may be 40 gallons on the average, and may reach as much as 70, if the occupants indulge in the daily tub. Dr. Parkes says that he found 12 gallons to be the amount used by a clean healthy man of the middle class belonging to a fairly clean household, and this amount he subdivided as follows:—

| | Gallons. |
|---|----------|
| Cooking, | .75 |
| Fluids as drink (water, tea, coffee, &c.), | .33 |
| Ablution, including a daily sponge-bath taking two-and-a-half to three gallons, ... | 5.00 |
| Share of utensil and house washing, | 3.00 |
| Share of clothes (laundry) washing estimated, | 3.00 |
| | 12.08 |

Where water-closets are provided in the house, other 4 gallons at least should be allowed per head. If the closets outside are upon the slop-water system, no further amount need be calculated. The amount of *fæces* Parkes puts down as averaging $2\frac{1}{2}$ ounces per head per day, and of urine about 40 ounces. There may in certain houses be an addition to this liquid refuse in the shape of drainage from stables, cow-houses, and carriage washing, and in towns from slaughter-houses and from certain trades, but as the water for this purpose is usually supplied by meter, a general average quantity can be readily ascertained.

While it is very desirable to separate the rainfall from the sewage to the fullest possible extent, in order to lessen the difficulties of dealing with the sewage at the outfall-works, it is obvious that some proportion must be conveyed by the house-drain, unless it is feasible to provide two systems of conduits. In country places there is generally little difficulty in doing this, but in towns the prevalence of two systems is not an unmixed blessing; unless the methods of

supervision leave nothing to be desired, from time to time connections are apt to be made of soil-drains to rain-water drains, and the presence of two systems must ultimately lead to confusion. It is in many cases, however, quite possible to separate the water falling in the fronts of houses from the sewage, and it must be remembered that in those districts where the Private Street Works Act, 1892, is adopted, councils have power to compel the owners to provide two sewers for sewage and surface-water respectively (Sec. 9, sub-sec. 1).

It may be assumed that at least the **rain-water from the back portions of roofs**, and that which falls on paved and flagged surfaces of yards and areas, must be provided for in the system of sewage-drains. The following table is often quoted as showing the depth of rainfall per hour flowing off various surfaces, for which provision should be made in sewers:—

TABLE XXIV.
FLOW OF RAINFALL PER HOUR FROM VARIOUS SURFACES.

| | Inches in depth. |
|---|---------------------|
| From roofs, | .5 |
| From flagged surfaces, | .2 |
| From paved surfaces, | .1 |
| From gravel surfaces with clay subsoil, | .05 |
| From gravel surfaces with gravel or chalk subsoil, | .01 |
| From meadows or grass plots, | .02 |

The average number of days per annum, upon which .5 of an inch of rain falls in the 24 hours, is 6, and 1 inch or more falls upon one or sometimes two of those days, and very frequently that quantity is discharged in a very short space of time. On p. 128 of Symons's *British Rainfall, 1884*, the following **extremes of rainfall in the British Isles** are recorded:—

| | |
|----------------------------|-----------------------------|
| 0.55 inch in 5 minutes. | 1.50 inches in 45 minutes. |
| 1.10 inches in 15 minutes. | 1.80 inches in 60 minutes. |
| 1.25 inches in 30 minutes. | 2.20 inches in 120 minutes. |

It is by no means rare (and it is within my own knowledge) to have a fall of 1 inch in half an hour. So that it will be safe to take an extreme case of, say, 2 inches falling in 1 hour. As it is usually impossible to pass this rainfall away by any other method than the drain, or to have any system of relief or storm-overflow drains, the house-drain must serve this purpose, and although some small portion may by soakage and evaporation not reach the drain, this portion—having regard to the impervious character of the surfaces of the roofs and yards, and the rapidity with which rain falls during violent storms—may be neglected. It used to be the custom to make an allowance also for a certain

amount of subsoil-water finding its way into the drains, the joints of which were purposely left open to facilitate its entrance, but joints which let water in, also let sewage out, and thus set up a dangerous condition of things by the pollution of the soil. The realization of this fact, coupled with the necessities of keeping out surface or ground water as far as possible, as referred to above, has led to drains being constructed with absolutely water-tight and air-tight joints, so that they may more efficiently perform their functions as conduits for sewage and foul waters, the speedy removal of which from the house and its precincts is one of the most essential conditions necessary to the maintenance of a healthy habitation.

Before laying down any code of regulations to ensure efficiency in a drainage system, it will be well to consider what are **the dangers and defects to be avoided**. The removal of domestic sewage is either effected by the water-carriage system, or by the conservancy system, which includes "privy-midden" closets, "pail" and "earth" closets. In the conservancy system, the fæces are kept out of the drains, which receive only the foul waters of the house. Very many people remain under the impression that, with a conservancy system, the question of drainage is of little importance, as they imagine that what the drain has to convey away is not of a dangerous character; but when we come to add to the ordinary waste waters of the house, the chamber-slops containing the urine, and in some cases the sewage from stables, cow-houses, and piggeries, it will be at once seen that we have a highly-complex liquid, and one which differs in its impurity only to a slight degree from the sewage containing also the discharges from water-closets.¹

Decomposition of sewage begins directly it passes into the drain, and may be said to reach its most active stage after the lapse of from three to four days, though in some states of the atmosphere the time is longer. Often very fetid substances are given off, and the following gases have been traced:—Sulphuretted hydrogen (H_2S), marsh gas (CH_4), bicarburetted hydrogen (C_2H_4), carbonic acid gas (CO_2) in excessive quantities, and ammoniacal gas. Having regard, therefore, to the dangerous character of sewage, it is important that the system of drainage, devised for removing it from the precincts of the house, shall be free from defects attributable to bad design, unsuitable materials, and careless workmanship.

The only drainage-system to many houses consists of a series of **stone or brick drains** of rectangular form, the materials being laid with open joints. While this type of drain may be the most suitable for drying the ground, it is

¹ See Vol. II., Section IX., page 4.

the most unsuitable for conveying sewage, which is invariably deposited upon the flat bottom, and percolates through the open joints into the surrounding soil, and the gases given off may be drawn through the soil into the house, or escape by way of the connections and imperfect sanitary appliances into the house. In many instances, this particular type of drain was originally laid down for the purpose of draining away the water found in the site, and is frequently found under basements of houses. From time to time, as sanitary appliances have been added to the house, the several waste-pipes have been connected to the drain, until gradually it has become filled with sewage-deposit, and a huge underground reservoir of sewage-gas is formed.

Another very objectionable type of drain is that formed of egg-shaped earthenware pipes with "butt" joints,—that is, an open joint without any overlapping sockets,—which allow the percolation of the sewage into the soil and the escape of gas; and, in addition, this want of joint facilitates deposit in the pipe by reason of the readiness with which any floating object gets locked in the opening between the pipes, and so forms an obstruction.

The material now most generally used for house-drains is **the circular socketed earthenware pipe**, but it will not do to assume that, because the drain is of this material, it is therefore quite right. A drain formed with such pipes may be extremely defective, because of their unsoundness, bad shape, and want of proper jointing, as well as on account of imperfect foundation, and not being laid true to the gradient or alignment, any of which defects will surely cause the drain to become a nuisance.

One of the greatest defects to be avoided is **bringing a drain inside a house**. It is rare indeed that any necessity arises for such a course, yet it is very common to find basements plentifully supplied with gullies, and investigation reveals that the only purpose they serve is to carry away the water used in washing the floors. Here we have a communication between the interior of the house and the sewer, the only check being the trap in the gully, which may or may not be an efficient one; and even if it is so theoretically, it must be remembered that it will lose its seal by evaporation, and that the water standing in it will absorb the gas coming from the drain, and give it off into the house. It is a common thing to receive an assurance that all the drains about a house are properly trapped, the special faculties of a trap being understood by some people to be almost supernatural; but an interior trap, however good in form, without external disconnection, can never be anything but a defect, and any system which includes waste-pipes, whether trapped internally or not, which have a direct connection with the drain, is one to be avoided.

In many districts, it is the usual practice **to connect the rain-water pipes directly with the drains**, under the assumption, possibly, that they will serve as ventilators. This is a very mischievous practice, and cannot be too strongly condemned as one that is fraught with much danger to the public health. When the pipe is most required as a ventilator,—that is, when the air of the drain is displaced by the sudden rush of the water caused by a rainfall,—the air forced to the rain-water pipes is met by the column of water descending from the eaves, and is forced out in another direction. Again, not only is the position of the heads of rain-water pipes often adjacent to windows, so that the drain-air readily communicates with the house, but by reason of defective joints, which are very common, escape also takes place there at frequent intervals.

These are amongst the most common of the dangers and defects to be avoided in a drainage-system, apart from those met with in the sanitary appliances and fittings in the house. Those arising from the discharge of the sewage into cess-pools will be found described in the section dealing with “Sewage-Disposal”; and the disadvantages caused by a direct connection of the house-drain with the public sewer, are dealt with in the subsequent chapter relating to “Ventilation, Disconnection, and Inspection”.

One of the most important conditions to be complied with, in order to ensure a healthy habitation, is the necessity of having **a system of immediate and perfect sewage-removal**, in order that the air and soil may not be contaminated with excreta, nor the water-supply fouled by either direct or indirect contact with the sewage or its emanations. Where the sewage has been removed from the premises and delivered into the public sewer, this may be said to be accomplished, as it is then the duty of the Local Authority to convey it to some convenient spot, where it can be dealt with so as not to be a nuisance or injurious to health. In the absence of any system of public sewers, the sewage will require to be disposed of by one or other of the methods subsequently described in the section on “Sewage-Disposal”.

In order that these conditions may be complied with, and the drainage-system perform its proper functions, its conception and design must be influenced by **certain essential conditions**, and upon the degree of perfection with which these principles are carried out depends the efficiency of the system. The essential conditions necessary to be observed are:—

1. *Removal of Sewage.*—The sewage must be rapidly removed from the building and its precincts, and the drains be “self-cleansing”, so that there is no stagnation or collection of deposit in them.

2. *Surface and Subsoil Water.*—Wherever practicable, the surface and subsoil water must be conveyed away in separate drains.

3. *Line of Drains.*—All drains must be laid in straight lines from point to point, with true gradients.

4. *Turning.*—All turning must be done in “manholes” or “inspection-shafts”, which must be placed at every change of direction or gradient.

5. *Drains to terminate outside house.*—Drains must not pass to the inside of houses, but end at an outside wall.

6. *Drains under Houses.*—Drains must never pass under buildings when it can possibly be avoided, and in towns where drains have to be carried through the house from back to front, special precautions must be taken.

7. *Separation of Branches.*—All important branches must be independent, and concentrated in a turning-chamber, and all branches be as short as practicable.

8. *Inspection-chambers.*—The drains must in all parts be readily accessible for the purposes of examination, testing, and cleansing.

9. *Water-tightness.*—The best materials must be used and skilled labour employed to ensure the drains being water-tight, so as to avoid pollution of the soil and air, and the admission of subsoil-water.

10. *Size.*—Drains must not be larger than necessary for the maximum duty they may have to perform, as the larger the drain in proportion to the quantity of sewage passing through it, the less is the power of the sewage to carry solid matters along, and *vice versa*.

11. *Falls.*—The falls of drains must, wherever possible, be sufficient to produce a self-cleansing velocity for the small amount of sewage that is usually discharged through them, apart from rainfall.

12. *Depths.*—Excessive and unnecessary depths must be avoided. Special means must be taken to effect the change of levels in drains.

13. *Disconnection of Main Drains or Sewer.*—The air-communication between the public sewer or cesspool, and the house-drain, must be severed by means of an intercepting trap fixed in a manhole or shaft.

14. *Disconnection of Long Branches.*—All exceptionally-long branches must, in like manner, be severed from the main house-drain.

15. *Ventilation.*—The drains must not terminate in a dead end, but be amply ventilated by openings so as to create an undiminished current of air through them.

16. *Inlets to be trapped.*—All inlets to drains must be properly trapped, with the exception of those used for the purpose of ventilation.

17. *Wastes to discharge in the open air.*—All waste-pipes from sinks of every kind (except house-maid's slop-sinks), baths, lavatories, and other appliances from which foul matter is discharged, and all rain-water pipes, must deliver over gullies placed in accessible positions and connected with the drains outside the house.

18. *Flushing.*—If the available fall is not sufficient to produce a "self-cleansing" velocity in the drains, provision must be made for regular and frequent flushing. When the discharge of sewage into drains is only intermittent, and not sufficient to prevent deposit in them, an automatic flushing tank should be fixed at the head.

19. *Materials.*—The materials must be the best of their respective kinds, and where the local conditions render it necessary, extra precautions must be taken in the selection of them, and all appliances of a special type should be tested in order to ascertain if they will satisfactorily perform the functions required of them, and only those should be selected that are the least likely to get out of order through the carelessness of a workman, or the neglect of those under whose care they are placed.

20. *Workmanship.*—To ensure sound sanitary work, the best skilled labour must be employed under the supervision of a competent expert, and all completed work must be carefully and adequately tested before being passed.

These conditions will apply to the design of every system of drainage, from the cottage to the mansion, in a greater or less degree, according to the requirements of each, dependent upon the number and nature of the sanitary appliances in use for carrying off the foul water, &c. In the cottage, the only internal sanitary appliance is the kitchen sink, and to design a scheme of drainage to carry away the foul water from this, as well as the rain-water from the roof and back-yard, is not a very difficult matter, so long as the cottages are built singly or in pairs.

When, however, we have to deal with houses in rows, certain difficulties present themselves, difficulties not requiring any special engineering to overcome, for they arise solely from recent judicial interpretations of the words "**drain**" and "**sewer**", as defined by Sec. 4 of the Public Health Act, 1875. To the ordinary mind, it has hitherto been always understood that those pipes which are within the premises belonging to the house, such as the yard or garden and the passage common to several houses, whether built in rows or otherwise, and which have been cleansed and maintained by the owners, were *drains*, as distinguished from the *sewer* in the adjacent street or road, which conveys the sewage from the several houses on either side.

All these long-established notions have been swept away by the decision, in the Halifax case of *Travis v. Uttley* (Court of Appeal, Nov. 27, Dec. 4, 1893, —*vide* Law Reports, 1894, I. Q. B. D., p. 233); though there have been several cases since that date, the decision remained unchanged until the summer of 1897, when in the Queen's Bench Division, before Justices Cave and Ridley, the case of *Seal v. Merthyr-Tidfil Urban District Council* was heard, when, after reviewing all the facts relating to the case, Mr. Justice Cave, in summing up, said, "What is a 'private drain' within the meaning of this Section? It appears to me to apply to a drain constructed on private premises to which the public have not access. 'Private' is to be taken in that sense; that is, as being a drain which is private, and constructed on private land,—on land which is not open to the public." This further decision, together with the different interpretation of the word "drain" in the Public Health Act, 1890 (which is an adoptive act), renders the whole position most confusing and unsatisfactory.

According to the Public Health Act, 1875, a "sewer" is a drain "into which the drainage of two or more buildings or premises occupied by different persons is conveyed". Thus, in fig. 307, which represents the drains from the backs of four houses communicating with a 9-inch pipe, this pipe is, according to the definition, a "drain" from A to the junction of the branch-drain from B, while beyond this point it is a "sewer". The subject will be further discussed by Dr. A. Wynter Blyth, who is a barrister as well as a doctor, in the Section on "Sanitary Law", and for additional information reference may be made to the very excellent paper, read before the Sanitary Institute, on "Combined Drainage", by J. F. J. Sykes, M.D., D.Sc., and W. N. Blair, Assoc. M. Inst. C.E. (*vide* Vol. XVI., Part II., *Journal of Sanitary Institute*, p. 274), and also a paper read by Mr. R. Godfrey, Assoc. M. Inst. C.E., before the Association of Municipal and County Engineers (*vide Proceedings*, Vol. XXI., p. 75).

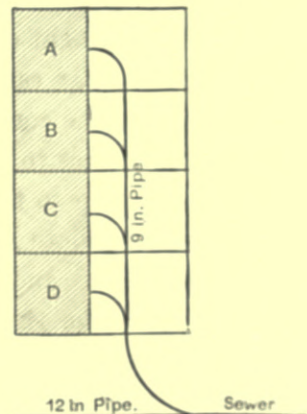

Fig. 307.—Diagram illustrating the terms "Sewer" and "Drain".

Apart from the legal difficulties caused by carrying the main drain through the back-yards, as shown in the diagram, there are others, which may and do occur, caused by what we may call economical promptings. Taking again the block ABCD, the proper position for the main drain is in the passage as shown by double lines, the branch drain from each sink being carried through the yard belonging to each house; but some builders, with a desire to save the cost of repeating the portion of the branch drain marked x x, lay the main in the

position shown by the double dotted lines, and the branches passing from one yard through the next. If, at any time after the houses are built, any one of them should be sold, the viciousness of this system of drain-planning would present itself, should there be any stoppage in the drain. Suppose the house D

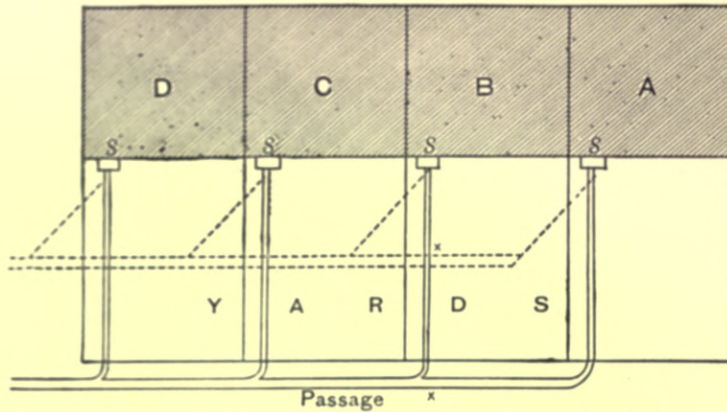

Fig. 308. — Drainage for a Block of Four Houses.

to have been sold separately, and that a stoppage occurs at the junction of the branch from c; this being upon the premises of D, c has no right of entry to repair, and should D be unwilling to assent to such entry, not only would c be inconvenienced by the stoppage, but A and B also, who

might too be different owners. Such difficulties as are here presented are swept away by the Halifax case, so far as relates to D and c, but if the decision in the Merthyr case is the correct one, then they will remain. It is an excellent rule in all circumstances to keep the drains required for any house solely within the premises belonging to that house, until the public street or passage is reached.

The plans in Plate XIV. show a well-arranged house having all the necessary sanitary appliances, and it is our purpose to **design a system of drains** that will carry away all the sewage, waste-water, and rain-water, not only in such a manner as will comply with the conditions already laid down, but that will also be economical in construction. Many systems, while doing their work satisfactorily, are complicated by an excessive number of unnecessary drains, and have been costly to construct by reason of the routes chosen, or from the depths at which the drains have been laid. In the designing of the position for the various sanitary appliances, their concentration should be aimed at so as to reduce the number of branch drains as far as possible consistent with efficiency.

If we examine the basement plan, we find that there are sinks in the scullery from which the wastes will have to be carried away; this will necessitate the drain being laid deep enough to drain the gully, which must be placed in the area at E to receive the wastes from the two sinks. This should be a flushing-rim grease gully, which may be cleansed from a flushing-tank fixed at E. If we refer to the first-floor plan we shall find a dressing-room over the scullery, so

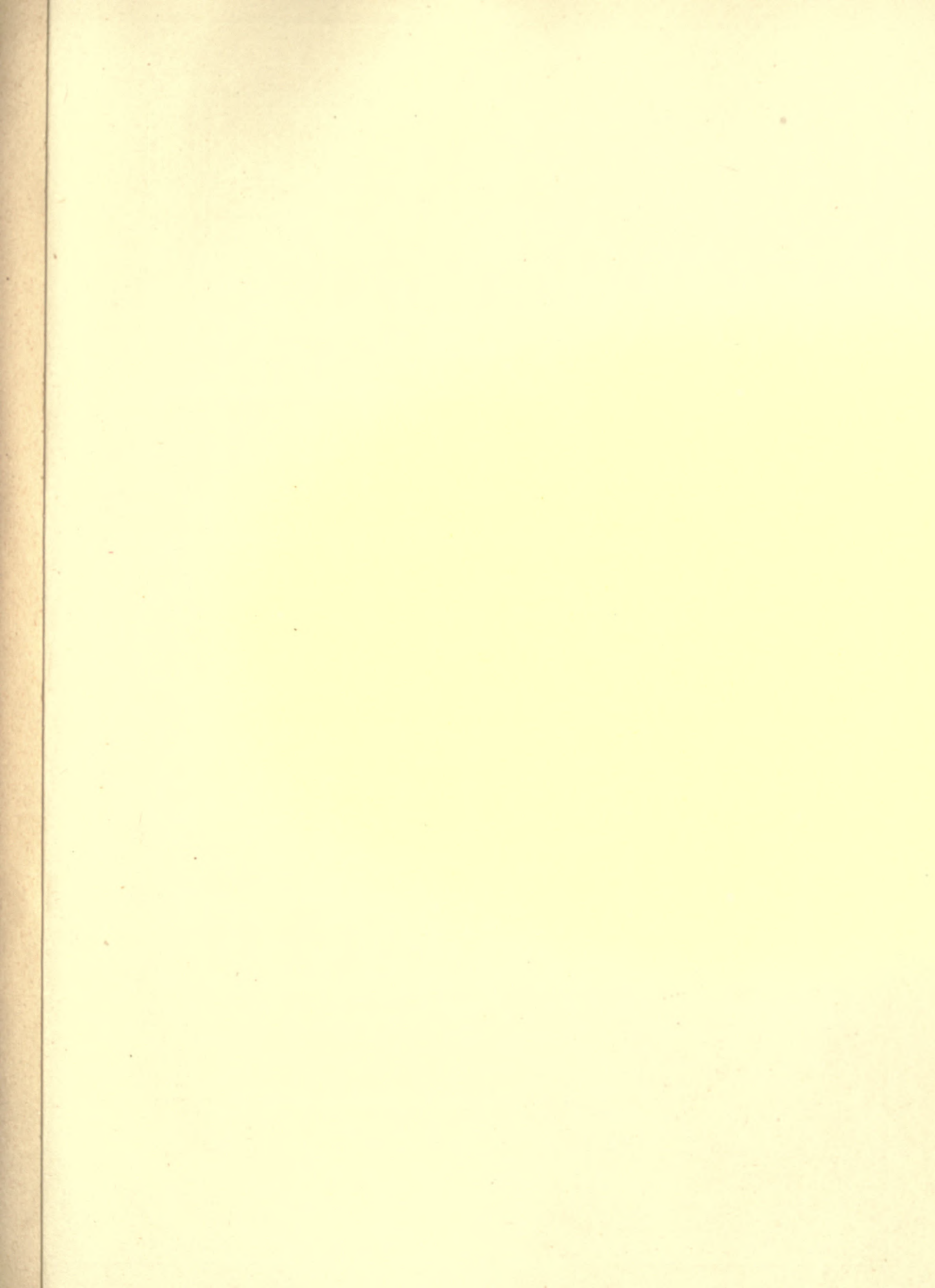

the waste-pipe F from the lavatory basin may be carried down to feed the cistern, as also that from the overflow N from the cistern fixed on the second floor. In the same area at A is a Sykes's gully with three unions, one for the waste from the clean-water sink D in the scullery, another for the waste from the foul-water sink in the scullery, another for the waste from the bath at B on the first floor, and from the lavatory basin at C in the bath-room.

The two branch drains from A and E will join in manhole No. 5, and from this will be laid a drain to the rain-water pipe R, with a through connection to an upcast ventilator at v. The drain from the south side of the house will enter the intercepting chamber at P¹.

On the west side of the house there are no waste-pipes from the basement, but there is the servant's w.c., and if we examine the plans closely we shall find that the cloak-room w.c. and the w.c. on the first floor are immediately over this, so that one soil-pipe H will serve for the three closets. At J is the waste-pipe from the cloak-room lavatory. These two branch drains will form a junction with the main drain in manhole No. 2, into which the branch from the rain-water pipe at the corner R may be connected.

At the angle where the main drain is required to turn, so that the branch drains from the north side may be picked up, a manhole (No. 3) should be formed having a suitable curved channel. On this side of the house, on the ground-floor, there is a maid's pantry, in which is a sink K for washing china, glass, silver, &c., and immediately over this room on the second floor is a house-maid's closet with slop-sink L. As this is the head of the main drain, it is desirable that there should be a flushing-tank connected with it; this can conveniently be done by dividing the manhole No. 4 into two chambers, the lower one receiving the branch drain from L, and in the upper fixing a syphon flushing-leg, utilizing the waste-water from K and the rain-water from R R for flushing purposes. The pipe at L, being constructed as a soil-pipe, will serve as a ventilator.

The various sanitary appliances denoted on the plan, together with the methods of designing and constructing the drain, and a consideration of the materials to be used, are referred to in subsequent chapters.

The illustration just described will serve for most types of houses, modifications being introduced to suit the special circumstances met with in each case, provided the principles are not departed from. In the arrangement of town houses, and especially in London, it is not, however, always possible to carry the drains entirely outside, as usually there is no access to a back road, so that the drain must be carried under the house from back to front. The best method of

doing this is by using iron pipes, and following the directions as to ventilation laid down in the Model By-laws (see No. 62), but there are also other means which will be subsequently pointed out.

CHAPTER II.

THE SIZE AND CAPACITY OF DRAINS.

In times gone by there seems to have been no rule, beyond the rule of thumb, for determining the size of house drains, if one may judge from the size of those so often discovered about old houses, where it is not at all uncommon to find a stone drain 4 feet high by 2 feet wide, quite large enough for a man to traverse easily. It is difficult to determine why they should have been constructed so large, but as they are usually open-jointed, the only inference is that they were intended also to serve the purpose of drying the ground by draining off the subsoil-water.

Even in these days, when glazed circular stoneware pipes are almost universally used, it is far too common to find them much too large for the purposes they have to fulfil, and I am acquainted with districts where the local sanitary authorities demand that a drain serving two houses shall be at least 9 inches in diameter. So many people persuade themselves into the belief that a drain is bound to get stopped up sooner or later, and that by adopting a large pipe they are erring on the safe side. If a pipe is securely and firmly laid, and is of sound materials and kept to the gradient, it will be as true inside as the barrel of a rifle, and any stoppage that may occur will be found to be due to accidental circumstances; if, on the other hand, the pipes are of inferior materials, insecurely and irregularly laid, and also imperfectly jointed, then, of course, they will in a very short time become made up. This imperfect class of work is so common, that it is easy to understand why there are so many upholders of the large-sized pipes. If, however, these people will only consider that, for a great part of the day, only a very thin stream of dirty water is flowing through the drain, and that if it is spread over a large surface—as it must be in the larger pipe—there will be a retardation of the flow, consequent on the increased friction from the surface of the pipe with which the stream is in contact, they will see that the solids brought down will be deposited, and stoppage will ensue. Again, the area of the pipe not taken up by the stream is necessarily filled with

foul air, which increases the difficulties met with in providing means of ventilation.

By ascertaining the number of inhabitants of the house, care being taken to fix the probable maximum number so as to include visitors, it is easy to calculate what will be the **probable amount of sewage** to be conveyed away. It must be remembered that domestic operations do not extend over more than sixteen hours of the day, and for long intervals in that time no waste-water is being discharged from the house; on the other hand, there are periods when the discharge is rapid. Probably the two hours immediately after breakfast will contribute at least half of the total quantity discharged during the day. The most extreme case, however, will be at the time the baths are discharged; assuming that 45 gallons of water are used in the bath, then the waste would be equal to a discharge of 15 gallons per minute, and in addition there might from other sources be discharged a further 5 gallons. Beyond this domestic sewage, provision may have to be made for the waste-water from laundries, carriage washing, the drainage from stables and cow-houses; the maximum from these sources would be at the time when a pail of water was being discharged over a carriage, and if we allow 2 gallons for this, we have a possible total of 22 gallons discharged in any given minute.

We have also seen what is the **possible depth of rainfall** that will have to be carried away by the drain, and having limited the area as much as circumstances will allow, it is a very simple matter to calculate the maximum quantity per minute for which accommodation must be provided in the drain. It must be borne in mind too, that this excessive quantity of rain may have to be carried away at the precise moment when the greatest quantity of water is being discharged from the house,—that is, when a bath is being let off,—so that these two quantities must be added together to give us the total for which provision has to be made. Assuming a rainfall equal to 2 inches per hour, this will give a discharge of 2.5 cubic feet per minute from 100 square yards. From these figures, it is a simple matter to calculate the quantity from any required area.

The total maximum quantity of sewage and rainfall being ascertained, the **size of drain required** to carry it away can be fixed by determining the amount of fall which is available, and by working out the gradient. For house drains a velocity of not less than 3 feet per second should be obtained, as this will serve to remove easily and rapidly from the premises the sewage and the solids carried along with it. This velocity is called a "self-cleansing velocity", and has been fixed upon after a long series of experiments on the flow of water, carried out by Wicksteed, Beardmore, and other well-known hydraulicians. In

Beardmore's *Manual of Hydrology*, it is stated that the following velocities have these effects:—

| | | |
|--------------------|------------------|---------------------------|
| 30 feet per minute | will not disturb | sand with clay and stone. |
| 40 feet per minute | will sweep along | coarse sand. |
| 60 | " | " " fine gravel. |
| 120 | " | " " rounded pebbles. |
| 180 | " | " " angular stones. |

Bottom velocity (which imparts the greater motion) differs from the mean velocity in the ratio of .80 to 1, or four-fifths. The greatest *discharge* from a circular pipe is when it is not quite full,—that is, when the flow occupies rather more than fifteen-sixteenths of the area of the pipe,—and the greatest *velocity* occurs when it occupies thirteen-sixteenths.

The **velocity of the flow** depends upon the inclination of the pipe, and what is called the hydraulic mean depth, which is the cross-sectional area of the stream in square feet, divided by the wetted perimeter in lineal feet, the wetted perimeter being that portion of the surface of the pipe which is in contact with the stream. For instance, in fig. 309 the wetted perimeter would be the length ACB,

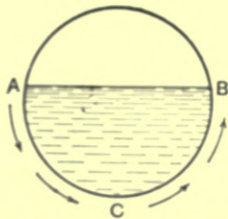

Fig 309—Section of Drain, illustrating the "Hydraulic Mean Depth".

and the sectional area of that portion of the pipe which is filled up to the horizontal line AB, divided by the arc ACB, will give the hydraulic mean depth. When the inclination of a pipe remains the same, the greater the hydraulic mean depth the greater will be the velocity. The friction between the particles of water and the surface of the pipe influences the velocity, and this is a factor which has not hitherto received as much attention as its importance deserves.

The amount of this friction will be governed more or less by the excellence of the glazing, and freedom from roughness and obstructions on the surface, and also by the accuracy with which the joints are made, as resistance to the flow would be caused by one pipe projecting slightly over the one next above it. It is clear, therefore, that the better the finish of the pipe, and the more accurately it is laid and jointed, the higher will be the velocity, and consequently the greater the discharging capacity.

While the velocity of a pipe should not be less than 180 feet per minute, it is not an advantage to have **excessive gradients**, especially in branch drains, because the excessive velocity so produced would, in times of light discharge of wastes from the house, cause the liquids in the sewage to part from the solids, and these would be left behind, decomposing in the pipe until the stream was sufficiently strong to carry them along. There is no reason why steep gradients

should be adopted, as, by laying the pipes in the manner which will be hereafter pointed out as necessary to effect a change of level, it is very simple indeed to adhere to the self-cleansing gradients. These may be very easily remembered by means of Maguire's decimal rule. For 4-inch, 6-inch, and 9-inch pipes, the figure of the diameter multiplied by 10 gives the gradient, thus:—

| |
|---|
| A drain 4 inches in diameter must have a gradient of 1 in 40. |
| " 6 " " " 1 in 60. |
| " 9 " " " 1 in 90. |

For good materials and workmanship these are approximately correct, as will be seen by reference to Table XXVI., but when greater accuracy is important, resort must be had to a selected formula.

In order to ascertain the velocity of the flow of water through pipes, numerous experiments have been made in all countries under all sorts of conditions, from which formulas have been compiled and published, many of which are very well known to engineers. That of Weisbach is the one used in the tables published by *The Surveyor*, and almost all that are recorded will be found in the little pocket-book issued by Mr. Albert Wollheim, A.M.I.C.E., called *The Sewerage Engineer's Note-book*. For a long time past the one most generally used in this country has been Eytelwein's, which has the merit at any rate of being easily remembered, and not demanding too great a mathematical strain in its solution, as will be readily gathered; it is

$$V = 55 \sqrt{R \times 2H},$$

where V = velocity in feet per minute.

R = hydraulic mean depth in feet.

H = fall in feet per mile.

55 = a constant.

A Swiss engineer, Kutter, has introduced a formula which includes a coefficient for roughness, varying according to the nature of the materials used in the channel, and this has been somewhat reduced and simplified by an American engineer, P. J. Flynn. Mr. Wollheim in his *Note-book* adopts Chezy and Eytelwein's formula—

$$V = C \sqrt{R \times S},$$

where V = velocity in feet per second.

R = hydraulic mean depth in feet.

S = slope = $\frac{\text{inclination of water surface}}{\text{length of channel}}$.

C = a co-efficient determined by experiment.

The value of $C \sqrt{R}$ will vary according to the co-efficient of roughness which is

adopted, and for glazed stoneware pipes where the condition of the surface is fair, this will be .013, and then the values of $C\sqrt{R}$ will be—

for 6-inch pipes flowing full, 24.60,
for 9-inch pipes flowing full, 34.00,

and the value of \sqrt{S} may be ascertained from the following table (P. J. Flynn) according to the gradient required. S = sine of angle of inclination = fall of water-surface in any distance divided by that distance.

TABLE XXV.
VALUES OF \sqrt{s} FOR ALL GRADIENTS FROM 1 IN 4 TO 1 IN 90.

| Slope. | \sqrt{s} | Slope. | \sqrt{s} | Slope. | \sqrt{s} | Slope. | \sqrt{s} |
|--------|------------|---------|------------|---------|------------|---------|------------|
| 1 in 4 | .500000 | 1 in 26 | .196116 | 1 in 48 | .144337 | 1 in 70 | .119524 |
| " 5 | .447214 | " 27 | .192450 | " 49 | .142857 | " 71 | .118678 |
| " 6 | .408248 | " 28 | .188982 | " 50 | .141421 | " 72 | .117851 |
| " 7 | .377978 | " 29 | .185695 | " 51 | .140028 | " 73 | .117041 |
| " 8 | .353553 | " 30 | .182574 | " 52 | .138676 | " 74 | .116248 |
| " 9 | .333333 | " 31 | .179605 | " 53 | .137361 | " 75 | .115470 |
| " 10 | .316228 | " 32 | .176777 | " 54 | .136085 | " 76 | .114708 |
| " 11 | .301511 | " 33 | .174077 | " 55 | .134839 | " 77 | .113961 |
| " 12 | .288675 | " 34 | .171499 | " 56 | .133630 | " 78 | .113228 |
| " 13 | .277350 | " 35 | .169031 | " 57 | .132453 | " 79 | .112509 |
| " 14 | .267261 | " 36 | .166667 | " 58 | .131305 | " 80 | .111803 |
| " 15 | .258199 | " 37 | .164399 | " 59 | .130189 | " 81 | .111111 |
| " 16 | .250000 | " 38 | .162221 | " 60 | .129100 | " 82 | .110431 |
| " 17 | .242536 | " 39 | .160125 | " 61 | .128037 | " 83 | .109764 |
| " 18 | .235702 | " 40 | .158114 | " 62 | .127000 | " 84 | .109109 |
| " 19 | .229416 | " 41 | .156174 | " 63 | .125988 | " 85 | .108465 |
| " 20 | .223607 | " 42 | .154303 | " 64 | .125000 | " 86 | .107833 |
| " 21 | .218218 | " 43 | .152499 | " 65 | .124035 | " 87 | .107211 |
| " 22 | .213200 | " 44 | .150756 | " 66 | .123091 | " 88 | .106600 |
| " 23 | .208514 | " 45 | .149071 | " 67 | .122169 | " 89 | .106000 |
| " 24 | .204124 | " 46 | .147444 | " 68 | .121268 | " 90 | .105409 |
| " 25 | .200000 | " 47 | .145865 | " 69 | .120386 | | |

The solution of Kutter's original formula, or of the modification introduced by Flynn, is rather too complicated and intricate a process for ordinary application, and the formula recently devised by Mr. Santo Crimp, M.I.C.E., is much more simple for general use. It is the outcome of a long series of experiments, and approximates in its results very closely to Kutter's when the co-efficient of roughness in that formula lies between .012 and .013. Crimp's formula is as follows:—

$$v = 124 \sqrt{r^2} \sqrt{s}$$

where v = velocity in feet per second.

r = hydraulic mean depth in feet.

s = fall divided by the length.

For circular pipes running full or half-full this is equivalent to—

V = velocity in feet per minute.

D = diameter in inches = 48r.

I = inclination, or length divided by the fall = $\frac{1}{2}$,

Q = cubic feet discharged per minute when running full.

$$\text{Then } V = \frac{563 \sqrt[3]{D^2}}{\sqrt{I}}$$

$$Q = \frac{3 \cdot 072 \sqrt[3]{D^5}}{\sqrt{I}}$$

In the *Tables and Diagrams for use in Designing Sewers*, by W. Santo Crimp, M.I.C.E., and C. E. Bruges, A.M.I.C.E., will be found the velocities of all sizes of pipes for every gradient required, together with a table for calculating their values, and the use of these tables will be found of great service.

On reference to Table XXVI., it will be noticed that the hydraulic mean depth of a circular pipe is the same when the pipe is flowing full and half-full, being equal to one-fourth the diameter of the pipe, and that it is greater when flowing three-quarters full, but, as already pointed out, it will be greatest when the pipe is thirteen - sixteenths full.

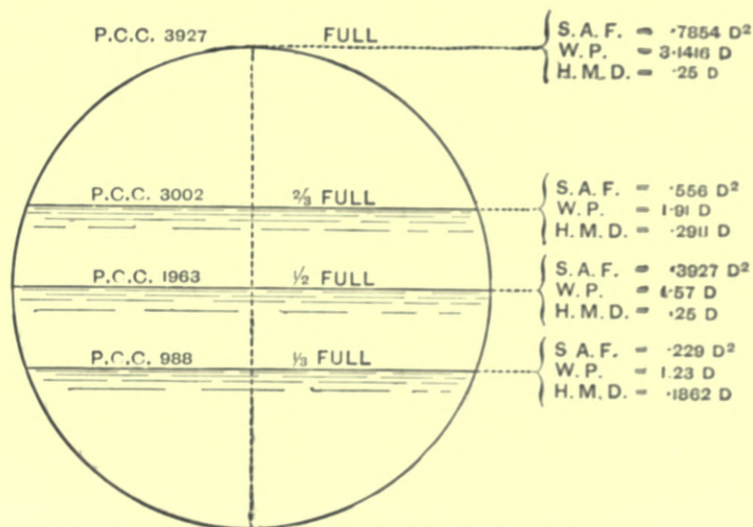

Fig. 310 — Data for Calculating Flow in Circular Sewers.

The discharge of water through pipes is calculated by multiplying the velocity in feet per second by the sectional area of the stream, thus—

$$D = V \times A,$$

where D = discharge in cubic feet per second.

On p. 150 of Slagg's book on "Sanitary Work", figures are given showing the carrying capacity of a circular sewer when running full, half-full, two-thirds, and one-third full, and the information is here exhibited in fig. 310.

- $\frac{2}{3}$ C.C. occurs at $\cdot 61$ H.
- $\frac{1}{2}$ C.C. occurs at $\cdot 5$ H.
- $\frac{1}{3}$ C.C. occurs at $\cdot 39$ H.

C.C. = carrying capacity; H. = height in feet; D. = diameter or width at springing in feet; P.C.C. = proportional carrying capacity (the width, D, at springing of the arch = 1 in each case); S.A.F. = sectional area of flow in square feet; W.P. = wetted perimeter in feet; H.M.D. = hydraulic mean depth in feet.

The efficiency of 4-inch, 6-inch, and 9-inch pipes at the respective gradients of 1 in 40, 60, and 90, and at various depths of flow, is shown in Table XXVI.

TABLE XXVI.
HYDRAULIC MEAN DEPTH, VELOCITY, DISCHARGE, &c., OF 4, 6, AND 9-INCH CIRCULAR DRAINS.

| | Proportion of Sectional Area occupied by the Flow. | Depth in inches. | Sectional Area of Flow in square feet. | H.M.D. in feet. | V. in feet per minute. | D. in cubic feet per minute. |
|-------------------------------|--|------------------|--|-----------------|------------------------|------------------------------|
| 9-inch pipes falling 1 in 90. | Full | 9 | ·442 | ·187 | 257·0 | 114 |
| | 3/4 | 6 3/4 | ·355 | ·225 | 291·1 | 103·9 |
| | | 5 3/4 | ·309 | ·216 | 283·4 | 88·1 |
| | | 4 1/4 | ·221 | ·187 | 257·0 | 57 |
| | | 3 3/4 | ·127 | ·138 | 210·0 | 26·8 |
| | | 2 1/4 | ·086 | ·109 | 179·9 | 15·6 |
| 6-inch pipes falling 1 in 60. | Full | 6 | ·19634 | ·125 | 240 | 47·1 |
| | 3/4 | 4 1/4 | ·158 | ·1508 | 272 | 42·4 |
| | | 3 3/4 | ·139 | ·1456 | 265 | 35·4 |
| | | 3 | ·09817 | ·125 | 240 | 23·5 |
| | | 2 3/4 | ·0573 | ·0931 | 196 | 11·0 |
| | | 1 1/4 | ·0384 | ·0733 | 168 | 6·4 |
| 4-inch pipes falling 1 in 40. | Full | 4 | ·0873 | ·0835 | 224 | 19·6 |
| | 3/4 | 3 | ·0762 | ·1006 | 254 | 17·8 |
| | | 2 3/4 | ·0618 | ·0970 | 247 | 15·1 |
| | | 2 | ·0436 | ·0835 | 224 | 9·8 |
| | | 1 3/4 | ·0255 | ·0621 | 183 | 4·6 |
| | | 1 | ·017 | ·0489 | 157 | 2·7 |

For other sizes of circular drains, the calculations will be simplified by the use of the following table:—

TABLE XXVII.¹
DATA FOR CALCULATING FLOW IN CIRCULAR DRAINS.

| Depth of Flow. | Area. | Wetted Perimeter. | H.M.D. |
|----------------|-------------|-------------------|----------|
| Full | ·7854 d^2 | 3·1416 d | ·25 d |
| 3/4 | ·632 d^2 | 2·095 d | ·296 d |
| | ·556 d^2 | 1·911 d | ·292 d |
| | ·393 d^2 | 1·571 d | ·25 d |
| | ·229 d^2 | 1·231 d | ·186 d |
| | ·154 d^2 | 1·047 d | ·147 d |

¹ This table is taken from *The Sewerage Engineer's Note-Book*, by Albert Wollheim, Assoc. M.Inst. C.E.

When it is required to ascertain the discharge of a pipe at any specific depth of flow, the following formula may be used:—

A = Sectional area of flow. r = radius.
 P = Wetted perimeter. d = diameter.
 H M D = Hydraulic mean depth. π = ratio between diameter and circumference, or 1:3.1416.

$$\text{H M D} = \frac{A}{P}$$

$$A \text{ (full)} = d^2 \times \frac{\pi}{4}, \text{ and } P \text{ (full)} = d \times \pi.$$

$$A \text{ of segment} = \frac{4 \cdot c}{3} \sqrt{(0.626 x)^2 + c^2}.$$

(Semi-chord c may be found by right-angled trigonometry).

$$\text{Or } A \text{ of segment} = \left(\frac{\phi}{180} \pi - \sin \phi \right) \frac{r^2}{2}.$$

Perimeter of segment = number of degrees \times .017453 radius.

Those not accustomed to the use of trigonometry may find the following method of solution of the problems somewhat simpler:—

K T = radius of circle.
 N O T = chord of whole arc.
 N Q = chord of half arc.
 O Q = versed sine (or depth of flow).
 N T Q = segment.

From $N K^2$ subtract $O K^2$, and the square root of the remainder = $O N = \frac{1}{2} N T$.

$N Q$ may be found from the following, — $N Q = \sqrt{O N^2 + O Q^2}$.

Wetted Perimeter $N Q T = (8 N Q - N T) \div 3$.

Area of Segment $N T Q = \frac{2}{3}(N T \times O Q) + \frac{O Q^3}{2 N T}$.

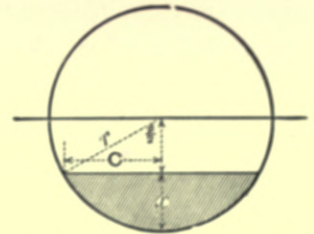

Fig. 311.—Diagram to illustrate Trigonometrical Calculation of the Discharge from a Circular Drain.

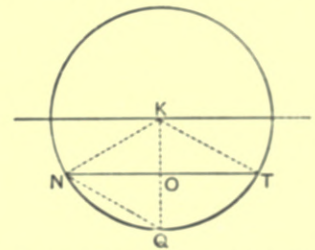

Fig. 312.—Diagram to illustrate Arithmetical Calculation of the Discharge from a Circular Drain.

CHAPTER III.

DRAIN-PIPES.

The chief points to be considered in the selection of drain-pipes are strength, durability, tightness, smoothness, nature of the material, shape, and method of jointing.

1. **Strength of drains.**—At first sight it would appear as if there is no need for strength, but the ground in which the drain is laid may not be very solid, and a slight subsidence may occur and thus bring a severe strain upon the drain; there is also the strain caused by the superimposed weight of the material replaced in the trench, which may be subsequently considerably increased if the level of the surface should be in any way altered. Again, there are certain districts,—such as in some colliery districts, where the workings are shallow and subsidence of the ground is continually going on, and in the brine-pumping districts, as the neighbourhoods of Northwich and Droitwich,—where sudden and severe strains are imposed upon the drains, rendering it extremely difficult to maintain them permanently sound. While in actual working there may be little risk of the drain being severely tested, it does sometimes occur that an exceptional stoppage will cause a whole pipe to be filled with water at a considerable pressure. While a house is being built, the drain may have to stand some rough treatment; or it may pass through a wall, and the weight or settlement of the wall may cause unequal pressure. The material of which the drain is made should be strong enough to withstand these various strains.

To test the strength of a drain it is necessary to try it in various ways. In order to ascertain its resistance to *crushing*, cut a hole to receive the socket, and bed the pipe horizontally and evenly, then pack and fill up with sand, and apply a weight uniformly along the top. For resistance to *breaking*, support the pipe on blocks and apply a weight at the centre. For *internal pressure*, use the ordinary hydraulic press, great care being exercised, in screwing up the press, to close the end of the pipe so as not to strain or fracture the material, and the pipe must be set plumb up and level, and the plates travel in parallel lines; if very accurate results are required, this is a very delicate operation.

During the 1897 Sanitary Congress in Leeds a visit was paid to the works of the Leeds Fire-clay Company at Wortley; and at Messrs. William Ingham & Son's branch, an ordinary 6-inch pipe, taken haphazard from stock, was tested for bursting, and did not collapse until a pressure of 150 lbs. on the square inch

was reached. It is needless to say that such an extraordinary pressure would never be experienced in practice.

The weakest part of a pipe is at the closing up of the shoulder of the socket to the barrel, and at many works the sockets are put in by hand after the pipes are moulded; pipes thus made must necessarily be weaker than those made complete in one moulding.

Bearing in mind the strains to which pipes are subject in transit from the kiln to the trench, the proper place to apply a test for strength is at the spot where the pipes are delivered for laying.

2. Durability.—A drain will in all probability be alternately wet and dry, as the flow in it will be very variable; it will also be exposed to extremes of temperature, as the water may enter it at any temperature between freezing and boiling. On the outside, the chemical composition of the soil may affect the durability of the drain; while as regards the inside, the effect of the exceedingly-complex and ever-varying nature of the sewage cannot be ignored. The pipe has also to resist friction, and its inside surface must be sufficiently hard to do so. The bottom part, or "invert", as it is technically called, necessarily has to bear the greatest strain from these wearing influences, the most destructive of which are the particles of sand and grit which are continuously borne along with the sewage. In the case of large sewers, it is the universal practice to construct the invert of harder materials than the other parts of the sewer, but in a house drain this is impossible; therefore all parts of the interior must be sufficiently hard. It is possible, however, to furnish the interior of a pipe with a hard skin that will also give smoothness, and, in the case of iron, one that will afford a protection against rust.

The resistance of a pipe to abrasion may be tested by applying a loaded small section of the pipe to a revolving grindstone kept wet and clean, the diameter of the grindstone and the number of revolutions required to remove the glazing, or to wear away a definite thickness of the pipe, being recorded.

3. Tightness.—At one time little regard was paid to the tightness of a drain, either as regards the material itself or the method of construction. Fortunately, a very different standard of efficiency is now required. Whatever is put into a drain must be carried off without any loss on the way, in order that the subsoil under and around the pipe shall be kept free from contamination; and one of the necessities of modern sanitary construction is, that a drain must also be air-tight as well as water-tight, as the contents of a drain are liable to decompose and to give off dangerous gases.

The impermeability of a pipe may be tested by its capacity for absorbing water.

4. Smoothness.—It is evident that any want of internal smoothness would not only largely increase the tendency to deposit and the risk of actual choking, but the efficiency of the discharging capacity of the pipe would be reduced, by the roughness of the surface impeding the flow and causing the solid particles in the sewage to adhere to the bottom; it must not be forgotten that, even in house drains, solid substances of considerable size occasionally pass down,—such as pieces of floor-cloth and scrubbing-brushes,—and one of these, lodging against an accumulation of deposit, would quickly cause a complete stoppage of the drain. While it is not possible to have the interior of a drain as perfect as the interior of a long glass tube, still this is the ideal which the manufacturer has before his mind. Some materials, while otherwise suitable, have not this smooth surface, but can be made available by coating them with some other substance; this, however, is only efficient when the surface is so joined to the body as to be practically one with it, and continues to remain so.

To produce this glaze upon a fire-clay or stoneware pipe, it is usual to throw salt into the kiln during the firing, so that when the pipe is completely burnt, it has a highly-glazed surface, which practically renders the pipe impermeable except under extraordinarily-high pressure, and enables it to resist the action of whatever acids are present in the sewage, and also the abrasion caused by the silt and other bodies which find their way into drains.

5. Materials for drain-pipes.—Drain-pipes are most frequently made of earthenware, but cast-iron pipes are now coming into favour, as they possess certain advantages.

Earthenware pipes are now most generally used, and may be divided into *stoneware* and *fire-clay*. These materials, though in some respects different, are to a great extent similar both in properties and method of use. It is a common thing for drain-pipes to be specified as stoneware without regard to these differences, and for fire-clay pipes to be accepted as stoneware; it is, however, very difficult to define precisely where stoneware ends and fire-clay begins. The well-known Lambeth “stoneware” pipes are made from clays obtained from Dorset and Devon, and their peculiar excellence consists in the vitreous and impermeable body of the material. It is more tenacious than fire-clay, so that an equally strong and durable pipe is obtained with a thinner crust. The pipes are consequently lighter, which effects a small saving in carriage, and in handling the larger pipes. It is a significant fact that this clay, owing to its power of resisting the action of corrosive liquids, is extensively used for chemical apparatus.

More frequently, however, drain-pipes are made from the clays obtained from the coal-measures, and known as the “*fire-clay beds*”. These vary very much

in their density, porosity, and ductility, all of which qualities are severely tested in the various processes of pipe-manufacture. The raw mixture should be so prepared and pugged, as to be able when dry and fired to retain, with only a slight deviation, the shape imparted to it in moulding. The most essential features to be obtained in the finished material are toughness, tightness, impermeability, durability, and strength, and the clay should be so finely ground that the finished pipe shall possess a perfectly smooth surface throughout, the crust being thoroughly homogeneous and capable of resisting intense heat.

Analyses show that the composition of the clays from which the stoneware pipes are made, and that of the Wortley clay from which the Leeds pipes are made, are much the same, but the latter possesses a mechanical condition which renders the pipes less brittle.

A good pipe should be well burnt throughout its entire body, straight in the barrel, truly cylindrical when cut die-square, highly glazed over the whole surface; the interior should be free from blisters, clinkers, and other defects, and the pipe should ring sound when rapped with a hammer.

It is customary for **the crust of stoneware pipes** above 6 inches in diameter to be $\frac{1}{12}$ of the diameter in thickness, and that of fire-clay pipes to be $\frac{1}{16}$. The following table, containing various dimensions of pipes, will be found useful for reference:—

TABLE XXVIII.
DIMENSIONS OF EARTHENWARE DRAIN-PIPES.

| Diameter of pipe, | 4 in. | 6 in. | 9 in. |
|---|--------------------|---------------------|----------------------|
| Thickness of crust, { Stoneware, ... | $\frac{9}{16}$ in. | $\frac{11}{16}$ in. | $\frac{3}{4}$ in. |
| { Fire-clay, ... | $\frac{9}{16}$ in. | $\frac{11}{16}$ in. | $\frac{15}{16}$ in. |
| Depth of socket, | $1\frac{3}{4}$ in. | $2\frac{1}{2}$ in. | $2\frac{1}{2}$ in. |
| Weight of pipe, { $\frac{1}{12}$ diam., ... | — | — | $59\frac{1}{2}$ lbs. |
| { $\frac{1}{16}$ diam., ... | 17 lbs. | 30 lbs. | 54 lbs. |
| Number per ton, { $\frac{1}{12}$ diam., ... | — | — | 25 yds. |
| { $\frac{1}{16}$ diam., ... | 88 yds. | 50 yds. | $23\frac{1}{8}$ yds. |

The use of **cast iron** for the carriage of water naturally suggests its employment for the conveyance of that water when it has become converted into sewage, and if it is possible to make a joint that will withstand the pressure exerted by the water, the same joint will be effective in preventing any escape of sewage or sewer-gas. Cast-iron pipes used for the purpose of drainage, although not requiring to be so heavy or strong as water-pipes, should certainly be finished in the same way, in order to prevent the action of rusting both on

the interior and exterior. The mere mention, in a specification, of iron pipes without stating details is not sufficient, as builders would get very light ones, and even rain-water pipes, so that the consequences would be worse than the condition of things it was sought to remedy. There must therefore be rigid regulations with regard to size, weight, and finish. As the pressures in drains, even under accidental circumstances, are not particularly great, it is not necessary to use very heavy cast-iron pipes. They should in all cases be of the following dimensions and weight as a minimum:—

TABLE XXIX.
DIMENSIONS OF CAST-IRON DRAIN-PIPES.

| Length. | Diameter. | Thickness. | Weight. | Depth of Lead. | Weight of Lead in lbs. | Space in Sockets. |
|---------|-----------|------------|---------------------|----------------|------------------------|-------------------|
| 9 ft. | 4 in. | 1 in. | 1 cwt. 1 qr. 3 lbs. | 1½ in. | 2·14 | 2 in. |
| 9 ft. | 6 in. | 1 in. | 2 cwt. | 2 in. | 5·6 | 2 in. |
| 9 ft. | 9 in. | 1 in. | 4 cwt. | 2 in. | 10½ | 2 in. |

Iron pipes must be free from rough projections, and should be coated in some way to prevent oxidation from contact with the sewage. The composition best known and most commonly used is the varnish devised by the late Dr. Angus Smith. It is a compound of tar, pitch, and oil, into which the iron is dipped, both iron and solution being at a temperature of not less than 300° F. The solution dries into a hard glossy black skin, which resists, for a considerable time at any rate, the ordinary influences to which pipes are exposed.

Another class of pipe which is frequently used is the one known as the **glass-enamelled iron drain-pipe**. The skin is practically like glass, and of a clear yellow or brown colour. These pipes are made in 6-foot lengths exclusive of socket, and their weights are—for 4 in. 90 lbs., and for 6 in. 150 lbs.

The use of cast iron for pipes permits of much more forcible methods being adopted in **making the joints**, the plan usually adopted being to make a lead joint on the ordinary socket and spigot pipes, as shown in fig. 313. The depth of the sockets should be 4 inches, the inner 2 inches being first caulked with white spun yarn, and the outer 2 inches then filled with molten lead,



Fig. 313.—Joint in Cast-iron Drain-pipes.

care being taken to use sufficient lead in one running to complete each joint. Bends, traps, junctions, access-holes, and all the usual accessories as made for stoneware drains, can also be obtained for cast-iron drains, and can be fixed and jointed without difficulty.

6. Shape of drain-pipes. We have already laid it down that pipes must be perfectly cylindrical, but it must not be forgotten that the egg-shaped pipe, in condemnation of which we have already given sound reasons, still appears in the catalogues of some makers, but with sockets. Although this shape of pipe is theoretically perfect, in practice it does not answer for such small drains as are generally used for houses.

At the Sanitary Institute Congress held in Newcastle in 1896, a new form of pipe was introduced by Mr. Plummer, F.R.I.B.A., and as it is now upon the market, it will be well to call attention to it. Mr. Plummer was induced to bring out this design by reason of the results of certain experiments which he made upon 6-inch and 4-inch drains, connected with a w.c. having a 2-gallon flush; and owing to the amount of deposit left in the drain, he came to the conclusion that a

pipe having a more contracted invert would be more efficient for the purpose.¹ The form of pipe adopted by Mr. Plummer is shown in fig. 314, the radius of the

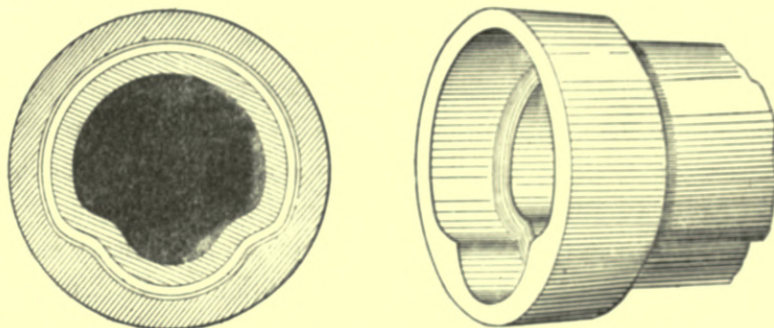

Fig. 314. — Elevation and View of Socket-end of Plummer's Drain-pipe.

invert being $1\frac{1}{2}$ inches. This shape follows the design of a sewer that is very common in large towns, especially in Paris, the invert being the channel for the dry-weather flow. While it has undoubted merits for exceptionally-large sewers, it remains to be seen whether in practice it will satisfactorily keep itself clean in house-drains, owing to the numerous bulky articles which find their way into them. It is claimed by the proprietors that solid matter in the drains is in continual contact with a stronger and deeper force of water than is the case with a circular pipe of similar diameter. The large upper diameter of these pipes provides for a sudden flood of water in the drain. The pipes roll into and remain in their correct position, and are not top-heavy or inclined to fall to one side, as in the case of the egg-shaped form. The

¹The results of these experiments will be found in Volume XVII., Part IV., of the *Journal of the Sanitary Institute*, and it will be well to compare these with the tests made by a committee of the Sanitary Institute on the flushing of water-closets, and published on the 1st November, 1893. It must be borne in mind, however, that, at Newcastle, the water-supply is in the hands of a company, who limit the flush to water-closets to two gallons. While the question as to whether two gallons are sufficient for the purpose is still a matter of opinion, it must not be forgotten that, in towns where the water-supply is in the hands of the sanitary authorities, the tendency is to increase the flush to three gallons.

advantages of strength are maintained by the circular form of socket, and the pipes can be connected with existing circular pipes and sockets of fire-clay or iron. Owing to the shape of the pipes, only those which are well formed can be truly fitted together, hence a misformed pipe must be discarded.

7. The jointing of drain-pipes.—For years subsequent to the introduction of earthenware pipes, the necessity for sound jointing was not sufficiently recognized, in many instances joints being purposely left open in order that the subsoil water might be drained away. It must not be forgotten that drains are of necessity laid quite close to the house, and at a shallow depth, so that in case of leakage the soil around and about the house gradually becomes impregnated with filth, and the vitiated air is drawn into the house by the heat therein. For this and other reasons which have already been pointed out, it is a sanitary necessity of the first importance that the drain must be absolutely water-tight and air-tight.

The material for jointing the pipes should in the first instance be in a soft or plastic condition, so as to be easily worked and made to completely fill the space between the spigot of one pipe and the socket of the other. The cheapest material for jointing pipes is *clay*, and this is unfortunately still largely used for the purpose in spite of continued protests by sanitary engineers. So long ago as 1878, Mr. Baldwin Latham drew attention to the danger of using this material, as being one of the worst that could be found for the purpose. In his well-known work on *Sanitary Engineering*, he says:—"We seek the most impervious materials wherewith to construct our sewers, and often spoil their effect by the indifferent manner in which we put the materials together. A soft yielding substance like clay is about the worst possible material that can be used for jointing pipes, as it must be clear that clay is liable to get washed out of the joints, both from the action of the water escaping from the pipe or the water flowing from the subsoil into the pipe. Apart from this, a soft yielding material when used for jointing, notwithstanding however perfectly the work may be performed, will lead to failure, as the weight of the earth covering the pipe causes the clay to be squeezed out of the lower part of the socket of the pipe, leaving an aperture in the upper part through which sewer air and sewage may escape, or water and sand be carried from the subsoil into the sewer. These serious defects in jointing not unfrequently lead to the disturbance of the line of pipes and destroy the regularity of their bed." Mr. De Courcy Meade, the City Surveyor of Manchester, in 1893, when he was the Surveyor of the Hornsey Local Board, in a report upon "Intercepting Traps and Water-tight Drains", likewise called attention to the dangers arising from the use of this material,

especially as "cracks will almost invariably appear in the clay filling, as it becomes dry and shrinks".

The cutting of socket holes for the purpose of giving the barrel of the pipes a continuous rest upon a firm foundation is very seldom performed except under closest supervision, nor is the puddle band carried completely round the pipe under the invert; and as much of this class of work is done by contract, or the labour performed by piece-work, it is hardly to be expected that drains so laid will continue water-tight.

The question of jointing earthenware pipes has always been one presenting great difficulty, and **the material used for jointing** is of great importance. It is generally *common lime mortar*, or mortar made of some more or less hydraulic lime or cement. For any purpose which implies contact with water, as a drain does, common lime is quite unfitted. It is readily worn away, and has not that closeness of texture needed to render it impervious both to water and gases. While *hydraulic limes* are of course better than common limes, their use and the saving supposed to be effected by them cannot be weighed with the advantage gained by using cement. Without making any comparisons between the relative merits of *Roman and Portland cement*, it should be admitted at once that a joint made with Portland cement and sand is a right one, subject to certain conditions:—there must be only one part of sand to 4 parts of Portland cement, and care must be taken that the sand is free from dirt, earth, or clay, and that it is sharp but not coarse in the grain. As ordinarily made,—that is, with improper sand and inferior cement or lime, and improper proportions,—the joint is quite as objectionable as the clay joint, not only from defects of material, but also of workmanship.

We have already pointed out that there is a space between the spigot and the socket of adjacent pipes when the spigot is driven home, and in **making the joint**, the spigot should be properly set up in the socket so as to get a true alignment of invert, and so that the whole space around the spigot may be evenly filled. Generally speaking, the labourer intrusted with this work takes care to plaster plenty of cement on the top of the pipe, where it can be seen, but a close examination will often prove that the invert is entirely bare, and that the spigot has not been set up. A reference to fig. 315 will show how pipes are generally laid, revealing the spigot in contact with the socket at the invert.

Another great objection to joints made in this way is that **the cement** is usually applied in too moist a condition, and there being nothing to resist its

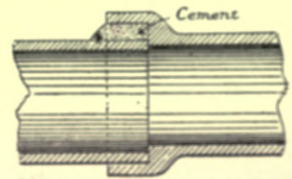

Fig. 315.—Faulty Drain-pipe Joint:
—Bad Alignment.

progress, it travels down to the invert, rises up through the joint, and there sets in a ridge, forming an obstruction to the flow of sewage, as shown in fig. 316. Jointing by this method is not to be commended, but if it is adopted there must

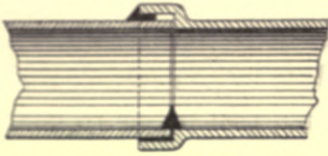

Fig. 316. — Faulty Drain-pipe Joint:—
Ridge of Cement.

be rigid insistence upon the proper setting up of the spigot in the socket, and true alignment of the inverts, and the pipe-layer, should he fail to accomplish this, must withdraw the pipe and procure one that will fit accurately. Care must be bestowed upon the proper mixing of the cement so that it will set easily without

displacement, which may be caused by blows from the men working in the trench or in the refilling of the earth.

The pipe-layer should always be provided with the tool which is known to the men as "**the badger**", with which to wipe out the inside of the joint after it is run. This tool may be formed of a disc of wood of slightly less diameter than

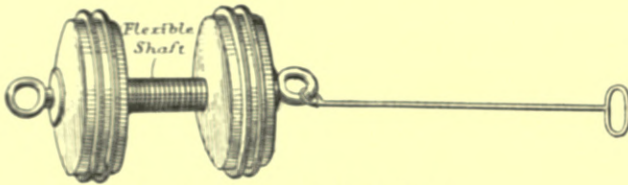

Fig. 317.—The "Loco" Drain-badger.

the pipe, having on its edge a narrow slip of india-rubber. The disc should be secured to a wooden haft of a length equal to the length of a pipe and a half. The disc should lie in the barrel of the pipe last laid,

and the pipe about to be laid should be passed over the handle and properly centred and set up; then after the joint is made, the badger should be pulled forward across the joint, from which it wipes away any protruding cement which has projected through in the interstices. Quite recently an improved badger has been introduced by Mr. Fred Lynde, A.M.I.C.E., which consists of two discs formed of hard wood edged with india-rubber, the discs connected together by a spiral steel spring which enables the tool to be drawn through bends. This badger is illustrated in fig. 317.

To make a sound cement joint, the space around the spigot, after centring and setting up the pipes, should be filled with strands of tarred gasket, which must be driven home to the rebate of the socket, the work being done with a proper caulking tool of hardest steel cranked for hand hold, with a flat face $1\frac{1}{8}$ inches \times $\frac{5}{16}$ inch. The band of tarred gasket will prevent any of the cement from passing through the joint, and, being impervious, is not liable to rot although in contact with the moist cement. To make the joint properly, a hole in the bottom of the trench should be made in front of each socket to give the joint-maker room to work in. The cement should form a fillet projecting beyond

the socket to a distance equal to the thickness of the socket, and be neatly bevelled off to an angle of 45° . This joint is shown in fig. 318. It is a most efficient one, and requires considerable skill and care, and although it costs more money than the somewhat loose and unsatisfactory method first described, it is well worth the extra expenditure. The cost of the tarred gasket is about 4*d.* per pound, and the weight required for a 6-inch pipe is $4\frac{1}{2}$ oz., and for a 4-inch pipe $2\frac{1}{2}$ oz.; the amount of cement required for a 6-inch pipe is $2\frac{1}{3}$ lbs., and for a 4-inch pipe $1\frac{1}{3}$ lbs.; the time expended by the pipe-layer in laying, driving home, centring, setting up, caulking, and pointing the pipe, averages for a 6-inch pipe $5\frac{2}{3}$ minutes, and for a 4-inch pipe $2\frac{1}{3}$ minutes. These times do not include any work about the trench, or in lowering the pipes, which would of course be common to all types of pipes.

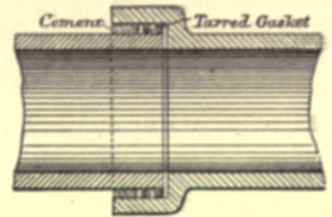

Fig. 318.—Drain-pipe Joint made with Gasket and Cement.

Fig. 319 shows the "Loco" self-centring joint. It will be seen that on the

socket are two lugs, C and D, on which the spigot rests, so as to bring the inverts true at the joints. The lugs prevent the insertion of tarred gaskin the whole way around the spigot, and as there is no provision made, as in Hassall's joint, for preventing the cement from coming up through the joint, a badger must always be drawn through the pipe for the purpose of wiping off the projecting cement.

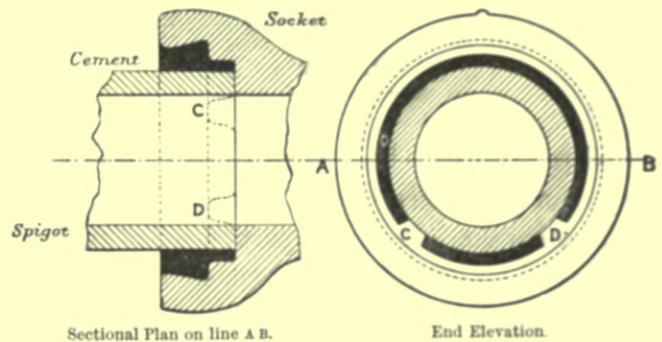

Fig. 319.—The "Loco" Self-centring Joint.

It will be seen that there are many difficulties to be overcome in forming a perfect cement joint. It is not surprising, therefore, that considerable attention has been given to this matter; the **patents for drain-pipe joints** that have been taken out within recent years have been very numerous indeed, but many of these, although displaying great ingenuity, have failed to meet with practical success. Some of them have been found wanting in important particulars; and it is not necessary to do more than just mention them, such as those designed to afford arrangements to facilitate inspection, including half-socket pipes, chairs and saddles, access-openings, butt-joint pipes with loose collars, ground joints, tongue-and-groove joints; other patents are for joints made by compressing

flexible materials in the socket, arrangements to secure firm bedding of pipes, and arrangements to secure truth of invert. **The special joints most generally used to-day** may be classed under three heads:—*first*, joints based on Stanford's principle; *second*, spigot-and-socket joints with provision for pouring-in liquid cement; *third*, screw joints.

Stanford's joint is the oldest of all special joints, and is still in the field. It was patented in 1873 by Mr. W. H. C. Stanford, and is shown in fig. 320. On

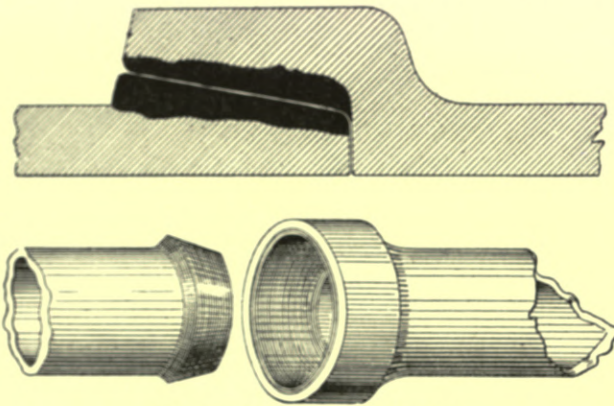

Fig. 320.—Stanford's Drain-pipe Joint.

the socket is cast a ring of asphalt, and a similar collar is cast on the spigot, the latter being tapered in order to admit of a small amount of adjustment in laying the pipes, and also a slight settlement without injury. In laying the pipes, both the ring and the collar require greasing so as to get the joint to fit more readily, and to prevent stripping the composi-

tion when the pipe is being adjusted to its position. As the patent has run out, any person can make this joint on ordinary pipes, the composition being formed of one part of clean sharp sand, one part of boiled tar, and one part and a half of sulphur.

Messrs. Doulton for some time have had a joint based very much on the same lines, which has culminated in the production of the joint known as "**the self-adjusting joint**", and which is shown in fig. 321. It is formed by the contact of two bands of composition cast on the spigot of one pipe and in the socket of the other pipe;

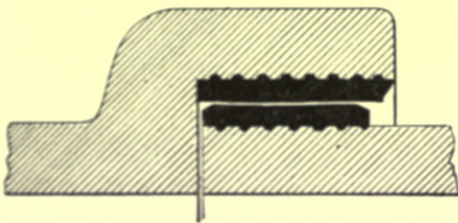

Fig. 321.—Doulton's "Self-adjusting" Drain-pipe Joint.

that on the spigot is of a convex form, and therefore admits of deflection on the same principle as a ball-and-socket joint; the lining on the socket is cylindrical,—that is, of the same diameter throughout its depth, and partial withdrawal of the spigot therefore does not impair the joint. It is free from complication and efficient, as very little depends upon the workman, the work to be done in the trench being reduced to a minimum. The pipes are supplied with the joint attached, and the spigot of one has only to be inserted into the socket of another to make the joint complete.

cal,—that is, of the same diameter throughout its depth, and partial withdrawal of the spigot therefore does not impair the joint. It is free from complication and efficient, as very little depends upon the workman, the work to be done in the trench being reduced to a minimum. The pipes are supplied with the joint attached, and the spigot of one has only to be inserted into the socket of another to make the joint complete.

The single-lined pipes of **Hassall's patent joint** are shown in fig. 322. It is somewhat similar to Stanford's, but the sockets are much deeper. In making this joint, the ring and collar are first coated with a specially-prepared plastic

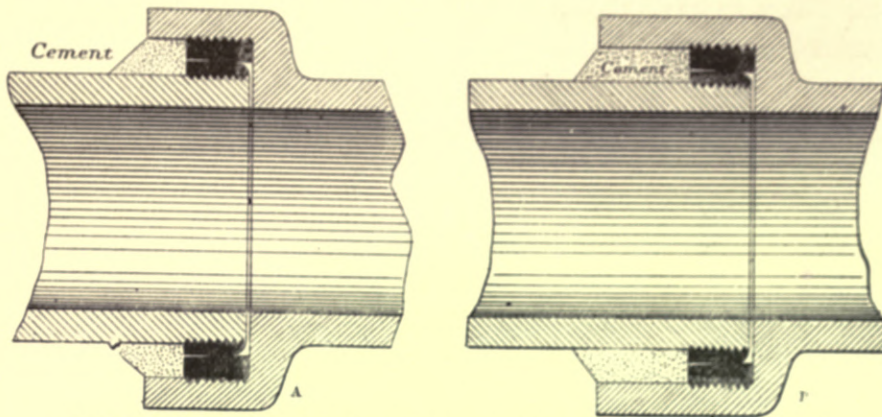

Fig. 322.—Hassall's Single-lined Drain-pipe Joint A, with ordinary socket; B, with deep socket.

cement (which is sent out with the pipe), and then the pipes are pushed home; only the joint is set flush, plastic cement filling up the interstices between the spigot and the abutting edge of the socket; the joint is then completed by pointing with Portland-cement mortar.

There are obviously many **advantages in using special forms of pipe-joint**. There is a certainty of always getting a perfectly sound, straight, well-glazed, and truly cylindrical pipe, as none but the best pipes are selected for the purpose of jointing in a special form, and while the labour involved in this process of selection must necessarily be paid for, the extra cost is certainly recouped by the excellence of the pipes. There is also the facility in making the joints, and the rapidity with which they can be completed as compared with caulked joints.

Where running sand or subsoil-water is likely to be met with in the ground, or where the drain is laid close to a water-course, and where special precautions must be taken to exclude a possible percolation of water through the joint, and provided there is nothing otherwise to interfere with a rigid joint being used, it will be found an advantage to adopt one of the other forms of joints, such as the spigot-and-socket joint with provision for pouring in liquid cement.

Hassall's patent safety joint (double-lined) can be used with advantage, as it can be readily and rapidly made in water; wherever thoroughly reliable work is desired, this is undoubtedly the best pipe to use. I quite coincide with the opinion expressed by Mr. H. Percy Boulnois, M.I.C.E., late City Engineer, Liverpool, in his *Municipal and Sanitary Engineer's Handbook*, that "Hassall's pipe is the best at present known to engineers and surveyors". It will

be seen from the illustrations that there are two rings of composition in the socket with a space of about $1\frac{1}{2}$ inches between them, and that there are corresponding collars in the spigot. The mode of making the joint in the trench is as follows: Lay a band of plastic cement, marked A in fig. 323, a sixteenth of an inch in thickness, on the whole face of the composition lining, and lay another band, marked B, in the groove of the outer collar cast round the spigot. Then place this spigot end inside the socket of the pipe lined with plastic cement,

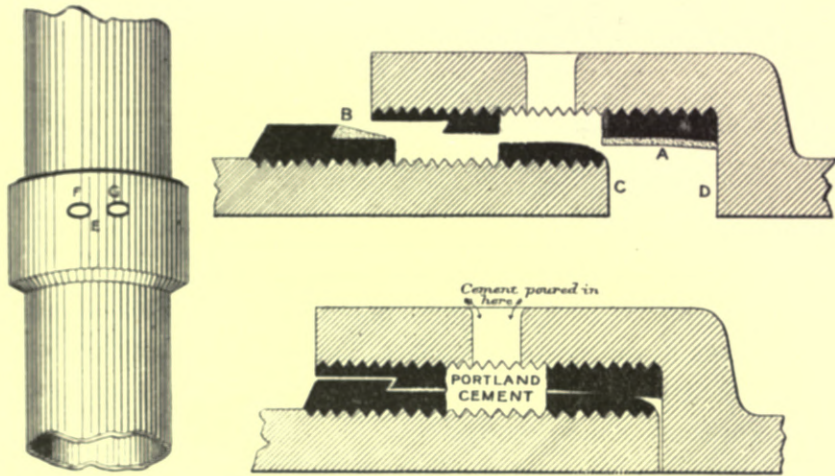

Fig. 323.—Hassall's Double-lined Drain-pipe Joint.

and press it home with an iron bar or other suitable appliance, until the end of the spigot of the one pipe, marked c, abuts against the inner shoulder within the socket of the other pipe, marked d. The two bands of plastic cement will thus be compressed as shown in the drawing of the completed joint, leaving an annular space or groove between the inside of the socket of one pipe and the outside of the spigot of the other pipe. This annular space is filled with a mixture of five-and-a-half parts of neat Portland cement and three parts of water. Before pouring this cement into the annular groove through the opening F, a piece of plastic cement must be put under the bridge E (which divides the two holes F and G), to block up the space underneath this bridge, so as to compel the Portland cement to run in one direction round the whole of the annular space until it appears again at the opening G; unless it does so appear the joint must be remade. The Portland cement should be poured through a funnel placed in the opening F, so as to run round the groove under pressure, and drive out all air or water that may be in it. The plastic cement is supplied with the pipes. The Portland cement should be perfectly free from lumps, and

well mixed (but not until it is required for use), and should be well stirred before being poured into the joint.

If pipes are jointed and the Portland cement is not poured in at once, the two openings, F and G, should be covered by a flat piece of clay, so as to keep the annular space free from grit, &c., until such time as it is filled with Portland cement.

The advantages of this joint are: (1) it is air-tight and water-tight; (2) the joints are the strongest parts of the sewer; (3) a true invert is secured by the pipes being centred properly when the bituminous bands are cast on; (4) the pipes can be laid in water; (5) in consequence of the joints being water-tight, the sizes of the pipes may be reduced; (6) the jointing material cannot be washed out; (7) the sewage can be passed through the pipes directly they are laid, without affecting the joint.

A pipe designed very much on the lines of Hassall's is **Button's patent "Secure" joint**, shown in fig. 324. On the spigots and in the sockets of the pipes, a bituminous material is cast by means of improved and patented apparatus. In these cast rings, grooves are formed in such a way that, when the spigot of the pipe is placed in the socket, an annular groove is obtained, into which cement is run to seal the joint. The cast rings have true bevelled surfaces which allow of easy fixing, and when the groove has been filled with cement, a perfect key is made, which renders the joint not only strong but absolutely water-tight.

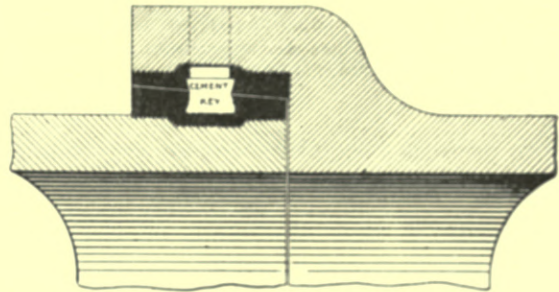

Fig. 324.—Button's "Secure" Joint.

Another well-known pipe, for which cement is used in completing the joint, is **Green's patent "Truinvert" pipe**, shown in fig. 325. The object of this patent is to form a perfectly-level bottom or invert, to strengthen the socket at its weakest point, and to make a triple joint in a cheap and effective manner. The inner socket is continued all round instead of being semicircular only, and thus forms a level invert whichever side up the pipe is fixed; at the same time it strengthens the socket all round instead of in one portion of the circle only, and it enables a triple in place of a double joint to be made. It is claimed that this pipe secures true alignment of invert, increased strength in the socket, three gas and water-tight connections at every joint, and while allowing for a slight settlement when first laid, forms an absolutely rigid joint directly the cement sets.

The drawings and descriptive references thereto show clearly how these results are obtained. It should be added, however, that the inner joint *c* is formed by

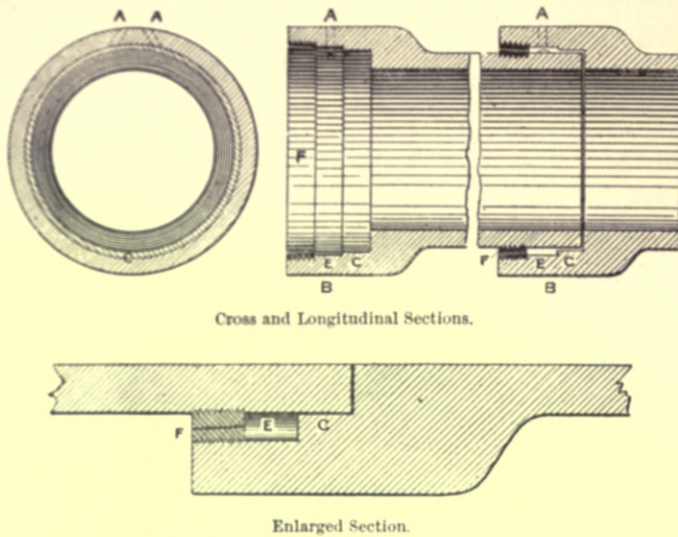

Fig. 325.—Green's "Truinvert" Drain-pipe Joint.

A A, holes for pouring in the cement or composition; B B, strengthened and lengthened socket; C C, inner socket and rest; E E, chamber for cement or composition; F F, Stanford joint in new position.

into grooves formed on the spigot, thus giving a perfect seal at the seat of the socket. Stud or rest pieces are formed midway in the socket, or thereabouts, to ensure a true alignment of the invert at the joints; this true invert is

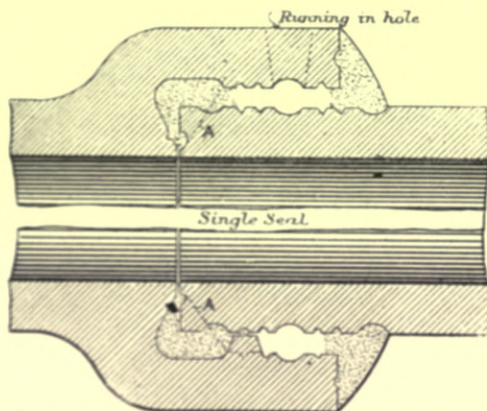

Fig. 326.—Ames and Crosta's Single-seal Drain-pipe Joint.

ensured without impairing the efficiency of the joint, the rest pieces being entirely surrounded with jointing material. A running-in hole and rising hole are formed in the socket, so that the space between the two sealing-chambers may be grouted with liquid cement. When jointing these pipes, the sealing-chamber at the seat of the socket should be filled with clay, plastic cement, or other jointing material to the dotted lines A, the spigot should then be forced home into the sealing-chamber, when the displaced jointing material will be forced into the jointing space, overlapping the end of the spigot, thus forming a perfect seal at the seat of the socket. A fillet of the same material should be worked round the entrance of the socket, and the joint may then be grouted through the

lining the socket with a small quantity of special waterproof cement, supplied free with the pipes.

Ames & Crosta's single-seal joint is shown in fig. 326. In this joint the socket is made somewhat deeper than an ordinary one, and has a specially-formed sealing-chamber at the seat, so constructed that the jointing material, displaced from the sealing chamber by the spigot, is prevented from entering the pipes, and is forced

into the jointing space, overlapping the end of the spigot, thus forming a perfect seal at the seat of the socket. A fillet of the same material should be worked round the entrance of the socket, and the joint may then be grouted through the

running-hole with liquid cement. If desired, liquid cement may be dispensed with, and the joint made up in the ordinary way with stiff cement or clay.

The **double-seal joint** for water-logged ground (fig. 327) has the sealing-chamber at the seat of the socket and rest pieces to ensure a true alignment of the invert, but the socket is extended, and a collar is formed on the spigot with a sealing-chamber similar to the one at the seat of the socket. In making the double-seal joint, the sealing-chambers at the seat of the socket and in the collar on the spigot should be filled with suitable stiff-jointing material, and the spigot forced home; a perfect seal will thus be formed at each end of the joint. The cavity between the seals can then be grouted with liquid cement. Care should always be taken to lay the pipes with the dart on the top, as this mark will indicate that the pipes are laid in the correct position.

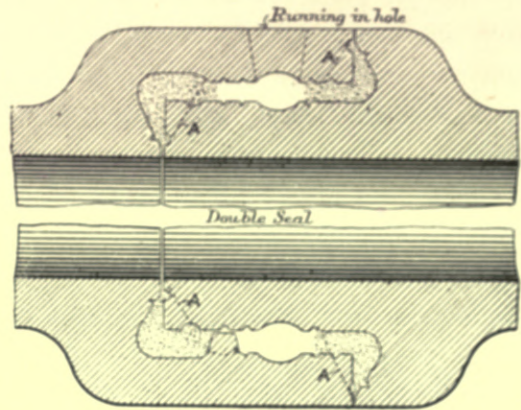

Fig. 327 — Ames & Crosta's Double-seal Drain-pipe Joint.

Within the last few months **Wakefield's drain-pipe joint** (fig. 328) has been introduced with the object of overcoming the irregularity of invert caused by

the settlement of the spigot within the socket, the improvement being effected by forming two corrugated ridges in the socket with a space between. By this contrivance the spigot end of the pipe will rest on four points in the socket, all the remaining space being occupied with Portland cement. The method of making this joint is as follows:—On the shoulder of the socket place a

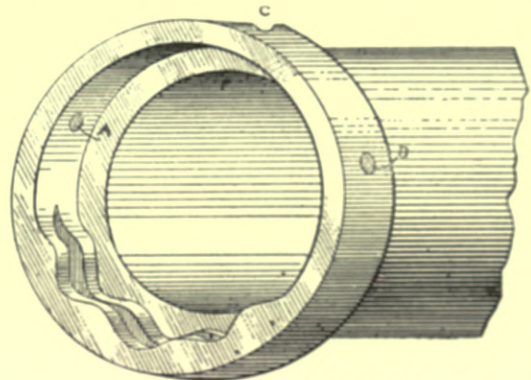

Fig. 328 — Wakefield's Drain-pipe Joint.

a band of mastic clay, then insert the spigot of the next pipe, taking care that the corrugations are always at the bottom, so as to be in position to receive the next pipe, and put a band of clay round the mouth of the socket. Pour neat Portland cement grout through the hole A till it appears at the hole B, then leave it for a few minutes; in the interval, other joints can be dealt with in the same way, by which time the cement first run will be sufficiently set to receive

the remainder without fear of bursting out the clay backing. Pour gently through the hole *c* till the crown portion of the joint is completed. It is scarcely necessary to add that in the event of any of the clay being squeezed into the pipe it must be carefully raked out. As an alternative method of making the joint, advantage may be taken of the corrugations only, for truly inverting the spigot in the socket, and the joint may be made with stiff Portland cement in the usual manner. The principle of this joint is practically the same as that of the "Rest" pipe, made about twenty years ago, but not now in the market.

There are also a great many other special joints, such as the Archer, the Paragon, Double Seal, and others.

Sykes's screw joint has recently been introduced, and is of quite another

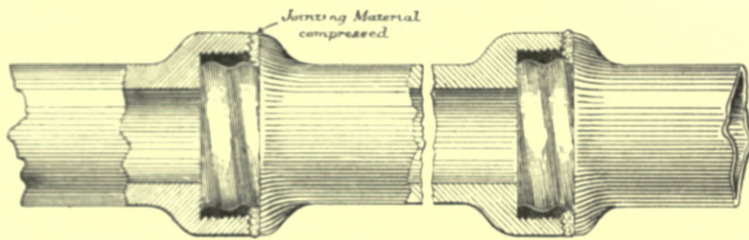

Fig. 329.—Sykes's Patent Drain pipe Joint.

form than those previously noticed, inasmuch as the composition is cast on the pipes with a male and female thread to form a screw-joint, and in making the

joint a cement composition is used, which is forced into all the interstices by the pressure exerted in screwing up. Fig. 329 sufficiently explains the principles and method of making this joint.

To make absolutely certain that no damage shall occur from a pipe-joint leaking after a lapse of years, which is often brought about by the pressure of the earth causing the drain to give way at the joint, it has been sought to increase their strength by **encasing the drains in concrete**. The Model By-laws which were introduced by the Local Government Board in 1877, prescribed that all drains should be so constructed, and this method has been insisted upon in all subsequent by-laws, regardless of the fact that what may have been the most effective method twenty years ago is not necessarily so to-day.¹ Surrounding the pipe with concrete is both a clumsy and expensive expedient, as will easily be seen, especially where the drain has to pass under a building; and one great objection to it is the difficulty of access when it becomes necessary to make a connection to the drain required by any extension of the system. This method of embedding a pipe in a surround of 6 inches of concrete would increase

¹ At the time the Model By-laws were issued, the only one of the special-jointed pipes here described in existence was Stanford's, and with the exception of Hassall's and Doulton's none of the others were known even five years ago.

the cost of a 6-inch drain under the most favourable circumstances by at least 5s. per lineal yard.

Fortunately by the use of cast-iron we are enabled not only to obtain the desired strength, but also all the advantages that could be obtained from an ideally-constructed earthenware-pipe drain.

CHAPTER IV.

VENTILATION, DISCONNECTION, AND INSPECTION.

It has already been laid down that the air-communication between **the public sewer and the house-drain** shall be severed, and that the latter must not terminate in a dead end, but be amply ventilated by openings, so as to create an undiminished current of air through the drain. The necessity for this is now admitted by all sanitarians; it is sometimes urged that, if the drain be soundly constructed upon the principles laid down herein, the time taken up in the passage of the sewage through the drain will be so short that decomposition cannot set in, but this is an erroneous notion, as, under the most favourable conditions, it is impossible altogether to avoid putrefaction. It must be remembered that the bulk of the house-sewage is discharged in eight hours, and that, for the remaining sixteen, it is often not more than a mere dribble, quite insufficient to keep the drain clean during that period, and it is then that sewage gases are largely generated.

Although here and there may be found an advocate for the maintenance of a free **communication between the house-drain and the public sewer**, there is a vast preponderance of opinion in favour of disconnection. It is quite sufficient for each house to have to deal with the smells created by that house itself; and it is in the power of householders to control the working of their own drains efficiently, but they are unable to control faulty construction and deposits in public sewers. Town-sewage is a much more complex mixture than ordinary sewage, rapidly changing in its constituents and temperature, thus constantly transforming the gases generated. Owing to these varying conditions, the construction and age of the sewers, and other circumstances, the generation of sewer-gases cannot be entirely avoided, and it is no part of a householder's duty to ventilate the town-sewer by means of the house-drain, but, on the other hand, it is his duty to see that his house is protected against the influence of

infectious matter received into the common sewers, and this can only be done by severing the sewer-air from the house-drain.

There are people who allege that there is practically no motion of air in **house-drains** except what arises from the disturbance caused by splashing at the junction, and that all effort at ventilation is so much waste energy. Attention may be called to the experiments made in this direction by Mr. Richard Horton in January and February, 1897, extending over fifteen days, and which were recorded by him in a paper read before the Institute of Sanitary Engineers on the 4th March. The experiments were made to ascertain and compare the differences of external and internal temperature of a series of drains, and to daily measure the external wind-currents at the same time as the rate of air-currents through the drain; the relative humidity was likewise taken, as well as the height of the barometer, and the state of the weather. The first drain was a stoneware pipe 34 feet long, with a lead soil-pipe and galvanized-iron ventilating-pipe 30 feet high (rising clear of the roof); the gradient of the drain was 1 in 10, and the depth of flow of the sewage varied from $1\frac{1}{2}$ inches to *nil*. A second series of experiments was made on an iron drain 5 inches in diameter and 46 feet long, having a fall of 1 in 46, the soil-pipe connected thereto being 4-inch iron rain-water pipes with lead branches for the water-closets, lead anti-siphonage-pipes and vent-pipes 60 feet high; the depth of flow varied from $1\frac{3}{8}$ inches to *nil*. A third experiment was made on a stoneware-pipe drain, 87 feet long, having a fall of 1 in 40, the soil-pipe being of lead and the ventilator 90 feet high; the depth of flow varied from $1\frac{1}{4}$ inches to $\frac{1}{8}$ inch. As a result of these experiments Mr. Horton is of opinion that our preconceived ideas as to the influences of wind-pressure must be modified considerably. Other things being equal, efficiency of drain-ventilation varies directly as the relative humidity of the atmosphere. As the air becomes drier, the velocity of the air-current in the drain increases, and as the air becomes more nearly saturated with water-vapour, the current diminishes. Where the air-current in the drain does not vary exactly with the relative humidity, the difference can be accounted for by the influence of the wind being at a greater pressure and from a drier quarter. Mr. Horton ventures to place the different influences upon drain-ventilation in the following order of value:—(1) The relative humidity of the atmosphere, (2) Materials of which the drain is composed, (3) The wind-pressure, (4) The difference between internal and external temperature, (5) Friction.

By-law 63 of the **Model By-laws**, issued by the Local Government Board, provides for drains being trapped from the sewer. The method usually selected as being most effective for the purpose is the water-trap, its position being as far

from the building as practicable, but within the curtilage thereof, and as near as practicable to the sewer. By-law 65 prescribes two arrangements for the purpose

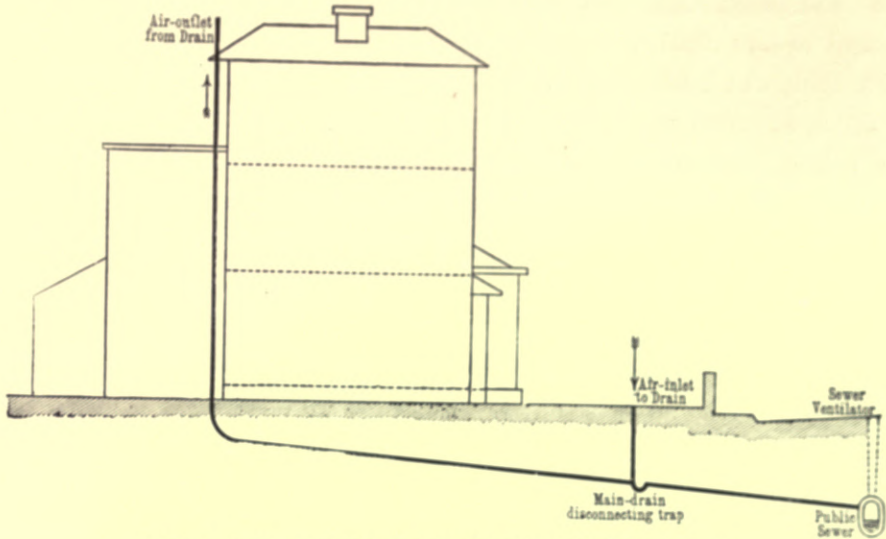

Fig. 330. —Section showing Drain-ventilation with Outlet at Head of Drain.

of securing efficient ventilation of the drains, both providing an uninterrupted passage-way from end to end, with free communication to the external air. The

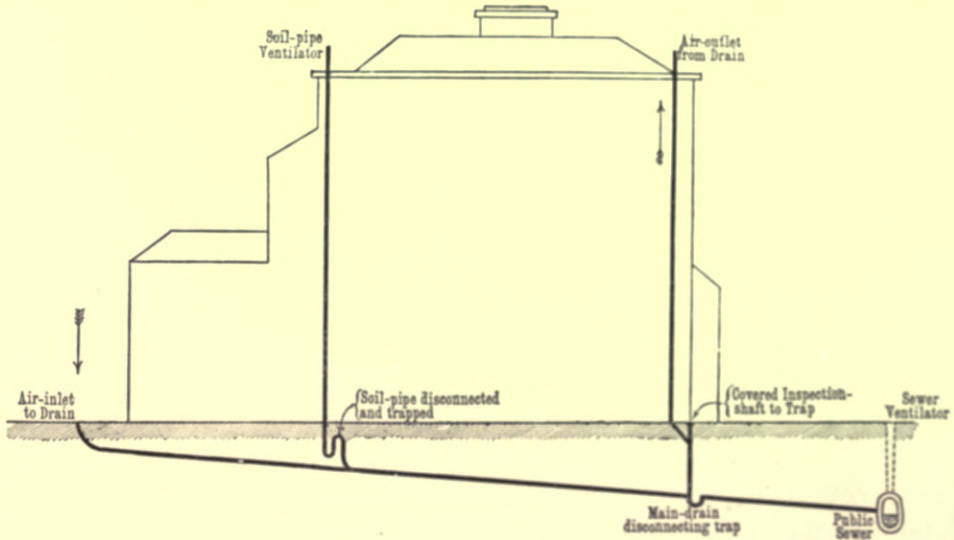

Fig. 331. —Section showing Drain-ventilation with Inlet at Head of Drain.

clause is necessarily somewhat lengthy and cumbersome, owing partly to the desirability of giving two alternative ways of carrying out the principle of the by-law. By either of these ways facilities can be provided for a constant current of fresh air through the entire length of the house-drain, and each

precludes the possibility of drain-air entering the house. The diagrams 330 and 331 show the two methods of ventilation prescribed by the by-law.

The ventilating pipes and shafts must not be less in any case than the sectional area of the drain with which they are connected. In some instances the air-inlet upon the house side of the trap is an ordinary pipe-shaft protected by a cover. A chamber or manhole, while rather more costly, is, however, of much greater value. If a shaft is used, special attention must be called to the necessity of its being a clear-way shaft, free from bends or angles, as these intercept a large percentage of the volume of air passing through, and the grating or cover which is fitted upon the shaft must have openings between the bars equal

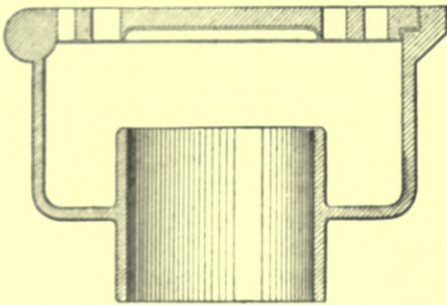

Fig. 332.—Cregeen's Air-inlet Cover.

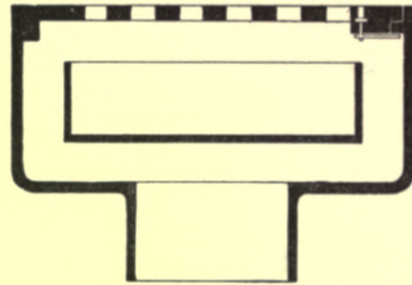

Fig. 333.—Ham Baker & Co.'s Air-inlet Cover.

in the aggregate to the sectional area of the pipe or shaft. It is also provided in the by-laws that such gratings shall be fitted with appliances for preventing the passage of dirt or other substances into the drains, and suitable covers have been designed for the purpose. One of these special covers, which has been largely used, is the well-known "Cregeen" cover, shown in fig. 332. It can be readily and securely fitted to the socket of the air-pipe; the dirt-box is formed around the cylinder, none of the air-openings in the cover being above the mouth of the pipe. This cover is made in two ways; the one being of cast-iron of strong section for use in situations traversed by heavy traffic, and the other having the dirt-box formed of stoneware, the iron-cover being loose; this is quite suitable for situations free from traffic. Another very suitable cover, manufactured by Ham Baker & Co., has a loose dirt-box in the form of a tray. The section of this cover is shown in fig. 333.

In Knight's annotated edition of the Model By-laws there are illustrations showing two methods of air-inlet, the one in the street-footpath and the other in the curb of this footpath. There are very strong objections to these methods. In the first place, the scruples have to be met of those people who have a horror of seeing any opening connected with a drain; and secondly, dirt-boxes in such

a position are liable to be tampered with, and sanitary authorities are very chary of permitting them to be so fixed. In special circumstances like these, it is preferable to construct the air-inlet as shown in fig. 334, the air-inlet pipe being fixed on the face of an adjacent wall, or if necessary, inserted in a chase formed in it. The air-inlet itself should be out of reach of any passers-by, (say) at least eight feet high, and may be fitted with a mica-flap valve to prevent any outrush of air.

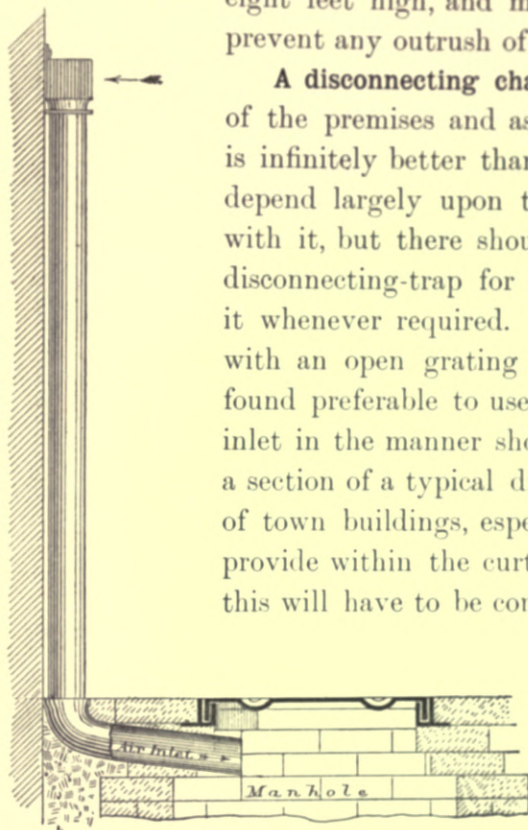

Fig. 334.—Air-inlet to Drain fixed to Wall.

A disconnecting chamber or manhole within the curtilage of the premises and as near to the public sewer as possible, is infinitely better than a simple air-inlet pipe. The size will depend largely upon the number of branch-drains connected with it, but there should be plenty of room for access to the disconnecting-trap for inspecting the drain, and for cleansing it whenever required. The entrance-cover may be provided with an open grating to serve as an air-inlet, or it may be found preferable to use an air-tight cover, constructing an air-inlet in the manner shown in the last figure. Fig. 335 shows a section of a typical disconnecting chamber. In the drainage of town buildings, especially office premises, it is difficult to provide within the curtilage a disconnecting chamber, so that this will have to be constructed under the footway, subject to

the approval of the local sanitary authority, who will no doubt not only exact a payment for the easement, but will also impose conditions as to the size, the means of access, and the projection of the air-inlet duct.

These, of course, will in a large measure be determined by the importance of the thoroughfare, the width of the footway and the amount of traffic passing over it; therefore, no hard-and-fast line can be laid down, but it may serve as a guide to illustrate and explain some constructed under my directions a few years ago in Manchester round one of the largest banks, no greater projection being allowed than 1 foot 8 inches, and the length being fixed at 3 feet 6 inches. This size will just allow a man when kneeling to get access to the trap. A bonnet-arch (see fig. 336) was turned 5 feet above the invert, and a shaft 20 inches square carried to the surface. The cover was an air-tight iron cover, but, instead of having a studded plate, ribs were cast across, and it was filled with concrete rendered

smooth, so as to be similar to the pavement. No projection of the air-pipe was allowed, so a chase was cut into the wall, and a pipe 8 inches by 6 inches inserted and secured to the wall by ears screwed into plugs. The grating was 8 feet above the footway. A number of waste-pipes of all kinds discharge into these chambers, and although to comply with the Corporation's conditions was necessarily an

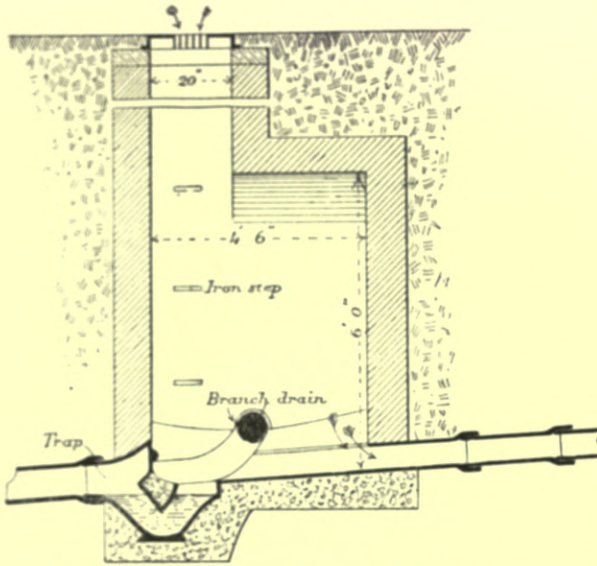

Fig. 335.—Section of Intercepting Chamber with Air-Inlet Cover.

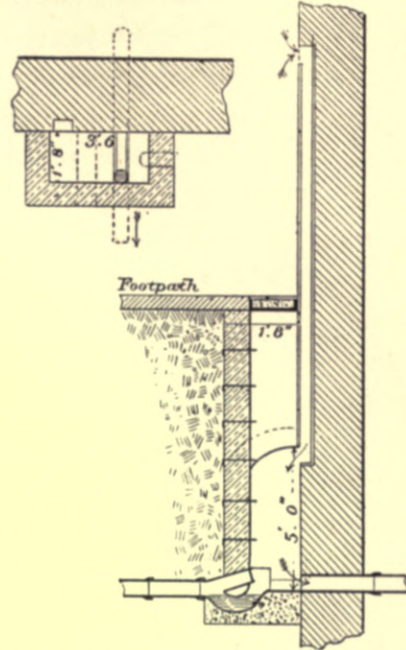

Fig. 336.—Manhole for Towns where only small space is allowed.

expensive piece of work, the chambers were satisfactory to all parties, and they have continued to work well.

Sub-section A of By-law 65 states that the second opening to the drain shall be obtained by carrying up, at the head of the drain if possible, a **ventilating pipe or shaft** in such a position as effectually to prevent any escape of foul air into the building, and of the same sectional area as the drain itself. And Sub-section 4 prescribes that no bends or angles shall be used except where unavoidable. There is a proviso in Sub-section 5 that where the situation of the soil-pipe from any water-closet admits of its being used as a ventilator, and all other things comply with the requirements previously referred to, such soil-pipe may be utilized as the sole drain-ventilator. As, however, opinions are very strongly divided as to whether the soil-pipe should be disconnected at its foot, it is proposed to discuss the question in the next chapter. It will be noticed that the ventilating shaft must be of the same sectional area as the drain itself. This requirement may by some people be regarded as inconvenient, because it

has hitherto been the custom to provide large drains, such as 9-inch pipes, even to single houses, and no doubt a 9-inch pipe-shaft at the side of a house would have an unsightly appearance. A 9-inch drain is, however, quite unnecessary for the purpose of house-drainage, and while a 6-inch pipe is commonly adopted, a 4-inch pipe is often adequate, and there is no hardship or inconvenience in providing a ventilator for either of these sizes. The importance of having a ventilating shaft of the same size as the drain seems to be very imperfectly appreciated, if one may judge from the provision for ventilation so frequently seen. It is very common to see a 2-inch pipe leading off the T-piece of the soil-pipe and carried up to the eaves of the roof, while the soil-pipe is probably connected with a 6-inch branch drain joined to a 9-inch main. It must be remembered that the areas of circles increase as the square of their diameters. The sectional area of a 2-inch pipe is 3.141 square inches, and of a 9-inch pipe 63.617, the area of the 2-inch pipe being only about $\frac{1}{20}$ of the area of the 9-inch pipe, and it would require, therefore, twenty 2-inch pipes to provide sufficient ventilation for a 9-inch pipe. Fig. 337 shows the relative proportions of 2-inch, 4-inch, 6-inch, and 9-inch pipes.

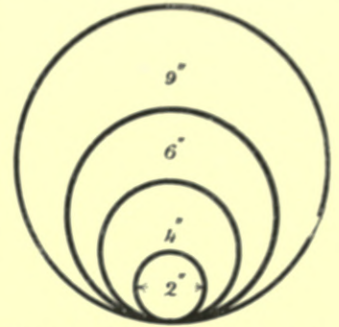

Fig. 337.—Comparative Areas of Circles.

Another common method of ventilating drains is by **connection with the rain-water pipes**. The evils of this system have already been pointed out.

Sub-section 4 of the By-law prohibits the formation of needless **bends and angles** in ventilating pipes. According to Knight's annotated edition of the Model By-laws, it has been estimated that a single right-angle in an air-pipe impedes the passage of air along it to the extent of about fifty per cent. The bends, therefore, which are so frequently seen in ventilating-pipes, defeat the object for which a ventilator is provided.

Independent ventilating pipes should be of **strong cast-iron**, securely jointed, and it is desirable to make provision for collecting the rust, which would greatly diminish the air-passage, and would very likely in course of time completely intercept it. There are numerous inventions for overcoming this difficulty, and a very simple one, designed by Mr. Fred. Lynde, A.M.I.C.E., is shown in fig. 338.

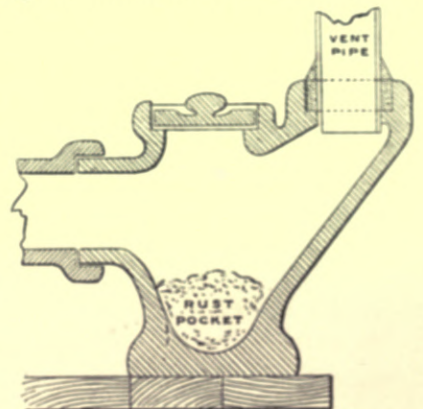

Fig. 338.—"Loco" Rust-chamber at Foot of Ventilation-pipe.

There is a great variety of opinion as to the efficacy of cowls fixed on the head of vent-pipes to induce or accelerate the currents of air. Much will depend upon the position of the terminal, which, if under the shelter of overhanging walls, will be influenced by the rebounding air and the eddies caused by such a position. It is very questionable whether even the best of these cowls is of any real value. Mr. Hellyer has made a number of most exhaustive tests,

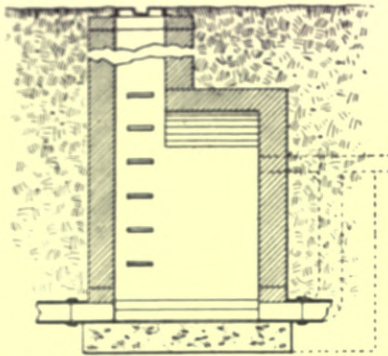
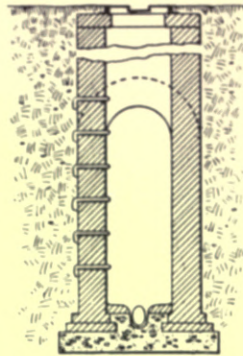

Fig. 339 — Vertical Sections of Deep Manhole.



which have led him to adopt something to prevent a down-draught, such as the mushroom cap. Where a cap is not used, the head of the ventilator should be finished with a galvanized wire balloon, which serves to prevent access by birds.

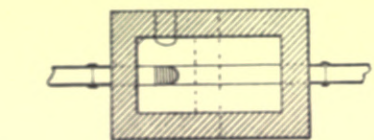
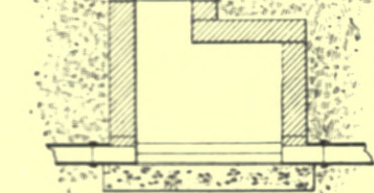

Fig. 340.—Section and Plan of Shallow Manhole.

It is not necessary to form the manholes for house-drains so large as those made on public sewers, but they should be always sufficiently large to enable a workman to turn round freely, with whatever tools he may require in clearing away accumulations, &c. Where manholes are required on drains sufficiently shallow that a man lying on the surface can get access to the drain, 3 feet \times 2 feet 3 inches will be large enough, but where drains are deeper, it is advisable not to have them less than 4 feet 6 inches \times 2 feet 3 inches, as sometimes two men may be occupied in the manhole. Manholes of rectangular shape are sufficiently strong, and are more readily constructed than circular ones. Figs. 339 and 340 show plan and sections of ordinary manholes. Of course, the shape must be altered to meet special circumstances, as at bends and junctions in drains; and where a number of branches are formed in the bottom of the manhole, the length must probably be increased. It is not necessary to carry the manhole of the full dimensions up to the surface of the ground, where the depth exceeds 8 feet. In these cases a chamber should be formed at one end of the manhole by turning an arch from side to side, or by covering it with

a strong stone "landing", and carrying a shaft at the other end of the manhole up to the surface to afford access. This shaft should be of the same dimensions as the clear opening of the entrance cover. The height of the chamber, from the invert to the soffit of the arch or under side of the landing, should be at least 6 feet, so as to allow the man working in the manhole to stand erect.

The bottoms of manholes should always be formed of concrete, properly prepared and laid to the shape of the invert, which should be accurately moulded to receive the channel. This channel should be formed of highly-glazed ware, and may be either socketed or butt-jointed. There are various ways of finishing the remainder of the bottom of the manhole; sometimes cement rendering is

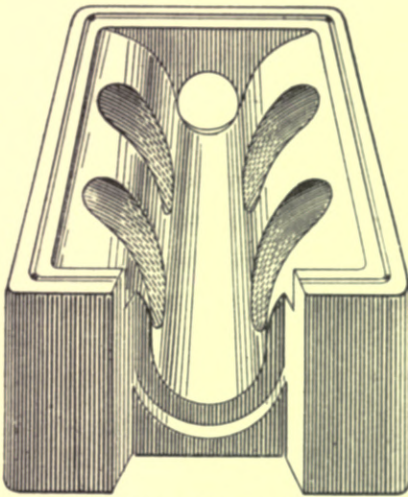

Fig. 341.—Border's Glazed Fire-clay Manhole-bottom.

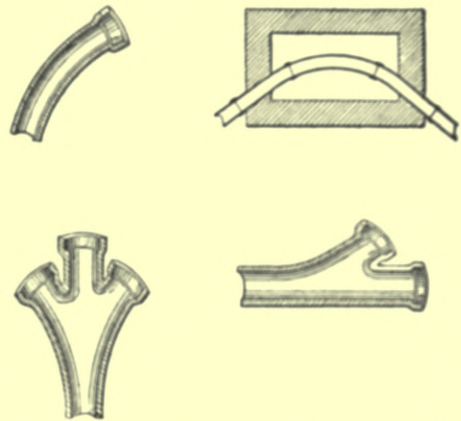

Fig. 342.—Curved Glazed Fire-clay Channels for Manholes.

used, others prefer salt-glazed or blue Staffordshire bricks, and recently manhole bottoms have been made entirely in one piece of highly-glazed fire-clay. This forms an excellent and clean bottom, and is known as Border's pattern; it is shown in fig. 341.

Drains must be laid in perfectly-straight lines from wall to wall of manhole, all **bends** being made in the manholes. Suitably-radiated channels, such as are shown in fig. 342, are made for this purpose. Branch-drains should, wherever practicable, be connected in the manhole, and should be joined to the invert-channel by properly curved pieces. These are made in a variety of forms. The channel-bends of Mr. Winsor (fig. 343) have an overhang on the outer side to prevent the escape of sewage on to the floor of the manhole, and the branches are higher than the central channel. "Wyvurst" channel-bends, with loose domed pieces, as shown in fig. 344, are also very useful.

A change of level in a drain can be most conveniently effected at the manhole. It is very objectionable to connect the drain from the higher level directly with the manhole, as the splashing leaves portions of the solids on the floor and sides, and this of course renders it impossible to utilize the manhole for

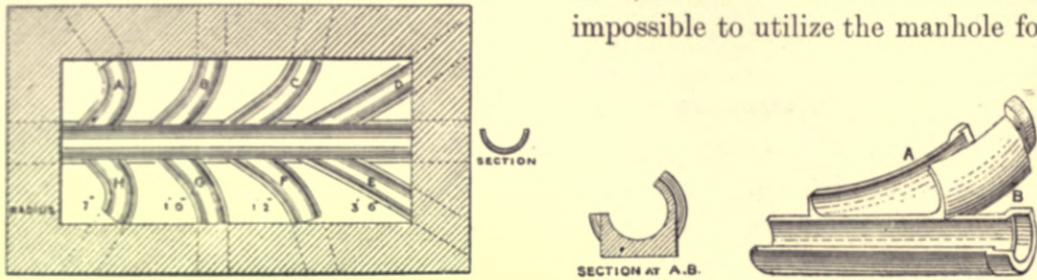

Fig. 343.—Winsor's Channel-bends.

inspection purposes. The proper way is to place on the drain, immediately behind the manhole wall, a right-angled junction with the junction downwards, and in the same wall at the invert level to place a bend, and to connect this bend and junction by means of a pipe-shaft, securely surrounded with concrete.

For inspection purposes, the pipe beyond the right-angled junction can be built into the wall of the

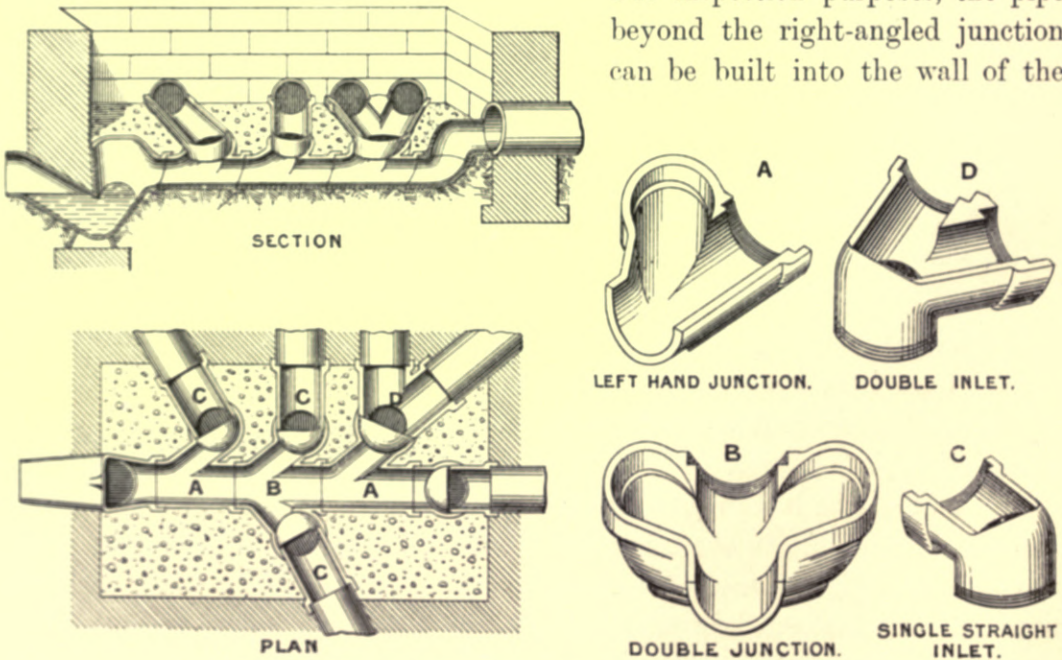

Fig. 344.—Wyvurst Channel-bends.

manhole, and fitted with a stopper, which can be removed whenever inspection is required. A very secure clip for holding the stopper in position is made by Doulton & Co., and is shown in fig. 345. This method of bringing about the

change of level in drains is shown by dotted lines in the longitudinal section of the manhole in fig. 339.

The walls of manholes should be built of brickwork, and as there is necessarily a great deal of moisture in manholes, the facing-bricks should be as hard and impervious as possible. In many districts the ordinary common brick is not suitable for use in facing; some people therefore run to the other extreme, and use best white-glazed bricks. This is an extravagance, as they possess no solid advantages over the much cheaper wire-cut brindle, or common brown salt-glazed bricks. The mortar should be made from Portland cement or hydraulic lime, and all the bricks should be bedded as closely as possible, no joint to exceed $\frac{1}{4}$ inch in thickness. All arches should be formed of purpose-made bricks of the proper radius.

For the purpose of access to the drain from the surface, **step-irons** should be built in the brick-work at suitable intervals, say, every fourth course. Steps made from cast-iron are not to be commended, as they are frequently broken by the accidental dropping of heavy objects when the cover is open. Wrought-iron steps are the most serviceable. These should be of inch round wrought-iron, formed to project about 4 inches into the manhole, and about 9 inches wide, and should be well coated with hot tar as soon as they are made.

The best stone for manhole-covers and landings is that known as York paving, which is obtained from the district of Brighouse in Yorkshire; a similar kind of stone is also obtained from the other side of the hills in the Rossendale district of Lancashire. Where the manholes are in such a situation as likely to be traversed by heavy loads, the covers should be of "landings" 6 inches thick; in other situations they should be selected from 4-inch flags. They should be holed at least 20 inches in diameter, or of other sizes to coincide with the opening of the entrance cover.

The cast-iron manhole-covers are made in an endless variety of patterns, and may be divided into two classes, one being the open ventilating cover, and the other the air-tight cover, both being cast in heavy and light patterns. If the



Fig. 345.—Doulton's Clip for Holding Stopper in End of Drain.

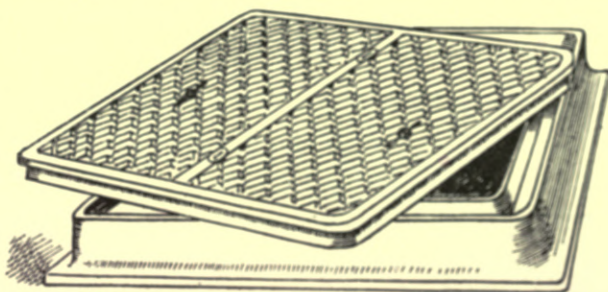

Fig. 346.—Adams's Air-tight Manhole-cover (Light Pattern).

open cover is fixed in a situation likely to be traversed by heavy traffic, such as coal-carts, &c., a strong pattern should be used, and fitted with a galvanized-

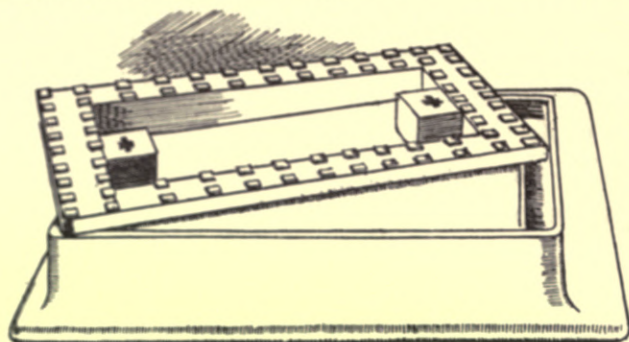

Fig. 347. — Adams's Air-tight Manhole-cover to receive Concrete Filling.¹

iron dirt-box; the light patterns can only be used in situations entirely free from traffic. The closed covers may be used where air-inlets are not required, a light-hinged cover being suitable for the purpose, except close to buildings, when the chambers should

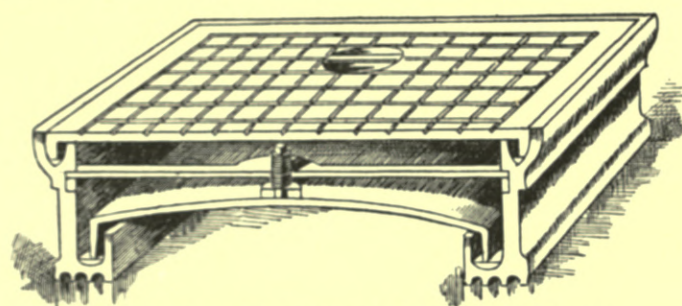

Fig. 348. — Section of Jones's Air-tight Double-seal Manhole-cover.

always be protected by what are known as "air-tight covers" (figs. 346 and 347). These are generally made by having a strip of india-rubber in the frame, into which the cover presses when closed. Instead of india-rubber, a groove in the frame is sometimes filled with sand or with oil, glycerine, or soft soap, and in addition the cover is screwed down into the frame. Where extra precautions are necessary, a "double-seal cover" may be used, as shown in fig. 348.

It is desirable to have access to all drains about every 80 yards but while

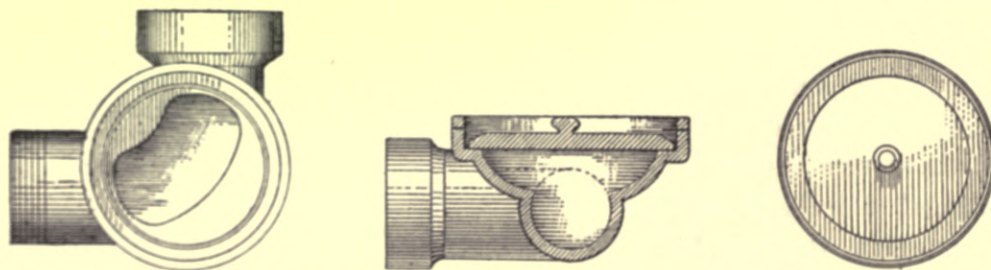

Fig. 349. — Plans and Section of "Tron" Inspection-eye for Bend.

manholes should be built at every change of direction and gradient, it is not necessary to place them upon long straight lines, except alternately with lamp-

¹ A somewhat similar cover is made to receive a stone slab.

holes. The lamp-hole is simply a plain pipe-shaft, carried up to the surface, but to make a satisfactory piece of work, this shaft should be surrounded with a collar of concrete, so as to ensure a solid bearing for the stone cover, upon which the cast-iron ventilating cover is to rest. Where the drains are shallow, great expense may be saved, if, instead of constructing manholes at the turns, the "Tron" inspection-eyes are used. Fig. 349 shows plans and section of one of these bends; the circular socketed eye-piece may be either 15 inches or 18 inches in diameter. When required to be brought to the surface, a straight length of pipe is jointed on, and the lamp-hole cover fixed in the usual way. Not only are these eye-pieces made to various curves, but they are also made with right and left oblique junctions, double-junctions, T-junctions, and Y-pieces. A four-way junction with eye-piece is shown in fig. 350. They can also be fitted with Stånford's or any other special form of joint if required.

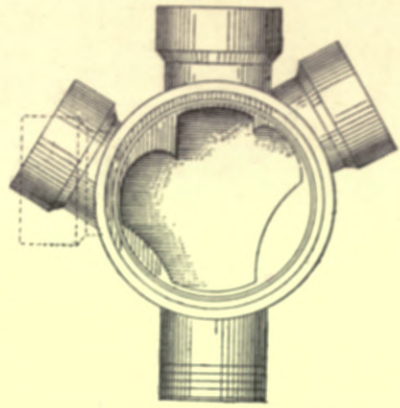

Fig. 350.—Plan of "Tron" Inspection-eye Four-way Junction.

CHAPTER V.

THE TRAPPING OF DRAIN-INLETS.

The last paragraph of By-law 62 provides that **every inlet to a drain**, not being an inlet for the ventilation of the drain, shall be properly trapped. By-law 66 specifies the particular way in which the various waste-pipes from the sanitary appliances within the building, including soil-pipes, shall be dealt with before communicating with the drain. It is our purpose in this chapter to deal with the whole of these pipes *seriatim*.

The last paragraph of By-law 62 implies that even **rain-water pipes** shall be disconnected before communicating with the drain. For many years it has been the custom in many northern towns, notably in Manchester and Leeds, to have direct communication between the rain-water pipes and the sewers. The evils and disadvantages of this system have already been pointed out, and as it is clear that the rain-water pipes should discharge into a properly trapped

apparatus, it is necessary to consider which is the most suitable for the purpose. Where a rain-water pipe discharges in a garden, or a yard not affected by traffic, an ordinary self-cleansing gully will meet all requirements. Some of these are

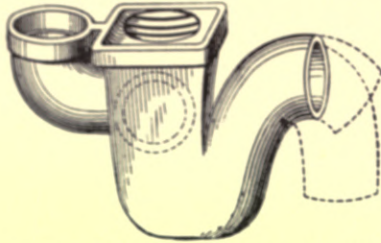

Fig. 351.—Cliff's Rain water Intercepting Gully

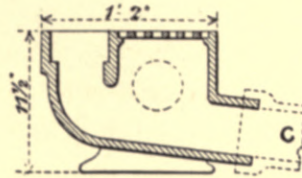

Fig. 352.—Hellyer's Rain-water "Shoe".

specially made with an inlet bend to receive the rain-water pipe, as shown in fig. 351. Fig. 352 shows Hellyer's well-known rain-water "shoe". This is made without a trap, and unless the branch-drain has an interceptor before being

connected to the main-drain, a P or S trap should be fixed at c. In the streets of towns, a stronger gully is required, and one that will take up little space, and, when set, will be flush with the surrounding pavement and free from projections. Cast-iron is the only suitable material for this type of gully. Fig. 353 shows a rain-water disconnecting gully designed by me, which will be found to meet all these requirements. The gully is divided into two compartments by a mid-feather, the rain-water pipe being connected to an union

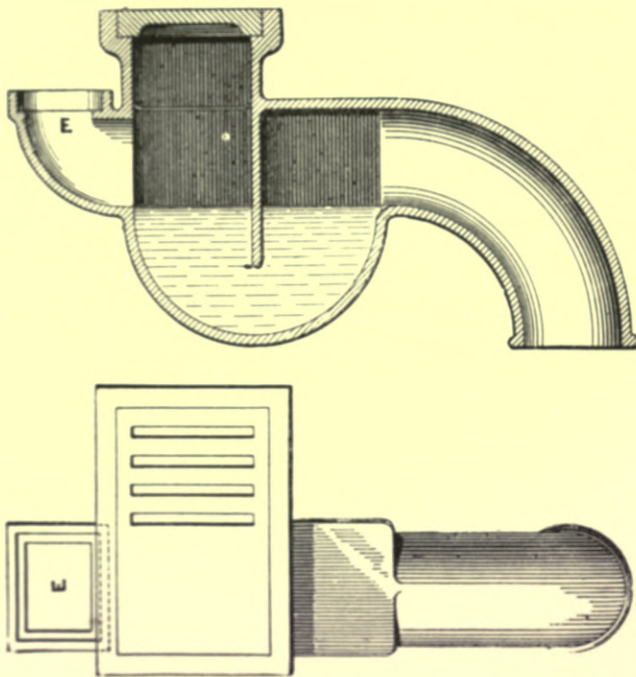

Fig. 353.—Spinks's Cast-iron Rain-water Disconnecting Gully.

E, which may be either square or round as required, and which leads to the water-compartment of the trap. One half the cover is solid, and lies over the water-compartment; the other half has ventilating openings, and any dirt which passes through is deposited in the dirt-compartment beneath. The size of this gully is only 10 inches by 6 inches, so that if the rain-water pipe is recessed

in the wall it takes up little space. should be frequently inspected to see if the seal has been lost by evaporation, and they should be replenished with fresh water as often as required.

The first paragraph of By-law 66 prohibits any **drain-inlets within buildings**, except inlets from water-closets; the object of this clause is to effectually prevent the passage of drain-air into buildings. The mere fixing of a gully-trap in a cellar floor which requires to be drained, is no effectual protection against the inroad of sewer-gas into the house. In the first place, the water-trap in the gully may lose its effectiveness through evaporation. Many of these gullies have very little depth of seal, and when the seal has vanished, the foul air from the sewer or drain passes freely into the house, as shown in fig. 354. In addition to this, it is now well established that water standing in a trap will absorb sewer-gas, and give it off inside the house. Mr. Joseph Parry, M.Inst.C.E., the water-engineer of Liverpool, in his book on "Water", page 129, gives the following results of some experiments on this subject:—

"(1) *That sewer-gases will pass through water.* Some interesting experiments on the passage of gases through traps were made a few years ago by Dr. A. Fergus of Glasgow. At the outlet-end of a trap (a bent tube), he placed a small vessel containing the test solutions, at the bottom of the S-trap, and test-papers at the top of the S-trap; the test-papers were suspended.

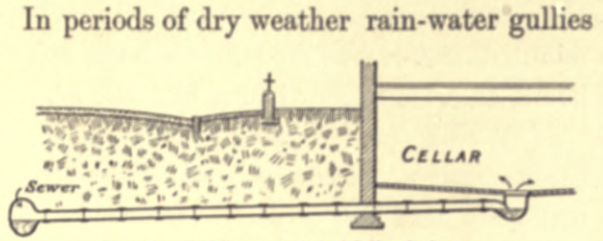

Fig. 354.—Bad Arrangement of Cellar-drainage.

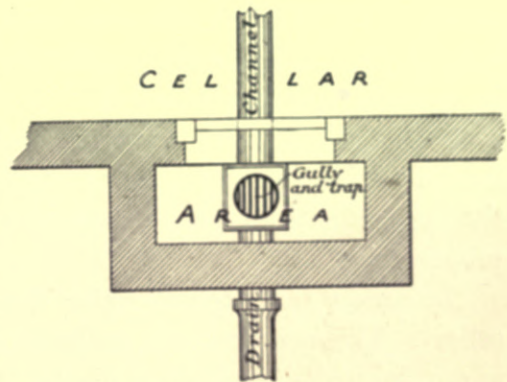
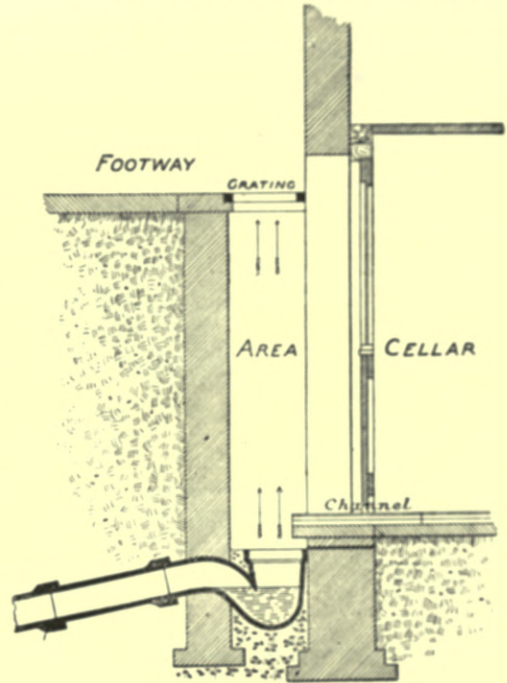

Fig. 355.—Plan and Section of Area, &c., for Cellar-drainage.

the test-papers were suspended.

He found that ammonia passed through the water in from fifteen to thirty minutes, sulphurous acid in an hour, sulphuretted hydrogen in three to four hours, chlorine in four hours, carbonic acid in three hours.

(2) *That traps may be emptied by evaporation.* If traps are placed where the water is not frequently renewed, or if a house is long unoccupied, danger may arise from this cause."

All drains should terminate outside the building, and in cases where it is necessary to carry off waste water from basements or cellars,—such as where they are used for washing purposes or as stillages for public-houses, &c.—special means must be taken to convey the waste water to the outside of the house, and the gully-trap must be placed within an area deep enough to receive this

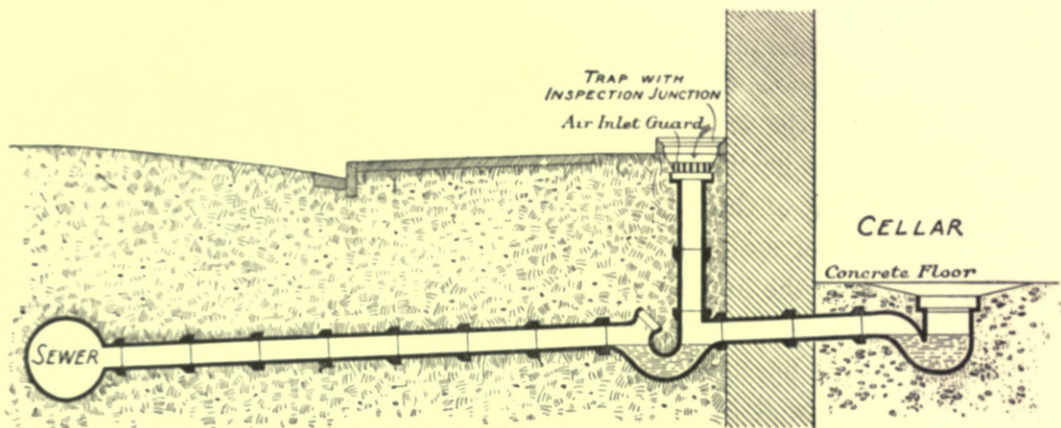

Fig. 356.—Disconnection of Cellar-drain by means of a Trap and Air-shaft.

water, as shown in fig. 355. In the case of existing cellars already drained, as shown in fig. 354, it would be expensive to disconnect them in the manner shown in fig. 355, but the same purpose may be effected by inserting an intercepting trap, and carrying up the air-inlet to the surface, as shown in fig. 356. It is particularly important that there should be no connection from the drain, even when a gully-trap is provided, to any larder or cellar in which food or milk is to be kept; the provision of a gully for carrying off water used in washing the floor is entirely unnecessary, as cellars can be effectually cleansed by the proper use of a mop.

In certain cases **subsoil-water** finds its way through the walls or floors into cellars. The insertion of a gully in the cellar floor for carrying off such water is certainly not a sanitary method. This purpose should be accomplished by a proper system of subsoil-drains outside the building.

There are many districts where, by reason of their contiguity to tidal rivers,

or through being situated in areas which are liable to sudden and rapid flooding, the basements become submerged. To meet these difficulties, special appliances must be used for keeping out the back-water which such sudden rises will cause in the main sewer. Where

the branch-drain is connected to a brick sewer, the junction-block should be fitted with a galvanized-iron flap-valve, hung to

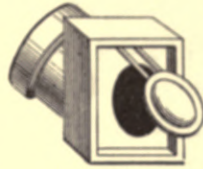

Fig. 357. — View of Swing Flap-valve, and Section of Flap.

swing freely and to close truly. To get this most accurately, a cast-iron ring should be shrunk into the block, having its outer face ground; and the face of the meeting portion of the valve should also be ground. The shape of these valves is shown in fig. 357. Another

form of valve made to secure effectual closing is the balance-valve, shown in fig. 358. This is hung inclining inwards to the branch, and is kept in that position by the counterpoised balance-weight. The small amount of water trickling down a cellar drain at ordinary

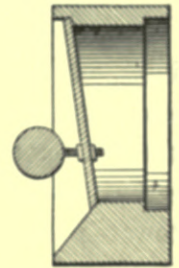
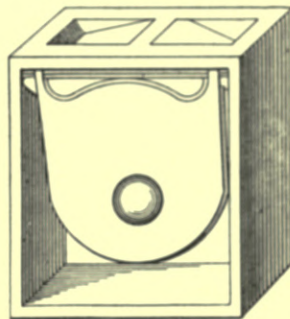

Fig. 358. — View and Section of Balance Flap-valve.

times may hardly be sufficient to keep the valve open, hence a stoppage with accumulation of deposit may take place.

In the case of areas like that shown in fig. 355, and situated in the front

of the house, nothing could be better than **Couzens's gully-trap** for preventing back-water, two forms of which are given in figs. 359 and 360. The action in each case is automatic. Any back pressure of water in the trap shown in fig. 359 raises the copper ball

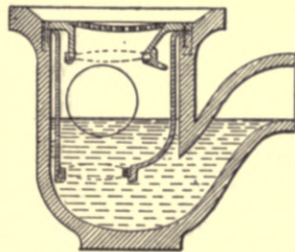

Fig. 359. — Section of Couzens's Gully-trap with Copper Ball for preventing Back-water.

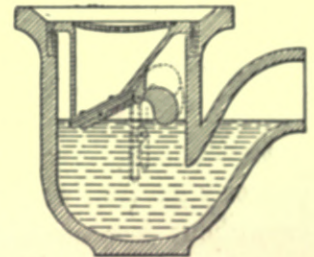

Fig. 360. — Section of Couzens's Gully-trap with weighted Door or Valve for preventing Back-water.

against an india-rubber seat-
ing, thus making an effectual seal; and should the water evaporate, as is sometimes the case in dry weather, the ball lowers on to the bottom seating, and prevents the rising of sewer-gas, provided that the ball fits perfectly. In the

trap shown in fig. 360 there is a door with a weighted lever, which allows the water to pass through into the gully, and closes automatically, thus preventing the back flow of water, and the rising of sewer-gas.

In cases where the whole of the drainage system is below flood or tide level, and therefore subject to back-water, **Dyer's valve** can be advantageously used,

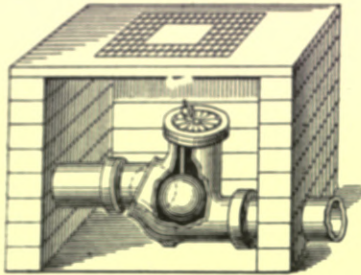

Fig. 361. — Dyer's Valve for preventing Back-water.

and may be fixed immediately below the intercepting trap. Access may be had to it by lengthening the manhole and forming a small additional chamber. The valve can be arranged for any desired fall or for a dead level. Fig. 361 shows one of these valves fixed in a chamber, one side of the valve being partly removed to show the suspended ball. The tide or flood when flowing up the drain enters the out-go branch, and floats the ball, which, as the water rises, approaches the

inlet, and finally beds itself upon the seating, thus effectually closing the orifice and preventing the water entering the building. Consequent upon this action, the greater the amount of water-pressure there is behind, the more completely sealed the trap becomes. By reason of the arm being always slightly inclined towards the inlet-branch, there is no danger of the ball sticking with the arm vertical, or of its being moved the wrong way. When the water subsides, the

ball falls with it, unsealing the inlet, and leaving a clear passage.

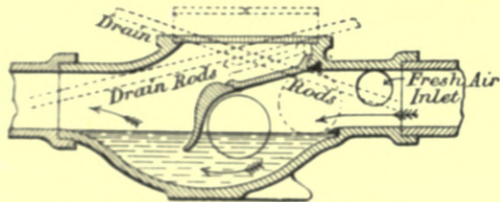

Fig. 362. — Section of Couzens's Ball-trap Interceptor for preventing Back-water.

Fig. 362 shows **Couzens's ball-trap interceptor**. The action is automatic, and any back pressure of water raises the copper ball against an india-rubber seating. The access holes are covered with iron covers bedded in suitable

materials, and secured to the fire-clay with brass screws; they are therefore perfectly gas and water tight. These interceptor-traps can be used either with or without inspection-chambers; if without, an access-shaft should be carried up from the large opening as shown by the dotted lines.

Often basements are at such a depth relatively to the depth of the sewer, that it is impossible to drain them satisfactorily by gravitation, or they may even be actually deeper than the sewer. The impossibility of providing an outlet for the drainage prevents the fullest use being made of such basements, and in business premises in towns this is a very serious drawback to their

letting value. By the adoption of a very simple arrangement, known as **Adams's Patent Sewage-Lift**, all basements may be drained, and the sewage lifted from them automatically into the public sewer. This system is shown in fig. 363, and the working of it is as follows:—The low-level sewage passes outside the building into an underground chamber (placed in a convenient position for access), where it enters a cylinder by gravitation, passing a flap-valve which prevents its return when the air-pressure is applied. This pressure is obtained from an air-cylinder placed on a higher level in any convenient position in the same or other building. An automatic flush-tank is fixed above the air-cylinder, and is fed by water from the service-main or bath-waste. The inflow may be regulated by hand or by a float on the sewage, so that none is wasted. As soon as the tank is full, its contents are discharged from the fall-pipe into the air-cylinder, displacing the air therein, which passes by a small air-pipe to the forcing-cylinder containing the sewage to be lifted, and there exerts a

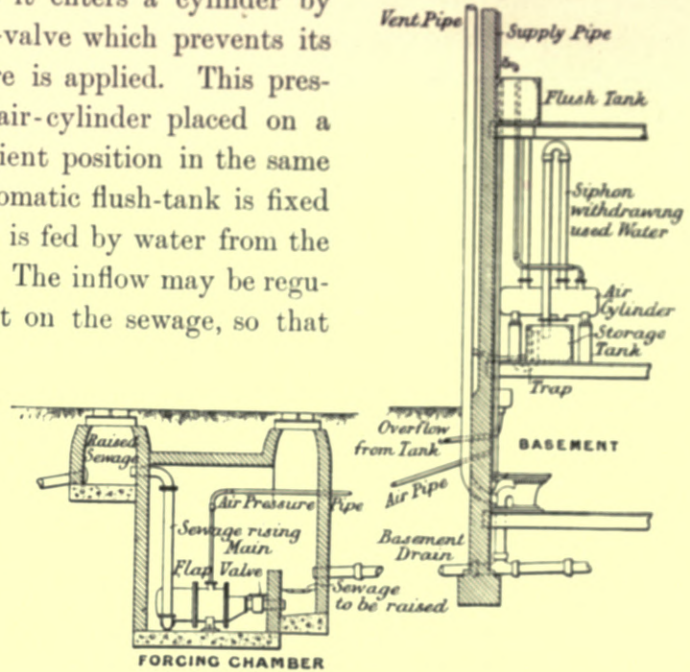

Fig. 363. — Adams's Automatic Sewage-Lift.

pressure sufficient to raise it through the rising main into the public sewer. It is necessary, in order to secure the requisite pressure, that the flush-tank should be at a height above the air-cylinder equal to or in excess of the height of maximum lift, but if it can conveniently be placed higher than this, less water is required to operate the lift, as a larger volume of air is carried down with the falling liquid, which answers the same purpose, and in this way as much or even more sewage can be raised than there is liquid falling. When the forcing-cylinder is empty the air-cylinder will be full of water, but the latter is immediately withdrawn by a syphon attached, and air again passes in, to be again expelled at the next discharge. The water thus withdrawn may be stored in a tank as shown, and again used for flushing the closets in the basement or for other purposes, or may be run off by a pipe connected to the overflow from the tank, which discharges into the chamber for raised sewage. This pipe will require to be disconnected from the chamber by an intercepting trap and air-

inlet, with a trap below the tank and a vent-pipe to the external air. If clean water only be used for flushing, it need not be wasted when discharged from the air-cylinder, but conveyed to any point where required for use.

It will thus be seen that sewage can be raised by simple automatic apparatus involving practically no expense in maintenance, in which there are no moving parts, except a flap-valve, nor other mechanism to get out of order, and which requires no manual labour or expensive motive-power. The first cost depends upon the amount of sewage to be lifted, the height of lift, and the convenience of the positions for the forcing and air cylinders and the flushing tank, and the amount of labour that will be expended in fixing them, and which will of course vary in every case. But the circumstances which affect these, while they may cause the lengthening or bending of some of the pipes, will not impair the efficient working of the arrangement, as they have no relation to the principles on which it is designed.

The third paragraph of No. 66 of the Model By-laws prohibits **traps between soil-pipes and drains**, and in the new by-laws of the London County Council the same stipulation is provided. There is great divergence of opinion amongst sanitarians as to the value or otherwise of an intercepting trap at the foot of the soil-pipe. Those who are familiar with Mr. Hellyer's work, *The Plumber and Sanitary Houses*, will remember that Mr. Hellyer is a very strong advocate indeed for the placing of an intercepting trap at the foot of soil-pipes, and his book contains a large number of illustrations showing how this plan can be adopted under a great variety of conditions. Another eminent sanitarian, Dr. Pridgin Teale of Leeds, is also a well-known advocate of this system. In the case of a small single house with only one w.c. at no great distance from the intercepting chamber, a second disconnection may not be necessary; but where the branch-drain is of considerable length, a second disconnection is a great advantage, or where there are a number of houses side by side, each connected to a common combined drain, then it is certainly desirable that there should be a second disconnection.

It is the universal practice to fix traps in the waste-pipes from sanitary appliances, and as they have to be disconnected and discharge over a trapped gully in the external air, they are therefore doubly trapped. If this is the right principle to apply to waste-pipes, it is surely right to apply it to the soil-pipe; but as it is not desirable to have the open end of a soil-pipe discharging over a gully, an intercepting trap of special construction has to be adopted with a shaft carried to the surface on the inlet side and finished with a grating. The only possible smell which can arise is when a discharge

from the closet is passing through the intercepting trap immediately after use, but as that discharge is very rapid, it is not likely that any smell will be detected. At my own house, the soil-pipe is disconnected at the foot, and the grating is within a few feet of a door, and is constantly traversed each day; I have never myself been able to detect the slightest odour, nor have I ever had any complaints whatever. Mr. Hellyer in his book also states that he has one within ten feet of his office window, and has never found it in any degree offensive; and he cites a case which shows that the system can be adopted without being in any degree objectionable. The particulars of this case are as follows:—

“About the year 1882, I had two stacks of soil-pipes fixed with a large number of valve-closets upon each, and they were made to discharge with open ends into open traps. But as the gratings over the tops of the drain ‘disconnecting’ traps were right in the footway of a narrow public thoroughfare, and as the parties chiefly concerned in the erection of the building would have been too nervous to have sanctioned any such open ventilation, nothing was said about the arrangement of such ventilating traps, and the gratings were supposed by all concerned except myself to be simply covering the ends of rain-water pipes. As a proof of the safety of such arrangement, it may be mentioned that, though the closets upon each of the two stacks of pipes just referred to have been in great use for several years, though thousands of people have walked over the gratings, and though office-windows are within eight feet or ten feet of them, no one has ever noticed the slightest disagreeable smell from the arrangement. Whenever I have examined these intercepting traps, they have been found quite free from any offensive odour, and the atmosphere has been passing freely *into* the discharging end of the soil-pipe at this point, and not *out* of it.”

There are, of course, many ways of supplying fresh air to the soil-pipe without placing the inlet immediately upon the surface of the ground or adjacent to any windows or doors.

Where the disconnection of soil-pipes is adopted, it is necessary to have an **independent ventilation-shaft** for the drains, and if the branch from the soil-pipe to the main drain is of suitable length, then a separate ventilator should be placed immediately below the intercepting trap to take the pressure of the foul air from the intercepting trap. It will be generally found that the water standing in the intercepting trap is practically clean water, being the remainder of the flush which has carried forward the soil, and that if any smell is detected escaping through the air-inlet, it will most likely arise from a stoppage in the drain, and is really a warning that something is wrong and requires attention.

Where the drain is in proper working order, there can be no reasonable objection to this system.

In a previous chapter, the principles of drain-disconnection and the reasons for it, were fully described. It is now requisite to point out the various forms of trap which may safely be adopted for the purpose. These are made in a great variety of patterns and shapes, both for use upon the drain and for insertion in a manhole. The old-fashioned **syphon-trap**, shown in fig. 364, through which the sewage flows in a continuous stream, is still largely used.

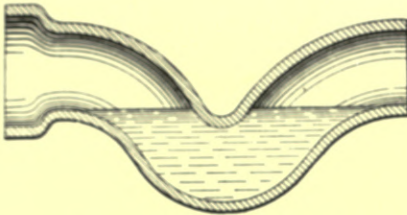

Fig. 364.—Section of Syphon-trap.

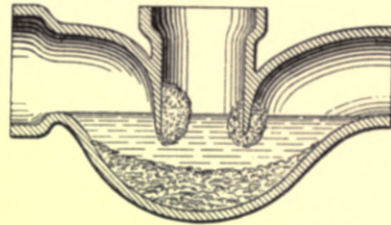

Fig. 365.—Syphon-trap with Hand-hole.

The one great objection to this form of trap is that frequently the amount of seal allowed is entirely inadequate to make proper provision against loss by evaporation; the depth of seal should never be less than $2\frac{1}{2}$ inches in any case. A modification of the plain syphon-trap, shown in fig. 365, is effected by the insertion of a hand-hole for cleaning out the trap. This is a particularly objectionable trap, as the obstruction caused by the hand-hole creates a rapid accumulation of sediment around it, which increases and hardens, and as there is not usually sufficient discharge of sewage from the house to remove it, the final result is a complete blockage of the drain.

Some people object entirely to **the use of intercepting traps**, looking upon them as a kind of miniature cesspool, and while their arguments may be good when applied to some forms of intercepting trap, it is certain that a right type of intercepting trap is of great advantage to a drainage-system. Undoubtedly in many instances the trap of the house-drain is found to be blocked with decomposing matter, but this would never have remained there, had there been systematic flushing of the drains. Most complaints as to foul odours from air-inlets adjacent to intercepting traps are made during dry seasons, when little or no rain enters the drains for flushing purposes, the only flush being from the 2-gallon cistern in connection with the w.c., which is quite inadequate, not only to carry solid matter through the drain, but even to clear the intercepting trap. With a proper system of flushing, there is no reason why intercepting traps cannot be kept constantly clean. An ideal condition of things can never be

attained in the working of a drainage-system, and a certain amount of grease, and other solid matter difficult to move, is bound to come into the drain. It is essential, therefore, that the intercepting traps should be of such a form as will offer the least resistance to the matters which have to pass through them, and their shape should be such that they will in practice be self-cleansing; further, they should not hold more water than would be contained in the ordinary flush of a single water-closet, so that their contents may be frequently changed. A trap, to be effectual, should be set level, and should have a good solid flat base, so as to enable it to be firmly and securely fixed in its proper position. Where these points are attended to, intercepting traps will be found to work satisfactorily for any number of years.

The **Buchan intercepting trap** is well known, and is shown in fig. 366. It has a straight drop of 2 inches from the inlet to the water-level in the trap, but the one objection to it is that opposite to the inlet there is a straight wall,—the design being very similar in this respect to the wash-out w.c.,—so that water coming into the trap at a high velocity comes in contact with this wall, and its flushing force is diminished, which lessens the chance of the water in the trap being completely changed.

It is important to make the fullest use of the incoming water for flushing purposes, and as far as possible to avoid its change of direction, and to concentrate it upon that part of the trap where it is most wanted. It is impossible to show every variety of intercepting trap which fulfils these conditions, but two good patterns are shown in figs. 367 and 368. An extension to the intercepting trap is shown in fig. 369, which consists of a sudden drop of 4 inches

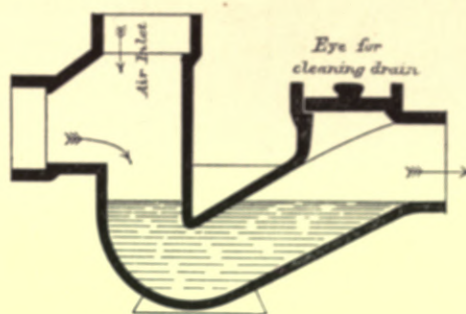

Fig. 366.—Section of the Buchan Intercepting Trap.

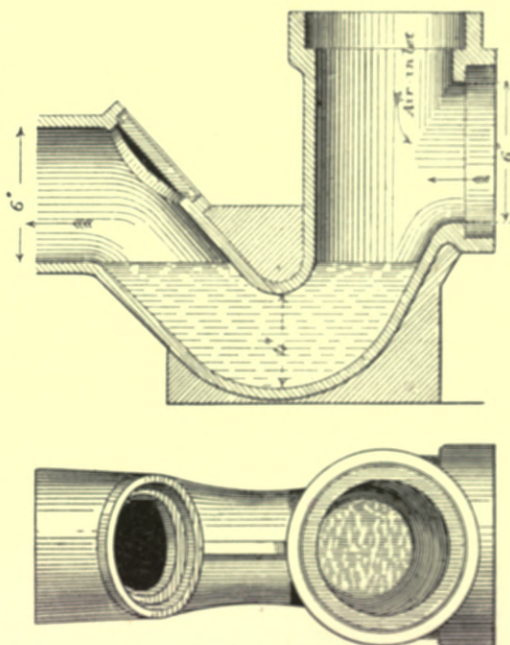

Fig. 367.—Section of the "Cerus" Intercepting Trap.

at the outlet of the trap forming a weir, which gives a cascade motion to the

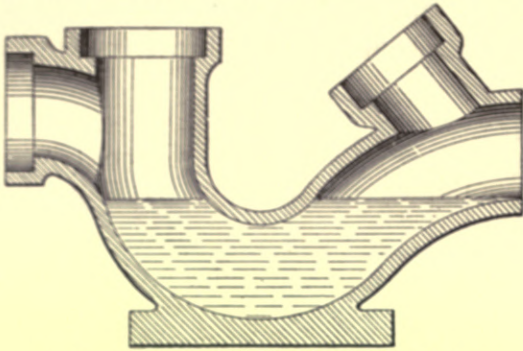

Fig. 368.—Section of Oates and Green's Intercepting Trap.

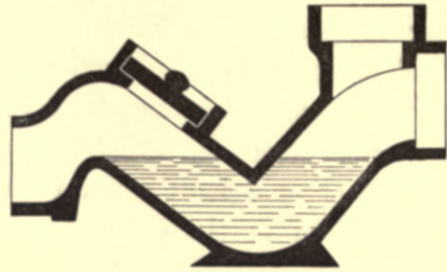

Fig. 369.—Section of Stidder's Drop Trap.

water. This is known as Stidder's Drop Trap. Another trap which may be

used without a manhole-chamber is the one known as Winsor's Patent Villa Detector, which provides means for efficiently testing the drain by simply dropping a plug into the seating below the inlet of the trap. These traps can be fixed at any depth by simply extending the shaft as required. Fig. 370 is a section of the trap and shafts connected with it. The late Mr. Slagg introduced a trap, fig. 371, which has a contracted throat, and for which he claimed that its capacity is large enough to pass the greatest quantity of water coming to it, and small enough to compel the water and sewage to pass through with twice the velocity it can possibly have when the sectional area is the same as the drain itself. The adoption of this form of trap necessitates the air-inlet shaft being constructed of brickwork, as part of the appliance consists of a short inverted shoot,

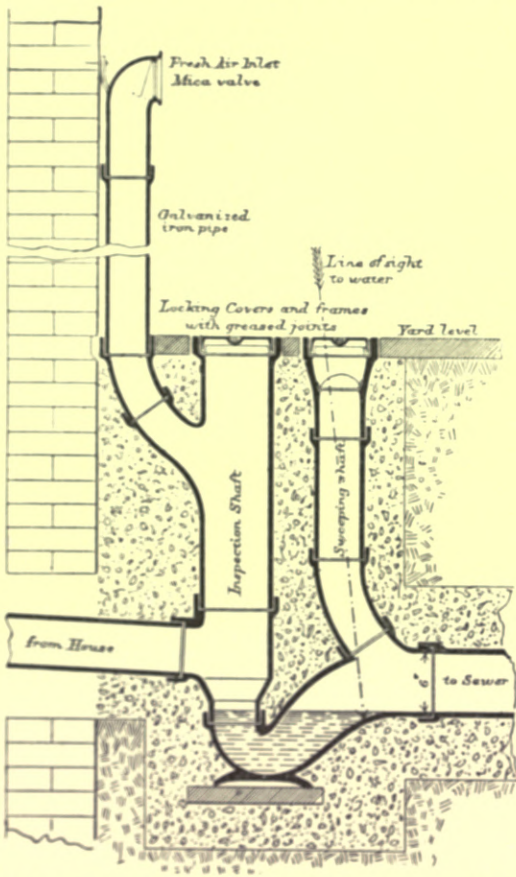

Fig. 370.—Section of Winsor's Villa Detector Trap, with Shafts for Sweeping and Air-inlet, &c.

marked A, from the drain to the trap having a fall in its length of 4 inches. There is also a slight drop at the outgo of the trap, which gives it the cascade

motion, similar to Stidder's. The "Loco" intercepting trap is shown in fig. 372. Where the drains have an equal fall, and it is desired to change the levels, instead of adopting the system for this purpose shown in fig. 339, page 448,

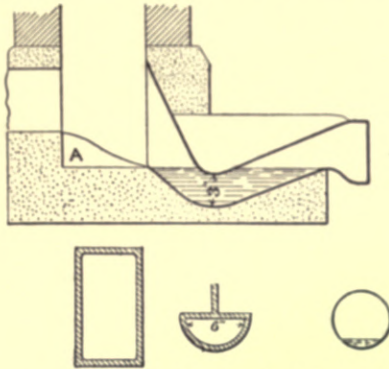

Fig. 371.—Slagg's Intercepting Trap.

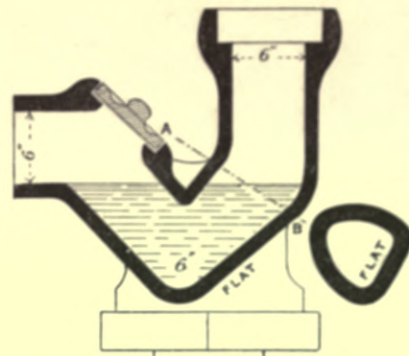

Fig. 372.—Section of "Loco" Intercepting Trap.

a modified form of this trap may be used, with a deflector bend fixed as shown in fig. 373.

Intercepting traps for fixing in manholes are designed upon the same general principles, the shape of the inlet being slightly altered to suit the brick-work and the channel in the bottom of the manhole. Instead of the hand-hole for inspection being placed vertically upwards, it is inclined and carried

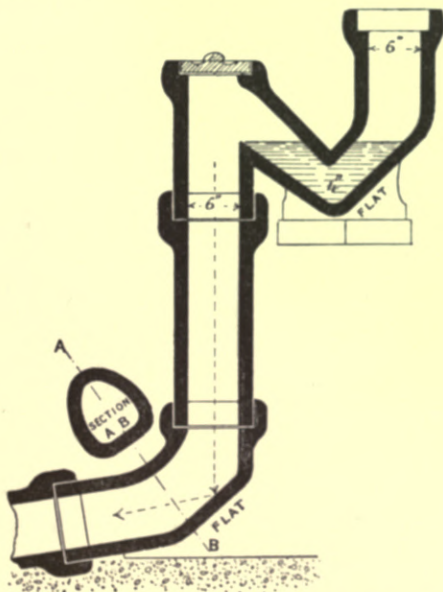

Fig. 373.—Section showing Change of Level by means of "Loco" Trap and Bend.

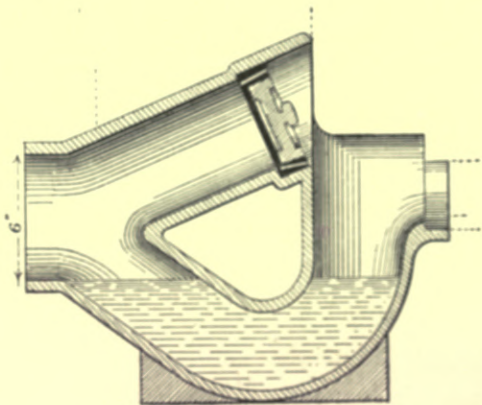

Fig. 374.—Section of "Beancliff" Intercepting Trap for Manhole.

forward so as to clear the wall of the manhole, and afford ready access to the drain. Fig. 374 shows the ordinary type of manhole-interceptor, known as the "Beancliff". Slagg's quick-motion trap, previously referred to, has also been

improved by the addition of an inspecting arm, which enables it to be built into a manhole. Another trap designed upon very similar lines is called the

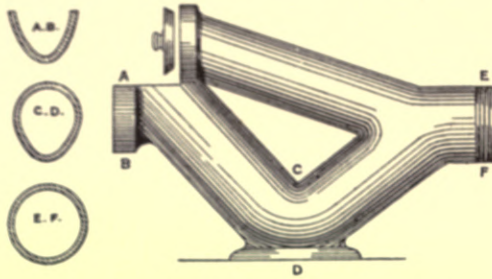

Fig. 375.—Improved "Kenon" Intercepting Trap.

"Improved Kenon Trap", fig. 375, the shape at the throat being changed from circular to ovoid with the object of getting an improved scour from the sewage during its passage through the trap. Green's Patent "Stopless" Trap possesses practically the same features.

Mr. John Jones has recently introduced a patent **stopper for the clearing-arm of intercepting traps**. Fig. 376 will give a good idea of its merits. The frame of this stopper is cemented into the socket of the cleansing-arm, and the closing or stopping plate is securely fixed in position by means of a simple lever, and when closed is absolutely air-tight. The strongest back-pressure will not

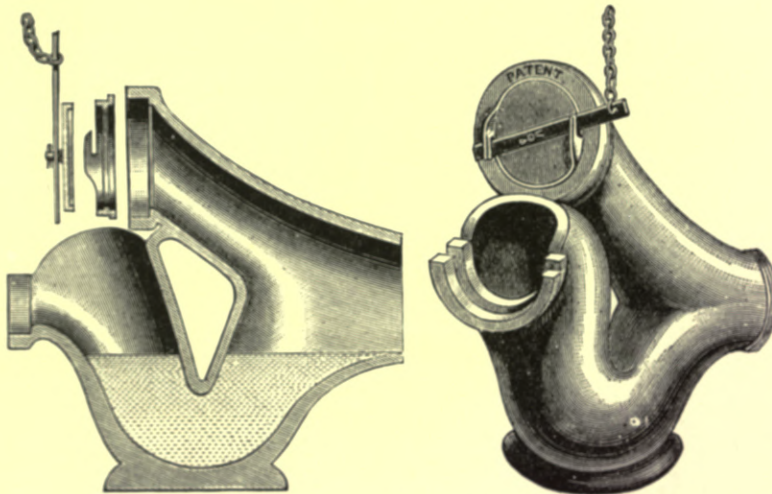

Fig. 376.—Jones's Patent Stopper for the Clearing-arms of Intercepting Traps.

blow it out. A chain is attached to the end of the lever, and carried up to the under side of the manhole-cover. Should the trap by any means get choked, and the inspection-chamber gradually fill with sewage, all that is required is to take off the manhole-cover and give a slight pull to the chain; this releases the stopping-plate, and leaves the cleansing-arm open to take away the accumulated soil. These stoppers can be made to fit the arm of any intercepting trap.

If it is preferred to have an entirely closed channel in the manhole, a **closed**

intercepting trap may be used. Fig. 377 is a section of a manhole showing the "Waverley" trap with raking eye to the sewer for purposes of inspection, and a fresh-air inlet-shaft brought up to the surface clear of the manhole. This trap has been in use for some time in Scotland, and has so far given every satisfaction. Another trap on practically similar lines, but made entirely in one piece, is shown in fig. 378, and is known as Sykes's Interceptor.

Wherever it is decided to use an intercepting trap at the foot of a soil-pipe, a slightly-modified form will have to be adopted. Brown's and Stidder's traps are very suitable for the purpose, but either of these requires a special tapering eye-piece for the air-inlet, so as to allow the air-space between the bars of the grating to be equal in sectional area to the sectional area of the soil-pipe itself. Mr. Hellyer has devised a trap which carries out this principle in a very workman-like manner. Another

very excellent soil-pipe trap is shown in fig. 379, the top part being flanged to receive an iron frame (secured by screws through the flange of the socket), in which the grating is hinged and provided with a lock, so that any authorized person can open it. This trap is made, as shown in the drawings, for outside soil-pipes, and also to receive soil-pipes from ground-floor w.c.'s. Another form of soil-pipe interceptor is shown in fig. 380, known as Green's Patent, the trap possessing the novel features shown in the cross sections, and the hopper, being loose, can be turned in any direction.

The fourth paragraph of the Model By-law 66 prescribes that all waste-pipes

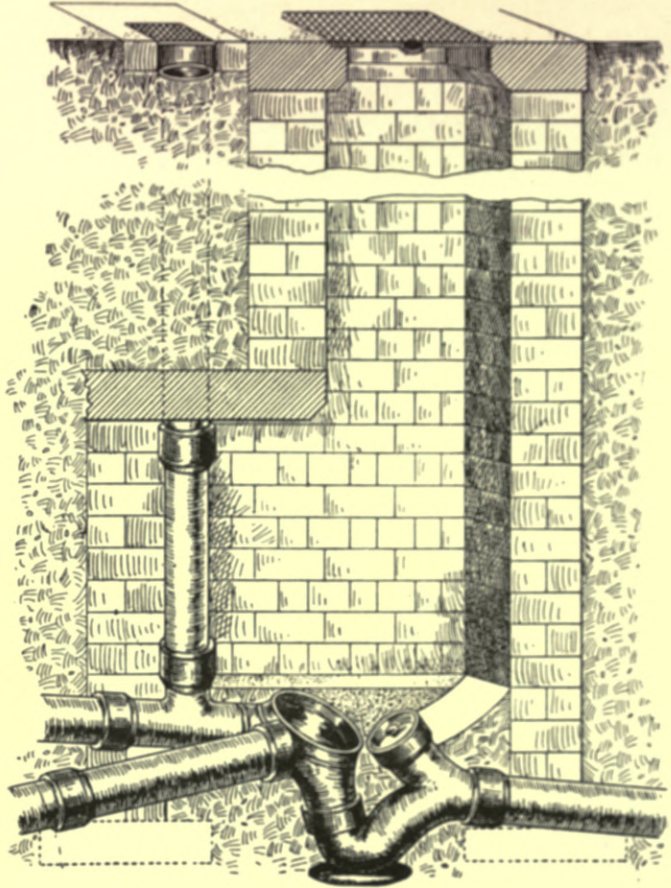

Fig. 377.—"Waverley" Closed Intercepting Trap fixed in Manhole.

from sanitary appliances within the house, with the exception of waste-pipes from the slop-sinks, must discharge in the open air over a channel leading to a

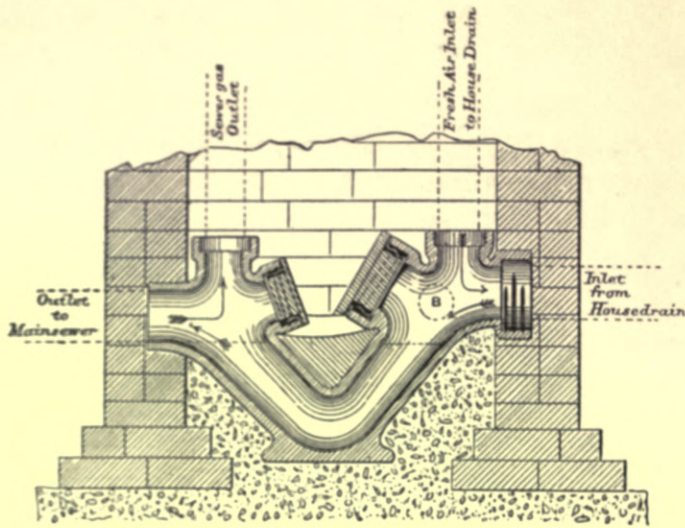

Fig. 378.—Section of Sykes's Interceptor in Manhole.

trapped gully grating at least 18 inches distant. The reason for fixing arbitrarily a definite space in the open air between the end of the waste-pipe and the gully grating is not sufficiently understood or appreciated. It has been the custom hitherto for the waste-pipe to be fixed so that the open end rests upon the gully grating, or in many cases it is inserted into the gully

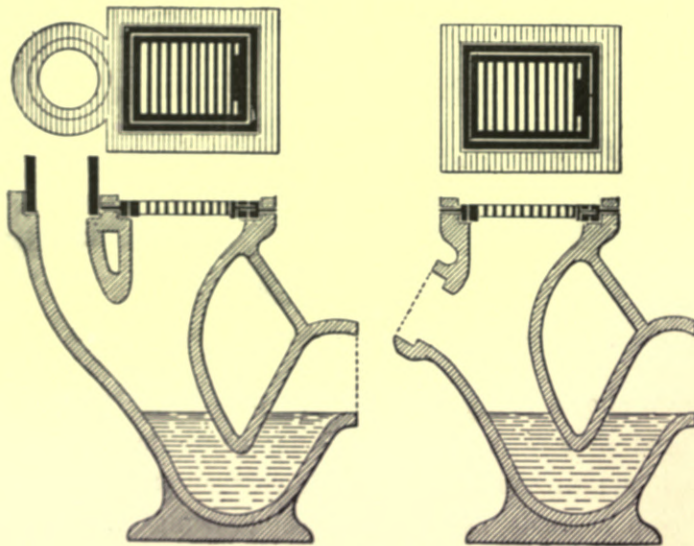

Fig. 379.—Two Forms of Trap for Foot of Soil-pipe.

below the grating. It is well known that even above the water-line there may be an accumulation of offensive matter upon the sides of the gully, the gases from which will freely pass up the waste-pipe into the house, and although there may be traps upon the waste-pipes inside the house, they are not a sure prevention against the in-road of gases. We have already seen from Dr. Fergus's experiments that gases can be absorbed by the water standing in the trap, and given off inside the house. Many gullies

which are used to receive the discharge of waste-pipes, are from their shape and dimensions liable to hold a great amount of filth, and, from the way in which they are fixed, this filth escapes and penetrates into the surrounding

ground and into the wall. Others have also a most imperfect water-seal, often not exceeding $\frac{3}{4}$ inch in depth, which is easily lost by evaporation, so that odours from any accumulation caused by defective joints in the branch drains will freely escape into the house.

The following extract from a report by Mr. Rogers Field, M.I.C.E., dated 6th January, 1876, on "Uppingham Sewerage and Private Drainage", gives a striking instance of the passage of sewer-gas through water-traps. He says: "On my examination of the sanatorium, I found that there was a bad smell in

two lavatories attached to water-closets situated one above the other. Further investigation showed that this smell did not proceed from the water-closets, but from the lavatory basins, where a decided current of very foul air was coming into the chamber from the unplugged outlet of the basins, and it was found that each basin was connected directly with a pipe which discharged into a partially-closed gully outside the house covered with



Fig. 380.—Green's Soil-pipe Interceptor.

snow, and this again into a cesspool. On opening the gully it was ascertained that the outlet was properly trapped, and that there was no apparent escape of foul gas, but that the water in the gully (though clear) had a very bad smell. In order to test whether this arose from any passage of foul gas through the trap, clean water was poured into the gully, and this removed the smell. The gully was then examined again after a few hours, and it was found that the water had assumed a very decided smell. The experiment was repeated with the same result, and it appeared that the longer the water was left after it was changed the fouler it got. Moreover, on closing the gully again after the water had become foul, the foul current of air returned in the lavatory. There could be no question, therefore, but that the smell arose from the passage of foul air from the cesspool *through the water-trap.*"

To prevent the penetration of these gases into a house, the space of 18 inches in the open air between the gully and the end of the waste-pipe should be provided. It does not necessarily follow that the gully should be placed so as to stand out 18 inches from the wall; there are many ways of providing this space in a neat and satisfactory manner.

Every gully should fulfil the following conditions:—

(1) The shape should be such as will cause it to be self-cleansing and

facilitate the passage of the liquids through it, and it must be free from angles or corners; the simpler the arrangement of the several parts the better.

(2) It should have a flat base to ensure its stability and permit of its being firmly set.

(3) It should have a seal of not less than $2\frac{1}{2}$ inches in depth—that is to say, more than $2\frac{1}{2}$ inches in depth of water must evaporate before the water-seal would be broken.

(4) The entrance should be provided with a grating, opening outwards, to allow the trap to be readily cleansed.

(5) The dish or loose cover should be designed to deliver the water rapidly into the gully, so as to prevent the escape of liquid over the sides; the cover must not be set loose upon the gully, but secured with a properly-made water-tight joint.

(6) The gully must be set perfectly level and be securely jointed to the drain.

This requirement of an open channel of 18 inches between the end of the waste-pipe and the gully has in recent years led to the bringing out of **many excellent forms of channels**, which allow of the gully being set close to the wall.

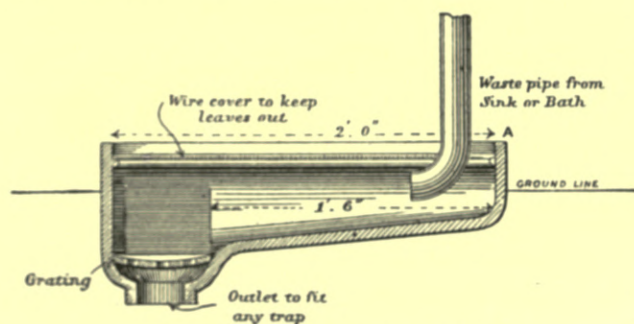

Fig. 381.—Docking's Channel for Waste-pipes.

and obtaining bends of suitable curvature. Docking's patent channel is shown in fig. 381, but in this case the channel is fitted on to a loose P or S trap, which

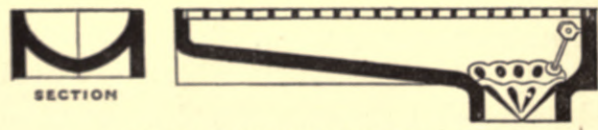

Fig. 382.—"Loco" Channel for Waste-pipes.

can of course be turned to any angle according to the direction of the drain with which it has to be connected. Fig. 382 shows the "Loco" channel. A greatly improved disconnecting slipper has been introduced by Mr. Sykes, which is shown in fig. 383. The slipper is made with a spigot outlet to connect into a loose P or S trap as required. The inlet is socketed to receive an intake piece,

One of the earliest of these was known as Stidder's, the channel and trap being all in one piece, and the channel being covered with a light iron grating to keep out leaves and litter. The trap and channel being all in one piece occasions a little difficulty in making up to old drains, owing to the cutting required

and obtaining bends of suitable curvature. Docking's patent channel is shown in fig. 381, but in this case the channel is fitted on to a loose P or S trap, which can of course be turned to any angle according to the direction of the drain with which it has to be connected. Fig. 382 shows the "Loco" channel. A greatly

which is made with one, two, or three inlet arms to receive the waste-pipes, as shown in the plan. The slipper is covered with a galvanized-iron grating, and has a very neat appearance when set.

On reference to Plate XIV., it will be seen that such a slipper might be fixed at A to receive the wastes from the bath, lavatory, and clean-water sink, but that one of the other forms of channel would be quite suitable for fixing at H for the ground-floor lavatory, and at K for the butler's-pantry sink. At E upon the plan

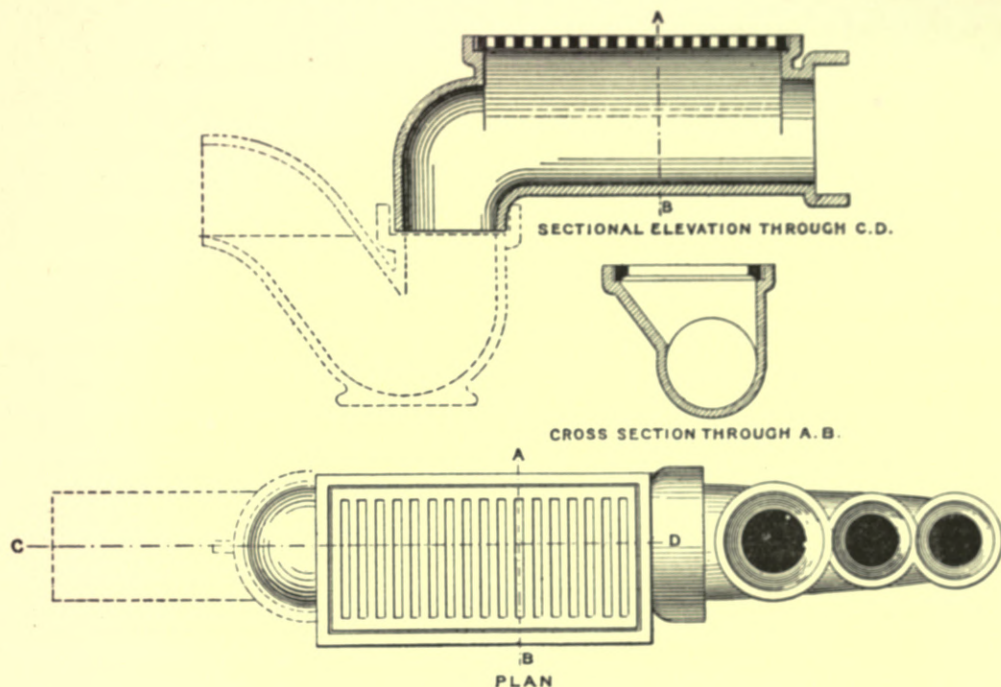

Fig. 383.—Sykes's Slipper, &c., for Waste-pipes.

is shown a gully to receive the waste water from the wash-up sink in the scullery. This gully requires to be of a special type in order to provide for the peculiarly greasy and offensive liquid produced in the washing and scraping of plates and dishes. When this liquid with its particles of food enters the drain, it congeals rapidly, and forms an obstruction from which a serious nuisance will arise unless it is speedily removed. Builders have attempted to cope with this difficulty sometimes by constructing an objectionable cesspool-gully designed to retain the solid mess, the gully being closely covered up, or else by using a very large earthenware gully, which is equally offensive.

The grease from sinks can be removed in two ways—either by adopting an appliance which collects the grease, and from which it has to be removed at frequent intervals by hand (this of course necessitates constant attention, other-

wise the system will cause nuisances greater than those sought to be remedied), or by forcing the greasy liquid through the drain before congelation can take

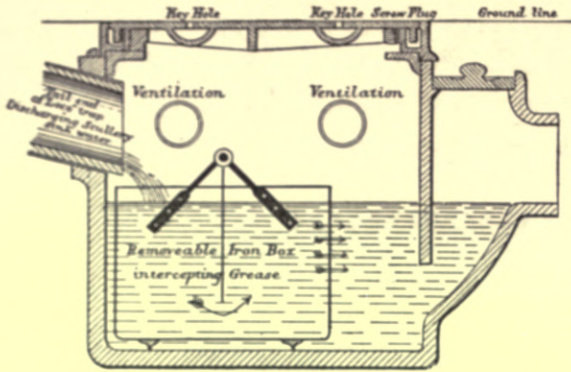

Fig. 384. — "Loco" Grease-trap with Retainer.

place. From a sanitary point of view, the latter method is infinitely to be preferred, though it has to be admitted that the adoption of either method is not strictly in accordance with the provisions of the Model By-laws, as to the space required from the end of the waste-pipe to the gully grating, but one or other of them is absolutely necessary in all houses where much cooking is

done, especially in the case of hotels, clubs, and restaurants.

Gullies for intercepting the grease are of two types, the one having con-



Fig. 385. — Grease-trap for Moderate-sized House.

tainers as shown in fig. 384, in which sand and solids are collected, the grease rising to the top, where it cakes. For moderate-sized houses a large receptacle is required, not less than 2 feet long if the horizontal pattern is adopted, of which fig.

385 is a type. Opposite the inlet a wall is carried down almost to the bottom of the box, and opposite the outlet is a similar wall, the space between these

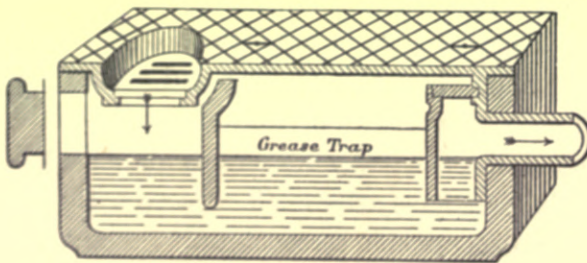

Fig. 386. — Adams's Grease-trap.

forming the grease-interceptor. In Adams's pattern (fig. 386) the movable lid is galvanized and fitted with a sunk grating. The liquid enters through this, then passes down to the bottom of the box, travels slowly across, and rises to the outlet, the silt and sand being deposited and the

grease coagulating on the top. For larger houses, hotels, clubs, restaurants, &c., a much larger collecting-box is necessary—not less than 3 feet long. The construction of these is slightly varied by the introduction of a mid-feather w, as

shown in fig. 387, which illustrates Hellyer's "extra-large" grease-trap, which has a vent-pipe *v* on the inlet-arm and an access-hole for the drain at *y* on the outlet-arm, and is covered with a holed flag in which an air-tight iron cover is inserted. Fig. 388 shows the "Eclipse" grease-trap, and needs little explanation; the greasy water from the sink, after leaving the inlet-pipe, passes to the bottom and then slowly along the entire length of the trap; the greasy particles, chilled by the large body of standing water in the trap, rise and remain in the centre chamber undisturbed by the water flowing below.

Some makers adopt a deep vertical type of grease-trap, as shown in fig. 389, which illustrates Bolding's "Simplex" grease-trap. The principle is the same as in the horizontal ones, the direction of the flow being downwards instead of horizontal.

Grease-traps are sometimes made in cast-iron instead of stoneware, and Mr. Hellyer has patterns of movable ones which are coupled to the waste-pipe by a screw-union; and there are also others which can be fitted on the floor under the sinks.

For small houses **self-cleansing grease-gullies** are much to be preferred, as there is not an excessive amount of grease requiring extra force to break it up. The gully shown in fig. 390 is known as "Le Rossignol's Patent Self-cleansing Grease-gully", and was designed specially for the purpose. It should always be fixed with the inlet *A* taking the sink-waste, and the side inlet taking the bath or lavatory waste. The angle at which the

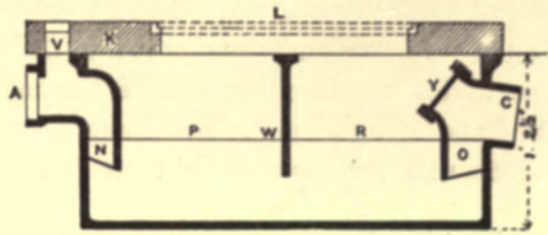

Fig. 387.—Hellyer's Stoneware Grease-gully, for Large Houses, Hotels, &c.

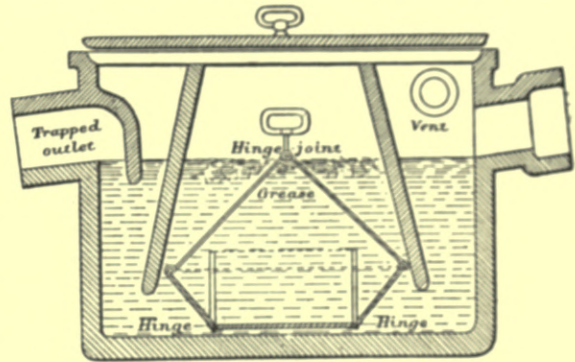

Fig. 388.—"Eclipse" Grease-trap.



Fig. 389.—Bolding's "Simplex" Grease-trap.

inlet A is constructed causes the water to rush over the lip B (where it has a fall of three inches to the level of the water in the trap) with such an impetus that it ensures the effectual cleansing of the trap, breaking up any fat floating on the top of the water, and carrying it into the drain. Additional flushing through the same inlet may be obtained from the hot-water tap, which in most houses is to be found over the sink. The trapping lip C, being at the same angle as the inlet A, offers the minimum of resistance to the scouring out of the grease. The gully

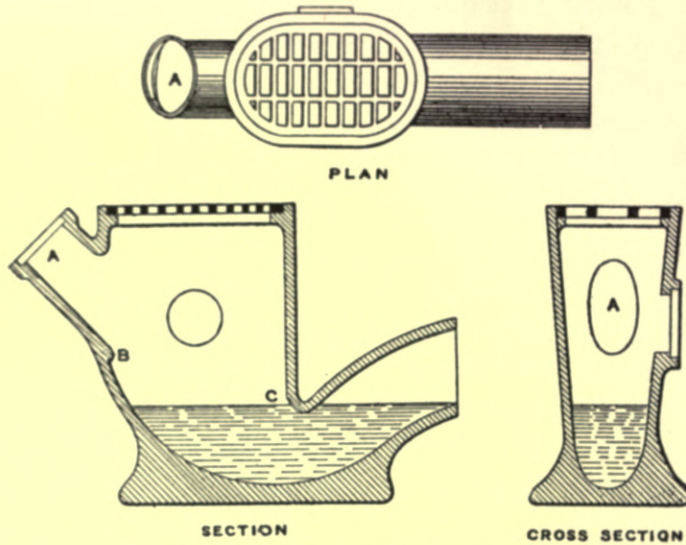

Fig. 390. — Le Rossignol's Self-cleansing Grease-gully.

should not be used as a yard gully for surface-water, and should preferably be fixed half an inch above the ground-level to prevent the entrance of gravel or grit, which might impede the scouring out of the grease.

In large establishments where there is a considerable quantity of grease, special means must be taken to despatch the grease into the drains before it coagulates. To do this successfully **special gullies with provision for flushing** have been introduced. Hot grease on entering the trap comes into contact with the cold water contained therein, solidifies, and rises to the surface; a powerful cold-water flush is introduced by means of an automatic system, and thoroughly cleanses the trap and carries the grease into the drain. Fig. 391 shows Hellyer's pattern, which is fixed in a small brick chamber. Just enough water is retained in the trap to congeal the grease; the flush from the automatic flushing tank FT enters the trap at the back, a portion of the flush passing through a flushing rim with a jet opposite the outlet for breaking up the congealed head into small pieces and floating them through the drain, the remainder of the flush being conducted downwards by a separate water-way to the bottom of the trap for

scouring out solid matter. A 20-gallon flushing tank is used, and where a head of from 4 feet to 7 feet can be obtained the flush is 3-inch bore, but where the

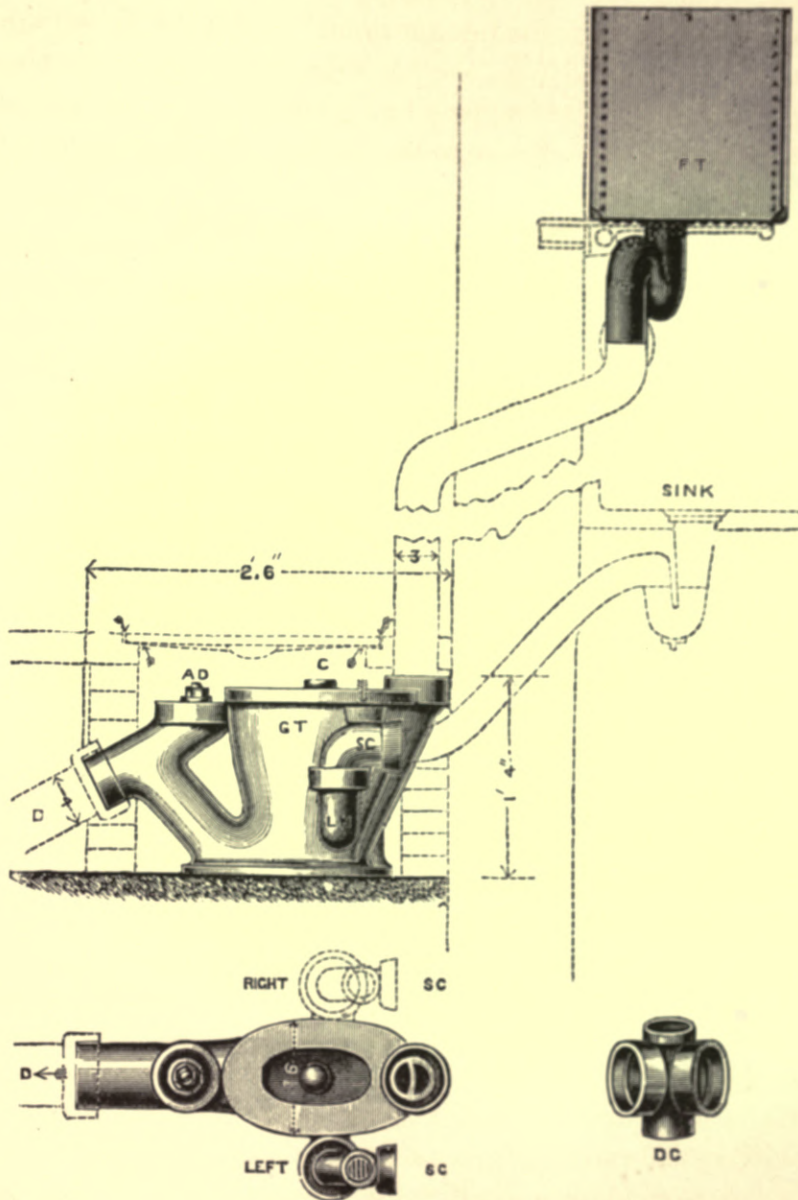

Fig. 391.—Hellyer's Flushing Grease-trap.

head is less, 4-inch. The flushing tank may be fixed in any convenient position within 20 feet or 30 feet, so long as the necessary head is obtained, and by a little contrivance the waste-water from baths may be utilized for flushing purposes, the tank being placed outside. When this position is adopted, special

means must be taken to prevent freezing, and to secure its efficient working

during the winter; it should also be covered over to keep out leaves and litter. Fig. 392 shows a very simple flushing tank manufactured by Bowes-Scott & Western. Fig. 393 shows Winsor's patent reversible flushing-rim grease-gully. It is made in two pieces. The trap can be turned in any direction to suit the drain; the upper portion can also be turned to suit the connection from the automatic flushing tank. This meets the now usually adopted plan of concentrating the wastes and rain-water pipes to a central gully, which in some cases also receives the surface-water. Fig. 394 is the same trap, but has an extra raising-piece to receive the various inlets; this allows the three pieces—viz., the connection for the drain, the connection from the tank, and

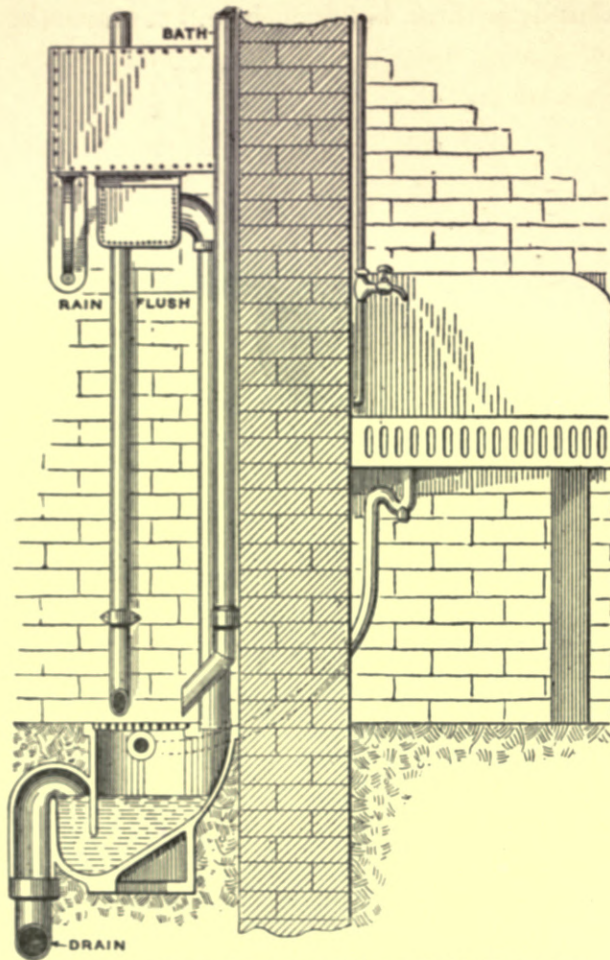

Fig. 392. —Bowes-Scott & Western's Automatic Flushing Grease-trap.

the connection for the various inlets,—to be turned in any direction independently of each other. This is perhaps a more



Fig. 393. —Winsor's Flushing-rim Grease-gully.

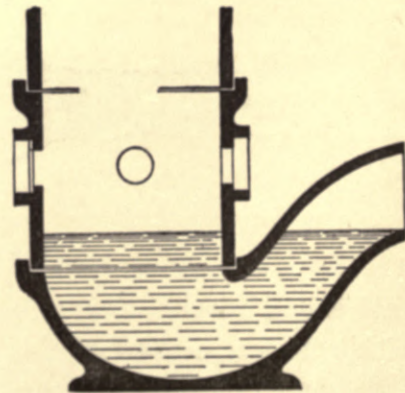

Fig. 394. —Winsor's Flushing-rim Grease-gully with Raising-piece.

convenient form, but requires an extra depth of drain. The tops are supplied with four 2-inch holes or with one 2-inch or three 4-inch holes. The outgoes of the traps are made both 4-inch and 6-inch, the 6-inch being recommended as giving more freedom to the flow of the water.

CHAPTER VI.

CONSTRUCTION OF DRAINS.

The first necessity in the construction of drains is a ground plan of the premises, showing the position of the whole of the sanitary appliances from which the waste-water has to be conveyed away, and also the position of the sewer or cesspool with which they have to be connected. In the case of a house standing in its own grounds, the plan should show the shrubberies, plantations, and paths, so that the line selected for the drains may be one that will cause as little disturbance as possible, and as far as practicable avoid the neighbourhood of the roots of trees. On the plan the drains must be marked to comply with the conditions settled in a previous chapter, taking care that manholes are fixed at all important bends, and that the branch-drains are as short as possible, and converging in manholes, so that access may be had to all of them.

It has hitherto been far too prevalent to entrust the construction of a drainage-system to odd labourers with only intermittent supervision; the result is that the pipes are huddled together anyhow in the trench without uniformity of line or gradient, imperfectly laid, and without proper foundations being secured, so that in course of time mischief inevitably ensues. Again, many houses are drained without any plan of the system having been previously prepared, the course of the drain being staked out upon the ground in what is considered the most convenient position, angles and corners being "negotiated" by sweeping curves, the idea being no doubt that they will facilitate the flow of water through the pipes, such a thing as subsequent inspection or the necessity of obtaining access to the drain being entirely disregarded. The difficulty of discovering the course of drains constructed in this manner is palpable, and the whole method cannot be too strongly condemned.

It is the custom in all works of main sewerage to prepare sections from actual levels, and upon these sections to record the levels of the various places from which sewage is to be picked up; and while it is important that this should be

done, it is equally as important that the same pains and the same care should be taken with regard to the drainage about a house, where the difficulties to be overcome in regard to levels are frequently far more intricate than in the case of main sewers. It is likewise impossible to determine, without the aid of carefully-plotted sections, the requisite fall to be given to the drain, or to select the size of pipe that will convey away the whole of the sewage and rain-water. Without the taking of levels, it is also impossible to select the most economical lines for drains — that is to say, the levels will enable us to determine the line that will involve the least amount of excavation. It may be necessary to make a slight detour, which would increase the length of the drain; but possibly by reason of the surface-levels showing that considerably less excavation in the trench would be required, economy may be thus effected without at all reducing efficiency. A section is also valuable in that it shows how it may be possible to effect changes of level in the drain; and as these will be brought about at the manholes, it may be necessary to slightly change the position of these from the places which had previously been selected upon the plan. This method of changing the levels of the drains effects considerable economy in construction without in the least deteriorating the efficiency of the drain, providing the minimum self-cleansing gradient is not departed from. The importance of this cannot be too much insisted upon. Quite recently I had to certify that a certain system of drainage which had been carried out was efficient, and I found that if this method of changing levels had been adopted, the scheme would have worked perfectly satisfactorily, and that at least £70 would have been saved in excavation alone.

The levels required are not only the surface-levels along the line of the main drain, but also the discharging levels of the outgoes from all gullies in connection with waste-pipes; and care must be taken to see whether any of these would be required either below the ground-level or in the basement. It is obvious that these levels can only be accurately taken by someone who is intimately acquainted with the operating of the usual type of surveyor's level. The levels should bear a relation to some well-defined point which is not likely to be obliterated, and which may be used for the purpose of a datum. When the situation of a house admits of it conveniently, it is preferable to commence levelling from a bench-mark of the ordnance datum, as nearly all sections of public sewers are plotted with reference to that datum, so that the laying down of the intended levels of the house-drainage upon the required section is very much simplified. The section may be plotted on any convenient scales, according to the length of line, and the variation between the highest and the lowest level recorded. Care should be used at all bends in the line and at the positions of the junctions for

branch-drains to take a level upon some fixed point which can be again referred to. The value of these levels should be clearly shown upon the section at their proper positions.

The depths of the drains shown in Plate XIV. are governed by the depth of the basement floor, and the levels at which a connection may be made to the main sewer. Where there are no cellar drains, the level at the extremity of the longest branch will govern the depth and gradient of the main drain. As there are waste-pipes in the basement both in front and at the back of the house, it will be necessary for the drain to be kept at an uniform depth from the surface; but assuming that there had been no waste-pipe at the back of the house, the proper course would have been to have changed the level of the main drain at the manhole (No. 2). In completing the section it is preferable to show the drains by red lines, and all letters and figures relating to sizes and gradients and reduced levels of inverts should be clearly marked in red; the height of the datum line above the ordnance datum or other fixed point should be recorded, and along the datum line, the distance of the various points where manholes are to be fixed or changes of direction and gradients occur, should also be clearly marked.

The next stage is **the cutting of the trench and the laying of the drain.** There are two methods of laying the pipe to the gradient required, the one being by the use of the boning-rod and sight-rails, but the more common way of working is to use an ordinary spirit-level and a straight-edge. The former is the more reliable and exact method, and is in fact the only one that should be permitted, and it is for the setting out of the required levels at the various points that the work recorded upon the section is of such value. Before describing this method in detail, some reference may be made to the other system.

It is customary to supply the pipe-layer with a **wooden straight-edge** of a given length; sometimes it is only long enough to extend over one pipe, or it may be sufficiently long to include several. It may be bevelled on one edge to the gradient required, or, as more usually occurs, the two edges may be parallel, one end having a rough-and-ready contrivance secured to it which has been presumably cut to the gauge, or very often a screw or tack is fastened at one end, projecting in the ratio of the fall required; there are also appliances specially made for "levelling" to various gradients, such as the clinometer. There are many weak points about this system which must be perfectly obvious to everyone who has had experience of it. The position of each pipe is only fixed with reference to the pipe previously laid, so that any error however slight

is carried forward from pipe to pipe, and in the case of a long drain it is quite possible on reaching the termination to find an error of several inches either higher or lower than the desired point. It is also possible for the pipe-layer—although it would be extremely careless—to reverse the straight-edge, and so error would accumulate. Again, after one pipe is laid, it may be some days before the next pipe is connected to it; in the meantime the pipe last laid may have settled, or may have got slightly misplaced, and there is no means of telling whether it is in correct position or not. So long as these things can take place, it is always well to employ contrivances that are less likely to be misused by the ordinary workman. In the case of such small works as house-drainage, it is not always possible to have constant supervision by experts; it is well, therefore, to make everything capable of being effectively done under occasional supervision.

The most efficient appliance for securing a perfectly true gradient in pipes is that known as the **boning-rod and sight-rail**. The boning-rod is an upright piece of wood cut to any convenient length to suit the depth of the drain. It is fitted with a cross-head exactly like a T-square, and at the other end a shoe is screwed on, which fits on to the invert of the pipe

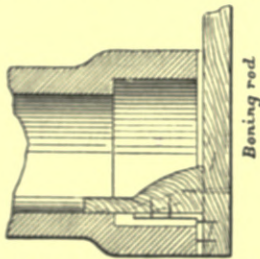

Fig. 395.—Shoe for Boning-rod.

as shown in fig. 395. This shoe should be secured to the rod by angle-iron fixed with screws, so that whenever the rod is required to be shortened, the change is readily made. The sight-rail, as shown in fig. 396, consists of a cross-bar consider-

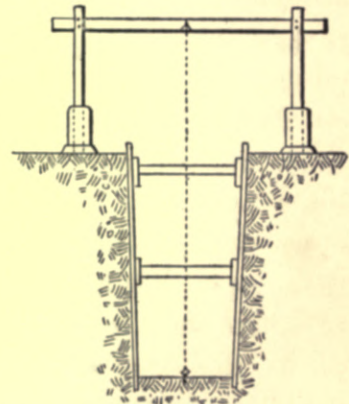

Fig. 396.—Sight-rail for Laying Drains.

ably wider than the trench, secured to uprights firmly placed in pipes well away from the edges of the trench, so as to be clear of any movement which may be caused by a sudden collapse of the sides of the trench. Two sight-rails are required, one at the point where the drain starts, and the other at the point where the direction or gradient is changed, and intermediate ones can be placed wherever convenient. Assuming the distance between manholes Nos. 1 and 3 on the plan to be 100 feet, and the gradient to be 1 in 50, that would be a rise of 2 feet; assuming the reduced level of the invert of the sewer at No. 1 to be 24 feet, and the surface-level to be 32 feet, or a difference of 8 feet, then 11 feet would be a very convenient length for a boning-rod. The sight-rail, therefore, at No. 1 would be fixed on a level of 35 feet, and that at No. 3, 37 feet. We shall now

see what assistance we can derive from having taken careful levels in the first instance. In setting up the sight-rail when the level is fixed, the operator would commence by taking a back-sight upon his nearest temporary bench-mark, and would transfer that level to the upright of the sight-rail, adding the difference required. Supposing, for instance, that at No. 1 the bench-mark read 33·73, we should require to add 1·27 to give us the value 35, which would be the height of the sight-rail; in the same way, supposing the bench-mark at No. 3 to be 34·86, we should require to add 2·14 to get the height of the sight-rail at that point, namely, 37. The levels of the sight-rails may also be fixed by placing the level midway between the two points, fixing the boning-rod in the invert of the pipe, and letting the assistant hold the staff on the cross-head of the boning-rod; the operator then takes the reading, and the assistant afterwards holds the staff on the vertical upright to which the sight-rail is to be secured at the next point, raising it or lowering it until the same level is read by the operator. Two feet must then be added for the fall which is required for the drain, and the sight-rail securely fixed level across between the

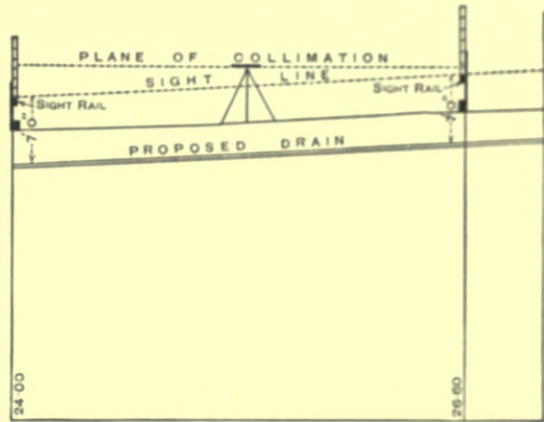

Fig. 397. — Method of Setting up Sight-rails.

uprights. A section illustrating this method of setting up sight-rails is shown in fig. 397, from which it will be seen that the sight-line is exactly parallel to the line of the proposed gradient. When the boning-rod is placed on the invert of the pipe, the cross-head should be exactly in line when looking over from one sight-rail to the other. As the work proceeds, the boning-rod is held on each pipe in succession, the pipe being adjusted until the cross-head falls exactly into line. The position of each pipe, therefore, is fixed independently of the preceding one. This method is as easy to work as any other, and it is certainly the most accurate.

Section 21 of the Public Health Act, 1875, confers the right upon the owner or occupier of premises to have his drains connected to the sewers of the Council, on condition that he complies with the Council's regulations as to the mode of making the communication between the drain and the sewer, and subject to the control of any person who may be appointed by the Council to superintend the making of the connection. The succeeding section, No. 22, permits the use of

sewers by the owner or occupier of any premises outside the district of the Council on such terms and conditions as may be agreed upon between the respective parties, or, in case of dispute, these terms may be settled by the magistrates or by arbitration. In many cases boundaries of districts are formed by the fence running along the side of a road, or the centre of a road may be taken for the boundary; so that houses outside the boundary in such cases may be connected to the sewer belonging to the District on the other side of the boundary. Section 23 of the Act confers power upon the Local Authority to enforce the drainage of undrained houses, and to cause them to be connected to any sewer, belonging to the Local Authority, which is not more than 100 feet from the site of such houses, but if no such means of drainage are available, then by emptying into a cesspool or such other place as the Local Authority directs. The Authority may require the drains to be of such materials and size, to be laid at such levels and to such falls as, on the report of its surveyor, may appear necessary. And by Section 25 it shall not be lawful in any Urban District to erect or rebuild any house, or to occupy the same, unless and until a sufficient drain has been constructed subject to the provisos mentioned in the previous sections.

In many districts that portion of the drain between the public sewer and the building-line, in highways reparable by the inhabitants at large, can only be constructed by the officials of the Councils, but where there is no rule to this effect, it is necessary for the person who is to construct the works on behalf of the owner or occupier, to obtain, as required by Section 149 of the Public Health Act, permission to break open the street, and having obtained this he is then subject to compliance with all the conditions imposed in Sections 81, 82, and 83 of the Towns Improvement Clauses Act of 1847, which are incorporated also in the Public Health Act, and which have reference to the fencing, lighting, and guarding the works and materials for the proper protection of the public.

It is also necessary to give notice of the intention **to make a junction with the public sewer**, as it is possible one may not have been left upon the sewer at the precise spot required. For the purpose of having this connection made in an efficient manner, it has to be done under the direct personal supervision of a responsible officer of the District Council, and the whole of the work from the junction to the building-line executed strictly in accordance with the Council's regulations. In those districts where the Public Health Amendment Act of 1890 has been adopted, the owner of the property may, if he so desires, under Section 18, agree with the Council upon terms to execute this work on his behalf, and so avoid the responsibilities and obligations imposed by the Council's

regulations, and the sections of the Acts of Parliament referred to above. If the Council themselves do not undertake the work, then the person undertaking the work for the proprietor must make the connection to the sewer. If no junction-pipe has been inserted in the sewer, some approved means must be taken to make the connection.

If the Surveyor to the Local Authority will sanction it, a hole may be cut in the sewer-pipe for the insertion of a **properly-curved and flanged connecting-**

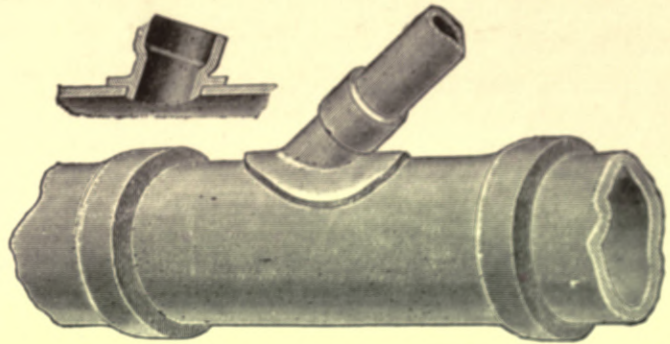

Fig. 398.—Section and Plan of Saddle-junction for Branch-drain.

collar, the spigot of which is of a depth equal to the thickness of the sewer-pipe, the flange being bedded in cement mortar upon the pipe. These collars should have sockets in which to insert the first pipe of the branch-drain, as shown in fig. 398.

To introduce an ordinary junction-pipe into an existing sewer is an operation involving considerable trouble and expense, as several pipes may have to be removed and a considerable amount of excavation thus incurred. To overcome this, Messrs. Doulton have introduced a **patent junction-pipe**, shown in fig. 399, by the adoption of which one pipe only is removed from the

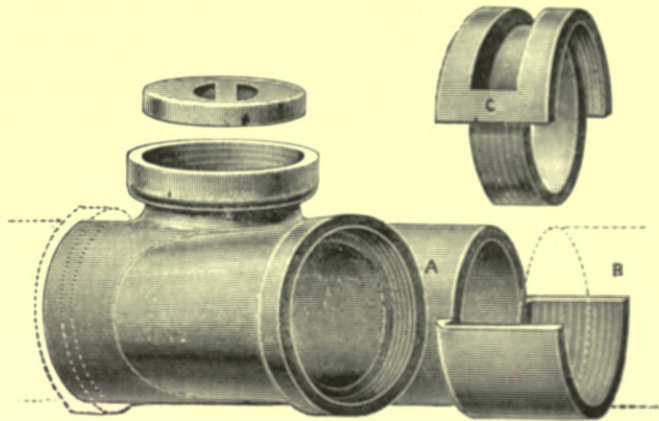

Fig. 399.—Doulton's Patent Junction-pipe.

sewer, and this can readily be replaced by that which receives the branch-drain. On removing the existing pipe, the portion A of the patent pipe is placed in position. This is provided at one end with an extended half-socket, which is entered beneath the spigot B of the existing sewer, and the spigot of the new pipe is then drawn back into the exposed socket of the sewer. The operation is completed by the insertion of the part C between A and B; this has two half-sockets at the upper side, by means of which a satisfactory joint can be made

with the pieces A and B. An access-opening is provided in the portion bearing the branch, and this permits of the several joints being finished from the inside; it can be ultimately closed by a stopper.

Messrs. Oates & Green also make a patent **socketless access-pipe**, in connection with which a loose fire-clay ring or thimble is slipped over for the purpose of making the joint. The access-hole permits the workman to put in

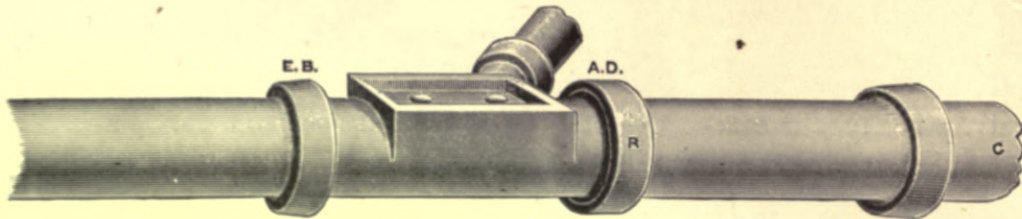

Fig. 400.—Oates & Green's Patent Socketless Access-pipe: R, loose fire-clay ring to make the socket.

his hand and make good the joints. This is shown in fig. 400, which sufficiently explains itself.

Socketed access-pipes with junctions are also made for insertion instead of the ordinary junction. In case of a stoppage in the branch-drain, by removing this access-cover an examination can be made, and if necessary cleaning tackle inserted. The diameter of the junction-piece being less than that of the main pipe from which it is branched, the invert is slightly higher, and owing to the inclination of the smaller drain, it may be necessary to set up the junction-

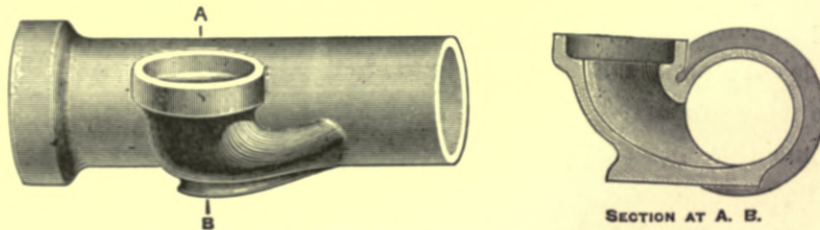

Fig. 401.—Codling's Patent Rest-Bend Junction.

piece to conform to this gradient, and in order to prevent subsequent displacement when the trench is being refilled, means should be taken to provide a firm foundation underneath the branch. In order to prevent any chance of the omission of this very necessary work, some makers have lately introduced junctions with rest-pieces, which enable a firm base to be obtained simply, as will be seen on reference to fig. 401.

Where the connection has to be made to a brick sewer, the brickwork must be cut out sufficiently to allow of the insertion of a properly-radiated highly-glazed fire-clay oblique junction-block, having square bed, sides, and top, as

shown in fig. 402, which must be set in cement mortar, and the brickwork made good thereto. In districts where the sewers are liable to be back-watered from tide-locking or the rise of floods, these junction-blocks should be fitted with a flap-valve, which will close with the pressure of the rising sewage in the main sewer, and so prevent the flooding of basements and the like. These valves have already been described.

The first stage in the work of construction is of course **the excavation of the trench** to the required depth. The trench should not be made wider than necessary to allow sufficient room for the pipe-layer to work. If it be over 10 feet deep it should be 3 feet wide, if the depth be less than that 2 feet 6 inches in width, and if it be no more than 4 or 5 feet deep, so that the earth can be thrown out without intermediate staging, a width of 2 feet 3 inches is sufficient. The surface-material should be carefully put on one side for reinstatement in its proper place, and the excavated material neatly and compactly deposited alongside the trench, so as to do as little damage and occasion as little inconvenience as possible; all

surplus rubbish must be removed promptly as the works proceed. In cutting through gardens and grounds the necessity of these conditions will be appreciated, and at the same time particular care must be taken to do as little damage as possible to the foliage and roots of trees and shrubs. The length of trench to be opened out at one time will be governed by the number of men constantly kept at work, the nature of the ground, and the interference with the proper use of and access to the premises. Where the trench is contiguous to walls and buildings, whose foundations may be liable to disturbance by reason of the trench being kept open an undue length of time, it should only be got out in short lengths, and the work rapidly completed and the trench refilled; this applies also in cases where the ground has been "made", the material being necessarily somewhat loose. If running sand be met with, the work should proceed cautiously in short lengths. Rock should be hewn out by hand, as

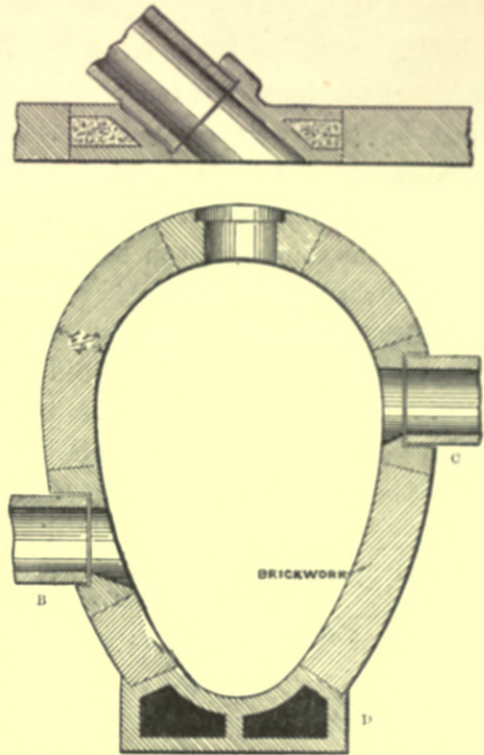

Fig. 402.—Junctions for Brick Sewer: B and C, junction-blocks; D, invert-block.

blasting is too risky in the immediate neighbourhood of property; when the trench, however, is at a safe distance from houses, blasting may be resorted to, provided the contractor takes the sole responsibility for accidents of every kind.

It is customary to open out trenches down to a depth of 16 feet. This requires three lifts or stages for getting the material up to the surface. The additional expense beyond this depth of having an extra lift, makes it cheaper to resort to **tunnelling**; but before this is done all the surrounding circumstances must be fully weighed and considered—that is to say, whether the ground immediately above the heading is sufficiently solid to admit of tunnelling, also whether due supervision can be exercised over the construction of the work, and whether the contractor can be relied upon to securely pack the heading so as to leave all thoroughly sound.

Where water occurs in the trench, proper provision must be made for its abstraction as the works proceed, by forming proper dams and sumps for the purpose, into which the suction-pipe of a pump must be inserted, care being taken to afterwards remove from the sump all wet and loose slurry, and to make good the hole with concrete up to the level of the pipes. In case any existing

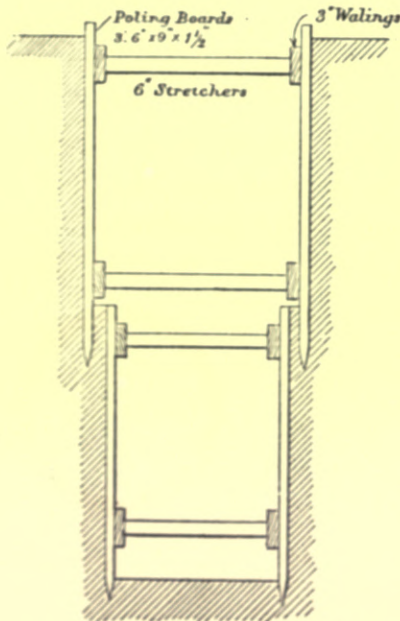

Fig. 403.—Method of Timbering Trench.

drains are met with, following the same course as the trench and likely to interfere with the progress of the new work, they must be diverted into temporary wooden troughs, and carried past the work as it proceeds to a temporary outlet, so as to avoid as far as possible any damage that might be caused to the bottom of the trench by the escape of water. Proper care must also be taken to maintain any drains which may come across the trench, cast-iron pipes being substituted for the pipes removed, of such a length that they will get a firm and even bearing on either side of the trench.

As the excavation proceeds, the sides of the trench should be supported by proper timbering fixed by "experienced and competent timbermen". Fig. 403 shows a cross-section of a trench fully timbered. The walings of 3-inch spruce planks are first set up and secured by stretchers of good strong square or round fir or (in narrow trenches) of larch. The poling boards are of elm or spruce, cut into 3-feet-6-inch lengths, with the toes sharpened and driven in with a mallet

behind the walings as close as the nature of the ground requires. The lower timbers are inserted in the same manner as the work proceeds. In case running sand is met with, the poling boards should be wedged close together and additional stretchers inserted, and behind the poling boards, litter, rushes, or bracken should be packed as tightly as possible, and added as required. Occasionally this running sand is so difficult to deal with that a second and inside course of poling boards is required to resist the pressure. The timber within each length of walings is called a "setting", and in difficult ground the work should proceed by settings, one being opened out as the preceding one is being filled up. This is naturally a costly process, but it is a safe one. In certain cases, to support property, some of the timber will require to be left in the trench, and where this is done, such timber should be accurately measured; but if the necessity for leaving it has arisen from carelessness or neglect on the part of the contractor, any timber so ordered to be left should not be paid for. The timbering should be strong enough to carry the staging necessary to hold the weight of material thrown up at each "lift" and the men working upon it. The stagings are usually from 4 feet to 5 feet apart vertically. Water and gas pipes and similar things will require supporting across the trench so as to prevent their fracture. These are sometimes slung to the top stretchers by chains, so that these walings must not be struck as the trench is being refilled. Extra timbering will likewise be required in the shoring up of walls and buildings.

Before laying the pipes, the trench must be neatly formed to the shape of the drain to be laid, proper socket-holes being cut so that each pipe may be truly and firmly bedded throughout its entire length, all irregularities resulting from bad workmanship being filled up with gravel or concrete. To obtain a true alignment of the pipes, the centre of the trench should be carefully notched on each sight-rail, and a stout cord connected to each mark from sight-rail to sight-rail. From this a plummet can be suspended over each pipe as required. Whenever the pipes require slightly raising so as to be true to the gradient, the packing must be done with the very finest material. If the foundation appears liable to give way when the trench is refilled a foundation of concrete should be formed, and carried up at least half the height of the pipes, so that these may be securely bedded in it, and the sides neatly bevelled as shown in fig. 404. The concrete must be lowered to the bottom of the trench in buckets, and properly placed in position; for if it is shot from the top of the trench, the stone will tend to separate from the mortar.



Fig. 404. — Concrete Cradle for Pipes.

Special care must be taken that drains are not laid in **newly-made ground**, as they are sure to subside along with it, thus fracturing the joints. The excavation in this kind of ground should be carried down to the solid earth, and a substantial wall of concrete or of dry rubble should be built up to the requisite level in order to ensure a firm foundation for the drain, and the pipes, after being placed in position and jointed, should be securely wedged on each side to prevent them rolling when the trench is being refilled.

After the pipes have been adjusted to the exact line and gradient, **the jointing of the pipes** should be proceeded with, according to whatever process is adopted, but no pipes should be covered up until they have been examined and tested for water-tightness. The drains should be kept as free as possible from rubbish and water during construction, and iron drains should always have every length brushed out before jointing, and upon completion they should all be cleansed and left entirely free from rubbish of every kind.

In refilling the trench, the best material should be selected to go in first—such as sand or fine gravel,—and this must be carefully placed and compactly rammed round the pipe without disturbing the line or fracturing the joint. When there is not less than a foot of cover over the pipes, the water used in testing may be let off, the discharge being observed in order to be sure that all the pipes were fully charged, and that the test was a fair one. The trench can then be refilled in layers not more than 9 inches thick, and well punned, two rammers following one filler, but no clay should be brought within 12 inches of the surface. The supports for gas and water pipes will require to be left until the trench has become quite consolidated. It is better not to reinstate the surface-materials immediately, but to cover off with good ashes or gravel. Settling will probably take place at the rate of 1 inch per foot in depth, even with the best rammed refilling, and with clay the rate will be even more, as it is very difficult to get it compactly together unless it has “fallen”. When consolidation appears to have been effected, the surface-materials should be reinstated and made good.

The first paragraph of By-law 62 prohibits **the passage of drains under buildings** except where no other mode is practicable, and the next paragraph prescribes that such a drain shall be laid in a direct line for the whole distance beneath the building, and be completely embedded in and covered with solid concrete at least 6 inches thick all round. It has already been pointed out that in certain cases, especially in town buildings, some drains must of necessity be laid under the building, and where there is no access to a back road the drains of terrace-houses are bound to be carried from back to front. It frequently

happens that where drains are laid under a building, through some failure of a joint the sewage escapes and runs underneath the pipes into the subsoil, causing very serious mischief indeed,—and this state of things is quite likely to occur even where the joints have been made in cement. It does not always follow that the drain should be laid under the floor of the basement; there are many instances in which economy may be practised by carrying the drain on brackets built into a wall of the basement, and thence into the road to be connected to the sewer. But it is obvious that earthenware pipes would not be suitable for a drain in such a position. Iron pipes only can be used; such pipes completed with a run-lead joint will not only convey the sewage adequately, but will be both water-tight and gas-tight. The fewness of the joints, and the rapidity with which they can be made, are very important advantages in favour of iron pipes, particularly when they have to be laid under a floor. Iron pipes, as they can be satisfactorily worked under pressure, may be of a smaller diameter than stone-ware pipes, provided no inlets are required for waste-pipes about the level to which the drain has to be laid.

This proposal of the Model By-laws **to embed the pipes in concrete** is a clumsy method, and it would be especially expensive to apply it in the case of an existing building on account of the excessive amount of material requiring to be got out, and also of the cost of the concrete, every ounce of which would have to be carried down in buckets from the outside, and in case a drain required relaying under business premises, the disturbance to business caused by the undue length of time taken up by such a process would be a serious matter. The proposal further leaves out of consideration any improvements which may have been effected in pipes themselves, or in the methods of jointing, during the last twenty years. I have myself had Hassall's double-lined-joint pipes laid beneath buildings, and seeing that such a joint can be made to stand a pressure of 100 lbs. to the square inch, it is surely safe enough in the interior of a building, more especially when the ground is covered with a layer of concrete before the floor is put down.

The further proviso in the model code for **adequate means of ventilation** to be provided in the case of a drain passing under a building is a right one, and no exception can be properly taken to it; if the terminal of the drain is not at a soil-pipe (which could be used for ventilating purposes), a special vent-pipe should in every case be provided.

CHAPTER VII.

FLUSHING, CLEANSING, AND TESTING DRAINS.

It is rightly considered that a scheme of town-sewerage cannot work satisfactorily without proper **arrangements for flushing the sewers**, the appliances for the purpose being placed at the head of all long sewers and at suitable intermediate positions. While town-sewers are laid at flatter gradients than house-drains, and the composition of the sewage is a great deal more complex, it is still necessary to have proper provision made for the flushing of house-drains. In

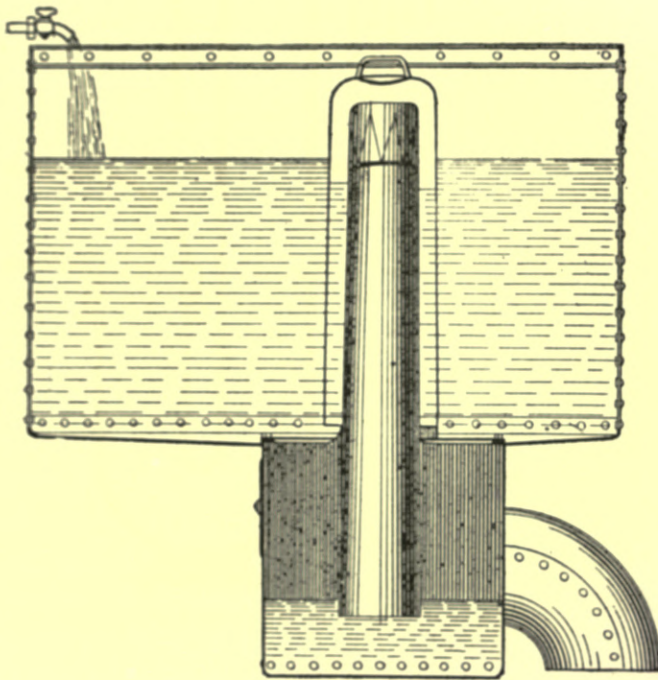

Fig. 405.—Section of Field's Annular Syphon.

many towns this work is now periodically done during the dry season by the sanitary authorities themselves, but in a well-devised system of house-drainage it is essential that some automatic appliance, regulated to discharge at suitable intervals, should be fixed at the head of the drain, for even if this is laid at a gradient that will produce a self-cleansing velocity, there are times when the flow of sewage is not sufficient to keep the solids from depositing, or to prevent their gradual accumulation and the consequent

generation of gases. The opening of a half-inch tap at full bore is of no value whatever. What is required is to discharge through the drain a volume of water sufficiently large to thoroughly cleanse the whole of the interior surface that has been in contact with the sewage.

Mr. Rogers Field was the first sanitarian to put into practical shape the principles of automatic drain-flushing, and his **self-acting flushing cisterns**, fitted with a patent annular syphon, have been in general use for many years; the present pattern is shown in fig. 405. The annular syphon is fitted into an iron tank. The longer limb of the syphon dips about $\frac{1}{4}$ inch into the water in the

lower tank or trapping-box, in which the water is kept at its proper level by a weir. The action is as follows:—When the water (fed from the inlet or tap) rises in the dome or bell to the top of the lip on the longer limb of the syphon, it begins to flow over by a succession of drops at first, which dispel a sufficient quantity of air in the discharge-pipe and bell to cause the level of the liquid within the bell to rise; this rise increases the overflow into the discharge-pipe and expels a further quantity of air, gradually forming a vacuum, which again causes a still larger rise and overflow, and thus brings the syphon into full action, when the tank is emptied with enormous rapidity.

Fig. 406 is an illustration of **Adams's flushing syphon**. When the tank, in which the syphon is placed, commences to fill, water stands in both legs of the inverted syphon at the level A. This level does not vary for a considerable time, because, although the tank is filling, the air imprisoned under the deep trap over the main pipe can escape by the small pipe at the side, which also has a cap over it. But when the water rises high enough to seal the upper end of this small pipe, the air is retained. As it becomes compressed, it forces down the water in the left leg of the syphon until this leg is empty. A further increase of pressure causes a large bubble of air to escape up the right leg. This

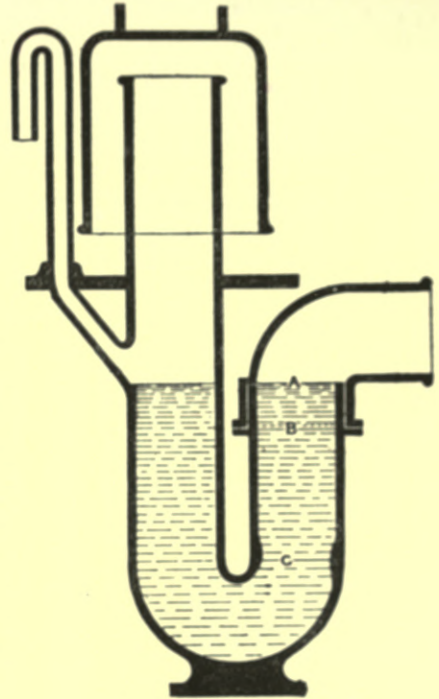

Fig. 406.—Section of Adams's Flushing Syphon.

leg, it will be seen, is contracted at c, so that the bubble is delivered up the centre of the pipe in one mass. Were it not for the restriction at c, it would be possible for the air to creep up the side of the pipe in small bubbles, when the effect would be less rapid and certain. As it is, as soon as the bubble turns the corner, it displaces a quantity of water in the right leg, and when it has passed away the level of water suddenly falls from A to B. The reduced head (B to c) can then no longer balance the air-pressure in the deep trap, and a rush of air clears out the syphon, to be immediately followed by all the water in the tank. To confine the requisite amount of air, a cap of sufficient depth is placed upon the vent-pipe shown, this pipe ensuring the absolute certainty of the apparatus giving free admission of air to the syphon both before and after its

discharge, in the latter case completely breaking the partial vacuum which otherwise would exist.

Fig. 407 shows a flushing syphon on a new principle, known as **Merrill's patent**. Instead of depending for its action on the gradually increasing pressure of the liquid in the tank driving out the air compressed in the syphon, Merrill's syphon depends on the action of a tipping bucket. When the water fed into the cistern or tank reaches the inlet end of the short leg, the air in the syphon

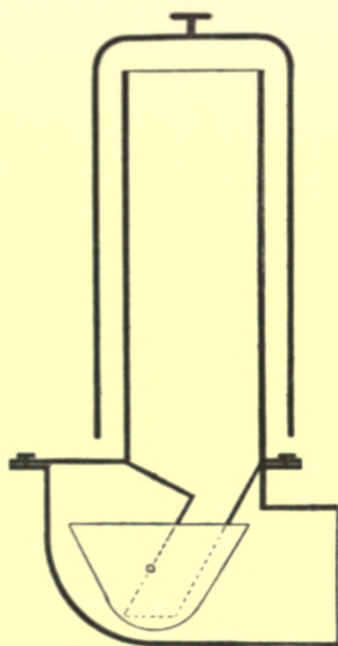

Fig. 407.—Section of Merrill's Patent Flushing Syphon with Tipping Bucket.

is locked up between the water in the tank and that in the outlet-trap, and consequently the water rises more slowly in the short leg than in the tank, the difference in level depending on the depth of the seal of the outlet-trap. When the feed supplied to the tank has produced a sufficient compression in the syphon, the air is gradually driven out through the trap, in proportion as the water rises in the tank and short leg. When the water reaches the bend or overflow point of the syphon, it overflows into the tipping bucket, which, when filled to its tipping point, overturns and throws out its contents into and through the outlet-trap, and thus produces a vacuum which permits the head of water to charge the syphon. The syphon is so constructed that the upper part can be lifted off, and the lower portion exposed for inspection or cleansing.

These syphon-cisterns, when charged with clean water, may be placed either inside or outside the house in any convenient position; but if outside and above-ground, means must be taken to protect them from frost. To economize in the consumption of water, it is a good arrangement to feed them from the bath-waste, as this water is seldom greasy; and as thirty gallons are often discharged from a bath, a cistern to hold this quantity is a suitable size to adopt in such a position.

Mr. Rogers Field has also devised another form of tank, which is shown in Fig. 408, called the "**Self-acting Flush-tank**", and which may be used in connection with sink-wastes. The apparatus consists of a cylindrical water-tight iron tank A, having a trapped inlet B, which also forms a movable cover to give access to the inside of the tank, and a socket c for a ventilating pipe. The outlet consists of a syphon DEF, so arranged that no discharge takes place till the tank is completely filled with sewage, when the syphon is brought into

action, and the contents are immediately discharged. The outer end *F* of the syphon dips into a discharging trough *G* attached to the flange of the syphon by a movable button *H*, so as to be turned round in the right direction to connect the tank with the line of the outlet-pipe *I*. This trough has a barrier *J* across it, with a notch so contrived as to assist small quantities of liquid in bringing the syphon into action, instead of merely dribbling over the syphon without charging it, as they otherwise would do. The cover of this trough can be removed to give access for cleaning. There is also a brass-wire strainer *K*, which is clipped on to the inner end *D* of the syphon, and can be taken off at will; and a screwed brass plug *L* is fitted to the bend *E* of the syphon, in case it should at any time be necessary to examine or clear it. The pipe *M* represents a waste-water pipe (usually from a sink), through which the supply of sewage is conveyed to the tank. Fig. 409 represents Field's flush-tank made in stoneware, which works in

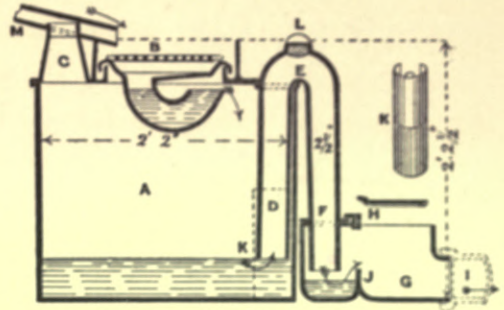

Fig. 408.—Section of Field's Self-acting Flush-tank.

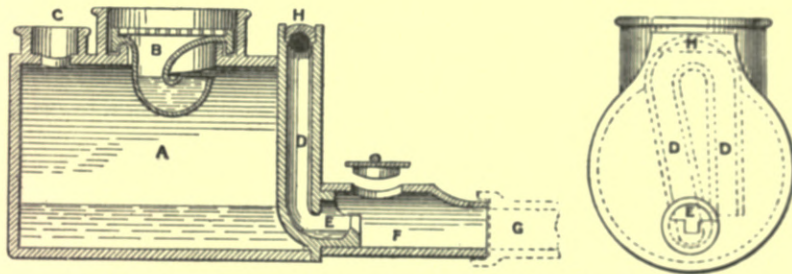

Fig. 409.—Section and End Elevation of Field's Stoneware Flush-tank.

the same manner as that made in iron, the only difference being that the syphon is placed in a different position.

This flush-tank must be fixed outside the house or building, and in some convenient position between the supply and the drain to be flushed, and the supply must be connected with the inlet and the drain with the outlet of the tank. There is no house in which there is not sufficient waste-water for flushing by means of this apparatus. The water from the sink is generally available as a supply, and the tank is specially adapted for this, as it forms the most perfect kind of trap, breaking the connection between the drains and the house, and intercepting the solid matter. Where the drains have only a slight fall, advantage can be taken of the height of the sink by placing the top of the tank above

the ground. The drippings from a water-tap, or the rain-water from the roof, may also be used as a supply. A very small accession of water will start the syphon when the tank is once full,

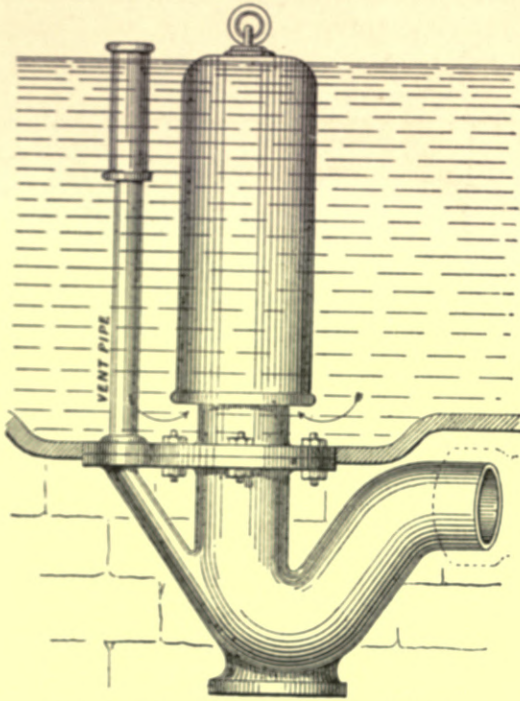

Fig. 410.—Adams's Glazed-ware Flush-tank, for Use with Waste-water.

but should it occasionally remain full for some time in consequence of insufficient supply, a jug of water, thrown on the grating of the inlet, will immediately set the syphon in action.

Adams's glazed-ware syphon, shown in fig. 410, can also be used for flushing house-drains with dirty water. It is made in any size from 3 gallons up to 40 gallons. It does not start with a dribble supply, but is filled with any house-waste (soil-pipe excepted), and when full, the addition of a little more—as by the emptying of a bowl or basin into the sink—at once sets up syphonic action, and the full contents of the vessel are discharged to the drain. In this also provision is made for cleansing by the cap, as the apparatus,

working with dirty or greasy water, requires periodical cleansing. A stone dish may be placed directly over the inlet, or a branch-drain may be connected thereto.

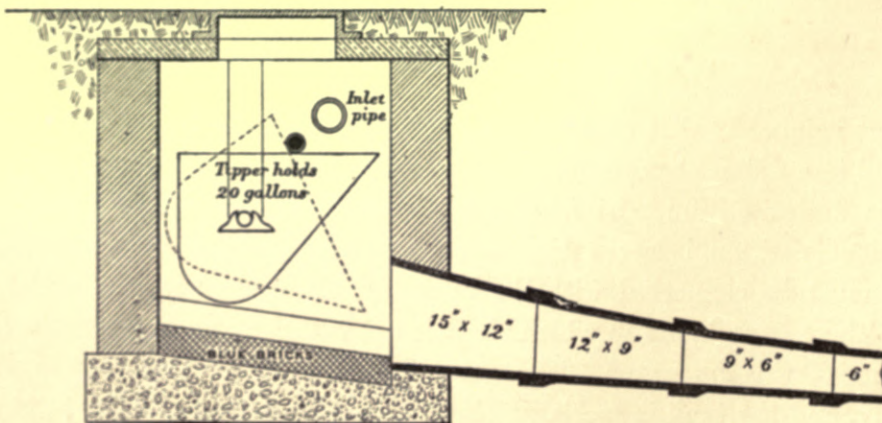

Fig. 411.—Duckett's Tipper used for Flushing Drains.

The tipper or tumbler, as used in connection with slop-water closets, can also be adapted for the purpose of flushing drains. For some years I had, at a house

in which I resided, a 5-gallon tipper fixed in the gully receiving the bath-waste, as shown in fig. 411. It worked well, and was very serviceable in keeping the intercepting trap, which was about twelve yards away, always sweet and clean. This tipper can be made in any size in fire-clay up to 60 gallons, but, being rather heavy, it is a somewhat delicate operation to set the tipper in a true horizontal position so as to maintain its balance; and the chamber in which it is fixed should be securely protected with a closed cover, so as to keep out any solid objects that would be liable to fall in and put the tipper out of gear.

For large houses and on long lengths of drains, a much larger quantity is required for flushing than can be economically stored in any of the appliances previously referred to, so that it is much more economical and satisfactory to **construct a tank of brickwork**, in which the flushing appliance can be placed. This brickwork should always be set in cement, and it would be

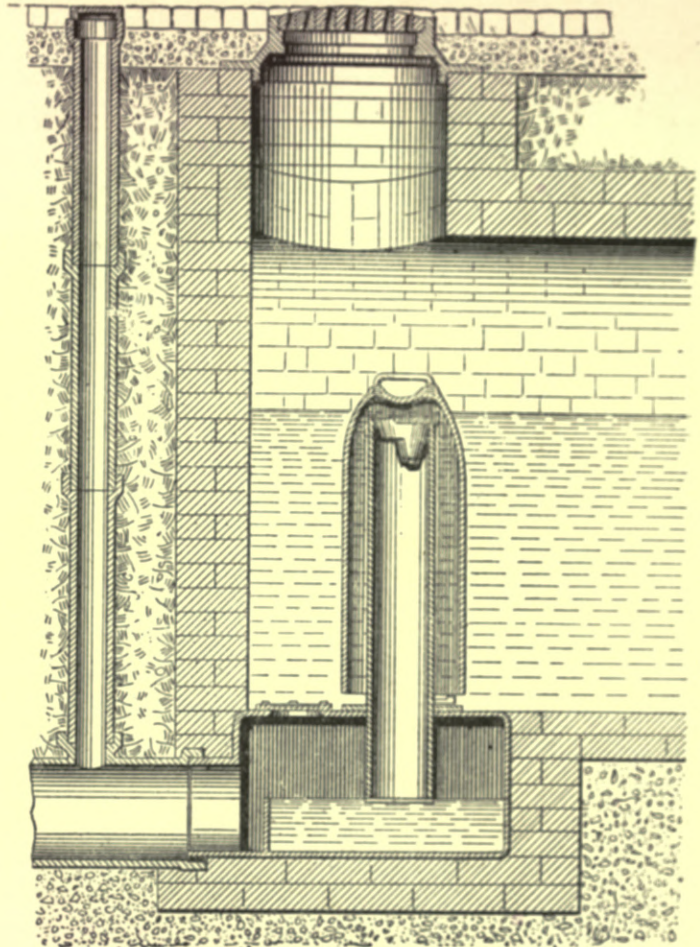

Fig. 412.—Field's Automatic Flushing Syphon in Brick Tank.

well to back it with well-tempered clay puddle as far as the top of the syphon-leg. The water may be taken from the house service-pipes, if a daily flush is required, or the overflow from any well, spring, or other private supply may be utilized, and, as far as possible, rain-water and the bath-waste. Fig. 412 shows a tank fitted with Field's syphon. Sometimes the trapping-box under the syphon is formed in concrete, but cast-iron, as shown in the illustration, is preferable. For a 6-inch drain, the depth of the syphon is 2 feet 2 inches, and for a 9-inch

drain 2 feet 7½ inches. Any of the other types of syphons previously described may be used in connection with these brick chambers. An arrangement has been designed by Messrs. Adams, so as to flush two ways, if desired.

The Miller syphon has lately been introduced into this country from America. The following description of it is taken from *Engineering*, February 1, 1895:—

“The flushing syphon is one which has been largely adopted in the United States, having obtained

the highest award at Chicago in 1893. Previous syphons have been brought into action by the simple release or rarefaction of the air confined in the syphon, or by the sudden removal of such air by special subsidiary devices, which are entirely absent in the ‘Miller’ syphon.” As shown in fig. 413, “it consists of two simple castings, a U tube (or

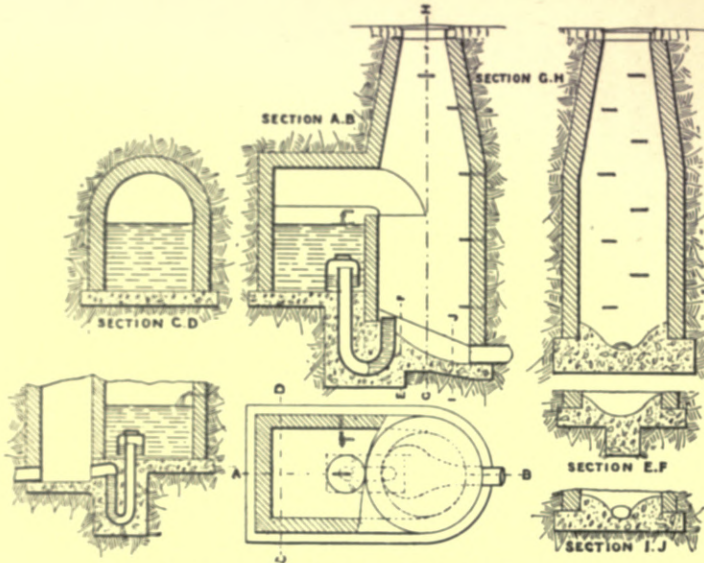

Fig. 413. - Details of the Miller Syphon in Manhole.

trap) and mouthpiece, cast in one piece, and a cast-iron bell which is placed over the longer leg of the syphon, and is held in place by brackets cast on the trap. The action of the syphon is as follows: As the water entering the tank rises above the lower edge of the bell, it encloses the air within, the lower portion of the U or trap being, of course, filled with water. As the water-level in the tank rises, the confined air gradually forces the water out of the long leg of the trap, until a point is reached when the air just endeavours to escape round the lower bend. Now, as the difference of water-level in the two legs equals the difference of the levels between the water in the tank and the water within the bell, it will be seen that the column of water in the short discharge-leg has practically the same depth as the head of water in the tank above the level at which it stands in the bell. The two columns of water therefore counterbalance each other at a certain fixed depth in the tank. As soon as this depth is increased by a further supply, however small, a portion of the confined air is forced around the lower bend, and by its upward rush carries with it some of the water in the short leg, thus destroying the equilibrium. But the secret of this invention is the free

projection of the overflow edge, which allows of the instantaneous escape or falling away of the heaved-up water. Thus, if the discharge-mouth were formed as an ordinary bend, the syphon would not act (although the confined air rushes around the lower bend), for the simple reason that the heaved-up water has no means of instantaneous escape, and therefore the equilibrium is not sufficiently disturbed. It will thus be seen that the action of the syphon depends not on the escape of air, but on the sudden reduction of a counterbalancing column of water.

Repeated trials have shown that a 6-inch Miller syphon will discharge full-bore a 500-gallon tank, fed so slowly as only to be filled in fourteen days. There being no internal obstruction, the discharge is extremely rapid. There is, it will be seen, a deep-water well between the flushing tank and the sewer, which is of course an advantage. We have had the opportunity of seeing one of these syphons at work in the excellent sanitary museum at Hornsea, and though severely tried, the syphon worked perfectly. As will be seen by a reference to fig. 413, the syphon-chamber can be very neatly combined with a manhole. No special mouth-piece is required; the mouth of the discharge-pipe stands quite clear, and delivers the water into a concrete basin, from which it rushes down into the sewer."

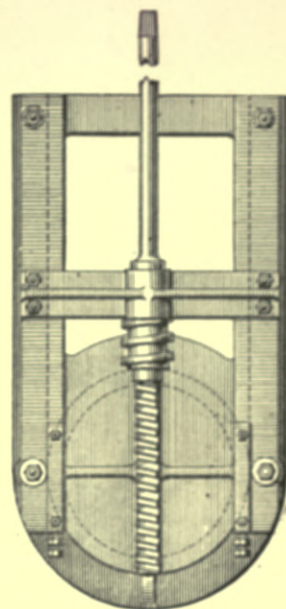

Fig. 414.—Screw-down Penstock.

In long lengths of drain it is not necessary to go to so great an expense as would be occasioned by the construction of intermediate flushing tanks, but it is sufficient to re-use water discharged from the flushing tank at the head of the drain, and this can be accomplished by fixing **penstocks in the manholes**; when the penstocks are securely closed, the sewage or water is dammed back in the sewer, and when the penstock is opened again, the liquid rushes forward with great force. The "screw-down" penstock, shown in fig. 414, is raised or lowered by a key fitted on to the top of the spindle from the surface. This type of penstock is the most suitable where absolute water-tightness is desired, and where the pressure behind it is considerable; but there are circumstances where a penstock of the disc pattern, as shown in fig. 415, would answer the purpose. This, as will be seen, is self-locking, and works from a side pivot, and is raised or lowered by working the spindle attached. Whenever a penstock is fixed in a manhole, it is desirable, on account of the sudden rush of water when the penstock is raised, which is apt to rise over the invert on to the platform at the

side of it, that the outgo of the manhole should be enlarged into the form of a swallow, or shoot (as it is sometimes called), as shown in fig. 416. For some

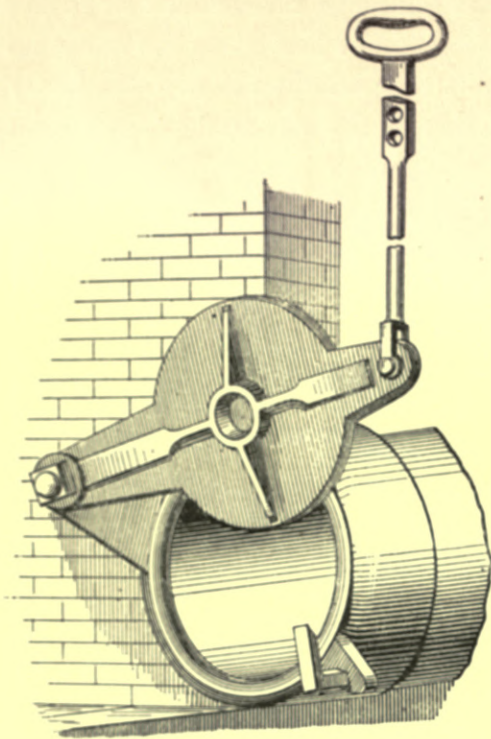

Fig. 415.—Disc Penstock.

years I have made it a practice in fixing a penstock to place a relief-pipe from the drain immediately behind the wall of the manhole, turning it over into the manhole at a level that will prevent the escape of sewage on to the surface of the ground through the gullies or manhole-gratings farther up the drain, in case any accident should prevent the penstock from being raised. I have generally found that gardeners and other servants, who are set to attend to the flushing of drains, have a knack of going away in the middle of the operation and of forgetting to raise the penstock. The relief-pipe also acts as an escape for the air displaced by the incoming body of water. A penstock should always be fitted upon the inlet-pipe of the intercepting manhole, as it will be found not

only useful for drain-cleaning purposes, but also whenever it is desired to apply the hydraulic test to the drains.

It may be thought that, if drains are constructed upon the conditions already

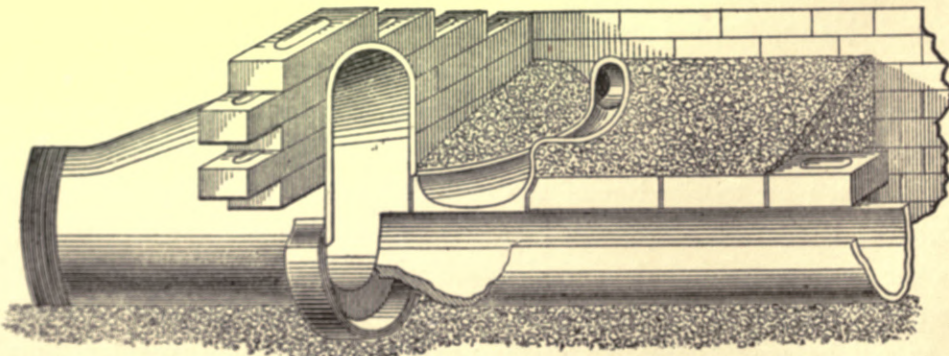

Fig. 416.—Drain Shoot for Use with Penstock.

laid down, and if proper attention is paid to their maintenance, there is no possible chance of their getting stopped up. I am not one of those who believe

that all drains get stopped sooner or later, but I have found **stoppages in drains** within a few months of their completion—in one instance caused by a house-
maid's scrubbing-brush; another stoppage was found to have been caused by one
of the masons having swept into the drain a quantity of stone from a manhole
cover at which he had been working; in another case, at a public institution, I
found the drain completely

blocked with pieces of floor-
cloth, and the lint from
them, and also an excessive
quantity of grit from rub-
bing stones. For the last
case, a successful remedy
was found by placing a
strong galvanized-wire
strainer across the invert
of one of the manholes. It
is clear that temporary
stoppages in drains do
occur, and for the purpose
of removing them, the best
implements are the red
malacca canes, cut into
lengths varying from 2 to
6 feet, and fitted with in-
terchangeable brass screws
and brass riveted; they can
be procured in bundles

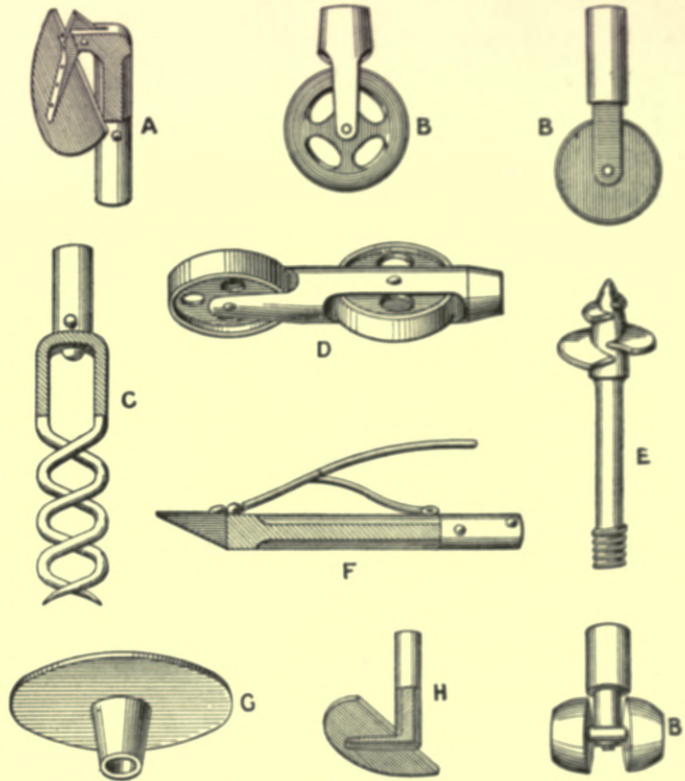

Fig. 417.—Drain-clearing Tools.

from 30 to 100 feet in length, and a number of tools used for removing an
obstruction can be screwed on as required. These tools consist of a duplex
clearing roller, double spiral screw, Archimedean screw, whole scraper, half
scraper, and half drop-scraper, borer, plunger, and wheels, all of which are shown
in fig. 417. Brushes either of bass or whalebone, similar to a chimney-sweeper's
brushes, should be used for finally sweeping out the drain.

It is desirable and necessary to **apply a test to drains** to ascertain whether
the joints remain water-tight, and that no sewage is escaping. Some few years
ago there was quite a craze for testing drains by the smoke-test. While this has
certain advantages inside a house, it is absolutely valueless for discovering the
unsoundness in an external drain. The only reliable way to test a drain is by

the application of water-pressure. This is done—where there are no penstocks—by stopping up the lower end of the drain with a plug, so as to make it absolutely water-tight, and at the higher end a bend and two lengths of pipe should be placed temporarily so as to secure a sufficient head of water. The drain should then be filled and allowed to stand for (say) two hours, during which time the behaviour of the water in the vertical stand-pipe should be noticed; if there should be any subsidence, a leakage will have taken place at one of the joints, which should be searched for, and, when discovered, made

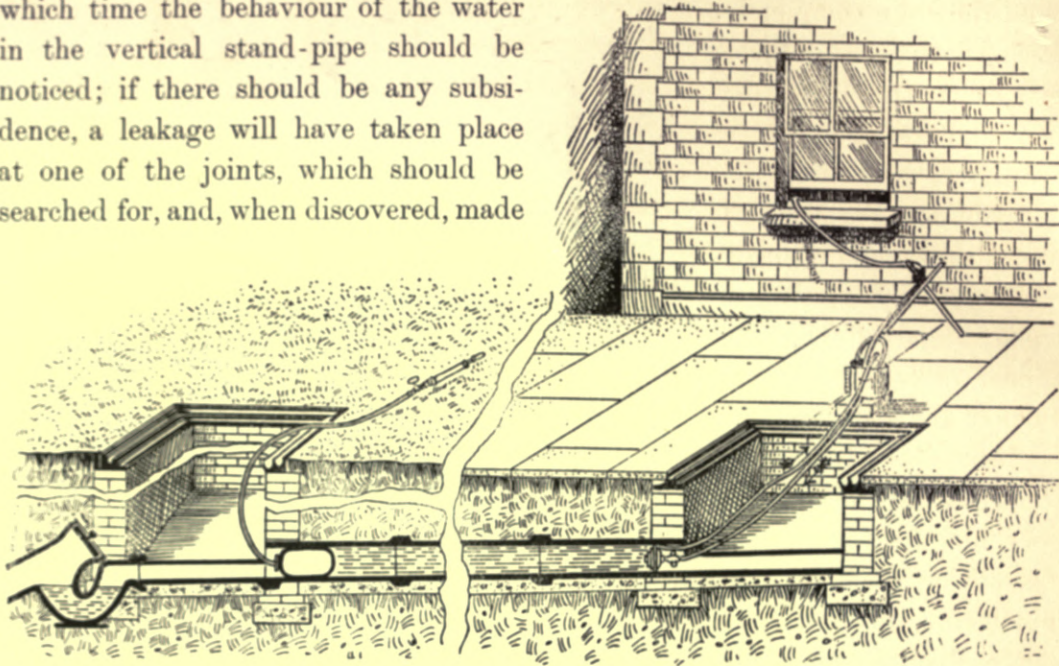

Fig. 418.—Jones's Apparatus for Testing Drains with Water.

good. In fig. 418 Jones's apparatus is shown, in which a plug is inserted at the head of the drain, instead of the bend and stand-pipe just described.

There are several kinds of **drain-stoppers**; the one shown in fig. 419 is Jones's bag stopper. This invention consists of a cylindrical bag, to which is attached 6 feet of flexible tube, with a tap at the end connected to a small hand-pump. The bag is placed in the drain before inflation, and by working the pump it is quickly filled with air under sufficient pressure to dam the drain and prevent any escape of water. By turning the air-tap, the inflated bag remains in that state as long as required, and when done with, a half-turn of the tap again releases the air, and the bag is withdrawn. Amongst its advantages may be

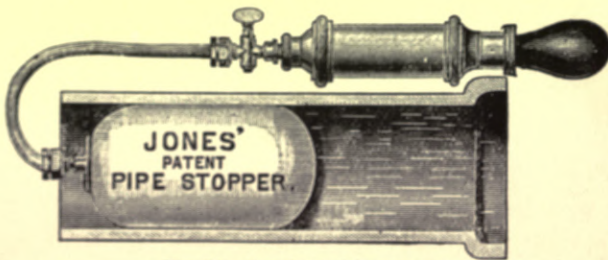

Fig. 419.—Jones's Bag Pipe stopper.

named lightness and flexibility, enabling it to be folded and carried in a small compass, and it can be placed in syphons, gullies, and other traps.

Mr. Jones is also the patentee of another stopper called the "Screw Expanding Stopper", which is shown in fig. 420. This stopper consists of two plates or discs of galvanized iron, between which a special hollow rubber ring is fixed by means of grooves. It is screwed up by a key, which causes the rubber to expand outward to the extent of from one inch in the smaller sizes to three inches in the larger sizes. This will be found sufficient to plug any pipe according to the size of stopper used. This stopper can be obtained with a central outlet fitted with a patent connector, to which a glass indicator is attached, so that the fall of the water in the drain can be accurately gauged, and the slightest leakage detected.

Fig. 421 shows a general view and section of the "Grip" plug, patented by Mr. Milton Syer, and fig. 422 shows a section of the "Addison" stopper. The parts of the latter are non-corrosive, the disc being of galvanized iron, the nipple of gun-metal, and the nut and cap of brass. The rubber in contact with the pipe is shown at A A. The lip C is made in such a form that the pressure of water acting upon it tends to make the joint more

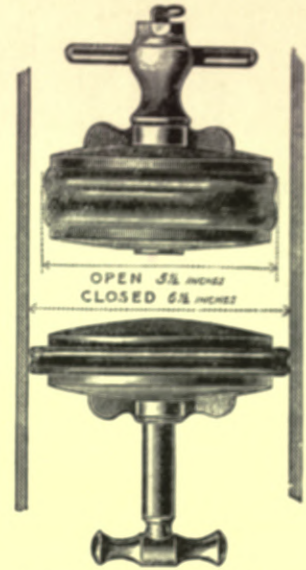

Fig. 420.—Jones's Screw Expanding Pipe stopper.

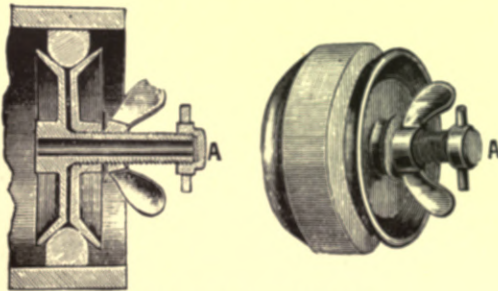

Fig. 421.—Syer's "Grip" Plug.

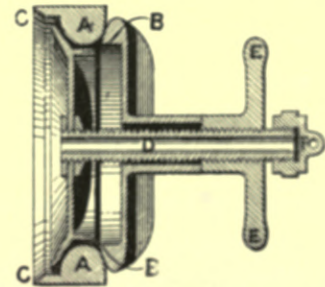

Fig. 422.—The "Addison" Drain-stopper.

secure. The rubber cannot pinch between the two discs, being held in position by the guide B. These stoppers expand about $\frac{1}{2}$ inch, thus making them perfectly tight, and allowing for variation of size in different makes of pipes. The expanding is easily done by screwing the nut, which is provided with long wings E. The stopper is fitted with an inside tube D, sealed by a screw-cap F, which, when unscrewed, allows the water to escape after being used for testing.

Price's patent Combination Drain-testing Block is another good invention, and consists of a number of metal and rubber rings, so arranged that a 4-inch, 6-inch, or 9-inch drain can be tested. It is shown in fig. 423. It is made of polished brass with special rubbers, and is very durable and compact.



Fig. 423.—Price's "Combination" Drain-testing Block.

However well-arranged and well-constructed a system of house-drainage may be, it is of the utmost importance that there should be **periodical inspection and examination** to ascertain that everything is in proper working order. All intercepting traps should be examined to see that they are free from deposit, and the pits of all gullies should be regularly emptied, and in the case of surface-water gullies, should in periods of dry weather be replenished with clean water at frequent intervals.

There is a general indifference on the part of occupiers of houses to these things; drains being out of sight are most often out of mind so long as no inconvenience is felt from any odours which may be given off from them.

The occupier of every house, on taking possession, should make himself thoroughly acquainted with the course of all the drains, and the position and working of all the appliances in connection therewith. It is sometimes very difficult to get any reliable knowledge about the drainage-system of a house, as the work may have been done without any plan at all, and one is frequently referred to some old servant or foreman who happened to be about at the time they were put in. It is very unfortunate that reliable and accurate plans of all systems of house-drainage are not filed and kept at the office of the District Council for reference. It is true that plans of the drains of all new property, which may have been erected since the By-laws were adopted, are so kept, but even in these cases they are not altogether to be relied upon, as alterations may have been made in carrying out the work. The plan of the work as completed is what is required, and not a plan of what was contemplated, and in the case of subsequent alterations, all extensions and amendments of the system should always be carefully recorded.

It is not the custom in this country for the person letting a house to give any **warranty as to the condition of the drains, &c.** It is the duty, therefore, of the intending occupier to satisfy himself as to the sanitary condition of the house that he proposes to take, and failing—as will often be the case—access to any reliable

plan or history of the scheme, he must call in an expert to advise him in the matter. Having taken the house, it would be a good thing if the mistress would make herself acquainted with the scheme of drainage, so that she could instruct workmen or servants how to attend to any little temporary derangement, whenever it should occur during her husband's absence.

END OF VOLUME I.

IA • VANVM • LABORAVERT • QVI • ÆDIFICANT

