

EX LIBRIS

MECHANICS DEPT.

Engineering
Library

INTERNET ARCHIVE

Digitized for Microsoft Corporation
by the Internet Archive in 2007.

From University of California Libraries.

May be used for non-commercial, personal, research,
or educational purposes, or any fair use.

May not be indexed in a commercial service.

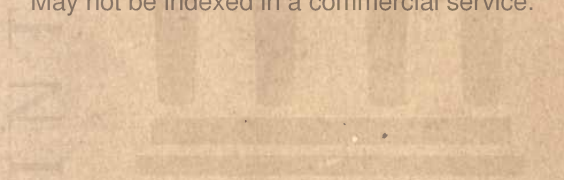

ELECTRICAL MACHINERY

McGraw-Hill Book Co. Inc

PUBLISHERS OF BOOKS FOR

Coal Age ▽ Electric Railway Journal
Electrical World ▽ Engineering News-Record
American Machinist ▽ Ingeniería Internacional
Engineering & Mining Journal ▽ Power
Chemical & Metallurgical Engineering
Electrical Merchandising

ELECTRICAL MACHINERY

A PRACTICAL STUDY COURSE

ON

Installation, Operation and Maintenance

BY

F. A. ANNETT

*Associate Editor, Power; Member, American Institute of
Electrical Engineers; Associate Member, Association
of Iron and Steel Electrical Engineers*

UNIV. OF
CALIFORNIA

FIRST EDITION

SECOND IMPRESSION

McGRAW-HILL BOOK COMPANY, Inc.

NEW YORK: 370 SEVENTH AVENUE

LONDON: 6 & 8 BOUVERIE ST., E. C. 4

1921

Univ Calif - Digitized by Microsoft®

TK 2182
A6

Engineering
Library

Mechanics Dept

COPYRIGHT, 1921, BY THE
McGRAW-HILL BOOK COMPANY, INC.

PREFACE

During the three years from January, 1917, to December, 1919, there was published in "Power" a series of articles on practical electricity under the title, "The Electrical Study Course." For the first eighteen months the author of this book wrote the Electrical Study Course Lessons, and during 1919 edited them. After many requests for these lessons in book form, he was induced to compile these articles into a volume which this work represents. An effort has been made to include such material as would make the work not only of value as a study on elementary theory of electricity and magnetism, but of practical worth.

The first eighteen months of the Electrical Study Course Lessons have been used almost as they appeared in "Power," and also parts of the lessons during the following eighteen months. In addition to this there has been incorporated a number of articles by the author on electrical-machinery operation and connections and kindred subjects, which have appeared in "Power" during the last seven or eight years.

In the author's fifteen years' experience in teaching industrial electricity, directing men on the job and in editorial work, it has been found that there are many features in the study of electricity that a large percentage of home students and those taking short courses find to be stumbling blocks. They get wrong conceptions of the theory or find it difficult to get a clear understanding of certain elementary laws. In the preparation of this material an effort has been made to present the subjects in such a way as to guide the student over these pitfalls and to have all the problems deal with things that the practical man comes in contact with in his

daily work, so as to show how theory fits into practice. Although there are available a number of good books on elementary electricity and magnetism, the demand for the Study Course Lessons in book form has been interpreted as a justification for this volume, and it is presented with the hope that it has a real field of usefulness.

The author takes this opportunity to express his very deep personal appreciation of Mr. Fred R. Low, Editor in Chief of "Power," for his constructive suggestions and inspiration, which has made this book possible. He also desires to acknowledge with thanks the work of Mr. W. A. Miller, who wrote the Electrical Study Course Lessons during the last eighteen months they were published.

F. A. ANNETT

New York City,
March, 1921.

CONTENTS

	PAGE
PREFACE.....	v to vi

CHAPTER I

INTRODUCTION—FUNDAMENTAL PRINCIPLES.....	1 to 9
Electricity.—Sound Analogy.—Heat Analogy.—Light Analogy.—Electricity Similar to Heat, Sound and Light.—Electrical Generating System.—How Electric Pressure is Varied in a Wire.—What Happens when Current Flows in a Wire.—Magnetic Effects of an Electric Current.—Magnetic Field Varies with the Current.—Causes Changing Direction of Current.	

CHAPTER II

ELEMENTARY MAGNETISM.....	10 to 28
Discovery of the Property of Magnets.—Artificial Magnets.—Permanent Magnets.—Properties of Magnets.—The Earth a Magnet.—Poles of a Magnet.—Distribution of Magnetic Field.—Lines of Force Conventional.—Unit Magnetic Pole.—How Magnets Attract Pieces of Iron.—Why Iron can be Magnetized.—Theory of Magnetism.—How Magnets are Demagnetized.—Electricity and Magnetism.—Direction of Magnetic Field About a Conductor.—Relation Between Direction of Current and Magnetic Field.—Determining Direction of Magnetic Field About a Conductor.—Magnet Field Around a Number of Conductors.—Properties of Electromagnets.	

CHAPTER III

FUNDAMENTALS OF THE ELECTRIC CIRCUIT.....	29 to 48
Production of Voltage.—Electric Pressure and Temperature.—Unit of Electric Current.—Electrical Resistance.—No Perfect Insulator of Electricity.—Pump Analogy of Electric Circuit.—Measurement of Pressure.—Measurement of Current Flow.—How to Increase Voltage.—Pump Analogy of Voltage Sources in Series.—How Current is Increased.—Pump Analogy of Current Sources in Parallel.—Series-Parallel and Parallel-Series Connections.	

CHAPTER IV

	PAGE
OHM'S LAW, SERIES AND PARALLEL CIRCUITS.....	49 to 72
Three Electric Units.—Unit of Electric Current.—Relation Between Volts, Amperes and Ohms.—How to Remember Ohm's Law.—Electric Generator.—Factors that Influence Flow of Electric Current.—Ohm's Law Problems.—What Constitutes Electrical Resistance.—Series Circuits.—Flow of Electric Current Compared to Water Flowing Through a Pipe.—Voltage Drop Along a Circuit is Similar to Pressure Drop in a Pipe Line.—The Value of the Volts Across Each Section of Resistance in Any Circuit May be Found by Ohm's Law.—Parallel Circuits.—The Total Resistance of Any Circuit is Equal to the Total Voltage Divided by the Total Current.—Joint Resistance of Two or More Unequal Resistances in Parallel.—Resistance and Conductance.—Formula for Finding Joint Resistance.—Hydraulic Analogy of a Parallel Circuit.—Two Methods of Working Out Joint Resistance Problems.—Volts Drop Across a Circuit.—Determining Value of Current by Volts Drop and Resistance of Section of a Circuit.	

CHAPTER V

ENERGY, WORK AND POWER.....	73 to 81
Energy the Ability of Doing Work.—Steam Under Pressure Possesses Energy.—Foot-Pound Unit of Work.—Defining Unit of Power.—Definition of Energy, Work and Power.—Horse-power Defined by James Watt.—When Energy is Expended Heat is Produced.—Mechanical Equivalent of Heat.—British Thermal Unit.—Power of an Electric Circuit.—Heat Equivalent of an Electric Current.	

CHAPTER VI

COMPLEX CIRCUITS AND EFFECTS OF INTERNAL RESISTANCE.....	82 to 92
Circuits in Which Elements are Grouped in Series and Parallel.—Internal Resistance.—How to Compute Value of Current when Effect of Internal Resistance is Considered.—Volts Drop in a Source of Electromotive Force.—Volts Drop Through Resistance of Armature.—Effects of Increasing the Load on Batteries.	

CHAPTER VII

ELECTRICAL INSTRUMENTS.....	93 to 106
Principles on which Electrical Instruments are Constructed.—Movement for Modern-Type Instrument.—Instrument Connected as Voltmeter.—Turning Effort Proportional to the Current in the	

Coil.—Not Voltage that Causes the Coil to Move, but Current.—
Instrument Connected to Measure Current.—Instrument to
Measure Both Volts and Amperes.—Direct-Reading Wattmeter.—
Watt-Hour Meter.

CHAPTER VIII

METHODS OF MEASURING RESISTANCE..... 107 to 116
Voltmeter-and-Ammeter Method.—Known-Resistance Method.—
Measuring High Resistance.—Measuring Insulation Resistance.—
The Wheatstone Bridge.—Hydraulic Analogy of a Wheatstone
Bridge.—Condition to Give Balanced Pressure.

CHAPTER IX

CALCULATING SIZE OF CONDUCTORS..... 117 to 132
Wire Gage for Round Wire.—Circular Mil as a Unit of Measure-
ment.—Some Features of the Wire Table.—Wire-Number Sizes.—
Cross-Section and Diameter of Round Conductors.—Wire Table
Worked Out from No. 10 Wire.—Allowable Carrying Capacities
of Copper Wire.—Allowable Voltage Drop.—Economical Size of
Conductors.—Voltage Regulation of Different Circuits.—Calculat-
ing Size of Conductors.—Derivation of Circular-Mil Formula.—
Resistance per Foot of Conductor.

CHAPTER X

FUNDAMENTAL PRINCIPLES OF DYNAMO-ELECTRIC MACHINERY... 133 to 15
Electromagnetic Induction.—Rule for Determining Direction of
Electromotive Force.—Lines of Magnetic Force.—Unit Electro-
motive Force.—Fundamental Principle of the Electric Motor.—
Direction Conductor Will Move in a Magnetic Field Depends upon
the Direction of the Current.—Counter-Electromotive Force.—
How an Electric Generator is Loaded.—Simplest Form of Electric
Machine.—Factors Governing Value of the Voltage.—Current
Reverses in External Circuit.—Electromotive Force or Current
Curve.—Machine with Ring-Type Armature.

CHAPTER XI

DIRECT-CURRENT MACHINERY CONSTRUCTION..... 152 to 169
Types of Armature.—Objections to Ring-Type Armatures.—
Drum-Type Armatures.—Effects of Eddy Currents.—Eliminating
Eddy Currents.—Objection to Smooth-Core Armatures.—Field
Magnets.—Early Types of Field Magnets.—Consequent-Pole
Type Machine.—Materials Used in Field Poles.—Function of
the Commutator.—Commutator Construction.

CHAPTER XII

	PAGE
INDUCTANCE AND COMMUTATION.....	170 to 181
Magnetic Field About a Conductor.—Voltage Induced by Decreasing Current.— Mutual Inductance.— Self-Inductance.— Neutral Point on Commutator.—How Voltage in Armature is Maintained Constant.—Effects of Self-Induction on Commutation.—Commutation Period Short.	

CHAPTER XIII

TYPES OF DIRECT-CURRENT GENERATORS.....	182 to 202
Exciting Field Coils of Direct-Current Generators.—How Voltage is Built up in the Armature.—Lines of Force in Field Poles Does Not Increase in Proportion to the Current Flowing in the Field Coils.—Field-Coil Connections and Armature Rotation.—Reversing Rotation of Armature.—Series-Connected Generator.—Ampere-Turns on Field Poles.—Load on a Series Generator.—Voltage Control on Shunt Generator.—Diagrams of Direct-Current Generators.—Effects of Loading a Shunt Generator on Voltage Regulation.—How Voltage May be Maintained Constant.—Compound-Wound Generator.—Crossing Field Connections of Compound-Wound Generator.	

CHAPTER XIV

DIRECT-CURRENT GENERATOR CHARACTERISTICS.....	203 to 214
Voltage Curves of Shunt Generator.—Volts Drop in Armature with Fields Separately Excited.—Voltage Curve of Series Generator.—External Characteristic Curves.—Voltage Curve of Compound Generator.—Series Winding to Compensate for Volts Drop in Armature.—Voltage at Terminals of Compound Generator.—Proper Amount of Compounding.—Compounding Shunt.—Short-Shunt and Long-Shunt Connections.	

CHAPTER XV

LOSSES IN DIRECT-CURRENT MACHINERY.....	215 to 221
Loss in Transformation of Energy.—Friction Losses.—Current to Excite the Field Coils.—Copper Losses in the Armature.—Eddy-Current Losses.—Hysteresis Losses.—Total Losses in an Electric Machine.	

CHAPTER XVI

DIRECT-CURRENT MOTORS.....	222 to 232
Fundamental Principle of Electric Motor.—Effects of Changing Brush Position.—Another Theory of Motor Operation.—Both	

Motor and Generator Action Present in all Dynamo-Electric Machines.—Counter-Electromotive Force.—How Motor Operates When Loaded.—How Speed of Motor may be Adjusted.

CHAPTER XVII

TYPES OF DIRECT-CURRENT MOTORS. 233 to 246
 Five Types of Motors.—Torque of Series Motor Varies as the Square of the Current.—Shunt-Type Motors.—Torque of Shunt Motor Varies as the Armature Current.—Compound-Type Motors.—Effects of Armature Reaction.—Commutating-Pole Machines.—Number of Interpoles Used.—Motors with Compensating Windings.

CHAPTER XVIII

STARTING RHEOSTATS AND CONNECTIONS TO DIRECT-CURRENT MOTORS. 247 to 268
 Starting Resistance.—Action Taking Place when Motor is Started.—Starting-Current Curve.—Starting Boxes.—Connecting Up a Series Motor.—Connecting Up Shunt Motors.—Mistakes in Making Connections.—Checking Connections.—Connecting Up Compound Motor.—Testing Polarity of Series and Shunt-Field Windings.—Reversing Direction of Rotation.—Connecting Up Interpole Machines.

CHAPTER XIX

THREE-WIRE SYSTEMS AND HOW THEY MAY BE OBTAINED. 269 to 289
 Voltages for Direct-Current Circuits.—Three-Wire System.—Balancer Sets for Three-Wire Systems.—How Balancer Set Maintains Three-Wire Systems Voltage Balanced.—Compound-Wound Balancer Sets.—Three-Wire Generators.—Power Output of Three-Wire Generator.

CHAPTER XX

DIRECT-CURRENT GENERATORS IN PARALLEL. 290 to 306
 Reasons for Operating Generators in Parallel.—Effects of Generator Characteristics on Parallel Operation.—Compound Generators in Parallel.—Equalizer Connection.—Putting Generators into Service.—Parallel Operation of Three-Wire Generators.

CHAPTER XXI

FUNDAMENTAL PRINCIPLES OF ALTERNATING CURRENT. 307 to 321
 Dynamo-Electric Machines Fundamentally Generate Alternating Current.—Distance Traveled and Rate of Motion.—Principles of the Dynamo-Electric Machines.—Alternating Electromotive Force.

—Electrical Degrees.—A Number of Conductors Connected in Series Generating Voltage.—Relation Between Cycles, Poles and Speed.

CHAPTER XXII

MEASUREMENT AND ADDITION OF ALTERNATING VOLTAGES AND CURRENT..... 322 to 332
Instruments for Alternating-Current Circuits.—Voltmeter and Ammeter Readings.—Addition of Voltages and Currents.

CHAPTER XXIII

TWO-PHASE AND THREE-PHASE CIRCUITS..... 333 to 349
Two-Phase Systems.—Three-Wire Two-Phase Systems.—Three-Phase Systems.—Three-Phase Machine with Ring Armature.—Delta and Star Connections.

CHAPTER XXIV

OPERATING ALTERNATORS IN PARALLEL..... 350 to 362
Condition for Parallel Operations.—Adjusting Load on Two or More Alternators.—Putting an Alternator into Service.—Other Methods of Synchronizing.—Electro-Dynamometer Type of Synchronoscope.—Synchronoscope Connections.

CHAPTER XXV

KILOWATTS, KILOVOLT-AMPERES AND POWER FACTOR..... 363 to 375
How Current Builds Up in a Direct-Current Circuit.—Lenz's Law.—Current Lags Behind Voltage.—Pump Analogy of Alternating Current.—Apparent Watts and Useful Watts.—A Wattmeter Reads True Watts.—Power in an Alternating-Current Circuit.—Effects of Capacity.—Power of Polyphase Circuits.

CHAPTER XXVI

POTENTIAL AND CURRENT TRANSFORMERS..... 376 to 385
Types of Potential Transformers.—Principles of Transformer Operation.—Core-Type and Shell-Type Transformers.—Relation of Primary and Secondary Volts.—Grouping of Transformers.—Current Transformers.

CHAPTER XXVII

ALTERNATING-CURRENT MOTORS..... 386 to 401
Parts of an Induction Motor.—Revolving Magnetic Field.—Relation Between Poles, Frequency and Speed.—How Rotation is Pro-

	PAGE
duced.—Rotor Must Run Slower than the Magnetic Field.—The Induction Generator.	

CHAPTER XXVIII

STARTING POLYPHASE MOTORS.....	402 to 420
Wound-Rotor Induction Motors.—Types of Rotors.—Wound-Rotor Motors that Start Automatically.—How to Reverse the Direction of Rotation.—Comparison of Squirrel-Cage and Wound-Rotor Motors.—How Auto-Transformers Operate.—Starting Compensators for Polyphase Motors.—Rheostats for Starting Polyphase Motors.—Starting Two or More Motors from the Same Compensator.	
INDEX.....	421

ELECTRICAL MACHINERY

CHAPTER I

INTRODUCTION—FUNDAMENTAL PRINCIPLES

Electricity.—The object of this introduction is to give a clear conception of the electric current and its fundamental actions as used in commercial electrical machinery. It will be confined to a pictorial description rather than a mathematical analysis or study of the laws of electricity, because it will be easier for the student to understand the operation of the machinery that will be described later if a practical view is obtained of what is happening on the inside rather than to try to understand the results of laws or equations. Later, these fundamental principles will be referred to a great many times to get an insight of the actual workings of the different electrical machines, therefore it will pay the reader to get them firmly fixed in his mind.

Electricity is only one of several peculiar happenings in nature which are very common to us, but which are more or less mysterious. Sound, heat and light are in many respects similar in action to electricity, and on account of their being more easily understood it will be advantageous to compare a few of their actions. In each case there is a generating, a transmitting and a receiving apparatus. In each the product is invisible as it travels along the transmission system; consequently, what has happened must be judged from the effects produced.

Sound Analogy.—If a pencil is tapped on the desk, the contact generates a sound. This sound is transmitted in

every direction along many paths from the point of contact. One path is through the air to the ear. The air is the transmission and the ear is the receiving apparatus. If an easier path having less resistance to the sound as it travels along is substituted, the listener will get more sound at the other end. For instance, if the ear is held to a railroad track and someone hits the rail a blow a half-mile away, the sound can be heard through the rail. It could not be heard through the air. The rail is the better conductor. It will also be noted that the sound cannot be seen as it travels along the rail or through the air. If the pencil is tapped on the desk with a greater speed, more sound will be transmitted to the ear than if tapped with a slow motion. There are two ways, therefore, of getting more sound—improving the conductor by using one of less resistance, and increasing the speed of the generator. This is similar to the conditions in an electrical generating system.

Heat Analogy.—If one end of an iron rod is held against an emery wheel and the other in the hand, the emery cutting across the iron will generate heat, and the heat will flow along the rod to the hand. Thus we have a heat-generating system—a generating, a transmitting and a receiving apparatus. The emery wheel cutting across the iron is the generator, the rod is the transmission and the hand is the receiver. Here, too, the heat transmitted will depend upon the speed of cutting and the nature of the conductor. If a wooden rod is substituted, very much less heat will flow. If a vacuum is inserted in the line of transmission, practically no heat would flow across it; that is, it is an insulator to the flow of heat. It will be noticed in heat transmission also that nothing can be seen moving along the line of flow. Its effects must be dealt with, and it will be found that electricity is a close relative of heat and similar to it in some respects.

Light Analogy.—Light also has many characteristics that are similar to electricity. When the filament of an incandescent lamp is heated to a certain temperature, it begins to

send out light. The light is transmitted along a line to the eye. It travels at a very rapid rate, much faster than heat or sound. Electricity travels at even a faster speed than light. As light travels along lines in space, it is also invisible to the eye. It is only when the end of one of these lines reaches the eye, either direct or reflected, that the light is detected by the eye. This is clearly shown by the moon. At night the space around the moon is full of light rays, or lines of light from the sun, but it is only those lines that strike the moon and are reflected to the eye that give the sensation of light. The other lines of transmission of light are invisible and the passage of light along them cannot be seen.

Electricity Similar to Heat, Sound and Light.—Electricity is in several ways similar to these phenomena of heat, sound and light. It is invisible and for that reason we must use our imagination and be governed by its effects. It is not known exactly what it is, but that need not confuse the student, because there are other very common things in the same class. When the rod was held on the emery wheel, heat passed along the rod to the hand. We do not know exactly what it is that moves along the rod, but we know its effects. Light passing from the lamp must send something along the line to the eye. It is said to be wave motion and that no material substance actually passes. To make this clearer suppose a wire on a pole line is struck with a pair of pliers. This will cause a wave to travel along the wire to the next pole. It was the wave that went to the next pole and gave it a sensation, no material substance actually passed along the wire. That is the way light travels through space, but at a speed a million times faster. There is some sort of a vibration at the generator of light—a wave is sent along a line in space and finally reaches the eye and gives it a sensation similar to that which the pole received. Electricity is a similar action of the internal substance of the wire. Nothing actually passes, but as with light, heat and sound, we say it flows along the wire, which is the transmitting medium.

Electricity must, therefore, be studied from its effects,

or rather, the effects of electricity must be studied, because they are, after all, what we deal with in all electrical machinery. As in the case of heat generating, take a simple example of an electrical generating system and study the effect in each unit apart. By understanding the fundamental actions that occur in each part, the more complicated electrical machinery, which is simply an enlargement of these actions, will be simplified.

Electrical Generating System.—If a magnet is used in place of an emery wheel and a copper wire in place of the rod, we have an electrical generating system, as shown in Fig. 1. A magnet (for our purpose) is a piece of steel that

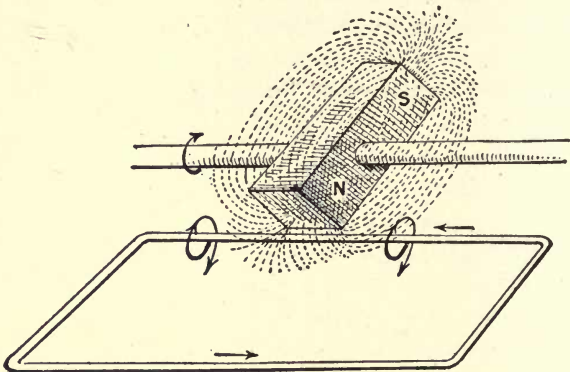

FIG. 1.—Illustrates fundamental principle of electric generator.

gives out magnetic lines of force. If this magnet is rotated so that the end passes across the copper wire, not quite touching it, and the magnetic lines coming out of the end of the magnet are cut across by the wire, electricity will be generated in the loop. The emery, by actual contact with the rod when cutting across it, generates heat in the rod. The magnetic lines, by actual contact with the copper wire when cutting across the latter, generate electricity in the conductor. In the first case it is said to be the friction of the particles of emery on the rod that generates the heat. In the second case it may be said that the friction of the

magnetic lines cutting across the wire produces electricity. We do not use the word friction, however, because that is used in connection with heat generation. We say in electricity generation it is the induction of the magnetic lines cutting across the wire, but it means practically the same thing.

This, therefore, is the all-important principle to remember—magnetic lines cutting across a closed wire loop generate electricity. This action is made use of in generators, transformers, motors and in fact, all commercial apparatus except heating or chemical appliances. The magnetic lines are made to cut across wires by several methods, but fundamentally it should be remembered that the cutting action of the magnetic lines across the wire generates the electricity.

How Electric Pressure Is Varied in a Wire.—The reader has probably noticed one thing in the figure for electricity generation that is different from that of heat generation—a return path is shown from the receiving apparatus. This is necessary in electricity or the current will not flow. The cutting of the magnetic lines across the wire generates an electrical pressure tending to send the current along the wire, but no current will flow until the complete path is made. This electrical pressure is called voltage. If the magnetic lines cut across the wire at a very slow rate, there is not as much friction or induction, and the pressure, or voltage, is low. If the speed of cutting the magnetic lines is increased, the pressure or voltage is higher. The pressure is directly proportional to the speed of cutting.

If the number of the magnetic lines is decreased there will not be as much friction, or induction as it is called, hence, the pressure or voltage will be less; also, if the number of lines cut is increased, it will proportionally increase the voltage.

It may therefore be seen how a pressure, or voltage, is generated in the wire, which tends to send an electric current along the wire. The amount of current that will flow

due to this pressure depends upon the resistance in its path. The amount of sound that came from the blow on the rail depended upon the resistance to the flow of the sound. Very little came through the air; most of it came through the rail. The rail had less resistance to the sound. The electric current will follow the path of least resistance in its endeavor to return to the generating point, and the amount of current, called amperes, that flows around this path will be governed by the resistance of the path for a given voltage. If the voltage is raised by speeding up the cutting or by increasing the number of lines, there will be more amperes flowing for a given resistance in the path. Therefore, the current depends upon two things—the resistance of the path and the pressure, or voltage, behind it. The voltage depends upon two things also—the speed of cutting the magnetic lines and the number of magnetic lines cut.

What Happens When Current Flows Through a Wire.—

The current is now flowing along the wire. Let us consider the things that are happening in and around the wire while the current is flowing through it. It has already been said that electricity is closely related to heat. It is a peculiar fact that electricity flowing along a wire produces heat. The amount of heat produced will depend upon the amount of current flowing and the amount of resistance offered. If practically all the resistance is in one place, that part will get the hottest. Copper wire is used to conduct the current because it offers very little resistance to the flow. When it is desired to produce heat, as in a flat iron, a section of conductor is placed in the path which offers a high resistance.

A close relative of heat is light. The wire in the electric bulb, if heated by forcing an electric current through it, quickly becomes hot enough to send out light. Light waves go out from the wire, due to the heat, and the heat is due to the electric current passing through a high resistance.

Besides the heating effect, there is the chemical effect of an electric current, but on account of its very small use in commercial machinery, it will not be taken up at this time.

Magnetic Effect of an Electric Current.—There is one other effect of the electric current—the magnetic effect. This is the effect from which all mechanical power from electricity is secured. As the current passes along the wire from the generator it sends out circular lines of magnetism around it. Electricity and magnetism are as closely related as heat and light. There may be heat without light and magnetism without electricity, but not light without heat, and similarly electric current cannot be had without magnetic lines. Whenever current is flowing in a wire, there are magnetic lines surrounding the conductor, and it is often for the sole purpose of getting these magnetic lines that an electric current is used. Except for heating, the magnetic lines surrounding the wire are what we are after in all electrical machinery.

When the path, or circuit, is completed in the simple generating system, the current flows and the magnetic lines spread out around the wire. When the circuit is opened, they close in and vanish. This will, perhaps, be made clearer by watching the hairspring of a watch. Let the shaft of the balance wheel represent the wire and the hairspring the magnetic lines that surround it. Let the tick of the escapement represent the opening and closing of the circuit. On one tick the circuit is closed, the current flows and the magnetic lines spread out around the wire. Another tick, the circuit is broken, the current stops and the magnetic lines close in. If the current is left on and is continuous in the same direction, the magnetic lines will spread out to a certain value and remain stationary as long as the current remains the same. Magnetic lines cannot be produced with pressure or voltage alone on the wire; the circuit must be closed and current flowing.

Magnetic Field Varies with the Current.—The number of lines surrounding the wire will depend upon the amount of current, or amperes, flowing. If the current in the wire is reduced, the surrounding magnetic lines close in, and if the current is reduced to zero, they do not immediately vanish.

but close to zero gradually. If the current is increased, the magnetic lines spread out and more take the place of those spreading out. This spreading out and closing in of the magnetic lines is extremely important, because the motion of these lines is made use of in cutting across near-by wires. This action will be referred to a good many times in later chapters.

Nothing has been said as yet regarding the direction of current in the wire. This is important, because it governs the direction of the magnetic lines about the wire. Returning to the simple generating system, Fig. 1, it will be seen that the ends of the permanent magnet are marked N (north) and S (south) pole. The magnetic lines are supposed to come out from the north pole of the magnet and return to the steel through the south pole. There will be a different effect produced in the wire when it cuts through the lines of force from the north pole than when through those from the south pole. One will induce a pressure tending to send the current around the loop in one direction, and the other will tend to send the current around in the opposite direction. That is, the direction of the current in the wire will alternate every time the magnetic lines from a different kind of a pole cut the wire. In other words, an alternating current is produced. Also, if the direction of the cutting is changed from upward to downward with the same pole, the direction of the induced current will be changed.

Causes Changing Direction of Current.—It is very important to remember that the direction of the current induced in the wire will alternate from two causes—one due to changing the direction of the magnetic lines and the other due to changing the direction of the wire across the lines of force.

There is no change in the heating effect due to the change in direction of the current. It is the same no matter in which direction the current flows. There is a change, however, in the magnetic effect. As the current starts in one direction, the surrounding magnetic lines start around the

wire in a given direction and spread out as the current increases to its maximum value; then, as the current decreases to start in the other direction, the magnetic lines close in until the current becomes zero. When the current reverses, the magnetic lines go around the wire in the opposite direction and spread out as the current increases. To remember this change in direction, imagine a screw going into a hole. As the screw goes in the direction of the current, the threads will go around in the direction of the magnetic lines. As the screw is withdrawn with the current coming toward the observer, the threads will go around in opposite direction. This action is continually changing as the current goes in one direction, then in another. As the current changes direction, it does not chop off suddenly and go in the opposite direction. It decreases gradually to zero, changes direction, increases gradually to its maximum value then decreases to zero again. This increasing and decreasing of the current is accompanied by an increasing and decreasing of the surrounding magnetic lines.

CHAPTER II

ELEMENTARY MAGNETISM

Discovery of the Property of Magnets.—Before a clear conception can be obtained of electrical machinery, one must first understand the principles of magnetism. Magnets in some form or other enter into all machines for the generation and utilization of electricity. Consequently, at the beginning of this electrical study course it is essential that we direct our attention to this subject.

The discovery of the property of magnets is something that has come down to us from the ancients; the exact dates are not known. Magnets were first found in a natural state; certain iron oxides were discovered in various parts of the world, notably in Magnesia in Asia Minor, that had the property of attracting small pieces of iron. Fig. 2 shows one of these magnets; as will be seen, it looks very much like a piece of broken stone. Fig. 3 is the same magnet after it has been placed in a box of small nails and withdrawn.

The property which the natural magnet possesses of attracting small pieces of iron or steel is called magnetism, and any body possessing this property is called a magnet. Outside of iron and steel there are very few substances that a magnet will attract; nickel and cobalt are the best, but the magnetic properties of these metals are very inferior when compared with those of iron and steel.

Artificial Magnets.—When a piece of iron or steel is brought under the influence of a natural magnet, it takes on the same property; that is, it also becomes a magnet and is said to have been magnetized. The greatest effect is obtained by bringing the iron or steel in contact with the magnet. One of the remarkable features of this is that the



FIG. 2.—Natural Magnet.

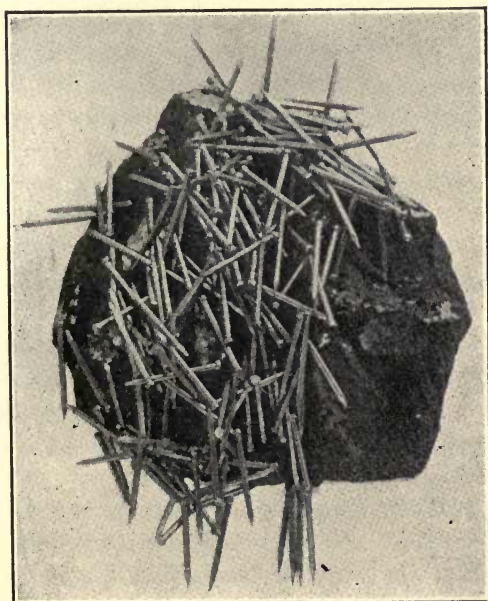

FIG. 3.—Natural magnet attracting iron nails.

magnet imparts its property to the piece of iron or steel without any apparent loss of its own. Why this is so will be discussed when we consider the theory of magnetism later in this chapter.

A magnet that is made by bringing a piece of steel or iron under the influence of another magnet is called an artificial magnet. Artificial magnets may be divided into two classes—temporary and permanent magnets. A piece of iron brought under the influence of a magnet becomes magnetized, but when it is removed from this influence, it loses the property of a magnet almost entirely, therefore, is called a temporary magnet. That is, it remains magnetized only as long as it is under the influence of another magnet.

Permanent Magnets.—On the other hand, if a piece of hard steel is rubbed on a natural magnet, it will become magnetized, and when removed from this influence, it will retain its magnetic properties. Hence we have a permanent magnet. Permanent magnets are usually made in two forms; namely, bar magnets and horseshoe magnets. When made in straight bars, as in Fig. 4, they are called bar magnets, and when in U-shape, as in Fig. 5, horseshoe magnets.

The natural magnet, when suspended from the end of a thread, possesses the property of pointing north and south the same as the needle of a compass. This discovery was used to advantage by the ancients to direct the course of their ships at sea. Hence the natural magnet got the name lodestone (meaning leading stone).

Properties of Magnets.—If a bar magnet is suspended from a string, as in Fig. 6, it will take a position almost directly north and south. The end that points toward the north pole of the earth is called the north or N pole of the magnet. The end pointing to the south pole of the earth is called the south or S pole of the magnet, as indicated in the figure.

If a magnet is suspended as in Fig. 7 and the N pole of a second magnet brought near the N pole of the one that is suspended, it will be found that they will repel each other;

that is, the suspended magnet will move away from the one that is brought near it, as indicated by the arrow-head. On the other hand, if the S pole of the second magnet is brought

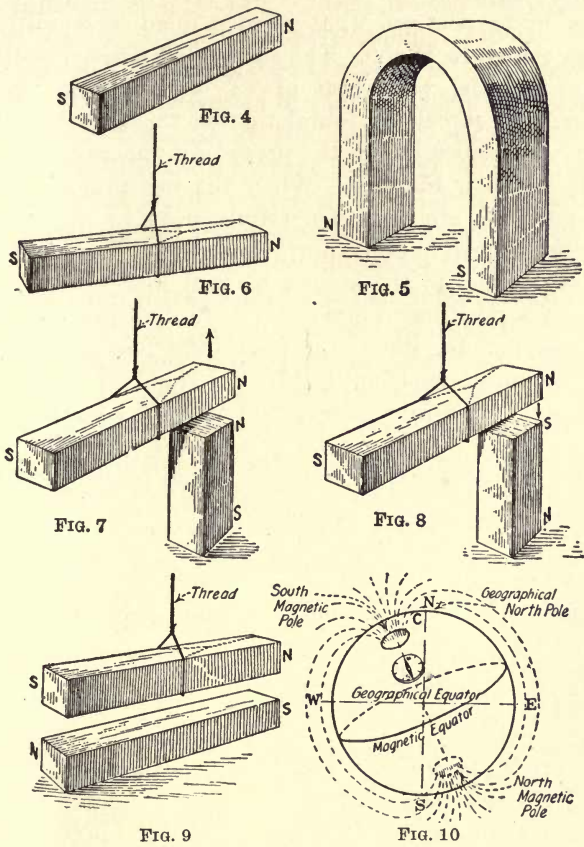

FIGS. 4 to 10.—Illustrate some of the properties of magnets

near the N pole of the suspended magnet, as in Fig. 8, it will be found that they will attract each other and the end of the suspended magnet will be drawn to the one held in the hand. The same effect will also be found at the S pole of the suspended magnet; namely, between like poles there is repul-

sion, and between unlike poles there is attraction. From this we may write the first law of magnetism, which is: *Like poles repel and unlike poles attract.*

Carrying this one step farther and holding the second magnet under the one that is suspended, a condition will exist as shown in Fig. 9. The suspended magnet will take a position parallel with that of the one held in the hand. Furthermore, it will be found that in this case unlike poles attract, as pointed out in the preceding paragraph.

The Earth a Magnet.—When the bar magnet was suspended from a string and not influenced by anything else, it pointed approximately north and south, just as it took a position parallel to the second magnet in Fig 9. Therefore we are in a position to make the deduction that the earth is also a magnet, for it has the same influence upon a magnet as the second magnet had in Fig. 9. This is true. The earth is a magnet, and any effects that may be obtained from a magnet may be obtained from the earth's magnetism.

In Figs. 6 to 9, it was pointed out that unlike poles attract and like poles repel. It was also shown that the end of the magnet that pointed to the north pole of the earth is called the N pole. Consequently, if unlike poles attract, the magnetic pole of the earth must be opposite to that of the magnet; that is, the earth's magnetic pole located near the geographical north pole is a south magnetic pole and that located near the south geographical pole of the earth, a north magnetic pole. The true condition is shown in Fig. 10, which represents the earth and its poles. The position that a compass needle will take is indicated in the figure. It will be seen that the compass does not point due north and south. In order that ships may be steered by a compass, magnetic charts must be used showing the correction that must be made for the declination of the compass needle.

Poles of a Magnet.—The ends of a magnet are called its poles and the distance midway between the poles the equator, as shown in Fig. 11. It is at the poles that the magnet possesses the greatest attraction for pieces of iron, and this

attraction decreases until the center, or equator, of the magnet is reached, where it becomes zero. This attraction is represented in Fig. 12, where a magnet is shown attracting three pieces of iron at its poles. At a distance in from the pole it will attract only two, a little nearer the equator it will hold but one, and at the equator none. The same effect may be obtained if the magnet is placed in iron filings and then withdrawn, as indicated in Fig. 13. Here it is seen that the filings are bunched at the ends of the magnet, but decrease toward the center where it is clean.

The space outside of a magnet is occupied by a field of influence and is called the field of the magnet or a magnetic field. This field of influence emanates from the N pole and circulates around through space and enters at the S pole, as indicated in Fig. 14. It will be noticed that the greatest number of lines emanate from and enter at the poles, although some of them leave and enter at the sides of the magnet. That some of the magnetism exists along the sides of the magnet would be expected from the results seen in Figs. 12 and 13: there must be magnetism around the sides of the magnet or it would not have attracted the pieces of iron; but, as pointed out before, it becomes less as we approach the equator, where it is zero.

Distribution of Magnetic Field.—There are many ways of determining the distribution of the magnetism about a magnet. One of the simplest is to place the magnet under a piece of glass and then sprinkle iron filings upon the latter. By gently rapping the glass, the filings will take definite paths, as indicated in Fig. 15. It will be seen that, although the lines are broken, they nevertheless conform very closely to those shown in Fig. 14. After the filings have been arranged so as to show the direction of the magnetic field, if the glass is placed over a sensitized paper, a photograph may be made of the formation. The field of influence from the poles of a magnet is known by various names, such as magnetic field, magnetic flux, flux from the magnet or field poles, and lines of force, but they all mean one and the same thing.

Another method of determining the direction of a magnetic field is illustrated in Fig. 16. A magnetized needle is pushed through a bottle cork and floated in a vertical position in a vessel containing water. If the dish is placed over a bar magnet with the S pole of the needle over the S pole of the magnet

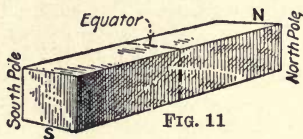

FIG. 11

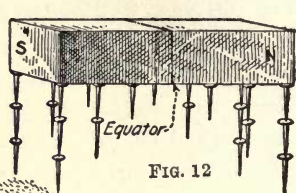

FIG. 12

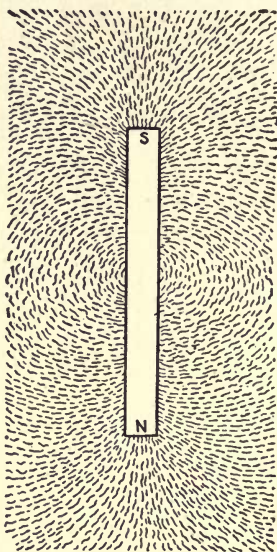

FIG. 15

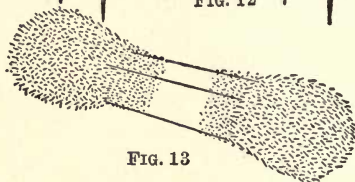

FIG. 13

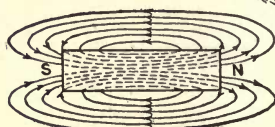

FIG. 14

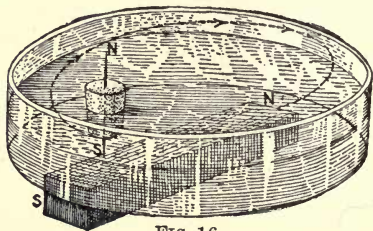

FIG. 16

FIGS. 11 to 16.—Show the distribution and direction of a magnetic field.

of the magnet, it will be found that instead of the cork with the needle floating along the axis of the magnet to the N pole, it will take a curved path like that indicated in the figure. This is similar to the path shown by the iron filings in Fig. 15.

Lines of Force Conventional.—The strength of a magnetic field is expressed as so many lines of force per square inch

or square centimeter. This naturally brings up the question of what constitutes a line of magnetic force or how these lines are counted or measured. In the first place, the term "line of force" is only figurative, because in the true sense, or at least as far as we know, such a thing as a definite line does not exist. Therefore, the lines which are generally shown in pictures of magnets are used only to indicate that there is a flow of "something" from the N to the S pole of the magnet and the direction of the flow.

If we were to place two fans so that when they were running one would be blowing against the other, the force of the air would tend to cause them to separate. If they were suspended from long cords and a spring balance connected between them, the force that one exerted on the other could be measured.

Suppose, for example, that the fans tend to separate with a force of 10 oz. If, instead of calling this force ounces or pounds, we called each ounce of repelling force a line of air, it would be the same thing that is done in measuring the strength of a magnetic field; only in the magnetic measurements a unit called a dyne is used. This unit is known as the centimeter-gram-second (c.g.s.) unit and is equivalent to $\frac{1}{445,000}$ part of a pound.

Unit Magnetic Pole.—If the like poles of two magnets are placed one centimeter (approximately $\frac{1}{4}$ in.) apart, as shown in Fig. 17, and they repel each other with a force of one

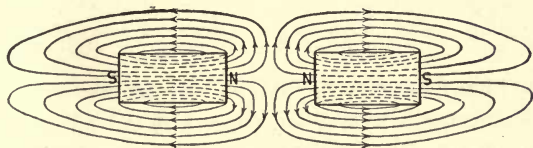

FIG. 17.—Shows how like poles of magnets repel.

dyne, the magnetic field is said to be of unit strength. Therefore one line of magnetic force is just what the term would imply; namely, a force, just as one fan blowing

against the other created a force which tended to separate them.

To express the magnetic unit more accurately, when two magnets of equal strength, of one sq.cm. cross-section each, are placed one centimeter apart in air and repel each other with a force of one dyne, they are said to be of unit strength. In this case the field of the magnet is said to be of unit intensity—that is, one line of force per square centimeter—and is called a gauss, after Karl Frederick Gauss, a German scientist. So we see there is nothing mysterious about this unit; it is a unit of measurement just as the pound or ounce.

How Magnets Attract Pieces of Iron.—In a foregoing paragraph in this chapter we found out that a magnet would attract a piece of iron or steel, but had little or no attraction for other substances. This naturally brings up the question, “Why is this so?” Anything that a magnet can magnetize it will attract. When we say that a magnet will attract a piece of iron, it is not a true statement. What really happens is that the piece of iron is first made a magnet and then the magnetism in one attracts the magnetism in the other. In Fig. 18 is shown a bar magnet M . If a piece of iron F is

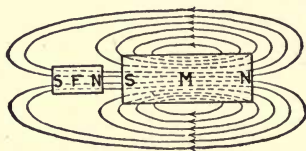

FIG. 18.—Shows how a magnet attracts a piece of iron.

placed as shown, it will become a magnet having N and S poles, as indicated. It will be seen that the end of the iron nearest the S pole of the magnet has become an N pole and that some of the lines of force from magnet M are passing through the piece of iron. We have previously found out that unlike poles attract, therefore if the end of the iron next to the south pole of the magnet is made a north pole, it will

be attracted by the S pole of the magnet. This is why a magnet will not attract other substances—because it cannot first make magnets out of them.

Why Iron Can Be Magnetized.—The foregoing brings up another important question, “Why can a piece of iron be magnetized and most other substances not?” The answer to this is found in the theory of magnetism. If a bar magnet is broken into several pieces, as shown in Fig. 19, each piece

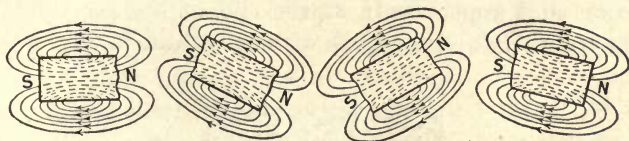

FIG. 19.—Results of breaking bar magnet in a number of parts.

will be found to be a magnet with a north and a south pole, as shown. This experiment can be easily made by magnetizing a hack-saw blade and then breaking it into several pieces. Each piece will be found to be a magnet. If the parts are placed together again it will be found that the magnetic poles of each piece will disappear at the division and be present at the two ends, as shown in Fig. 20. There

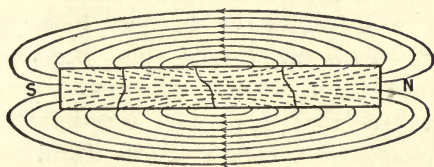

FIG. 20.—Results of placing together parts of magnet, Fig. 19.

is one conclusion to draw from this fact, and that is, if the magnet is broken up into infinitely small pieces, each piece will be a magnet with a north and a south pole.

Theory of Magnetism.—There are many theories of magnetism, but the one given preference to-day is based on the foregoing hypothesis. It must be remembered that just what magnetism is, is a scientific question that is not settled. What is generally accepted is that each molecule of iron is

a magnet in itself. Under natural conditions the molecules take a position so that the poles of one neutralize those of the other, as shown in Fig. 21, just as the poles of the pieces of magnet in Fig. 20 neutralize each other when they were brought together. When the pole of a magnet is brought near a piece of iron, it will attract the opposite pole of the molecules and pull them around in a systematic form, as in Fig. 22, and the lines of force of one molecule will pass into the other and appear only at the end of the piece of iron, just as the poles of the pieces of magnet did in Fig. 20.



FIG. 21



FIG. 22

FIGS. 21 and 22.—Illustrate Weber's theory of magnetism.

Of the many theories of magnetism, the one just given perhaps best accounts for the different magnetic phenomena and was first advanced by Wilhelm Eduard Weber, a German scientist. It accounts for the fact that a piece of soft iron will remain magnetized only while under the influence of another magnet and a piece of hard steel will remain permanently magnetized when once magnetized. The iron being soft compared with hard steel, the friction between its molecules will be less; therefore, when a piece of iron is put under the influence of a magnet, its molecules will be easily arranged systematically, or in other words, easily magnetized. When taken away from the influence of the magnet, the molecules can easily arrange themselves so that they will neutralize each other and the iron will become demagnetized. With hard steel, however, the friction between the molecules is high, and it is much harder to magnetize than a piece of soft iron. But the friction that causes the steel to be difficult to magnetize will tend to hold the molecules in a systematic

arrangement after they have once taken such a position, and the steel remains magnetized, or in other words, a permanent magnet is obtained.

How Magnets Are Demagnetized.—After steel is once magnetized, it will remain so indefinitely unless subject to some outside influence such as that of another magnet or vibration. If a permanent magnet is hit a few times with a hammer, it will be found to have lost its magnetism. This is caused by the molecules vibrating when the piece of steel was hit. The effect is similar to that of placing grains of sand on a plane that is slightly inclined. As long as the plane remains motionless, the sand will not move down its surface, the friction between the plane and the sand being sufficient to prevent the latter from moving. If the plane is struck with a hammer and caused to vibrate, the sand is loosened up from the surface, or in other words the friction is decreased, and it gradually works down the plane. Similarly, in the permanent magnet when it is hit with a hammer the molecules are caused to vibrate, which decreases the friction between them, and they gradually pull each other around to a position where their poles neutralize. The same effect is obtained by heating the magnet. This is due to two reasons: First, the steel loses its hardness, and secondly, heating causes the molecules to vibrate as when the magnet is struck with a hammer.

In the foregoing it was pointed out that a magnet imparted its properties to a piece of iron without any apparent loss. From what we have found out about the theory of magnetism it is evident that a magnet does not really impart its property to a piece of iron, but rather makes manifest those properties already in the iron; therefore, the magnet is not subject to any action that would cause a loss.

Electricity and Magnetism.—As pointed out in Chapter I, there may be magnetism without electricity, but not electricity without magnetism, just as heat can be produced without light, but light cannot be produced without heat. What the relation of one is to the other is a scientific ques-

tion that is not settled. But that has nothing to do with our study; suffice it to keep the fact in mind that when an electric current flows through a wire, it sets up a magnetic field about it. This is a very important feature in the whole study of electricity and magnetism.

Direction of Magnetic Field About a Conductor.—The directions of the lines of force about a conductor with a current of electricity flowing through it will depend upon the direction of the current. The direction of the current and the corresponding direction of the magnetic flux about a conductor is indicated in Figs. 23 and 24. In these figures



FIG. 23



FIG. 24

FIGS. 23 and 24.—Show direction of field about an electric conductor.

the full-line circle represents the cross-section of the conductor, the dotted circle and arrow-heads the magnetism and its direction, and the cross and dot in the center of the circles the direction of the current. It is important that the two latter conventionals be firmly fixed in the mind, since they are frequently used to represent the direction of current flowing in a conductor. In Fig. 23 the cross represents current flowing away from the reader. It will be seen that the lines of force are whirling in a clockwise direction. The dot in the center of the circle, Fig. 24, indicates current flowing up through the plane of the paper. This is just opposite to that in Fig. 23, and as will be observed, the direction of the magnetic field about the conductor has reversed, or is now in a counter-clockwise direction.

Relation Between Direction of Current and Magnetic Field.—These things are so simple that it is hard to remember just what each represents; therefore a rule will not be out of place. Referring to the direction of the current in the

conductor, the cross and dot in the center of the circle may be considered to represent an arrow moving in the direction of the current, the cross representing the tail of the arrow and the dot the point. Consequently, if we wish to know which direction of current the cross represents, we may reason like this: The cross represents the tail of the arrow, therefore the arrow must be pointing away from the observer for this part to be seen. Hence, the cross represents current flowing away from the reader. Likewise for the dot; it represents the point of the arrow. The arrow must be pointing toward the observer for the point to be seen, consequently, the direction of the current which it represents.

The next thing to remember is the direction of the lines of force about the conductor. A simple rule for this is to grasp the conductor in the right hand with the thumb pointing in the direction of the current, as indicated in Fig. 25;

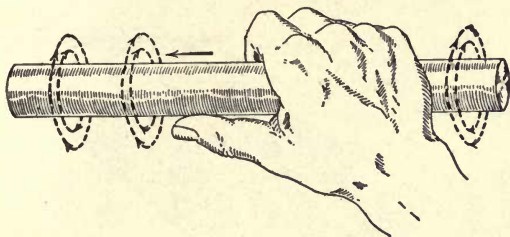

Fig. 25.—Right-hand rule for telling direction of field about an electric conductor.

the fingers will then point around the conductor in the direction of the lines of force.

The field about a wire carrying an electric current does not take the form of a spiral, but a circle, as shown in the figures. These circles seem to emanate from the center of the conductor and have an increasing diameter as the current increases. This is illustrated in Fig. 26, *a*, *b*, *c*, and *d*. At *a* is represented the effect that would be obtained from a small current flowing in the conductor; at *b*, *c*, and *d*, the successive development of the magnetic field as the current flowing through the wire increases.

Determining Direction of Magnetic Field About a Conductor.—There are several ways of determining that a magnetic field is set up about a conductor carrying an electric current. If a wire is placed through a hole in a piece of glass

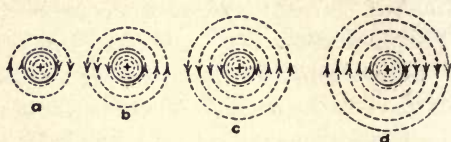

FIG. 26.—Illustrates how field builds up about a conductor as current increases.

or cardboard, as shown in Fig. 27, and an electric current is caused to flow through the wire, then if iron filings are sprinkled upon the glass or cardboard, they will be arranged in broken circles, as indicated in the figure. To get the best effect it will probably be necessary to tap the edge of the

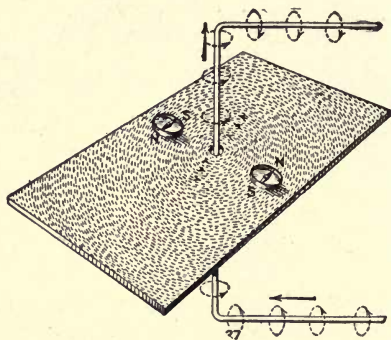

FIG. 27.—Showing magnetic field about a conductor with iron filings.

surface. Placing a compass in various positions as shown, it will always point in a definite direction around the conductor. It will be observed that the compass points in an opposite direction on opposite sides of the wire.

This fact may be used to determine the direction of an electric current in a conductor. In Fig. 28 is represented a wire carrying a current in the direction of the arrow; the magnetic field is shown by the dotted circles and arrow-

heads. If a compass is placed on top of the conductor, it will point in the direction of the magnetic field above the wire, likewise if placed underneath; namely, as indicated in the figure. After the direction of the magnetic field has been determined by the compass, if the wire is grasped in the

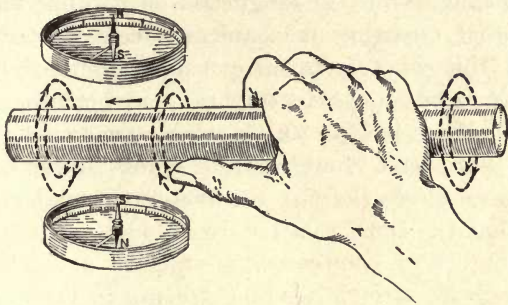
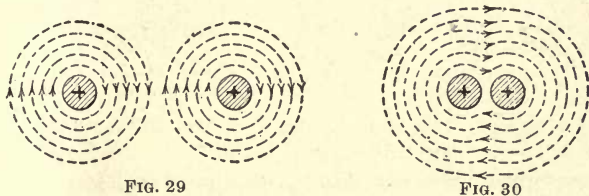

FIG. 28.—Shows direction of compass when placed near an electric conductor.

right hand with the fingers pointing around the conductor in the direction that the compass points, the thumb, when pointing along the conductor, will indicate the direction of the current, as illustrated in the figure.

Magnetic Field Around a Number of Conductors.—In Fig. 29 are represented two parallel conductors having an



FIGS. 29 and 30.—Direction of magnetic field about two conductors carrying current in the same direction.

electric current flowing in the same direction in each and supposed to be far enough apart so that the magnetic field of one will not have any influence on that of the other. The direction of the magnetic field between the two conductors

will be seen to be in an upward direction on one and downward on the other. If the two conductors are brought near together, the two fields between them will oppose each other and since the field strength of both is the same, no lines of force will pass between the wires, for be it remembered that equal opposing forces in magnetism neutralize each other just as equal opposing mechanical forces neutralize each other, but this does not destroy the magnetic field in this case. The result of bringing the two conductors close together is shown in Fig. 30. It will be seen that the whirls about one wire have combined with those of the other, and now the lines circle the two conductors instead of one and this field has the same relative direction as that in Fig. 29.

If a number of conductors are placed alongside of one another with an electric current flowing in the same direction in them, all their magnetic fields will combine and form a field that will encircle the group. This is the effect obtained in a coil of wire connected to a source of electricity. In Fig. 31 is shown the cross-section of a coil of four turns;

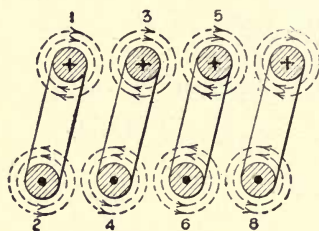

FIG. 31

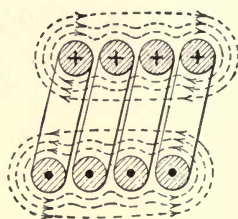

FIG. 32

FIGS. 31 and 32.—Show how the magnetic field is set up in a solenoid.

the direction of the current through the coil is indicated by the crosses and dots. That is, it flows in at 1 and out at 2, in at 3 and out at 4, etc. The turns are supposed to be separated far enough so that the flux of one will not affect that of the other. From an examination of the figures it will be seen that the direction of the lines of force on the inside of the coil all point in the same direction, likewise on the outside. Consequently if the turns are placed together as in

Fig. 32, the magnetic fields about the different conductors will coalesce into one and surround the whole group of conductors, as shown. That is, we would have a magnetic field emanating at one end of the coil and entering at the other, just as we did with the permanent and natural magnet. In the case of the coil, however, it is called a solenoid, but it has all the properties of a permanent magnet. It will attract pieces of iron, and if suspended by a string so that the axis of the magnetic field is in a horizontal position, it will point north and south just the same as a permanent magnet.

Properties of Electromagnets.—If the coil is supplied with a soft-iron core, as in Fig. 33, the combination is called

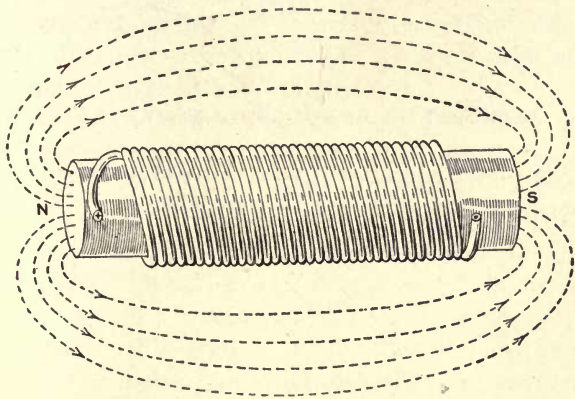

FIG. 33.—Field about an electromagnet.

an electromagnet. Although this device possesses the properties of a permanent magnet, it will remain magnetized only as long as current is flowing in the coil, and is therefore a temporary magnet.

A convenient rule for determining the polarity of an electromagnet when the direction of the current in the coil is known, is shown in Fig. 34. This is the rule for the direction of the flux about a conductor backward. If the coil is grasped in the right hand, as shown in the figure, with the

fingers pointing in the direction that the current is flowing in around the coil, the thumb will always point toward the

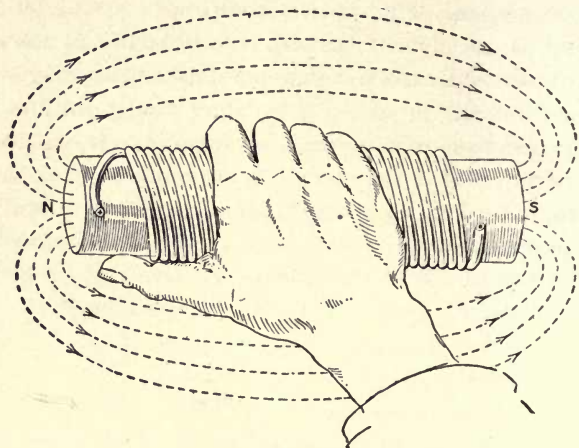

FIG. 34.—Right-hand rule for determining polarity of electromagnet.

north pole of the electromagnet. This is a convenient rule, often used, and an easy one to remember.

CHAPTER III

FUNDAMENTALS OF THE ELECTRIC CIRCUIT

Production of Voltage.—Electricity is an invisible agent that manifests itself in various ways, and as pointed out in the introductory chapter, it is in many ways similar to heat, light and sound. Although we do not understand the true nature of electricity, many of the laws that govern its production and application are thoroughly understood, and by the application of this knowledge very efficient electrical equipment is designed and constructed.

If a copper and a zinc plate are placed in dilute sulphuric acid, as shown in Fig. 35, a difference of electrical pressure will exist between them; that is, a current of electricity will tend to flow from the copper to the zinc plate. The terminal that the electric current tends to flow from is called the positive and is indicated by a plus sign (+); the terminal that the current tends to flow to is called the negative and is indicated by a minus sign (−). In other words, the positive terminal is at a higher potential than the negative. A device like that shown in the figure is called a voltaic cell or, as it is often referred to, a primary battery, of which there are a great many types.

One thing to be noted in the voltaic cell is that an electric current was not caused to flow; all that was created was a tendency for a current to flow from the positive to the negative terminal, or from the copper to the zinc plate. This electric pressure, or difference of potential, is expressed in a unit called a "volt," after Alessandro Volta, an Italian scientist, who discovered the voltaic cell. This cell is sometimes called a galvanic cell, after Volta's contemporary, Alvosio Galvani. If the terminals of the cell are connected

through a copper wire or other conducting material, as shown in Fig. 36, a current will flow as indicated by the arrows.

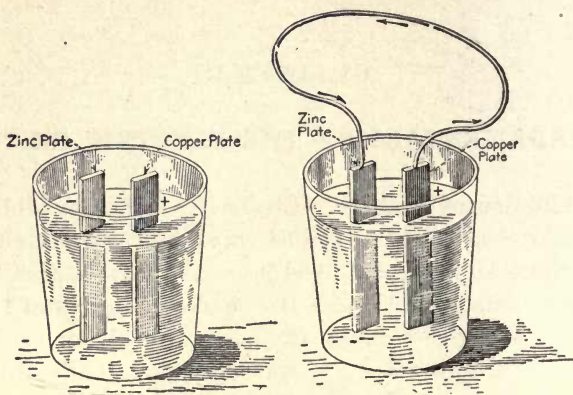

FIG. 35

FIG. 36

FIGS. 35 and 36.—Primary battery cells.

Electric Pressure and Temperature.—An analogy of this difference of electric pressure is found in heat. If we wish heat to flow from one body into another, a difference of

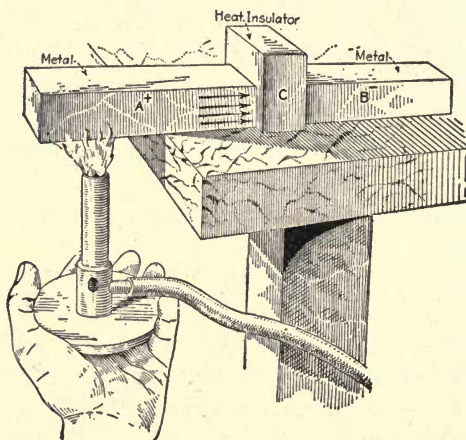

FIG. 37.—Temperature analogy of battery cell, Fig. 35.

temperature and also a path for the heat to flow must be provided. For example, consider the conditions in Fig. 37.

Here are two metal blocks, *A* and *B*, with a heat insulator *C* between them such as a firebrick or asbestos block. If heat is applied to the block *A*, as shown, its temperature will be increased above that of block *B*, or it might be said that a heat pressure exists between blocks *A* and *B*, just as an electric pressure existed between the copper and the zinc plates in Fig. 35; but on account of the insulation between the positive and negative terminals, which in this case is air, no current can flow. Likewise, in Fig. 37, a difference of temperature or heat pressure exists between *A* and *B*, which is expressed in deg. F. or deg. C. above or below a certain point, but no heat can flow into *B* because of the insulation between it and *A*.

If, now, we remove the insulating block and replace it by a metal block, as in Fig. 38, heat will be conducted from

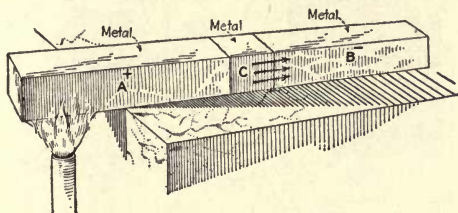

FIG. 38.—Temperature analogy of battery cell, Fig. 36.

A to *B*, just as an electric current flowed from the copper to the zinc plate in Fig. 36, when they were connected by a metal wire. It can hardly be said that one is any more mysterious than the other, and in fact we do not know any more about the true nature of one than the other. According to the electron theory of conduction in metals, the same thing takes place in both cases; that is, there is a flow of electrons from the point of high potential to that of the lower pressure. A discussion of this subject is outside the purpose of this study course; suffice it to note the close analogy between heat and electricity. Another thing is, materials that offer a high resistance to the flow of heat also offer a high resistance to the flow of electricity.

Unit of Electric Current.—The strength of an electric current is measured by the unit called an ampere, after a French scientist, André Marie Ampère. In the case of the heat flow from one body to the other, the quantity is measured in British thermal units (B.t.u.). When an electric current is passed through certain salt solutions, it will carry the metal from the terminal in the solution by which it enters and deposit it on the one by which it leaves. In Fig. 39 is shown a voltaic cell *C*, connected to two copper plates in a copper-sulphate solution *A*. The current in flowing from the plate marked plus, will carry some of the copper from this plate and deposit it on the negative plate; that is, the positive plate will become lighter, and the minus plate will

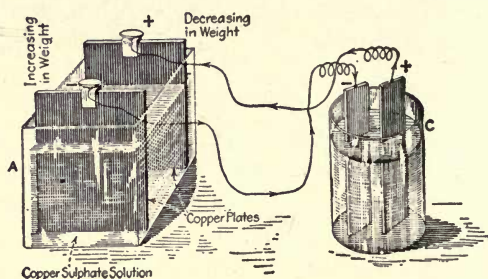

FIG. 39.—Battery cell connected to electro-plating tank.

increase in weight. This is what is done to determine the standard unit of current, only silver plates are used in a nitrate of silver solution. The electric current flowing is said to be of one ampere value when its strength is sufficient to deposit 0.001118 gram of silver per second on the negative plate. Therefore it will be seen that there is nothing more difficult about this unit of electric current than there is about the unit of heat (B.t.u.), which is the heat necessary to raise the temperature of one pound of water one degree F.—to be more accurate, from 39 to 40 deg.

Electrical Resistance.—All substances offer a certain amount of resistance to the flow of heat, or in other words, tend to prevent the heat from flowing from one part of a

body to another. For example, in Fig. 38, when the metal block was placed between blocks *A* and *B*, it was assumed that the heat would flow from *A* to *B* readily. In the case of Fig. 37, it was said that if a block of asbestos or firebrick was placed between the metal blocks, very little heat would flow from *A* to *B*, on account of the high heat-resisting properties of asbestos or firebrick. Similarly, all matter offers a certain amount of resistance to the flow of electricity; that is, tends to prevent its flow. Almost all good conductors of heat are good conductors of electricity. For example, copper is one of the best conductors of heat and also one of the best conductors of electricity. A very simple

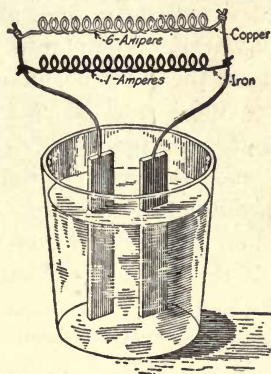

FIG. 40.—Battery cell connected to an iron and a copper circuit.

experiment can be made to test the heat-conducting properties of copper by taking equal lengths of copper and iron wire, using equal cross-sections in either case. No. 10 or No. 8 is a good size, and about 8 in. in length. Take one in each hand and hold each about the same distance in the flame of a Bunsen burner or blowtorch and observe which one of the ends you are holding gets hot first. It will be found that the copper will get uncomfortably hot before the iron begins to get warm, showing that the heat is conducted up the copper much faster than up the iron. The same thing is found in electricity; if equal lengths of the same size of copper and iron wire are connected to the same source of

electricity, as in Fig. 40, it will be found that about six times as much current will flow through the copper as through the iron, showing that copper is a much better electrical conductor than iron—it offers about $\frac{1}{6}$ the resistance.

No Perfect Insulators of Electricity.—On the other hand, firebrick, asbestos and other materials offer high resistance to the flow of heat. They also offer high resistance to the flow of electricity. Furthermore, there are no perfect insulators of heat, neither are there any perfect insulators of electricity.

The unit resistance offered by a substance to the flow of an electric current is called an ohm, after Dr. Georg Simon Ohm, a German physicist. The ohm is the equivalent of the resistance offered to the flow of an electric current by a column of mercury 106.3 cm. (41.85 in.) long by 1 sq.mm. (0.00155 sq.in.) in cross-section at 32 deg. F. This is approximately equal to the resistance of a round copper wire 1,000 ft. long by 0.1 in. diameter.

In Figs. 37 and 38 a flame was used to create a difference of temperature between the parts *A* and *B*. This difference of temperature could have been obtained by placing *A* in acid, although not to the same extent as by applying fire. Hence we have heat produced by acid attacking the metal, just as in the voltaic cell electric pressure was produced by the acid acting upon the zinc plate. Thus it is seen that a difference of heat pressure, or temperature, and a difference of electric pressure can be produced in the same way. Furthermore, an electric pressure can be produced by heat. When two dissimilar metals are joined together and the joint between them is heated, a difference of electric pressure will exist between them. Such a scheme is called a thermocouple and is illustrated in Fig. 41. When used in this way, antimony and bismuth produce the highest voltage. The electric pressure produced in this manner is very small, consequently the scheme has not come into very extensive use. Nevertheless, it shows the close relation between heat

and electricity. In the introductory chapter it was pointed out that heat was produced by the friction of one body rubbing on another, and that a difference of electric pressure was produced by a conductor moving through a magnetic field cutting the lines of force.

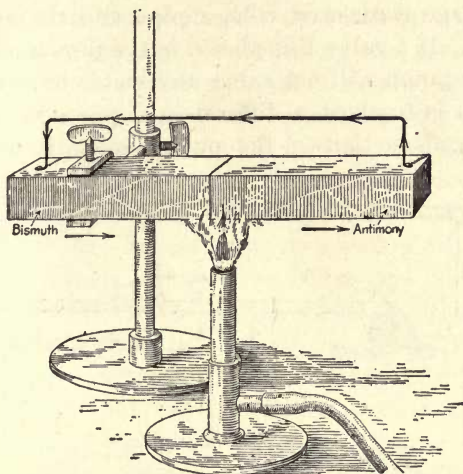

FIG. 41.—Bismuth and antimony thermocouple.

Pump Analogy of Electric Circuit.—In the foregoing we found out that by placing a copper and a zinc plate in dilute sulphuric acid, an electric pressure was created between them, and how, if the two plates were connected together by a wire, a current of electricity would flow from the copper to the zinc. We also compared the electric pressure with temperature, and if two bodies, one of a higher temperature than the other, are in contact with each other, heat will flow from the one at a higher temperature into the one at the lower temperature. This analogy serves a very useful purpose, for it shows that there are things that seem very simple which can be recognized only by their effects or manifestations, just as an electric pressure or current can be recognized only by its effects and manifestations.

Another analogy of electric pressure and the flow of an

electric current is found in a pump and the flow of water through a pipe. As this analogy lends itself most readily to illustrate many of the phenomena in an electric circuit, it will be the one most used in this and future chapters.

In Fig. 42 is shown a centrifugal pump with the suction and discharge connected with a pipe and the system filled with water. If a valve *V* is placed in the pipe line and closed, driving the pump will not cause any water to flow. All that it would do is to cause a difference of pressure between the discharge and suction of the pump, or, as it might be ex-

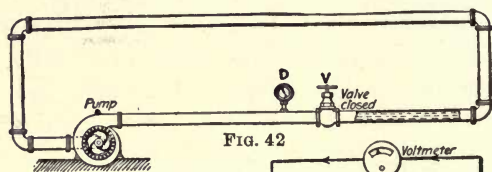

FIG. 42

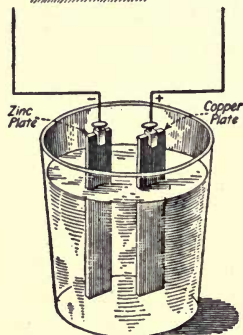

FIG. 43

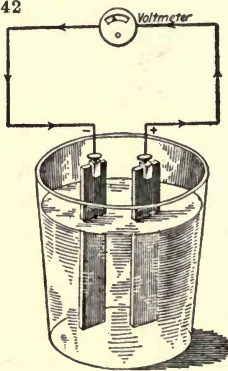

FIG. 44

FIGS. 42 to 44.—Compare electric pressure to pressure in a pump.

pressed, a tendency for the water to flow, just the same as a pressure is created between the copper and zinc plates in the voltaic cell, Fig. 43. As long as the plates are not connected externally, an electric current cannot flow.

Measurement of Pressure.—In heat, the temperature, or what might be called the “pressure,” is measured with an instrument called a “thermometer.” In the case of the pump the pressure is measured by a pressure gage, which

is shown at *D* in Fig. 42. The electric pressure of the voltaic cell, or any electric device, is measured by an instrument called a "voltmeter." This instrument is shown properly connected to measure the pressure between the positive and negative terminals of a voltaic cell in Fig. 44. The principle that the voltmeter operates on will be considered in a later chapter. To measure the pressure of an electric circuit the instruments must always be connected as shown in the figure; namely, one terminal of the instrument is connected to the positive and the other to the negative of the voltaic cell. This is true in all cases; it does not make any difference whether it is an electric generator or a power or lighting circuit. If we wish to measure the pressure between the terminals, connect the voltmeters as in Fig. 44.

Measurement of Current Flow.—If the positive and negative terminals of the voltaic cell are connected with a wire *W*, as in Fig. 45, a current of electricity will flow, just as a current of water would flow around in the pipe system if the valve *V* is open as in Fig. 47. To measure the flow of an electric current in a circuit, what may be called a "flow-meter" is used. This instrument is known as an ammeter (meaning ampere meter) and is shown properly connected in the circuit in Fig. 46. It will be seen that the ammeter is connected so that the current flowing through the circuit must also flow through the instrument, whereas the voltmeter is connected directly to the positive and negative terminals. If we wished to measure the water flow in the pipe line, a flowmeter would be connected in the system, as shown in Fig. 48. Comparing Fig. 46 with Fig. 48, it is at once apparent that the flowmeter is connected in the pipe line in a way similar to that in which the ammeter is connected in the electric circuit. In either case the flow is directly through the instrument.

How to Increase Voltage.—Since we have found out how to produce an electric pressure and current, the next thing is to know how to increase or decrease the quantity. The pressure of a voltaic cell is approximately two volts, irre-

spective of the size. Therefore, if it is desired to have a greater pressure than two volts, we will have to do something else besides change the size of the cell. A change in voltage is accomplished by connecting two or more cells in

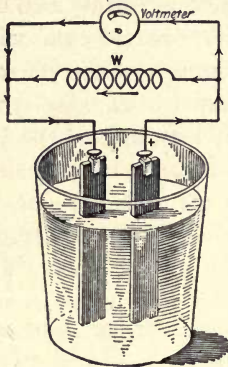

FIG. 45

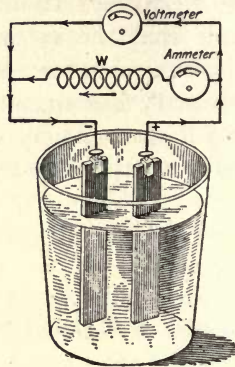

FIG. 46

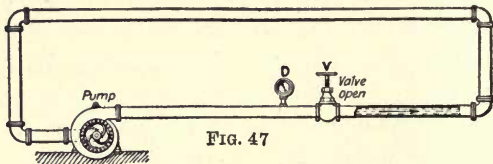

FIG. 47

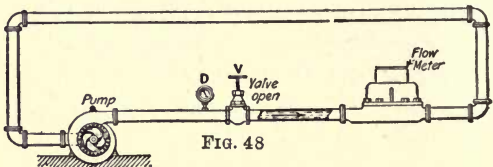

FIG. 48

FIGS. 45 to 48.—Compare flow of electric current with flow of water.

the proper relation to each other. For example, to obtain four volts, two cells of two volts each will have to be connected as in Fig. 49. This is known as a series connection. The positive terminal of cell *A* is connected to the negative terminal of cell *B* and the other positive and negative terminals brought out. The arrowheads indicate that the direction of the pressure in each cell is the same. It is very essential that the cells be connected as shown in the figure.

If they were connected as in Fig. 50, no pressure would be obtained between the outside terminals. This is evident when

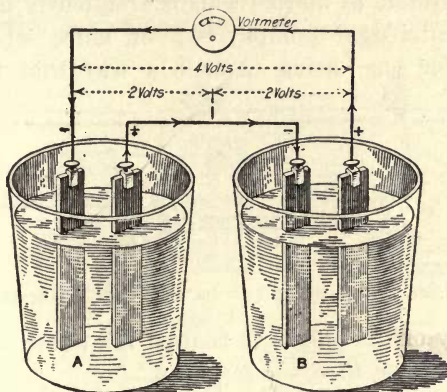

FIG. 49.—Two battery cells connected in series correctly.

it is considered that the pressure of one is opposing that of the other.

Pump Analogy of Voltage Sources in Series.—Coming back to our pump analogy, suppose the pump shown in Figs.

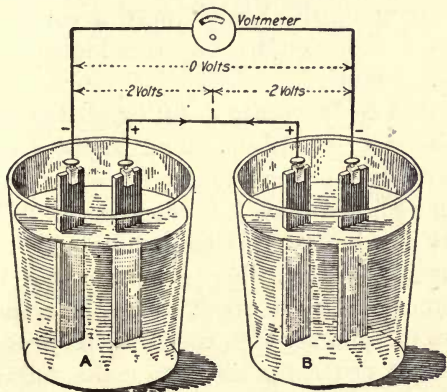

FIG. 50.—Two battery cells connected in series incorrectly.

42, 47 and 48 is only capable of producing 25 lb. pressure. To produce 50 lb. pressure, two pumps would have to be connected in series, as shown in Fig. 51. In this case pump

A would deliver the water to pump B at 25 lb., where B would again increase the pressure by 25 lb. and discharge it into the system at 50 lb. This is frequently done in high-pressure centrifugal pumps; two or more wheels are arranged under one casing in such a way that the pressure

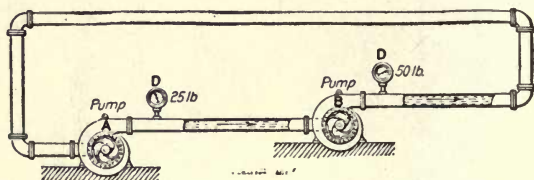

FIG. 51.—Pump analogy of two battery cells connected in series.

produced by one is added to that of the other and is known as a two-stage or three-stage pump.

To obtain more than four volts, more cells will have to be connected in series. For example, in Fig. 52, four cells are connected in series and the total pressure across them is 8 volts. Comparing Fig. 49 with Fig. 52, it will be seen that the latter is an enlargement of the principle involved in the former. A copper plate in one cell is connected to a zinc plate in the next, until there is only a copper and a zinc terminal remaining, and these two terminals are brought out to the external circuit.

How Current is Increased.—Although the pressure of a voltaic cell is not affected by its dimensions, nevertheless the dimensions are an important factor when the amount of current that can be taken from it is considered. The number of amperes that can be taken from a voltaic cell is almost in direct proportion to its cubic contents; that is, a cell of 10 cu.in. volume will have about twice the ampere capacity as one of 5 cu.in. volume, with the elements properly proportioned. It is not general practice to make voltaic cells very large in volume, therefore more than one cell must be used. To increase the current capacity and have the voltage remain the same, the cells are connected in parallel or multiple. Note that a parallel and a multiple connection are one and the same thing.

Two voltaic cells are shown connected in parallel, or multiple, in Fig. 53. It will be seen that the positive terminal of one cell has been connected to the positive of the other, likewise for the negative terminals. This is a very

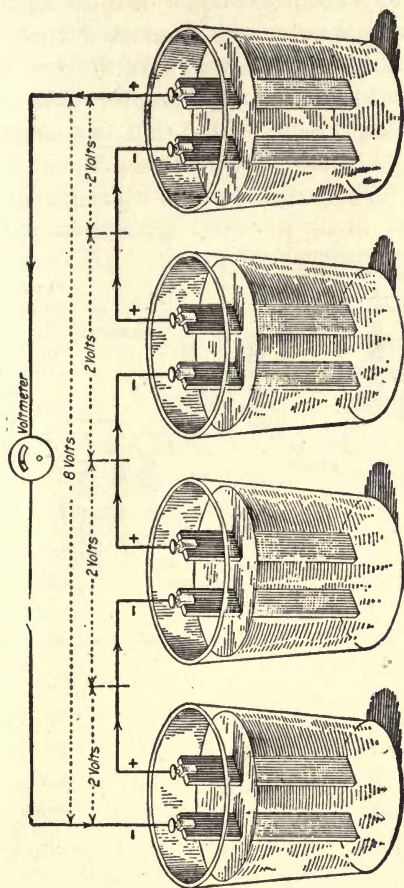

FIG. 52.—Four battery cells connected in series.

simple connection and easy to remember, and the rule for it may be written: *Connect like poles to like poles and bring out a positive and negative lead from the group.* A more common arrangement of a parallel connection is shown in Fig. 54. This is the same as in Fig. 53; that is, the positive

terminals are connected together, also the negative terminals, with a positive and negative lead brought out.

Pump Analogy of Current Sources in Parallel.—Connecting two voltaic cells in parallel is similar to connecting two pumps so that they both discharge into the same system, as in Fig. 55. The pumps are so connected that one may be shut down and only one operated. If the two are running, the pressure would not be any greater than when one is running, but it would be expected that two similar pumps of the same size would deliver twice as much water at the same pressure as one. The parallel connection is also similar to a

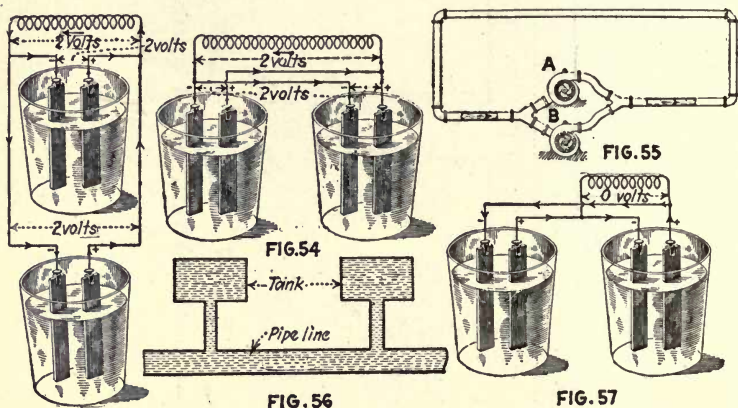

FIG. 53 FIGS. 53 to 57.—Illustrations of parallel connections.

pipe line that is being supplied from a storage tank. If one tank is used, a certain amount of water at a given pressure may be drawn off before the tank will have to be filled again. On the other hand, if two tanks are used, the same size, and connected into the pipe line, as in Fig. 56, twice as much water will be supplied to the pipe line, but the pressure will be the same as for one tank.

In connecting battery cells or electric generators in parallel it is essential that like terminals be connected together. If unlike terminals are connected, as in Fig. 57, it will cause a closed circuit between the cells and no current will flow through the external circuit. so A connection like

this would quickly destroy the cells on account of the heavy current that would circulate between them. This connection is similar to connecting two pumps, as in Fig. 58. In this case pump *A* will tend to cause the water to circulate around through the system in the direction of the arrow *a*, and pump *B* in the direction of arrow *b*. It is self-evident that opposite currents cannot flow around through the system. However, the water from *A* can discharge into *B*, and pump *B* into *A*, causing a circuit through the pumps, as indicated by the arrows *c*, similar to the electric circuit in Fig. 57.

If it is desired to connect more than two cells in parallel, the same general rule is followed as in Figs. 53 and 54; namely, connect like poles to like poles and bring out two

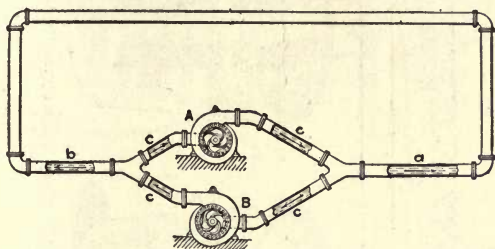

FIG. 58.—Pump analogy of incorrect parallel connection.

leads of opposite polarity. Fig. 59 shows four cells connected in parallel. Here the four positive terminals are connected together, also the four negative terminals, with a lead coming from the positive and another from the negative to the external circuit *L*. The arrowheads indicate the direction of the current which flows from the positive of each cell through the external circuit and back to the negative of each element, and if all cells are alike they would each deliver an equal amount of current to the circuit.

Series-Parallel and Parallel-Series Connections.—There are conditions that require not only a greater electric pressure than can be supplied by one cell, but also a greater current. We have already found out that connecting cells in series increases the voltage by the number connected.

Also by grouping cells in parallel, the current may be in-

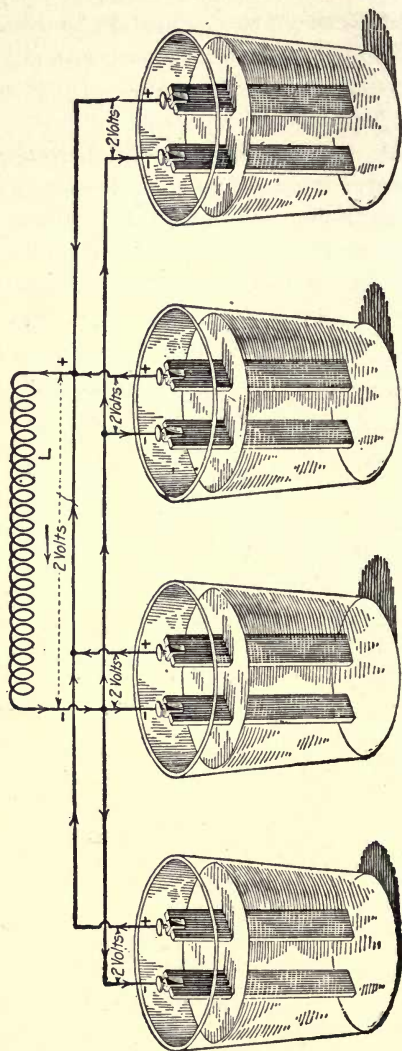

FIG. 59.—Four battery cells connected in parallel.

creased according to the number of cells so grouped. To increase the voltage of the group and at the same time make

it possible to increase the current, a number of cells can be connected in a combination of a series and a parallel grouping. There are two ways of doing this, first, series parallel, and second, parallel series. However, either connection produces the same result. In Fig. 60 are shown four cells con-

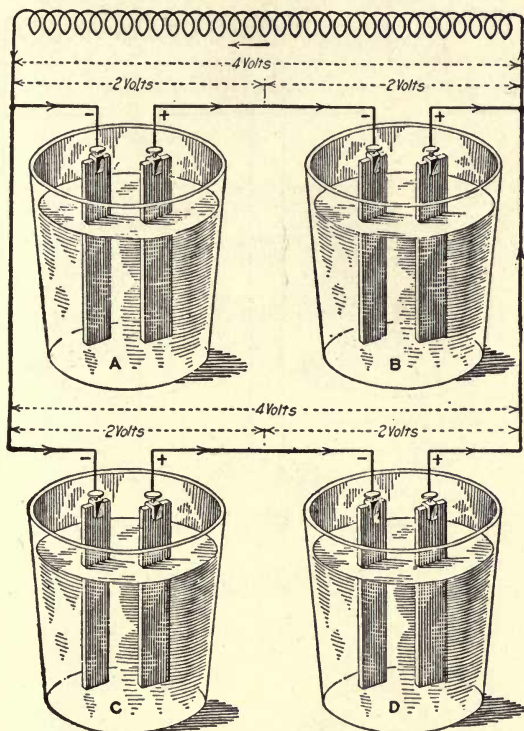

FIG. 60.—Four battery cells connected series-parallel.

nected in series parallel. Cells A and B are connected in series, also C and D. Then the positive and negative terminals of group CD are connected to the positive and negative terminals of group AB respectively. By comparing Fig. 60 with Fig. 53 it will be seen that the two groups in Fig. 60 are connected the same as the individual cells are in Fig. 53. In this way cells can be grouped to obtain any

voltage or current capacity desired, depending upon the number of cells so grouped.

The second method is to group the cells in parallel and then connect the groups in series, as in Fig. 61, which shows four cells connected in parallel-series. Cells *A* and *B* are

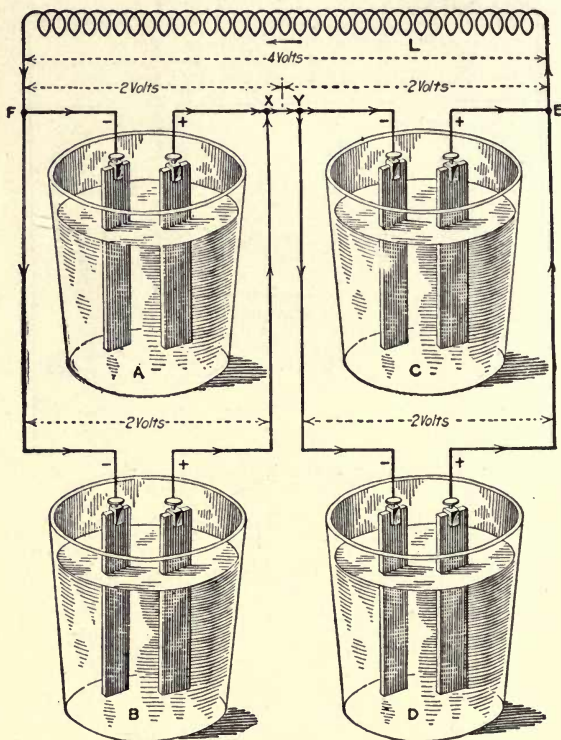

FIG. 61.—Four battery cells connected parallel-series.

connected in parallel, also cells *C* and *D*. Then the two groups are connected in series. It will be seen that if the connection *XY* is removed, the grouping of *A* and *B*, and *C* and *D*, will be the same as that in Fig. 53. The voltage between the outside leads in Figs. 60 and 61 is the same, but across the group it is different. In Fig. 60 two cells are connected in series in each group, which gives four volts across

their terminals, the sum of the volts of each two cells con-

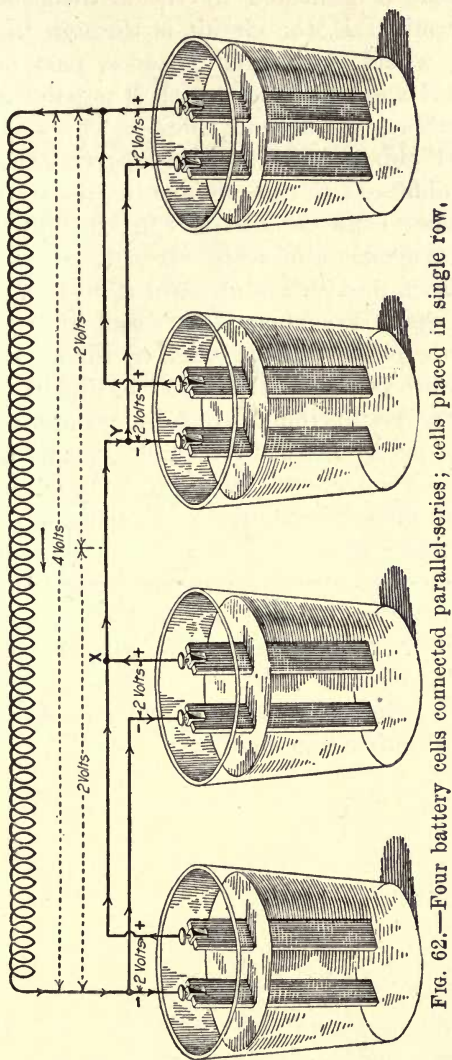

FIG. 62.—Four battery cells connected parallel-series; cells placed in single row,

nected in series. In Fig. 61 the two cells in each group are connected in parallel; consequently the volts across the

group is that of one cell, or in this case, two volts. The flow of the current is indicated by the arrowheads. Starting from the terminal *E*, the circuit is through the load *L*, to terminal *F*, where the current divides, part of it flowing through cell *A* and part through cell *B* to point *X*, where the current combines again and flows to *Y*, where it again divides, part going through *C* and part through *D*, after which it combines at *E*, thus completing the circuit. Fig. 62 shows the same connection as in Fig. 61, with a somewhat different arrangement of cells. It will be seen that cells *A* and *B*, also *C* and *D*, are grouped as in Fig. 54, and then the two groups are connected in series at *X* and *Y*. By tracing out the circuits as indicated by the arrowheads, they will be found to be identical to those in Fig. 61.

As for the results obtained from grouping cells, there is very little preference between the series-parallel and the parallel-series connection. However, in grouping lamps or other devices on a circuit, the series-parallel connection is given preference over the latter. The different combinations in which elements can be grouped on an electric circuit are almost innumerable, but all the various groupings are only a modification of series and parallel connections; consequently, by getting the idea of these two connections firmly fixed in the mind, it will greatly assist in an understanding of all other combinations.

CHAPTER IV

OHM'S LAW, SERIES AND PARALLEL CIRCUITS

Three Electric Units.—In the chapter on elements of electricity, we became acquainted with three electric units and the common types of electric circuits. The three electric units were the unit of pressure, "volt"; the unit of electric-current flow, "ampere"; and the unit of electrical resistance, "ohm." The volt corresponds to a force in pounds per square inch or a difference of temperature between two bodies or different parts of the same body. It is on just what pressure is that many misleading ideas are cultivated, in that manifestations of pressure are mistaken for the pressure itself, and when these manifestations are understood, it is considered that what pressure is, is also understood. Mechanical pressure, the manifestations of which we are all so familiar with, is just as mysterious as electrical pressure (volts). Pressure is defined as that which tends to produce motion. It may produce motion and it may not. To cause motion the opposing resistance, or, as it is commonly referred to, the reaction, must be overcome.

A steam boiler under pressure looks just the same as one that is cold, and unless some external manifestation is given such as the opening of the throttle valve and an engine is put in motion, or the opening of a cock from which a jet of steam or water is given out at high velocity, we would not be able to tell that the boiler is under pressure. The same thing is true of an electric circuit. A dead circuit looks the same as a live one. The only way that one can be told from the other is by some external manifestation. For example, if an electric lamp is connected to a circuit and it lights, we know that an electric pressure must exist between the ter-

minals to cause a current to flow and light the lamp. Or, again, if the terminals of the circuit are touched with the hand and a shock is received, it is realized that an electric pressure must exist to cause a current to flow and give the sensation that we feel. Therefore, in electricity as in mechanics, pressure is something that is only known to exist by its external manifestation.

Unit of Electric Current.—The ampere, the unit flow of electricity, is somewhat inexplicit, the same as the gallons in reference to the capacity of a pump. For example, the statement that a given pump discharges 10,000 gal. of water into a tank does not convey much of an idea as to the real capacity of the pump. It may have required a month, a week, a day or an hour for the pump to deliver the 10,000 gal. Each period would represent a different capacity pump. If the statement is made that the pump discharges 10,000 gal. into the tank in 10 min., we then know that the pump has a capacity of at least 1,000 gal. per min. Therefore, to get a clear conception of what the pump is capable of doing, it is necessary to know not only the gallons or cubic feet of fluid delivered, but also the time that was required.

The case of electricity is analogous to the foregoing. For example, if the terminals of a small battery cell are connected through an ammeter, it may set up a current of 20 or 30 amperes, but this is no indication of the capacity of the cell, for it may be capable of maintaining this rate of flow for a few minutes only. Or, again, a generator on a short-circuit may discharge an instantaneous current into the circuit of many thousand amperes, but this is no indication of what the generator is capable of doing. What we are most interested in, in all commercial machines, is the number of amperes that the machine will deliver continuously. Consequently, in electricity, as in the flow of a fluid, we must consider the time as well as the quantity to get a definite idea of the capacity of a device.

The unit quantity of electricity is called a coulomb, after the French physicist Charles Augustin de Coulomb. The

coulomb may be defined as the quantity of electricity that passes any cross-section of a circuit, in one second, when the current is maintained constant at one ampere strength. Hence, a current of electricity flowing through a circuit is measured in so many coulombs per second, just as the rate at which a quantity of fluid delivered by a pump is measured in so many gallons per second, or per minute. The coulomb is only the quantity of electricity as the gallon or pound is the quantity of matter. In general practice the current strength (amperes) and not the quantity (coulombs) is what we have to deal with; consequently, the coulomb is seldom mentioned.

Relation Between Volts, Amperes and Ohms.—It was pointed out in Chapter III that the three electrical units, volts, amperes and ohms, have been so chosen that one volt pressure impressed upon a circuit of one ohm resistance would cause a current of one ampere to flow. The relation between volts, amperes and ohms may be shown by the expression, $amperes = \frac{volts}{ohms}$; that is, the current flowing in a circuit is equal to the volts impressed on the circuit divided by the resistance of that circuit. This law was first defined by Dr. Georg Simon Ohm and may be said to be the beginning of the scientific study of electricity.

The three electrical units are represented by symbols; namely, volts by E , current by I and ohms by R . Therefore, in symbols the expression for the current is $I = \frac{E}{R}$. This formula may be transposed so as to read $R = \frac{E}{I}$; that is, the resistance of a circuit is equal to the volts divided by the current. Also, the expression may be derived, $E = RI$, which indicates that the voltage impressed upon a circuit is equal to the product of the resistance of the circuit times the current.

How to Remember Ohm's Law.—The importance of Ohm's Law makes it essential that the reader remember the foregoing formulas, or have some means for deriving them when needed. Any one of the formulas

might be memorized and transposed to give the other two, but this requires a knowledge of elementary algebra. Probably the easiest way to express this law and remember it is to write $\frac{E}{RI}$. When the three symbols are arranged in this form, all that is necessary to derive any one of the three formulas is to take the element that you wish to find out of the group and place it with an equality sign to the left of the remaining two. For example, to derive a formula for finding the value of E , take E from the top of the group and place it, with an equality sign between, to the left of the other two elements, thus: $E = RI$. To obtain an expression for the value of I , take I out of the group and place it, with an equality sign between, to the left of the remaining two, thus: $I = \frac{E}{R}$. Likewise for finding the value of R , take R out of the group and place it with an equality sign between in front of the remaining two symbols, thus: $R = \frac{E}{I}$. In each case the only change made in the original arrange-

ment of the symbols $\frac{E}{RI}$ was to take the symbol representing the quantity that was to be determined out of the group and place it in front of the equality sign. This makes it easy to recall any one of the three formulas.

The unit of electric pressure has a great many different names, including volts, electromotive force (e.m.f.), potential, drop of potential, difference of potential, etc., but they all mean one and the same thing.

Ohm's law, $I = \frac{E}{R}$, is a very simple expression, yet when a thorough knowledge is obtained of it in all its applications, the subject of direct current is quite thoroughly understood. Also, the knowledge will greatly assist in understanding alternating current.

Electric Generator.—Fig. 63 shows what is usually recognized as a symbol to represent a direct-current generator or motor. It might be stated here that an electric generator and dynamo is one and the same thing. Broadly speaking, a generator is anything that produces something. A gas producer is a generator of gas; a steam boiler, a generator of steam; and a dynamo, a generator of electricity. However the electric industry seems to have usurped the word generator for its own particular use, and now when we speak of a generator, it is intended to mean a dynamo unless otherwise specified.

In Fig. 64 is represented a direct-current generator connected to an external circuit. $E=110$ means that there are 110 volts at the generator terminal and would be indicated by the voltmeter shown connected between the positive and negative side of the circuit. $R=5$ indicates that the resistance of the circuit is 5 ohms, and $I=22$ reads that there are 22 amperes flowing in the circuit, which should be the reading of the ammeter connected in series in the line. The values on Fig. 64 have been chosen according to Ohm's law and necessarily would have to be for them to have any meaning. By applying the formulas already given, the relation between the values will be seen. For example, suppose we know the volts E and the resistance R and wish to find the current in amperes. Then, by using the expression, $\text{amperes} = \frac{\text{volts}}{\text{ohms}}$, or $I = \frac{E}{R}$,

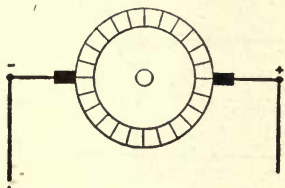

FIG. 63

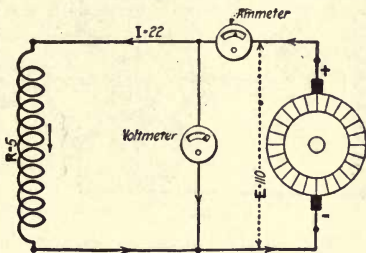

FIG. 64

FIG. 63.—Symbol for direct-current generator.

FIG. 64.—Five-ohm resistance connected to 110-volt generator.

we have $I = \frac{110}{5} = 22$ amperes, as indicated in the figure. On the other

hand, if the resistance R and the current I are known, we may find the volts by the formula, $\text{volts} = \text{ohms} \times \text{amperes}$, or $E = RI = 5 \times 22 = 110$ volts.

To find resistance R , $\text{ohms} = \frac{\text{volts}}{\text{amperes}}$, or $R = \frac{E}{I} = \frac{110}{22} = 5$ ohms.

Factors that Influence Flow of Current.—If 100 gal. of water per minute was flowing through a given size pipe at 50 lb. per sq. in., by increasing the pressure to 100 lb. per sq. in. we would expect to increase the amount. This is also true in an electric circuit, as indicated in Fig. 65. Here the conditions are the same as in Fig. 64, except that the volts E have been increased from 110 to 220. Then the current $I = \frac{E}{R} = \frac{220}{5} = 44$

amperes, as indicated. This is true in all cases. If the pressure is doubled on a given circuit, the current will be double.

At 50 lb. per sq. in., if 100 gal. of water per minute are flowing through a pipe, of 0.5 sq. in. cross-section, then through a pipe of one-half this

cross-section, 0.25 sq. in., we would expect to get only one-half as much or 50 gal. per min. This is also true in an electric circuit, as seen from a consideration of Fig. 66, which is the same as Fig. 64, except that the resistance of the circuit has been doubled; that is, increased from 5 to 10 ohms. The increase of resistance may have been accomplished by using a wire of the same material and length as in Fig. 64, but of one-half the cross-section; or the size of the wire may have remained the same as in Fig. 64, but the length doubled; or, in fact, all kinds of combinations can be made to obtain this result. In this problem the current

$$I = \frac{E}{R} = \frac{110}{10} = 11 \text{ amperes, which holds true with our water analogy.}$$

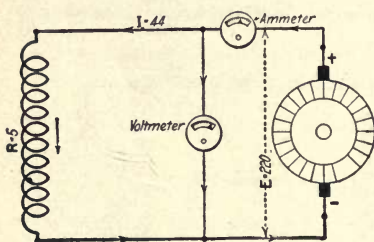

FIG. 65

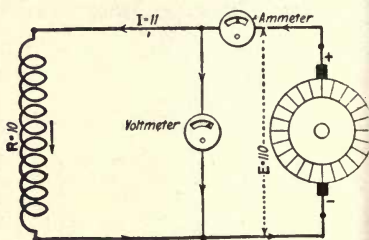

FIG. 66

FIG. 65.—Five-ohm resistance connected to 220-volt generator.

FIG. 66.—Ten-ohm resistance connected to 110-volt generator.

What we have seen in the example is just what would be expected; namely, that if the resistance is doubled and the pressure maintained constant, the current will be halved, or if the current is to be decreased by 2, through a given circuit, the voltage also must be decreased by 2.

In the foregoing example it has been seen that it is necessary to know two of the elements to find the third; that is, if the resistance of a circuit is to be calculated, it is necessary that the voltage and current be known, or if the amperes flowing in a circuit are to be determined, it will be necessary to know the volts and the resistance of the circuit.

Ohm's Law Problems.—1. Find the value of the electric pressure that must be impressed upon the terminals of a coil of 12.5 ohms resistance to cause a current of 15 amperes to flow through it.

One of the best ways to get a clear conception of an electrical problem is to make a diagram and put the known values on it. The conditions set forth in Problem 1 are shown in Fig. 67. The problem is to

find the value of the volts necessary to set up a current of 15 amperes through a coil of 12.5 ohms resistance. By Ohm's law, $E = RI = 12.5 \times 15 = 187.5$ volts.

2. A current of 6.6 amperes flows through an arc lamp connected to a 110-volt circuit; what is the resistance of the lamp?

This problem is shown in Fig. 68 and by Ohm's law,

$$R = \frac{E}{I} = \frac{110}{6.6} = 16.7 \text{ ohms.}$$

3. Determine what the ammeter readings should be, connected in a circuit having 35 ohms resistance, when the voltmeter indicated 157.5 volts, as shown in Fig. 69. The solution by Ohm's law,

$$I = \frac{E}{R} = \frac{157.5}{35} = 4.5 \text{ amperes.}$$

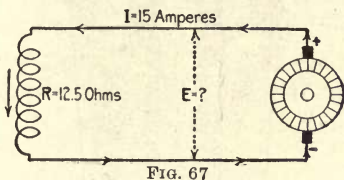

FIG. 67

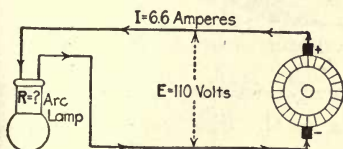

FIG. 68

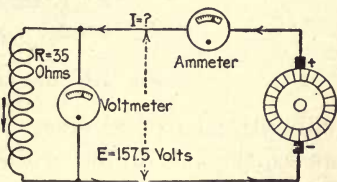

FIG. 69

FIGS. 67 to 69.—Single electric circuits.

4. A voltaic cell has an internal resistance of 0.25 ohm and a pressure of 1.75 volts between its terminals; if the two terminals of the cell are connected together by a wire of negligible resistance, what is the value of the current that will flow?

The voltaic cell shown in Fig. 70, has an internal resistance from the negative terminal around through the cell to the positive terminal of 0.25 ohm. If the terminals of the cell are connected together by a short piece of copper wire, the resistance of the latter will be so low that practically the total pressure of 1.75 volts will be effective in causing the current to flow through the resistance of the cell, and the current will

$$\text{be } I = \frac{E}{R} = \frac{1.75}{0.25} = 7 \text{ amperes.}$$

What Constitutes Electrical Resistance.—At this point a word on just what constitutes an electrical resistance will be in place. In the broad sense of the word, everything is an electrical resistance. Pieces of glass, porcelain or dry wood are resistances of extremely high value. On the other hand, a short piece of copper wire of large cross-section would be a resistance of extremely low value. Where a piece of glass or porcelain of given cross-section and length may have a resistance amounting to billions of ohms, the resistance of a piece of copper of the same length and cross-section would have a resistance of only one-millionth or one-

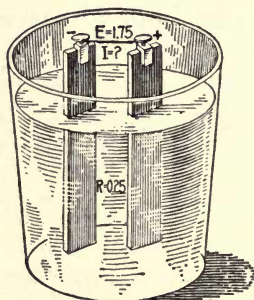

FIG. 70.—Battery cell short-circuited.

billionth part of an ohm. Nevertheless they are both resistances, the only difference being in the degree that each one opposes the flow of an electric current.

The two cases are extremes and are rarely referred to in practice as being resistances. Porcelain and glass and wood are usually called insulators, although when used on an electric circuit there is always a minute current flowing through them. The resistance of a piece of copper two or three inches in length, of ordinary cross-section, is usually spoken of as a negligible resistance, and therefore can always be neglected in practical problems. Coils wound with copper wire of small cross-section generally have considerable resistance, depending upon the size and length of the wire. Coils and other devices that are constructed for limiting the current through a device, or for other purposes, are

usually constructed of materials that have high resistance. High-resistance coils are generally wound of german silver or other special resistance wire. It is worth noting in passing that resistance wires are usually made from an alloy. Resistances that are made to carry large currents—that is, comparatively low resistances such as used for starting large motors—are usually made of cast-iron grids. From this it is seen that there may be an unlimited number of elements, all constituting a resistance to a greater or lesser degree.

Series Circuits.—In the problems considered so far, only a single element has been connected to the circuit. In practice most circuits are made up of several elements connected in various ways. One of the simplest ways of connecting different devices to a circuit is to group them in series. An element in a circuit may be considered as made up of a large number of sections in series. This will be made clear by reference to Fig. 71, where five separate circuits are shown

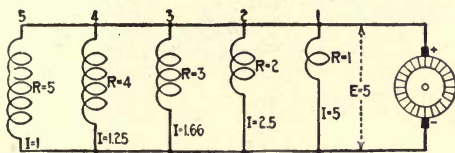

FIG. 71.—Five circuits in parallel.

of 1, 2, 3, 4, and 5 turns respectively. If the cross-section of the wire and the length of the turns are the same in each case, the most logical conclusion would be that the coil of two turns would have double the resistance of one turn. Likewise, the one having three turns will have three times the resistance of the one having one turn, and the one of five turns five times the resistance, etc. In other words, if elements are connected in series, the total resistance is the sum of the individual resistances so connected.

The principle illustrated in Fig. 71 is similar to increasing the length of a pipe line or the length of a coil of pipe through which a fluid is flowing. The longer the pipe is made, the smaller the amount of fluid that will flow through it at a given pressure. If it is assumed that each turn of

the coil shown in Fig. 71 has 1 ohm of resistance, then the resistance of the respective coils will be 1, 2, 3, 4 and 5 ohms as shown, and by applying Ohm's law, $I = \frac{E}{R}$, to each circuit when $E = 5$ volts, the current will be

5, 2.5, 1.66, 1.25 and 1 amperes respectively, as indicated.

In Fig. 72 is shown a circuit having two resistances R_1 and R_2 connected in series. In the preceding paragraph we found that the total resistance of a circuit consisting of two or more elements connected in series is equal to the sum of the individual resistances so connected.

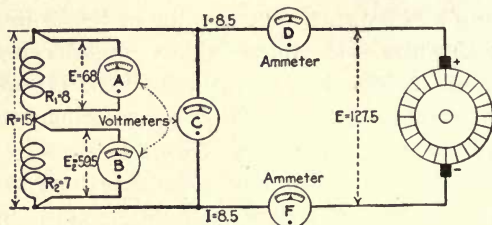

FIG. 72.—Two resistances in series.

Therefore, the total resistance R of the circuit shown in Fig. 72 may be found by the formula:

$$R = R_1 + R_2 = 8 + 7 = 15 \text{ ohms.}$$

The current in amperes equals the total volts divided by the total resistance; that is,

$$I = \frac{E}{R} = \frac{127.5}{15} = 8.5 \text{ amperes.}$$

Flow of Electric Current Compared to Water Flowing Through a Pipe.—Current flowing through a circuit is just the same as water flowing through a pipe, in the respect that, what flows in at one end must flow out at the other. In the problem, Fig. 72, 8.5 amp. leaves the positive terminal of the source and flows through the ammeter D , through resistance R_1 , then resistance R_2 , back through ammeter F and into the negative terminal of the generator, the same value of current entering the negative terminal that leaves the positive. Therefore the ammeter in the negative side will read the same as the one in the positive. The current is not used up in the circuit, and the same number of amperes (8.5) is effective in each resistance.

A hydraulic analogy of the conditions existing in Fig. 72 is shown in Fig. 73. In the latter the centrifugal pump, pressure gages, flow meters and water motors connected in series, represent respectively the generator, voltmeters, ammeters and resistances connected in series in the former. In Fig. 73, if the whole system is full of water and the pump is driven, the water will be set in motion, and consequently the water motors, which may be used to do mechanical work. All the water that flows out of the discharge will pass through meter *D*, through each motor in series, around through meter *F* and into the intake of the pump. Consequently each one of the flowmeters will read the same.

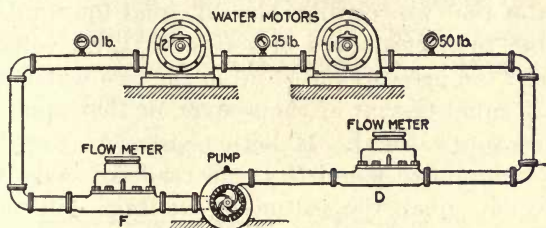

FIG. 73.—Hydraulic analogy of Fig. 72.

If both water motors in Fig. 73 are doing equal work and the pressure at the intake of motor No. 1 is 50 lb. per sq.in., the most logical conclusion would be that the pressure drop through each would be equal. That is, 25 lb. pressure would be used up in motor No. 1 and 25 lb. in motor No. 2. If a pressure gage is placed in the pipe line between the two motors, it would read the difference in pressure between the pressure at the intake and that used up in motor No. 1, or, as we assumed in this case, 25 lb. Likewise, a pressure gage at the discharge of motor No. 2 would read the difference between the pressure indicated on the gage between the two motors and that expended in motor No. 2. We have assumed that the remaining 25 lb. will be used up in motor No. 2, therefore the gage on the discharge of this motor will read zero. The foregoing assumption is not absolutely correct, because there is a loss of pressure in the pipe line itself. This

feature will be given further consideration in another chapter. Nevertheless, it serves to illustrate the conditions existing around the two resistances R_1 and R_2 in Fig. 72.

Voltage Drop Along a Circuit is Similar to Pressure Drop in Pipe Line.—In Fig. 72 there is 127.5 volts pressure impressed upon the two outside terminals of the two resistances R_1 and R_2 in series. If a voltmeter A is connected across the terminals of resistance R_1 , it will read the amount of pressure used up in causing the current to flow through this resistance. Likewise, if a voltmeter B is connected to the terminals of resistance R_2 , it will read the pressure necessary to cause the current to flow through this resistance, and the sum of the two readings should equal the total pressure across the two resistances in series, or 127.5 volts, just as the sum of the pressures used up in the two water motors in Fig. 73 is equal to that of the system, or that applied to the intake of motor No. 1. If both resistances were equal in Fig. 72, voltmeters A and B would read the same, but since they are not equal, the voltmeter readings will not be the same, the most logical conclusion being that the greatest pressure would be used in causing the current to flow through the highest resistance. A similar condition would exist in Fig. 73 if one water motor was doing more work than the other; we would expect that the greatest pressure drop would occur through the motor doing the most work.

The Value of the Volts Across Each Section of Resistance in Any Circuit May be Found by Ohm's Law, $E=RI$.—In Fig. 72 the volts drop across resistance R_1 may be expressed as $E_1=R_1I=8\times 8.5=68$ volts. The pressure across R_2 is $E_2=R_2I=7\times 8.5=59.5$ volts. The total pressure across the two resistances in series is equal to the sum of the volts across each individual resistance, or $E=E_1+E_2=68+59.5=127.5$, which checks up with the total voltage on the circuit.

Right here we come in contact with a very important point in the application of Ohm's law. Suppose that E_1 , the reading of voltmeter A , and I , the ammeter reading, are known, and it is desired to find R_1 .

This can be done by applying Ohm's law, $R=\frac{E}{I}$, or in this case the

expression becomes $R_1=\frac{E_1}{I}=\frac{68}{8.5}=8$ ohms. The same is true for R_2 ; that

is, $R_2 = \frac{E_2}{I} = \frac{59.5}{8.5} = 7$ ohms. Carrying this out one step farther, suppose we

know the value of the two resistances to be $R_1 = 8$ ohms and $R_2 = 7$ ohms, as in the figure, and then take voltmeter readings across each section and obtain for E_1 68 volts, and for E_2 59.5 volts. From either one of the

sets of values we may find the value of I ; that is, $I = \frac{E_1}{R_1} = \frac{68}{8} = 8.5$ amperes

or $I = \frac{E_2}{R_2} = \frac{59.5}{7} = 8.5$ amperes. Hence it is evident that it is not necessary

to know the total resistance of a circuit and the total voltage applied to it to obtain the current. All that is necessary to know is the value of one section of the resistance and the voltage drop across this section to determine the value of the current.

In applying Ohm's law formulas to finding the various values of the different sections of a circuit, care must be taken to use the values in the calculations pertaining to the section being considered.

In addition to finding the values indicated by the question marks on Fig. 74, state what each instrument will read and also find the value

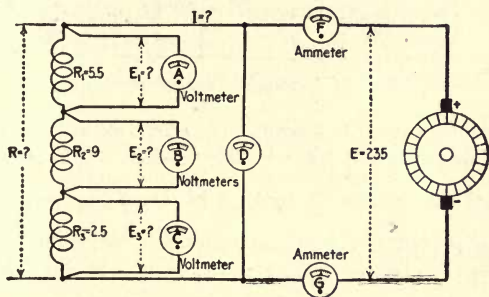

FIG. 74.—Three resistances in series.

of I by using the resistance and volts drop across each section, and check the voltage calculations by the sum of the volts across each section of resistance.

The first step in the solution is to find the total resistance. In the foregoing we found that the total resistance of two or more resistances connected in series was equal to the sum of the individual resistances. Hence, in Fig. 74, $R = R_1 + R_2 + R_3 = 5.5 + 9 + 2.5 = 17$ ohms. The current

$$I = \frac{E}{R} = \frac{235}{17} = 13.824 \text{ amperes.}$$

$$E_1 = R_1 I = 5.5 \times 13.824 = 76.03 \text{ volts.}$$

$$E_2 = R_2 I = 9 \times 13.824 = 124.42 \text{ volts.}$$

$$E_3 = R_3 I = 2.5 \times 13.824 = 34.56 \text{ volts.}$$

The value of I by using the volts dropped and the resistance of each section is $I = \frac{E_1}{R_1} = \frac{76.03}{5.5} = 13.824$ amperes; $I = \frac{E_2}{R_2} = \frac{124.42}{9} = 13.83$ amperes; $I = \frac{E_3}{R_3} = \frac{34.56}{2.5} = 13.824$ amperes.

The sum of the volts drop across the three sections is $E = E_1 + E_2 + E_3 = 76.03 + 124.42 + 34.56 = 235.01$ volts, against 235 volts given. Voltmeter A will read 76.03; B , 124.42; C , 34.56; and D , 235 volts. Both ammeters F and G will read the total current, or 13.824 amperes. In practice the instrument could not be read much closer than the even values given, or the next higher.

Parallel Circuits.—The most common method of grouping different devices on an electric circuit is to connect them in parallel. In Fig. 75

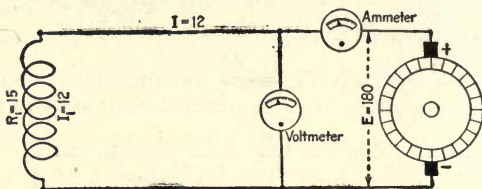

FIG. 75.—Single electric circuit.

is shown a simple circuit consisting of a single element R_1 connected to a source of electromotive force. The strength of the current for the value of volts and resistance given is by Ohm's law, $I_1 = \frac{E}{R_1} = \frac{180}{15} = 12$ amperes, as indicated. If a second resistance, R_2 , of 15 ohms is connected across the circuit, as in Fig. 76, there will also be 12 amperes

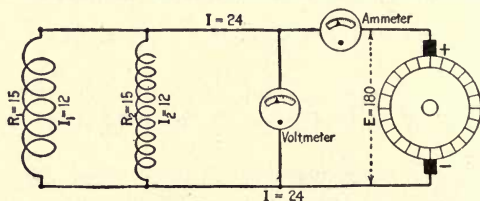

FIG. 76.—Two equal resistances in parallel.

passing through this path, making a total of 24 amperes flowing in the main circuit. That is, 24 amperes will flow from the positive terminal of the generator through the ammeter to R_2 . 12 amperes flowing

through R_2 and the other 12 through R_1 around to the negative terminal of R_2 , where the two currents join and flow back into the negative terminal.

Hydraulic Analogy of Parallel Circuit.—Fig. 77 shows a hydraulic analogy of Fig. 76, where the intake and discharge of a pump are connected to two large pipes, which are connected together by several small pipes. If the system is full of water and only valve No. 1 is open, a current of water will flow depending upon the size of this pipe and the pressure. Open valve No. 2, and if this pipe is the same size as No. 1, double the amount of water will flow if the pressure is maintained constant.

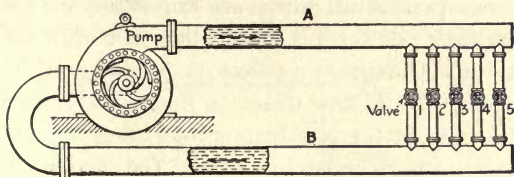

FIG. 77.—Water analogy of five circuits in parallel.

That is, a given quantity of water flows down pipe A, one-half of it passing through connection No. 1 and the other half through connection No. 2, where the two currents join and flow back through B to the pump; this is identical to the flow of the current in Fig. 76.

The Total Resistance of Any Circuit is Equal to the Total Voltage Divided by the Total Current.—In Fig. 76 the total resistance is

$$R = \frac{E}{I} = \frac{180}{24} = 7.5 \text{ ohms.}$$

It will be seen that this value, 7.5, is one-half

that of R_1 or R_2 . In other words, $R = \text{either } R_1 \text{ or } R_2 \text{ divided by 2, the number of resistances in parallel, in this case two. This is true in all cases where equal resistances are connected in parallel. The joint resistance of the group is equal to the resistance of one of the individual circuits divided by the number connected in parallel.}$

To further illustrate this problem, Fig. 78 is given; here five lamps of 20 ohms each are connected across a 120-volt circuit. By Ohm's law,

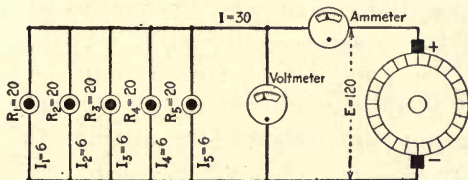

FIG. 78.—Five lamps in parallel.

each lamp will take $I = \frac{E}{R_1} = \frac{120}{20} = 6$ amperes. Then the total current will equal the sum of that in each circuit, or 30 amperes. The joint resistance

is equal to the total volts divided by the total current. In this problem the joint resistance $R = \frac{E}{I} = \frac{120}{30} = 4$ ohms. The joint resistance is also equal to the resistance of one circuit divided by the number of circuits in parallel, or $\frac{20}{5} = 4$ ohms.

Referring again to Fig. 77, if by opening valve No. 1 six gallons per second flows around through the system, when all valves are open, if all pipes are the same size, five times six, or 30 gallons per second would flow through the system. In this analogy the pressure has been assumed to remain constant; therefore, if five times as much water flows in the circuit under the latter conditions as under the former, the resistance of the path must have been reduced by five. But the resistance offered to the flow of each individual path in Fig. 77 has not been changed. Likewise in Fig. 78 the resistance of each individual circuit has not been changed; the combination of the five equal resistances in parallel only produced an equivalent resistance, equal to that of one divided by the number in parallel, or in this case one-fifth that of one individual circuit.

Joint Resistance of Two or More Unequal Resistances in Parallel.—From the foregoing it is evident that the problem of calculating the joint resistance of a circuit made up of a number of equal resistances connected in parallel is a simple one. However, when the resistances of each individual circuit are not equal, a different method must be employed. One way of obtaining the joint resistance of a circuit composed of two or more unequal resistances in parallel would be to assume a given voltage applied to the circuit and then apply Ohm's law; finding the value of the current that would flow in each circuit for this voltage, and then finding the joint resistance by dividing the voltage by the total current.

In Fig. 79 are shown two resistances, R_1 and R_2 , of 20 and 25 ohms respectively, connected in parallel across a 150-volt circuit. The current passing through R_1 is $I_1 = \frac{E}{R_1} = \frac{150}{20} = 7.5$ amperes, and in R_2 is $I_2 = \frac{E}{R_2} = \frac{150}{25}$

=6 amperes. The total current equals $I_1 + I_2 = 7.5 + 6 = 13.5$ amperes, and the total resistance R , equals the total volts E divided by the current I ; that is, $R = \frac{E}{I} = \frac{150}{13.5} = 11.11$ ohms.

Resistance and Conductance.—In reference to the flow of electricity all substances may be considered as possessing two properties—first, the property which opposes the flow of an electric current (resistance), and, second, the property that allows the flow of, or conducts, an electric current, called conductance. In any material, if the resistance is high conductance must be low, or conversely, if the resistance is low the conductance must be high. The relation of the resistance to the conductance

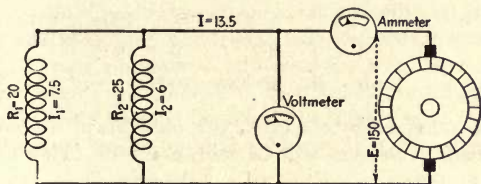

FIG. 79.—Two unequal resistances in parallel.

of a circuit is expressed as follows: If R represents the resistance of a circuit, the conductance will be represented by $\frac{1}{R}$, and is usually expressed, the conductance is equal to the reciprocal of the resistance. Then, in Fig. 79, where $R_1 = 20$, the conductance of this circuit will equal $\frac{1}{R_1} = \frac{1}{20} = 0.05$ mhos; $R_2 = 25$, then the conductance of this circuit will equal $\frac{1}{R_2} = \frac{1}{25} = 0.04$ mhos. The name mho, ohm spelled backward, has been proposed for the unit of conductance.

The total conductance of a circuit is equal to the sum of the conductances connected in parallel. Then in the problem, Fig. 79, conductance = $\frac{1}{R_1} + \frac{1}{R_2} = \frac{1}{20} + \frac{1}{25} = \frac{5+4}{100} = \frac{9}{100} = 0.09$ mhos. Since conductance

is the inverse of resistance, resistance must be the inverse of conductance, that is, $resistance = \frac{1}{conductance}$. Therefore in this problem the joint resistance, $R = \frac{1}{total\ conductance} = \frac{1}{\frac{9}{100}} = \frac{100}{9} = 11.11$ ohms, which is the

same as obtained by Ohm's law.

Formula for Finding Joint Resistance.—The foregoing method of finding the joint resistance may be expressed by a formula. We have just seen

that the conductance of a circuit consisting of several resistances in parallel is, $conductance = \frac{1}{R_1} + \frac{1}{R_2} + \frac{1}{R_3} \dots$, depending upon the number in parallel. The resistance R being equal to $\frac{1}{conductance}$ may be expressed as

$$R = \frac{1}{\frac{1}{R_1} + \frac{1}{R_2} + \frac{1}{R_3} \dots}$$

Applying this to our problem,

$$R = \frac{1}{\frac{1}{R_1} + \frac{1}{R_2}} = \frac{1}{\frac{1}{20} + \frac{1}{25}} = \frac{1}{\frac{9}{100}} = \frac{100}{9} = 11.11 \text{ ohms,}$$

the same as obtained by the other two methods of working the problem. The foregoing expression will be known in the following as the joint-resistance formula

In Fig. 80, in addition to finding the values indicated by the question marks, find the joint resistance of the circuit by Ohm's law; check the

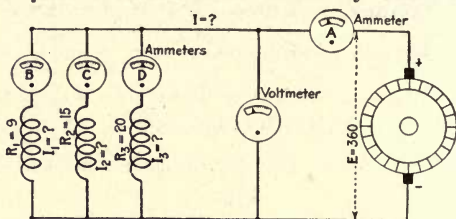

FIG. 80.—Three unequal resistances in parallel.

results by the joint-resistance formula, and indicate what each ammeter will read.

In this problem, Fig. 80,

$$I_1 = \frac{E}{R_1} = \frac{360}{9} = 40 \text{ amperes;}$$

$$I_2 = \frac{E}{R_2} = \frac{360}{15} = 24 \text{ amperes;}$$

and

$$I_3 = \frac{E}{R_3} = \frac{360}{20} = 18 \text{ amperes;}$$

$$I = I_1 + I_2 + I_3 = 40 + 24 + 18 = 82 \text{ amperes.}$$

The joint resistance R of the circuit by Ohm's law is

$$R = \frac{E}{I} = \frac{360}{82} = 4.39 \text{ ohms.}$$

By the joint-resistance formula,

$$R = \frac{1}{\frac{1}{R_1} + \frac{1}{R_2} + \frac{1}{R_3}} = \frac{1}{\frac{1}{9} + \frac{1}{15} + \frac{1}{20}} = \frac{1}{\frac{41}{180}} = 4.39 \text{ ohms,}$$

the same as by the Ohm's law method. Ammeter B will read the current flowing in the branch of the circuit that it is connected in, that is, the current flowing through R_1 , or 40 amperes; ammeter C will read 25 amperes, the current passing through R_2 ; ammeter D will read 18 amperes, the current flowing in R_3 ; and ammeter A will read the total current flowing in the circuit—the sum of the readings of B , C , and D , or 82 amperes.

Hydraulic Analogy of a Parallel Circuit.—The conditions in the problem, Fig. 80, are represented by the hydraulic analogy, Fig. 81, where a pump

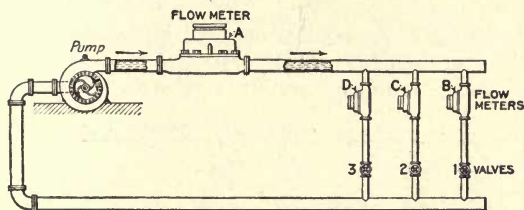

FIG. 81.—Water analogy of Fig. 80.

is shown with its discharge and intake connected together in a pipe system. The three branch circuits, 1, 2 and 3, Fig. 81, represent respectively, R_1 , R_2 and R_3 , Fig. 80. The flow meters A , B , C and D in the latter represent respectively, the ammeters A , B , C and D in the former. If the pipe system is full of water and the pump driven, meter B will read the quantity of fluid flowing through circuit No. 1, C that flowing through No. 2, D that passing through No. 3 and A the total indicated by B , C and D , the same as ammeter A reads the total current passing through ammeters B , C and D , Fig. 80.

There can be no mistaking what an ammeter should read if the circuit is traced from the positive terminal around to the negative. In Fig. 80, starting from the positive terminal and tracing the circuit through R_1 , we find that the current passes through ammeters A and B , but does not go through D or C . Likewise, in following the circuit through R_2 the current in this circuit passes through ammeters A and C , but not through B and D , that through R_3 passes through ammeters A and D , but not through B and C . In each case the current of only one circuit passes

through ammeters *B*, *C* and *D*, where the current of all three circuits passes through ammeter *A*. Consequently ammeters *B*, *C* and *D* will read only the current of the individual circuits that they are connected in, and ammeter *A* reads the total of the three.

Two Methods of Working Out Joint-Resistance Problems.—In the problem, Fig. 82, the resistance may be found by the joint-resistance formula,

$$R = \frac{1}{\frac{1}{R_1} + \frac{1}{R_2} + \frac{1}{R_3} + \frac{1}{R_4} + \frac{1}{R_5}} = \frac{1}{\frac{1}{6} + \frac{1}{15} + \frac{1}{9} + \frac{1}{5} + \frac{1}{7}} = \frac{1}{\frac{433}{630}} = \frac{630}{433} = 1.45 \text{ ohms.}$$

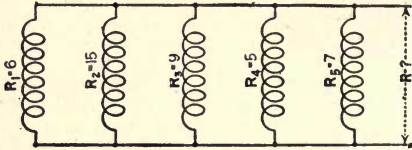

FIG. 82.—Five unequal resistances in parallel.

In the foregoing it was pointed out that in a simple parallel circuit, like that shown in the figure, the joint resistance could always be found by assuming some convenient voltage applied to the circuit and then

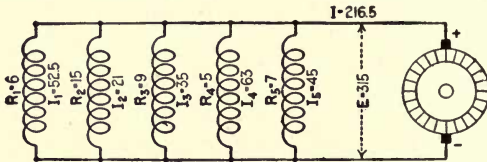

FIG. 83.—Same as Fig. 82 connected to source of voltage.

applying Ohm's law. In this case assume that the voltage equals 315, as indicated in Fig. 83. Then

$$I_1 = \frac{E}{R_1} = \frac{315}{6} = 52.5 \text{ amperes;}$$

$$I_2 = \frac{E}{R_2} = \frac{315}{15} = 21 \text{ amperes;}$$

$$I_3 = \frac{E}{R_3} = \frac{315}{9} = 35 \text{ amperes;}$$

$$I_4 = \frac{E}{R_4} = \frac{315}{5} = 63 \text{ amperes;}$$

and

$$I_5 = \frac{E}{R_5} = \frac{315}{7} = 45 \text{ amperes.}$$

The total current I equals the sum of the currents in the individual circuits or,

$$I = I_1 + I_2 + I_3 + I_4 + I_5 = 52.5 + 21 + 35 + 63 + 45 = 216.5 \text{ amperes.}$$

By Ohm's law the joint resistance is $R = \frac{E}{I} = \frac{315}{216.5} = 1.45 \text{ ohms.}$ This

checks up with the result obtained by the joint-resistance formula.

In the problem, Fig. 84, we have two circuits in parallel, each circuit made up of two resistances in series; that is, r_1 and r_2 are connected in series forming the circuit R_1 , and r_3 and r_4 are connected in series forming the circuit R_2 . The first thing to do in this problem is to find the resistance of each individual circuit. We found out in a previous problem that the total resistance of a circuit composed of two or more resistances

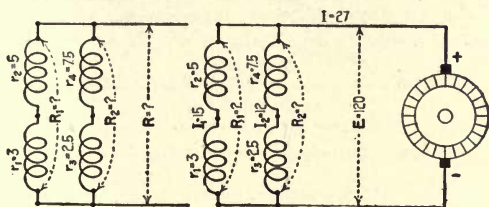

FIG. 84

FIG. 85

FIG. 84.—Four unequal resistances connected series-parallel.

FIG. 85.—Same as Fig. 84 connected to source of voltage.

connected in series is equal to the sum of the individual resistances so connected. Hence, $R_1 = r_1 + r_2 = 3 + 5 = 8 \text{ ohms}$, and $R_2 = r_3 + r_4 = 2.5 + 7.5 = 10 \text{ ohms}$. The joint resistance

$$R = \frac{1}{\frac{1}{R_1} + \frac{1}{R_2}} = \frac{1}{\frac{1}{8} + \frac{1}{10}} = \frac{1}{\frac{18}{80}} = \frac{80}{18} = 4.44 \text{ ohms.}$$

In this case the joint resistance may also be found by Ohm's law, as in the other problems. Assume that $E = 120$, as shown in Fig. 85. Then

$$I_1 = \frac{E}{R_1} = \frac{120}{8} = 15 \text{ amperes, and } I_2 = \frac{E}{R_2} = \frac{120}{10} = 12 \text{ amperes.}$$

The total current $I = I_1 + I_2 = 15 + 12 = 27 \text{ amperes}$, and the joint resistance is $R = \frac{E}{I} = \frac{120}{27} = 4.44 \text{ ohms}$, the same as obtained in the foregoing.

Volts Drop Across a Circuit.—The following is a question that was received from a reader and is pertinent to these studies: What would be the voltage after passing through a bank of lamps connected in series? The lamps take 0.5 ampere on a 120-volt circuit.

In answer to this question it might be said that voltage does not pass through lamps or anything else, but is used up in causing a current to flow through the circuit. In Fig. 86 are shown two water motors connected in series in a pipe system assumed to be filled with water, with a pump to cause the fluid to flow. If the pump is driven, it will create a certain difference in the pressure between its discharge and intake, which will cause the water to circulate and drive the motors. As was pointed out in the foregoing, if both motors are the same size, half of the pressure will be used up in causing the water to flow through motor No. 1 and half used up in motor No. 2. Or, theoretically, if we had 50 lb. pressure at the intake of motor No. 1, the pressure would be only 25 lb. at the intake of motor No. 2 and 0 at its discharge, as shown.

Referring to Fig. 87 and assuming that we have two such lamps as mentioned in the question connected in series across a 120-volt circuit, these lamps take 0.5 ampere on a 120-volt circuit, therefore the resistance of each lamp, by Ohm's law, is $r = \frac{E}{I} = \frac{120}{0.5} = 240$ ohms, as indicated on the figure. The total resistance of the circuit would be the sum of the resistance of the two lamps, or $240 + 240 = 480$ ohms. The current flowing through the two lamps connected in series is $I = \frac{E}{R} = \frac{120}{480} = 0.25$ ampere. In this calculation we find out why two lamps will burn dim when connected in series across a circuit having a voltage equal to the rated volts of one lamp. On the 120-volt circuit one lamp would take $I = \frac{E}{r} = \frac{120}{240} = 0.5$ ampere, as mentioned in the question. But when the two lamps are connected in series, the resistance of the circuit is double and the current is only one-half that taken by one alone, or in this case 0.25 ampere.

There is assumed to be 0.25 ampere flowing from the positive terminal, through the two lamps in series and back to the negative side of the line, just as a certain quantity of water was assumed to be flowing from the discharge of the pump in Fig. 86, through the two motors in series and back into the intake of the pump. In the lamp circuit it was not voltage that passed through the circuit any more than it was pressure, pounds per square inch, that passed through the pipe system. In each condition the pressure was only a medium that caused a quantity to flow through a given path. Through the pipe system we call this quantity water and through the lamp circuit electricity.

The volt drop across each lamp equals the resistance times the current, or $E_1 = r_1 I = 240 \times 0.25 = 60$ volts, likewise $E_2 = r_2 I = 240 \times 0.25 = 60$ volts; that is, 60 volts of the pressure is used up in causing the current to flow through lamp No. 1 and 60 volts in lamp No. 2, the pressure being all expended by the time the current reaches the negative terminal of No. 2,

just as the pressure was all expended by the time the current of water reached the discharge of motor No. 2, Fig. 86. Hence, it is seen that pressure is something that does not flow, but is used up in causing something else to be transmitted from one position to another.

Determining Value of Current by Volts Drop and Resistance of Section of a Circuit.—In addition to finding the values indicated by the interrogation marks, Fig. 88, find the joint resistance R and check the answer; also indicate what each instrument should read.

The first and only element that we can find is the current I_1 , flowing through circuit R_1 . In the foregoing we found out that it was not

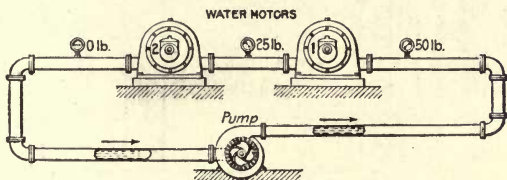

FIG. 86

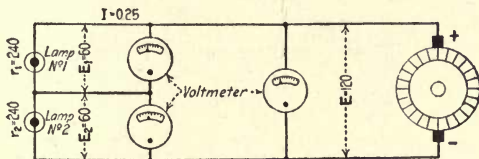

FIG. 87

FIGS. 86 and 87.—Illustrate pressure drop along an electric circuit.

necessary to know the total volts and resistance of a circuit to determine the value of the current flowing through it. All that is required is to know the resistance of a section and the volts drop across this section.

Referring to circuit R_1 there is given the value r_2 and E_2 , for the middle section of the resistance. Hence, $I_1 = \frac{E_2}{r_2} = \frac{75}{15} = 5$ amperes. Knowing

$I_1 = 5$ amperes, $r_1 = 5$ and $r_3 = 8$, we may find E_1 and E_2 by Ohm's law. $E_1 = r_1 I_1 = 5 \times 5 = 25$ volts, and $E_3 = r_3 I_1 = 8 \times 5 = 40$ volts. The total volts E equals the sum of the volts drop across each section, or $E = E_1 + E_2 + E_3 = 25 + 75 + 40 = 140$ volts. The total resistance R of circuit No. 1 is equal to the sum of the resistances of the three sections, or $R_1 = r_1 + r_2 + r_3 = 5 + 15 + 8 = 28$ ohms.

The solution of this part of the problem may be checked by Ohm's law, $I_1 = \frac{E}{R_1} = \frac{140}{28} = 5$ amperes. This checks with the value obtained by $\frac{E_2}{r_2}$.

Considering circuit R_2 , 90 volts of the 140 volts total pressure is used up across resistance r_5 , then the remainder of the 140 volts must be expended across r_4 . Hence, E_4 , the voltage across r_4 , must equal the

difference between E and E_5 ; that is, $E_4 = E - E_5 = 140 - 90 = 50$ volts. $I_2 = \frac{E_4}{r_4} = \frac{50}{5} = 10$ amperes, and $r_5 = \frac{E_5}{I_2} = \frac{90}{10} = 9$ ohms. The total resistance of this circuit, $R_2 = r_4 + r_5 = 5 + 9 = 14$ ohms. We may again check our work by Ohm's law, $R_2 = \frac{E}{I_2} = \frac{140}{10} = 14$ ohms, which is the same as obtained by the other method.

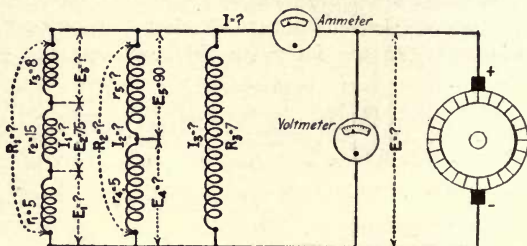

FIG. 88.—Resistances connected in series and the circuits in parallel.

In circuit R_3 , $I_3 = \frac{E}{R_3} = \frac{140}{7} = 20$ amperes. The total current $I = I_1 + I_2 + I_3 = 5 + 10 + 20 = 35$ amperes. The joint resistance

$$R = \frac{1}{\frac{1}{R_1} + \frac{1}{R_2} + \frac{1}{R_3}} = \frac{1}{\frac{1}{28} + \frac{1}{14} + \frac{1}{7}} = \frac{1}{\frac{1}{7}} = 7 = \frac{28}{4} = 7 \text{ ohms.}$$

By Ohm's law,

$$R = \frac{E}{I} = \frac{140}{35} = 4 \text{ ohms;}$$

this checks with the joint-resistance method.

For simple parallel circuits the Ohm's law method of finding the joint resistance is the simplest and the one generally used; but in complex circuits consisting of elements grouped in both parallel and series, it is not possible to apply Ohm's law and the conductance method has to be used.

CHAPTER V

ENERGY, WORK AND POWER

Energy the Ability for Doing Work.—In considering the effort developed by any power-producing device, there are three elements to take into account—energy, work and power. Before considering the energy transmitted by an electric current, it will be necessary to give heed to the significance of these three items. Energy is defined as the ability or capacity for doing work. Air stored under pressure is an example of energy, or the ability to do work. As long as the air is confined in a tank, it cannot do any work. In order that work may be done, it may be admitted to the cylinder of a locomotive, where if the proper conditions exist, the energy stored in the air by virtue of the pressure will do the work of driving the locomotive and its load. Again, the air may be admitted to the cylinder of a rock drill and do the work of driving the drill, or it may be used to do the work of operating a multiplicity of different devices.

Another example is a spring under tension ready to be released, which may, when released, do the work of moving a body from one position to another.

Steam Under Pressure Possesses Energy.—Steam stored under pressure in a boiler possesses energy—the capacity for doing work. Unless the steam is allowed to enter the cylinder of an engine or other devices and put these devices in motion, no work is done. A horse has stored in his muscles the ability or capacity for drawing heavy loads, but as long as he is allowed to remain idle he does not do any work; nevertheless, he possesses the capacity for doing work, or energy that may be converted into work. From the fore-

going it is seen that in order that work be done, a force must overcome a resistance; that is, a body must be moved. Thus work is defined as the expanding of energy, or we may say work is done when a force overcomes a resistance.

It is not enough that the throttle valve be opened and steam admitted to the cylinder of an engine that work be done, for the engine may be on dead-center or the fly-wheel blocked so that it cannot turn. In such a case we would have the force of the steam acting upon the piston, but no work is done because the force has not overcome the resistance offered by the mechanical connection to the piston. All that would occur in the case cited would be a slight increase in the space to be filled with steam. On the other hand, if conditions are such that the engine is put in motion, then work is done, or in other words, the opposition offered by the engine and its load to the force of the steam has been overcome.

Foot-Pound Unit of Work.—Work is expressed as the product of a force in pounds times distance in feet. This may also be expressed as, $work = pounds \times feet = foot-pounds$; the product of a force in pounds \times distance in feet being called foot-pounds, and the work done by a force of one pound acting through a distance of one foot is called the unit of work, or one foot-pound. Expressing this in another way, one foot-pound is the work necessary to raise one pound one foot.

Defining Unit of Power.—The simple statement that 1,000 lb. has been raised 50 ft.—that is, 50,000 ft.-lb. of work has been done—does not give any idea how hard the individual or device worked in transferring the 1,000 lb. from one position to the other. For example, suppose the weight was 10 bags of cement, of 100 lb. each, and a workman carried them up a ladder to a floor 50 ft. from the ground. The knowledge that the task had been performed does not indicate how hard the man worked in performing the work. He may have done the job in an hour, two hours or ten hours; each period would represent a different rate of doing the work. This is

where power fits in. Power is the rate of doing work, or in other words the rate of expending energy, and is equal to the work divided by time. Thus; $power = \frac{force \times distance.}{time}$
 $= \text{foot-pound-minutes or seconds.}$ The time element in the formula is expressed in minutes or seconds. A foot-pound-minute, the unit of power, is defined as being the work necessary to raise one pound one foot in one minute, and, the foot-pound-second, the work necessary to raise one pound one foot in one second.

In the example of the man carrying the cement, the work performed was the same in either case irrespective of the time; that is, 1,000 lb. was raised 50 ft., or $1,000 \text{ lb.} \times 50 \text{ ft.} = 50,000$ foot-pounds of work was performed. When we come to consider the time element, each one will represent a different rate of doing work. For example, if the man did the work in one hour (60 min.), the rate of doing the work, $power = \frac{weight \times distance}{time} = \frac{1,000 \times 50}{60} = 833$ foot-pound-minutes. If the time required is two hours (120 min.), then the power developed $= \frac{1,000 \times 50}{120} = 417$ foot-pound-minutes. Hence it is seen that if the time element is double for doing a given piece of work, the power developed, the rate of doing work, is only one-half. In other words, the individual or device is only working one-half as hard.

Definition of Energy, Work and Power.—We may summarize the definition of the three elements thus: *Energy is the capacity or ability for doing work; work is the expending of energy (this is accomplished when a force overcomes a resistance); and power is the rate of doing work, or the rate at which energy is expended.*

Horsepower Defined by James Watt.—Power-developing devices are usually rated in horsepower. The horsepower was defined by James Watt, as the result of his experiments with strong draft horses, as being the equivalent of the work necessary to raise 33,000 pounds one foot in one minute, or

550 pounds in one second. This may be expressed as the work necessary to raise 330 lb. 100 ft. in one minute. This unit was adopted by Watt in the rating of his steam engines and has been used since then as a unit for rating of power equipment. Since the horsepower = 33,000 foot-pound-minutes, the rate of doing work of any device expressed in

$$\text{horsepower} = \frac{\text{foot-pound-minutes}}{33,000}$$

When Energy is Expended Heat is Produced.—Whenever energy is expended—that is, work done—it manifests itself in the form of heat. The energy expended in overcoming the friction of a bearing manifests itself by heating up the metal, and if the bearing is not properly lubricated to reduce the friction, the expenditure of energy necessary to overcome the friction would be so great as to heat the metal to the melting point and destroy the bearing. If a piece of metal is struck a blow with a hammer, it is heated; here the energy expended in the blow is converted into heat where the blow is struck. These examples are almost unlimited. The one that is most familiar to us all is that when coal is burned in a furnace under a boiler, the energy stored in the coal is liberated in the form of heat and passes into the water, converts the water into steam, which in turn transmits the energy to the cylinder of the engine where it is utilized to drive the engine and its load. From these examples it will be seen that there is a very close connection between work and heat. In fact, work cannot be performed unless a certain amount of heat is produced.

Mechanical Equivalent of Heat.—After James Watt's time there flourished an English physicist, by the name of James Prescott Joule, who by experiments determined the amount of heat produced in doing a given amount of work or, as it is usually called, the mechanical equivalent of heat. The principle of the apparatus used by Joule in his experiments is illustrated in Fig. 89. The weights *W* were raised by turning the crank *C*, and then, by allowing the weights to fall, the paddle wheel *P* was caused to revolve in

the tank *T*, which was filled with water. The weights *W* in pounds, minus the friction in the connected mechanism, times the distance in feet through which they fell, would give the work done on the paddle wheel *P* in overcoming the resistance of the water. Then by taking the temperature of the water before and after the experiment, the heat equivalent of the work expended on the paddle wheel was determined. From his experiments Joule came to the conclusion that when 772 foot-pounds of work was expended in one pound of water, its temperature would be increased one

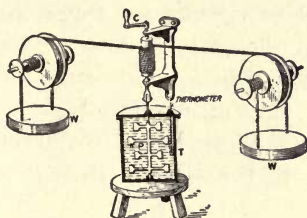

FIG. 89.—Apparatus for determining mechanical equivalent of heat.

degree F. Joule's apparatus was crude; consequently, as would be expected, the results were not accurate. Later experiments have shown that the correct value is 778 foot pounds. The difference between the two values is very small, when consideration is given to the conditions under which Joule had to conduct his experiments.

British Thermal Unit.—The work necessary, when performed on one pound of water, to increase its temperature one degree F. (778 foot-pounds), is called a British thermal unit (B.t.u.). Since, when 778 foot-pounds of work is performed in one pound of water, the temperature of the latter is increased one degree F., if one horsepower (33,000 foot-pounds) is done the temperature of one pound will be increased $\frac{33,000}{778} = 42.42$ deg. In other words, one horsepower is equivalent to the heat necessary to increase the temperature of one pound of water 42.42 deg.

Power of an Electric Circuit.—The rate of which energy is expended in an electric circuit (power) is equal to the current in amperes multiplied by the volts impressed upon the circuit. The product of volts times amperes is called watts, after James Watt, the Scottish inventor, who was responsible for much of the early development of the steam engine. That is, electric power, watts = amperes \times volts. The symbol for watts is W and the formula is written $W = EI$. One kilowatt, KW , equals 1,000 watts, therefore,

$$KW = \frac{W}{1,000}$$

Whenever an electric current flows through a circuit, it manifests itself in the form of heat. It was by taking advantage of this fact that a connecting link was established between electrical and mechanical power.

Heat Equivalent of an Electric Current.—By use of an apparatus similar to that shown in Fig. 90, which shows a

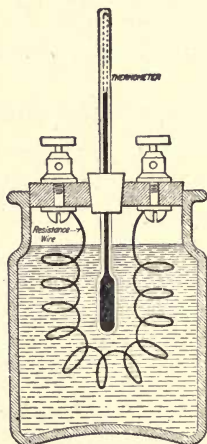

FIG. 90.—Apparatus for determining heat of an electric current.

vessel filled with water in which a coil of resistance wire is immersed, the heat equivalent of an electric current was determined. By passing an electric current through the coil it was found that when energy is expended at the rate of 746 watts, for one minute, the temperature of a given volume

of the water is increased the same amount as when one mechanical horsepower of work is done upon it (33,000 ft.-lb.-min.); namely, the temperature of one pound of water is increased 42.42 deg. F. Hence we may say that 746 watts of electrical power is the equivalent of one mechanical horsepower. Therefore,

$$\text{electrical horsepower} = \frac{\text{Watts}}{746} = \frac{W}{746}. \quad \text{Since } W = EI, \text{ we}$$

$$\text{may write, } \text{electrical horsepower} = \frac{EI}{746}.$$

An electrical motor, when connected to a 220-volt circuit takes 37.5 amperes from the line. Find the power supplied to the motor in watts and electrical horsepower.

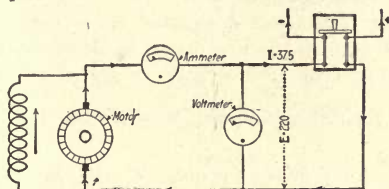

FIG. 91

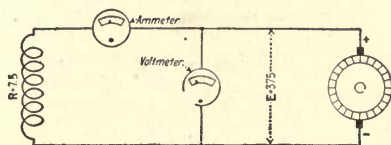

FIG. 92

FIGS. 91 and 92.—Elementary circuits.

Fig. 91 shows the condition existing in the circuit in the problem; namely, a 220-volt circuit with 37.5 amperes flowing through it. The watts equals volts times the current; that is, $W = EI = 220 \times 37.5 = 8,250$.

$$\text{Electrical horsepower} = \frac{W}{746} = \frac{8,250}{746} = 11 \text{ horsepower,}$$

and

$$KW = \frac{W}{1,000} = \frac{8,250}{1,000} = 8.25 \text{ kilowatts.}$$

A 7.5-ohm resistance is connected to a 375-volt circuit. Find the power in watts and electrical horsepower supplied to the resistance.

The values in the problem are given in Fig. 92. Before we can find

the power in watts, the current in amperes must be known. Since the value of E and R are known, the current may be determined by Ohm's law.

Hence $I = \frac{E}{R} = \frac{375}{7.5} = 50$ amperes. The watts $W = EI = 375 \times 50 = 18,750$

watts. *Electrical horsepower* $= \frac{W}{746} = \frac{18,750}{746} = 25.3$ horsepower, and the

kilowatts $KW = \frac{W}{1,000} = \frac{18,750}{1,000} = 18.75$.

The volts $E = RI$, and the watts $W = EI$. By substituting the equivalent RI for E in the second formula, $W = RI \times I = RI^2$, or, as it is usually written, $W = I^2R$. In this problem the value of the resistance R is 7.5 ohms and the current I was calculated to be 50 amperes; then watts from the formula, $W = I^2R = 50 \times 50 \times 7.5 = 18,750$ watts. This value checks with that obtained by the product of volts and amperes, which shows that the expression is correct.

The expression I^2R (read I squared R) is very important, as it is generally used to express the heat losses in electrical devices, these losses being referred to as I squared R losses (I^2R losses). Another expression

for the watts is derived as follows: $W = EI$, and $I = \frac{E}{R}$. By substituting

the equivalent $\frac{E}{R}$ for I in the formula, $W = EI$, we have $W = E \times \frac{E}{R} = \frac{E^2}{R}$;

that is, $W = \frac{E^2}{R}$, or we may say that the watts equals volts times volts

divided by resistance. Applying this to the problem, the volts $E = 375$,

and the resistance $R = 7.5$, then $W = \frac{E^2}{R} = \frac{375 \times 375}{7.5} = 18,750$; this is the

same as obtained by the other two methods.

The formula $W = EI$ may be transposed to read $E = \frac{W}{I}$ for obtaining

the volts when the watts and current is known; also $I = \frac{W}{E}$. From the

latter the current can be obtained when the watts and volts are given. Taking the value for $W = 18,750$, and $I = 50$, given in the problem, the

value of $E = \frac{W}{I} = \frac{18,750}{50} = 375$ volts, as given in the problem. Again, the

value of $I = \frac{W}{E} = \frac{18,750}{375} = 50$ amperes; this checks with the values given.

All these expressions are important and should be applied where possible to solving the study problems until the students have thoroughly familiarized themselves with them.

The load on a generator consists of fifty 25-watt, seventy five 60-watt incandescent lamps, five 6.5 ampere arc lamps and two motors, one

5 hp. and the other 10 hp. The motors take 18 and 30 amperes respectively on a 225-volt circuit. The voltage of the lamp circuit is 112.5 volts. Find the total load in watts, kilowatts and electrical horsepower. If the load is constant for 3.5 hours, how much should a kilowatt-hour meter register if connected in the circuit during this period?

The watts taken by the 25-watt lamps are equal to the number of lamps times their rating, or $50 \times 25 = 1,250$; the 60-watt lamps, $75 \times 60 = 4,500$ watts; the arc lamps, $5 \times 6.5 \times 112.5 = 3,656.25$ watts; the 5-hp. motor, $\text{volts} \times \text{amperes} = 225 \times 18 = 4,050$; and by the 10-hp. motor, $30 \times 225 = 6,750$ watts. The total watts, $W = 1,250 + 4,500 + 3,656.25 + 4,050 + 6,750 = 20,206.25$; total kilowatts, $KW = \frac{W}{1,000} = \frac{20,206.25}{1,000} = 20.2$; and

total electrical horsepower $= \frac{W}{746} = \frac{20,206.25}{746} = 27.1$. The kilowatt-hours equal the *kilowatts* \times *time in hours*, in this problem $20.2 \times 3.5 = 70.7$.

CHAPTER VI

COMPLEX CIRCUITS AND EFFECTS OF INTERNAL RESISTANCE

Circuits in Which Elements Are Grouped in Series and Parallel.—So far our studies have been confined to simple parallel and series circuits. Frequently, conditions arise in practice where complex circuits are involved; that is, circuits in which elements are grouped in both series and parallel.

For example, in Fig. 93, r_1 and r_2 are connected in parallel and the group is connected in series with R_2 . To find the combined resistance of such a group of elements, it is first necessary to find the joint resistance R_1 of the parallel connected group.

$$R_1 = \frac{1}{\frac{1}{r_1} + \frac{1}{r_2}} = \frac{1}{\frac{1}{9} + \frac{1}{7}} = \frac{1}{\frac{16}{63}} = \frac{63}{16} = 3.94 \text{ ohms.}$$

The total resistance $R = R_1 + R_2 = 3.94 + 4.56 = 8.5$ ohms. The total current $I = \frac{E}{R} = \frac{115.6}{8.5} = 13.6$ amperes. Knowing the current and the resistance, we can find the volts drop across each section. By Ohm's law, the volts drop across R_1 is $E_1 = R_1 I = 3.94 \times 13.6 = 53.584$ volts, and the volts drop across R_2 is $E_2 = R_2 I = 4.56 \times 13.6 = 62.016$ volts. Adding these results, the total volts $E = E_1 + E_2 = 53.584 + 62.016 = 115.6$ volts, the same as given in Figs. 93 and 94.

The total current, 13.6 amperes, flows through R_2 , but divides in section R_1 , part of it flowing through r_1 and part through r_2 . The value of the current in r_1 and r_2 may be determined by Ohm's law, since we know the resistance of each branch and the volts drop. The current flowing in r_1 is

$$i_1 = \frac{E_1}{r_1} = \frac{53.584}{9} = 5.954 \text{ amperes, and the current in } r_2 \text{ is } i_2 = \frac{E_1}{r_2} = \frac{53.584}{7} = 7.655 \text{ amperes.}$$

Adding these results, the total current $I = i_1 + i_2 = 5.954 + 7.655 = 13.609$ amperes against 13.6.

Internal Resistance.—A practical application of problem, Fig. 93, is given in Figs. 95 and 96. Fig. 95 shows two battery cells connected in series. Each cell has a normal voltage, $e=1.75$ volts and an internal resistance $r=0.5$ ohm. The two cells when connected in series will give a normal voltage $E = 1.75 + 1.75 = 3.50$ volts. When the cells are connected to an external circuit, the total pressure will not be effective in setting up a current because it will require part of the volts to cause the current to flow through the

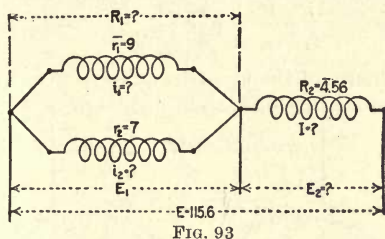

FIG. 93

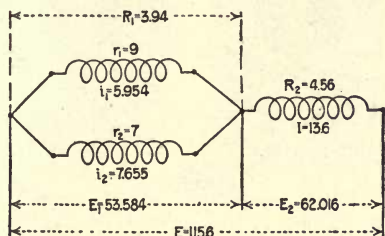

FIG. 94

FIGS. 93 and 94.—Two resistances connected in parallel and in series with a third element.

internal resistance of the cells. This condition is similar to that in all power machinery. For example, if in the cylinder of a steam engine there is developed 100 hp., all the 100 hp. will not be delivered at the flywheel. Part of the power developed in the cylinder will be used to overcome the opposition offered by the various parts of the engine itself. Likewise for a motor, if 6 hp. of electrical energy is supplied to a motor, it will not develop 6 hp. at its pulley, but only about 5 hp. This means approximately 1 hp. is required to

overcome the friction of the moving parts of the motor and other losses. The foregoing is just the condition we have in any source of electrical energy. That is, the total power produced in the device is not available at its terminal, as we shall see from a consideration of the latter circuit.

In Fig. 96 are shown the cells of Fig. 95 connected to an external circuit of two resistances in parallel. The joint resistance of the external circuit is

$$R_1 = \frac{1}{\frac{1}{r_1} + \frac{1}{r_2}} = \frac{1}{\frac{1}{5} + \frac{1}{3}} = \frac{15}{8} = 1.875 \text{ ohms.}$$

The internal resistance of the two cells in series is $R_2 = r + r = 0.5 + 0.5 = 1$ ohm, and the total resistance is $R = R_1 + R_2 = 1.875 + 1 = 2.875$ ohms.

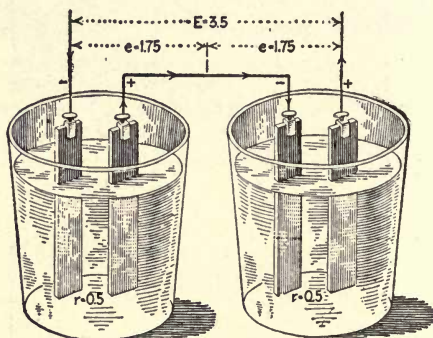

FIG. 95.—Two voltaic cells connected in series.

Tracing the circuit from the positive terminal in Fig. 96 through the resistances r_1 and r_2 back through the cells to the positive terminal, we have a condition similar to that given in Fig. 94; that is, two resistances connecting in parallel in series with a third element. However, we neglected the resistance of the source of electromotive force in Figs. 93 and 94 and considered the voltage constant at the terminals of the resistance, which is practically so in light and power circuits.

How to Compute Value of Current When Effect of Internal Resistance is Considered.—To find the current flowing in the circuit, the same method is used in Fig. 96 as in Fig. 94; namely, dividing the total volts

by the total resistance. The total pressure is $E=3.5$, the open-circuit volts of the battery, and the total resistance is $R=2.875$. Hence $I = \frac{E}{R} = \frac{3.5}{2.875} = 1.217$ amperes. To cause the current, $I=1.217$ amperes, to flow through the battery resistance, $R_2=1$ ohm, will require by Ohm's law a voltage, $E_2=R_2I=1+1.217=1.217$ volts. This will leave available a voltage E_1 at the terminals of the battery, which is equal to the total pressure, $E=3.5$, minus the volts used to cause the current to flow through the battery, or $E_1=E-E_2=3.5-1.217=2.283$ volts, as indicated in the

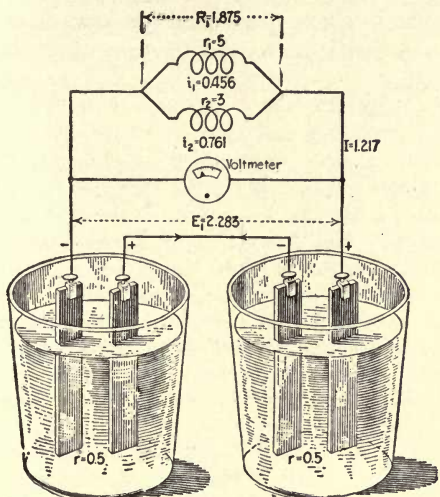

FIG. 96.—Two voltaic cells connected in series and to two resistances in parallel.

figure. By applying Ohm's law to the external circuit, the current flowing through the external circuit is $I = \frac{E_1}{R_1} = \frac{2.283}{1.875} = 1.217$ amperes, which is the same as obtained by the previous method. We may now find the current i_1 in r_1 and i_2 in r_2 . $i_1 = \frac{E_1}{r_1} = \frac{2.283}{5} = 0.456$ amperes; $i_2 = \frac{E_1}{r_2} = \frac{2.283}{3} = 0.761$ ampere; and $I = i_1 + i_2 = 0.456 + 0.761 = 1.217$ amperes.

Volts Drop in a Source of Electromotive Force.—The volts drop in a voltaic cell or any other source of electromotive force cannot be measured directly by a voltmeter, but must be calculated as in the foregoing. The volts drop may also be obtained by measuring the open-circuit voltage with

a voltmeter, which in Fig. 95 would be 3.5 volts, and then measuring the voltage with the load connected as in Fig. 96. This will give the pressure effective in causing current to flow through the load. In Fig. 96 the voltmeter should read 2.283, and the difference between these two readings gives the volts drop through the cells, or $3.5 - 2.283 = 1.217$ volts. This corresponds with the calculated value previously obtained.

One feature in these problems that stands out more prominent than any other is that it does not make any difference how the results are arrived at, when correct they will always satisfy Ohm's law.

A voltaic cell has a normal open-circuit voltage of 1.8 volts. Its internal resistance is 0.4 ohm. Find the current that this cell will cause to flow through the coil of a bell that has 2.6 ohms, also find the voltage.

In the foregoing it was shown that the normal open-circuit voltage of a battery cell was not the pressure that would exist when the battery was supplying current to an external circuit, and although the electrical pressure was produced in the cell, part of this pressure is used up in causing the current to flow through the source, owing to the internal resistance.

In the problem the cell in question has an internal resistance $r = 0.4$ ohm and a normal voltage E of 1.8 volts. Fig. 97 shows this cell con-

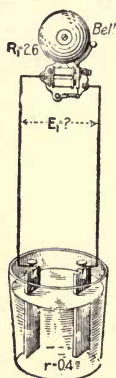

FIG. 97.—Bell connected to voltaic cell.

nected to a bell having a resistance R_1 of 2.6 ohms, as called for in the problem. The total resistance of the bell and the battery cells is

$R = R_1 + r = 2.6 + 0.4 = 3$ ohms, the current $I = \frac{E}{R} = \frac{1.8}{3} = 0.6$ ampere, and

the voltage across the bell terminals is $E_1 = R_1 I = 2.6 \times 0.6 = 1.56$ volts. The difference between this latter value and the open-circuit volts will give the volts e necessary to cause the current to flow through the battery; that is, $e = E - E_1 = 1.8 - 1.56 = 0.24$ volt. Or, by Ohm's law, $e = rI = 0.4 \times 0.6 = 0.24$ volt. Here we find that Ohm's law may be applied equally as well to finding the volts necessary to cause the current to flow through the internal resistance of the source of voltage as to the external circuit.

Volts Drop Through Resistance of Armature.—If the armature of a generator has 0.25 ohm resistance, what voltage must it produce to cause a current of 35 amperes to flow through 4.75 ohms? Find the value of the volts at the armature terminals when the current is flowing; the watt, kilowatt, electrical horsepower supplied to the load and the watt loss in the armature.

This problem is worked out similarly to the foregoing one, the values being given in Fig. 98. The total resistance R of the circuit is the sum

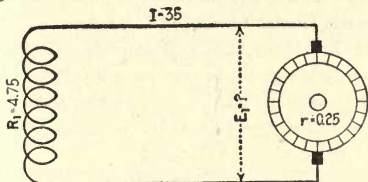

FIG. 98.—Diagram of generator and simple circuit.

of the resistance of the armature and the external circuit, or $R = r + R_1 = 0.25 + 4.75 = 5$ ohms. The voltage necessary to cause the current to flow through the total resistance, by Ohm's laws, is $E = RI = 5 \times 35 = 175$ volts. This total pressure is not all effective at the armature terminals, although 175 volts is what the voltmeter would read before the load is connected. A small portion of it is used to cause the current to flow through the armature. There are several ways that volts at the armature terminals may be calculated when the current is flowing. First, by Ohm's law, $E_1 = R_1 I = 4.75 \times 35 = 166.25$ volts. Second, the volts e necessary to cause the current to flow through the armature will be equal to the resistance of the armature times the current. This is found just the same as the volts necessary to cause the current to flow through the battery, Problem 1. In Fig. 98, $e = rI = 0.25 \times 35 = 8.75$ volts, and the difference between this and the total volts will give the volts effective at the terminals of the generator to cause the current to flow through the external circuit, or $E_1 = E - e = 175 - 8.75 = 166.25$ volts; this checks up with the values obtained by Ohm's law. The foregoing accounts for one of the causes why the voltage of a generator generally drops off slightly when load is applied; a small percentage of the total volts is used up to cause the current to flow through the armature.

The watts W_1 supplied to the load by the generator, are equal to the

available volts E_1 times the current I ; that is, $W_1 = E_1 I = 166.25 \times 35 = 5,818.75$; $\text{kilowatts} = \frac{W}{1,000} = \frac{5,818.75}{1,000} = 5.8$ kilowatts and *electrical horsepower* $= \frac{W}{746} = \frac{5,818.75}{746} = 7.8$ horsepower. The watts loss w in the armature is equal to the volts drop e through the armature times the current I , or $w = eI = 8.75 \times 35 = 306.251$ watts. Another method of obtaining the watts loss in the armature is $w = I^2 r = 35 \times 35 \times 0.25 = 306.25$ watts. This 306.25 watts represents energy that has been supplied to the machine which is expended within the machine itself and appears in the form of heat. The total watts developed in the armature is $W = EI = 175 \times 35 = 6,125$ watts, and the difference between this value and the watts supplied is also equal to the watts loss, or $w = W - W_1 = 6,125 - 5,818.75 = 306.25$ watts. From this it is seen that 6,125 watts are developed in the armature, but only 5,818.75 are available at the load, 306.25 watts are lost in the armature, as explained in the foregoing.

Effects of Increasing the Load on Batteries.—Referring to the problem Fig. 97, and connecting a second bell in parallel with the first, as in Fig. 99, we will find that the volts E_1 will be less in the latter than in the former. The joint resistance R_2 of the two bells in parallel will be one-half that of one, or $R_2 = \frac{R_1}{2} = \frac{2.6}{2} = 1.3$ ohms. This gives a total resistance R for the bells and battery of $R = R_2 + r = 1.3 + 0.4 = 1.7$ ohms. If the cell, Fig. 99, has an open-circuit voltage, $E = 1.8$ volts as in Fig. 97, the value of the current I will be $I = \frac{E}{R} = \frac{1.8}{1.7} = 1.06$ amperes, which will be divided

equally between the two bells in parallel, or $i = \frac{I}{2} = \frac{1.06}{2} = 0.53$ ampere, against 0.6 ampere flowing through the bells in Fig. 97.

The volts E_1 applied to the terminals of the bells are by Ohm's law, $E_1 = R_1 I = 1.3 \times 1.06 = 1.378$ volts, against 1.56 volts in Fig. 97. Also the volts drop through the battery is $e = rI = 0.4 \times 1.06 = 0.424$ volt. The sum of these two values is $E = E_1 + e = 1.378 + 0.424 = 1.802$ volts, against 1.8 volts given. The difference of 0.002 volt is due to the value 1.06 amperes for the current being a little large. This is why one bell may ring satisfactorily from a battery, but when two are connected in parallel they may not ring from the same source.

What we have seen in reference to Fig. 99 also accounts for the reason electric locomotives and trucks operated from storage batteries will sometimes pull more when the motors are connected in series than when they are grouped in parallel. For example, assume a condition where the resistance of the battery is 0.5 ohm, resistance of the wires connecting the battery to the motors 0.5 ohm, open-circuit volts of the battery is 110 and the current taken by the motors when in parallel

100 amperes, Fig. 100. The total resistance of the battery and connecting wires is $R = r_1 + r_1 + r = 0.25 + 0.25 + 0.5 = 1$ ohm, and the volts drop due to the resistance of the battery and connecting wires is $E_2 = RI = 1 \times 100 = 100$ volts drop; that is, 100 volts of the total 110 are used up to cause the current to flow through the resistance of the battery and the connecting wires, which will leave only 10 volts available at the motor terminals. The watts supplied to the motors are $W_1 = E_1 I = 10 \times 100 = 1,000$ watts, or 500 watts to each motor.

If the motors are connected in series, as in Fig. 101, only 50 amperes will have to flow in the line to have 50 amperes flowing through the motors. With 50 amperes flowing in the line, the volts drop due to battery and line resistance is $E_2 = RI = 1 \times 50 = 50$ volts. This leaves 60 volts available at the motor terminals when they are connected in series, and the watts supplied to the two motors in series is $W_1 = E_1 I = 60 \times 50 = 3,000$

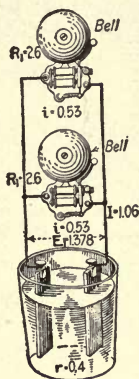

FIG. 99.—Voltaic cell connected to two bells in parallel.

watts. Hence it will be seen that three times the energy is supplied to the motors when they are connected in series as when connected in parallel. In the first case the total watts given up by the battery is equal to the total volts times the total current, or $W = EI = 110 \times 100 = 11,000$ watts, and in the second case $W = EI = 110 \times 50 = 5,500$ watts. This illustrates very clearly the necessity of keeping the resistance on the source of electromotive force and the connecting wires low if a large current is to be supplied. In the first case the battery gave up 11,000 watts, but only 1,000 watts were supplied to the motors, the other 10,000 watts being lost in the connected wires and the battery, owing to their resistance. In the second case the battery supplied a total of only 5,500 watts, but 3,000 watts, or three times that in Fig. 100, were supplied to the motors, only 2,500 watts being lost in the line and battery.

If the combined resistance of the line and battery had only been

0.5 ohm, in Fig. 100, the watts supplied to the motors in parallel would be 6,000, and with the motors in series, as in Fig. 101, 4,250. Here the conditions have been reversed; since the motors in parallel are supplied a greater wattage than when connected in series, they will do a greater work. It is, therefore, evident that the internal resistance of the source of electromotive force is an important factor and must be kept low if the voltage is to remain fairly constant; also the resistance of the connecting wires must be kept low if the voltage is to remain constant at the load. These elements have a direct bearing upon the size of conductors used to transmit a given current and will be treated subsequently.

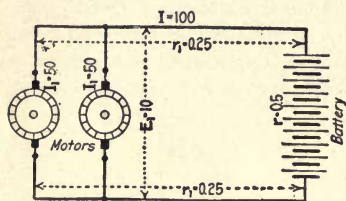

FIG. 100

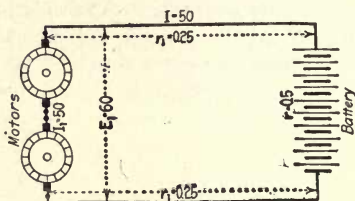

FIG. 101

FIG. 100.—Battery connected to two motors in parallel.

FIG. 101.—Battery connected to two motors in series.

In Fig. 102 the battery has a normal pressure between its terminals of 6 volts and an internal resistance R_1 of 0.3 ohm, which is connected to a dynamo that develops 10 volts across its terminals on open circuit. The resistance of the armature is $r = 0.2$ ohm. Neglecting the resistance of the connecting wires, find the current that will flow through the battery when connected to the generator, as shown in the figure; also the volts impressed on the battery terminals.

The combined resistance of the battery and armature will be $R = R_1 + r = 0.3 + 0.2 = 0.5$ ohm. The battery is so connected that its pressure will oppose that of the generator, consequently the voltage E effective in causing a current to flow through the circuit will be the difference between that of the dynamo and the battery, or $E = 10 - 6 = 4$ volts. Note that when two electromotive forces oppose each other, only the difference between them is effective, just the same as when two mechanical forces

oppose each other. The current flowing in the circuit will be $I = \frac{E}{R} = \frac{4}{0.5}$

$= 8$ amperes. Part of the 4 volts effective in causing the current to flow is used up by the resistance of the battery and part in the dynamo. The voltage required to cause the current to flow through the resistance of the battery equals $R_1 I = 0.3 \times 8 = 2.4$ volts, and this value plus the open-circuit voltage of the battery equals the volts, E_1 , impressed on its terminals, or $E_1 = 2.4 + 6 = 8.4$. The volts drop through the armature of the dynamo is $E_2 = rI = 0.2 \times 8 = 1.6$ volts.

In Fig. 103 determine the voltage E that the dynamo must develop to cause 30 amperes to flow in the circuit, the volts drop E_2 across the resistance R_2 , volts E_3 impressed on the battery terminals, watts lost (W_1) in the armature, watts (W_2) expended in the resistance R_2 , the watts (W_3) supplied to the battery, total watts, kilowatts and electrical horsepower.

The total resistance R in the circuit is the sum of the resistance of the armature R_1 , the external resistance R_2 and the battery resistance R_3 ; that is, $R = R_1 + R_2 + R_3 = 0.15 + 3.3 + 0.05 = 3.5$ ohms. The voltage E_2 that the dynamo will have to develop to cause a current I of 30 amperes to flow through the resistance R of 3.5 ohms, is $E_r = RI = 3.5 \times 30 = 105$ volts; 105 volts is what the dynamo would have to generate if resistance was the only opposition in the circuit, but in this case the battery has an open-circuit voltage of $E_b = 75$, which must also be overcome, therefore the dynamo will have to generate a total pressure of $E = E_r + E_b = 105 + 75 = 180$ volts. In the armature due to resistance there will be a voltage

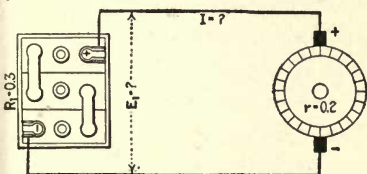

FIG. 102

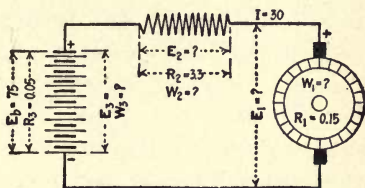

FIG. 103

FIG. 102.—Battery connected directly to a generator.

FIG. 103.—Resistance in series with a battery and generator.

drop of $E_a = R_1 I = 0.15 \times 30 = 4.5$, and the available volts at the armature terminals are $E_1 = E - E_a = 180 - 4.5 = 175.5$. The voltage necessary to overcome the ohmic resistance of the battery is $E' = R_3 I = 0.05 \times 30 = 1.5$, and the total voltage E_3 applied to the battery is the sum of that necessary to overcome the open-circuit volts and that to cause the current to flow through the internal resistance, or in this case, $E_3 = E_b + E' = 75 + 1.5 = 76.5$ volts. The volts drop across the resistance R_2 is $E_2 = R_2 I = 3.3 \times 30 = 99$. Then $E = E_a + E_2 + E_3 = 4.5 + 99 + 76.5 = 180$ volts, which checks with the total previously calculated.

The watts loss in the armature is $W_1 = E_a I = 4.5 \times 30 = 135$; watts expended in the resistance R_2 are $W_2 = E_2 I = 99 \times 30 = 2,970$; watts supplied to the battery are $W_3 = E_3 I = 76.5 \times 30 = 2,295$ watts, and the total watts $W = W_1 + W_2 + W_3 = 135 + 2,970 + 2,295 = 5,400$. W also equals $E I = 180 \times 30 = 5,400$ watts, which checks with the foregoing. The total kilowatts

$$= \frac{W}{1,000} = \frac{5,400}{1,000} = 5.4, \text{ and the electrical horsepower} = \frac{W}{746} = \frac{5,400}{746} = 7.2.$$

The foregoing calculations very clearly show the necessity of having the voltage of the circuit that a battery is to be charged from approximately the same as that of the battery if the charging is to be economically done. In this problem the pressure was 99 volts too high, consequently we had to put resistance enough in the circuit to use this pressure up, or 3.3 ohms. In the resistance R_2 , 2,970 watts were expended which did no useful work and therefore represent a direct loss that might have been saved by having the voltage of the dynamo approximately that required by the battery.

CHAPTER VII

ELECTRICAL INSTRUMENTS

Principles on Which Electrical Instruments Are Constructed.—So far attention has been called to three effects of an electric current—the magnetic effect, the heating effect and the electrochemical effect. Electrical measuring instruments are constructed on all three of these principles. However, most direct-current instruments, as constructed to-day employ only the magnetic effects of the current in conjunction with a permanent magnet; therefore in this discussion only electrical instruments constructed on this principle will be considered, leaving the instruments embodying the other principles for our studies of alternating current where they are mostly employed.

If a coil of wire is placed so that the plane of its turns point north and south, as in Fig. 104, when a compass is placed within the coil, the needle will take a position parallel to this axis, as shown. When an electric current is passed through the coil, it will cause a magnetic field to be set up about the turns of the coil, as explained in Chapter II. With the transverse axis of the coil pointing north and south, as in Fig. 104, the lines of force passing through the coil will be at right angles to the compass needle and will tend to swing the latter from its position parallel to the earth magnetic field. The result of this is shown in Fig. 105, where the needle is parallel to the lines of force, or turned 90 deg. from the position in Fig. 104. The amount that the needle will be turned from its natural position will depend upon the strength of the current and the number of turns in the coil. This scheme is one of the simplest and oldest used for

measuring electric current, or voltage, and is called a galvanometer.

The next step is to reverse the order of the elements in Fig. 104 and make the magnet stationary and the coil movable. Such an arrangement is given in Fig. 106, where a horseshoe magnet is shown with a small coil suspended between its poles, the plane of the turns of the coil being parallel to the magnetic field of the magnet. If an electric

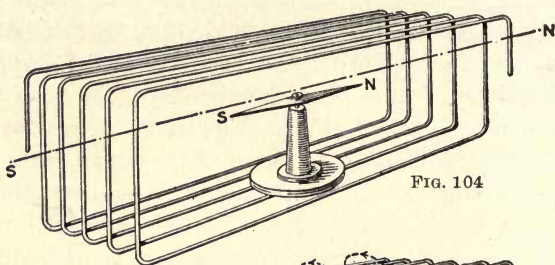

FIG. 104

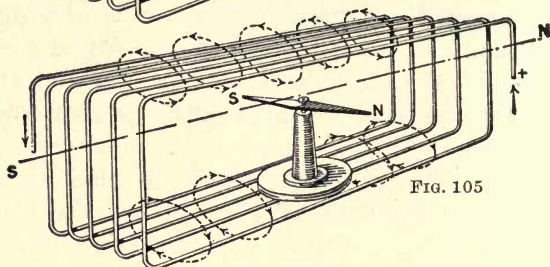
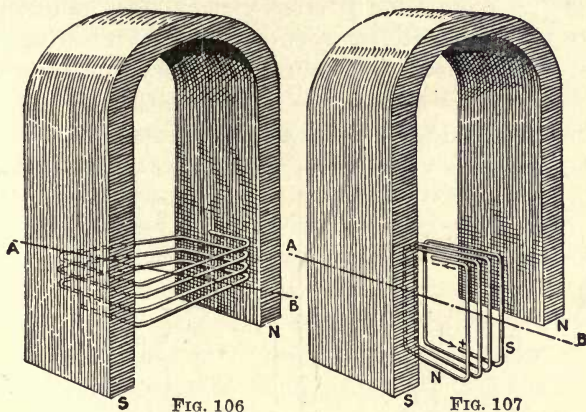

FIG. 105

FIGS. 104 and 105.—Illustrate principle of galvanometer.

current is caused to flow through the coil, a magnetic field will also be set up about it at right angles to the lines of force from the poles of the magnet, which will tend to cause the coils to revolve about the axis *AB* until the direction of its magnetic field is parallel to that of the magnet, as in Fig. 107. This is the arrangement used in most instruments for measuring a direct current or voltage, and is usually known as the *movable coil between the poles of a permanent magnet type*. It will be seen that the north pole of the coil points to the south pole of the magnet. If the direction of the current is reversed through the coil, it would turn in the

opposite direction, consequently instruments built on this principle can be used on circuits only in which the current always flows in one direction.



FIGS. 106 and 107.—Show principle of direct-current voltmeter and ammeter.

Movement for Modern-Type Instrument.—Fig. 108 shows a complete system of a modern-type instrument embodying the foregoing principle. To concentrate the lines of force of the magnet on the coil, soft-iron polepieces *I* are fastened to the pole faces of the magnet *M*, also a soft-iron core *C* is supported between the polepieces, leaving only sufficient clearance between the core and polepieces for the coil to revolve. The coil *A* is supported on pivot bearings and is opposed from turning by small spiral springs at the top and bottom of the coil; the top spring is shown at *F*. A pointer *P* made from a small aluminum tube is mounted on the coil so that when the coil moves it will be carried across the scale *S*. The scale *S* is supported from the magnet, therefore the entire system may be removed as a whole from the case for adjustment. It will be noticed that the right-hand terminal of the instrument is marked + (positive), and the left-hand terminal — (negative). This is standard practice on all instruments of this type. In this way the

instrument may be used to determine the polarity of a circuit.

The movable parts of such an instrument must be very light to reduce the friction element to a minimum, so as not to interfere with the accuracy of the indication. Consequently the coil must be wound with very fine wire, which means that it can carry only a very small current. The device shown in Fig. 108 may be used to measure either

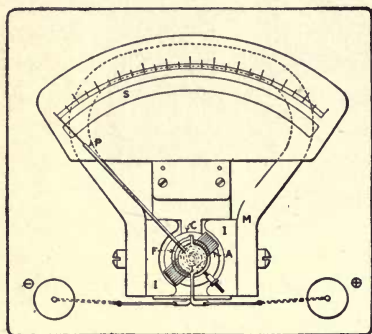

FIG. 108

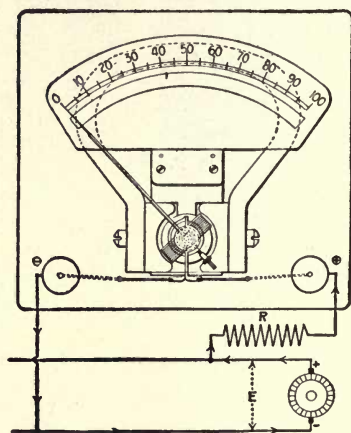

FIG. 109

FIG. 108.—Instrument for either voltmeter or ammeter.

FIG. 109.—Instrument, Fig. 108, connected as a voltmeter.

voltage or current, depending upon how it is connected in the circuit. If voltage, the coil is connected in series with a high resistance, and if current, in parallel with a low resistance.

Instrument Connected as Voltmeter.—It was pointed out in the foregoing that the movement used in a voltmeter or an ammeter is the same, the difference in the two instruments being in the way they are connected to the circuit. The movement is connected in series with a high resistance when used to measure volts and in parallel with a low resistance when used to measure current. It is general practice to use about 100 ohms resistance in series with the

movable coil of the voltmeter for each volt of scale range; that is, an instrument that would indicate 100 volts on full-scale reading will have approximately $100 \times 100 = 10,000$ ohms resistance, or an instrument that will indicate 150 volts on full-scale reading will have about $100 \times 150 = 15,000$ ohms resistance. This value will vary slightly with different instruments. Instruments that have approximately 100 ohms per volt scale reading are what may be termed the general commercial type of instrument used in general practice. However, there are types of voltmeters that have a very high resistance of 1,000,000 ohms. Such instruments are generally used for measuring high resistance such as the insulation resistance of electrical apparatus.

In Fig. 109 is shown an instrument system similar to that in Fig. 108, connected in series with a resistance R across the two conductors of a circuit. Assume that the resistance of the movable coil is 10 ohms and that a resistance R of 9,990 ohms is connected in series with this coil; then the total resistance of the instrument will be 10,000 ohms. If we mark the 0 position on the scale and then apply a voltage $E = 10$ across the instrument and resistance R in series, a current $I = \frac{E}{R} = \frac{10}{10,000} = 0.001$ ampere, will be set up through the coil. This current will create a turning effort against the spiral springs, which, let us assume, will cause the pointer to take the position indicated at 10. By marking this position and then increasing the voltage to 20, a current $I = \frac{E}{R} = \frac{20}{10,000} = 0.002$ ampere will be set up through the coil. This increased current through the coil will increase the turning effort and cause it to take a new position, say at the division marked 20 on the scale.

Turning Effort Proportional to the Current in the Coil.

—In this type of instrument the turning effort produced by the coil is directly proportional to the current flowing through it; that is, if the current in the coil is doubled the turning effort is doubled, consequently the distance that the

needle will move across the scale will be double. Owing to slight construction defects which are almost impossible to overcome, the foregoing is not absolutely true. If it were, all that would be necessary to do in dividing the scale, would be to determine the zero and maximum points and divide the distance between these two points into the desired number of divisions. However, on the better grade of instruments, to eliminate any slight errors that may occur, a number of cardinal points are determined by actual tests, such as the figures 0, 10, 20, 30, etc., up to 100. The scale is then removed, these divisions are divided, and the scale worked in by a draftsman. After this has been done and the scale replaced, the instrument may be used to measure volts on any direct-current circuit up to the limit of its scale.

In a large percentage of voltmeters the resistance is made up in a convenient form and placed inside the instrument case. In some portable types the resistance is made up separately and must be connected in series with the instrument when it is connected to the circuit.

Not Voltage That Causes the Coil to Move, but Current.

—If we had followed out our calculations for the current through the instrument at different 10-volt divisions, it would have been found to be 0.001, 0.002, 0.003, etc., up to 0.01 ampere for the 10-, 20-, 30-, up to the 100-volt division, respectively. Hence, we see it was not volts that actually caused the pointer to move, but the current that was made to flow through the coil by the voltage impressed upon it and the resistance. It does not make any difference how the current may be obtained through the coil, it will move the pointer to the position corresponding to the value of the current in the coil. For example, suppose that we remove the resistance R , as in Fig. 110, and connect the instrument to a circuit that has a voltage $E = 0.01$. Then the current through the coil, which has a resistance of only 10 ohms, will be $I = \frac{E}{R} = \frac{0.01}{10} = 0.001$ ampere. This value corresponds to that obtained in Fig. 109, with 10 volts and 10,000 ohms

resistance, consequently the pointer will throw to the same position in Fig. 110 for 0.01 volt as it did in Fig. 109 for 10 volts. In Fig. 109, when the instrument was connected to 100 volts, the current through the coil was $I = \frac{E}{R} = \frac{100}{10,000} = 0.01$ ampere. In Fig. 110 this value would be obtained when 0.1 volt was impressed on the instrument; that is, $I = \frac{E}{R} = \frac{0.1}{10} = 0.01$ ampere. In the former case the voltmeter would indicate that 100 volts was impressed across the circuit, where in the latter there is only 0.01 volt. Instru-

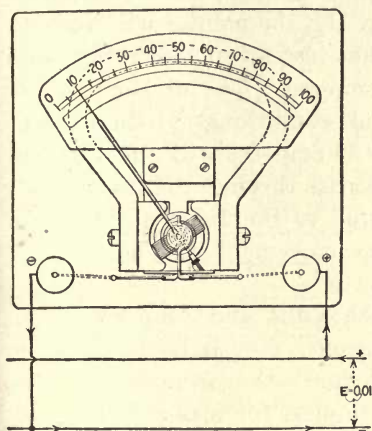

FIG. 110

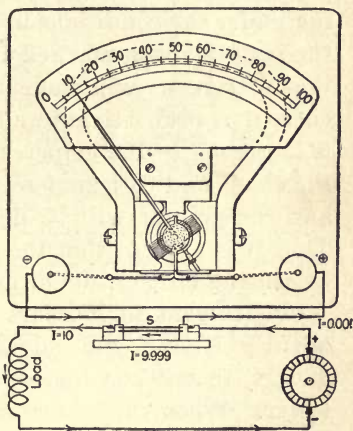

FIG. 111

FIG. 110.—Instrument, Fig. 108, connected as a millivoltmeter.

FIG. 111.—Instrument, Fig. 108, connected as an ammeter.

ments used to measure such low voltages or currents are called millivoltmeters or milliammeters, a millivolt being one thousandth of a volt, and a milliampere one thousandth of an ampere. Many of the instruments are constructed to read in the thousandth part of a volt or ampere.

Instrument Connected to Measure Current.—When we measure amperes, the instrument, as previously mentioned, is connected in parallel with a low resistance. Such a connection is shown in Fig. 111. The section of the circuit that the

resistance is connected across is called a shunt. The shunts are usually constructed of a special alloy called managnin, the resistance of which is practically constant through a wide range of temperature. If the shunt S , in Fig. 111 is made of such a resistance value that when 10 amperes is flowing through the circuit 9.999 amperes will flow through the shunt and 0.001 ampere passed through the instrument's coil, then the current value in the coil will be the same as when, in Fig. 109, the instrument was connected to a 10-volt circuit, which caused the needle to be deflected to the division marked 10. Consequently, if the instrument is operating under the conditions in Fig. 111, the pointer will move to the scale division marked 10, but instead of indicating volts the instrument will indicate amperes. The division of the current is proportional under all conditions. If the current is increased to 100 amperes, 99.99 amperes will flow through the shunt and 0.01 ampere will pass through the instrument, and the pointer will be deflected to the 100 scale division. Thus it is evident that the same movement may be used for measuring either volts or amperes.

Instrument to Measure Both Volts and Amperes.—Frequently it is found advantageous, especially in portable meters, to use one instrument for both voltmeter and ammeter. When the instrument is used for a double purpose, it generally has two or more sets of values, each being marked on the scale. In the case of a voltmeter, arranged for two or more scale ranges, it is equipped with different values of resistance connected to suitable terminals. In the ammeter, it is supplied with two or more shunts of different values. When the shunts are placed inside the instrument, which is usually done on small-sized meters, they are connected to suitable terminals on the instrument case, and if external shunts are used, as in large-capacity instruments, they are made up in suitable form to be carried around.

Where the two instruments are combined in one, the resistance and shunts may be located inside of small-range instruments. But in such practice the instrument must be

equipped with a key switch so as to shift from one service to the other. Fig. 112 shows such an instrument connected to read volts. If we assume the movable coil has 20 ohms resistance, and that a 4,980-ohm resistance R is connected in series with it, then the total resistance of the instrument is 5,000 ohms. If the instrument is connected to a 50-volt circuit as indicated in the figures, a current of

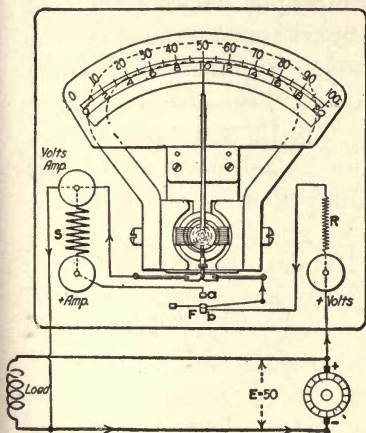

FIG. 112

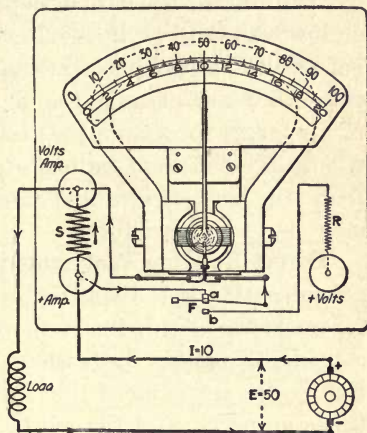

FIG. 113

FIG. 112.—Volt-ammeter connected to read volts.

FIG. 113.—Volt-ammeter connected to read amperes.

$$I = \frac{E}{R} = \frac{50}{5,000} = 0.01 \text{ ampere}$$
 will flow through the coil, which would cause it to move to division 50, as indicated.

On the other hand, if the instrument is connected in the circuit, as in Fig. 113, and the switch F pressed against the top contact a , the instrument's coil will be connected in parallel with the shunt S . If we assume the resistance value of the shunt to be such that when 9.09 amperes are passing through it, 0.01 ampere will flow through the coils—a total of 10 amperes in the circuit—then the needle will be deflected to the same scale division with 10 amperes flowing in the circuit as when connected to read volts in Fig. 112. However, in the latter case, the reading will be only 10 amperes;

this figure is given below on the scale. Therefore if the top of the scale is marked for volts and the bottom for amperes, the instrument may be used to indicate different values of volts and amperes, depending upon how it is connected in the circuits and the position of the switch *F*.

It is not necessary to have the two values marked on the scale; only one need be used and that multiplied or divided by 5 to obtain the other, depending upon whether the high or low values are given. Instruments that are used to read both volts and amperes are termed volt-ammeters. In some cases they are arranged so as to read three different values of amperes; for example, 0 to 1.5, 0 to 15, and 0 to 150, likewise three different values of volts, which may be different from the ampere values, depending upon what the instrument is to be used for.

Direct-Reading Wattmeter.—The next instrument for our consideration is the wattmeter. There are a great many different types of this instrument, but only two of them will be considered in this discussion—the direct-reading wattmeter, that is, the instrument that indicates the product of the volts times amperes, and the watt-hour meter. This latter device indicates the product of the volts, amperes and time in hours. This instrument is often incorrectly called a watt-meter.

In the wattmeter, instead of having a permanent horse-shoe magnet, as in the voltmeter and ammeter, to create a flux to act upon the movable coil, two coils *C* are used, which are connected in series in one side of the line, as shown in Fig. 114. The movable coil *V* is connected in series with a high resistance *R* and across the line, the same as the coil in Fig. 112, when the instrument was connected to read volts. Since the coils *C* are connected in series in the line, they will have a current flowing through them only when a current is passing through the circuit. Therefore it is only under this condition that a magnetic field will be produced to act upon the movable element and cause it to move. If there is no current flowing in the line, the instrument will not indicate, no difference what value the voltage across the coil

V may be. For example, the instrument connected as in the figure has 125 volts across the voltage coil, but since the line is open, no current is flowing in the current coil, therefore the instrument will not indicate. This is just as it should be, since watts is the product of volts times amperes. In Fig. 114 no current is flowing in the circuit, therefore the product of volts times amperes is zero.

If the circuit is closed, as in Fig. 115, and a current of 80 amperes flows as indicated, then coils C will have a magnetic field set up in them to react upon the field of the voltage coil

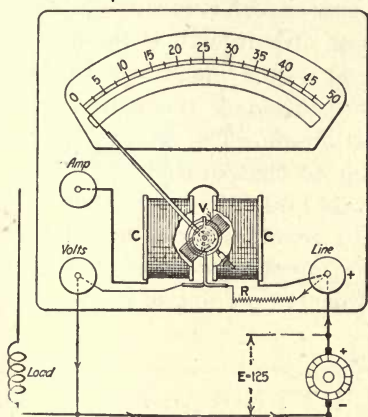

FIG. 114.

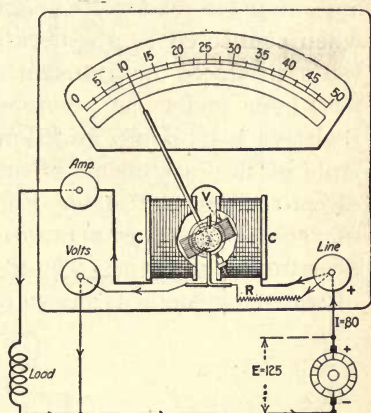

FIG. 115

FIGS. 114 and 115.—Direct-reading wattmeter connected in circuit.

and cause it to move the needle to a given position on the scale. In this case the product of the volts and amperes is $125 \times 80 = 10,000$ watts, or 10 kilowatts. If we mark the position of the needle on the scale 10, as in the figure, to indicate kilowatts then by taking other readings we can determine the different positions for various loads and work in the scale as explained for the voltmeter and ammeter in Figs. 108 to 111. The voltage of most direct-current circuits is practically constant, hence the strength of coil V will be practically constant. The current, however, varies as the resistance of the circuit, therefore the value of the lines of

force will vary in coils *C* and the coil *V* will be moved accordingly.

An instrument of this type is sometimes called an electro-dynamometer. The coils may be arranged so that it can be used to indicate volts and amperes, and this principle is one that is used in one type of voltmeter and ammeter for use on alternating-current circuits and will be given further consideration in our studies on this subject.

Watt-Hour Meter.—It will be seen that an instrument of the foregoing type reads watts direct just as the voltmeter and ammeter read volts or amperes direct respectively, and when connected to a generator or circuit, will indicate the watts produced or transmitted at every instance. In the watt-hour meter, as previously mentioned, the instrument registers watt-hours or kilowatt-hours. The general principle of the instrument is similar to that described for the direct-reading wattmeter, Figs. 114 and 115, except that the movable element is arranged to revolve the same as the armature of a motor. The general arrangement of one type of watt-hour meter is shown in Fig. 116. The two stationary

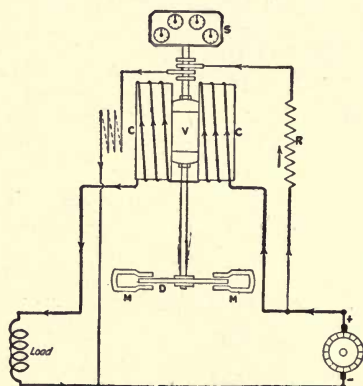

FIG. 116.—Diagram of watt-hour meter.

coils *C* are connected in series in the line, as in Figs. 114 and 115, and produce the magnetic field to act upon the current in the coils of the movable element *V*, which is constructed

the same as the armature of a direct-current motor, except that the winding is placed over a very light, nonmagnetic form instead of an iron core. The movable element is connected in series with a resistance R , and across the line, just as in Figs. 114 and 115. The top end of the shaft engages a registering system S , which is geared so that the pointers will indicate watt-hours or kilowatt-hours, depending upon the capacity of the meter. An enlarged view of the dials is shown in Fig. 117. Beginning at the right, the first dial is

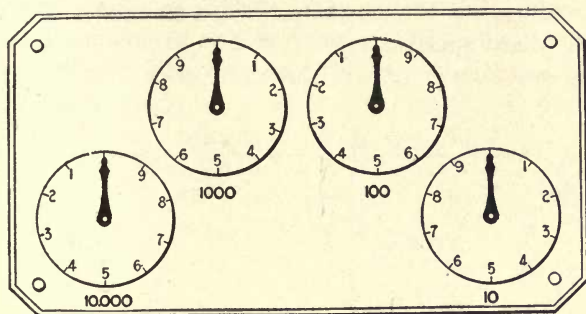

Fig. 117.—Dial for watt-hour meter.

marked 10, which indicates that one revolution of this pointer indicates 10 kilowatt-hours, or each division indicates 1 kilowatt-hour. The next dial is marked 100, which means that one revolution of this hand indicates 100 kilowatt-hours. The pointer on this dial moves one space for each revolution on the hand on scale marked 10. This system holds true for the other two dials.

In Fig. 116, when current is flowing through the current coils, the movable element will revolve at a speed proportional to the product of the current in coils C and the voltage impressed upon the voltage coil V . However, instead of the hand on any particular scale moving quickly to some division, as in Figs. 114 and 115, it will move very slowly and when the equivalent of one kilowatt for one hour has been transmitted in the circuit, the hand on the scale marked 10 will have moved one division. This equivalent of one kilo-

watt for one hour may be a constant load of one kilowatt for one hour, or a constant load of 6 kilowatts for 10 minutes—in fact, any combination of loads and time to produce this equivalent. In this way the number of kilowatt-hours used in a given time is registered.

A metal disk D is mounted near the bottom of the shaft and revolves between the poles of two horseshoe magnets M , and is used to adjust the meter. When the magnets are moved out towards the edge of the disk the meter will be slowed up, where moving the magnets toward the shaft will result in an increased speed.

CHAPTER VIII

METHODS OF MEASURING RESISTANCE

Voltmeter-and-Ammeter Method.—The electrical resistance of a device or circuit can be measured in several ways. One of the simplest, if the instruments are at hand, is to connect an ammeter and voltmeter in the circuit, as shown in Fig. 118, take a reading and then, by Ohm's law, calculate the resistance.

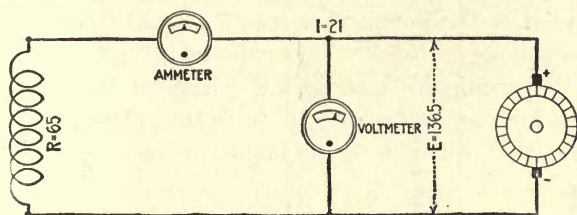

FIG. 118.—Voltmeter and ammeter connections for measuring resistance.

For example, if the voltmeter reads 136.5 and the ammeter 21, as in the figure, then the resistance of the circuit by Ohm's law is $R = \frac{E}{I} = \frac{136.5}{21} = 6.5$ ohms.

Known-Resistance Method.—A other method is to use a voltmeter and a resistance of known value, to determine the unknown resistance. In Fig. 119 is shown a known resistance $R = 15$ ohms connected in series with an unknown resistance R_1 , and these two connected to a 235-volt circuit. A voltmeter is used to measure the volts drop across the terminals of R and R_1 , as shown. Assume that the values obtained are as indicated: $e = 75$ and $e_1 = 160$. Since we know the voltage drop across the known resistance, the current is determined by Ohm's law, $I = \frac{e}{R} = \frac{75}{15} = 5$ amperes.

Then the unknown resistance $R_1 = \frac{e_1}{I} = \frac{160}{5} = 32$ ohms.

By substituting the values for $\frac{e}{e_1}$ and $\frac{R}{R_1}$ —that is, $\frac{75}{160}$ and $\frac{15}{32}$ respect-

ively—we have two equal fractions. Hence we may write the expression $\frac{e}{e_1} = \frac{R}{R_1}$. Written as a proportion, the formula becomes $e : e_1 :: R : R_1$, which indicates that the volts drop is proportional to the resistance. Therefore, to obtain any one of the values, provided the other three are known, is only a problem in simple proportion. Substituting the known values in the problem, Fig. 119, we have $75 : 15 :: 160 : R_1$, from which $R_1 = \frac{15 \times 160}{75} = 32$ ohms, as obtained by Ohm's law.

The foregoing is an important rule and should be remembered: *When a number of resistances are connected in series across a circuit, the voltage drop across each resistance is proportional to the resistance the voltage is measured across.* In Fig. 119, R_1 is 2.13 times as great as R ; likewise, the voltage marked e_1 the potential across R_1 , is 2.13 times as great as e , the voltage across R . This rule holds true under all conditions. In using this method the voltage of the circuit must not be so high as to destroy the resistance elements, and also of a value that will give a reasonable throw on the voltmeter.

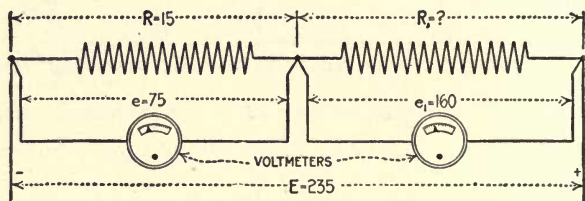

FIG. 119.—Measuring an unknown resistance with known resistance and voltmeter.

Measuring High Resistance.—For measuring very high resistances such as the insulation resistance of electrical machinery or circuits, a voltmeter is used not only to measure the drop of potential, but also as the known resistance. How this can be done will be understood by considering Figs. 120 and 121.

If we assume that the voltmeter, Fig. 120, has a total resistance R of 10,000 ohms and is connected to a 100-volt circuit, the current flowing through the instrument is $I = \frac{E}{R} = \frac{100}{10,000} = 0.01$ ampere. With this

current passing through the instrument, if properly calibrated, it should indicate 100. Connecting the instrument to a circuit of only 10 volts, the current flowing through it will be $I = \frac{E}{R} = \frac{10}{10,000} = 0.001$ ampere, and the needle will only be deflected to the 10-volt division.

Instead of connecting the voltmeter to a 10-volt circuit, suppose we connect it in series with 90,000 ohms resistance and to a 100-volt circuit, as in Fig. 121. The total resistance of the voltmeter circuit is $R_t = 90,000 + 10,000 = 100,000$ ohms. The current passing through the instrument is $I = \frac{E}{R_t} = \frac{100}{100,000} = 0.001$ ampere. This is the same value that was obtained when the instrument was connected directly to a 10-volt circuit. Conse-

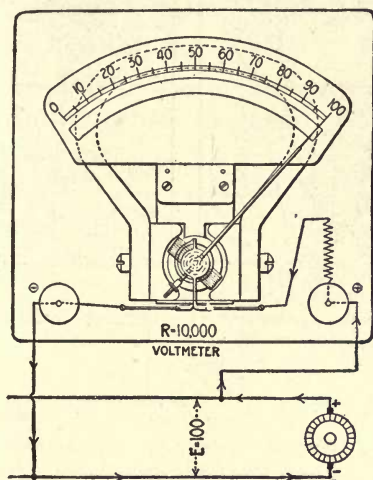

FIG. 120.—Voltmeter connected to circuit.

quently, in Fig. 121, the voltmeter will read 10 volts, the same as on a 10-volt circuit.

Suppose we did not know the value of R_1 , but knew the resistance of the voltmeter, which in this case we have assumed to be $R = 10,000$ ohms. If when the voltmeter is connected across the line as in Fig. 120, it indicates $E = 100$, and when connected as in Fig. 121, it indicates $e = 10$, then we have the conditions as shown in Fig. 122. Since there is only 10-volts' drop across the voltmeter, the remainder of the line volts e_1 must be expended across the unknown resistance R_1 ; that is, $e_1 = E - e = 100 - 10 = 90$ volts.

Comparing Fig. 122 with Fig. 119, it is evident that the same conditions exist in both cases; therefore, the proportion that is true in one

is also true in the other, which is: $e : e_1 :: R : R_1$, from which $R_1 = \frac{e_1 R}{e}$
 $= \frac{90 \times 10,000}{10} = 90,000$ ohms.

Hence it is evident that the voltmeter can be used as the known resistance to determine the value of an unknown resistance as well as measure the voltage drop, and is done when a voltmeter is used to measure a high resistance.

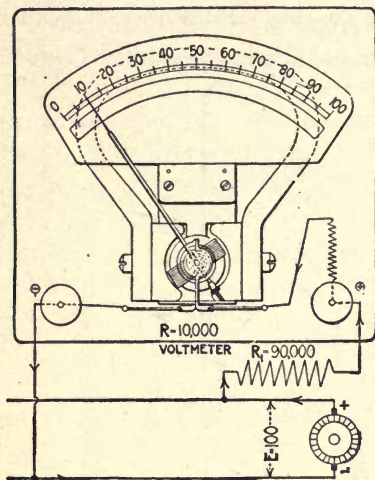

FIG. 121

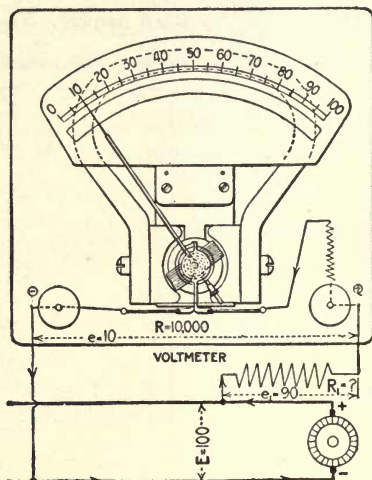

FIG. 122

FIGS. 121 and 122.—Show how an unknown resistance may be measured with a voltmeter.

Measuring Insulation Resistance.—Frequently it is necessary to determine the insulation resistance of electrical apparatus—for example, the insulation resistance of an armature. This measurement is made the same as explained in Fig. 122.

First connect the voltmeter across the line and determine the voltage E , then connect the voltmeter in series in one side of the line and to the commutator, with the armature shaft connected to the other side of the line, as shown in Fig. 123. Assume that the readings were found as in the figure; namely, the line volts $E = 225$, and when the voltmeter is connected in series with the insulation of the armature, as shown, it

indicates $e = 3.5$ volts. The volts drop across the armature insulation is $e_1 = E - e = 225 - 3.5 = 221.5$ volts. Knowing the resistance of the voltmeter to be $R = 25,000$ ohms, $R_1 = \frac{e_1 R}{e} = \frac{221.5 \times 25,000}{3.5} = 1,582,143$ ohms.

The idea is frequently harbored that if a circuit is insulated no current flows between the conductors. This would be true if we had a perfect insulator. Since no known perfect insulator is obtainable, it is therefore impossible to insulate a circuit so that there is not at least a very small current flowing from one conductor to the other. In Fig. 123 the winding is insulated from the armature core; nevertheless, a current $I = \frac{E}{R + R_1} = \frac{225}{1,607,143} = 0.00014$ ampere will be passing through the insulation under the conditions shown.

The insulation resistance of a generator or motor should be at least one million ohms. Frequently when the ordinary

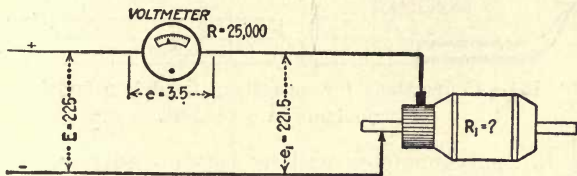

FIG. 123.—Connections for measuring armature-insulation resistance with voltmeter.

commercial voltmeter is connected as in Fig. 123, the insulation resistance is so high that the instrument will not give any indication. This would indicate that the insulation was above the prescribed standard.

Fig. 124 shows the connection for measuring the insulation resistance of a wiring system. Find the insulation resistance of the conductors from the values given.

In this problem $e_1 = E - e = 235 - 2.25 = 232.75$ volts and the insulation resistance $R_1 = \frac{e_1 R}{e} = \frac{31,500 \times 232.75}{2.25} = 3,258,500$ ohms.

The Wheatstone Bridge.—A piece of apparatus frequently employed for measuring electrical resistance is the Wheatstone bridge. This device is generally used to measure resistances above two or three ohms. The Wheatstone

bridge consists of three known resistances R_1 , R_2 , and R_3 , Fig. 125, arranged so that their values can be varied by removing different plugs. A galvanometer G and a battery B are connected as shown. The bridge is closed by the unknown resistance R , which is to be determined.

In measuring a resistance with the Wheatstone bridge the three arms R_3 , R_2 , and R_1 are so adjusted that points C and D , which the galvanometer connects to, are at the same potential. Under such a condition no current will flow through the galvanometer; consequently no deflection of the needle will be obtained—the bridge is then said to be balanced. How a condition like the foregoing can exist where no current will flow

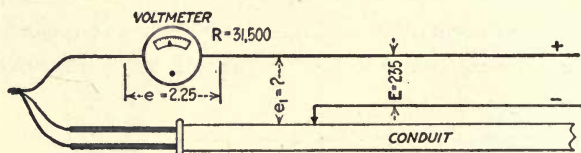

FIG. 124.—Connections for measuring insulation resistance of conductors in a conduit.

through the galvanometer will be better understood by considering Figs. 126 and 127. In Fig. 126 the galvanometer G is connected to the terminals of resistance R_3 . The current will now flow through the galvanometer in the direction indicated by the arrowheads. If the galvanometer is connected to the terminals of resistance R_2 , as in Fig. 127, the current will flow through the instrument in the opposite direction. In moving the galvanometer terminal from B to A the direction of the current has been reversed. Instead of transferring the galvanometer terminal directly from B to A , if the lead is connected into different points in resistances R_1 and R a location will be found where no current will flow through the galvanometer; this will be the point beyond which the current changes from one direction to another. At this point the voltage will be zero between the terminals of the galvanometer.

Hydraulic Analogy of a Wheatstone Bridge.—A hydraulic analogy of this condition is given in Fig. 129. Assume the two pipes 1 and 2 have a fluid flowing through them under pressure and that they are connected

at the points *A* and *B* by small pipes. At *A* the pressure is shown to be 50 lb. in each at the points where the pipes are connected. Since the pressure is the same at these points, no fluid will flow from one pipe to the other. However, at connection *B* the pressure in pipe 1 is 45 lb.,

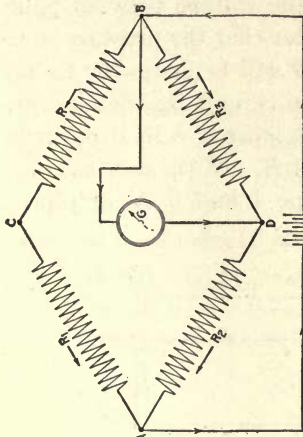

FIG. 126

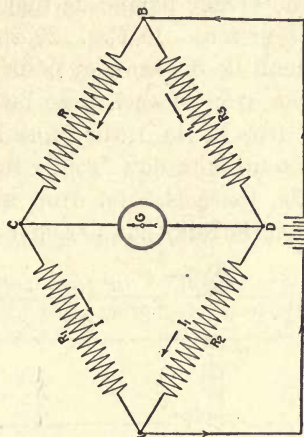

FIG. 128

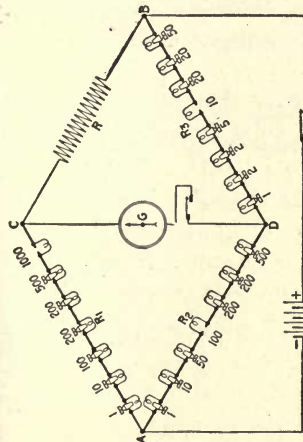

FIG. 125

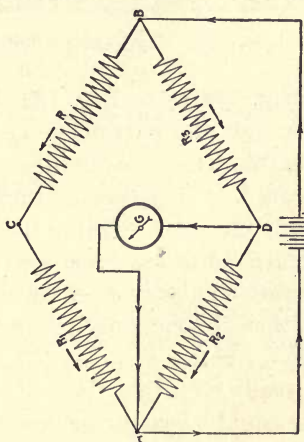

FIG. 127

Figs. 125 to 128.—Schematic diagrams of the Wheatstone bridge.

and in pipe 2 it is 44 lb. Since the pressure is 1 lb. higher in 1 than it is in 2, a flow will take place from 1 to 2, as indicated by the arrow. This is just the condition that we have in a Wheatstone bridge when it is balanced; the points to which the galvanometer connects are at the same pressure and no current flows through the instrument. If the bridge is not balanced, the points to which the galvanometer connects

are at a different potential and a current is caused to flow through the instrument, which will be indicated by the needle being deflected.

Condition to Give Balanced Pressure.—In Fig. 128 consider the bridge balanced; that is, the voltage between points *C* and *D* at zero. In Fig. 129, in order that the pressure in the pipes shall be the same at point *B* it will be necessary to have the same drop in each pipe between *A* and *B*; that is, there is 5 lb. drop in No. 1, therefore there must be 5 lb. drop in No. 2 if no fluid is to flow from 1 to 2 at *B*. In the case shown in Fig. 129, there is 5 lb. drop in pipe 1 and 6 lb. in pipe 2; consequently fluid flows from 1 to 2.

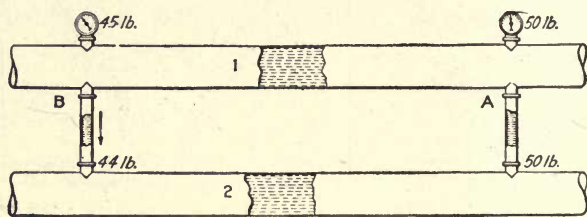

FIG. 129.—Hydraulic analogy of balanced pressure.

In Fig. 128 as in Fig. 129, in order that no current shall flow through the galvanometer the volts drop from *B* to *C* must be equal to the volts drop from *B* to *D*. Therefore, the drop from *C* to *A* will equal that from *D* to *A*. The volts drop across any circuit is equal to the current, in amperes flowing in the circuit, times the resistance of the circuit. If we indicate the current in the two branches of the bridge, Fig. 128, by *I* and *I*₁, then the volts drop from *B* to *C* is equal to *RI*; from *B* to *D*, *R*₃*I*₁; across *C* to *A*, *R*₁*I*; and from *D* to *A*, *R*₂*I*₁. We have already seen that the volts drop from *B* to *C* and *B* to *D* must be equal when the bridge is balanced; hence,

$$RI = R_3I_1 \quad (1)$$

Also the volts drop from *C* to *A* and that from *D* to *A* are equal; therefore,

$$R_1I = R_2I_1 \quad (2)$$

Before we go any farther with equations (1) and (2), let us consider a simple arithmetical expression that will help to show the reason for the final process in deriving the fundamental equation for the Wheatstone bridge. To illustrate:

$$3 \times 20 = 4 \times 15, \quad (1)$$

and

$$3 \times 12 = 4 \times 9. \quad (2)$$

Now if expression (1) is divided by (2), we have

$$\frac{3 \times 20}{3 \times 12} = \frac{4 \times 15}{4 \times 9}.$$

In this case the 3's and 4's cancel out and leave $\frac{20}{12} = \frac{15}{9}$, which in either case equals 1.66. Likewise, two equations may be divided one by the other to combine them into one. Dividing equation (1) by equation (2), for the Wheatstone bridge, we have

$$\frac{RI}{R_2I} = \frac{R_3I_1}{R_2I_1}.$$

I and I_1 cancel out of each side of the equation and the expression becomes

$$\frac{R}{R_1} = \frac{R_3}{R_2}.$$

Since R_1 , R_2 and R_3 are known, being obtained from the bridge, Fig. 125, R may be found from the equation

$$R = \frac{R_1 R_3}{R_2} = \frac{1,000 \times 10}{100} = 100 \text{ ohms.}$$

The correctness of the formula may be proved as follows: Assume the voltage of the battery to be $E = 5.5$ volts. The resistance of path BCA through the bridge, Fig. 125, is $R + R_1 = 100 + 1,000 = 1,100$ ohms; and the resistance of path BDA is $R_3 + R_2 = 10 + 100 = 110$ ohms. The current flowing through path BCA is

$$I = \frac{E}{R + R_1} = \frac{5.5}{1,100} = 0.005 \text{ ampere,}$$

and through path BDA is

$$I_1 = \frac{E}{R_3 + R_2} = \frac{5.5}{110} = 0.05 \text{ ampere.}$$

Then the volts drop across R equals $RI = 100 \times 0.005 = 0.5$ volt, and across R_3 equals $R_3 I_1 = 10 \times 0.05 = 0.5$ volt. Hence it is seen that the volts

drop from point *B* to *C* and the volts drop from *B* to *D* are equal. This conforms with the conclusion previously arrived at—when the bridge is balanced, $RI = R_3I_1$.

In measuring a resistance after an adjustment of the bridge has been made, close the battery key and then the galvanometer. Then if care is used in closing the galvanometer key, any heavy swings of the needle may be avoided if the adjustment of the bridge arms has thrown it considerably out of balance. See that the plugs are clean and do not handle them when oil or acid is on the hands.

When measuring a resistance, some idea can generally be gained as to what the approximate value is; adjust the bridge to this value and close the battery and then the galvanometer key. If this is too low, try a higher value; if this is too great, try a value between the two, until the bridge is approximately balanced. It is generally not possible to get an exact balance, but two values can be obtained, one giving a slight deflection of the needle in one direction and the other causing the needle to move slightly in the opposite direction, between the two deflections the correct value lies, which can be determined very closely.

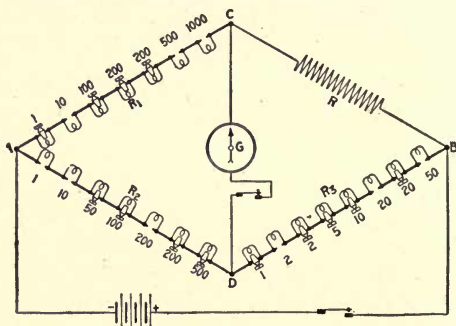

FIG. 130.—Wheatstone bridge diagram.

In Fig. 130 if the Wheatstone bridge is balanced under the conditions shown, find the value of the unknown resistance *R*.

$$\text{The value of } R = \frac{R_3 R_1}{R_2} = \frac{72 \times 1,510}{211} = 515 \text{ ohms.}$$

CHAPTER IX

CALCULATING SIZE OF CONDUCTORS

Wire Gage for Round Wire.—The gage chiefly used in this country for measuring copper conductors is known as the Brown & Sharpe (B. & S.) or American wire gage (A. W. G.) as it is sometimes called. This gage expresses the size of large conductors in their circular-mil cross-sectional area, and the small-sized wires by numbers. Standard wire sizes by numbers run from No. 40 to No. 0000; any conductor larger than No. 0000 is expressed in circular-mil cross-section as shown in the accompanying table. A circular-mil is the equivalent of the area of a circle one thousandth of an inch (0.001 in.) in diameter. On account of the small cross-section of a number of the wire sizes, this small unit becomes very convenient. For example, a No. 40 wire, the smallest standard size, is only 3.145 cir.mils in cross-sectional area. Expressed in square inches the area is 0.0000077634, which at once makes apparent the advantage of using the circular mil as a unit of measurement.

Circular Mil as a Unit of Measurement.—By using the circular mil as the unit of measurement for the cross-sectional area of round wires, the area in circular mils is equal to the diameter in mils squared, or the diameter in mils is equal to the square root of the cross-sectional area in circular mils. This is evident from the following: The formula for the area of a circle in square measure is $Area = Diameter^2 \times 0.7854$. If the diameter is expressed in mils, the area will be in square mils. One circular mil is equal to 0.7854 part of a square mil. Hence to reduce square mils to circular mils, divide the former by 0.7854, from which

$$\begin{aligned} \text{Area in circular mils} &= \frac{\text{area in square mils}}{0.7854} \\ &= \frac{\text{diameter}^2 \times 0.7854}{0.7854} = \text{diameter}^2 \end{aligned}$$

Some Features of the Wire Table.—The accompanying table gives various data on conductors used for light and power installations. This table covers only wire sizes down to No. 18, as smaller sizes than this are never used for light and power circuits. In fact no smaller than No. 14 is used for the circuits running to the various equipment, Nos. 16 and 18 being used only for the wiring of lighting fixtures, etc. The largest-sized conductor given is 2,000,000 cir.mils in cross-sectional area. Although this is not the largest conductor made, it may be considered to be the largest standard size, all sizes larger than this being special.

Down in the column headed "Diameter in Mils" is 500.0, and opposite this value in the left-hand column headed "Area in Circular Mils" the value 250,000 is given. This latter value is obtained by squaring 500, or $500 \times 500 = 250,000$. This is true of all the values in the column, "Area in Circular Mils"—they are equal to the values opposite, squared, in the column headed "Diameter in Mils." As another example, $866 \times 866 = 749,956$, or approximately 750,000; 750,000 and 866 are found in opposite columns, "Area in Circular Mils" and "Diameter in Mils" respectively.

Wire-Number Sizes.—Considering the wire-number sizes, it will be seen that the cross-sectional area is doubled or halved for every three numbers, depending on whether the sizes are increasing or decreasing. For example, a No. 5 wire is 33,100 cir.mils cross-sectional area; taking three sizes higher, a No. 2, it will be found to have a cross-sectional area of 66,370 cir.mils; $33,100 \times 2 = 66,200$; therefore a No. 2 wire is approximately twice as large in cross-section as a No. 5. This will be found to be the case all through the table. A No. 10 wire is approximately 10,000 cir.mils in

TABLE 1.—COPPER-WIRE TABLE OF SIZES, CARRYING CAPACITIES, WEIGHT, RESISTANCE, ETC.

B. & S. Gage No.	Area in Circular Mills = (Dia. in Mills.) ²	Diameter in Mills = $\sqrt{C.M.}$	Allowable Carrying Capacities of Wires.			Ohms per 1000 Ft. at 68° F.	Weight per 1000 Ft. Bare.	Copper Stranded Cable.		
			Rubber Covered.	Varnished Cloth.	Other Insulations.			Wires.		Outside Dia. Bare.
								No.	Dia. in Mills.	
.....	2,000,000	1414	1050	1260	1670	0.0052	6100	127	125.5	1.632
.....	1,900,000	1378	1010	1210	1610	0.0055	5796	127	122.3	1.590
.....	1,800,000	1342	970	1160	1550	0.0058	5490	127	119.1	1.548
.....	1,700,000	1304	930	1120	1490	0.0062	5186	91	136.7	1.504
.....	1,600,000	1265	890	1070	1430	0.0065	4880	91	132.6	1.459
.....	1,500,000	1225	850	1020	1360	0.0070	4576	91	128.4	1.412
.....	1,400,000	1183	810	970	1290	0.0075	4270	91	124.0	1.364
.....	1,300,000	1140	770	920	1220	0.0084	3963	91	119.5	1.315
.....	1,200,000	1095	730	880	1150	0.0088	3660	61	140.3	1.263
.....	1,100,000	1048	690	830	1080	0.0095	3356	61	134.3	1.209
.....	1,000,000	1000	650	780	1000	0.0105	3050	61	128.0	1.152
.....	950,000	974.7	625	750	960	0.0111	2898	61	124.7	1.122
.....	900,000	948.7	600	720	920	0.0117	2745	61	121.4	1.093
.....	850,000	922.0	575	690	880	0.0124	2593	61	118.0	1.062
.....	800,000	894.4	550	660	840	0.0131	2440	61	114.5	1.031
.....	750,000	866.0	525	630	800	0.0140	2288	61	110.8	0.997
.....	700,000	836.7	500	600	760	0.0150	2135	61	107.1	0.964
.....	650,000	806.2	475	570	720	0.0168	1983	61	103.2	0.929
.....	600,000	774.6	450	540	680	0.0175	1830	61	99.1	0.892
.....	550,000	741.6	425	510	640	0.0191	1678	61	94.9	0.854
.....	500,000	707.1	400	480	600	0.0210	1525	61	90.5	0.815
.....	450,000	670.8	365	435	550	0.0234	1373	37	110.3	0.772
.....	400,000	632.5	325	390	500	0.0263	1220	37	103.9	0.727
.....	350,000	591.6	300	360	450	0.0300	1068	37	97.2	0.680
.....	300,000	547.7	275	330	400	0.0350	915	37	90.0	0.630
.....	250,000	500.0	240	300	350	0.0420	762	37	82.1	0.575
0000	211,600	460.0	225	270	325	0.0497	645	19	105.5	0.528
000	167,800	409.6	175	210	275	0.0625	513	19	94.1	0.471
00	133,100	364.8	150	180	225	0.0789	406	19	83.7	0.419
0	105,500	324.9	125	150	200	0.0995	322	19	74.6	0.373
1	83,690	289.3	100	120	150	0.1258	255	19	66.3	0.332
2	66,370	257.6	90	110	125	0.1579	203	7	97.5	0.293
3	52,630	229.4	80	95	100	0.2004	160	7	86.6	0.260
4	41,740	204.3	70	85	90	0.2525	127	7	77.1	0.231
5	33,100	181.9	55	65	80	0.3130	100	7	68.8	0.206
6	26,250	162.0	50	60	70	0.394	79.46	7	61.2	0.184
8	16,510	128.5	35	40	50	0.641	49.98	7	48.4	0.145
10	10,380	101.9	25	30	30	1.010	31.43	7	38.6	0.116
12	6,530	80.8	20	25	25	1.601	19.77	7	30.6	0.092
14	4,107	64.1	15	18	20	2.565	12.43	7	24.2	0.073
16	2,583	50.8	6	10	4	4.040	7.82	7	19.3	0.058
18	1,624	40.3	3	5	3	6.567	4.92	7	15.1	0.045

cross-section area; counting down six sizes to No. 16, it is found that the area of this conductor is 2583 cir.mils, or approximately one-quarter the size of a No. 10. By remembering that the cross-sectional area of a No. 10 wire is approximately 10,000 cir.mils and that the wire sizes double every three sizes, an approximate wire table may be worked out.

Cross-Sectional and Diameter of Round Conductors.—

The reader should not confuse the cross-sectional area of a round conductor with the diameter. Although the cross-sectional areas of round conductors double every three sizes, the diameters double only every six sizes. This is as it should be, since doubling the diameter of a circle does not increase the area by two but by four times; or in other words, the area of a circle increases as the square of the diameter.

In the sixth column from the left-hand side of the table is given the resistance per 1000 ft. for round copper conductors at a temperature of 68 deg. F. Referring to the No. 5 wire, it will be found to have a resistance of 0.313 ohm per 1,000 ft., and No. 2, which is three sizes larger, has a resistance of 0.1579 ohm, or approximately one-half that of a No. 5. That is just as it should be, since the cross-sectional area is doubled, which is the same as connecting two equal resistances in parallel. In this case also we must be careful to discriminate between the cross-sectional area and the diameter of the conductor. If the cross-sectional area is doubled, the resistance for a given length is halved, but if the diameter is doubled, such as increasing from a No. 5 to a No. 00, the diameter of the former being 181.9 mils and that of the latter 364.8 mils or approximately double, the resistance will be decreased by 4. The resistance per 1,000 ft. of No. 5 copper wire is 0.313 ohm and that of No. 00 is 0.789, or approximately one-quarter that of the former. This again is as it should be; since the cross-section is increased by four, the resistance should decrease by four, just the same as when four equal resistances are connected in parallel, the

joint resistance of the four when connected in parallel is equal to that of one divided by four.

Wire Table Worked Out from No. 10.—Referring again to the No. 10 wire, it will be seen to have a resistance of approximately one ohm per 1,000 ft. Remembering that the cross-sectional area doubles or halves every three sizes and that the resistance for a given length varies as the cross-sectional area, an approximate table of the resistance per 1,000 ft. of round copper can be worked out. The same is true of the weight. No. 10 bare copper weighs 31.43 lb. per 1,000 ft.; No. 4, which is six numbers above No. 10, has approximately four times the cross-sectional area and weighs four times as much, or 127 lbs. per 1,000 feet.

Where wires are pulled into conduits, they are usually stranded except in small sizes, and even then it is good practice to use stranded conductors as they are less liable to be broken and cause trouble after they are installed. The three right-hand columns in the table give number of strands used to make up the conductor, the diameter of each strand and the outside diameter of the conductor bare. It will be seen that the diameter of a stranded conductor is somewhat greater than that of a solid wire of the same cross-sectional area. For example, the outside diameter of a 250,000-cir.mil solid conductor is 500 mils, as given in the third column from the right, while the outside diameter of the same conductor stranded is 575 mils. This is due to the space between the strands.

A solid conductor can be measured with a wire gage, but not so with a stranded conductor. The size of the latter may, however, be determined by measuring the diameter of one strand in mils with a micrometer and squaring this diameter and multiplying the product by the number of strands. For example, a No. 2 conductor is made up of 7 strands 97.5 mils diameter. The square of the diameter is $97.5 \times 97.5 = 9,506.25$ cir.mils. The conductor is made up of 7 strands, then the total cross-sectional area is $9,506.25 \times 7 = 66,544$ cir.-mils, against 66,370 cir.mils given in the table for a No. 2 conductor.

Allowable Carrying Capacities of Copper Wire.—The three columns under the heading “Allowable Carrying Capacities of Wires,” gives the allowable load in amperes that may be placed upon a copper conductor with a rubber insulation on the wire covered with one, two or three cotton braids, also for copper wires covered with layers of varnished cotton cloth, and this insulation provided with coverings as specified for rubber-covered wire, and also for conductors that have a weather-proof or a fire-proof insulation such as asbestos. These carrying capacities have been established by the National Fire Protective Association, and are based upon the current that the conductor will carry indefinitely without increasing in temperature to where it will cause the insulation to deteriorate, and no conductors should be loaded beyond this point. For further information on this table and the National Electric Code, the reader is referred to Mr. Terrell Croft’s book “Wiring for Light and Power,” published by the McGraw-Hill Book Co. This book deals exclusively with the application of the National Board of Fire Underwriters’ Regulations.

The carrying capacities given in the table work out all right for short distances, but when an attempt is made to load the conductors up to these capacities for distances over 500 ft., it will be found that in many cases the volts drop becomes excessive. Therefore, it becomes necessary to base the size of the conductors on an allowable voltage drop and not the allowable capacities established by the National Fire Protective Association. Of course a conductor so calculated must be at least as large for a given current as given in the table; if not, the size given in the table must be used.

Allowable Voltage Drop.—Just what the allowable voltage drop is, is a question that is determined by conditions. For a lighting circuit it should not be more than about 3 volts and for motor work in general not in excess of 5 per cent of the line voltage, although there are cases on record where the drop in the feeders has been as high as 25 per cent. This last value would under no condition be con-

sidered good practice. In long, high-voltage transmission lines the allowable drop varies from 5 to 10 per cent, 7.5 per cent being considered a good average.

Economical Size of Conductors.—The question as to just what is the most economical size of conductor may appear at first thought easy of determination. This, however, has proved to be one of the problems that no general rule can be evolved for. However, one thing may be said about it: As long as the returns on the power saved will pay the cost of the additional capital invested in transmission equipment, it is good engineering practice to increase the size of the conductors. The return on the power is affected by a great many factors, such as the cost of the power itself, which may vary from a fraction of a cent to 8 or 10c. per kilowatt-hour; or the character of the installation—it may be a new water-power installation where there is an excess of power. Then no matter what may be the price per kilowatt-hour, it may be good practice to let the waterwheels do a little more work by allowing a greater drop in the line and keep the amount of capital invested in the original project down to a minimum, which may be increased as the load increases on the station, by the addition of a second line. These and many other conditions enter into the most economical size of conductor in a transmission line. But for distributing circuits for lamps and motors, the size is generally determined by the voltage regulation required.

Voltage Regulation of Different Circuits.—On lighting circuits the voltage regulation should be very close, while on motors it will depend somewhat upon the speed regulation required, the type of motors, etc. However, as previously stated, this should not be much in excess of 5 per cent. To determine the size of a conductor in a distributing system to transmit a given power, it is necessary to know certain factors; namely, the value of the current in amperes, the length of the circuit one way, and the allowable voltage drop.

For example, consider a case where 175 amperes is to be transmitted 625 ft. one way, with 3.5 per cent volts drop in the line, the voltage at the source being 236. The voltage drop in this case is

$$E_d = \frac{E \times \text{per cent. drop}}{100} = \frac{236 \times 3.5}{100} = 8.26 \text{ volts.}$$

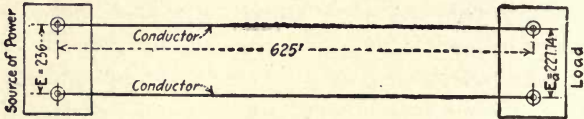

FIG. 131.—Power feeder circuit.

This 8.26 volts is used up in causing the 175 amperes to flow through the two conductors, leaving an available voltage E_a at the load equal to the difference between the total volts E and the volts drop E_d , or $E_a = E - E_d = 236 - 8.26 = 227.74$ volts available at the load, as shown in Fig. 131. This gives a condition similar to that shown in Fig. 132,

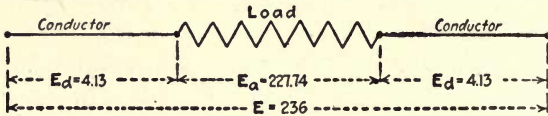

FIG. 132.—Schematic arrangement of circuit, Fig. 131.

of three resistances in series, two of them being the conductors and the third the load. We have learned in previous chapters that the resistance of any circuit or section of a circuit is equal to the volts impressed upon the circuit, divided by the current. Hence in our problem the allowable resistance of the two conductors is equal to volts drop in the conductors, divided by the current flowing through them. Therefore the resistance of the two conductors is

$$R = \frac{E_d}{I} = \frac{8.26}{175} = 0.0472 \text{ ohm.}$$

That is, the two conductors may have 0.0472 ohm resistance and cause only 8.26 volts drop when 175 amperes is flowing through them.

The resistance of 0.0472 ohm is that due to the outgoing and return conductors, each of which is 625 ft. long, or a total length of 1,250 ft. The resistance for 1,000 ft. equals the total resistance R multiplied by 1,000 divided by the total length L . Hence

$$\text{Resistance per 1,000 ft.} = \frac{R \times 1,000}{L} = \frac{0.0472 \times 1,000}{1,250} = 0.0378 \text{ ohm.}$$

In the sixth column from the left-hand side of the wire table will be found the resistance per 1,000 ft. of different size conductors. The size of wire may be determined in our problem by referring to the table and

finding a conductor that has a resistance of 0.0378 ohm per 1,000 ft. The nearest resistance per 1,000 ft. that we find in the table is 0.0350. This is for a 300,000-cir.mil. conductor and would be the size that must be used if the volts drop is not to exceed 8.26 when 175 amperes is passing through the circuit.

The resistance of the conductor chosen is slightly less than that calculated, consequently the volts drop in the line will be less. With 175 amperes flowing in 1,250 ft. of 300,000-cir.mil. conductor, the volts drop will be, *resistance per 1000 ft. × total length in feet × total current ÷ 1000*, or $0.0350 \times 1,250 \times 175 \div 1,000 = 7.66$ volts, against 8.26 calculated as the allowable.

Another thing that we must keep in mind is the requirement of the National Board of Fire Underwriters' regulations, and see to it that a size of conductor is not used smaller than that prescribed in the table. Referring to the table for the size of conductors to carry 175 amperes, it is found to be No. 000 for rubber-covered wire, No. 00 for varnished-cloth, and No. 0 for other insulations. In the case of the No. 0, it is allowed to be loaded up to 200 amperes, but No. 1, the next size smaller, will carry only 150 amperes, therefore No. 0 will have to be used if the size of wire is chosen according to the table. Taking the case of the No. 000 rubber-covered conductor, which can be installed for 175-ampere load, it has a resistance of 0.0625 ohm per 1,000 ft., and with 175 amperes flowing through 1,250 ft. of this conductor, the volts drop will be $0.0625 \times 1,250 \times 175 \div 1,000 = 13.67$ volts, which is considerably in excess of what was decided to be the allowable drop. Consequently the size conductor calculated will have to be used.

Calculating Size of Conductors.—Another method of determining the size of the conductors, in which no wire table is required, is by the formula,

$$\text{Cir.mils} = \frac{21.4DI}{E_d}$$

where D equals the distance one way in feet, and I and E_d as already indicated. In this problem

$$\text{Cir.mils} = \frac{21.4 \times 625 \times 175}{8.26} = 283,369$$

This value would be the exact size. However, the nearest standard size is 300,000 cir.mils in cross-section, and is the size of conductor that will have to be used.

If the resistance of a 400-ft. conductor 65,000 cir.mils. in cross-sectional area is 0.45 ohm, find the resistance of 1,000 ft. of conductor made of the same material 32,500 cir.mils. cross-sectional area.

If the conductors were the same size in both cases, the resistance would vary directly as the length and would have been determined by the proportion

$$400 : 1,000 :: 0.45 : x \quad \text{or} \quad x = \frac{1,000 \times 0.45}{400} = 1.125 \text{ ohm.}$$

In this problem the cross-section of the conductor is decreased by 2 (from 65,000 to 32,500 cir.mils), consequently the resistance for a given length will be doubled, or the resistance in this problem is $2 \times 1.125 = 2.25$ ohms.

A round conductor 750 ft. long and 350 mils diameter weighs 168 lb.; find weight of a conductor made from the same material 1,200 ft. long and 922 mils diameter.

In this problem if the conductors were of the same size in both cases, the weight would vary directly as the length, and the weight of the second conductor could be determined by the proportion $750 : 1,200 ::$

$168 : x$, from which $x = \frac{1,200 \times 168}{750} = 268.8$ lb. The diameter of the

conductors in this problem is increased from 350 to 922 mils, hence the weight will also be increased, owing to the increased size of the conductors. The cross-section of a round conductor varies directly as the square of the diameter. Hence the weight of the 1,200-ft. conductor will be

$350^2 : 922^2 :: 268.8 : x$, from which $x = \frac{922 \times 922 \times 268.8}{350 \times 350} = 1,865.3$ lb.

The resistance of 650 ft. of copper, 83,690 cir.mils in cross-section is 0.0818 ohm. Find the resistance of 1,500 ft. of round copper 707 mils in diameter.

If both conductors had the same cross-sectional area, the resistance of the 1,500-ft. conductor would be found by the proportion $650 : 1,500 :: 0.0818$

$: x$, from which $x = \frac{1,500 \times 0.0818}{650} = 0.189$ ohm. The diameter of the

1,500-ft. conductor is 707 mils; then the cross-sectional area in circular mils will be diameter in mils squared, or $707 \times 707 = 499,849$. Since the cross-sectional area of the 1,500-ft. conductor has been increased over that of the 650-ft. conductor, the resistance of the former for a given length will be decreased and will be found by the proportion

$499,849 : 83,690 :: 0.189 : x$, from which $x = \frac{83,690 \times 0.189}{499,849} = 0.0316$ ohm.

By referring to the wire table it will be found that the given resistance in the problem was approximately that for 650 ft. of No. 1 conductor, the resistance of which is 0.1258 ohm per 1,000 ft. The conductor of which we calculated the resistance is approximately 500,000 cir.mils in cross-section. The resistance of 1,000 ft. of 500,000-cir.mil conductor as found from the table is 0.021 ohm. Then the resistance of 1,500 ft. would be $0.0210 \times 1.5 = 0.0315$ ohm, against 0.0316 as calculated from the resistance of the 650-ft. conductor.

Find the size of conductor in circular mils required to transmit 235 amperes 875 ft., allowing a drop of 4.5 per cent in the line. The voltage E at the source is 575. Also find the resistance of the line, resistance per 1,000 ft. of conductor, the voltage at the load and the diameter of the conductor in mils.

The volts drop

$$E_a = \frac{E \times \text{per cent drop}}{100} = \frac{575 \times 4.5}{100} = 25.875 \text{ volts.}$$

The voltage at the load $E_a = E - E_a = 575 - 25.875 = 249.125$, and the resistance of the two conductors is

$$R = \frac{E_a}{I} = \frac{25.875}{235} = 0.11 \text{ ohm.}$$

The total length of conductor in the problem is $L = 875 \times 2 = 1,750$ ft.

Then the resistance per 1,000 ft. = $\frac{R \times 1,000}{L} = \frac{0.11 \times 1,000}{1,750} = 0.0629$ ohm.

Referring to the wire table, it is found that the nearest size conductor to one having a resistance of 0.0629 ohm per 1,000 ft. is a No. 000, which has a resistance of 0.0625 ohm per 1,000 ft. The carrying capacities given in the table for a No. 000 wire is 175 amperes for rubber cover, 270 for varnished cloth and 275 amperes for other insulation. If we assume that the conductors are to be used for inside work, and that a rubber-covered conductor is required, we cannot use the size calculated, but must use a larger wire to conform with the National Board of Fire Underwriters' regulations. The size of a rubber-covered conductor that will meet these requirements is 250,000 cir.mils in cross-sectional area. This conductor is rated for 240 amperes and has a resistance of 0.042 ohm per 1,000 ft. The resistance of 1,750 ft. will be $1,750 \times 0.042 \div 1,000 = 0.0735$ ohm, and the volts drop when 235 amperes is flowing through the circuit is $E_a = RI = 0.0735 \times 235 = 17.27$, against 25.874 volts that was allowed. With the larger-sized conductor, the voltage will be maintained more nearly constant at the load with variations in the value of the current.

The size of conductor to transmit 235 amperes 875 ft. with 25.875 volts drop in the line may also be found by the formula,

$$\text{Cir.mils} = \frac{21.4DI}{E_a} = \frac{21.4 \times 875 \times 235}{25.875} = 170,000,$$

which checks up very closely with the cross-sectional area of a No. 000 conductor as given in the table. The diameter of a round conductor in mils is equal to the square root of the cross-sectional area in circular mils, or, in our problem, $\text{diameter in mils} = \sqrt{170,000} = 412$.

Derivation of Circular-Mil Formula.—The formula for finding circular-mil area of a conductor to transmit a given current is based on the resistance of 1 circular-mil-foot of copper. A circular-mil-foot is a wire 1 ft. long and 1 cir.mil in cross-section, or in other words a round wire 1 ft. long by one thousandth of an inch (0.001 in.) diameter. The resistance of 1 cir.mil-ft. of copper is given different values for different temperatures, varying from 10.5 to 11 ohms, 10.7 ohms being a good average value. The foregoing statement means that if a round section 1 ft. long and 0.001 in. diameter is taken from any copper wire, it will have a resistance of 10.7 ohms at a temperature of about 70 deg. F.

If we take a 1-ft. section of a conductor and consider this made up of a number of wires in parallel, each element 1 cir.mil in cross-sectional area, each one of these little wires will have a resistance of 10.7 ohms, and if the cross-sectional area of the conductor is equivalent to 100 cir.mils, the resistance of the 1-ft. section will be $10.7 \div 100 = 0.107$ ohm. Looking at this in another way, if the conductor is 100 cir.mils in cross-section, we have a condition similar to that if the wire was made up of 100 wires each 1 cir.mil in cross-section. In this case the same law will apply as when connecting equal resistances in parallel; that is, the joint resistance of the group would equal the value of one resistance divided by the number connected in parallel. In our problem we considered that the 1-ft. section of conductor was made up of 100 wires 0.001 in. in diameter and that each wire had a resistance of 10.7 ohms. Since there are 100 in parallel, the joint resistance will be $\frac{10.7}{100}$, or 0.107 ohm. If the cross-sectional area of the 1-ft. section was equivalent to 1,000 cir.mils, then the resistance of the piece would be $10.7 \div 1,000 = 0.0107$ ohm.

Resistance per Foot of Conductor.—From the foregoing it is evident that the resistance of a 1-ft. section of any copper conductor is equal to 10.7 divided by the circular-mil cross-section. Take, for example, a No. 8 wire. Its resistance is 0.641 ohm per 1,000 ft. This is equivalent to 0.000641 ohm per foot. The sectional area of a No. 8 wire is 16,510; then the resistance per foot equals $10.7 \div \text{cir.mils} = 10.7 \div 16,510 = 0.000648$ ohm, against 0.000641 ohm given in the foregoing. As another example, take a 300,000-cir.mil conductor, the resistance of which is 0.035 ohm per 1,000 ft., or 0.000035 ohm per foot. From the method described, the resistance per foot = $10.7 \div \text{cir.mils} = 10.7 \div 300,000 = 0.0000356$ ohm, which checks up fairly close to that given in the wire table.

Since we have a method for determining the resistance per foot of any copper conductor, all that is necessary is to multiply the result thus obtained by the length of the conductor in feet to find the total resistance. If we denote the length of the conductor by L , then the resistance of the conductor is $R = \frac{10.7L}{\text{cir.mils}}$.

To illustrate, the resistance of 1,750 ft. of No. 2 conductor is 0.276 ohm, as calculated from the resistance per 1,000 ft. given in the wire table, and the cross-sectional area is 66,370 cir.mils. Calculating the resistance from the foregoing formula,

$$R = \frac{10.7L}{\text{cir.mils}} = \frac{10.7 \times 1,750}{66,370} = 0.282 \text{ ohm}$$

against 0.276 ohm as calculated from the data given in the wire table.

Since circular mils is one of the elements in the formula for finding the resistance R , the expression may be made to

read $\text{cir.mils} = \frac{10.7L}{R}$ for finding the circular mils. The

lengths of circuits are usually expressed in the distance one way, and not in the total length of wire in them, and the value of the volts drop and current transmitted are more readily at

hand than the resistance of the circuit. Therefore, we will express the length L of the conductor in the two-wire circuits by $2D$, where D equals the distance one way, and the resistance of the conductors is as already shown to be, $R = \frac{E_a}{I}$. By substituting these equivalents for L and R in the formula, the expression becomes

$$\text{Cir.mils} = \frac{10.7 \times 2D}{\frac{E_a}{I}} = \frac{21.4DI}{E_a}$$

which is the formula we use to find the size of conductors in the foregoing. The formula may be transposed to read:

$$E_a = \frac{21.4DI}{\text{cir.mils}}$$

for finding the volts drop in a given circuit, or to read

$$I = \frac{\text{cir.mils} \times E_a}{21.4D}$$

for finding the current that may be transmitted through a given circuit with a given allowable voltage drop.

1. In a circuit 750 ft. long, one way, in which 350,000-cir.mil conductors are used, if the voltage at the load is 230 when 175 amperes is being transmitted, find the volts drop in the line, the volts at the source of power, the resistance of the conductor, the total watts supplied to the line, the watt loss in the line and the watts supplied to the load.

The volts drop in the line, in this problem, is

$$E_a = \frac{21.4DI}{\text{cir.mils}} = \frac{21.4 \times 750 \times 175}{350,000} = 8 \text{ volts.}$$

The volts E at the source of power equal the sum of the volts E_a at the load and the volts drop E_d , or $E = E_a + E_d = 230 + 8 = 238$. Resistance of the line is $R = \frac{E_d}{I} = \frac{8}{175} = 0.045$ ohm. Figuring another way, the resistance of the line will be the resistance of 1,500 ft. of 350,000-cir.mil conductor; referring to the wire table, this size conductor will be found to have a resistance of 0.03 ohm per 1,000 ft., or $65 \times 0.03 = 0.045$ ohm per 1,500 ft. The total watts W supplied to the system are equal to the total volts E times the total current I , that is, $W = EI = 238 \times 175$

=41,650; watts loss W_l in the line equals the volts drop E_d times the current I , or $W_l = E_d I = 8 \times 175 = 1,400$; the watts W_a supplied to the load are equal to the volts E_a at the load times the current I ; hence $W_a = E_a I = 230 \times 175 = 40,250$, and the sum of the watts lost and those supplied to the load should be equal to the total watts, or $W = W_l + W_a = 1,400 + 40,250 = 41,650$. This checks with the first method.

A 1,000-kw 120-volt compound-wound generator furnishes current to a lamp load at a distance of $\frac{3}{8}$ mile and is adjusted to maintain constant voltage at the load. The voltage drop in the line at full load is chosen to be 10 per cent. of the normal voltage. What size wire is required if 2,100 forty-watt lamps are turned on? What percentage of its full-load capacity would the generator be delivering? What would be the voltage at the generator? What would be the watts loss in the line? What percentage of the load supplied would the line loss be?

First, it was required to find the size of wire required to limit the line drop to 10 per cent. of the normal voltage. Since 120 volts is the normal voltage, the voltage drop in line would be 10 per cent. of 120 volts or $\frac{1}{10} \times 120 = 12$ volts. The resistance of the line would be the voltage drop in it divided by the current flowing through it. The current flowing would be the watts taken by the load divided by the voltage. The load consists of 2,100 forty-watt lamps and would therefore be $2,100 \times 40 = 84,000$ watts. Consequently the line current would be this number of watts divided by 120 volts, or $\frac{84,000}{120} = 700$ amperes. The resistance of the line would therefore be the voltage drop divided by this current, or $\frac{12}{700} = 0.01714$ ohm. There are two lines each $\frac{3}{8}$ mile long, making a total length of $\frac{3}{4}$ mile. Since there are 5,280 ft. in a mile, the total length of wire in the line is $\frac{3}{4} \times 5,280 = 3,960$ ft. The resistance per thousand feet would be the total resistance of the line divided by its length in feet multiplied by one thousand, or $\frac{0.01714}{3,960} = 1,000 = 0.004329$ ohm per thousand feet.

From the wire table it is found that a 2,000,000-cir.mil cable has a resistance of 0.005177 ohm per 1,000 ft., which is greater than the resistance required. Since this is the largest cable in general use, it would be necessary to use two cables in multiple to meet the conditions. We could use one cable of 2,000,000 cir.mil and a smaller one of such size as to reduce the resistance to the value desired, but the more usual way would be to use two like cables of such size as would give the required resistance when placed in multiple. When two conductors of the same resistance are placed in multiple the combined resistance is one-half the resistance of either one, which is the same as saying that the resistance of either is twice their combined resistance. In the case of our problem

the combined resistance is to be 0.004329 ohm per 1,000 ft.; hence the resistance of each of the two conductors would be twice that value, or $2 \times 0.004329 = 0.008658$ ohm per 1,000 ft. From the wire table we find that a 1,250,000-cir.mil cable has a resistance of 0.008282 ohm per 1,000 ft. and this would therefore be the required size. The total resistance would be slightly less than that specified, and we might try whether it would be possible to use one 1,250,000-cir.mil and one 1,000,000-cir.mil cable. The resistance of the latter size is 0.010353 ohm per 1,000 ft. and the combined resistance of the two would be their product divided by their sum, or $\frac{0.008282 \times 0.010353}{0.008282 + 0.010353} = 0.004601$ ohm per 1,000 ft., which proves to be too great; consequently two 1,250,000-cir.mil cables would be used.

As already found, the generator would be delivering 84,000 watts to the lamps, which is equal to 84 kw. Since the capacity of the generator is 1,000 kw., the lamp load would be $\frac{84}{1,000}$ of its capacity, or 8.4 per cent.

The voltage at the generator would be the voltage at the lamps plus the volts drop in line, or $120 + 12 = 132$ volts. The watts lost in the line would be equal to the line current, 700 amperes, multiplied by the volts drop in line, 12 volts, which gives $700 \times 12 = 8,400$ watts loss.

The load supplied has been found to be 84,000 watts; the line loss is 8,400 watts. To find what percentage of load supplied the line loss amounts to, we divide the line loss by the load and multiply by 100, which gives $\frac{8,400}{84,000} \times 100 = 10$ per cent.

CHAPTER X

FUNDAMENTAL PRINCIPLES OF DYNAMO-ELECTRIC MACHINERY

Electromagnetic Induction.—So far we have considered only the production of an electromotive force as generated in a battery cell by electrochemical action and by thermal action on the junction of two dissimilar metals. The most important method, and the one upon which the successful application of electricity to-day depends is what is called electromagnetic induction—the principle discovered in 1830 by Michael Faraday at the Royal Institution, London, England—that an electric pressure is set up in a conductor when it is moved across the field of influence of a magnet.

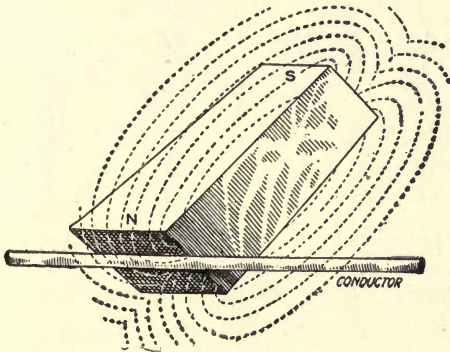

FIG. 133.—Conductor in a magnetic field.

This principle is illustrated in Fig. 133, where a magnet is shown with a conductor located in its field of force. If the conductor is moved upward or downward across the lines of force at right angles to them, an electric pressure will be set up in the conductor, and if its two ends are closed

through another conductor, an electric current will flow. It does not make any difference whether the conductor or the magnet is moved as long as there is a relative movement of the conductor through the magnetic field not parallel to the lines of force.

Fig. 134 shows the general idea embodied in the first dynamo used by Faraday. The device consists of a copper disk supported so that it could be revolved between the poles

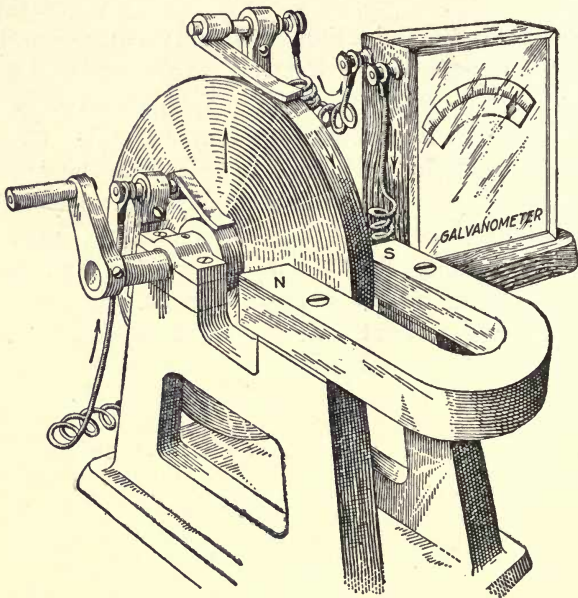

FIG. 134.—Illustrates principle Faraday's first dynamo.

of a horseshoe magnet. Brushes rest on the shaft and the periphery of the disk, so that when the disk is revolved a current of electricity flows through the circuit. This is the principle upon which all dynamo-electric machinery is constructed at the present time. It has been ninety years since Faraday made this discovery, that when a conductor is moved across a magnetic field an electromotive force is generated in the former, yet with all the effort that has been given to finding out why this is so by hundreds of scientists,

the question still remains unanswered. Although we do not know why an electromotive force is produced in a conductor when it is moved across a magnetic field at right angles to the lines of force we understand the laws that govern the generation of an electric pressure by this means and are therefore able to design very efficient electrical machinery.

Rule for Determining Direction of Electromotive Force.

—The direction of the electromotive force as generated in a conductor cutting the field of a magnet depends upon the direction of the lines of force and the direction and motion

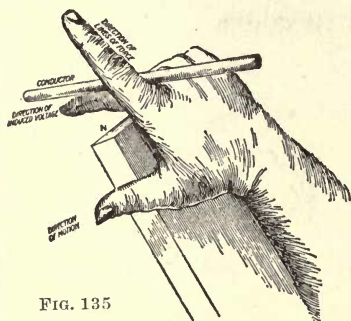

FIG. 135

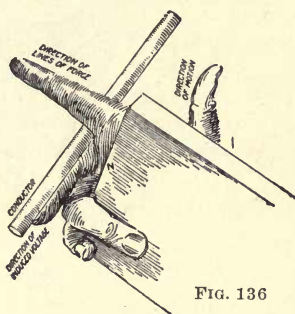

FIG. 136

FIGS. 135 and 136.—Right-hand rule for determining direction of voltage generated in a conductor cutting the field of a magnet.

of the conductor. There are a number of rules for determining the direction of the voltage when the direction of the lines of force and that of the conductor are known, but the one shown in Fig. 135 is about the simplest, most convenient and chiefly used. This method consists of placing the thumb and first two fingers of the right hand at right angles to one another, as shown in the figure. Then if the forefinger points to the direction of the lines of force and the thumb the direction in which the conductor is moved, the middle finger will indicate the direction of the voltage or current. In the figure the direction of current flow or voltage is away from the reader. If the motion of the conductor is reversed as in Fig. 136, the direction of the voltage or current will be reversed. The same would be true if the motion of the conductor were

the same as in Fig. 135, but the polarity of the magnet changed; that is, the direction of the lines of force changed. If both the direction of the motion of the conductor and the lines of force are changed, the direction of the electromotive force will not be changed. For example, taking Fig. 136 as the original condition, then Fig. 137 shows the condition when the direction of both the conductor and lines of force have been changed. It is seen that the forefinger points in the same direction in both cases, or in other words, the direction of the voltage is the same under both conditions. From

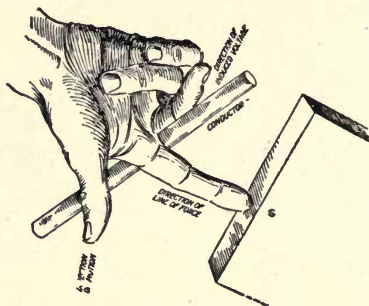

Fig. 137.—Same as Fig. 135, except that both the direction of the conductor and lines of force are reversed.

this the deduction may be made that in order to reverse the direction of the electromotive force generated in a conductor, it is necessary to change the direction of motion of either the conductor or the lines of force, but not both.

Lines of Magnetic Force.—In Chapter II it was pointed out that the term “lines of force” is only figurative, because in the true sense, or at least as far as we know, such a thing as a definite line does not exist. Therefore, the lines which are generally shown in pictures of magnets are used only to indicate that there is a flow of “something” from the N to the S pole of the magnet and the direction of the flow. If the like poles of two magnets are placed one centimeter, approximately one-third inch apart, as shown in Fig. 138, and they repel each other with a force of one dyne, the mag-

netic field is said to be of unit strength. This unit is known as the centimeter-gram-second (c.g.s.) unit and is equivalent to $\frac{1}{445000}$ pounds.

Therefore, one line of magnetic force is just what the term would imply; namely, a force, just as one fan blowing against another creates a force which would tend to separate them. To express the magnetic unit more accurately, when two magnets of equal strength, of 1 sq. cm. cross-section each,

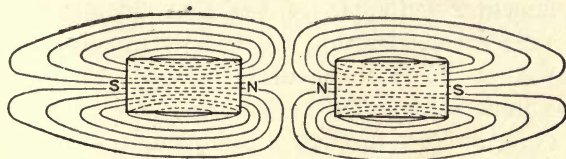

FIG. 138.—Shows a repulsion between two like magnetic poles.

are placed 1 cm. apart in air and repel each other with a force of one dyne, they are said to be of unit strength.

Unit Electromotive Force.—Taking a magnet having a field of unit strength, that is, one line of force per square centimeter, and moving a conductor through this field at a uniform rate so that it will cut across it in one second, there would be generated in the conductor what is called a unit electromotive force. In other words, if a conductor cuts one line of force per second, it will generate a voltage of unit value. This unit has never been given any other name than unit electromotive force. It is a theoretical unit and is used only in establishing the relation between it and other electrical and magnetic theoretical units.

The value of this theoretical unit of voltage is so small that it would be very inconvenient to use in practice, and to get a unit for use in practice 100,000,000 of these theoretical units are combined into one and called a volt. Expressing this another way, when a conductor cuts 100,000,000 lines of force per second, at a uniform rate, it will have one volt of electric pressure generated in it.

Right here is where we should distinguish between the number of lines of force cut and the rate at which they are cut. It is not necessary

for a conductor to move for one second and cut 100,000,000 lines of force at a uniform rate in that time, in order that one volt be generated in it. If such were the case, it would have one volt generated in it during the period of one second. On the other hand, if the conductor was in motion for only one-hundredth of a second and cut 1,000,000 lines of force, it would have generated in it one volt, the same as when cutting 100,000,000 lines of force in one second—the rate of cutting is the same in both cases. From this it is seen that all that is necessary to generate one volt is for the conductor to cut the lines of force at a rate equivalent to 100,000,000 per second. This might be called the starting point in the design of all dynamo-electric machinery.

Fundamental Principle of the Electric Motor.—Before giving further consideration to the electric generator, it is necessary that the fundamental principle of the electric motor be understood. We have already seen that when an electric current flows through a conductor it sets up a magnetic field about the latter, as in Fig. 139, and that when a conductor moves across a magnetic field so as to cut the lines of force, an electromotive force is generated in the conductor, which will cause a current to flow if the ends of the conductor are connected together. This brings up the question of what effect a magnetic field has upon a conductor carrying a current when the latter is placed in the former. Fig. 140 shows a horseshoe magnet, the magnetic field of which will be, if not subjected to an influence, uniformly distributed as indicated. If a conductor through which a current is flowing is brought near the field of a magnet, as in Fig. 141, the result will be that shown in the figure. If the current is flowing up through the plane of the paper, the lines of force about the conductor adjacent to the field of the magnet are in the same direction as those of the latter. This being the case, the two fields are forced in together between the conductor and the magnet and cause a distortion of both as shown. Lines of magnetic force always act like elastic bands in tension; they may be distorted, but tend to take the shortest path, and that is just what is illustrated in Fig. 141. Under the conditions shown, the field of force of the magnet tends to push the field of the conductor and along with it the conductor to the left, as indicated by the arrow.

If the conductor is placed in the center of the magnetic field, as in Fig. 142, the result will be as given. The flux from the magnet and about the conductor are in the same direction on the right-hand side of the latter, but opposed on the left-hand side. Consequently, part of the flux from the magnet on the left-hand side of the conductor will be distorted to the right side, as shown, causing even a greater distortion of the field than in Fig. 141, and will also tend to cause the conductor to move to the left. What we have just



FIG. 139

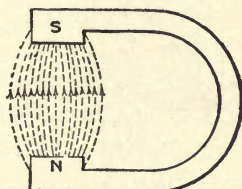

FIG. 140

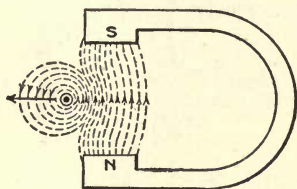

FIG. 141

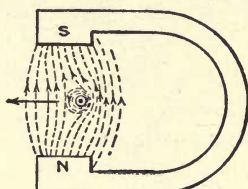

FIG. 142

FIGS. 139 to 142.—Illustrate the fundamental principle of the motor.

seen is the fundamental principle of the electric motor and may be expressed thus: A conductor carrying a current in the field of a magnet tends to move to cut the lines of force of the latter at right angles. This, it will be seen, is the inverse of the fundamental principle of the electrical generator, which is, a conductor moved across a magnetic field so as to cut the lines of force has an electromotive force induced in it.

Direction Conductor Will Move in a Magnetic Field Depends Upon the Direction of the Current.—It is evident from what we have seen in Figs. 141 and 142 that the direction the conductor will tend to move in depends upon the

direction of the current in the conductor and the lines of force of the magnetic field. The direction can be determined in the same way as for the direction of the electromotive force developed in a conductor, but using the left hand instead of the right. Placing the first three fingers of the left hand at right angles to each other, as in Fig. 143, if the middle finger points in the direction of the current in the conductor and the forefinger in the direction of the lines of force, then the thumb will always point in the direction that

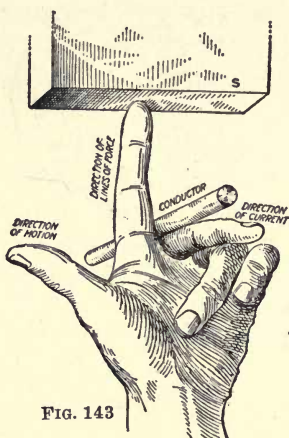

FIG. 143

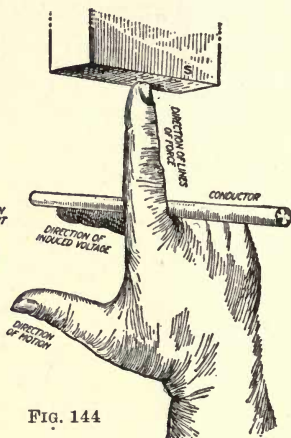

FIG. 144

FIG. 143.—Left-hand rule for a motor.
 FIG. 144.—Right-hand rule for generator.

the conductor will tend to move in. Hence, if either the direction of the current or the lines of force are reversed, the direction of motion of the conductor will be reversed. This is true in all cases, when the rotational direction of a direct-current motor's armature is reversed; the direction of the current is reversed through the armature conductors or through the field coils, the latter changing the direction of the magnetism of the field poles.

Counter-Electromotive Force.—In Fig. 142 we have seen that with the lines of force and current in the direction indicated, the conductor will tend to move to the left. As soon

as the conductor begins to move, it will be cutting the field of the magnet. Consequently, an electromotive force will be generated in the former. By applying the rule, Fig. 144, for the direction of the electromotive force in the conductor, it will be seen that the generated electromotive force is opposite to the direction of the current; that is, the voltage developed in the conductor is opposite to the pressure that causes the current to flow in the conductor. This back pressure, as it may be termed, is called a counter-electromotive force and, as will be seen in Chapter XVI, is an important factor in the operation of the electric motor. What has been shown in this and in Chapter XII indicates that whenever a conductor moves in a magnetic field or a magnetic field is moved across a conductor so that lines of force are cut, no matter what the conditions may be, there will always be a voltage induced in the conductor. From this very fact many of the most serious problems in the operation of electrical machinery and circuits arise.

How an Electric Generator is Loaded.—In Fig. 145, if the conductor is moved upward, as indicated, a voltage will be induced in it that will cause a current to flow in the direction shown. However, from what we have learned in the foregoing, when the current flows in the conductor it will tend to cause the latter to move in a direction to cut the lines of force or, in other words, produce the condition of an electric motor. This is just what would happen in Fig. 145. Mechanical force is applied to cause the conductor to move upward, which causes the current to flow in the circuit. The magnetic field set up by the current in turn reacts upon the flux from the magnet and also tends to impart motion to the conductor. By applying the rule for the direction of motion of the conductor due to the current it is seen that it tends to move downward, or opposite to the direction the mechanical force is causing it to move in. This point brings out the way that an electric generator is loaded. The source of driving power turns the armature in a given direction, which produces a voltage and causes a current to flow; the current

flowing through the armature conductors in turn produces a reverse, or counter-turning effort to that produced by the steam engine or other source of motive power driving the generator. However, the counter-turning effort caused by the action of the current on the magnetism from the poles cannot be so great as the applied power, or the machine would stop. But the greater the number of amperes supplied by the armature for a given voltage, the greater the counter-turning effort. Consequently, the source of motive power will have to develop a greater effort to overcome that pro-

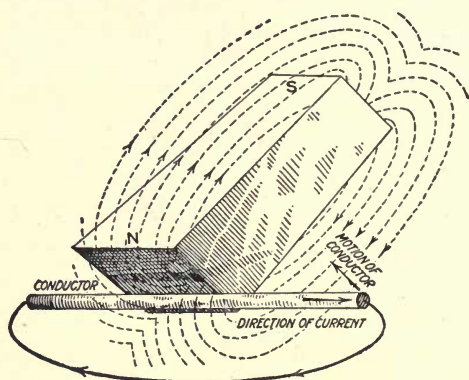

FIG. 145.—Illustrates how current is caused to flow in a circuit.

duced by the current. The same way with a motor, the counter-electromotive force cannot be so great as the applied voltage, or no current would flow through the conductors on the armature and the machine would stop. The foregoing shows that the electric motor and the generator are very closely interrelated. In fact, the fundamental principle of one is always embodied in the other. The machine that can be used for a motor can also be used for a generator, the only difference in their design being slight modifications to obtain certain desired characteristics.

Simplest Form of Electric Machine.—The windings on the armature of a generator consist of a series of loops or coils grouped in various ways, depending upon the type of

machine, voltage, etc. The simplest form would be one loop arranged to revolve between the north and the south pole of the magnet as shown in Fig. 146. The ends of the loop connect to the rings R_1 and R_2 , with brushes B_1 and B_2 resting on the latter to form a rubbing contact between the revolving loop and the stationary external circuit C . Considering the loop to revolve in a clockwise direction, as indicated by the curved arrow, the side of the loop under the N pole will be moving downward while the side under the S pole will be moving upward. The lines of force are from the N to the S pole; therefore, by applying the rule for the direction of the electromotive force generated in a conductor cutting lines of force, it will be found to be as given by the arrows on the two sides of the loop, which is away from the reader under the N pole and toward the reader under the S pole. This is just as it should be, since the lines of force are in the same direction under each pole, but the direction of the conductor under one pole is opposite to that under the other.

Factors Governing Value of the Voltage.—By tracing around through the loop it will be seen that the e.m.f. generated in the side under one pole is added to that under the other pole. Or, in other words, we have the same condition as when two voltaic cells are connected in series, and if two volts are generated in one conductor, the two conductors in series will generate four volts. Hence, it is seen that one of the factors which govern the voltage of a given generator would be the number of conductors connected in series. For example, if instead of only one turn in the coil, as in Fig. 146, we have two turns in series, as in Fig. 147, and if the coil is revolved at the same rate and the magnetic density the same in both cases, then each conductor under a pole will have equal voltage generated in it. Again, by tracing through the coil, it will be seen that four conductors are in series; consequently the voltage generated in the coil will be four times that in one conductor, or in other words the voltage increases as the number of turns in the coil is increased.

Another way to increase the voltage would be to increase

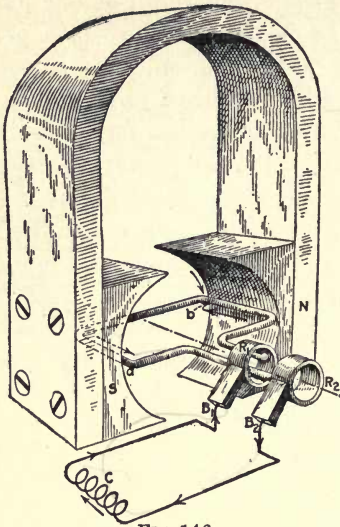

FIG. 146

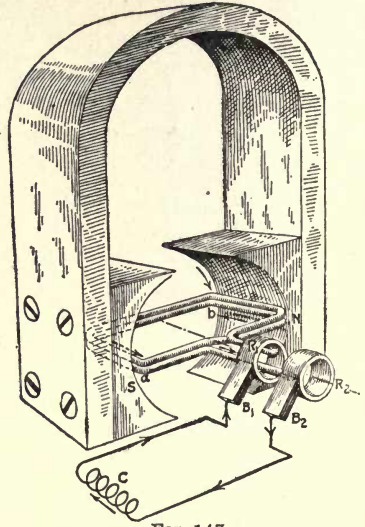

FIG. 147

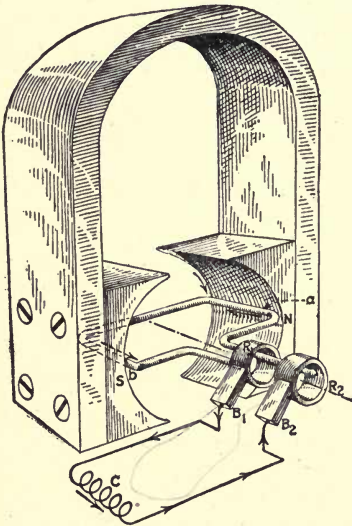

FIG. 148

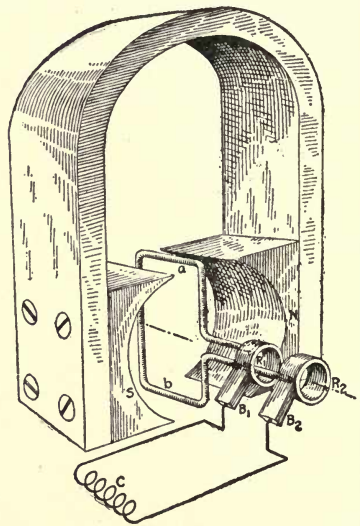

FIG. 149

FIGS. 146 to 149.—Single-coil alternating-current generators.

the speed of the coil; that is, if the number of revolutions per minute made by the coil was doubled, the number of lines of force cut by each conductor would be doubled. Consequently, the voltage would be increased by two. A third way that the voltage generated in the coil may be varied is by changing the number of lines of force in the magnetic field. If the speed of the coil remains constant, but the strength of the magnetic field is doubled, then double the number of lines of force will be cut in a given time. The latter is the one way usually employed for varying the voltage of all modern generators and is treated in Chapter XIII.

Current Reverses in External Circuit.—In Fig. 146 the flow of the current is from conductor a to ring R_2 and brush B_2 through the external circuit C and back to brush B_1 and ring R_1 and back into conductor b , thus completing the circuit. When the coil has made one-half revolution, as shown in Fig. 148, conductor a will be under the N pole and conductor b under the S pole, as shown, with the result that the direction of the voltage generated in the two conductors is reversed. The direction of the e.m.f. in conductor a , Fig. 146, is toward the reader, but in Fig. 148 it is away; in b , Fig. 146, the direction is away from, while in Fig. 148 it is toward the reader. The result of this change in direction of the voltage in the coil is a change in direction of the current in the external circuit, as indicated by the arrowheads. From this it will be seen that on one-half of the revolution the current is flowing through the circuit in an opposite direction to that on the other half of the revolution; that is, the current is caused to flow back and forth through the circuit. If the voltage in the armature conductors change in direction as they pass alternate north and south poles there must be some position where the voltage is zero; this is indicated in Fig. 149.

When the coil is in the position shown in Fig. 149, it is moving parallel with the lines of force and is therefore not cutting them, and consequently not producing any voltage. From this point the voltage increases until the conductors are at the center of the polepieces, where they are moving at right

angles to the lines of force and are therefore cutting the flux at a maximum rate, consequently producing a maximum pressure. For the next quarter of a revolution the voltage decreases to zero.

Electromotive Force or Current Curve.—The series of values that the voltage or current passes through in the coil during one revolution may be expressed in the form of a curve, Fig. 152. The distance along the straight line between the two

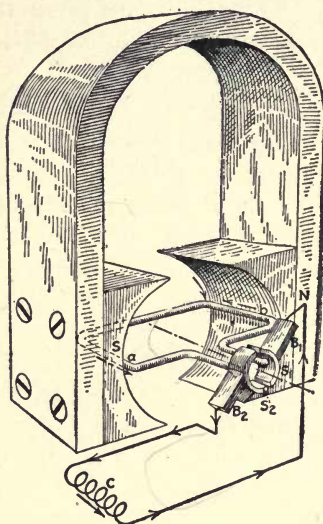

FIG. 150

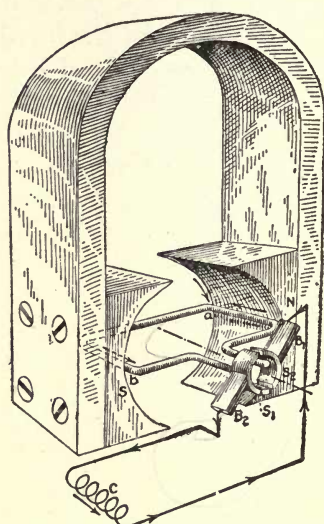

FIG. 151

FIGS. 150 and 151.—Single-coil direct-current generators.

zero points of one curve represents the time required by the coil to pass the pole faces, or in Figs. 146 to 149 to make one-half revolution. The vertical distance between the line and the curve at any point represents the value of the voltage or current in the coil at that instance. The curve above the line represents current or voltage in one direction, while the curve below the line represents current or voltage in the opposite direction. A current or electromotive force that changes in direction in the circuit as shown in the foregoing is called an alternating current or electromotive force.

The voltage generated in the armature of all commercial types of generators is alternating, no matter whether the current in the external circuit flows in one direction or is alternating back and forth. If we want the current to flow in one direction in the external circuit, or, as it is usually called, a direct current or continuous current, some means must be provided to change the alternating voltage generated

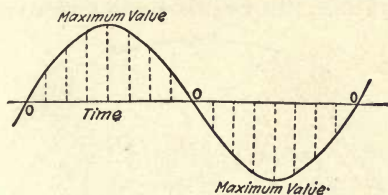

FIG. 152.—Alternating-current or voltage curve.

in the armature coils to one that is always in the same direction in the external circuit.

In Fig. 150 is shown a scheme that will maintain the voltage in one direction in the external circuit. Instead of the ends of the coils connecting to two rings, as in Figs. 146 to 149, they connect to the two halves of a divided ring. In the coil position shown, brush B_1 rests on segment S_1 and the current in the external circuit is in the direction indicated. When the coil has revolved one half revolution as in Fig. 151, brush B_1 is resting on segment S_2 , and although the current has reversed in the coil from that in Fig. 150, it is maintained in the same direction in the external circuit, as indicated by the arrowheads.

Although the voltage is applied in one direction to the external circuit, the current will not be of a constant value on

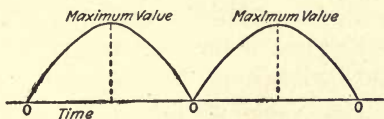

FIG. 153.—Pulsating-current or voltage curve.

account of the varying value of the voltage. What will be obtained is a current that flows in waves, as shown in Fig. 153

and is known as a pulsating current. To obtain a constant current for a given value of resistance in the external circuit, or, as it is usually called, a direct current, it is necessary to have a number of coils on the armature and the ring divided into as many sections as there are coils.

Machine with Ring-Type Armature.—So far we have only considered dynamos that have one coil of a single turn of wire on the armature. In Fig. 154 is shown, diagrammatically,

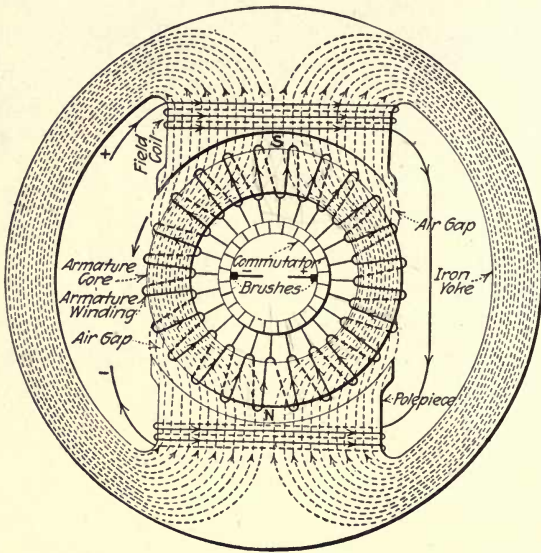

FIG. 154.—Diagrammatic representation of ring-armature type generator.

the complete layout of a dynamo-electric machine having an armature of the ring type. Coils of wire, designated field coils, are placed on the polepieces. The winding on the armature is shown, for simplicity's sake, to be continuous for the entire circumference of the core and closed on itself, with a tap taken out at each turn of the winding to a bar or segment in the commutator. This winding could have been shown grouped into coils, as in Fig. 155, with the leads of each coil coming out to two commutator bars, as shown, which is generally the way the job is done in practice, but for our purposes

Fig. 154 is better suited. The winding in Fig. 155 has twice as many turns as that in Fig. 154, consequently, will generate twice the voltage under a given condition of speed and field strength.

In Fig. 154, if a current is caused to flow through the field coils in the direction shown, it will cause the top polepiece to become south and the bottom one north polarity, and the magnetic flux will flow in the direction indicated. Then, if the

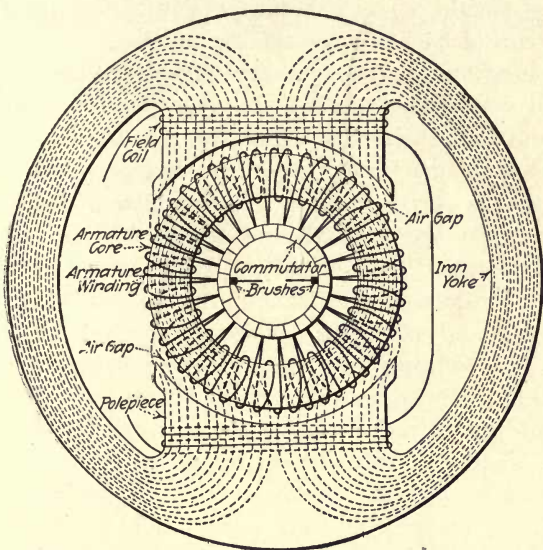

FIG. 155.—Same as Fig. 154, but with two turns per coil on the armature.

armature is revolved in the direction of the curved arrow, the conductors under the S pole will be cutting the lines of force in a left-hand direction, while those under the N pole will be cutting the flux in a right-hand direction. The lines of force are moving upward, from the N to the S pole, in each case, therefore, by applying the rule for determining the direction of electromotive force, it will be found that in the conductors under the S pole the voltage is down through the plane of the paper, while in the conductors under the N pole it is toward the reader, as indicated by the arrowheads. It will be seen that

all the voltages generated in the various conductors under the S pole are in series assisting one another, likewise under the N pole. Therefore, the sum of the voltages generated in the conductors under one pole is the voltage that will appear at the brushes when the latter is in the position shown. It will also be seen that the voltage in the windings under the N pole opposes that generated in the conductors under the S pole. Since the voltages in the two halves of the windings are equal, or at least should be, no current flows in the winding as long as the circuit is open between the two brushes.

The question of electromotive-force generation was discussed to considerable extent in Chapter III, and it was pointed out that the device which supplies the current to the circuit does not generate the current, but produces a voltage that causes the current to flow in a conductor when it is connected between the positive and negative terminals of the source of voltage. This is just the condition we have in Fig. 154. The conductor on each half of the armature cuts the line of force and generates a voltage; however, the arrangement of the winding is such that the voltage in one half opposes that in the other half, and no current can flow around in the winding until the brushes are connected to an external circuit *C*, as in Fig. 156. In the figure the external circuit is shown on the center of the commutator; however, this is for simplicity's sake only, as this circuit might be a motor or a group of lamps, or any device that requires an electric current for its operation, and might be located at a considerable distance from the machine.

A generator in an electric circuit is the same as a pump is in a circulating system. The pump does not generate the fluid that it causes to flow in the system, but creates a pressure that causes the fluid to flow in the pipe line. Likewise an electric generator only produces the pressure that causes the electric current to flow in the circuit.

The two halves of the armature windings in Figs. 154, 155 and 156 are similar to two voltaic cells in parallel. In Fig. 156 it will be seen that the electric pressure generated in the conductors under the N pole causes a current to flow out from

the positive brush through the external circuit *C* and into the negative brush, as indicated by the arrowhead; likewise, for the conductors under the S pole. Since the two halves of the windings are in parallel, the voltage appearing at the brushes will be that developed in one half of the winding, just as when two voltaic cells are connected in parallel—the voltage of the group is equal to that of a single cell. Also, each half of the winding will supply one-half of the current in the external circuit; that is, when the armature is supplying 30 amperes to

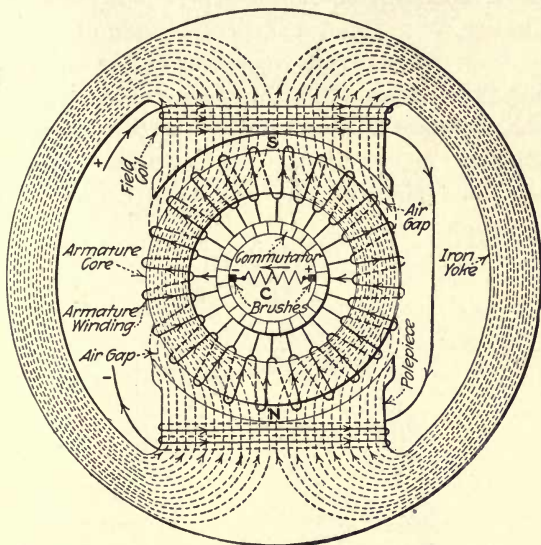

FIG. 156.—Same as machine in Fig. 154, but with brushes connected to an external circuit.

the external circuit *C*, 15 amperes will be flowing in the conductors under the N and 15 amperes in the conductors under the S pole. This is again the same as when two voltaic cells are connected in parallel and supplying current to a circuit—one-half of the current is supplied by each cell.

Although the foregoing discussion has been in reference to two-pole machines, the general principle applies equally to multipole machines, although the division of the current may be somewhat different in the armature windings.

CHAPTER XI

DIRECT-CURRENT MACHINERY CONSTRUCTION

Types of Armatures.—Direct-current armatures may be classed under two general types—ring and drum. Both types get their names from the shape of the core. The core of the ring type consists of an iron ring about which the coils are wound, as shown in section in Fig. 157, where the coils on a drum armature are placed on the surface of the core, or in slots in the surface of the core, as in Fig. 158. Fig. 158

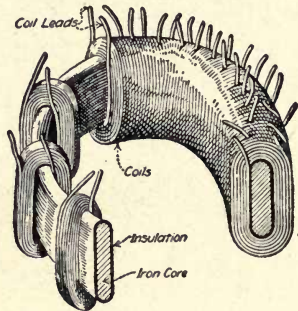

FIG. 157.—Ring armature in section.

shows three coils in place and how the coils fall over one another to form a complete winding, as in Fig. 159. In the drum-type armature the spread of the coils—that is, the number of slots spanned by a coil—is determined by the number of poles. For example, in Fig. 158 the coils span approximately one-quarter of the core, which would indicate that this armature is intended to operate in a four-pole field frame. In the ring armature the distribution of the winding on the core is the same, irrespective of the number of poles,

where in the drum armature the coil spans approximately the distance between the centers of adjacent poles.

Although there is no difference in the two types of armatures so far as voltage generation is concerned, when it comes to a consideration of the various elements that take place in the windings, the ring type lends itself much more

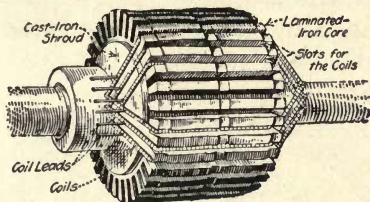

FIG. 158.—Drum-type armature core with three coils in place.

readily to a theoretical discussion, therefore is used in our consideration of this subject.

In the commercial type of machines the armature contains a number of coils. On the small-sized machines the armature is usually wound with a small number of coils having a considerable number of turns of small wire, whereas in the large-sized machines the armature is wound with a

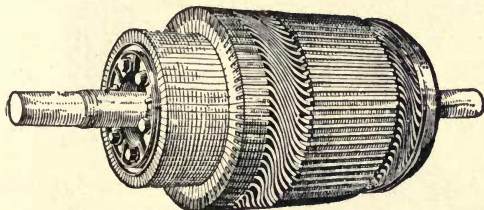

FIG. 159.—Drum-type armature complete.

large number of coils of large wire having a small number of turns, usually one turn made from a copper bar.

Objections to Ring-Type Armatures.—In the earlier type of machines the ring-armature construction was used to considerable extent, but it has since been practically abandoned. Some of the objections to this type of construction are that only one side of the coil is effective in generating voltage.

Why this is so is explained in Fig. 160, where a ring armature is shown between the poles of a two-pole frame. It will be seen that all the lines of force are only cut by the conductors on the outer surface of the core. Therefore, only these parts of the coils are effective in generating voltage.

There is always a leak across the space in the center of the ring; that is, a small percentage of the lines of force, instead of flowing around through the core, take the path

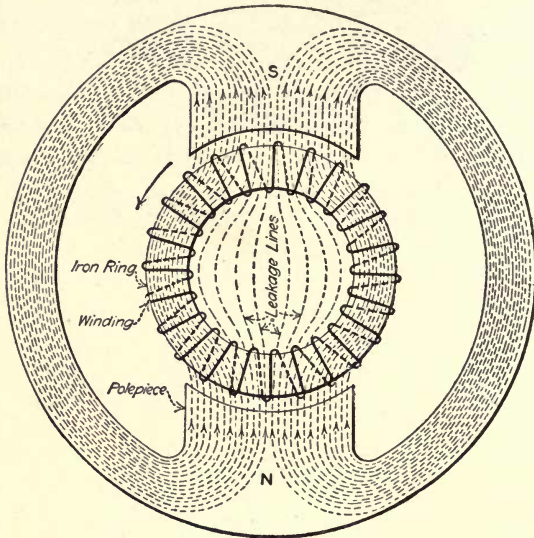

FIG. 16J.—Shows magnetic leakage in ring armature.

across the space in the center of the ring, as indicated in Fig. 160. The conductors on the inside of the ring cut the lines of force that leak across from one side of the ring to the other, in the same direction as the conductors on the outside of the core. Consequently, a voltage will be induced, in the same direction, in the side of the coil on the inner periphery of the ring, as in that on the outer.

In Fig. 160 consider the ring revolving in the direction of the curved arrow; then under the N pole the voltage in both sides of the coils is up through the plane of the paper, and

under the S pole it is away from the reader. In either case it is evident that the voltages generated in the conductors on the outside and inside of the ring oppose each other. Since only a small percentage of the flux leaks across the ring, only this percentage will be cut by the conductors on the inner periphery, and the voltage generated in these conductors will be only a small percentage of that in the outside, the difference between the two being the effective voltage in the coil. The foregoing is another objection to the use of a ring armature.

Another difficulty is in winding the coils on the core, they have to be wound in place by hand. On account of having to thread the coils through the center of the core, the placing of the winding is a somewhat long and tedious job. These and other structural and electrical defects have caused this type of construction to be practically abandoned in favor of the drum type of armature.

Drum-Type Armatures.—The core of the early types of drum armatures consisted of a cast-iron cylinder keyed on a shaft, as in Fig. 161. Pieces of fiber were placed in small

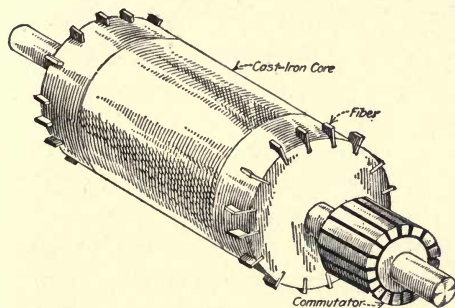

FIG. 161.—Smooth core for drum-type armature.

slots in the corner of the core, as shown, to facilitate the spacing of the coils around the periphery. One of the serious objections to the use of solid cast-iron cores was that they had heavy current generated in them, which not only greatly increased the temperature for a given load, but also loaded up the machine.

The foregoing will be understood by considering Fig. 162, which shows an iron core between the N and S poles of a magnet. If the cylinder is revolved in the direction of the curved arrow, then the side of the core under the N pole will be cutting lines of force in a right-hand direction and will have a voltage induced in it that will tend to cause a current to flow toward the reader. On the other hand, the side of the cylinder under the S pole is cutting the flux entering the pole in a left-hand direction, and consequently has a voltage induced in it that will tend to cause current to flow away from the reader. This is just what we found out about a

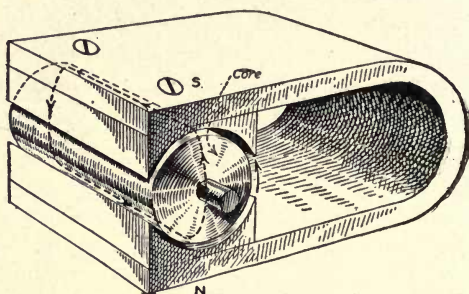

FIG. 162.—Shows how eddy currents are generated in armature core.

loop of wire revolved between the poles of a magnet in Chapter X.

The condition in Fig. 162 is such that the voltage generated in one side of the core is assisting that in the other side. Consequently, a current will flow around in the core, as indicated by the dotted loop and arrowheads. This current is entirely independent of the winding on the armature and external circuit, and just as long as the field poles are excited and the armature revolved, a current will circulate or eddy around in the core. Since these currents circulate or eddy around in the core as water in a whirlpool, they are called eddy currents.

Effects of Eddy Currents.—These eddy currents represent a distinct loss, not only in capacity, but also in the power used to drive the generator or motor. Eddy currents increase the temperature of the machine, consequently

reduce the useful temperature range. For example, if the normal no-load temperature of the armature, if eddy currents did not exist, is 80 deg. F., and the maximum temperature that the machine can be operated at is 212 deg. F., then the machine can be loaded to the extent that would increase the temperature from 80 to 212 deg. F., or 132 deg. But on the other hand, suppose that the no-load temperature of the armature, due to eddy currents, is increased to 100 deg. F.; then the machine is only capable of carrying a useful load that will increase the temperature from 100 to 212 deg. F., or 112 deg. Consequently, the useful capacity of the machine under the latter conditions will be reduced.

It should be kept in mind that the amount of load that can be carried by any electrical machine is limited by the heating effect of the load. For a machine insulated with fibrous material this temperature must be limited to about 212 deg. F.

Another effect of eddy currents in the armature is to increase the power necessary to drive the machine. This will be understood by referring to Fig. 162. Here the generated current due to the core revolving in the magnetic field in the direction indicated by the curved arrow is indicated by the dotted loop and arrowhead in the core. Current flowing in the magnetic field will cause a pull to be exerted upon the core, just as explained for a single conductor carrying a current in a magnetic field in Chapter X.

The direction of the pull on the core may be determined by the rule for the direction of a motor, or, in Fig. 162, it will be found that the eddy currents in the core will produce a pull against the direction of rotation. In other words, we assume that the core is revolving in the direction of the curved arrow, but the direction of the eddy currents in the armature core produces a pull in the opposite direction. Consequently, the source from which the armature is driven will have to develop power enough not only to drive the armature to supply its useful load, but also to overcome the effect of the eddy currents in the core.

Eliminating Eddy Currents.—From what we have just seen, it is apparent that, if possible, these eddy currents should be eliminated. This is done to a very large degree by building up the armature core of thin sheets of soft iron or steel, as in Fig. 163. These sheets are from 0.01 to 0.03 in. in thickness. In the early type of machines the oxide on the surface of the sheets was very largely depended on to insulate one from the other. Although this did not completely insulate the disks from each other, it offered considerable resistance to the flow of the current in the core parallel with the shaft. In the modern machines the iron sheets that the core is made of are given a very thin coat of insulating varnish on one side, which practically entirely eliminates the effect of eddy current.

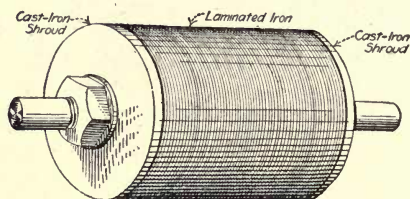

FIG. 163.—Shows how armature cores are built up of thin sheets of iron.

On account of the insulation the core has to be made slightly longer than a solid core would be, in order to get in the same volume of metal. Armature cores that are built up of thin sheets of iron are said to be laminated, and the sheets are frequently referred to as the laminæ. The cores of small-sized armatures are keyed to the shaft and held between cast-iron shrouds, or retaining plates, which are held in place by a nut threaded on the shaft, as in Fig. 163, or by bolts run through the core.

Objection to Smooth-Core Armatures.—With these smooth-core armatures, the winding had to be placed on the surface of the core. There were several objections to this, such as the coils, being on the surface of the core, were exposed to mechanical injury; sufficient space must be allowed between the armature core and polepieces for the winding.

On account of the comparatively long space between the armature core and polepieces, considerably more power is required to be expended in the field coils to cause the lines of force to flow from the latter to the former, or vice versa, than if the core was as near the field poles as would be consistent with good mechanical construction.

Another serious objection is that the coils are wound on the core by hand, one coil at a time. Consequently, the coils can only be removed the reverse of the way they are put on. Therefore, if two or three coils are injured in the winding, it generally means that the whole winding must be removed and a new one put in its place, whereas, if the coils are made up separately, as in modern machines, the injured

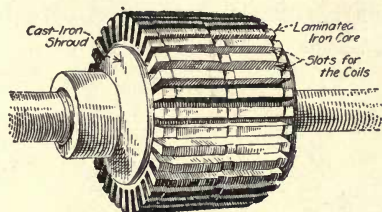

FIG. 164.—Slotted core for drum-type armature.

coils can generally be removed and replaced by new ones, by removing only a small part of the total winding.

All the difficulties cited are practically eliminated by slotting the core as in Fig. 164. The core is built up of thin sheets as in Fig. 163, but instead of the outer periphery of the disk being smooth as in the figure, it has slots cut in it. These slots take different forms, some of which are shown in Figs. 165 to 167. However, when the coils are made up and insulated before they are put on the core, the slots in the core must be open at the top, as in Figs. 166 or 167. Where the coils are made up separately and insulated before placing on the armature, it is evident that the winding is not only more easily put in place, but can be better insulated.

The placing of the coils in slots in the armature core protects them from mechanical injury in case the bearings

wear and allows the armature to rub on the polepieces; it also allows the space between the core and the field poles to be reduced to a minimum consistent with good mechanical

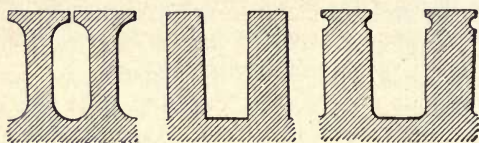

FIG. 165

FIG. 166

FIG. 167

FIGS. 165 to 167.—Different shapes of armature-core slots

construction. Consequently, the magnetic field is set up with a minimum power expenditure in the field coils. In the larger-sized armatures a cast-iron spider, as it is called, is keyed to the shaft and the laminated core built upon the spider, as in Fig. 168.

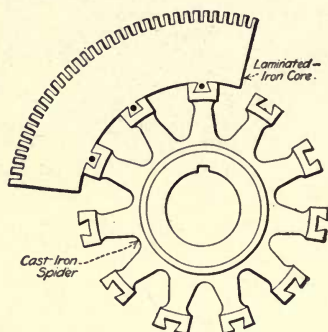

FIG. 168.—Core for large armature built upon a cast-iron spider.

Field Magnets.—The function of the field magnets in an electric generator or motor is to furnish the magnetic field, which in a generator is cut by the armature conductors to generate voltage, and in a motor reacts upon the current flowing in the armature conductors to produce rotation. In the development of the dynamo-electric machine the field magnets have taken on a multiplicity of forms. The field magnets of the earlier types of dynamos were permanent horseshoe magnets, similar to that shown in Fig. 169. Even to-day this type of field pole is used, in some cases, on small

magnetos for ignition, signaling and other purposes. However, this form of magnet was never used on machines of any considerable size, chiefly because the magnets would have to be very large; the strength of the magnets decreases when in use, owing to the vibration of the machine and the effects of the magnetic field set up by the current in the armature winding; also because there is no way of controlling the strength of the field, which is the chief means usually employed for controlling the voltage of the generator or the

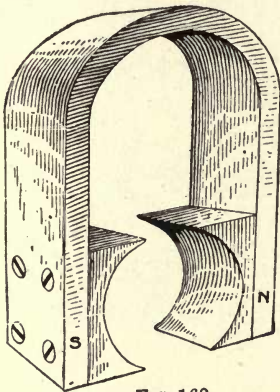

FIG. 169

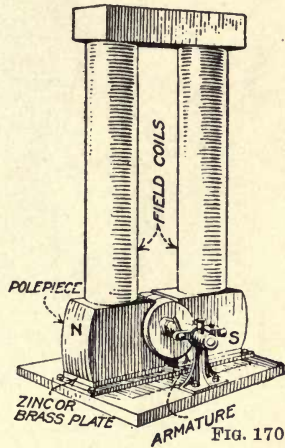

FIG. 170

FIG. 169.—Horseshoe magnet field pole.

FIG. 170.—Edison two-pole dynamo, or motor.

speed of an adjustable-speed motor. These defects soon led to the adoption of electromagnets; that is, coils of wire placed on polepieces of soft iron and excited from some source of electric current.

Early Types of Field Magnets.—Since the permanent-magnet field poles were of the horseshoe shape, it is to be expected that most all of the earlier electromagnets used for field poles were of this form. Fig. 170 shows one of the early types of Edison two-pole machines, and Fig. 171 is a somewhat later and improved type of the same machine. In this arrangement of poles, if they were mounted on an iron

base it would short-circuit the magnetic field; that is, instead of the lines of force passing from the N pole across the air gap, and through the armature core into the S pole, they would take the easier path around through the iron base. To overcome this defect, a nonmagnetic plate of brass or zinc was placed between the polepieces and the baseplate as indicated. To prevent the lines of force from leaking out along the armature shaft down through the bearing pedestals

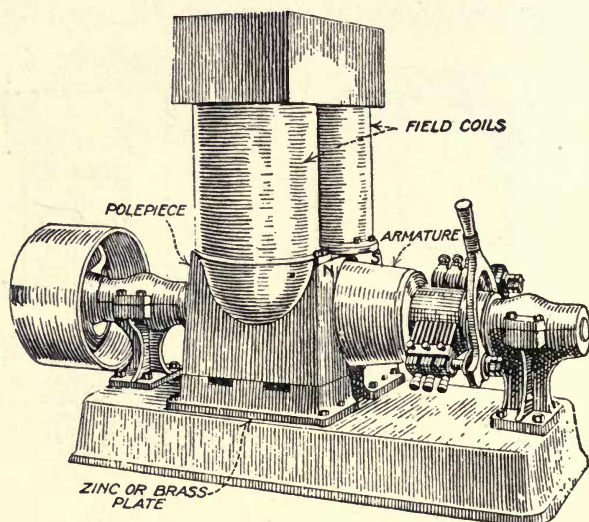

FIG. 171.—Improved type of Edison two-pole dynamo or motor.

into the base of the machine and back into the polepieces, the pedestals were usually made of brass.

To get away from the nonmagnetic bearing pedestal and bedplate, the polepieces were turned upside down with the armature placed in the top, as in Fig. 172. With this arrangement the field magnetism passes from the N pole into the armature through the armature core into the S pole, and down around through the baseplate. Another form of field magnet is that in Fig. 173. This type was usually mounted on a wooden base, for the same reason that the nonmagnetic plate was used in Figs. 170 and 171.

In all the foregoing schemes the flux from the polepieces passes directly from one field pole into the armature, and then to the opposite pole and around through the field structure. Such an arrangement is called a salient-pole machine.

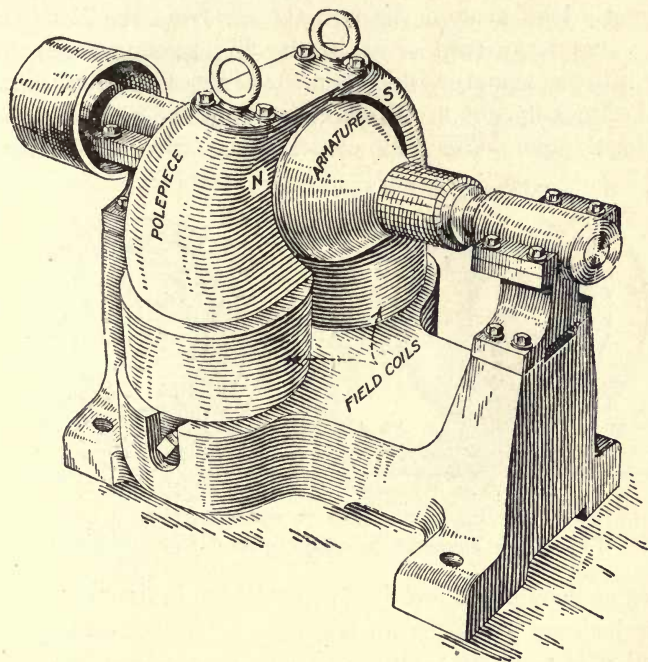

FIG. 172.—Machine with the field poles reversed from that in Fig. 171.

Consequent-Pole Type Machine.—Another type of field pole used in the development of the electric machine is given in Fig. 175. In this construction if the top of one field coil is made north and the other south, the lines of force will flow from the N pole around to the S pole without ever passing through the armature at all. To overcome this difficulty the top ends of both coils are made the same polarity; therefore the bottom ends must also be the same polarity, as shown in the figure. In this arrangement the two N poles oppose each other, and the lines of force must take the next easiest path,

which is down through the armature to the S pole. A machine having a field frame in which like poles oppose each other, so as to cause the flux to pass through the armature, is called a consequent-pole machine. One of the serious objections to this type is that the opposing poles cause a heavy magnetic leak around through the air from the N to the S pole; that is, instead of all of the flux passing from the N pole into the armature and then to the S pole, a large number of the lines fly out in all directions into the air and around to the S pole. This leak constitutes a direct loss. In all

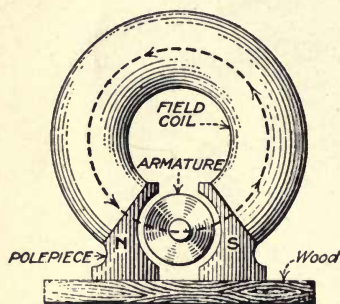

FIG. 173

FIG. 173.—Bipolar dynamo or motor on wooden base.

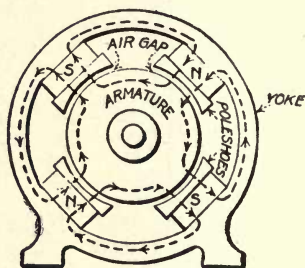

FIG. 174

FIG. 174.—Common type of four-pole dynamo or motor.

types of machines there is always a certain amount of magnetic leakage, but it is much more pronounced in the consequent-pole machine than in the salient-pole type.

Motors or generators with only two poles are called bipole machines; those having more than two poles, that is, four, six, eight, etc., are called multipolar machines. None of the types of field frames so far considered lend themselves readily to multipole construction, consequently very few of these types were developed into multipole designs.

Materials Used in Field Poles.—The arrangements of poles in the field frame that have been exploited could be carried out almost indefinitely, but the one design that is now used almost exclusively is the arrangement shown in Fig. 174. This construction is of the salient-pole type; that

is, there are no opposing poles. This design can be used as readily for bipole as for multipole construction.

All of the earlier field frames and polepieces were constructed of cast iron or steel. In some of the modern types the whole field structure is laminated; that is, built up of thin sheets of iron or steel. Others again have a cast-iron yoke to which laminated pole-pieces are bolted. The yoke is the circular portion in Fig. 174. Other types have cast-iron polepieces with laminated poleshoes. The poleshoe is indicated in Fig. 174. This part is built up of thin sheets of iron or steel and bolted to the cast-iron polepiece.

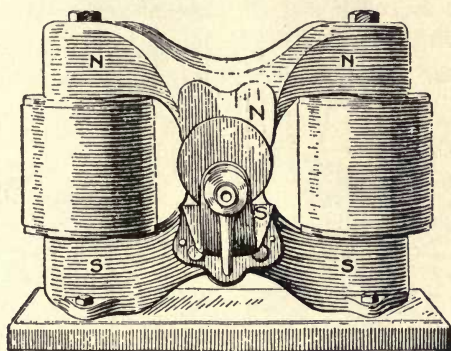

Fig. 175.—Consequent-pole type dynamo or motor.

Function of the Commutator.—In Chapter X it was shown that if a single coil is connected to rings R_1 and R_2 , as in Fig. 176, and revolves between the poles of a magnet as indicated, an alternating current would be caused to flow in the external circuit C . It was also shown that this alternating current could be changed into a current that flows in one direction—that is, a direct current—by connecting the ends of the coil to a divided ring S_1 and S_2 , as in Fig. 177. This divided ring represents the simplest form of what is called a commutator on a direct-current machine. Fig. 177 also represents the simplest form of an armature, one that has only one coil revolving in a two-pole field. In the commercial type of direct-current generators a large number of coils, depending

upon the size of the machine, are arranged on the armature and connected to a commutator.

Commutator Construction.—The commutator is made up of a number of copper segments similar to the one in Fig. 178, each segment being insulated from the other. These segments are slotted in one end, as shown, so that the armature-coil leads may be easily connected. Many of the large-sized commutators have an extension soldered to each segment or bar, as in Fig.

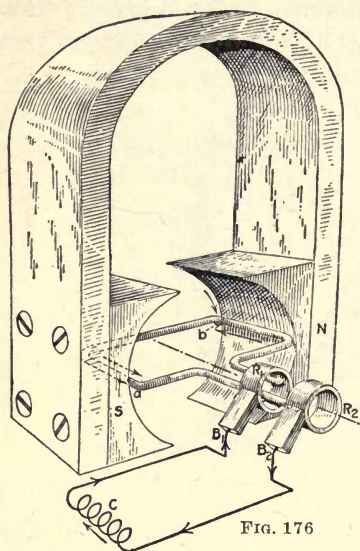

FIG. 176

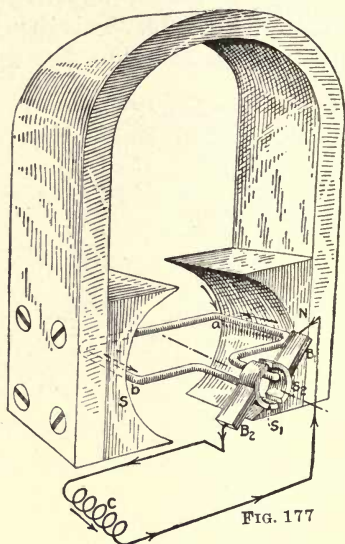

FIG. 177

FIG. 176.—Single-coil alternating-current generator.

FIG. 177.—Single-coil direct-current generator.

179, so that, instead of the coil leads being bent down to the commutator, they are brought out almost on a level with the periphery of the armature.

Fig. 180 shows a section through a common type of commutator. The black lines *A* across the surface are insulation, usually mica, between the segments. The heavy black lines *B* are also insulation, therefore it is evident that each segment is insulated from the iron or steel form. Each division on the commutator is called a bar or segment. The bars and insula-

tion are assembled on the vee and sleeve *C*. Then the front vee, *D*, and its insulation are put in place and the nut *E*, which is threaded on the sleeve *C*, is screwed up as tight as it can be drawn. On account of the expansion and contraction of the commutator, caused by wide variations of temperature and strains due to centrifugal force, it is necessary that the clamping rings hold the bars and insulation very tight, or there will be a movement of the bars that will cause trouble.

The insulation used between the bars is usually mica or micanite, about $\frac{1}{32}$ in. in thickness, and in fact this is the only material that has been found that will stand up under all conditions. Micanite consists of thin flakes of mica built up into sheets and held together by a suitable binder. In some of the small-sized commutators the bars are molded into the

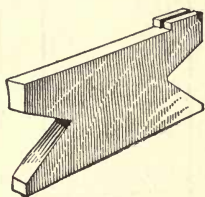

FIG. 178

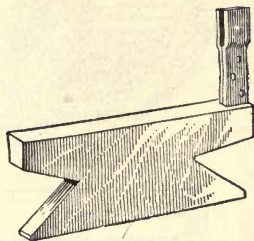

FIG. 179

FIGS. 178 and 179.—Types of commutator bars.

metal sleeve with an insulating compound. This construction for small-sized machines seems to give satisfactory results. In the early development of the art various materials were tried for insulating commutators, such as red fiber, fish paper, asbestos, etc., and various combinations of these materials and also mica and other insulations built up in alternate layers, but all have been discarded.

One of the troubles with most of the substitutes for mica insulation in commutators is, they are easily eaten away in case of sparking at the brushes. Furthermore, all fibers or papers are subjected to more or less contraction and expansion due to moisture conditions. This eventually led to slight looseness between the bars and insulation, so that oil or copper and

carbon dust could penetrate and cause pitting of the commutators. One of the chief requisites of a commutator insulation is that it shall not be affected by moisture and changes of temperature; also, it must possess a certain elasticity so that it

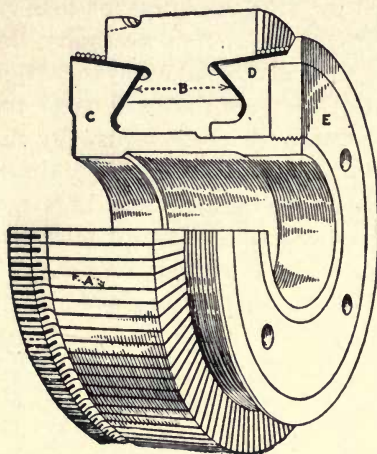

FIG. 180

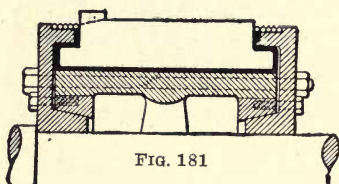

FIG. 181

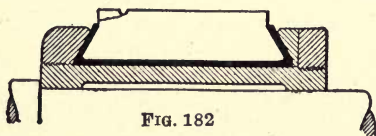

FIG. 182

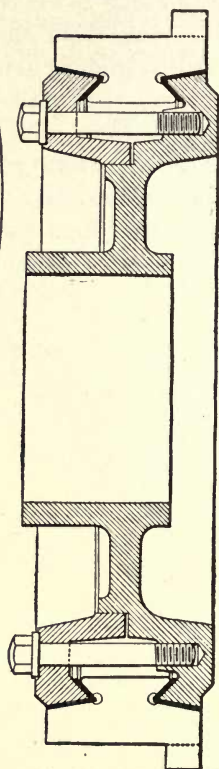

FIG. 183

FIGS. 180 to 183.—Types of commutators.

will fill the space between the bars irrespective of the expansion and contraction of the commutator. So far, mica seems to possess these requirements to a greater extent than anything else. The story of commutator insulation is one of the most interesting chapters in the history of electrical development.

Many other kinds of commutator construction are used, especially in the older types of machines, besides that shown in Fig. 180, some of which are indicated in Figs. 181 and 182, from which it is seen that the general principle is the same. In the larger-sized machines the commutators are built upon a cast-iron spider, the same as the armature core. Fig. 183 shows a cross-section of a large commutator that is representative of large-sized construction.

CHAPTER XII

INDUCTANCE AND COMMUTATION

Magnetic Field About a Conductor.—It has already been learned that when an electric current flows through a conductor, the former causes a magnetic field to be set up about the latter. This magnetic field takes the form of concentric circles, as shown in Figs. 184 and 185. The direction of the



FIG. 184

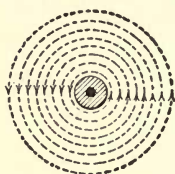

FIG. 185

FIGS. 184 TO 185.—Magnetic field about an electric conductor.

magnetic field is determined by the direction of the current. The cross in the center of the conductor indicates that the current is assumed to be flowing away from the reader, and for this direction of current the magnetic field revolves in the direction indicated by the arrowheads. If the direction of the current is reversed as in Fig. 185, the direction of the magnetic field is reversed, as shown.

How Voltage Is Induced in a Conductor.—This magnetic field seems to emanate from the center of the conductor and has an increasing diameter as the current increases. Fig. 186, *a*, *b*, *c*, and *d*, illustrates the idea. At *a* is represented the effect that would be obtained with a small current flowing in the conductor; at *b*, *c*, and *d*, the successive developments of the magnetic field as the current increases. When the current decreases in value, the reverse effect is true; that is, the mag-

netic field will die down, as illustrated by *d*, *c*, *b*, and *a*, Fig. 186. This increasing and decreasing diameter of the magnetic field about a conductor as the current increases or decreases in value creates an electromotive force in the conductor itself and other conducting material in close proximity to the

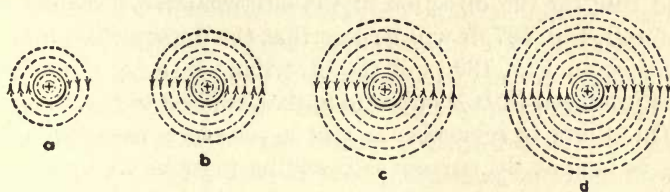

FIG. 186.—Shows how magnetic field builds up about an electric conductor.

former. In Chapter X we found out that an electromotive force was produced in a conductor by moving it across a magnetic field, or when the magnetic field was moved so that the conductor cut across the lines.

Consider two conductors placed close to each other, as in Fig. 187, *b*, with a current flowing through one of them as

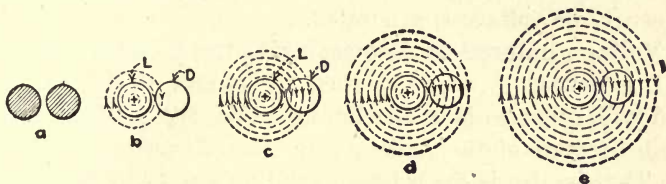

FIG. 187.—Illustrates mutual inductance.

indicated by the cross. As the current increases in value, the diameter of the magnetic field also increases, until the current reaches a normal value, as illustrated by *b*, *c*, *d*, and *e*. The magnetic field of the live conductor *L* is expanding to the right by the dead conductor *D*. This is equivalent to moving conductor *D* to the left across the magnetic field of conductor *L*, which gives the conditions for generating an electromotive force; namely a conductor cutting a magnetic field.

The next thing to consider is the direction of the electromotive force developed in conductor *D*. This is illustrated in

Fig. 188. It has already been seen that the magnetic field of conductor L expands in a right-hand direction by conductor D , which is equivalent to moving the conductor in a left-hand direction, as indicated in Fig. 188; also that the lines of force are in a downward direction. Then by applying the right-hand rule for the direction of the electromotive force in conductor D , Fig. 187, it will be seen that the fingers will point as indicated in Fig. 188, and the direction of the electromotive force produced in D is opposite to that applied to L .

One thing to remember is that a voltage is produced in D only as long as the current is changing in value in L ; as soon as the current reaches a constant value the lines of force also reach a constant value, cease expanding and are therefore no longer cut by conductor D , although conductor D is in the magnetic field when the current has reached a constant value, there is no relative motion of the former across the latter. There is, however, a motion of the lines of force downward by conductor D , but this is only equivalent to moving the conductor upward parallel with the lines of force and therefore does not cut the magnetic field, but simply moves in it; consequently no voltage is generated.

Voltage Induced by Decreasing Current.—If the current in L is caused to decrease, then the circles of the magnetic field will decrease in diameter, and this will produce a left-hand direction of the magnetic line in reference to conductor D . That is, if e is the original condition and the current decreases to zero, a , Fig. 187, will show the condition when the current has ceased to flow. From e to a the lines of force have been contracting in a left-hand direction past conductor D . This would be equivalent to moving the conductor in a right-hand direction across the magnetic field. The equivalent condition is shown in Fig. 189, and by applying the rule for determining the direction of the voltage when the direction of the lines of force and equivalent direction of the conductor are known, the voltage produced in D when the current in L is decreasing, will be seen to be in the same direction as that in L , as indicated in Fig. 189.

Mutual Inductance.—What we have just seen is that when the current is increasing in conductor L , it produces a voltage in conductor D opposite to that in L , and when the current is decreasing in L , it produces a voltage in D having the same direction as that in L . This voltage is produced by what is called “mutual inductance,” and the voltage is said to be induced in D by “mutual inductance.” This is the principle of the induction coil and alternating-current transformer. What has been shown is that two coils with no electrical connection between them may have a voltage and current set up in one by passing a current that is changing in value through the other. When direct current is used, the current is varied in value by breaking and making the circuit.

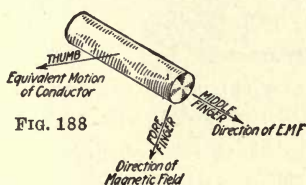

FIG. 188

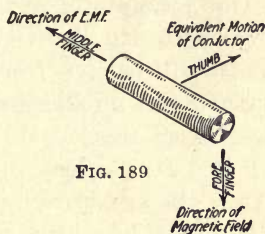

FIG. 189

FIGS. 188 to 189.—Rule for determining direction of induced voltage.

Self-Inductance.—Another thing to consider is the effect of the magnetic field on the conductor itself. It has already been pointed out that the lines of force seem to emanate from the center of the conductor and expand outward. If this is true, it is at once evident that the conductor cuts the lines of force as they expand from the center to the outside of the wire. On the right-hand side of conductor L , Fig. 187, b to e , the lines of force are expanding in a right-hand direction, which would be equivalent to moving the conductor to the left. In other words, conductor L is cutting the lines of force in the same direction, just as a second conductor in close proximity to L , as already explained. Since the foregoing is true, the wire carrying the current will have an electromotive force induced in it in the same direction as a second conductor in

close proximity to the first, and from what has been shown in Figs. 188 and 189 the direction of this voltage is opposite to the applied electromotive force when the current is increasing in value and in the same direction as the applied electromotive force when the current is decreasing in value. Or in other words, this voltage induced in the conductor carrying the current opposes any change in the value of the current. The voltage induced in the conductor is said to be produced by "self-inductance" and, like mutual inductance, can take place only when the magnetic field is changing in value. The effects of mutual and self-inductance enter into electrical problems under a great many conditions, therefore it is important that the principle explained in the foregoing be firmly fixed in the mind. One example of self-inductance is found in the coils under commutation on the armature of a direct-current machine, as will be seen from the following:

Neutral Point on Commutator.—In Fig. 190 the lines of force pass from the N pole into the armature core between points *B* and *D*; likewise under the S pole the magnetic flux passes from the armature core into the S pole between points *A* and *C*. It is only between these points that the armature conductors will be cutting the lines of force and therefore generating voltage, when the armature is revolved. Between points *A* and *B* on the left-hand side of the armature and *C* and *D* on the right-hand side, the conductors are outside of the magnetic field and are not cutting the latter; therefore do not produce any voltage. The space between the polepieces where the conductors do not cut any line of force is called the neutral point or neutral zone. It is always at this point that the brushes must be located on the commutator, because if they are very far off the neutral, serious sparking will result.

In general it is possible to shift the brushes slightly ahead of the neutral, that is, in the direction that the armature is turning, or to shift them slightly back of the neutral, against the direction of rotation, without seriously interfering with the operation of the machine. In some cases the brushes can be shifted slightly ahead or back of the neutral with beneficial

effect upon the operation of the machine, as will be explained later in this chapter.

We have already seen in Chapter X how a ring divided into two parts acts to cause an alternating current generated in a coil revolving between the poles of a magnet to flow in one direction in the external circuit. It will be recalled that, although the current was caused to flow in one direction, the current was of a pulsating nature; that is, flowed in waves.

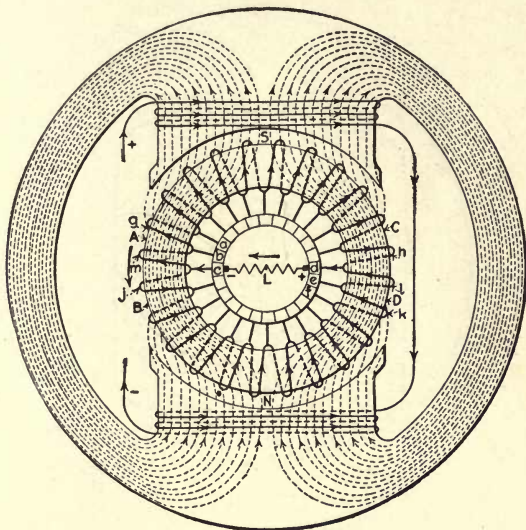

FIG. 190.—Ring-armature type generator.

Where a number of coils are connected to a commutator, as in Fig. 190, the current not only flows in one direction in the external circuit, but also is maintained at a constant value. This will be seen by considering what takes place at the brushes as the armature revolves.

How Voltage in Armature Is Maintained Constant.—In Fig. 191 the armature is shown after it has been revolved one segment from the position shown in Fig. 190. In Fig. 191 coil *k*, which was under the N pole in Fig. 190, has moved out from under the pole and into the neutral zone, while coil *j*, which is

in the neutral zone in Fig. 190, has moved in under the N pole, thus maintaining the same number of active conductors under this pole. The same thing has happened under the S pole, where coil *g*, which is under this pole in Fig. 190, has moved out into the neutral zone and coil *h* has come in under the pole, thus maintaining the number of active conductors under this pole constant and consequently maintaining the voltage at the brushes constant, which in turn will cause a current of

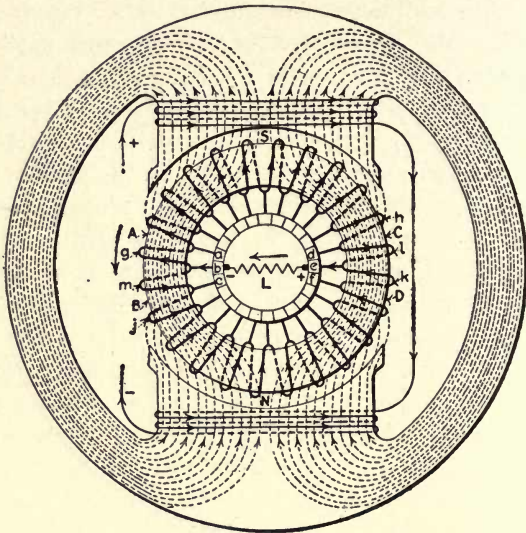

FIG. 191.—Same as Fig. 190; armature turned one commutator segment.

constant value to flow in an external circuit *L* of constant resistance. This is the process that is going on all the time in the armature as long as it is revolved. As fast as one armature coil moves out from under a polepiece, another moves in to take its place, thus maintaining the number of active coils on the armature constant.

The process that takes place around the coils under commutation, that is, the coils in the neutral zone, is one of the most complicated operations in the machine. In Fig. 190 the current in coil *l* is flowing up through the plane of the paper

and to the positive brush. At the negative brush the current is flowing from segment *c* to coil *m* and down through the plane of the paper. In Fig. 191 the current in coil *l* is flowing down through the plane of the paper and to segment *e* and then to the positive brush, and at the negative brush the current is flowing in through segment *b* and to coil *m*, up through the plane of the paper. From this it is seen that the direction of the current in coils *l* and *m* is reversed in Fig. 191 from

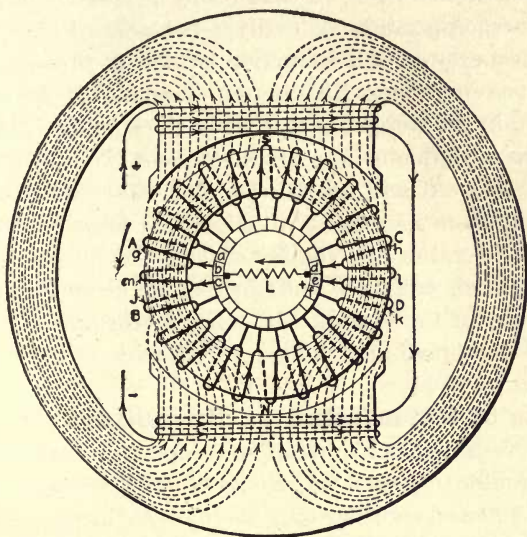

FIG. 192.—Same as Fig. 190; armature coils short-circuited by brushes.

that of Fig. 190. In other words, when the armature revolves through an arc equal to the width of a commutator segment, that is, causes one segment to move out from under a brush and another to move in, the current in a coil connected to the segments that the brushes rests on is reversed.

In changing from the condition in Fig. 190 to that in Fig. 191, there was a period when coils *l* and *m* were short-circuited; this is shown in Fig. 192. In this case the positive brush rests on segments *d* and *e* and the negative brush on segments *b* and *c*. When the brushes are in this position, as

far as the circuits in the armature are concerned there need not be any current flowing in coils l and m , since as shown in the figure, the current to the positive brush can flow directly from coils h and k without flowing through coil l . Likewise at the negative brush, the current is from the brush to coils g and j without passing through coil m . In other words, coils m and l are shuted out of circuit, until the brushes move onto segments b and e , as in Fig 191, where the current must flow in an opposite direction, in coils l and m , to that in Fig. 190.

The foregoing might be easily accomplished if it were not for the property of self-induction, which is present in every electrical circuit when the current is changing in value. It was shown in the foregoing that when the current is increasing in value in a conductor, the conductors cut the line of force set up by the current and induce a voltage that tends to prevent the current from increasing in value, and when the current is decreasing in value, the conductors cut the line of force in a direction which creates a voltage that tends to keep the current flowing in the circuit. In other words, the effect of induction is to oppose any change in the value of the current in the circuit.

Effects of Self-induction on Commutation.—Let us see what the result of self-induction is upon the armature coils under commutation, such as coils l and m in the figures. Start with Fig. 190 and consider only the positive brush. The brush moves off segment d onto segment e bridging across the insulation between the two segments, as in Fig. 192. If it were not for the induction of the coil, there would be no reason for the current flowing in coil l , Fig. 192, but when the coil is short-circuited and the current starts to decrease, it is prevented from doing so by induction and for a short period must continue to flow through the coil into segment d . If this continues until segment d moves out from under the brush and segment e moves in, as in Fig. 191, then the current must not only cease flowing from coil l to segment d , but also reverse its direction and build up to full value in the opposite direction, as in Fig. 191. In the latter case induction again tends to prevent the

current from building up in the opposite direction. The result of this is, if some means, which will be considered later, is not employed to make the current reverse in the coil under commutation in the time required for the brush to pass from one segment to another, severe sparking at the brushes will take place. This is caused by the current not being able to reverse in the coil, in the time that the brush passes from one segment to another, and follows the brush across the insulation between the segments, similar to the way the spark is produced in a make-and-break ignition system on a gas engine. Another thing is that as segment *d* moves out from under the brush, the contact between the brush is getting smaller all the time until the brush leaves the segment. If considerable current is kept flowing from the coil under commutation into the segment that the brush is leaving, such as coil *l* to segment *d*, Fig. 192, it may increase the temperature of the trailing corner of the brush to the point where it will glow.

Commutation Period Short.—The time during which the current must decrease from full value to zero and build up to full value in the opposite direction is very small. For example, assume that the armature in the figure is revolving at 1,500 r.p.m., which is not an excessive speed. Since there are 24 segments in the commutator, $24 \times 1,500 = 36,000$ segments pass each brush per minute, or 600 segments per second. We have just seen that each time a segment passes a brush, the current reverses in a coil. Therefore, when a two-pole armature having 24 segments revolves at 1,500 r.p.m., the current must reverse in the coil under commutation in $\frac{1}{600}$ part of a second. From this it is evident that it may be a somewhat difficult proposition to make the current properly reverse in the coil in such a short period.

At the positive brush the current is flowing up through the coil under commutation and must be reversed and caused to flow down, each time that a segment moves out from under the brush and another one moves in. What would help to reverse the current would be an electromotive force induced in the coil opposite to the direction that the current is flowing in the

coil under commutation; that is, if the current is up through the plane of the paper, the voltage will have to be downward to assist in changing the direction of the current. In the figure all the conductors under the S pole have an electromotive force induced in them down through the plane of the paper. Therefore, if the brushes are shifted so that the positive brush will come under the tip of the S pole, as in Fig. 193, the coil under commutation will have a voltage induced in it that is

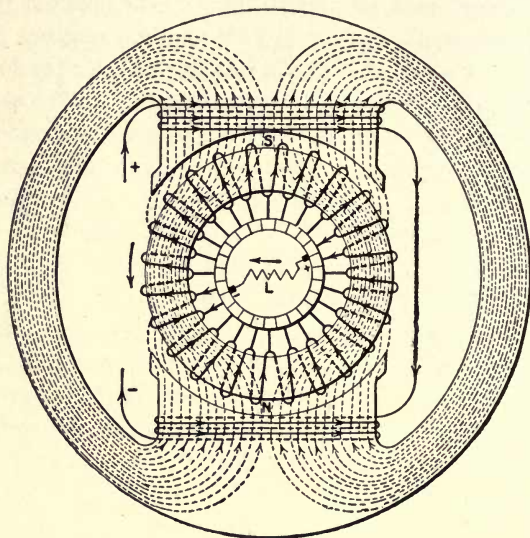

FIG. 193.—Same as Fig. 190; brushes shifted to improve commutation.

opposite to the flow of the current in the coil. When the brushes are properly located, they will be in a position where the voltage generated in the coil will be just sufficient to reverse the *current during* the period of commutation.

The foregoing is one way to obtain sparkless commutation and was the one usually relied upon in the early type of machines, but by improvement in design it has become possible to build generators and motors that will operate over their entire range from no load to full load with the brushes located exactly between the polepieces without sparking. It will be noted

that the brushes are shifted in the direction in which the armature is revolving. However, this is true only of a generator.

When we consider the electric motor, it will be found that the brushes must be shifted against the direction of rotation, to assist in reversing the current in the coil under commutation.

CHAPTER XIII

TYPES OF DIRECT-CURRENT GENERATORS

• **Exciting Field Coils of Direct-Current Generators.**—In previous chapters we considered that the field coils of the generator were excited from an outside source; that is, as in Fig.

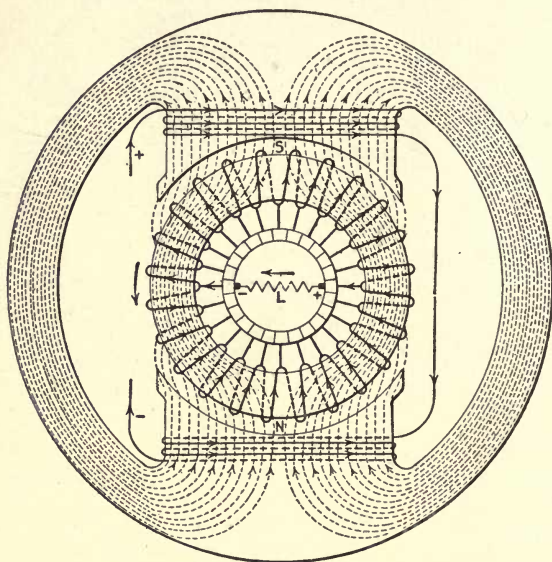

FIG. 194.—Separate-excited shunt generator.

194, the field coils are assumed to be connected to some source of electric current, for exciting them, separate from the armature. In alternating-current generators the field coils are always excited from a separate source of direct current, but in direct-current generators the field coils are in almost all cases excited directly from the armature. There are two ways of doing this, one by connecting the field coils directly across the

brushes—that is, the field winding is in parallel with the armature, as in Fig. 195—and another by connecting the field coils in series with the armature, as in Fig. 196.

When the field coils and armature are connected in parallel, as in Fig. 195, the machine is known as a shunt-connected generator; when the field coils and armature of a generator are connected in series, as in Fig. 196, it is known as a series machine. The shunt-type machine, or modifications of it, which will be considered later, is the type that is generally used, the straight series type being seldom used and then in only special cases. To simplify the connection in Fig. 195 and subsequent figures, the commutator will be shown on the outside of the winding and the yoke will be dispensed with.

Residual Magnetism.—With the machine that excites its own field coils, the first question that arises is, How does the machine start to generate? If the machine were new and never had been in service before; it would not generate until an electric current had been caused to flow through the field coils to magnetize the polepieces. When the field poles have been magnetized, they will retain a small percentage of the magnetism after the current has ceased to flow through the field coils. This generally amounts to about 5 per cent of the normal field magnetism. The magnetic flux which remains in the field poles after the current has ceased to flow in the coils is called the residual magnetism. This residual magnetism is sufficient in a 110-volt machine to cause about 5 or 6 volts to be generated in the armature when running at normal speed and with the field coils disconnected from the armature, as in Fig. 197; in a 220-volt machine, approximately 10 or 12 volts will be generated due to the residual magnetism.

How Voltage Is Built up in the Armature.—If the field coils are connected across the armature, as in Fig. 195, and the latter revolves in the direction of the curved arrow, a small voltage will be, as pointed out in the foregoing, generated in the armature windings. This small voltage, say 5 volts, will cause a small current to flow through the field windings; if in the proper direction, it will cause the field strength to be in-

creased above that of the residual magnetism and result in an in voltage.

In Fig. 195 the polarity of the residual magnetism is denoted by N and S , which will, for the direction that the armature is turning in, cause the right-hand brush to have positive and the left-hand brush negative polarity. This in turn will cause a current to flow through the field coils in the direction indicated by the arrowheads. By applying the rule for the polarity of a coil of wire with an electric current flow-

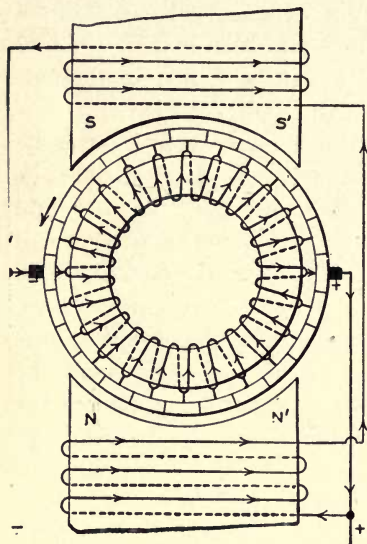

FIG. 195.—Shunt-type generator.

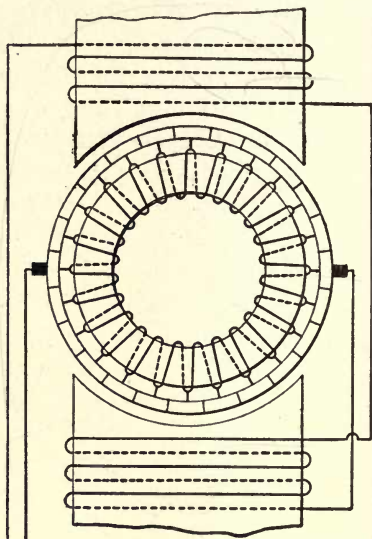

FIG. 196.—Series-type generator.

ing through it, it will be found that the field coils will have a polarity as indicated by N' and S' , which will be seen to be the same as the residual magnetism in the polepieces. Consequently the current flowing in the field coils will assist in magnetizing the polepieces, and the small current set up in the field coils by the 5 volts, which we assumed was generated due to the residual magnetism in the polepieces, will increase the field strength; that is, there will be a greater number of lines of force entering and leaving the armature. The armature

will therefore be cutting a greater number of magnetic lines, hence causing the voltage to increase, which in turn will cause the field current to increase, thus bringing about another increase in the field flux and also the voltage in the armature. This process continues until the machine is generating full voltage.

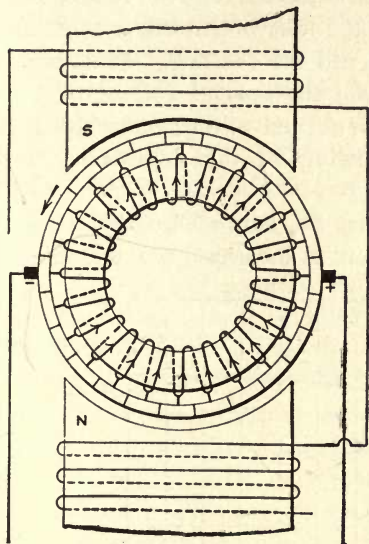

FIG. 197

FIG. 197.—Same as Fig. 195; field winding disconnected.

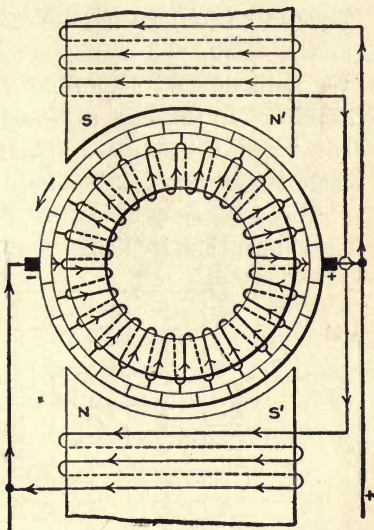

FIG. 198

FIG. 198.—Same as Fig. 195; field connections reversed.

Lines of Force in Field Poles Does Not Increase in Proportion to the Current Flowing in the Field Coils.—The next question that naturally arises is why this process does not keep on indefinitely and the voltage continue to increase in value. The answer to this is found in the fact that the lines of force in the field poles do not increase in proportion to the current flowing through the coils.

If we were to take a generator with the iron in the magnetic circuit absolutely dead, that is, no residual magnetism in it, and connect a voltmeter across the armature terminal and

drive the machine at normal speed, it would be found that the voltmeter would give no reading, indicating that no voltage was being generated. However, if the field coils are connected to a separate source of voltage and a small current caused to flow through the field coils, say 0.2 ampere, we would find that the generator would produce an electromotive force of, say 90 volts. Then if we were to increase the current to 0.4 ampere, it would be found that the voltage may not increase as much for the second 0.2 ampere as it did for the first. This, however, will depend somewhat upon the normal voltage of the machine. In this case assume the normal voltage to be 110 and that when 0.4 ampere was flowing in the field coils, the machine generated 115 volts.

The foregoing is indicated on the curve Fig. 199. Here it is shown that if the field current is increased to 0.6 ampere,

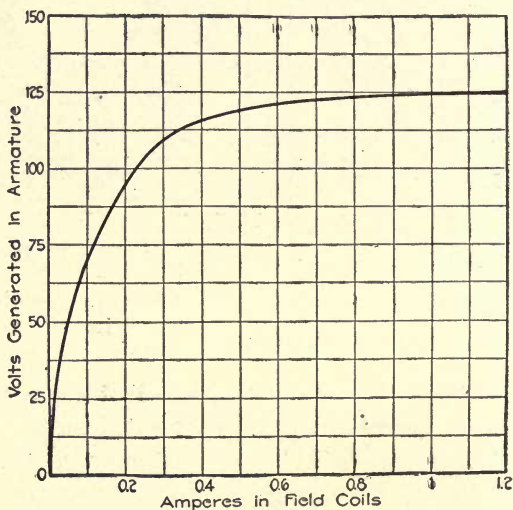

FIG. 199.—Direct-current generator voltage curve.

the volts will only increase to about 120, and beyond this point if the current is increased to 1.2 amperes, the voltage only increases to 124. For the first 0.6 ampere supplied to the field coils the voltage increases from 0 to 120, but for the next 0.6

ampere the e.m.f. only increases from 120 to 124, or an increase of 4 volts. The foregoing indicates that the lines of force in the polepieces increase rapidly at first, but as the current in the field coils increases, a condition is reached beyond which increasing the current in the latter will not cause any increase in the lines of force. This condition is called the point of saturation; that is, the iron is saturated with magnetic flux, just the same as a sponge becomes saturated with water.

Field-Coil Connections and Armature Rotation.—A fixed relation exists between the connection of the field winding to the armature and the direction of rotation. It has already been shown that the field-coil connections to the armature in Fig. 195 are such that the current flows through them from the armature, in a direction to make the field coils the same polarity as the residual magnetism in the polepieces, thus causing the machine to build up to normal voltage. However, suppose we interchange the field-coil connections as in Fig. 198. In this case the polarity of the field coils, as indicated by N' and S' is opposite to that of the residual magnetism, indicated by N and S . Consequently, instead of the small current caused to flow in the field coils by the voltage generated due to the residual flux, increasing the field strength, it has the opposite effect and the machine cannot build up its voltage.

At first thought it may appear that if the polarity of the residual magnetism is reversed, the machine connected as in Fig. 198 could build up. Considering Fig. 200 will show that this is not true. Since the residual magnetism is reversed, as indicated by N and S , the voltage generator in the armature is reversed; consequently, the current in the field coils is also reversed, as indicated by the arrowheads. This again brings the polarity of the field coil, as shown by N' and S' , opposite to that of the residual flux, and the machine cannot build up. Therefore it is evident that for the direction of rotation shown there is only one way that the field coil can be connected to the armature and have the machine generate, and that is as in Fig. 195.

Reversing Rotation of Armature.—If the armature's direction of rotation is reversed, as in Fig. 201, then the field-coil connections to the armature have to be reversed before the machine can build up. Assume the same polarity for the residual magnetism as in Fig. 195; then, since the direction of rotation is reversed in Fig. 201, the voltage generated in the armature winding will be reversed, as indicated by the arrow-heads. This voltage will cause a small current to flow through

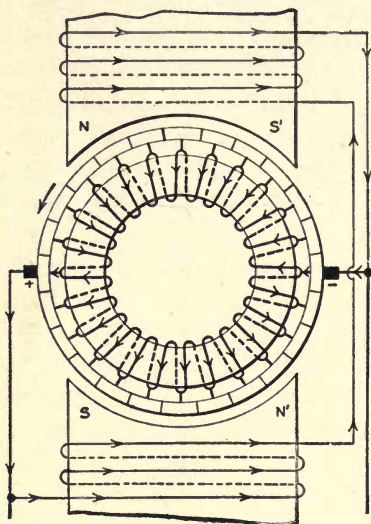

FIG. 200

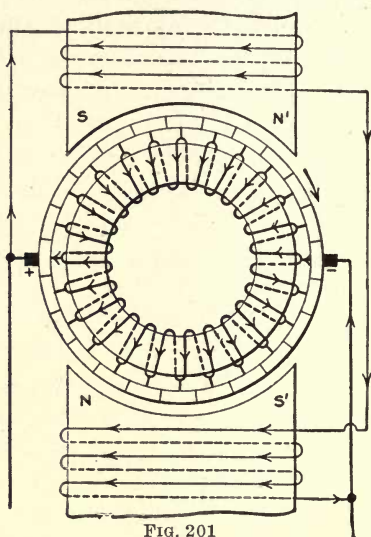

FIG. 201

FIG. 200.—Same as Fig. 198; residual magnetism reversed.

FIG. 201.—Same as Fig. 195; with direction of armature reversed.

the field coils in a direction as shown, which gives the coils a polarity N' and S' which is opposite to that of the residual flux, and the generator cannot build up to normal voltage.

To produce a condition where the machine can build up its voltage it will be necessary to interchange the field connection to the armature terminals, as in Fig. 202. This allows the small voltage due to the residual magnetism to set up in the field coils a current that will give them the same polarity as the residual flux, and the machine will build up normal voltage.

The foregoing is an important point to remember when putting into service a new machine or one that has been repaired. After the field poles have been excited by sending a current through the field coils from an outside source, to establish the residual magnetism, if the machine does not build up, then the shunt-field coil connection should be reversed.

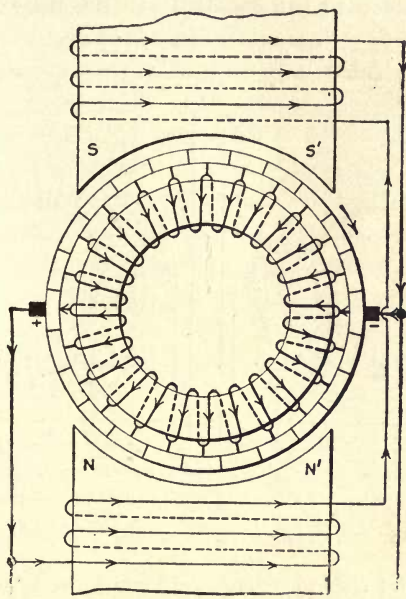

FIG. 202.—Shunt generator rotating opposite from that in Fig. 195, with field coils connected correctly.

One way of knowing when the field coils are connected in the right relation to the armature is as follows: First bring the machine up to normal speed with the field coils disconnected from the armature and note the voltage generated, which should, as pointed out in the foregoing, be about 5 or 6 for a 110-volt machine, 10 or 12 for a 220-volt machine, etc. After doing this connect the field coils to the armature, and if the voltage due to the residual magnetism decreases, the field-

coil connections must be reversed for the machine to come up to normal voltage. For further information on changing the field connections of generators see discussion on Figs. 219 and 220 at the end of this chapter.

Series-connected Generator.—In the foregoing we saw how a shunt generator was capable of building up a voltage from the residual magnetism in the fieldpoles when the field coils are connected to the armature in the proper relation, as

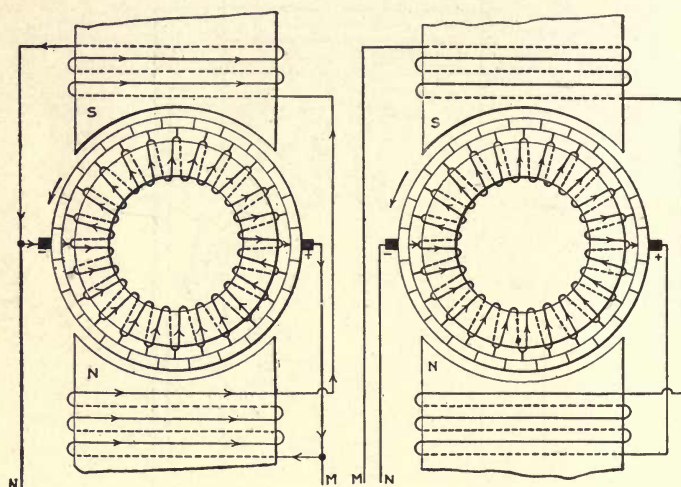

FIG. 203.—Shunt-type generator. FIG. 204.—Series-type generator.

in Fig. 203. In this case the field coils are connected across the armature, therefore the latter is capable of causing a current to flow through the former whether the armature is supplying an external load or not. In Fig. 203 the field circuit is from the positive brush through the field coils back to the negative brush without passing through terminals *M* and *N*, which lead to the external load, hence it is evident that the field circuit of a shunt-type generator is independent of the load circuit.

In the series-connected generator, as in Fig. 204, it will be seen by following around from the brush marked plus through the field coils that in order for the circuit through the arma-

ture and field coils to be completed an external load L must be connected between terminals M and N , as in Fig. 205. In other words, the series generator cannot build up its voltage unless it is connected to a load.

Since the field coils of the series generator are connected in series with the load and armature, it is at once evident that the cross-section of the conductors in the field coils must be large enough to take care of the full-load current of the machine. The field coils on the shunt generator are connected across the armature and are wound with wire of a size that will make the coils of such a proportion as to produce the flux in the pole-pieces with the minimum expenditure of energy. The power required to excite the field coils is generally from about 1 to 3 per cent of the output of the machine.

Ampere-Turns on Field Poles.—To generate a given voltage, the armature must revolve at a certain speed and the magnetic field of the polepieces must have a definite value. To set up the lines of force in the magnetic circuit, it is necessary that a required number of ampere-turns in the field coils, say 6,000, be supplied.

Ampere-turns is the number of turns in a coil of wire multiplied by the current in amperes that flows through it when connected to an electric circuit; that is, if a coil contains 2,000 turns and when connected to a 110-volt circuit, 3 amperes flow through it, then the ampere-turns are $2,000 \times 3 = 6,000$.

If we assume the machine in Fig. 203 to require 6,000 ampere-turns to excite the field coils sufficiently for the armature to generate 110 volts, and further assume that the full-load current of the machine is 100 amperes and requires 3 amperes to excite the field coils, then the number of turns in the field coils will be ampere-turns divided by amperes, or $6,000 \div 3 = 2,000$, and the resistance of the wire in the field coils is volts divided by current, or $110 \div 3 = 37$ ohms approximately.

If the series machine, Fig. 205, is assumed to have the same capacity as the shunt machine, Fig. 203, and requires the same number of ampere-turns to excite the field coils as the shunt machine to generate 110 volts, then the number of turns of wire required in the field coils, since the total current is flowing through the field winding, will be $6,000 \div 100 = 60$ turns, or 30 turns on each coil. Since the total current flows through the field coils and load in series, the combined resistance of the field coils and load can only be volts \div amperes, or in this case, $110 \div 100 = 1.1$ ohms.

Now if we are to keep the amount of power expended in the field coils on the series machine down to approximately that of the shunt machine, or 3 per cent, then the resistance of the field coils can be only 3 per cent of the total resistance, or $1.1 \times 0.03 = 0.033$ ohm, or the resistance of the field coils shunt machine is $\frac{37}{0.033} = 1,121$ times that of the series machine.

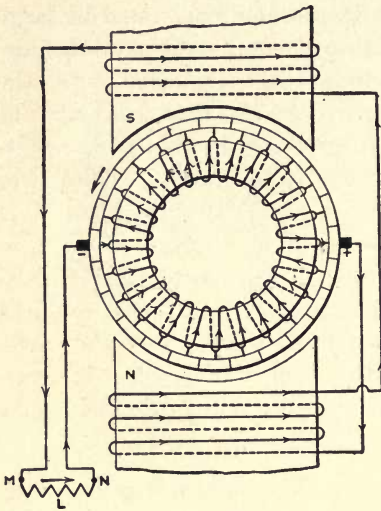

FIG. 205

FIG. 205.—Series generator connected to a load.

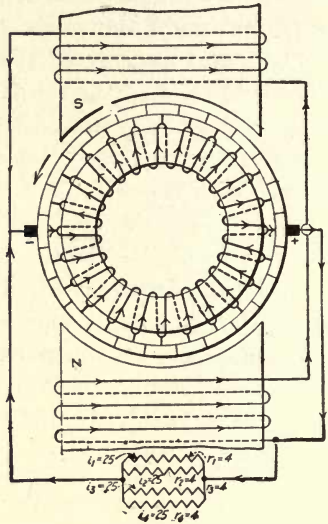

FIG. 206

FIG. 206.—Shunt generator connected to a load.

The foregoing shows the most prominent structural difference between the shunt and series type of machines. The field coils on the shunt machine are wound with a large number of turns of small wire having a comparatively high resistance and are connected in parallel with the armature. The field coils of the series machine are wound with a small number of turns of large wire, consequently have a low resistance and are connected in series with the armature. However, the size of the conductors in either case varies with the size and the voltage of the machine.

The comparison of the field coils in the foregoing is not absolutely correct, because, in the first case we assume 110

volts at the brushes and in the series machine we have assumed that the total pressure generated is 110 volts. However, the comparison is close enough for all practical purposes and eliminates a lot of calculation.

It is evident that with the series generator if the field strength is to be maintained constant, consequently the voltage at the brushes at a constant value, the load also will have to be maintained at a constant value. This is generally a difficult thing to do, since the load on a generator is usually made up of a number of different devices used for different purposes and of different sizes and types, which are connected to the circuit when wanted and disconnected when not required. The devices also require approximately a constant voltage for their operation. Such a condition cannot be met very successfully by the series generator.

Load on a Shunt Generator.—From what we have already seen of the shunt generator, it is evident that the load on the machine does not affect the field circuit. For example, in Fig. 206 is given a shunt generator supplying a load of four resistances, r_1 , r_2 , r_3 and r_4 each of 4 ohms, in parallel. If we assume that the armature develops 100 volts and neglecting the effect of the armature resistance, the current i flowing in

each section of the load is $i = \frac{E}{r} = \frac{100}{4} = 25$ amperes, or a total of 100

amperes in the four circuits. If one resistance is disconnected from the circuit, the current supplied to the load will be $25 \times 3 = 75$ amperes, and if only two are connected, the current delivered to the load by the armature is 50 amperes, and for one resistance, 25 amperes. Under any one of the conditions the current flowing in the field coils will remain practically constant since, as shown, this circuit is independent of the load. Consequently, the value of the field current is not affected by the load, except as the voltage is caused to vary slightly by the load current and resistance of the armature. This latter factor will be considered further on in this chapter.

Load on a Series Generator.—Now consider what would happen if we varied the load on the series generator, Fig. 207, the way that it was changed on the shunt generator, Fig. 206. In Fig. 207, if we assume the machine to be generating 100 volts and that 100 amperes is flowing in the circuit, then 100 amperes is passing through the field coils. If one section of

the load was taken off and if the voltage at the armature terminals remained constant at 100 volts, as was assumed in the shunt machine, 25 amperes would flow through each of the three resistance elements, as in Fig. 206. But with the series machine the pressure will decrease since the current has been decreased in the field coils, consequently the current will decrease in the different elements connected across the armature terminals. From this it is evident that as the load is

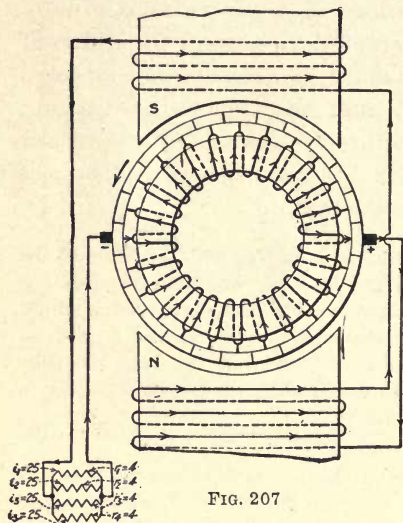

FIG. 207

FIG. 207.—Series generator connected to a multiple load.

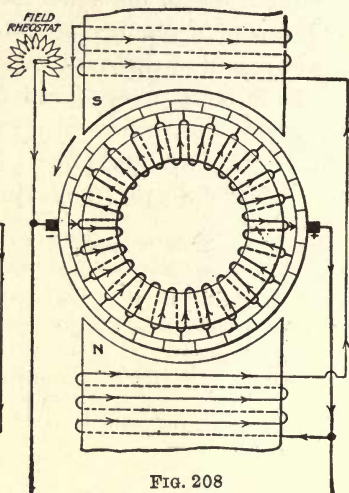

FIG. 208

FIG. 208.—Rheostat in field circuit of shunt generator.

decreased on the series machine the voltage is decreased and the current through each individual load also decreases; whereas, on the shunt generator the total load may be varied, but the current in the individual loads and the voltage remains practically constant.

What we have just seen has practically eliminated the series type of machine from commercial use in preference to the shunt type or modifications of this latter type.

Voltage Control on Shunt Generator.—Direct-current generators are generally designed so that, if the shunt-field

winding is connected directly across the armature, as shown in Fig. 203, they will at rated speed develop about 120 per cent normal volts, that is, a 110-volt machine will generate about 125 or 130 volts. The voltage is then adjusted to normal by connecting an adjustable resistance in series with the field circuit, as in Fig. 208. The current through the field coils is adjusted by means of this resistance so as to produce normal volts. Then any slight variation in the voltage, due to changes in load or otherwise, can be taken care of by varying the resistance in the field circuit. The resistance connected in series with the field coils is called a field rheostat.

Diagrams of Direct-Current Generators.—In Fig. 209 is a diagram of a shunt generator or motor. In this all that is indicated is the circuits; the armature is indicated as a segmental ring and the field winding as a spiral. However, it will be seen that the field circuit in Fig. 209 is in parallel with the armature, as in Fig. 203. In Fig. 210 the field winding is connected in series with the armature as in Fig. 204, making one circuit through the machine in either case. The diagrams, Figs. 209 and 210, provide a convenient means of representing the circuit through electrical machinery, and will be used many times in future chapters.

Effects of Loading a Shunt Generator on Voltage Regulation.—In Fig. 211 the field coils are shown excited from a source separate from the armature, so that any variation in the voltage at the armature terminals will not affect the strength of the magnetic field. Assume that the armature has 0.23 ohm resistance and generates 115 volts on open circuits, as in Fig. 209. Now, if a resistance of $R' = 5$ ohms is connected across the terminals of the generator, as in Fig. 211, the total resistance of the circuit will be R equals that of the armature and external circuit in series, or $R = r + R' = 0.23 + 5 = 5.23$ ohms, and the current that will flow in the circuit is

$$I = \frac{E}{R} = \frac{115}{5.23} = 22 \text{ amperes.}$$

As has been explained in Chapter VI, part of the voltage produced in the armature will be used up in the armature winding to cause the current to flow through this section of the circuit. This voltage e is equal to the resistance of the armature times the current; that is, $e = rI = 0.23 \times 22 = 5.06$ volts. From this we see that when 22 amperes is flowing

in the circuit, there is 5.06 volts drop in the armature winding. Hence the available voltage at the armature terminals is $E_a = E - e = 115 - 5.06 = 109.94$ volts, as shown.

Consider what would be the effect of connecting a second resistance of 5 ohms across the generator terminals, as shown in Fig. 212. The joint resistance of r' and r'' is R' equals one-half that of r' , or $R' = 5 \div 2 = 2.5$ ohms. Then the total resistance of the circuit is the joint resistance of the external circuit and that of the armature winding, from which

$$R = R' + r = 2.5 \times 0.23 = 2.73 \text{ ohms,}$$

and the current

$$I = \frac{E}{R} = \frac{115}{2.73} = 42 \text{ amperes approximately.}$$

To cause the current to flow through the armature will require a voltage $e = rI = 0.23 \times 42 = 9.66$ volts. This will leave a voltage of $E_a = E - e = 115 - 9.66 = 105.34$ volts available at the armature terminals, as indicated.

From what we have seen in Figs. 211 and 212, it is evident that as the load is increased on a shunt generator the voltage at the armature terminals decreases. The voltage generated by the armature would also, to a certain extent, decrease if the field coils are connected to the brushes, as shown in Fig. 209. For the reason that as the voltage decreases across the armature terminals the current will be decreased in the field coils, consequently the number of lines of force will be reduced. In Fig. 211 with a resistance of 5 ohms connected across the armature 22 amperes flowed through the circuit, while in Fig. 212, where two resistances of the same value are connected in parallel, only 21 amperes is sent through each resistance, showing that as the load increases on a shunt generator, unless some means is taken to maintain the voltage constant, the current will decrease in each circuit as more load is connected to the generator.

How Voltage May Be Maintained Constant.—One way of maintaining the voltage practically constant would be to design the generator for about 20 per cent over voltage and connect a rheostat in series with the field winding, as in Fig. 213, to reduce the field current to a value where normal voltage would be generated at no load; then, as the voltage falls off because of an increase in load, sections of the rheostat can

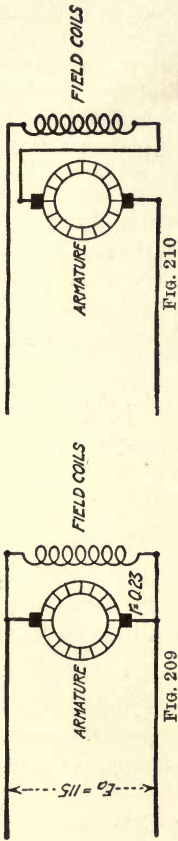

Fig. 210

Fig. 209

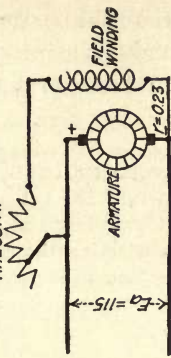

Fig. 211

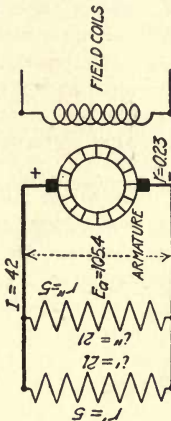

Fig. 212

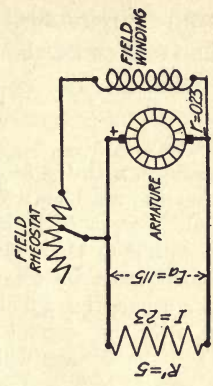

Fig. 213

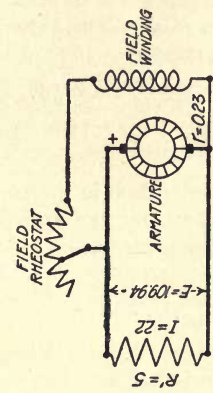

Fig. 214

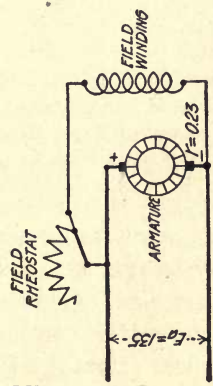

Fig. 215

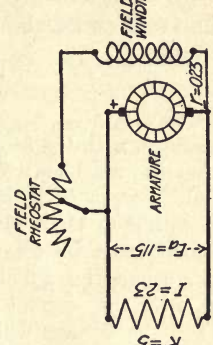

Fig. 216

FIGS. 209 to 216.—Diagrams of shunt-connected and series-connected direct-current machines.

be cut out of circuit so that the field current will increase to a value that will cause the generator to produce sufficient pressure to maintain the voltage at the armature terminals constant.

For example, with the field rheostat cut out of circuit, as in Fig. 214, assume that the machine will generate 135 volts, and with part of the rheostat cut in series with the field windings, as shown in Fig. 213, the voltage decreases to 115. Then, neglecting the effect of the decrease in voltage at the armature terminals, due to increase of load, on the field winding and connecting a 5-ohm resistance across the armature terminals, as in Fig. 215, the current in the circuit will be approximately 22 amperes and the voltage will drop to 109.94, as in Fig. 211. Now to bring the voltage back to normal, some of the field rheostat can be cut out as in Fig. 216. This will increase the current in the field coils and in turn increase the field strength, so that the armature conductors will be cutting a greater number of lines of force and producing a great voltage; as is shown in the figure, the voltage has been increased to normal, or 115.

With 115 volts available at the armature terminals, the current in the external circuit is $I = \frac{E}{R'} = \frac{115}{5} = 23$ amperes, instead of 22, as in Fig. 215, and the volts drop in the armature is $e = rI = 0.23 \times 23 = 5.29$ volts.

Therefore, for the armature to maintain 115 volts at its terminals with a 23-ampere load, it will not only have to generate the 115 volts available at its terminals, but also 5.29 volts to cause the current to flow through the resistance of the windings or a total of $E = E_a + e = 115 + 5.29 = 120.29$ volts.

After the voltage had been adjusted to 115 at the armature terminals with a load of 23 amperes, if the load was taken off and the field rheostat not changed, the voltage would increase to 120.29 volts, or the total of that generated in the armature. Although, in Fig. 216, only 115 volts is available at the armature terminals, nevertheless, the machine is generating 120.29 volts; 5.29 volts is used up in the armature winding. As soon as the load is taken off, there is no current flowing through the winding to use up the 5.29 volts and it becomes available at the brushes. To bring the volts back to normal again it will be necessary to cut the resistance back into the field circuit, as in Fig. 215.

From what we have seen it is evident that if the load on a shunt generator is varying, the voltage will fluctuate according to the load. Of course, these fluctuations, if they do not occur too rapidly, can be taken care of by the operator adjusting the field rheostat. However, a better way of doing this, if

possible, would be to incorporate some automatic means in the construction of the machine to maintain the voltage constant.

Compound-Wound Generator.—In the foregoing we found out that if the load is increased on a series-connected generator the voltage will increase, and decrease as the load decreases. Taking advantage of this fact provides a means of obtaining a close voltage regulation on direct-current generators. This is done by constructing what may be called a combination of a shunt and series machine, or, as it is known, a compound-wound generator. This connection is shown in Fig. 217. From this figure it will be seen that one field winding is connected in series with the armature, as in Fig. 204, and a second field winding connected across the armature, as in Fig. 203. The shunt-field winding provides the flux to generate about 110 to 115 per cent normal voltage, the 10 or 15 per cent excess volts being taken by the field rheostat. The series-field winding sets up the flux necessary to generate the additional voltage to compensate for the volts drop through the armature due to the load current and the resistance of the winding.

In Fig. 217, if the armature is revolved in the direction of the curved arrow, a voltage will be generated in the winding of a polarity as indicated and a current will flow through the shunt-field windings in the direction shown by the arrowheads. This voltage can be regulated to normal by adjusting the field rheostat, or as we will assume, to 115 volts. With no load on the machine no current is flowing through the series-field winding, although some machines are connected so that the shunt-field current flows through the series-field winding.

If a resistance is connected across terminals *M* and *N*, as in Fig. 218, of such value as will allow a current of, say, 25 amperes to flow, as indicated, this current passes through the series-field winding and will increase the number of lines of force entering and leaving the armature, consequently the voltage generated in the armature conductors will be increased. On the other hand, the current flowing through the armature will cause a certain voltage drop in the winding.

Now if 5 volts is required to cause the current to flow through the armature winding, and the series-field amperes-turns cause the magnetic field to increase in value to where the armature will generate 120 volts, then the 5 additional volts will just compensate for the loss in the armature and the volts at the armature terminals will be maintained constant. If the current supplied to the load is increased to 50 amperes, then the current through the series-field winding will increase to 50 amperes, which in turn will increase the number of lines of

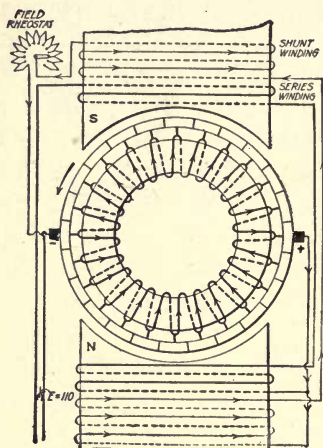

FIG. 217

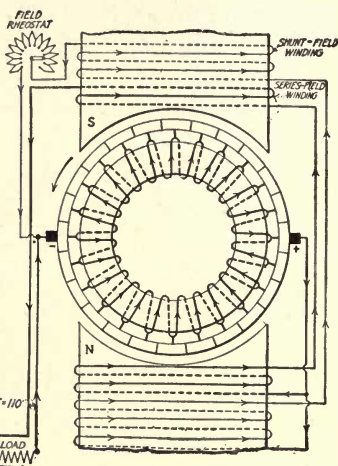

FIG. 218

FIGS. 217 and 218.—Compound-wound generators.

force entering and leaving the armature and again cause the volts generated to build up and compensate for the drop in the armature, thus keeping constant e.m.f. at the brushes.

The foregoing characteristic of the compound generator, which is nothing more nor less than a shunt generator, having in addition to the shunt winding, a series-field winding on its polepieces, to automatically maintain the voltage approximately constant at its terminals, has caused this type of machine, with certain modifications, to be adopted almost universally for generating direct current. Due to the iron in the polepieces becoming saturated, the lines of force do not

increase in proportion to the ampere-turns on the field coils, thus making it impossible to design a compound generator that will maintain absolutely constant voltage from no load to full load. This subject will be discussed in the next chapter.

Crossing Field Connections of Compound-Wound Generator.—In the foregoing it was shown that when the field coils of a generator are connected so that their magnetomotive force opposes that of the residual magnetism in the polepieces, the machine cannot build up its voltage. The statement was made that the remedy for this condition is to “cross the field

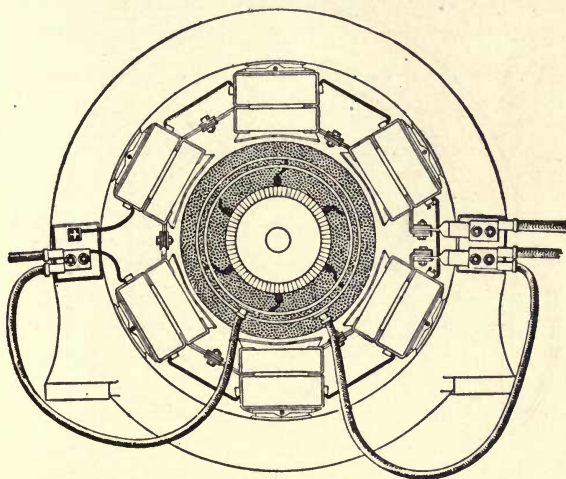

FIG. 219.—Large compound-wound generator

connections.” In a shunt machine this can generally be easily done, and as far as the shunt winding in a compound machine is concerned the foregoing is always true. But in the compound generator, to keep the series winding the same polarity as the shunt, the leads of the former must also be crossed, if this is possible. However, if the machine is of 100-kw. capacity or above, it not infrequently happens that the series-field leads are heavy copper bars brought to terminals, as shown in Fig. 219, which makes it impossible to cross these leads.

If it is necessary to cross the field connections for the machine to build up, the shunt connections can be crossed and

the generator will come up to voltage, but if the field windings are in opposition when the load is thrown on, the voltage will decrease very rapidly as the load increases, owing to the demagnetizing effects of the series-field winding.

It may be possible to cross the armature connection instead of the field. If this can be done, the machine will come up to voltage and the field windings will have the correct polarity. But at best this generally results in a bad arrangement of the leads around the brush gear, and in many cases the armature leads cannot be crossed.

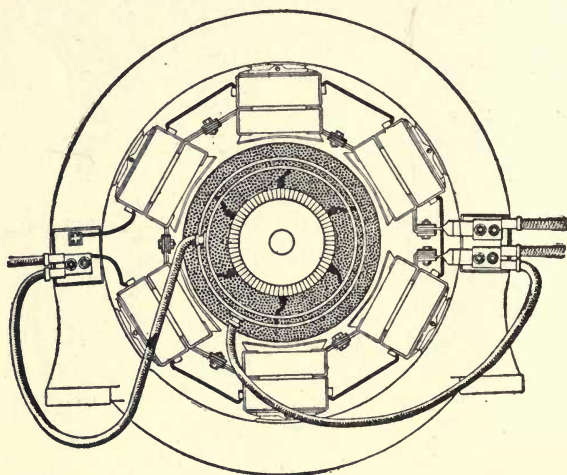

FIG. 220.—Same as Fig. 219, with brushes shifted 60 degrees.

The best solution of the problem is obtained by shifting the brushes from one neutral position to the next, which means that the brushes will be shifted 90 deg. on a four-pole machine, 60 deg. on a six-pole machine, etc. A comparison of Figs. 219 and 220 will make clear this idea. The brushes in Fig. 220 have been shifted clockwise around the commutator 60 deg. from that in Fig. 219. This will reverse the current through the field windings of Fig. 220 and is the equivalent of crossing the leads of both field windings in Fig. 219 and it also simplifies the problem.

CHAPTER XIV

DIRECT-CURRENT GENERATOR CHARACTERISTICS

Voltage Curves of Shunt Generator.—Electric generators and motors act in certain ways under given conditions; for example, as the current is increased in the field coil of a shunt

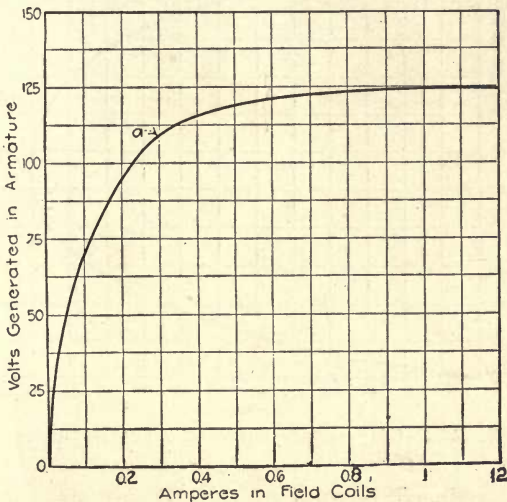

FIG. 221.—Direct-current generator voltage curve.

generator, the voltage will increase in value until the iron in the polepieces becomes saturated. Beyond the saturation point the voltage remains practically constant irrespective of the value of the current in the field coils. By plotting the volts at the armature terminals against the amperes in the field coils, as explained in Chapter XIII the result will be a curve similar to that shown in Fig. 221.

Similarly, the effect of the load on the voltage of a generator may be shown in a curve. This is done by connecting a voltmeter across the armature terminals and an ammeter in series in the circuit, as shown in Fig. 223; and after adjusting the voltage to normal, say 110 volts, put a load on the machine of, assume, 30 amperes, as indicated in Fig. 224. This, as shown in Chapter XIII, will cause the voltage to drop at the armature terminals: First, owing to the resistance of the armature, and second, the current in the field coils will also

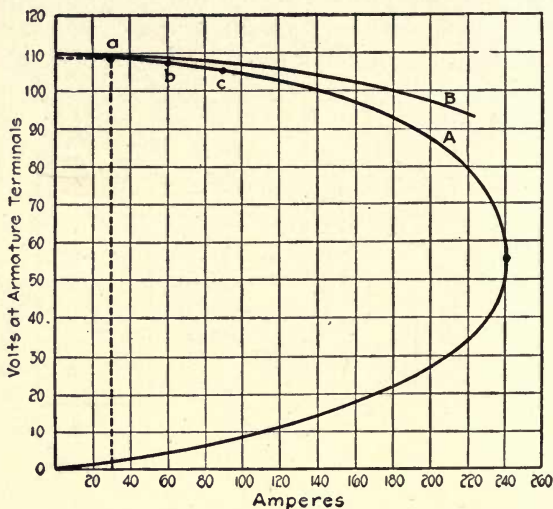

FIG. 222.—Load-voltage curve of shunt generator.

be slightly reduced because of the decrease in volts at the armature terminals. Assume that the volts at the armature terminals decrease 1.5, this will leave $E_a = 108.5$ volts available at the load and will give point *a* on curve *A*, Fig. 222, which is obtained by taking the 30-ampere division at the base of the curve and running up vertically until it intersects the horizontal line running out from the 108.5-volt division, as indicated by the dotted lines.

If the load is now increased to 60 amperes, the volts at the armature terminals will further decrease, say to 107; then

plotting the load current of 60 amperes against the voltage at the armature terminals, 107 volts, gives point *b* on the curve. Increasing the load to 90 amperes will cause the voltage to drop accordingly, or, as shown at point *c* on the curve, to be 105.5. Now, if the load is further increased, a corresponding decrease in voltage is obtained. However, it is evident that this process cannot keep on indefinitely, because if it did, eventually a point would be reached where an infinitely large current would be obtained on an infinitely small voltage.

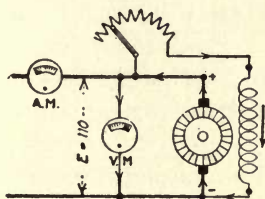

FIG. 223

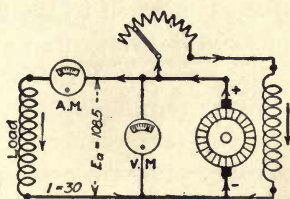

FIG. 224

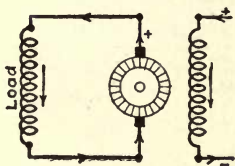

FIG. 225

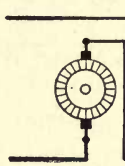

FIG. 226

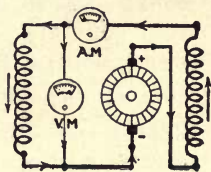

FIG. 227

FIGS. 223 to 227.—Diagrams of shunt-connected and series-connected generators.

What actually happens in a shunt generator is that the voltage decreases as the current is increased up to a certain value and then both volts and current decrease to zero or approximately so. This is shown on the curve; when the current has increased to 241 amperes, the volts have dropped to about 55. At this point, if the resistance of the circuit is further decreased to increase the current, the voltage and current begin to decrease and come back to zero, or theoretically so. However, on account of the residual magnetism in the polepieces maintaining a small voltage at the armature terminals, the volts and current will only approximate zero.

What has just been stated regarding the shunt machine indicates that if it was short-circuited, the voltage and current would drop to zero and no harm would be done. This is true of the self-excited shunt generator, but not of the other types, as will be seen in the following:

Volts Drop in Armature With Fields Separately Excited.

—If the field coils of the shunt machine are energized from an outside source, as in Fig. 225, then the field current will be maintained constant irrespective of the load. Consequently, the voltage generated in the armature will remain practically constant, and the volts drop at the armature terminals will be due to the armature resistance only. Therefore, the volts at the armature terminals will not decrease so rapidly as when the field coils are connected in parallel with the armature. The resultant curve for a separate-excited shunt generator will be similar to the curve *B*, Fig. 222.

Voltage Curve of Series Generator.—In the series-connected generator, Fig. 226, the machine cannot produce any voltage when it is disconnected from the load except that generated due to the residual magnetism in the polepieces. Consequently, at no load the voltage of a series machine is approximately zero, as against the shunt machine in which the voltage is at a maximum value at no load. By connecting a voltmeter and an ammeter to the series machine, as in Fig. 227, and taking readings for different loads, a curve will be obtained as in Fig. 228. It will be seen that the shape of the curve from zero to point *a* approximates the shape of the saturation curve, Fig. 221, from zero to point *a*.

The series generator as its voltage builds up with the load has not only to produce pressure to cause the current to flow through the external circuit, but also through the armature and field windings. The volts drop in the armature and field windings varies as the product of the current in amperes and the resistance of the windings in ohms. However, the total voltage generated in the armature winding does not increase as the current in the field winding. Referring to Fig. 221, it will be seen that up to point *a* on the curve, the increase in

volts is quite rapid as the field current is increased, but beyond this point the increase is very slow, being practically zero at the upper end of the curve. It is this latter fact that makes the voltage of the series generator decrease above a certain load.

In Fig. 228 the first 20-ampere load energizes the field coils to the extent that 50 volts is generated at the armature terminal. When the load is increased to 40 amperes, the volts

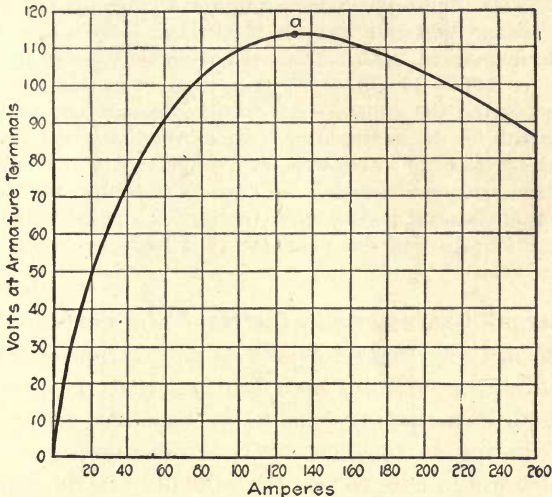

FIG. 228.—Load-voltage curve of series generator.

only increase to about 73 and at 60 amperes about 91 volts, until at 130 amperes, the maximum, or 114 volts, is developed at the armature terminals. From this it is seen that the volts at the armature terminals increase rapidly at first, but that the increase becomes less for a given number of amperes increase until an increase in load does not cause the volts to become greater but less, as in this case, when the load is made higher than 130 amperes.

Now, if we assume the resistance of the armature and field windings to be 0.2 ohm, then with a 20-ampere load on the machine the volts drop will equal amperes \times ohms, or $20 \times 0.2 = 4$ volts; that is, the armature is

actually generating 54 volts when supplying 20 amperes to the external circuit, but 4 volts is used up to cause the current to flow through the armature and field windings; therefore, only 50 volts is available at the armature terminals. At a 60-ampere load the volts drop in the armature is $60 \times 0.2 = 12$ volts. Hence, the armature is generating a total voltage at this load of $91 + 12 = 103$ volts. When the load has increased to 130 amperes, the volts drop in the armature is $130 \times 0.2 = 26$ volts, and there is generated $114 + 26 = 140$ volts. However, 26 volts is used up in the machine's windings, consequently only 114 is available at the armature terminals. Assume that the load is increased from 130 to 180 amperes. Then, the drop in the armature will be $180 \times 0.2 = 36$ volts. Further, assume that this increase in the load only causes the total voltage to increase to 143.5. Then, the available volts at the armature terminals is $143.5 - 36 = 107.5$. Hence, it is seen that the increased volts generated in the armature due to the increased load is not enough to compensate for the increased drop in the windings, and the available volts decrease with an increase in load. Hence, it is evident that the volts at the armature terminals on a series generator will increase in value with an increase in load until the iron in the magnetic circuit is near saturation; beyond this point the volts begin to decrease with an increase of load.

External Characteristic Curves.—The curves, Figs. 222 and 228, are sometimes referred to as external characteristic curves of the generator, from the fact that they are plotted from conditions existing outside the machine. If the voltage values existing in the armature windings were used in the curves, we would have to add the volts drop in the armature at the different loads to the voltage at the brushes corresponding to these loads, which would have given a higher pressure than that indicated on the curves in the figures. A load-voltage curve plotted by using the total voltage generated in the armature instead of that at the brushes is called an internal-characteristic curve.

Voltage Curve of Compound Generator.—With a series winding on the polepieces along with a shunt winding, as in the compound generators, Fig. 229, the load-voltage curve will, to a certain extent, be a combination of the shunt characteristic curve, Fig. 222, and the series curve, Fig. 228. In the compound-connected machine, Fig. 229, current is flowing through the shunt-field winding only, and this is adjusted by

the field rheostat to give normal voltage at the armature terminals. When a load is connected to the machine, as in Fig. 230, the current passing through the armature will tend to cause the voltage at the brushes to decrease, but the load current flowing through the series winding will increase the strength of the magnetic field and cause a greater voltage to be produced to compensate for the drop in the armature and

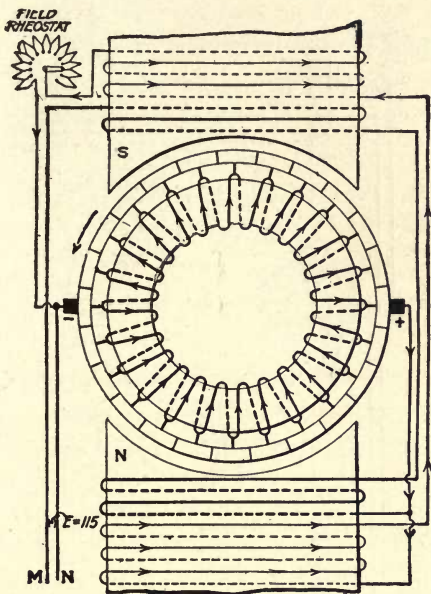

FIG. 229.—Diagram of compound-wound generator.

series-field winding. If we assume that the machine is normally generating 110 volts at no load, the density of the magnetic circuit would correspond to point *A* on the magnetization curve, Fig. 231. When the machine is carrying full load, if the current flowing in the series-field winding increases, the magnetic density to correspond to point *B* on the curve, then the armature will be generating about 124 volts; that is, the voltage generated in the armature has increased from 110 to 124, or 14 volts. Now, if the volts drop in the

armature, from no load to full-load, is only 14, then the volts at the armature terminals at full load will be the same as at no load.

Series Winding to Compensate for Volts Drop in Armature.—At first thought it may seem an easy matter to proportion the series-field winding so that it will just compensate for the drop in the armature circuit. A further consideration

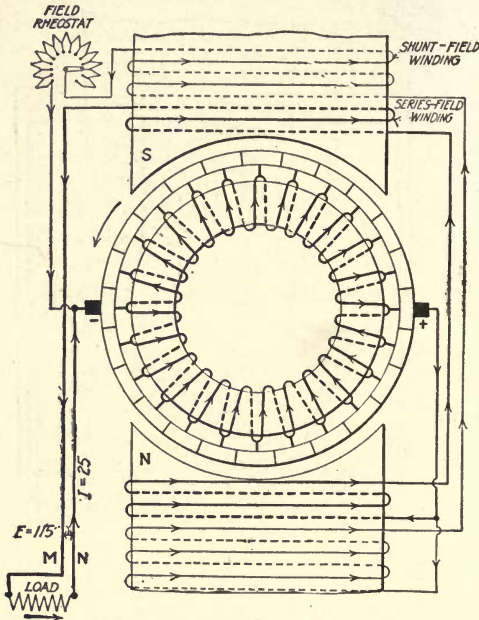

FIG. 230.—Diagram of compound-wound generator connected to load.

of the curve, Fig. 231, will show that this is impossible. If point *A* indicates the no-load voltage and point *B* the volts generated in the armature at full load, point *C*, half-way between *A* and *B*, will indicate the volts at half load. But from *A* to *C* the voltage has increased from 110 to 120, whereas from *B* to *C* it has only increased from 120 to 124, or 4 volts, against 10 on the first half of the load. The volts drop in the armature is proportional to the amperes, consequently if full-load current causes a drop of 14 volts, then half full-load cur-

rent will cause 7 volts drop. But with half full-load current flowing in the series-field winding, in this case, it caused 10 volts increase, therefore, the voltage at the brushes is 3 volts higher than at no load. What has really happened to the voltage of the compound generator from no load to full load is indicated in curve *B*, Fig. 232, assuming 200 amperes full load. Here it is shown that although the voltage is the same at full load as at no load, nevertheless, it has not been constant between these points, increasing in value during the first half

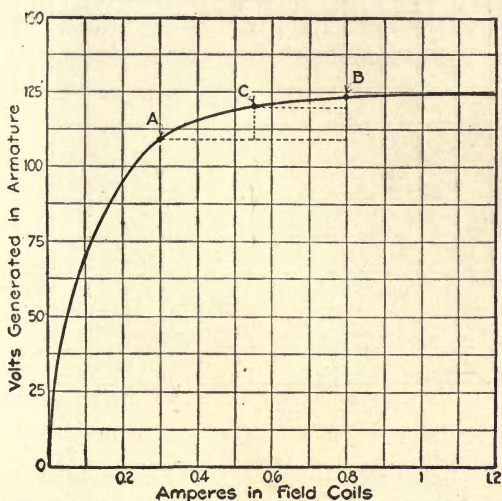

FIG. 231.—Direct-current generator voltage curve.

of the load and then decreasing to normal again during the last half. Furthermore, it is not possible to design a compound generator that has a constant voltage from no load to full load. However, conditions similar to that indicated by curve *B*, Fig. 232, can be approximated.

Voltage at Terminals of Compound Generator.—A compound generator that develops the same voltage at full load as at no load is said to be flat-compounded. It is possible, by proportioning the shunt- and series-field winding, to design a compound machine where the voltage will increase from no load to full load, as indicated by curve *A*, Fig. 232.

For example we assume that the full-load current causes 14 volts drop in the armature. Now, if the current flowing through the series-field winding caused a 20-volt increase in the armature, then the voltage at the armature terminals will be $20 - 14 = 6$ volts higher at full load than at no load. When the voltage of a compound generator increases from no load to full load, the machine is said to be over-compounded.

On the other hand, suppose that when full-load current is flowing in the series-field winding it caused only 8 volts increase; then, since

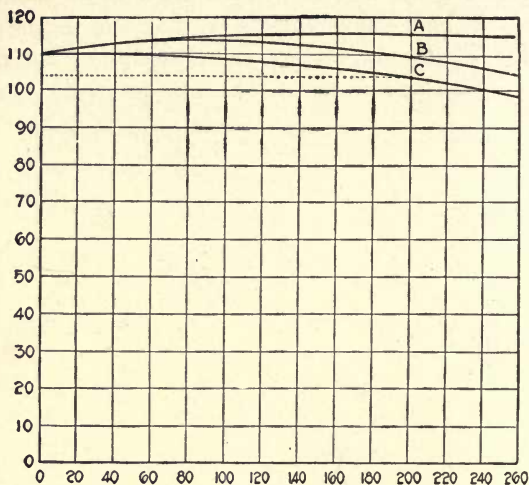

FIG. 232.—Compound-wound generator load-voltage curves.

there is 14 volts drop in the windings at full load and only 8 of these volts are compensated for, the pressure will decrease at the brushes, $14 - 8 = 6$ volts. Such a condition is represented by curve C, Fig. 232. A compound generator the voltage of which decreases from no load to full load is known as being under-compounded.

Proper Amount of Compounding.—Another feature in obtaining the proper amount of compounding of the generator is the proper number of turns in the series winding. This winding in the large-sized machine is made of a heavy copper bar, as in Fig. 233, therefore, the terminals will have to come out on opposite sides, so that the connection can be made conveniently between the coils. This means that the minimum number of turns in the coil must be 1.5. Then, to maintain the proper position of the coil's terminals the number of turns will have to be 1.5, 2.5, 3.5, etc. One-half turn in the series-field

winding at first thought may not seem to be of any serious importance. However, when it is considered that in a 200-kw. 110-volt machine the normal full-load current is approximately 2,000 amperes, and this current flowing through one-half turn gives 1,000 ampere-turns, the effect that only a small fraction of a turn in the series winding will have upon the voltage of such a machine at once becomes apparent.

Here again, in the design of the series winding, it is impossible, except by a coincidence, that the correct number of turns can be obtained. The result is that as the series-field winding is designed on most compound generators, the machine is over-compounded.

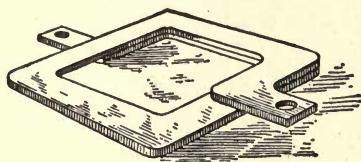

FIG. 233

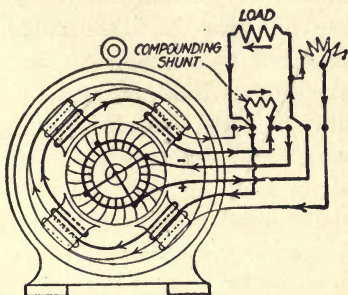

FIG. 234

FIG. 233.—Large-capacity series-field coil for compound generator.
 FIG. 234.—Compound generator showing location of compounding shunt.

For example, assume that in working out the design of a machine it is found to give the proper amount of compounding, that 3.8 turns will be required in the series winding. In this the designer has the choice of using only 3.5 turns and having the machine slightly under-compounded, or using 4.5 turns and over-compounding the machine. The latter is the best course for several reasons. Due to imperfections in the materials and workmanship, the machine may vary somewhat from what was expected of it. In fact, it is practically impossible to build two machines after the same design and from the same lot of stock and have them both possess identically the same characteristics. Therefore, it is good policy to use a liberal design in the series-field winding, since there is a simple

means for adjusting the ampere-turns of this winding when the machine is over-compounded. This consists of connecting what is known as a compounding shunt directly across the series-winding terminals, as shown in Fig. 234.

Compounding Shunt.—After the machine is built and in operation in the shop, a test is made to find out the amount of resistance that must be connected across the series-field terminals to give the required compounding, and then a shunt is made for this purpose and connected to the terminals of the series winding. Then, instead of all the load current passing through the series winding, only part of it does, depending upon the resistance of the shunt. If the full-load current of the machine is 1,000 amperes and only 800 amperes are required to compensate for the volts drop in the series and armature windings, at full load, then the shunt is made to have a resistance four times as great as that of the series winding, so that when it is connected in parallel with the series winding one part of the current will pass through the shunt and four parts through the series winding, or any degree of over-compounding may be obtained up to the maximum by increasing the resistance of the shunt. Direct-current generators have been built for railway work in which the voltage increased from 500 at no load to 550 at full load, this increase in voltage being used to compensate for the volts drop in the feeders.

Short-Shunt and Long-Shunt Connection.—In passing, attention may be called to the way that the shunt-field windings are connected. In Figs. 229 and 230 the shunt winding is connected directly to the armature terminals. This is known as a short-shunt connection. In Fig. 234 the shunt winding is connected directly across the series winding and armature in series, so that in this case the shunt-field current passes through the series winding also. This is known as a long-shunt connection. Since the shunt-field current is only a very small percentage of the total load of the machine, it is evident that it makes little difference which connection is used, the choice being more a matter of convenience than anything else.

CHAPTER XV

LOSSES IN DIRECT-CURRENT MACHINERY

Loss in Transformation of Energy.—Whenever energy is changed from one form to another, there is always a loss in the transformation. For example, the amount of energy transmitted by the steam to the cylinder of an engine in the form of heat is not all available at the flywheel to do useful work. A large percentage of the energy actually supplied to the engine is lost in the exhaust, in radiation from the surface of the cylinder and in overcoming the friction of the moving parts, etc.

What has taken place in the engine is, the energy in the steam has been converted into a mechanical form of energy which may be used to do the mechanical work of driving any kind of machinery. If the engine is used to drive an electric generator, then we will have another transformation of energy; that is, the mechanical energy transmitted to the engine's shaft or flywheel will be converted into electrical energy and transmitted through the circuits to the devices supplied by the generator. In this transformation from a mechanical to electrical energy there is also a loss just as in the steam engine; that is, if the energy delivered to the engine's flywheel is capable of developing 100 hp., then less than 100 hp. will be delivered to the circuits. Part of the power developed at the engine shaft will be expended in overcoming the friction of the moving parts of the generator, exciting the field coils, the losses due to the resistance of the armature circuits and eddy-current and hysteresis losses.

Friction Losses.—The friction losses in a direct-current machine consist of the friction of the bearings, brushes on the

commutator and the friction of the air upon the revolving element. The last item is usually known as the windage losses. The total friction losses amount to about 6 per cent of the capacity of the machine for a 1-kw. unit to about 3 per cent for a 1,000-kw. unit. These may be considered as the mechanical losses of the machine; that is, they represent mechanical power that has been supplied to the generator and that has not been converted into electrical power, but has been expended in doing the mechanical work of overcoming the friction of the generator.

Current to Excite the Field Coils.—The current that is used to excite the field coils represents electrical power that has been generated in the armature, but is used up within the machine to energize the field coils, therefore is not available for doing work outside of the machine. The amount of power required to energize the field coils of direct-current machines is about 6 per cent of the total output for machines of 1-kw. capacity to about 1.4 per cent in 1,000-kw. sizes.

Since the energy expended in the field rheostat is also charged up against field losses, the power loss in the shunt-field winding is practically constant, being only changed slightly by the hand adjustment of the rheostat. The losses in the shunt-field winding are therefore equal to the volts at the armature terminal times the current supplied to the field coils.

The energy expended in the field coils is sometimes referred to as the excitation losses or I^2R losses in the shunt-field winding; that is, the loss in the field coils is equal to the square of the current times the resistance of the field coils and that of the section of rheostat in series with the coils.

For example, the total resistance of a shunt-field circuit is $R=27.5$ ohms, and the voltage at the armature terminal is $E=110$; then the current flowing in the field coils is $I = \frac{E}{R} = \frac{110}{27.5} = 4$ amperes, and the watts $W = EI = 110 \times 4 = 440$. The watts are also $W = I^2R = 4^2 \times 27.5 = 4 \times 4 \times 27.5 = 440$, which gives the same result as the former method.

Copper Loss in the Armature.—In the previous chapters we found out that a part of the voltage generated in the

armature was used up in overcoming the resistance of the armature windings to the flow of the current. This also represents a loss of power supplied by the prime mover to the generator. This loss is usually called the armature copper loss, or I^2R loss, and is one of the chief factors in increasing the temperature of the machine. The power loss in the armature copper is equal to the voltage drop through the armature winding times the current supplied by the armature; it is also equal to the square of the current times the resistance of the armature winding.

For example, the resistance on a given armature is $R=0.1$ ohm, and the total current supplied to the load and shunt-field winding is $I=150$ amperes; then the volts drop in the armature is $E_d=IR=150\times 0.1=15$ volts, and the watts loss in the armature is $W=E_dI=15\times 150=2,250$ watts. The watts loss is also $W=I^2R=150\times 150\times 0.1=2,250$.

The losses in the armature copper vary from about 4 per cent of the capacity of the machine in 1-kw. units to 1.8 per cent for units of 1,000-kw. capacity. These losses vary as the square of the current supplied by the armature and are practically zero at no load, being only those due to the shunt-field winding current, and at a maximum value at maximum load. The resistance of the armature circuit is usually considered as that of the armature windings, brushes, series-field windings if the machine is compound-wound, and the machine leads and terminals.

Eddy-Current Losses.—In Chapter XI it was shown that when the armature core is revolved between the polepieces, it cuts the lines of force and therefore generates a voltage the same as the windings do. It was also shown that the current caused to circulate around in the core by this voltage, or eddy current as it is called, created a pull that opposed the turning effort of the prime mover driving the generator, consequently represented a direct loss of power. The eddy-current losses are usually combined with the hysteresis losses and are called the iron or core losses.

Hysteresis Losses.—The hysteresis losses are those which are due to the friction of the molecules, of the iron in the

armature core, on each other as they align themselves with the lines of force when the armature is revolved. This is illustrated in Figs. 235 to 237. In Chapter II it was explained that a piece of iron acted as if each molecule was a magnet

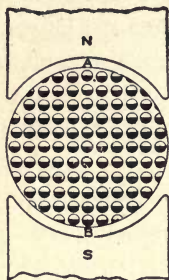

FIG. 235

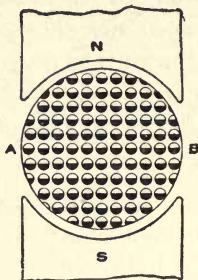

FIG. 236

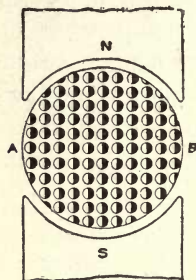

FIG. 237

FIGS. 235 to 237.—Shows how iron molecules in armature core are supposed to arrange themselves when field poles are magnetized.

having a north and a south pole, and that under normal conditions the molecules arrange themselves so that the N and S poles of one molecule were neutralized by the N and S poles of other molecules and thus form a neutral condition, as in Fig. 238. When the piece of iron is brought under the pole of a



FIG. 238



FIG. 239

FIG. 238.—Supposed arrangement of the molecules when a piece of iron is not magnetized.

FIG. 239.—Supposed arrangement of molecules when iron is magnetized.

magnet, this pole will attract the opposite pole of the molecules of the iron and cause them to be arranged in a systematic group, as in Fig. 239, thus producing an N pole at one end of the bar and an S pole at the other. In the same way, when the field poles of an electrical machine are magnetized, they cause the molecules in the armature core to arrange themselves systematically as in Fig. 235. Now if the armature core is turned 90 deg. from the position in Fig. 235, as in Fig. 236, it

will be seen that although the core as a whole has revolved 90 deg. to the left as indicated by *AB*, the field magnets have held the molecules of the iron core in the same position in each case. For this to be possible the molecules have done what is equivalent to turning to the right 90 deg. If they had remained in a fixed position in the core, the condition that would exist is that in Fig. 237, from which it is seen that if each molecule turns 90 deg. to the right from the position in the figure, a condition exists in the core corresponding to that in Fig. 236. This is just what appears to be going on in the armature core all the time that it is revolving and the field poles are magnetized. As the armature revolves as a whole in one direction the molecules are revolving about their axis in the opposite direction. The molecules revolve at the same rate as the armature core in a two-pole machine, or one revolution for one pair of poles. The latter statement conforms to the condition existing in all multipolar machines; that is, the molecules make a complete revolution about their axis for each pair of poles in the machine. In a four-pole machine they would be revolving twice as fast as the armature, in a six-pole machine three times as fast, etc.

To cause the molecules to revolve about their axis requires a certain amount of power. The power that is expended in changing the position of the molecules is the hysteresis losses in the core. This, combined with the eddy-current losses, is called the core losses, and amounts to about 4 per cent in machines of 1-kw. capacity to about 1.2 per cent in 1,000-kw. machines. If an attempt is made to turn the armature of an electrical machine by hand, with the field poles dead, it should turn very easily, but when the field poles are magnetized, it will be found that a greater effort must be developed to turn the armature. This increased effort required under the latter condition is due almost entirely to hysteresis, or in other words, to rotating the molecules of the core, and when the machine is in operation represents a loss of power.

Total Losses in an Electric Machine.—The total losses at full load in a 1-kw. machine amount to about 20 per cent of

the output, while in the 1,000-kw. machine they are about 4.5 to 5 per cent. In other words, when a 1-kw. machine is delivering its full-rated load (1-kw.) it will require about 1.2 kw. to drive it, and when a 1,000-kw. machine is delivering its full-rated load (1,000 kw.) it will require about 1,050 kw. to drive it.

The ratio of the output of a given machine to the input is called the efficiency and is usually expressed in a percentage, thus: *Per cent efficiency* = $\frac{\text{output} \times 100}{\text{input}}$, from which, *output* = $\frac{\text{input} \times \text{per cent efficiency}}{100}$, and *input* = $\frac{\text{output} \times 100}{\text{per cent efficiency}}$.

For example, a given generator requires 50 hp. to drive it when supplying 32 kw. to a lighting system. Find the percentage of efficiency that the machine is operating at.

The input in this case is horsepower,

$$\text{Kilowatts} = \frac{\text{hp.} \times 746}{1,000} = \frac{50 \times 746}{1,000} = 37.3;$$

then

$$\text{Per cent efficiency} = \frac{\text{output} \times 100}{\text{input}} = \frac{32 \times 100}{37.3} = 86 \text{ per cent approximately.}$$

That is, only 86 per cent of the power supplied to the machine is available for doing useful work in the lighting system.

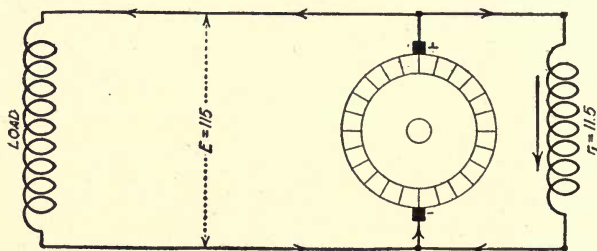

FIG. 240.—Diagram of shunt-generator connected to load.

A given shunt generator, Fig. 240, when supplying a constant load, requires 175 hp. to drive it. The voltage at the armature terminals under this condition is 115. The core losses of this machine amount to 4.5 hp. The field-circuit resistance is 11.5 ohms, the armature-copper losses amount to 3,500 watts, and to overcome the friction of the machine

requires 1.5 hp. Find the percentage of efficiency at which the machine is operating.

The input in this case is 175 hp., and the output will be equal to the input minus the losses in the machine. The field current i_1 is equal to the volts divided by the field-circuit resistance r_1 , or $i_1 = \frac{E}{r_1} = \frac{115}{11.5} = 10$ amperes. The field watts $W_1 = E i_1 = 115 \times 10 = 1,150$. The core losses are 4.5 hp., or $4.5 \times 746 = 3,357$ watts; 1.5 hp., or $1.5 \times 746 = 1,119$ watts is expended in overcoming the friction of the machine, and the armature losses are 3,500 watts. Then the total watts loss is $1,150 + 3,357 + 1,119 + 3,500 = 9,126$ watts. The horsepower input is 175, or $175 \times 746 = 130,550$ watts.

Output equals the difference between input and the losses in the machine, or in this case $130,550 - 9,126 = 121,424$ watts.

$$\text{Per cent efficiency} = \frac{\text{output} \times 100}{\text{input}} = \frac{121,424}{130,550} = 93 \text{ per cent.}$$

Find at what value a circuit-breaker should be set, or what size fuses should be used, to protect a 75-kw. 120-volt generator if the load is to be limited to 120 per cent of normal.

The normal load in watts would be the normal load in kilowatts multiplied by 1,000 (since there are 1,000 watts in a kilowatt) or $75 \times 1,000 = 75,000$ watts.

The normal current would be the normal load in watts divided by the voltage of the generator, or $\frac{75,000}{120} = 625$ amperes. If the load is to be limited to 120 per cent of the normal value, the current would be 1.2 times the normal current, or $1.2 \times 625 = 750$ amperes. The circuit-breaker would therefore have to be set for 750 amperes, or fuses of that capacity be used.

A generator supplies 750 amperes at 130 volts while operating at 89 per cent efficiency. How many horsepower would be required to drive it?

The load supplied by the generator, expressed in watts, would be the current which it delivers multiplied by the voltage, or $750 \times 130 = 97,500$ watts. If it operates at 89 per cent efficiency, 97,500 watts must be 89 per cent of the power required to drive it. If W represents the power required to drive the generator, we have $0.89W = 97,500$ watts, from which $W = \frac{97,500}{0.89} = 109,550$ watts. Since there are 746 watts to one horsepower, the power required to drive the generator is the power in watts divided by 746, or $\frac{109,550}{746} = 147$ hp. (nearly).

CHAPTER XVI

DIRECT-CURRENT MOTORS

Fundamental Principle of Electric Motor.—Figs. 139 to 145, Chapter X, explains the fundamental principles of the electric motor, therefore should be carefully studied before taking up this chapter. It has been shown that when a current flows through a conductor in a magnetic field it will tend to cause the conductor to move at right angles to the lines of force. The direction that the conductor will tend to move in will depend upon the direction of the lines of force and the direction of the current in the conductor. This relation is explained by the rule Figs. 143 and 144, Chapter X.

Consider an armature such as is used in a shunt generator, Fig. 241, to have current passed through it after the field coils have been connected to the mains; then there will be a number of current-carrying conductors situated in a magnetic field, all of which will tend to be moved across the path of the field. If the forces impelling them are all in the same direction, they will cause the armature core on which they are mounted to revolve. The direction of the force on any conductor can, as previously described, be determined by the finger rule, as illustrated in Figs. 143 and 144. The relative direction of the magnetic field and current will depend on the position of the brushes on the commutator. It will be found that, theoretically, the brushes should be on the neutral axis for proper operation, exactly as was found in the case of the generator.

In Fig. 241 the direction of the current in each conductor above the neutral axis is away from the observer, and in each of those below this axis the current is toward the observer.

The direction of the field in each case is upward, consequently every conductor above the neutral axis will tend to move to the right and every one below this axis will tend to move to the left, the result being that the armature will be made to revolve in a clockwise direction.

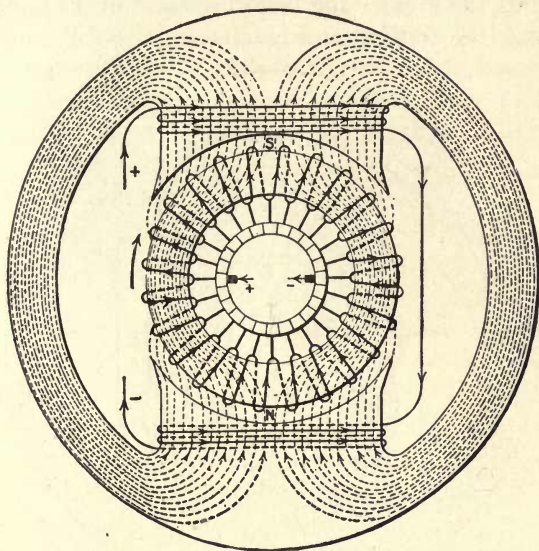

FIG. 241.—Diagram of direct-current motor.

Effects of Changing Brush Position.—Should the brushes be moved to the position shown in Fig. 242, the armature will refuse to rotate, for then the direction of the current in the armature conductors between *a* and *b* and those between *a* and *d* will be toward the observer. One set of these conductors will therefore tend to revolve the armature in a counterclockwise direction and the other in a clockwise direction. Likewise the current in conductors between *c* and *b* and in those between *c* and *d* is down through the plane of the paper. Hence we have conductors between *a* and *b* and between *c* and *d* producing counterclockwise rotation and those between *b* and *c* and between *d* and *a* opposing them with an equal force in the opposite direction; consequently there can be no motion.

For intermediate positions of the brushes, the total number of conductors tending to move in one direction will be greater than the total number tending to move in the other direction under the same pole, hence there will be rotation in the direction of the greater force. The nearer the brushes are to the neutral axis the greater the force becomes until exactly at the neutral axis the force is at a maximum.

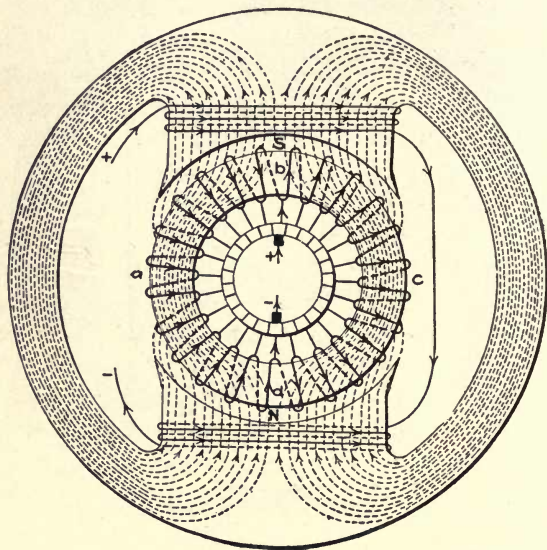

FIG. 242.—Same as Fig. 241; except brushes are shifted 90 degrees.

From the foregoing it is evident that a shunt generator can be used as a motor. The same holds true for all the other types of generators, and as a matter of fact, whether a dynamo-electric machine is called a generator or a motor depends largely on the name-plate. We might take a generator, remove its name-plate and replace it with one specifying a slightly different rating, and would have a motor of the same type. If the generator were a compound one, the motor would be a compound motor, etc.

Another Theory of Motor Operation.—Before going further it will be of interest to discuss a theory of motor operation

which is different from the one already given, but which explains quite as well as the foregoing how the motor operates. In Fig. 243, the current flowing through the upper half of the armature is in a direction to produce an N pole on the left-hand side, and an S pole on the right-hand side. The same is true of the current in the lower half. Therefore we have an N in the upper half opposed by an N pole in the lower half, likewise, for the S poles, consequently resultant N and S poles are produced on the armature as shown in Fig. 243. With

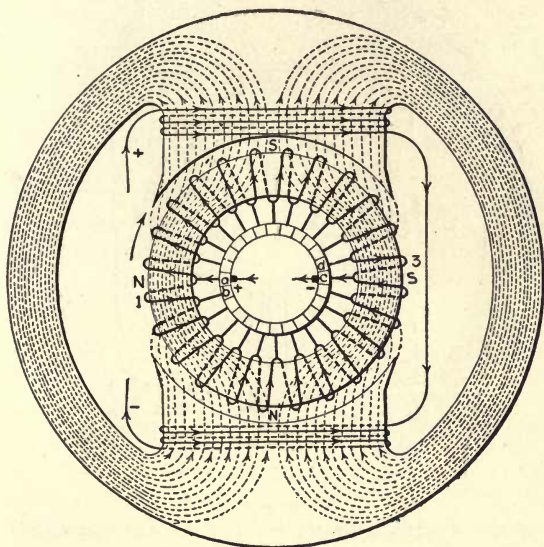

FIG. 243.—Same as 241, except armature poles are indicated.

the field poles magnetized, the N pole of the armature will be attracted to the S pole of the field frame and the S pole of the armature to the N main pole, therefore it will begin to turn in a clockwise direction. So long as the brushes rest on commutator bars *a* and *c*, the direction of the current through the windings remains unchanged, hence the N and S poles remain fixed in the ring and turn with it.

Fig. 244 shows their position when the commutator bars *a* and *c* have left the brushes and bars *b* and *d* have made contact

with them. At the instant when this change occurs, the current in coils 1 and 3 is reversed and the N and S poles of the armature are instantaneously transferred backward through a space equal to that occupied by one armature coil so that they are again opposite the brushes as in Fig. 243.

In this we have the main poles tending to pull opposite poles of the armature up to them, but as fast as the armature moves up one coil the current is reversed in the coil by the

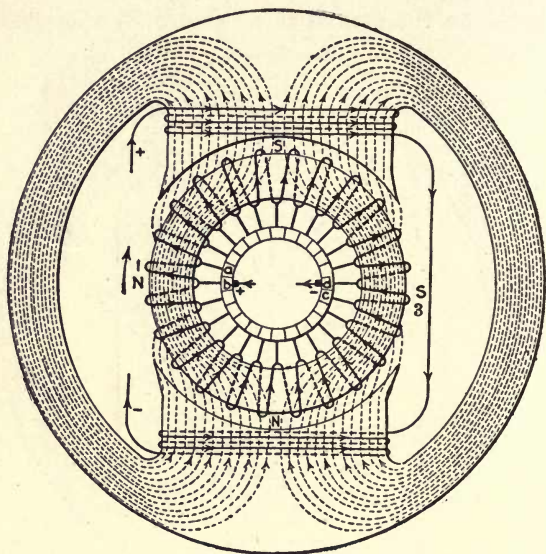

FIG. 244.—Same as 243, with armature moved one commutator segment.

commutator action, and as a result armature poles are maintained in a position at the brushes, as the armature rotates.

Although ring armatures have been used in the foregoing description for the sake of clearness, the theories advanced apply equally to drum-type armatures, since N and S poles are formed in them precisely as in ring armatures. The first theory presented, that based on the motion of a conductor in a magnetic field due to the current being passed through it, is the more fundamental of the two, but the second one, that based on the attraction of magnetic poles, is extremely con-

venient and is a considerable aid in coming to a thorough understanding of the principles involved.

Both Motor and Generator Action Present in all Dynamo-Electric Machines.—Having given an armature situated in a magnetic field as in a dynamo-electric machine, the machine becomes a generator when the armature is caused to revolve by applying mechanical power to it, whereas when electrical power is supplied to it, the machine becomes a motor and

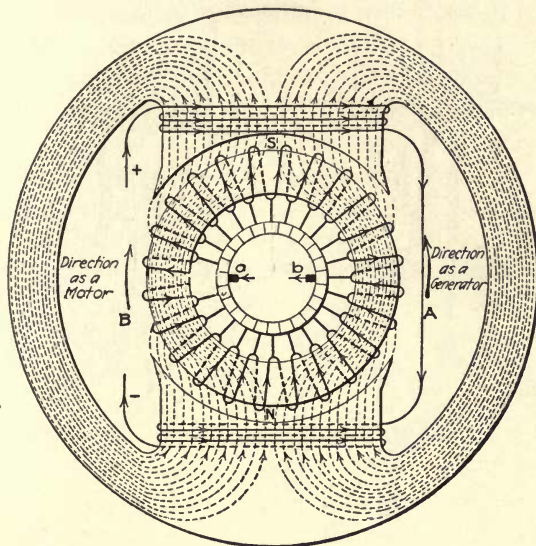

FIG. 245.—Indicates both motor and generator action in same direct-current machine.

delivers mechanical power. In both the cases a number of conductors are carrying currents and they are moving across a magnetic field. The question then arises, what is the difference which causes the machine to act as a generator in one case and as a motor in the other if the conditions in both cases are the same? Briefly stated, it is that the two actions are opposite to each other and that in one case the generator action is greater than the motor action, and in the other the motor action exceeds the generator action. That is, both actions are present

whether the machine be operating as a generator or as a motor, but the one is greater than the other, depending on whether it is being used to convert mechanical into electrical energy or vice versa.

Consider how these actions combine to give the results obtained. Suppose we have an armature situated in a magnetic field, as in Fig. 245, and that the direction of the current in the armature winding and the direction of the flux is as

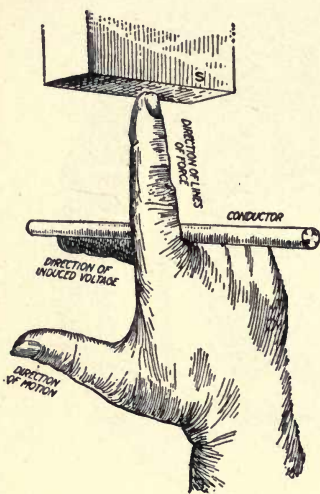

FIG. 246

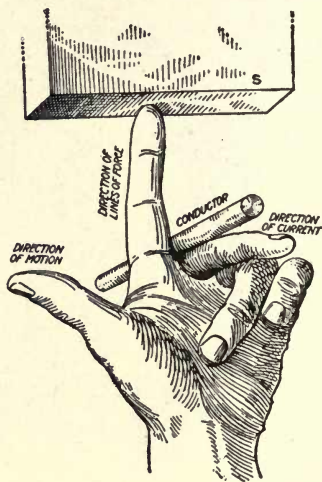

FIG. 247

FIG. 246.—Right-hand rule for generator.

FIG. 247.—Left-hand rule for motor.

indicated. Unless the direction in which the armature was revolving is known, it would be impossible to say whether it was being driven as a generator or was running as a motor. It might be operating as either. As a generator it would have to be driven in the direction of the arrow *A* if the current is to be in the direction shown, as may be determined from the right-hand rule illustrated in Fig. 246. As a motor it would revolve in the opposite direction if the direction of the current was made the same, as shown in the left-hand rule illustrated in

Fig. 247. It is therefore apparent that, as previously stated, the motor and generator actions are always opposed.

Counter-Electromotive Force.—Suppose the machine to be operating as a generator. When it has a load connected to it, the current passing through the armature tends to make all the conductors of the winding move across the field in the direction *B*, and in order that this force shall not reduce the speed at which the engine or other prime mover is shoving them in the direction *A*, the prime mover must exert a pull equal to the drag of the conductors.

Consider, now, that the machine is operating as a motor. It will, of course, be revolving in the direction *B*. When the armature conductors move in this direction through the field an e.m.f. would be generated in opposition to the applied voltage, illustrating in another way how the motor and generator actions oppose each other. The e.m.f. which is generated by the conductors of the motor in opposition to the applied voltage is called the counter-electromotive force of the motor; it is abbreviated counter-e.m.f., or c.-e.m.f. and is also often referred to as back-e.m.f., the words counter and back indicating that it is in opposition.

Since the armature of the motor generates an em.f. in opposition to the voltage applied to it, the current which can flow through it is equal to the difference between the applied voltage and the counter-e.m.f. divided by the resistance of the armature. That is,

Applied voltage — *counter-e.m.f.* / *armature resistance* = *armature current*, that is,

$$I = \frac{E - e}{R},$$

where *I* equals the armature current, *E* the applied

volts, *e* the counter-electromotive force, and *R* armature resistance in ohms. The counter-e.m.f. of a motor will always be less than the applied voltage, for if the two were to become equal to each other no current could flow, and the armature would stop. The moment the armature began to slow down, a very interesting action would take place, as shown in the following:

How Motor Operates when Loaded.—In the study of gen-

erators it was found that the em.f. generated by conductors moving across a magnetic field is proportional to the rate at which the lines of force are cut by the conductors. If the speed is decreased while the field strength is kept constant, the e.m.f. will be decreased because the total number of lines of force passed in one second will be less than before. It follows that the instant the armature of the motor slows down, the em.f. which its conductors generate will be decreased. That is, its counter-e.m.f. would become less than the applied voltage, in consequence of which a current would flow, and as soon as the current became great enough to keep the armature revolving, there would be no further reduction in speed; the armature would continue to revolve at whatever speed it had dropped to. If the motor is running idle, only a small current will be required to keep it running, merely enough to overcome friction and other internal losses. The applied voltage multiplied by the current flowing at no load will give the watts used up in the motor to overcome its losses. Were a load now to be placed on the motor it would of course tend to retard its motion. The speed would again begin to drop and would continue to do so until the counter-e.m.f. had been reduced to such a value as would allow sufficient current to flow to overcome the load imposed on the motor. The product of the voltage and current would now be the watts required to drive the load plus the internal losses of the motor.

Provided the supply voltage remained constant we would find a certain definite speed for each load, and the greater the load the lower the speed. The amount of change in speed for change in load differs greatly in the different types of motors. The shunt motor suffers the least change, the series motor the most, the compound motor being in between the two. It is well to note here that the difference between the applied voltage and the counter-e.m.f. is never very great. An example will illustrate the reason for this.

If a 5-hp. 110-volt motor whose armature resistance is 0.1 ohm is carrying full load, it would require about $5 \times 880 = 4,400$ watts. Small-size motors require about 880 watts per horsepower output. The current

required equals watts divided by voltage, or $4,400 \div 110 = 44$ amperes. The voltage drop in the armature would be 44 amperes multiplied by 0.1 ohm, or 4.4 volts, which would be the difference between the applied voltage and the counter-e.m.f., and the value of the latter would therefore be 110 volts minus 4.4 volts, or 105.6 volts. In this case, the drop in voltage is only about 4 per cent for full load. Any material decrease in the counter-e.m.f. would allow an enormous current to flow and would result in the operation of the safety devices protecting the motor and the circuit to which it is connected. For instance, if the counter-e.m.f. should drop to 80 volts, the difference between it and the applied voltage would be 110 volts minus 80 volts, or 30 volts, and the current taken by the armature would be this difference divided by the armature resistance, or 30 volts divided by 0.1 ohm, equals 300 amperes, which is seven times the full-load current.

How Speed of Motor May Be Adjusted.—It has been said that the speed of a motor adjusts itself to the value at which the correct counter-e.m.f. for the particular load on it will be generated; that is, the counter-e.m.f. is the controlling factor in the automatic regulation of the motor. The counter-e.m.f., however, is affected by the strength of the magnetic field, which leads to another feature in the operation of the machine. Suppose a shunt motor, for example, to be revolving at a certain speed while driving a load. If the field strength were to be reduced, as it would be if we were to decrease the field current for any reason, then the counter-e.m.f. generated would drop in proportion. A drop in the counter-e.m.f., however, would cause the motor to take a greater current than required by the load, consequently the motor would speed up. It should be remembered, however, that the field flux is less than it was, but the percentage increase in armature current far exceeds the percentage decrease in flux, and the armature does speed up. Upon speeding up, the counter-e.m.f. again increases, thereby decreasing the armature current until the point is reached at which the current flowing is again just sufficient to take care of the load. Since the load is being driven at a greater speed, it will require more power to drive it, and consequently, the new value of armature current will be somewhat higher than that previously observed.

When the field current is increased, the consequences are

the converse of those described and the speed of the motor is reduced. As before, assume that while a shunt motor is running under a given set of conditions, the field current is increased, the counter-e.m.f. is thereby increased and the armature current decreased. The motor then takes an amount of current insufficient to drive the load at the original speed and is compelled to slow down. Upon doing so, the counter-e.m.f. decreases, allowing the armature current to increase. The speed will decrease until the armature current has attained a value sufficiently great to take care of the load. The new current will be somewhat less than that previously observed since the speed has been somewhat reduced.

The fact that the speed of a motor increases when the field current decreases and decreases when the field current increases, is an extremely important one, since on it depends the chief method of control of adjustable-speed motors.

CHAPTER XVII

TYPES OF DIRECT-CURRENT MOTORS

Five Types of Motors.—Direct-Current motors may be divided into five general classes according to their electrical characteristics; namely, series, shunt and compound, interpole and compensating types. In all these types the armatures may be the same, the essential difference being in the field-pole windings and the way the latter are connected to the armature. The simplest type is the plain series motor, which derives its name from the fact that the armature and field windings are connected in series. Since the armature and field

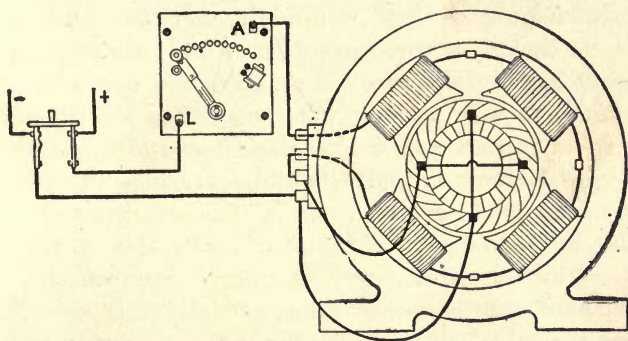

FIG. 248.—Connection diagram for series motor and starting box.

windings are connected in series, the latter passes all the armature current. Consequently, the wire in the field coils must be large enough to carry the total load current without excessive heating or voltage drop. For this reason the field coils of a series motor are usually wound with a comparatively small number of turns of relatively large-sized wire. The connections of a series motor to an ordinary type of manual starting box are shown in Fig. 248. It will be noticed that

there is but one circuit through the starting box, armature and field windings, the armature and field windings being connected in series. Where motors of this type are of 3.5 hp. in size and above, they can generally be determined by inspection, by noting if the machine has only main poles, as in the figure, and if the field and armature leads are the same size. A test can be made with a lamp and circuit having machine voltage. If the motor is of the series type, the lamp should light up to full brilliancy when connected across either the field or armature terminals excepting in the case of very small machines.

Torque of Series Motor Varies as the Square of the Current.—One of the serious disadvantages of a series motor is that it will race if its load is removed and will destroy itself unless disconnected from the line. If the load is changed on the motor, the speed will vary inversely—that is, if the load is increased the speed will decrease, and if the load is decreased the speed will increase—consequently, the motor is not adapted to constant-speed service. For this reason the motor is used to a very limited extent excepting in cases where it is continuously under the control of an operator; for example, on cranes and railway service. The motor has a characteristic that makes it well adapted to these two classes of service; namely, within certain limits its torque (turning effort) varies as the square of the current; that is, if the current taken from the line is increased by 2, the torque will be increased four times. Why this is so may be readily understood by a consideration of what happens in the motor when the value of the current is doubled in the motor's windings. For example, if the motor takes 10 amperes from the line, this current passes through both the armature and field windings and produces a certain number of lines of force per square inch in the field poles, which is reacted upon by the current passing through the armature conductors and causes the armature to develop a given turning effort. If the current was doubled in the armature, the lines of force remaining constant, the turning effort would be doubled. On the other hand, if the value of the current in the armature was maintained constant and the lines of

force doubled in the field pole, the torque would also be doubled. Since the field and armature windings are connected in series, if the current is increased to 20 amperes, then the current will be doubled not only in the armature's conductors, but also through the field coil. The latter will increase the lines of force from the field pole by 2. Consequently, when we have two times the current in the armature conductors acting upon two times the flux from the polepieces, this will give four times the turning effort developed by 10 amperes.

Of course this holds true only up to the point where the magnetic circuit begins to approach saturation. Then the increase in torque for an increase in current is not so marked. This characteristic of the torque increasing as the square of the current, makes the motor well adapted to work that requires frequent starting under heavy loads, as in railway and crane work, and it is in these two applications that the series motor finds its greatest application.

Shunt-type Motors.—The plain shunt type of motor is in general appearance very much like the series machine, and in the smaller sizes it would be somewhat difficult to distinguish one from the other by a casual inspection. The shunt machine gets its name from having its field coils connected in parallel, or in shunt as it is sometimes called, with the armature. The connections for a simple shunt-type motor and manual-type starting box are shown in Fig. 249. Instead of one circuit, as in the series motor, there are two in the shunt machine; namely, one through the armature and another through the field winding.

The field coils, Fig. 249, are connected directly across the line, therefore must be wound with a wire of comparatively small cross-section, so that the exciting current will be maintained at a value consistent with high efficiency, and also to prevent the coils from overheating. In this we find the most marked distinction between the series- and the shunt-type machines. In the series machine the field coils are wound with a comparatively small number of turns of large-sized wire, consequently have a low resistance, while in the shunt machine

the field coils are wound with a large number of turns of comparatively small wire and have a high resistance. In large-sized machines, 3.5 hp. and up, the motors can be distinguished by the size of the field leads, they being smaller than the armature leads on the shunt machines and the same size on the series machines. In the small machines, where the field and armature leads are the same size on both types, one type may be distinguished from the other by testing through the field coil with a lamp. When tested on the circuit of the machine's rated voltage a lamp connected in series with the field coil of

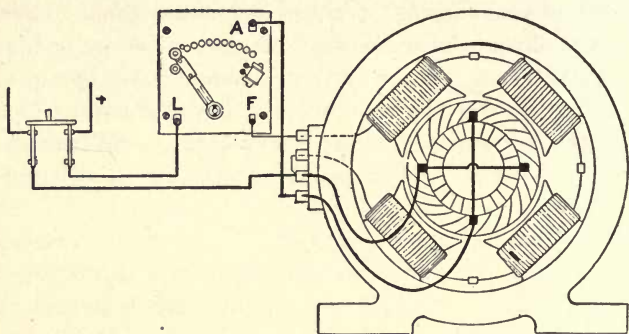

FIG. 249.—Connection diagram of shunt motor and starting box.

the shunt machine will glow dimly, but on a series machine the lamp will light brightly.

Torque of Shunt Motor Varies as the Armature Current.

—Since the field winding of a shunt motor is connected across the line, the magnetic density in the field poles will be practically constant irrespective of the load. Therefore the torque of a shunt motor varies directly as the current in the armature, and not as the square of the current, as in the series machine. In other words, if the current through the armature of a shunt motor is increased by two, the torque is also increased two times. Also, since the strength of the field pole is practically constant, the speed of the motor will be practically constant from no load to full load. In practice the variation is only about 5 to 10 per cent from no load to full load, the speed being higher at no load than at full load. Therefore, in a

shunt motor we have a machine the torque of which varies directly as the current in the armature and whose speed is practically constant. These two features make this type of motor applicable to a large number of drives where the starting conditions are not severe and where a constant speed is required over a wide range of load.

Compound-type Motors.—There are many drives that require practically a constant speed after the motor has been accelerated and where a strong starting torque is required. In other words, a motor is required that has speed characteristics of a shunt machine and the torque characteristics of a series machine. To meet such requirements, what is known as a compound motor is used, which is nothing more nor less than a shunt machine with the addition of a low-resistance winding on the field pole, connected in series with the armature. The connections for a simple type of compound motor to be started by a manual-type starting box are shown in Fig. 250. It will

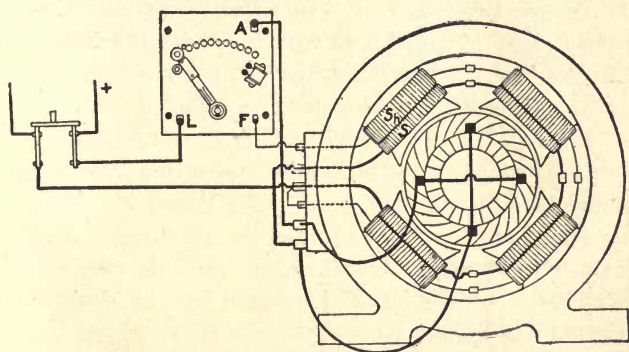

FIG. 250.—Connection diagram of compound motor and starting box.

be seen that the shunt winding, S_n , is connected across the line, the same as in Fig. 249, and the series-winding S is connected in series with the armature, as in Fig. 248. The same starting box is used on both the shunt- and compound-wound motors.

When compound motors are used on elevator service, the controller is usually arranged so that the series winding is in circuit only while the motor is coming up to speed. After the

load has been accelerated, the series winding is cut out of circuit automatically, thus converting the motor into a shunt machine during the running period. In this way the motor is made to act as a generator when the car is traveling in the down motion under heavy load to prevent the machine from racing. Cutting out the series winding during the running period also tends to make the motor run at a more constant speed under variable loads. Although a compound motor will not race as will a series machine under light loads, nevertheless its speed is not as constant under variable loads as a shunt machine. With the average compound motor the speed variations from no load to full load is in the neighborhood of 15 to 20 per cent. This, however, will depend upon the series ampere turns (turns \times amperes) on the polepieces. The greater the number of ampere turns in the series winding the greater will be the starting torque, as also the variation of the motor speed.

There are two ways of connecting compound motors—so that the series and shunt-field windings have the same polarity, and also so that the two windings will have opposite polarities. Where the two sets of field coils are connected so as to have the same polarity, the machine is called a cumulative compound motor; that is, the resultant field strength is the cumulative effect produced by the two windings. When the two windings are so connected that they oppose, the machine is called a differential compound motor, since the resultant field strength is the difference between that produced by the shunt- and the series-field windings.

The simple series, shunt and compound types, of direct-current motors cover in a general way motors for use on direct-current circuits. There are a number of other types, but they are only modifications of the three types discussed in the foregoing.

Effects of Armature Reaction.—In all direct-current machines the armature is an electromagnet with its north and south poles just as the field poles are, as was shown in Chapter XVI. Theoretically, the armature poles should be located mid-

way between the polepieces, but owing to the reaction between the two sets of poles the armature's neutral is caused to shift against the direction of rotation in a motor and with the direction of rotation in a generator. This shifting of the armature's neutral is one of the causes of sparking at the brushes in the simple types of direct-current machines and will be made clear in the following discussion:

In Fig. 251 is shown a schematic diagram of a direct-current machine having a ring-wound armature. If current is sent through the field coils, a magnetic field will be set up which will be uniformly distributed as in the figure. Leaving the field poles dead and passing current through the armature only with the brushes set midway between the polepieces, will cause magnetic poles to be produced in the armature midway between the main poles, as indicated in Fig. 252. The lines of force will be distributed similarly to that shown in the figure. The armature poles are really the resultant of two north and the two south poles. In following the direction of the current through the two halves of the armature winding an N and an S pole are produced in the upper half of the armature, likewise in the lower half. The N poles are produced on the right-hand side and the S poles on the left. This brings two like poles together at each brush; these poles repel each other, with the result that the lines of force tend to distribute as in the figure.

Comparing Fig. 251 with Fig. 252, it will be seen that the magnetic field set up by the armature is at right angles to that of the field poles. When current flows through the armature and field coils at the same time, as in Fig. 253, the N pole of the armature will repel that of the field poles and attract the S pole. Likewise the S pole of the armature will repel the main S pole and attract the N pole, with the result that, instead of the lines of force being uniformly distributed as in Fig. 251, the field will be distorted as in Fig. 253; that is, the lines of force are pushed away from one pole tip over onto the other. This action will vary with the load on the machine. If the load is small, the current in the armature is at a low value,

the field poles of the armature will be weak and have very little effect upon the main poles, consequently the line of force from the latter will be nearly uniformly distributed, as in Fig. 251. However, as the load comes on, the magnetic field of the armature will increase and its effect to distort the lines of force from the main poles will be increased. Therefore, with a vary-

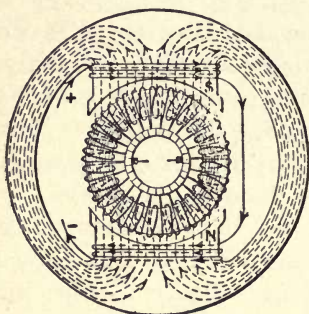

FIG. 251

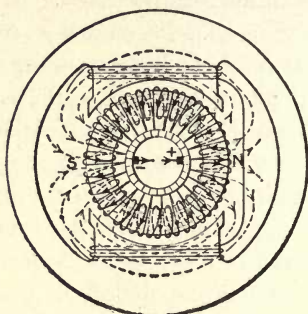

FIG. 252

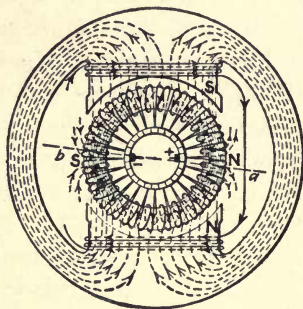

FIG. 253

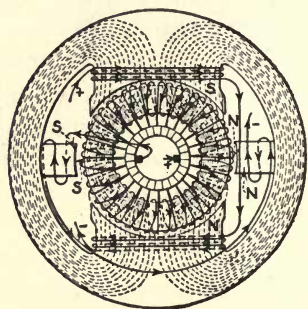

FIG. 254

FIGS. 251 to 254.—Shows magnetic flux distribution in direct-current machine.

ing load on the motor the distribution of the field from the main poles will be changing. With the flux uniformly distributed, as in Fig. 251, the correct position of the brushes would be as indicated in the figure, or what is known as the neutral point. When the motor is loaded as in Fig. 253, the neutral point has shifted to some position such as indicated by

ab due to the distorting effect of the armature poles. Consequently, the correct position of the brushes is not as shown in the figure, but on the line *ab*. From this it is seen that on the simple type of direct-current motor the neutral point shifts with the load, and this is one of the reasons for sparking at the brushes with changing loads on the machine.

Commutating-pole Machines.—To prevent this shifting of the neutral point or to at least hold a magnetic field at this position where the brushes are located, to assist in commutating an additional set of poles is frequently used in modern direct-current machines. These consist of a small pole called an interpole or commutating pole, located in between the main poles with a low-resistance winding connected in series with the armature as in Fig. 254. These poles are magnetized the same polarity as the armature poles, as indicated, and if of the same strength they will neutralize the effect of the armature poles and the neutral will remain in a fixed position. Since they are connected in series with the armature, the strength of their magnetic fields will vary as those of the armature. At light loads the current in the armature and interpole windings will be small, consequently the field poles of each will be weak. As the load increases, the current through the armature and interpole windings increases, likewise the strength of the field poles of both; consequently, if the interpoles are properly designed, they will neutralize the effect of the armature pole at all loads from no load to full load, making it possible to obtain sparkless commutation throughout the whole load range of the motor with the brushes in a fixed position.

Number of Interpoles Used.—An interpole for each main pole in the motor may be used, as in Fig. 255, *B* being the main poles and *A* the interpoles. However, to reduce the cost of construction, sometimes only one interpole is used for each pair of main poles, Fig. 256. In this case it is essential that the interpoles be so located that they are all the same polarity; that is, in Fig. 256 they would either be two north poles or two south poles. But the best practice is to use an interpole for

each main pole, and this is adhered to in a large percentage of cases, especially on medium-sized and large motors.

Interpoles are used on all three types of direct-current machines—series, shunt and compound—although as far as the external connections are concerned, the addition of the interpoles to the machine does not in any way complicate the connections over those for the simple types without interpoles. In

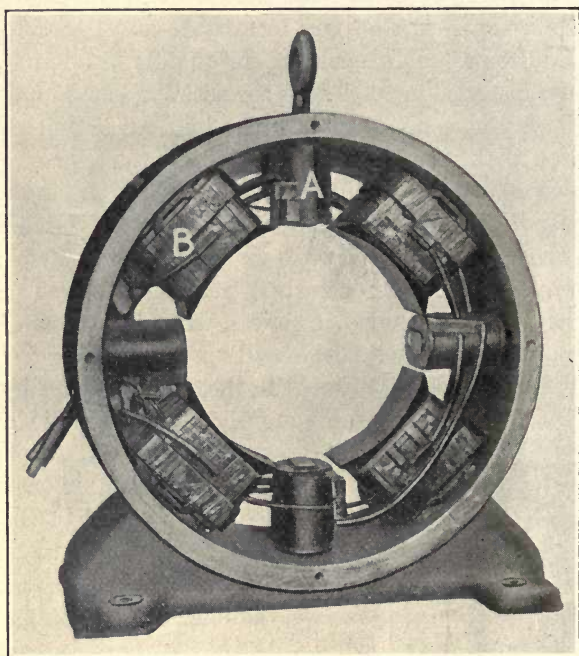

FIG. 255.—Four-pole interpole motor; one interpole for each main pole.

Fig. 257 are shown the connections for a four-pole series motor with interpoles, to be started from a manual-type starting box. These are the same as for the simple type of machine. On the shunt-interpole type only four leads are brought outside the motor and the connections to a manual-type starter are made as in Fig. 258. If it was desired to reverse the motor, the connection at the armature terminals would be interchanged,

which would reverse the direction of the current through the armature and the interpole windings. This is exactly as it should be, since if the direction of the current through the armature is reversed, the polarity is reversed, and if the interpoles are to remain the same polarity as the armature, the current through this winding must also be reversed.

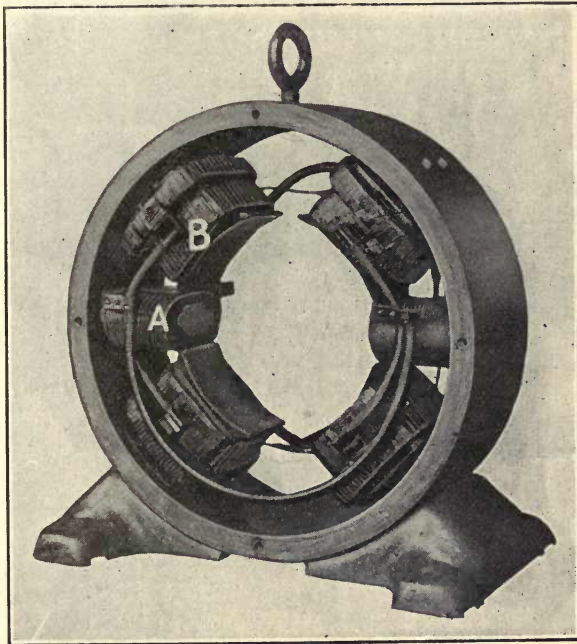

FIG. 256.—Four-pole interpole motor; one interpole for each pair of main poles.

In the compound-wound interpole machine the interpole winding is connected in the circuit between the armature and series winding. The connections to a manual-type starter are given in Fig. 259. It will be seen that, externally, these are the same as for a compound machine without interpoles. To reverse the direction of rotation of the motor, all that is necessary is to interchange the connections on the interpole and armature terminals outside the machine. This will reverse the

direction of the current through the armature and interpole windings as in the shunt machine. From the foregoing it is

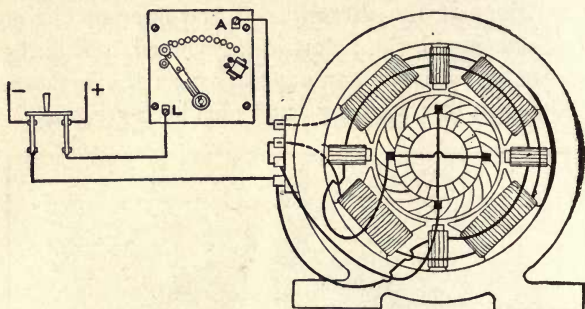

FIG. 257.—Connection diagram for series-interpole motor.

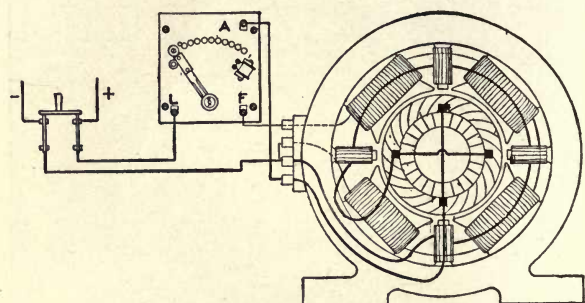

FIG. 258.—Connection diagram for shunt-interpole motor.

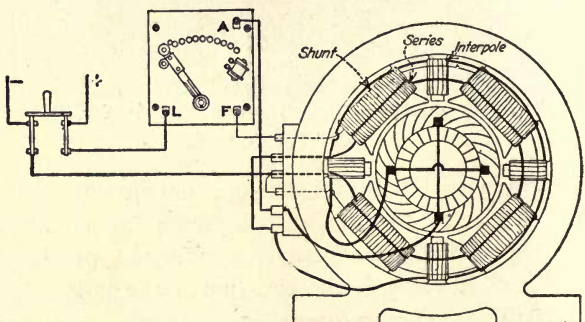

FIG. 259.—Connection diagram for compound-interpole motor.

evident that the connections of interpole machines to their starting device are the same as for those without interpoles.

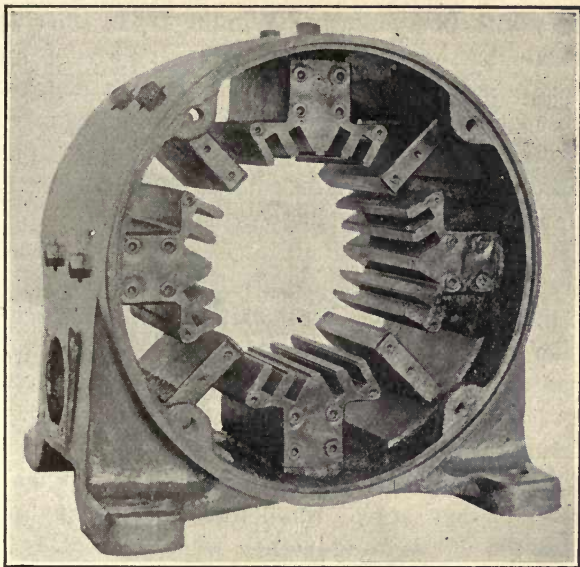

FIG. 260.—Field frame for compensated type motor.

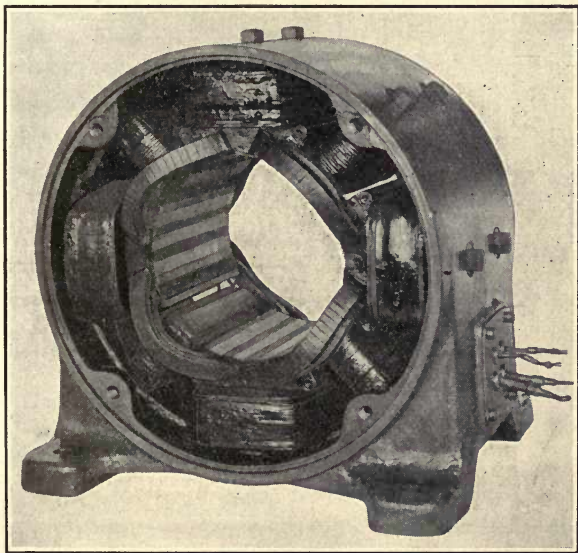

FIG. 261.—Field frame and windings for compensated-type motor.

Motors with Compensating Windings.—In some applications where the service conditions are very severe, interpole windings are not sufficient to give sparkless commutation. To meet these conditions the pole faces are slotted as in Fig. 260 and windings, known as compensating windings, placed in these slots, as in Fig. 261. This winding is of low resistance, as is the interpole winding. The current in the compensating windings flows in an opposite direction to that in the adjacent armature conductors, consequently if the compensating winding has the same number of conductors as the armature then the former will completely neutralize the effects of the latter. The armature may be looked at as an electromagnet with its N and S poles between the main poles, and the compensating coils a second winding on this electromagnet wound in opposition to the armature winding. Since the windings are in opposition, if they are of equal number of turns, one will neutralize the effect of the other when current is passing through them, and this is what the compensating windings in the pole faces does.

CHAPTER XVIII

STARTING RHEOSTATS AND CONNECTIONS TO DIRECT-CURRENT MOTORS

Starting Resistance.—Unlike a coil of wire in which the current is limited by the resistance of the circuit, the current in the armature of a direct-current motor is limited almost entirely by the counter-electromotive force generated in the conductors as explained in Chapter XVI. When the motor is running, the counter-e.m.f. generated in the armature is almost equal to the applied voltage; at standstill it is zero. The resistance of the armature is low, therefore a resistance must be connected in series with it at starting to limit the current to a safe value.

The resistance connected in series with the armature is usually of a value that will limit the starting current to about 125 per cent of that at full load. That is, if the full-load current of a motor is 20 amperes, the starting resistance will be of such a value as to limit the armature current to $20 \times 1.25 = 25$ amperes. When the armature starts to revolve, a counter-e.m.f. is generated and the current is reduced until the machine reaches a certain speed, which will be fixed by the load. At this point, if a section of the resistance is cut out, the current will be again increased, and this will raise the speed of the armature, causing the counter-e.m.f. to increase, and decrease the current to a value fixed by the load on the motor.

Action Taking Place when Motor Is Started.—Just what takes place when the motor is starting will probably be better understood by an example:

Assume a condition as shown in Fig. 262; the armature resistance $R_1 = 0.5$ ohm, and the starting resistance $R_2 = 8.5$ ohms, a total resistance of $0.5 + 8.5 = 9$ ohms. With 225 volts impressed on the circuit at the instant

of closing the switch the current I that will flow will equal the effective voltage E_e divided by the ohmic resistance R . That is,

$$I = \frac{E_e}{R} = \frac{225}{9} = 25 \text{ amperes.}$$

Note that the effective voltage is the difference between the line volts and the counter-e.m.f. When the motor is standing still, the counter-e.m.f. is zero, consequently the total line e.m.f. is effective.

The pressure E_1 across the motor terminals will equal the armature resistance R_1 times the total current I . Hence $E_1 = R_1 I = 0.5 \times 25 = 12.5$ volts, as shown. The difference between the line pressure E and E_1 is used up across the resistance, or $E_2 = E - E_1 = 225 - 12.5 = 212.5$ volts. E_2 is also equal to the starting resistance R_2 times the current I ; that is, $E_2 = R_2 I = 8.5 \times 25 = 212.5$ volts in either case.

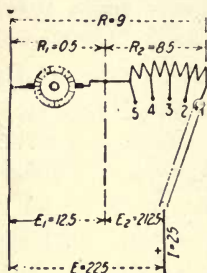

F.g. 262

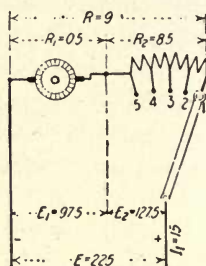

F.g. 263

FIGS. 262 and 263.—Diagram of armature and starting resistance.

As the motor speeds up, a back pressure (counter-e.m.f.) is generated in the armature, which decreases the current. Assume that the motor attains a speed that will cause a counter-e.m.f. e of 90 volts to be generated in the armature. The effective pressure E_e will equal the line volts E minus the back pressure e , or $225 - 90 = 135$ volts. The current I_1 , flowing through the armature under this condition equals the line voltage E minus the counter-e.m.f. e divided by the total resistance R , or

$$I_1 = \frac{E - e}{R} = \frac{225 - 90}{9} = 15 \text{ amperes,}$$

as indicated in Fig. 263.

The volts drop E_2 across the starting resistance is now equal to the product of the starting resistance R_2 and the current I_1 ; that is, $E_2 = R_2 I_1 = 8.5 \times 15 = 127.5$ volts, which leaves $E_1 = E - E_2 = 225 - 127.5 = 97.5$ volts across the armature. The volt drop across the armature due to resistance is equal to the armature resistance R_1 times the current I_1 equals 0.5×15

=7.5 volts. It will now be seen that this value (7.5 volts) plus the assumed counter-e.m.f. (90 volts) equals 97.5 volts, the new value calculated for the drop across the armature, as shown in the figure.

From the foregoing it will be seen that as the motor speeds up the current decreases and the pressure increases across the armature terminals. This continues to a point where the machine is just taking current enough from the line to carry the load, or, as assumed in this case, 15 amperes. Any further increase in speed would be followed by a further increase in the counter-e.m.f. and a decrease in the current. If the motor was starting under no load, it would run up to about full speed and the volts drop across the armature would be almost equal to the line pressure. On moving the starting-box arm upon the second point, the resistance will be reduced, say to 6 ohms, as shown in Fig. 264; now the ohmic resistance of the circuit equals $6+0.5=6.5$ ohms. When the arm was moved upon the second point of the starting resistance, the effective pressure equaled 135 volts; therefore, at this instant the current will increase to

$$I_2 = \frac{E_e}{R} = \frac{135}{6.5} = 20.77 \text{ amperes approximately.}$$

Under the new condition the voltage drop across the starting resistance will be $E_2 = R_2 I_2 = 6 \times 20.77 = 124.6$ volts, and the drop across the armature due to the resistance equals $R_1 I_2 = 0.5 \times 20.77 = 10.4$ volts. The total voltage impressed on the armature equals that due to resistance plus the counter-e.m.f. or in this case $10.4 + 90 = 100.4$ volts. The values are shown on the figure and total up to the line volts, which is as it should be.

This increase of potential and current to the armature will cause an increase in the speed, which in turn will raise the counter-e.m.f. and again decrease the current to a value where the torque will be just sufficient to carry the load. Assume that the current decreases to $I_3 = 16$ amperes. Then the volts drop across the resistance will equal $R_2 I_3 = 6 \times 16 = 96$ volts, and the drop across the armature will be the difference between this and the line voltage or $225 - 96 = 129$ volts, as shown in Fig. 265. The resistance of the armature will cause a drop of $R_1 I_3 = 0.5 \times 16 = 8$ volts, and the difference between this and the total drop equals the counter-e.m.f. or $129 - 8 = 121$ volts.

The foregoing shows how the starting resistance limits the current to the armature and how the e.m.f. gradually increases at the motor terminal as the speed increases. When the starting resistance is all cut out, full line pressure will be applied to the armature terminal, the motor will come up to full speed, and the counter-e.m.f. will be almost equal to the line volts.

The difference will equal the armature resistance times the current.

Starting-Current Curve.—If the points are taken on a straight line, as in Fig. 266 to represent the points on the starting box, and at these points vertical lines are drawn to represent the amperes to scale, a curve may be obtained that will represent the starting current. For example when the starting-box arm was placed on the first point, the current rose to 25 amperes, as shown by the vertical line drawn from point 1. As the motor increased in speed, the current decreased to 15 amperes before the starting-rheostat arm was placed on point 2. As the motor increased in speed, the current decreased to 16 amperes before the starting-rheostat arm was placed on

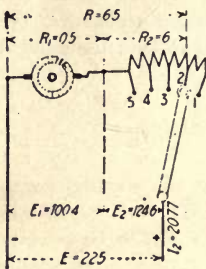

FIG. 264

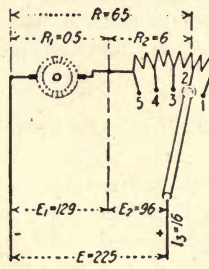

FIG. 265

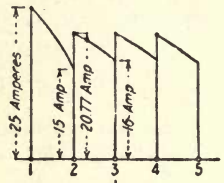

FIG. 266

FIGS. 264 and 265.—Same as 262, but with one point of resistance cut out.

FIG. 266.—Motor starting-current curve for Figs. 262 to 265.

point 2. This is shown by the decrease in the current curve between 1 and 2. At the instant of closing the circuit on point 2, the current increased to 20.77 amperes, also indicated on the vertical at point 2 in the figure. This rise in current caused a further increase in speed, and the current decreases to 16 amperes, as indicated on the vertical at point 3. When the arm is moved on point 3, the resistance will again be decreased and the current increased, all the time the speed of, and voltage at, the armature terminal is rising, until all the resistance is cut out and full voltage is applied to the armature terminal.

Starting Boxes.—Figs. 267 and 268 show two types of starting boxes in common use. In the figures R is a resistance

connected in series with the armature at starting by placing the arm *A* on contact *C*. This resistance is gradually cut out

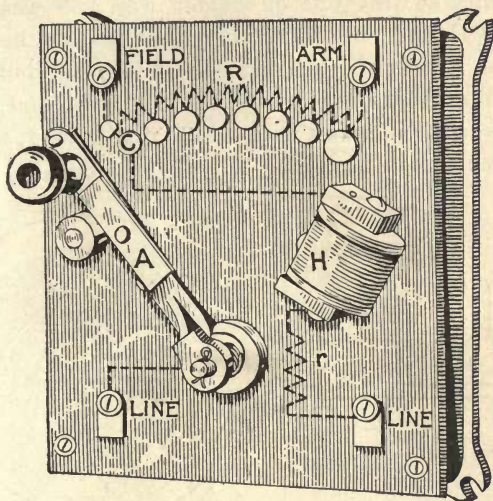

FIG. 267.—Four-terminal starting box.

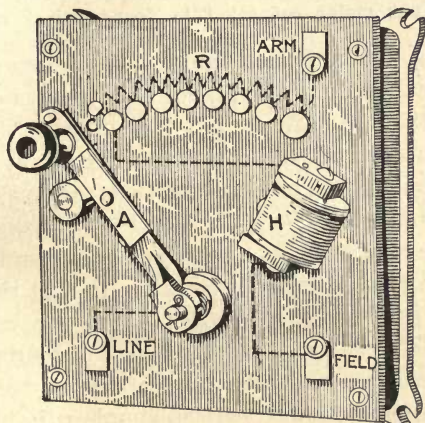

FIG. 268.—Three-terminal starting box.

by moving the arm across the contacts until it is on the extreme right-hand button. Coil *H* holds the arm in this position until

the switch is opened to shut down the motor, or the power fails for some cause. The connections for series, shunt and compound motors to the type of starter Fig. 268 was given in Chapter XVII and will be further discussed in this chapter. In this type of box the holding coil H is connected in series with the shunt field, where with the starting rheostat, Fig. 267, the holding coil is in series with a high resistance r , and across the line circuit as in Fig. 269.

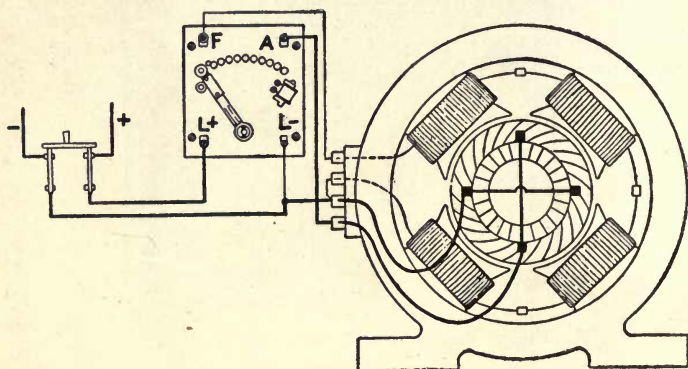

FIG. 269.—Shunt motor connected to four-terminal starting box.

Connecting Up a Series Motor.—It is general practice among electrical manufacturers, not only to label carefully the terminals of their apparatus, but to send with each piece of equipment instructions for connecting up as well as for its care and operation. These instructions are usually accompanied by a well executed picture of the motor, showing how the terminals are located, each terminal being carefully marked and connected to a starting box similar to that shown in Fig. 270, which represents a series motor. However, as the terminals of various makes of motors may be brought out differently, a representation of the connections of one make may not apply to another, unless certain simple rules are followed. When it comes to this, the picture may be dispensed with and a diagram used as in Fig. 271. There is one thing necessary, the diagram must represent the motor it is used for; that is, if the motor is series wound, the diagram must represent a series

motor as the one in Fig. 271; if it is shunt wound, it must represent a shunt motor, etc.

To connect up a motor from a diagram, first determine which are the armature and which the field terminals, and what kind of a motor it is, either by inspection or by testing. Assume a condition as in Fig. 270, where the two center terminals represent the armature circuit; as can be seen, they come from the brushes and are marked A and A_1 . The two outside terminals are the field and are marked F and F_1 .

A good practice in connecting up a motor from a diagram is to start from one side of the switch and work around to the opposite side. In this case, start from the positive side of the

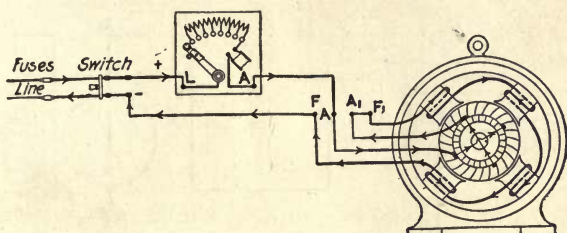

FIG. 270.—Series motor connected to starting box.

switch, which in Fig. 271 runs to the terminal marked L (sometimes marked "Line") on the starting box. After making this line connection, next in order will come the other terminal on the starting box, which is marked A . By referring to Fig. 271, it will be seen that one wire runs from this terminal to one of the armature terminals marked A , although in this instance, it could be any terminal on the motor as the machine is series connected and there is but one circuit through it. This is true only for the series motor, therefore, it is best to make a practice of connecting the machine according to the sketch. The following can be laid down as a hard-and-fast rule for any motor:

Connect terminal A (sometimes marked "Arm") on the starting box to one of the armature terminals only on the motor and this part will always be right. Next connect the other terminal of the armature to one of the field terminals,

which, in Figs. 270 and 271, are shown A_1 to F_1 , although A_1 could be connected to F . Finally, connect the remaining terminal F on the motor to the negative side of the switch. Now if the connections are traced out in Figs. 270 and 271, it will

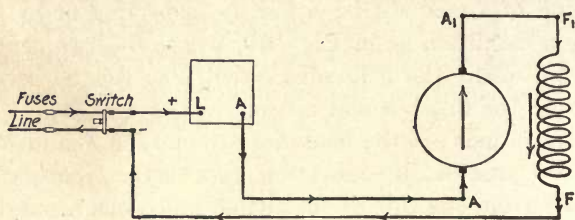

FIG. 271

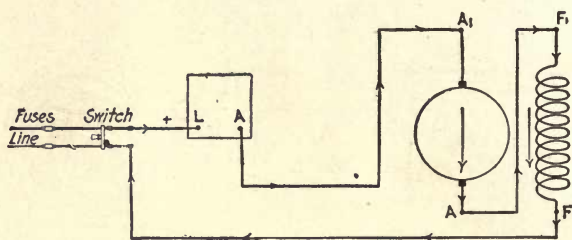

FIG. 272

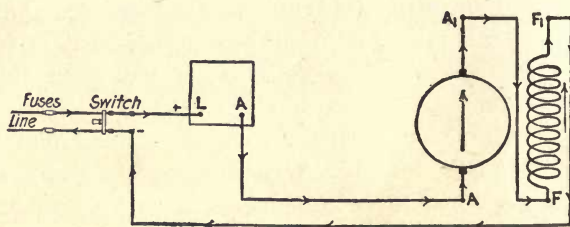

FIG. 273

FIGS. 271 to 273.—Diagrams of series-motor connections.

be seen that they both run the same; that is, from the positive terminal on the switch to the L terminal on the starting box; from A on the starting box to the armature connection A ; from the armature terminal A_1 to the field terminal F_1 and from the remaining field terminal F to the negative side of the switch.

In a diagram, such as Fig. 270, the connections may be so

shown as to produce a definite direction of rotation, while that in Fig. 271 does not indicate any particular direction. After the motor has been connected up, however, and is working properly, all that is necessary in order to reverse the direction of rotation, is to interchange either the armature or the field connections, as in Figs. 272 and 273. By tracing out the current, it will be seen to flow as indicated by the arrows. In either case, the connections in Figs. 272 and 273 will give a different direction of rotation from that in Fig. 271.

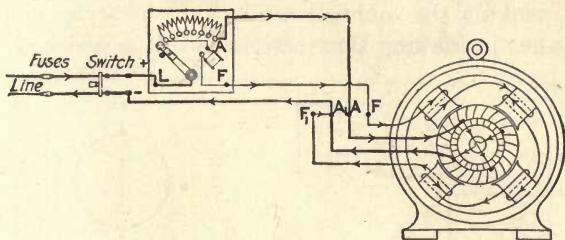

FIG. 274.—Shunt motor connected to starting box.

Connecting Up Shunt Motors.—What has been applied to the series motor can also be applied to any type of motor. In Fig. 274 is shown a shunt motor connected to a starting box. Every terminal on the machine and starting box is indicated in its proper location, but, as in the series motor, these connections can be shown in a diagram, as in Fig. 275. The starting box for the shunt motor, however, has three terminals on it, the object being to connect the field across the line at the instant of starting. This will be made clear by referring to Fig. 274. When the arm on the starting box is moved to the first contact of the starting resistance the field current will flow as indicated by the arrowheads; that is, direct from the line through the no-voltage release coil on the starting box to field terminal *F* on the motor, and through the field back to the line, thus applying full-line voltage across the field terminals at starting. This produces a maximum field strength, which develops a maximum starting torque for a given current in the armature. By tracing out the armature current with the starting-box arm on the first contact, it will be seen that all the resistance is in

series with the armature and the current flows as indicated by the arrowheads. As the arm is moved over toward the no-voltage release coil, the resistance is cut out of the armature circuit and cut in the field. The starting resistance in series with the field has little effect, for the resistance of the field is so high compared with the starting resistance, that it is almost negligible. This additional terminal F' on the starting box (sometimes marked "Field") does not greatly increase the complications of the connections, although more care should be taken in making the connections than in the series motor.

Mistakes in Making Connections.—In the series motor the

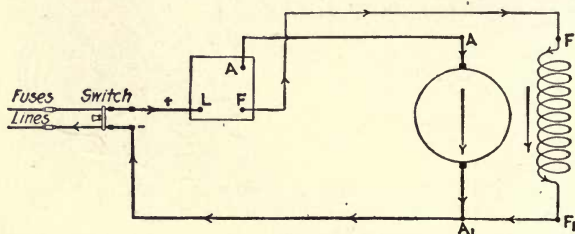

FIG. 275.—Correct diagram of shunt-motor connections.

armature connections on the starting box could be connected to any terminal on the motor and be connected right; but not so for the shunt machine, the armature terminal on the starting box must connect to one of the armature terminals on the motor, and the terminal on the starting box marked F' (or Field) must always be connected only to one of the field terminals of the motor, as indicated in Figs. 274 and 275, the remaining armature and field terminals being connected together and directly to the line switch. Care should be taken to have the motor connected properly before attempting to start it, as serious results may occur from wrong connections. For instance, if the connections were made as in Fig. 276, the field terminal F' on the starting box is connected to the armature terminal A on the motor and the armature terminal A on the starter to the field terminal F' on the motor. If the motor is started under these conditions, the no-voltage coil on the starting box will become very hot, and if left in circuit long

enough, it would be burned out. If the motor was starting under load, the probabilities are that the coil would be burned out almost instantly.

Another mistake is that shown in Fig. 277; that is, the field terminal on the starting box is connected to the armature and

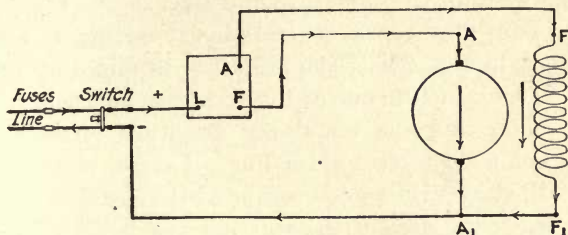

FIG. 276

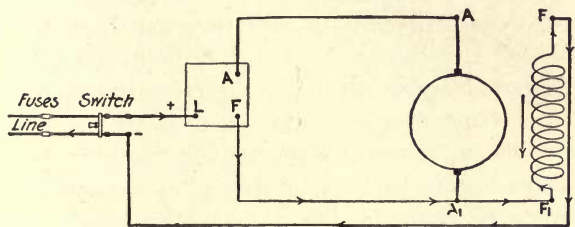

FIG. 277

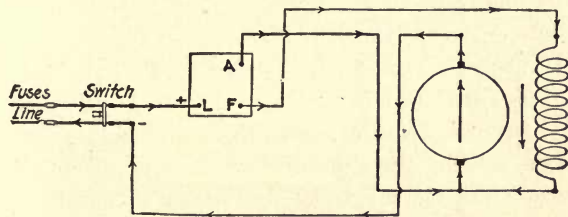

FIG. 278

FIGS. 276 to 278.—Incorrect diagrams of shunt-motor connections.

field on the motor, and the field connection on the motor to the line switch. By tracing out the current it will be seen that the fields are across the line, but both armature terminals are connected to the starting box. This will give full voltage across the field, but zero voltage across the armature, and the motor

will not start; although, if the arm of the starting box is thrown over against the no-voltage release coil, it will be held there. No serious results would occur from this connection. Such mistakes are not likely on the large motors, as the field terminals on the starting box and motor are too small to receive the large wires of the armature and line.

One of the most common errors in connecting up a motor is that shown in Fig. 278. The armature terminal on the starting box is connected to one of the armature and field terminals on the motor and the remaining armature terminal of the motor is connected direct to the line. A shunt motor thus connected will start with a good torque at the instant of starting; that is, when the arm of the starting box is moved upon the first contact the current can flow from the positive side of the line through the field and the armature and back to the opposite side of the line and give full field strength. The armature current also flows in the direction indicated, and as far as the starting torque is concerned, it will be about the same as that when the motor is connected properly. As soon as the armature begins to turn, it generates a counter-electromotive force. Since the field is in series with the armature the counter-electromotive force will decrease the effective voltage across the field and, as the starting resistance is cut out, and the motor speeds up, the field becomes weaker and the motor races. If the motor is started under load there is danger of the starting resistance being burned out, for instead of the starting current becoming less as the motor comes up to speed it increases, and by the time two or three points of the resistance are cut out, the starting box is very hot or the fuse has blown.

Checking Connections.—After the motor has been connected, it is advisable to make a test to see that there have been no mistakes made in making the connections. This can be done as follows:

After everything is in readiness to start, disconnect the armature connection on the starting box as in Fig. 279, then close the switch and bring the starting-box arm on the first

point. If the motor is connected properly, as in the figure, the field circuit will be complete and will be indicated by a spark if the starting-box arm is allowed to drop back to the off position or the switch is opened. Care should be taken not to open the circuit too quickly, as this induces a very high voltage in the field. If the arm on the starting box is brought over against the no-voltage release coil, it will be held in this position until the switch is open or the arm forced away from the coil.

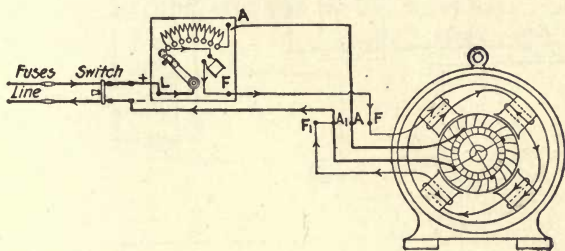

FIG. 279

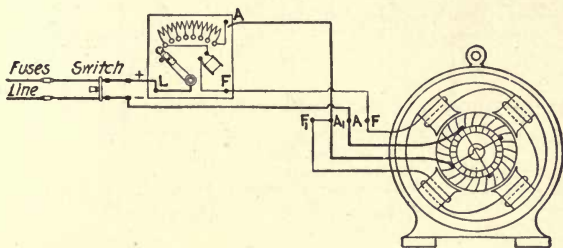

FIG. 280

FIGS. 279 and 280.—Armature lead disconnected from starting box to test motor connections.

With any other combination of connections, the field will be open-circuited if the armature connection on the starting box is open, as in Fig. 280, which is the same connection as in Fig. 278. This will be indicated by the absence of a spark when the starter arm is pulled back from the first contact to the off position, although an open-circuit in the field may be tested for in the same way if the motor is connected up properly.

Connecting up a shunt motor from a diagram, as in Fig. 275, involves no particular direction of rotation, but, as in the series machine, after the motor has been connected correctly, and is found to operate properly, the direction of rotation may be reversed by interchanging either the armature or the field connections, as in Figs. 281 and 282, respectively. Fig. 281 shows the armature connections interchanged; Fig. 282,

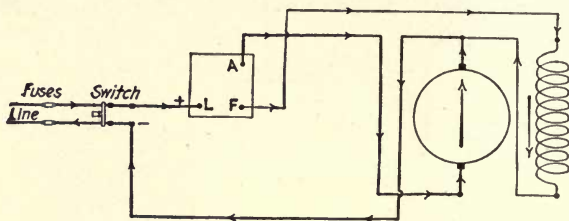

FIG. 281

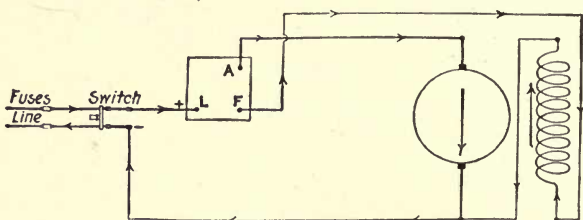

FIG. 282

FIGS. 281 and 282.—Connection changed from those in Fig. 275, to reverse direction of rotation.

the field connections interchanged. The connections in Figs. 281 and 282 will cause the armature to turn in the opposite direction to that shown in Fig. 275. It will be seen that although the current has a different direction in the field and armature in Figs. 281 and 282, the motor is connected the same as in Fig. 275, and this is the only possible connection that can be made and have the motor operate properly.

A mistake that is often made in attempting to interchange the armature connections to reverse the direction of rotation is to interchange the armature connection with that of the line, which is the same as that in Fig. 278, and will, therefore, pro-

duce the same results as explained for that connection. Care should be taken always to remove the jumper between the field and armature connections and to connect it to the opposite armature connections with the line wire. This mistake is often made on machines which have their leads connected to three terminals, as in Fig. 283. Under these conditions, the easiest way to reverse the machine is to interchange the armature leads at the brushes although either the armature or the field leads may be interchanged at the terminals inside the field frame.

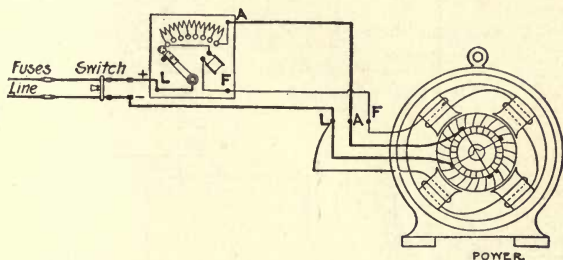

FIG. 283.—Shunt motor having only three terminals, connected to starting box.

Connecting Up Compound Motor.—The connections of a compound motor are not necessarily more complicated than those of a series or shunt machine when the compound machine is viewed as only a series motor with a shunt-field winding on it.

To illustrate, consider Figs. 284, 285 and 286, showing respectively the connections of series-, shunt- and compound-wound machines. By tracing out the armature circuit in Fig. 286, which is from the positive side of the switch to the *L* connection on the starting box, from the *A* connection on the starting box to the *A* connection on the motor, and through the armature and field to the negative side of the line as indicated; this is found to be identical with the series-motor circuit, as shown in Fig. 284. Hence, when making the connections of a compound motor, if the armature and series field are connected as a series machine, they will always be right, and all that will be left to consider is the shunt field. If the latter

circuit is traced out in Fig. 286, it will be seen to run from the F connection on the starting box to the shunt field ($Sh. F_1$) connection on the motor and from the $Sh. F$ connection to the line; this being identical with the field connection in Fig. 285, which bears out the statement that the compound

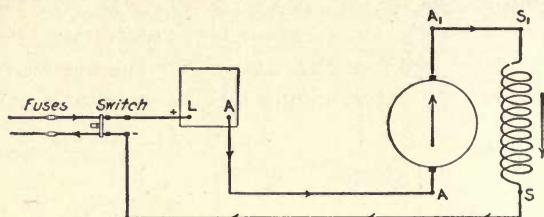

FIG. 284.—Diagram of series motor.

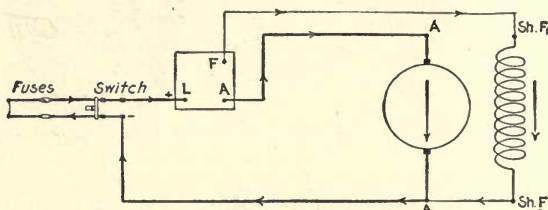

FIG. 285.—Diagram of shunt-motor.

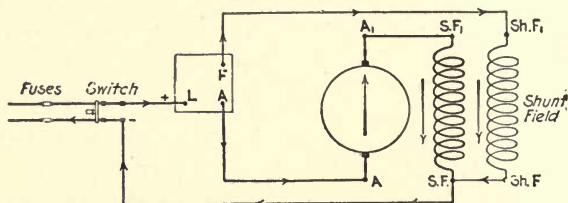

FIG. 286.—Diagram of compound motor.

machine is nothing more nor less than a series machine with a shunt field on it.

Care should be taken to determine which is the series and which is the shunt field on the machine before making the connections, for if the series field is connected in shunt the no-voltage coil will be burned off the starting box or the fuse

blown. The series field is always shown on the diagram in heavy lines, while the shunt field is shown in light lines. On all compound motors, except small sizes, the series-field leads are much larger than those of the shunt field. In the small machines, when the shunt- and series-field leads are the same size, the two fields may be determined by testing with a lamp. The lamp will burn brightly through the series field and dimly through the shunt field. After the motor has been connected it is advisable to make a test to determine if the connections have been made correctly. This can be done in the following way:

Disconnect the armature connection on the starting box, likewise the armature connection on the motor, as shown in

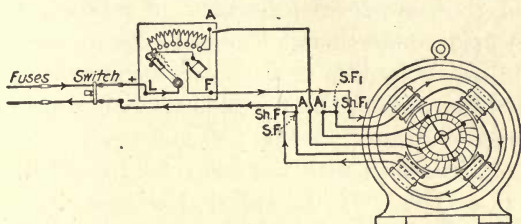

FIG. 287.—Armature lead disconnected to test connections of compound-wound motor.

Fig. 287; then close the switch and move the starting arm to the first contact, as shown by the dotted line. If the connections have been made properly, and the switch is opened or the starting-box arm allowed to drop back to the off position, a severe spark will occur. If there are doubts as to which field has been connected in shunt, do not move the starting-box arm upon the first contact, but connect a lamp as shown in Fig. 288. If the shunt field is connected correctly the lamp will burn dimly and a severe spark will occur when the circuit is open. If the series field has been connected in place of the shunt the lamp will burn to full brilliancy and no spark will occur when the circuit is broken.

Testing Polarity of Series- and Shunt-field Windings.—After the connections have been tested and found to be correct, the next thing to test for is the polarity of the shunt- and

series-field coils, which should be the same. To do this, disconnect one side of the shunt field as in Fig. 289, then start the motor as a series machine and note the direction of rotation. *Do not cut out the starting resistance as the motor will reach a dangerous speed.* Stop the machine and connect the shunt field, then short-circuit the series-field connections as shown by the dotted line in Fig. 290 and start the motor again. If the armature turns in the same direction as before, the series- and shunt-field windings have the same polarity. If the direction of rotation is opposite to that produced by the series field the series- and shunt-field coils are of opposite polarity. To remedy this, if the shunt field gives the desired direction of rotation, interchange the series-field leads. If the series field gives the desired direction of rotation, interchange the shunt-field connections. The polarity of the series- and shunt-field coils may also be tested by taking the speed of the motor, first as a compound machine, then short-circuit the series field as indicated in Fig. 290 and again take the speed. If the speed increases with the series field short-circuited, the polarity is correct. If the speed decreases, the polarity is wrong.

Series- and shunt-field coils of opposite polarity in a compound motor may produce several effects, depending upon the strength of the series field. It may cause a slight increase only in speed from no load to full load, but in most cases it will cause one of the following effects:

(1) The motor may start and operate satisfactorily under no load. When the load is put on it may suddenly increase in speed and spark badly at the brushes, causing the fuses to blow or throw the circuit-breaker.

(2) The motor may decrease in speed to the point where the fuses will blow, and if not properly fused may stop, reverse and run in the opposite direction; this will be accompanied by severe sparking at the brushes.

(3) The motor may start in one direction and when the starting resistance is partly cut out it will stop, reverse and run in the opposite direction.

(4) The motor may fail to start, the armature usually making slight efforts to turn in one direction and then in the other

If the series-field coils are of the right proportions, a constant speed will be had from no load to full load. This condition is seldom, if ever, found except in motors designed to accomplish this purpose.

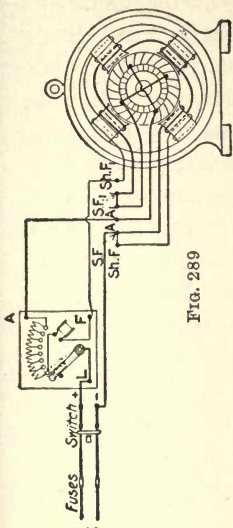

FIG. 288

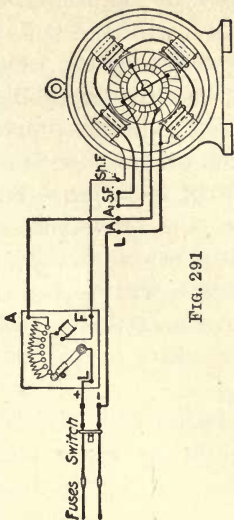

FIG. 289

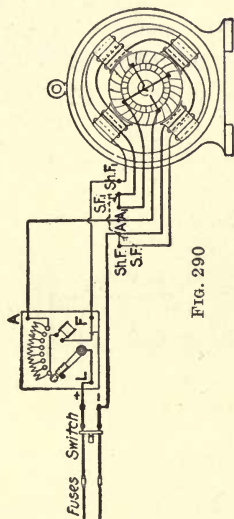

FIG. 290

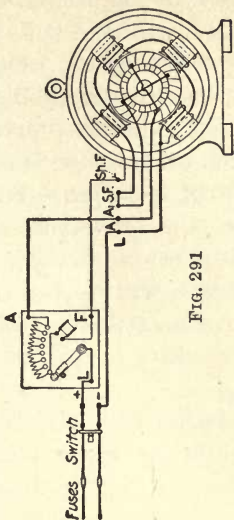

FIG. 291

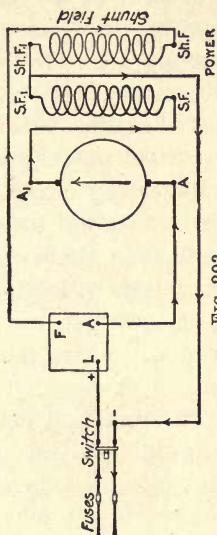

FIG. 292

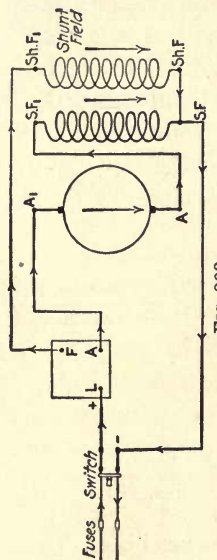

FIG. 293

FIGS. 288 to 293.—Diagrams of compound-motor connections.

Several of the electrical manufacturers connect one terminal of the series- and shunt-field coils together inside the machine, after first determining the correct polarity of the field coils. This leaves but five terminals coming to the outside, as in Fig. 291, which eliminates the necessity of finding the correct polarity when the machine is connected up.

Reversing Direction of Rotation.—To reverse the direction of rotation of a compound motor, it is usually best to interchange the armature connections, as in Fig. 292. By comparison with Fig. 286 it will be seen that the direction of the armature current in Fig. 292 is opposite that in Fig. 286, which will cause the armature to turn in the opposite direction.

The direction of rotation may also be reversed by interchanging the field connections where both of the series and shunt terminals have been brought to the outside. Care must be taken to interchange both the series- and shunt-field connections as indicated in Fig. 293. If compared with Fig. 286, it will be seen that the current is in the same direction in both cases in the armatures, but opposite in the field windings.

Connecting Up Interpole Machines.—What has been said in reference to the simple series, shunt and compound machines also holds true for the same class of machines with interpoles. Fig. 294 shows the connections of a shunt-inter-

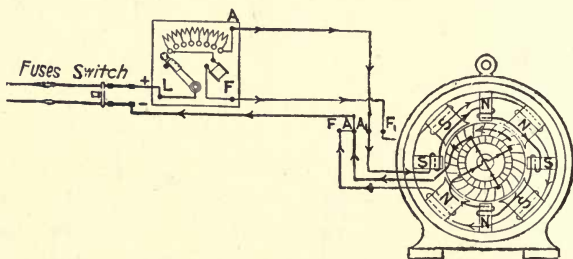

FIG. 294.—Shunt-interpole motor connected to starting box.

pole machine. The external connections are the same as those in Fig. 274, and the only change in the internal connections is the interpole winding connected in series with the armature. One side of the interpole winding is always connected to one

side of the armature, with one armature and one interpole connection brought to the outside terminals.

Care should be taken to have each interpole of the proper polarity, which should be the same as the following main pole. This condition is shown in Fig. 294, for the direction of rotation indicated. Usually, when the machine leaves the factory the interpole winding is connected for the correct polarity; therefore on most new machines this problem is already solved, and the connections can be made to the starter and switch the same as for a motor without interpoles.

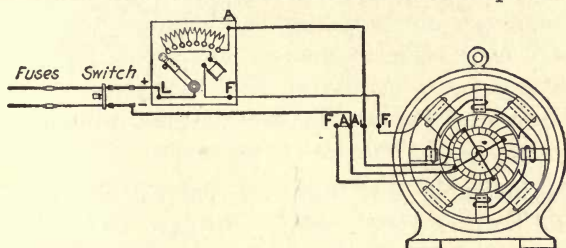

FIG. 295.—Shunt-interpole motor; interpole winding disconnected.

After a machine has been taken apart for repairs, unless the connections have been carefully marked, it will be necessary to test the interpoles for polarity when assembling. A practical way to do this is, first, to connect the machine in shunt, as in Fig. 295, and see that it is operating properly, with all the starting resistance cut out. The motor may then be shut down and one side of the shunt field opened. After carefully marking the position of the brushes on the bearing bracket and rocker arm, shift them three or four segments around the commutator; then connect the interpole winding in series with the armature and start the motor again, this time being careful *not to cut out the starting resistance* as the motor will race and may reach a dangerous speed. Note the direction of rotation, and if the armature turns in the same direction as that in which the brushes are shifted, the interpole polarity is correct. If it turns in the opposite direction the polarity is wrong. To remedy this, interchange the armature and interpole connections as shown in Fig. 296 and test the machine again. This time, if everything has been done cor-

rectly, the rotation should be the same as the direction in which the brushes were shifted. After the desired condition has been obtained, open the switch and shift the brushes back to their positions and connect up the shunt field to give the motor the desired direction of rotation.

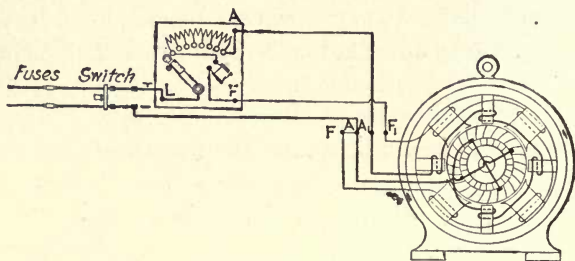

FIG. 296.—Same as Fig. 294, but with interpole terminal connection changed at the armature.

If the interpole is of the wrong polarity, the brushes will spark and burn and the machine will have a marked decrease in speed with an increase in load.

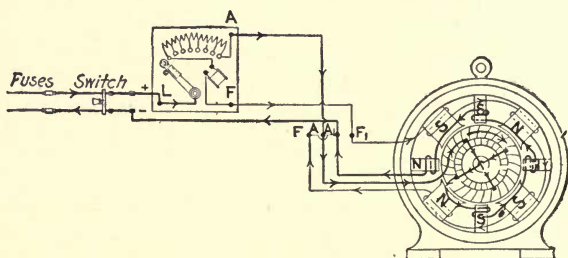

FIG. 297.—Armature and interpole connections changed from those in Fig. 294, to give reverse direction of rotation.

Interchanging the shunt-field connections is usually the easiest way to reverse an interpole shunt motor, although the direction of rotation can be reversed by changing the terminals of the armature circuit, which must include the interpole winding as in Fig. 297. By comparing the direction of the currents in the armature and interpoles in Figs. 297 and 294, they will be found to be opposite, as indicated by the arrowheads.

CHAPTER XIX

THREE-WIRE SYSTEMS AND HOW THEY MAY BE OBTAINED

Voltages for Direct-current Circuits.—Since the two most extensive uses of electricity are for power and lighting, the decision on what system to use must be based upon the requirements of such services. In industrial direct-current work, the highest voltage at which motors operate is usually between 500 and 600 volts, although in electric-railway work voltages up to 5,000 have been used. Lamps, on the other hand, give the most satisfactory results when designed to operate in the neighborhood of 120 volts. When motors and lamps are to be supplied with power from the same service, it is almost compulsory to make the best lamp voltage the controlling element. No matter how desirable it might be to operate the motor load at 500 volts, it would be out of the question to use lamps for such a voltage without operating them in series groups, which, to say the least, is very unsatisfactory. If the motor voltage were reduced to 250, it would be possible to use lamps on the service, but not advisable. The most satisfactory method is to use lamps which operate at from 110 to 125 volts. It has, however, the disadvantage of requiring a line wire designed to carry twice as much current as at the higher voltage, which even for the lighting load is a serious handicap, but which for large power service makes it almost prohibitive.

To meet these conflicting conditions a method of distribution known as the three-wire system was evolved, which differs from the ordinary circuit, requiring two wires, in the fact that it makes use of three wires as its name implies. The principle upon which it was developed may be explained as follows:

Assume that it is required to use one hundred 60-watt 120-volt lamps to furnish a certain amount of illumination. The total amount of power to be supplied would be $W = 100 \times 60 = 6,000$ watts. If the load were supplied from a 120-volt two-wire system, as illustrated in Fig. 298,

the current required would be $I = \frac{W}{E} = \frac{6,000}{120} = 50$ amperes. If the voltage drop in the line M were to be restricted to 3 volts, its resistance would have to be $R = \frac{E}{I} = \frac{3}{50} = 0.06$ ohm, and the power lost in it would be $I^2 R = (50)^2$

$\times 0.06 = 150$ watts. Suppose, now, that the lamps were arranged as shown in Fig. 299; that is, that they were divided into fifty groups of two lamps in series. In that case it would be necessary to impress a voltage of 240 volts across the mains in order to make the lamps burn at their

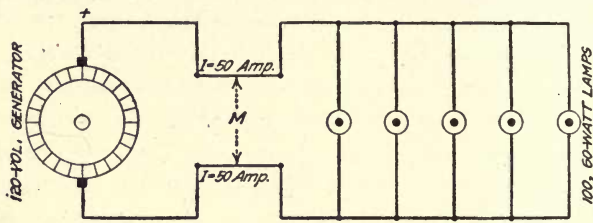

FIG. 298.—Five lamps connected in parallel on two-wire circuit.

proper brilliancy. The total load would be the same, and we should therefore have $I = \frac{W}{E} = \frac{6,000}{240} = 25$ amperes, or half the current required at 120 volts. The difference arises from the fact that at 120 volts we have

100 paths through the lamps, each taking 60 watts, or $\frac{60}{120} = 0.5$ ampere;

whereas at 240 volts we have only 50 paths, each taking that current. If we were to allow the same line loss in the latter case as in the former,

we should have $(25)^2 \times R = 150$ watts, from which we find $R = \frac{150}{(25)^2} = 0.24$

ohm, a value four times as great as required before. The voltage drop in the line would be $E = IR = 25 \times 0.24 = 6$ volts, twice the value at 120 volts; but since the lamps are arranged two in series, a drop of 6 volts across the two is equivalent to a drop of 3 volts across each, the same as on the 120-volt circuit. Consequently, the resistance of the line could be increased fourfold without changing either the loss in it or the voltage drop to the lamps. The cross-section of the wire could therefore be made one-quarter of what it was, which means that only one-quarter of the weight of copper would be required, with a corresponding reduction in the cost of the installation. It may be pointed out here that a

reduction to one-quarter of the cross-section is equivalent to halving the diameter.

An arrangement of lamps such as that indicated in Fig. 299 could be operated satisfactorily if they were always required in pairs, but otherwise the scheme would not be practicable, since by turning out one lamp the other would also be extinguished. There are additional drawbacks to the series system in that the lamps must be identical, or they will not burn at the same brilliancy, a short-circuit in one results in double normal voltage being impressed upon the other, causing it to burn out, and both lamps are extinguished if either one of them fails.

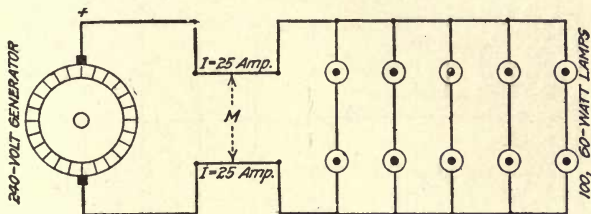

FIG. 299.—Ten lamps connected series parallel on two-wire circuit.

Three-wire System.—These undesirable features may be eliminated by the use of a method such as that represented in Fig. 300, which is the typical diagram of a three-wire system. In stead of using a single source of 240 volts, two sources of 120 volts each are connected in series and a connection is made at the junction a , and run as a third main wire to the load. It is commonly referred to as the neutral wire or merely as the neutral of the system, and the other two lines are known as the outside wires. Thus, in Fig. 300, N is the neutral and A and B are the outside wires. It will be noticed that a voltage of 240 volts exists between the outside wires A and B , but that between either outside and the neutral is only 120 volts. Also that the neutral is negative with reference to one outside wire and positive with reference to the other.

In the foregoing it was shown that in a three-wire system three sources of voltage are available, two of which have the

same value, and the third being equal to the sum of the other two. A 120- to 240-volt system are the approximate values used almost universally for such service. It is, however, entirely feasible to employ exactly the same type of distribution for any other set of voltages, higher or lower, that might be required in special cases, and whatever follows in regard to the 120- to 240-volt system is equally applicable to them.

To bring out clearly the underlying principle of the three-wire system, let us first give our attention to two two-wire systems furnishing current to lamps, as indicated in Fig. 301.

Let us assume that we have two generators G_1 and G_2 , each supplying 120 volts and each furnishing current to twelve

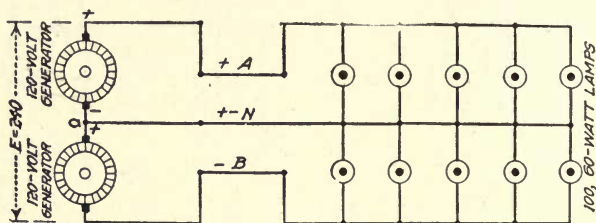

FIG. 300.—Ten lamps connected on three-wire circuit.

500-watt lamps, making the load on each $12 \times 500 = 6,000$ watts or $\frac{6,000}{120} = 50$ amperes when all the lamps are turned on.

The direction of the currents through the mains A , X , Y , and B is that indicated by the arrowheads. For convenience the currents are designated I_A , I_X , I_Y and I_B respectively.

Assume that the two wires X and Y are supplanted by a single wire N as in Fig. 302. The current in this wire will be the sum of the currents in X and Y . Referring to Fig. 301, we find that the current in each is 50 amperes, but that the current in X is from c toward a , whereas that in Y is from b to d . The resultant current is therefore zero, since one current is positive and the other negative; that is, no current flowing in N .

Since the current in N is zero, it would appear that the neutral could be dispensed with. This is, however, true only

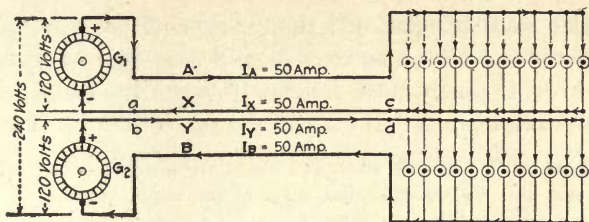

FIG. 301

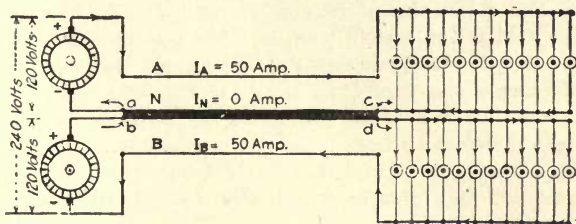

FIG. 302

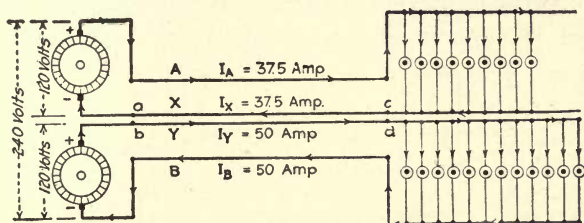

FIG. 303

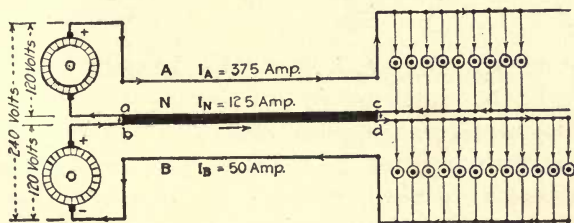

FIG. 304

Figs. 301 to 304.—Shows how three-wire system can be developed from two two-wire systems.

when the load is balanced; that is, when there are just as many lamps connected between A and N as there are between B and N or, to put it more accurately, when the loads are such that the current in A has exactly the same value as that in B .

To show what happens when the loads are not the same, let us go back to Fig. 301 and assume that three of the lamps between A and X are turned off, leaving only nine in service between these mains as in Fig. 303. The current in A and X then is $\frac{9 \times 500}{120} = 37.5$ amperes, whereas that in Y and B remains at 50 amperes as before. These conditions would also hold if the system were connected as in Fig. 302, and we would have that $I_A = 37.5$ amperes, $I_B = 50$ amperes and that I_N is equal to the difference of the currents I_X and I_Y of Fig. 303; namely, $50 - 37.5 = 12.5$ amperes, whose direction will be that of the larger current, that is, I_Y , and will therefore be from b to d as in Fig. 304. If, on the other hand, the load between N and B is made smaller than that between A and N , we would find I_X to be greater than I_Y and the current through N to be from c to a .

The extreme case is that in which all the lamps on one side are turned off while all those on the other are burning. Thus, let us suppose that the lamps between N and B have

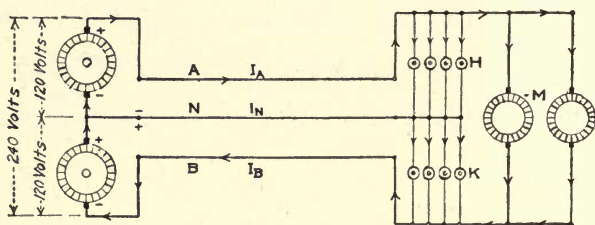

FIG. 305.—Lamps and motors connected to three-wire system.

been turned off. Then $I_B = 0$ while I_A remains 50 amperes, and I_N will be equal to $I_A - I_B = 50 - 0 = 50$ amperes. That is, when the system is loaded on one side only, the current through the neutral has the same value as that through the outside wire to which the load is connected. This is the maximum value which the current in the neutral can have; as lamps are lighted on the unloaded side the current in the neutral is decreased, until when the loads are balanced no current flows through it.

The manner in which these currents are then distributed in the three conductors, under various conditions of loading, is illustrated graphically in Figs. 306 to 311. The mains are indicated by large pipes which are connected together by smaller pipes *L* which represent the lamps. The direction of

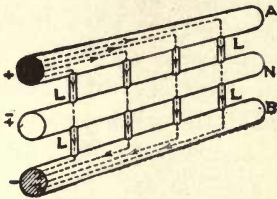

FIG. 306

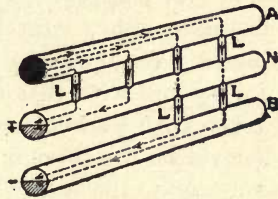

FIG. 307

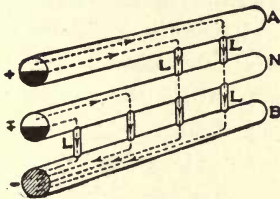

FIG. 308

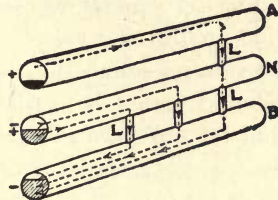

FIG. 309

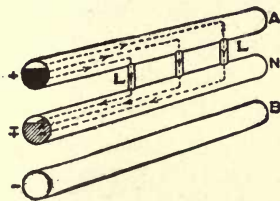

FIG. 310

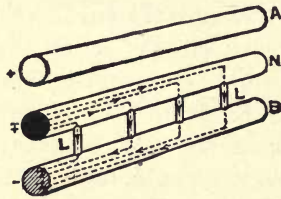

FIG. 311

FIGS. 306 to 311.—Show current distribution in three-wire system.

the currents is indicated by the arrows. Currents flowing away from the reader are represented by the black sections and those flowing toward the observer by the hatched ones. The magnitude of the current is indicated by the amount of the circle that is occupied by the section. Where no sectioning appears, it means that there is no current flowing in the conductor.

So far we have considered only loads connected between *A* and *N* or *N* and *B*, that is, across 120 volts. There is, however, no objection to connecting loads directly from *A* to *B*—that is, across 240 volts—as for example the motors *M* shown in Fig. 305. In fact, that is one of the very valuable features of the system. We may use the 240-volt supply for the operation of motors or other large loads, and the 120-volt supplies for the lamps. We thus combine the advantages of a higher voltage for motors with that of a lower one for lamps. The current taken by a load connected to the outside wires has no effect whatever on the current in the neutral. Thus, if all the lamps connected to the system of Fig. 305 were turned off and only the motor load remained on the service, the current in the outside lines *A* and *B* would be that required by the load, while that in the neutral *N* would be zero. This is evident, since there is no connection between the motors and the neutral. Should lights be turned on while the motors are in operation, the currents required by them would divide among the three wires exactly as if there were no motor load, and the motor currents in the outside wires would therefore be increased by the currents required by the lights, while the current in the neutral would be the difference between these lamp currents, which is of course the same as the difference between the outside line currents. Thus, if the motor load *M* were 20 amperes, the lamp load between *A* and *N* (namely, *H*) were 15 amperes and that between *N* and *B* (that is, *K*) were 12 amperes, we would have as the currents in the three lines, $I_A = 20 + 15 = 35$ amperes, $I_B = 20 + 12 = 32$ amperes, and $I_N = 15 - 12 = 3$ amperes; or, if we choose to use the outside line current, $I_N = 35 - 32 = 3$ amperes.

Balancer Sets for Three-wire Systems.—In the foregoing the sources of voltage for three-wire systems have been shown as two generators of about 120 volts each, connected in series, with a tap taken off their common point. This method was the one used in the early days of power distribution, but it has been supplanted by two others, which are the ones in common use to-day. One of them employs what is known as a balancer

set, and the other a special generator known as a three-wire generator.

The balancer set consists of two identical machines, which can operate equally well as motors or as generators, and which are directly coupled together. The simplest arrangement is the one shown in Fig. 312, which represents a 115- to 230-volt system. G is a 230-volt generator, and G_1G_2 are two 115-volt shunt machines that are alike in all particulars. The gener-

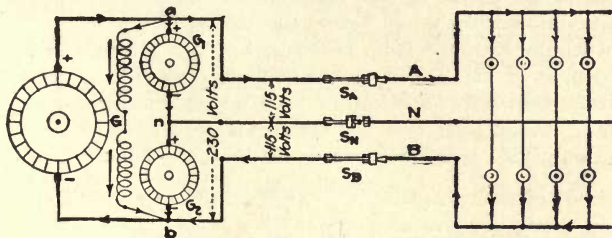

FIG. 312

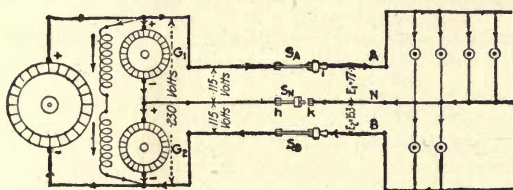

FIG. 313

FIGS. 312 and 313.—Shunt balancer set on three-wire system.

ator G may be far removed from the balancer set G_1G_2 , which may be located near the place where the three-wire service is required. Thus, the 230-volt supply may be received from some outside service, and the balancer set installed to make a three-wire system available from it. From the diagram it is apparent that the balancer set really consists of two 115-volt machines connected in series across 230 volts, with their common point n connected to the neutral N and their other terminals connected to the outside lines A and B .

How Balancer Set Maintains Three-wire Systems Voltage Balanced.—The function of the set is to maintain normal voltage—that is, 115 volts—across each side of the circuit at

all times and thus provide a true three-wire system. The theory of operation will be made clear by comparing the conditions existing in the machines while the load is balanced, with those when it is unbalanced.

Assume that switches S_A and S_B are closed, but S_N left open, as in Fig. 312. If the lamp load is evenly balanced, the voltages from A to N and N to B will have the same value and will be equal to half the voltage across AB ; namely, 115 volts. Under these conditions there will be no difference in voltage across the terminals of switch S_N , and if it were to be closed no current would flow in the neutral N .

Next assume that the lamp load is not evenly balanced while switch S_N is open, as in Fig. 313; then the voltage across AN will be different from that across NB . This can be most readily shown by a numerical example. Thus, if there were one hundred 50-watt 115-volt lamps across AN and only fifty across NB , we would have the following conditions:

The current of each lamp is $I = \frac{W}{E} = \frac{50}{115} = 0.435$ ampere. $R = \frac{E}{I} = \frac{115}{0.435} = 264$ ohms. Since there are 100 lamps in multiple across AN , the resistance connected across these mains would be the resistance of one lamp divided by the 100, or $\frac{264}{100} = 2.64$ ohms, and similarly the resistance across NB would be $\frac{264}{50} = 5.28$ ohms.

We would now have the condition illustrated in Fig. 314, in which R_1 represents the resistance of the lamps between AN and R_2 that of those

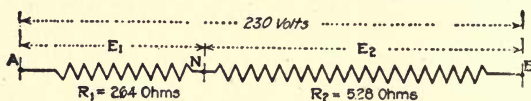

FIG. 314.—Simplified diagram of Fig. 313.

between N and B . The voltage across AB is 230 volts. The question is: What are the voltages E_1 and E_2 across AN and NB respectively? If I is the current flowing through R_1 and R_2 , we will have $E_1 = IR_1$ and $E_2 = IR_2$. To find I we divide the resistance between A and B into the voltage across them, which gives $I = \frac{230}{2.64 + 5.28} = 29$ amperes approximately. We therefore have $E_1 = 29 \times 2.64 = 77$ volts, and $E_2 = 29 \times 5.28 = 153$ volts. The voltage of G_1 is therefore greater than that across AN , whereas the voltage of G_2 is less than that across NB , as shown in the figure. The difference in both cases is the same; that is, $115 - 77 = 38$ volts and $153 - 115 = 38$ volts. This voltage will exist across the two sides

more lightly loaded one. This effect is considerably more accentuated when the connections are those of Fig. 316, since the decrease or increase in voltage across the lines affects the field current. For example, suppose that while no lamps are turned on the voltage of machines G_1 and G_2 have been adjusted by means of their field rheostats R_1 and R_2 until they are both the same, and that more lamps are turned on between A and N than are turned on between N and B . The voltage

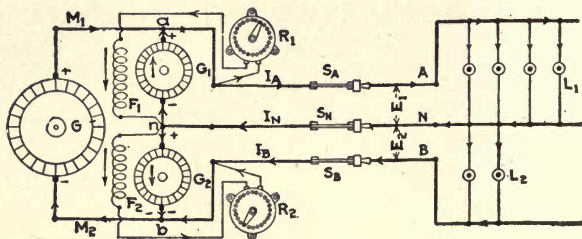

FIG. 316

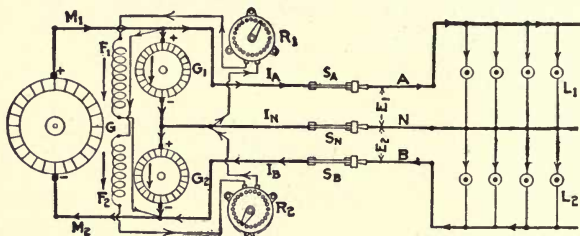

FIG. 317

FIGS. 316 and 317.—Show methods of voltage control of shunt balancer sets on three-wire system.

across AN will thereby be caused to decrease while that across NB increases. That is, the voltage across an decreases and that across nb increases, and consequently the current through the field winding F_1 will be decreased while that through F_2 will be increased. The voltage of G_1 will therefore suffer a still further decrease, just as in the case of any self-excited shunt generator, while the counter-voltage of G_2 , which is running as a motor, is increased.

The difference in voltage between E_1 and E_2 would of course depend on the difference in the loads on the two sides

of the system. It would never be very great even for a considerably unbalanced condition, but a fluctuation of even a few volts is objectionable in the case of a lighting load. A very simple way to overcome the previously mentioned difficulty is to connect the field winding of G_1 to the armature terminals of G_2 , and vice versa as in Fig. 317. In this case a drop in voltage across G_1 will decrease the current through F_2 and consequently reduce the generated voltage, in this case the counter-electromotive force of G_2 , and an increase in voltage across G_1 will have the opposite effect. Similarly, a change in voltage across G_2 will affect the current through F_1 and hence the generated voltage of G_1 .

Compound-wound Balancer Sets.—Another method of stabilizing the voltages across the two sides of the balancer set is to use compound-wound instead of shunt-wound machines. The connections would then be made as shown in Figs. 318 and 319. From the connections in Fig. 318 it is seen that when the load is balanced, the two machines of the balancer set are operating as differentially connected compound motors; that is, the shunt-field ampere-turns oppose those of the series-field winding. When the load is unbalanced, as in Fig. 319, in the machine that acts as a generator (in this case G_1) the currents in the two field windings have the same direction, but the motor fields remained in opposition. The latter condition tends to increase the speed of the motor and with it the speed of the generator, which, if the field strength of the generator remained constant, would cause the voltage to increase across the terminals of G_1 . However, the series-field winding is assisting the shunt field, therefore as the load is increased the voltage of G_1 will also be increased. Hence the voltage of G_1 will be increased from two sources, one the tendency of the machines to increase in speed and also due to the generator field increasing in value from the compounding effect of the series winding. The effect of compounding is therefore similar to that found when the fields of shunt machines are interchanged, in that the unbalancing of the load causes the generated voltage of the generator to increase and

the counter-electromotive force of the motor to decrease, thereby causing the terminal voltages E_1 and E_2 to remain practically constant irrespective of the degree of unbalancing.

Three-wire Generators.—Balancer sets are the most convenient means of providing a three-wire system where a source of voltage for the outside wires is available from a separate service or when the unbalanced current required for the system is small. However, there are conditions where it is pref-

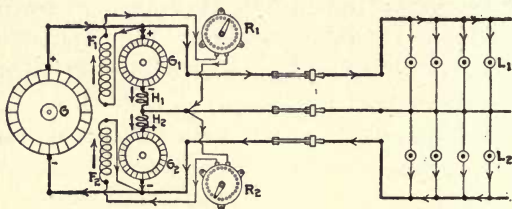

FIG. 318

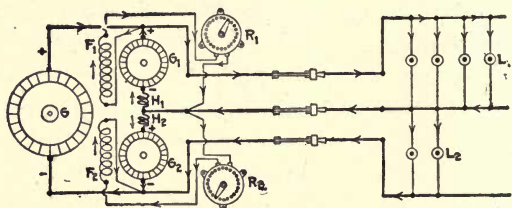

FIG. 319

FIGS. 318 and 319.—Connections for compound balancer set on three-wire system.

erable to use a so-called three-wire generator. This type of machine has come to supplant the combination of two generators in series that was originally used in three-wire installations.

The three-wire generator is an ordinary direct-current generator, excepting that in addition to having a commutator its armature is also provided with slip rings that are connected to the armature winding in the same manner as would be those of an alternating-current generator. The connections between the windings, commutator and the slip rings and the connections of the machine to a three-wire system may be represented

as in Fig. 320. The armature winding is represented by A , the commutator by C , and the slip rings by S . The brushes a b on the commutator are connected to the outside wires A and B of the three-wire system, and the brushes on the slip rings are connected to the ends of two equal inductances L_1 and L_2 connected in series. The mid-point g of these inductances is connected to the neutral N of the three-wire system. With a balanced load on the system only an alternating-current is supplied to the inductances. The value of this current will be small, similar to the current in the primary winding of a transformer at no load. When the load is unbalanced the current flowing in the inductances is a combination of a direct and an alternating one, and its value will therefore be changing from instant to instant. Consequently, we shall have to investigate instantaneous values instead of continuous ones. To study the conditions that exist, refer to Figs. 320 to 323. Assume that the maximum exciting current taken by the inductances L_1 and L_2 is 5 amperes and that the inductances have 100 turns each. Then the maximum ampere-turns (amperes times turns) is $5 \times 200 = 1,000$; that is 1,000 ampere-turns are required to set up, through the core, a magnetic field that will generate a counter-voltage in the coils almost equal to the applied volts across the brushes (220 volts), Fig. 320. There is only about one or two volts difference between the counter-voltage induced in the inductances and the voltage across the direct-current brushes, when the armature is in the position, Fig. 320, and this difference between the applied volts and the counter-volts causes a current to flow that magnetized the core.

If 1,000 ampere-turns are sufficient to set up a magnetic field in the core that will cause to be generated a back pressure in coils L_1 and L_2 almost equal to the applied volts, then if the ampere-turns are increased slightly the counter-pressure will become greater than the applied volts and the inductances L_1 and L_2 will supply power to the system instead of taking power from the armature. This is just what happens in a three-wire generator, as will be shown in the following:

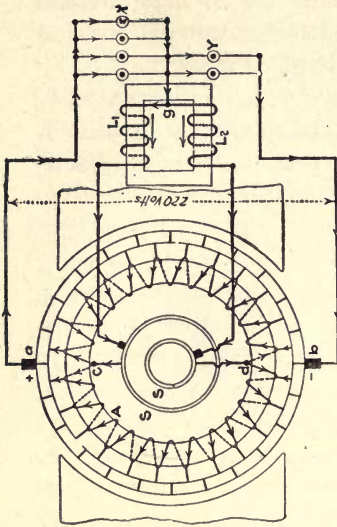

Fig. 321

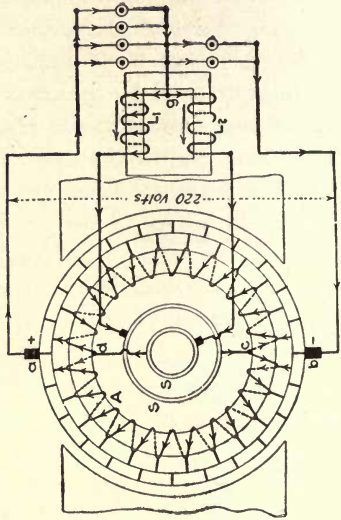

Fig. 323

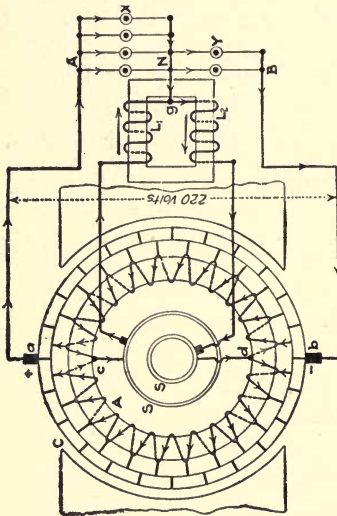

Fig. 320

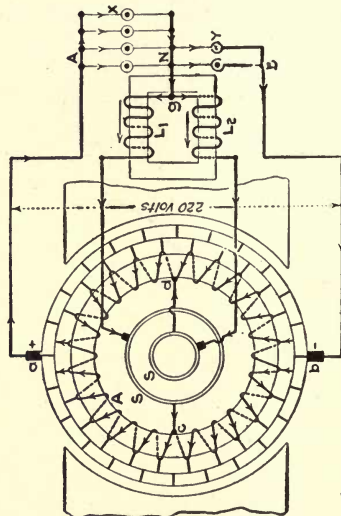

Fig. 322

Figs. 320 to 323.—Diagrams of three-wire generators and circuits.

Assume in Fig. 320 that the load on the system is unbalanced so that 5 amperes is flowing in the neutral. For the position of the armature shown in the figure, up to the point where the unbalanced current is capable of supplying all the ampere-turns, the current in the neutral will flow through L_2 to the negative point in the armature through the armature winding to the positive brush. Now if the 5 amperes flows through L_2 to the negative brush, it will be in the same direction as the magnetizing current flowing from c to d , consequently will increase the ampere-turns by the value of the current in the neutral times the turns in L_2 , or in this case, $5 \times 100 = 500$. The total ampere-turns required are 1,000; then, if 500 ampere-turns are supplied by the current in the neutral, flowing through L_2 , only $1,000 - 500 = 500$ will have to be supplied by the current flowing into c to d through L_1 and L_2 . The magnetizing current will equal the ampere-turns divided by the turns in L_1 and L_2 , or $500 \div 200 = 2.5$ amperes. That is, with 5 amperes flowing in the neutral and through L_2 , only 2.5 amperes will flow from c to d . This will give 2.5 amperes in L_1 and $2.5 + 5 = 7.5$ amperes flowing in L_2 . The ampere-turns supplied by L_1 equal $2.5 \times 100 = 250$ and those in $L_2 = 7.5 \times 100 = 750$ or a total of $250 + 750 = 1,000$, which is correct.

If the current in the neutral was increased to 10 amperes and the total flowed through L_2 , then this inductance would be supplying $10 \times 100 = 1,000$ ampere-turns, or the total magnetizing current. Therefore no current will flow from c to d , but the counter-voltage across L_1 will now be approximately 110 volts, since the magnetic field set up by L_2 also passes through L . The counter-voltage in L_2 is also approximately 110 volts, and this is just as it should be, since at the instant shown in Fig. 320, 220 volts exists between brush a and the negative point d in the armature winding, 110 of which is absorbed in causing the current to flow through the lamps between A and N , and the remaining 110 volts is used up in causing the neutral current to flow through L_2 against its ohmic resistance and counter-voltage. Increasing the load 10 amperes between A and N over that between N and B has caused slight unbalancing of the voltage, so that at the instant in question the voltage across A and B has decreased to a point where it is just equal to the counter-voltage in L_1 ; then an increase in ampere-turns in L_2 , due to a further unbalancing of the load, will cause the back pressure in L_1 to be higher than the voltage between A and N , and L_1 will begin to act as a generator to supply power to the load between A and N .

The foregoing is just the condition that we had with the balancer sets, when the load was unbalanced to the point where the machine running as a motor was supplying all the losses in the set, the voltage of the other machine was just equal to the voltage across the side of the system it was con-

nected to; with any further unbalancing of the load one-half of the current was supplied from the machine operating as a generator and the other half from the main generator. Similarly, with the three-wire generator, Fig. 320, if the load is increased 10 amperes more, making a total of 20 amperes, 5 amperes of this increase will be supplied from the armature and will pass through L_2 from g to d and the other 5 amperes will be supplied by L_1 and will flow from g to c in an opposite direction to the 15 amperes flowing through L_2 as indicated in Fig. 321. Consequently, the $5 \times 100 = 500$ ampere-turns of L_1 is in opposition to the $15 \times 100 = 1,500$ ampere-turns on L_2 , which makes the effective ampere-turns equal to $1,500 - 500 = 1,000$, the same as when 5 amperes flowed from c to d through L_1 and L_2 , or when 10 amperes flowed through L_2 only. Any further unbalancing of the load will continue to divide up equally between L_1 and L_2 and we will have a current flowing in one direction through L_1 and in the opposite direction through L_2 .

Consider the condition that will exist when the armature has made one-quarter revolution, as in Fig. 322. In this position no voltage exists across $c d$. Consequently no magnetizing current will be flowing in L_1 and L_2 , and no counter-voltage will be generated in the windings L_1 and L_2 . However, 110 volts exists from brush a through L_1 to g , also 110 volts from a to g through L_2 ; therefore, the neutral current will divide up equally between the two inductances, 10 amperes flowing through L_1 and 10 through L_2 around through half of the armature winding to brush a . This is just as it should be, since the currents are flowing through the inductances in opposite directions and are equal; the ampere-turns of one are in opposition to those of the other and no flux is caused to flow through the core, consequently no counter-voltage will be induced in L_1 and L_2 .

Consider next the condition when the armature has made one-half revolution, as indicated in Fig. 323. This is identical to what we have in Fig. 321 except that L_1 is now connected to the negative point in the armature and L_2 is connected to the

positive point. Consequently, with the load unbalanced 20 amperes, 15 will flow through L_1 to c and 5 amperes through L_2 to d . Now, it will be seen that the current has increased in L_1 from 5 amperes in Fig. 321 to 15 amperes in Fig. 323, also in L_2 the current has decreased from 15 in Fig. 321 to 5 amperes in Fig. 323. It is this variation in the current that generates the counter-voltage in the inductances as the armature revolves and takes the place of the alternating current that flows in the winding when the load is balanced, or when the machine is running without load.

It must be remembered that although the discussion gives the impression of a considerable lapse of time from one position to another, the transition in reality is very rapid. For example, such an armature might be revolving at a speed of 1500 r.p.m., which is equivalent to 25 revolutions per second, and it would therefore make one revolution in $\frac{1}{25}$ of a second. Since all the changes in current described in the foregoing take place in one-half revolution, they occur in the space of one-fiftieth of a second.

In the explanation of the action of the inductance and how the current divides between them, many other elements that occur to affect the actual conditions have not been considered. This, however, has been done to simplify the reasoning as much as possible.

Power Output of Three-Wire Generator.—Suppose that the load is now unbalanced as in Fig. 324; that is, the load at X is 100 amperes and the load Y 60 amperes, causing a current of 40 amperes to flow in the neutral. It will be noticed that while the current leaving the brush a is 100 amperes, that entering the brush b is only 60 amperes, the difference being accounted for by the 40 amperes that flow from the neutral through the inductances and finally to the armature. The 60 amperes flowing from Y split at the brush b , half passing through each half of the armature winding to the right and left of the brushes a and b , as indicated.

In the foregoing it was shown how, if the exciting current in the inductances was 5 amperes, with the armature in the position in Fig. 324, then when 10 amperes was flowing in the neutral all the excitation for the inductances would be supplied by one inductance; how, when the armature was in the position shown in the figure, L_2 would be supplying

all the ampere-turns, and when the current in the neutral increased above 10 amperes, the increase divided equally between L_1 and L_2 . Therefore, in Fig. 324, 10 amperes of the 40 in the neutral will flow through L_2 to supply the ampere-turns and the remaining 30 will divide 15 through L_1 and 15 through L_2 , making a total of 15 amperes in L_1 and 25 amperes in L_2 . The 25 amperes flowing through L_2 enters the armature winding at d and divides 12.5 amperes flowing through the winding to the right of brushes b and a and 12.5 amperes to the left, making a total of $30 + 12.5 = 42.5$ amperes flowing in each half of the armature, or a total of $42.5 + 52.4 = 85$ amperes. This, added to the 15 amperes delivered by L_1 , makes a total of $85 + 15 = 100$ amperes, leaving the positive brush as indicated.

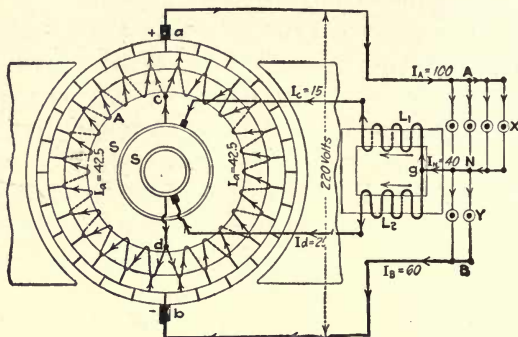

FIG. 324.—Shows distribution of current in three-wire generator.

The next thing is to investigate the power distribution in the system. The entire load on the generator is the sum of the loads X and Y and the excitation required by the inductances L_1 and L_2 .

Since the current in X is 100 amperes and the voltage across it is 110 volts, we have $X = 100 \times 110 = 11,000$ watts. Similarly, $Y = 60 \times 110 = 6,600$ watts, and the watts taken by L_1 and L_2 at the instant shown in the 5×220 or $10 \times 110 = 1,100$, making the total load that the generator has to supply equal to $11,000 + 6,600 + 1,100 = 18,700$ watts. The total current flowing in the armature is $42.5 + 42.5 = 85$ amperes; this value times the voltage gives the load supplied by the armature, equals $85 \times 220 = 18,700$ watts, which checks with the sum of the component loads on the external circuit.

In looking at Fig. 324, at first thought it might appear that the 15 amperes through L_1 should be considered in the current supplied by the armature; the fact is, however, that this current is not supplied from the armature, but is 220-volt power supplied to the system by the armature and is transformed into 110-volt power through the medium of the inductances. This will be more readily understood by referring

to Fig. 325. At the instant shown in Fig. 324, if the inductances were disconnected from the brushes on the slip rings and connected across the line, as in Fig. 325, the conditions would be identically alike except that the current flowing through L_1 would not pass through brush a . The current in the armature (60 amperes from load Y and 25 amperes through load L_2), that is, $I = I_B + I_d = 60 + 25 = 85$ amperes. This gives

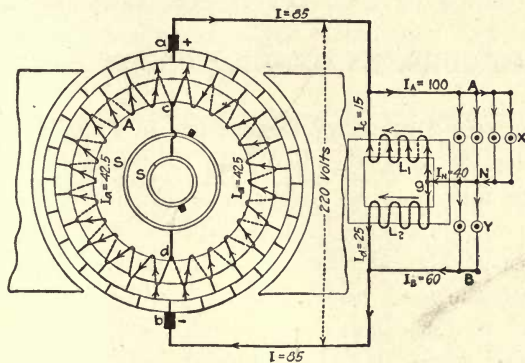

FIG. 325.—Same as Fig. 324, but with the inductance connected to the external circuit.

the total power supplied by the generator equaling $EI = 220 \times 85 = 18,700$ watts, which check up against the lamp load of 17,600 watts, plus the power required by L_1 and L_2 at this instant, to excite them, of 5×220 or $10 \times 110 = 1,100$ watts or a total of $17,600 + 1,100 = 18,700$.

CHAPTER XX

DIRECT-CURRENT GENERATORS IN PARALLEL

Reasons for Operating Generators in Parallel.—When a constant load is to be supplied with electrical power, a single generating unit may be installed to provide the energy, its capacity being just large enough to take care of the load, since it operates at highest efficiency fully loaded. On the other hand, when the load varies greatly from one part of the day to another, it would be uneconomical to supply power from a single unit because it would be operating considerably below full load, and therefore at a low efficiency, for much of the time. Under such circumstances it is usual to provide two or more units of such capacities as will allow of their operation at as nearly full-load conditions as possible at all times.

When two or more generators are furnishing power to a common load, they are said to be operating in parallel. In order that two or more generators operate together satisfactorily each must take its due share of the load. The question is, therefore, Will any two generators operate successfully when connected in multiple? In order to answer this it is necessary to inquire into the factors controlling their behavior. The current delivered by a generator is equal to the difference between the generated and terminal voltages divided by the armature resistance. That is, if I represents the armature current, E_g the generated voltage, E the terminal voltage, and R the armature resistance, we have $I = \frac{E_g - E}{R}$, from which it is seen that E_g and R must bear certain relations to each other. If the machines are of the same size, the relation between the values of these quantities in each

must be such that I is the same in all; if they are of different sizes, the relations must be such that I in each case is proportional to the capacity of the machine.

Effects of Generator Characteristics on Parallel Operation.—The relations existing between current, armature resistance, generated voltage and terminal voltage are governed by the characteristics of the machine. Their effect upon its behavior is most readily determined by reference to the

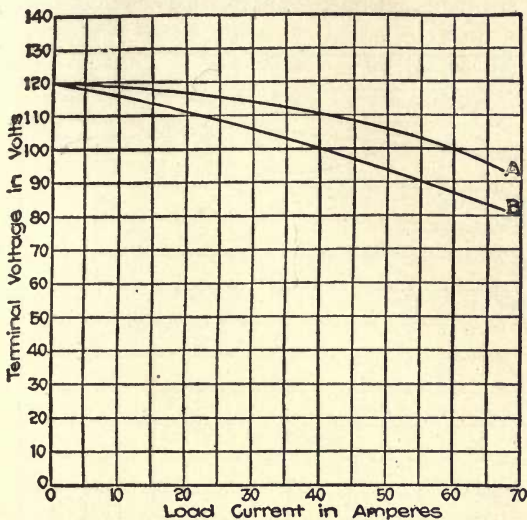

FIG. 326.—External characteristic curves of two shunt generators of unlike design.

external characteristic curve of the machine. This, as will be remembered, is a curve showing the relation between the current delivered by a generator and its corresponding terminal voltage. For a shunt generator its shape would be such as that of the curves shown in Fig. 326, which represent the characteristics of generators of the same size but of different designs. Although having the same voltage at no load—namely, 120 volts—they do not undergo a like decrease in voltage for similar increases in current. For example, at 100 volts the machine of curve A would be taking 60 amperes,

whereas that of curve *B* would be taking only 40 amperes. By increasing the excitation of *B* or decreasing that of *A*, the machines could be adjusted to take the same current at 100 volts, being 60 amperes in the former case and 40 amperes in the latter.

If both machines had precisely the same characteristic, the current in each would be half the total at all times, since at the same terminal voltage the same value of current would be delivered by each. Consequently, it is concluded that gen-

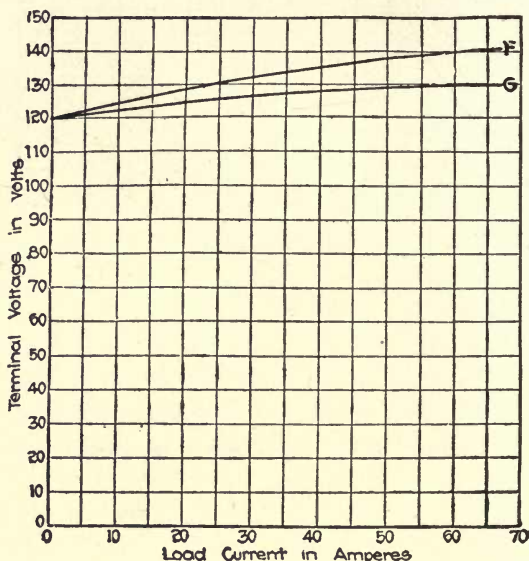

FIG. 327.—External characteristic curves of two compound generators.

erators having unlike external characteristics will not operate in parallel satisfactorily and, conversely, that such as have similar characteristics will do so. If the generators are of different capacities, their characteristics must be such that the total load will always be divided among them in the proportion of their ratings. The same course of reasoning can be applied to any other type of generator, such as the series and compound. Discussion of the former may be omitted, since it finds no practical application, but the latter is of great

importance. The compound generator is the most important of the direct-current machines.

The external characteristics of overcompounded generators have shapes similar to those of the curves illustrated in Fig. 227, in which F is the characteristic of a machine more heavily compounded than the one whose characteristic is G , but of the same capacity. The dissimilarity in the curves will have the same effect as in the case of shunt generators: that is, it will prevent the machines from assuming equal shares of the load. As with shunt generators, they could be made to assume the same terminal voltage for like currents by manipulation of the shunt-field rheostats, but they would not make such a division

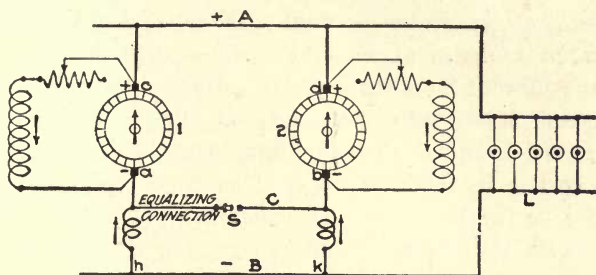

FIG. 328.—Simplified diagram of two compound-wound generators connected in parallel.

of the load of themselves. However, if possessed of identical external characteristics, they will do so, in which respect also they behave as shunt machines would. It would therefore be concluded, as in the case of the shunt type, that machines with unlike characteristics will not operate well in parallel, whereas those of like characteristics will.

The conclusions regarding shunt generators in parallel are borne out in practice, but it is found that compound generators refuse to operate properly even when their characteristics are identical, unless an additional feature, known as the equalizing connection, is provided.

Compound Generators in Parallel.—To facilitate the discussion of the points involved reference will be made to Fig. 328, which shows two compound generators, 1 and 2, connected to the mains A and B , supplying current to a load L .

Suppose A to be the positive and B the negative; then the direction of the currents through the shunt and series fields and in the armatures will be that indicated by the arrowheads. Further suppose that the generators are of the same capacity and design, and that they are overcompounded alike. Also that it has been possible to place them in parallel and that each is therefore delivering half the current supplied to the load L . The following will show that the machines cannot maintain this assumed condition.

Anything affecting the generated voltage of either machine will affect its load current, since $I = \frac{E_g - E}{R}$. For example, the speed of generator 1 might increase slightly, thereby causing an increase of E_g and a consequent increase of I . Since the current flows through the series field of the machine, the increase in its value will cause an increase in the series-field excitation and a corresponding increase in the combined shunt- and series-field strength. The generated voltage will therefore be further increased, causing a yet greater current to flow with the effect of again increasing the field strength and in turn the current. It will be seen that the action is cumulative; that is, that, once started, it will continue unchecked. Just how far it will proceed depends upon the amount of overcompounding. When the current delivered by No. 1 increases, that of No. 2 must decrease, since the load L remains practically unchanged. The effect of a decrease in current of No. 2 is exactly the reverse of what an increase would have as described in the case of No. 1; that is, the initial decrease would cause a diminution of excitation which would further reduce the current delivered, again affecting the field strength. This action will continue until No. 1 carries the entire load and No. 2 carries none. Generally, the action does not cease here, but proceeds until No. 2 is running as a motor driven from No. 1; that is, it takes current from the line instead of delivering its share to it. The direction of the current through its armature would consequently be reversed and therefore that through its series field.

The shunt-field current would, however, continue to flow in the same direction as before, since the field remains connected to the mains as before. The two fields would thus be opposed to each other, with the shunt field predominating at the time the series field begins to reverse. The total field strength will of course be less than that due to the shunt field alone, which will tend to make the machine speed up since it is running as a motor. It is, however, connected to its prime mover whose speed generally cannot be rapidly accelerated, and the motor is therefore compelled to run at the same speed as before even though its field be weaker. The counter-e.m.f. is therefore reduced, which increases the current. This increase in current increases the series-field current, thereby causing a still weaker field and a consequent further increase in current. The action would continue until the current became so great that the safety devices protecting the machine from excessive current would operate.

In practice it is found that the sequence of events enumerated in the foregoing takes place in a very short period of time; in fact, the action gives the impression of being an instantaneous one. No sooner has the incoming machine been connected to the mains than the circuit-breakers open. Often the instantaneous rush of current is so rapid that before the circuit-breakers can interrupt its flow it has become so great that its effect in flowing through the series field is to cause the series-field excitation to exceed that of the shunt field and consequently reverse the direction of the magnetic field. It would then be found that, when the machine was again started, its voltage would build up in the opposite direction to that it previously had. When such a condition exists the polarity can be corrected as indicated in Fig. 329. Here machine *A* is assumed to be the one with reversed polarity. First open the armature circuit by lifting the brushes, or better still by opening the armature and equalizer connections, as in the figure, then close the switch to the bus bars for a short period, which will cause a current to flow through the shunt-field winding in the correct direction to give proper

polarity. In Fig. 329 it will be seen that the current through the shunt-field windings of both machines is the same direction, consequently they will both have the same polarity.

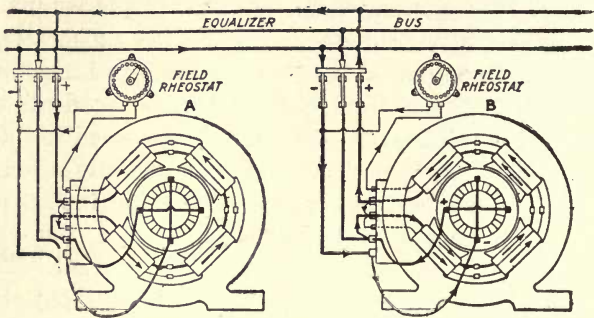

FIG. 329.—Two compound generators connected in parallel.

Equalizer Connection.—As indicated in Fig. 328, the equalizer is a connection between the terminals *ab* of the machines. With switch *s* open they would not operate satisfactorily, but with it closed the equalizing connection would be established and the machines would then operate together successfully. The equalizer connection must always be between the junction points of the armature and series field. That is, it could not be made between *c* and *d*, for example, nor *c* and *b*, nor *a* and *d*. Moreover, it must be of a very low resistance. To more clearly understand the principle involved, reference will be made to Fig. 330, which duplicates the connections of Fig. 328, but shows a slightly different location of the series fields.

If the load is the same on each generator in Fig. 330 and the series-field windings F_1 and F_2 have equal resistance, the current from the negative bus will divide equally through the series windings back to armatures 1 and 2. Assume that one of the machines takes more than its share of the load, say 80 amperes on machine No. 1 and 60 amperes on machine No. 2, or a total of $60+80=140$ amperes. If the series-field windings have equal resistance then the current will continue to divide equally between them, and each will take 70 amperes, but at the equalizer 80 amperes will flow to armature No. 1 and 60 amperes to armature No. 2. This creates a condition where armature No. 1 supplies 80 but only has 70 amperes in its series windings, where No. 2 armature supplies

only 60 amperes, but has 70 amperes through its series winding. On account of the excess current in the series field winding of No. 2 machine the voltage tends to rise and cause the machine to take more load. On machine No. 1 the current in the series winding is less than that required to compensate for the volts drop in the armature, consequently, the voltage of this machine will tend to decrease and give up part of its load to machine No. 2, thus restoring an equal division of load between the two machines. If machine No. 2 takes an excess load the reverse action of that described in the foregoing, takes place and the load is maintained

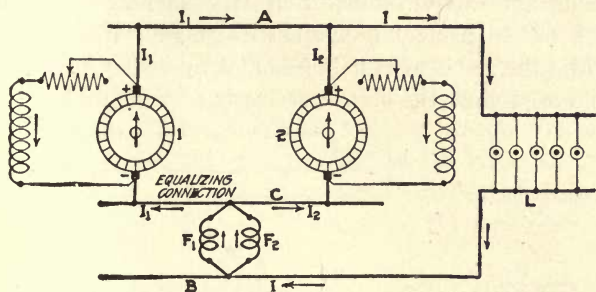

FIG. 330.—Modification of diagram, Fig. 328.

equally between the two machines. Any desired division of the load can be obtained by proper adjustment of the series winding, both as to ampere-turns and resistance. The machine to take the greatest load must have the lowest resistance in its series-field windings.

Since in a shunt generator the voltage falls off as the load increases, two or more machines will operate in parallel satisfactorily. If one machine takes an excess of the load this tends to lower the voltage on this machine, and as the other machine has been relieved of some load its voltage tends to increase. This causes the lightly loaded machine to take more load and restore the balance between the two machines.

Putting Generators into Service.—There are a number of points that require attention when cutting-in a generator to operate in parallel with others and also when cutting-out one that is so operating. In the main the procedure for shunt and compound generators is the same, but there is some difference, and the two will therefore be treated separately.

In Fig. 331 are shown the connections of a self-excited shunt generator G that is part of a system of other generators

connected to the busbars *M*. Within the outline *O* are represented the devices on the switchboard used in controlling it. They consist of the main switch *S*, which is, of course, open when the machine is not in service, the field rheostat *R* for adjusting the current through the field coils *F*, a voltmeter *V*, connected to a switch *T* for obtaining the voltage at the busbars *M* and the generator respectively, an ammeter *A* for measuring the current output of the machine; and circuit-breakers *CC* to protect it against overload. We will assume that while the set is at rest it becomes necessary to place it in service, and follow the steps necessary to accomplish this.

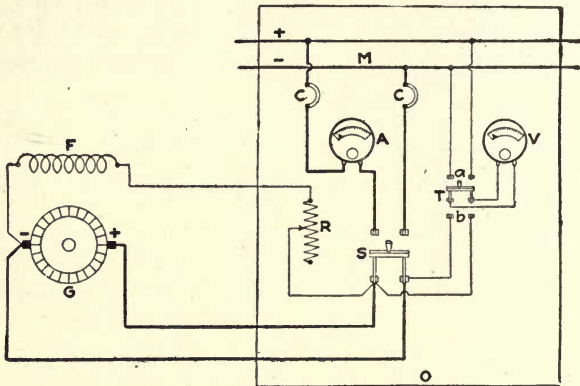

FIG. 331.—Connections for paralleling a shunt generator with one or more machines.

The first thing to do is to start the unit and bring it up to normal speed, after which switch *T* is thrown to position *b* and the field current is adjusted by means of the rheostat *R* until the voltmeter *V* indicates approximately normal voltage. The switch *T* is then thrown to position *a* and the reading of voltmeter *V* is noted, upon which *T* is thrown back to *b* and the voltage of the generator adjusted to exactly the same value by further manipulation of rheostat *R*. Switch *T* is then thrown from *b* to *a* and back again to assure the operator that the two voltages are of like values, and if they are not quite so the rheostat *R* is manipulated until they have been

made equal. The switch S is then closed, thereby connecting the generator to the mains M . If the voltage of the generator has been carefully adjusted to the same value as that of the mains, the ammeter A will indicate no current.

If the voltage of the generator was a little lower than that of the mains, the ammeter will show a reversed deflection, showing that current is being taken from the mains by the machine; and if the generator voltage was somewhat greater than that of the mains, the ammeter would indicate in the correct direction and its reading would be the current delivered to the system by the machine. Having connected the generator to the mains, it is then made to assume its share of the load by adjustment of resistance in the rheostat R . The resistance of the rheostat is reduced until the ammeter A indicates that the generator is delivering the current required of it.

When it is desired to remove a generator from the system, the resistance of the rheostat R is increased until the ammeter A reads approximately zero current, showing that the voltage generated by the machine is exactly equal to the voltage of the mains. The switch S is then opened, disconnecting the generator, whereupon its prime mover is shut down and the unit is dead.

In Fig. 332 are shown the connections for a compound generator corresponding to those for a shunt generator in Fig. 331, except in addition are shown the series-field winding F_s and the equalizing connection B , which is a busbar similar to M_1M_2 . The operation of placing the machine in service, that is paralleling it with another, is identical with that for a shunt generator, except that its voltage is adjusted to be a few volts less than that of the mains instead of equal to it. The reason for this is, that when the switch S is closed current immediately flows through the series-field winding F_s , causing the generator to be supplied with excitation additional to that of the shunt field and consequently inducing a greater generated voltage.

Just how much less than the line voltage the open-circuit

voltage of the incoming generator should be is a matter of trial. Having once been determined, the operator adjusts it to that value whenever cutting-in the machine. A method of

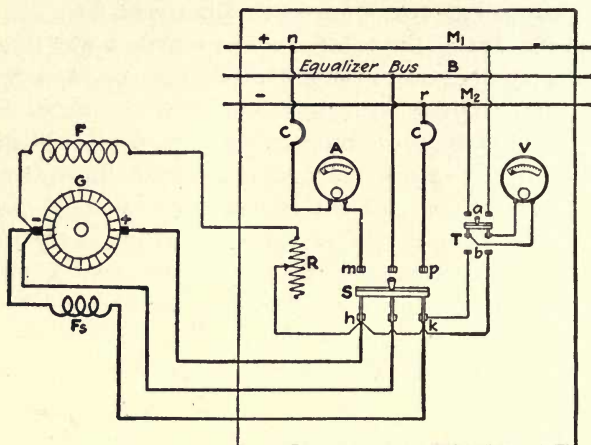

FIG. 332.—Connections for paralleling a compound generator with one or more machines using a three-pole switch.

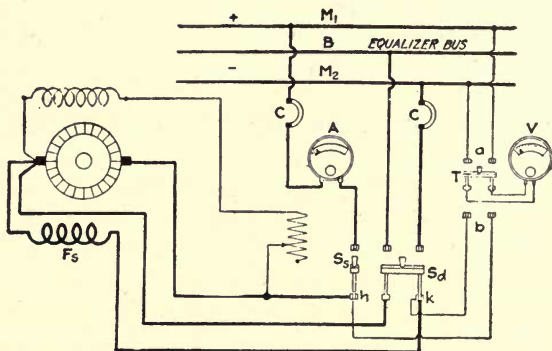

FIG. 333.—Connections for paralleling a compound generator with one or more machines, using a single-pole and a two-pole switch.

avoiding the complications indicated in the foregoing is to substitute a double-pole and a single-pole switch for the three-pole switch S of Fig. 332. Such an arrangement is shown in Fig. 333. In this case the generator is adjusted to approxi-

mately line voltage with the field rheostat and then the double pole switch S_d is closed, thus connecting the series field F_s across M_2 and B , across which are already connected the series fields of all the other generators serving the busbars. Current consequently flows through F_s as explained in the preceding paragraph, thereby increasing the voltage of the generator. This is now adjusted to exactly the same value as the line voltage, as in the case of shunt generators, and the single-pole switch S_s is then closed, thus placing the machine in service.

Having connected a compound generator to the line, the load upon it is adjusted in the same manner as for a shunt generator; namely, by increasing its shunt-field current by cutting resistance out of the shunt-field rheostat. When it is desired to take it out of service, the shunt-field resistance is increased until the excitation has been reduced sufficiently to cause the ammeter A of Fig. 332 to indicate zero current, upon which switch S of Fig. 332 or switches S_s and S_d of Fig. 333, as the case may be, are opened and the set shut down.

Parallel Operation of Three-wire Generators.—In the case of a compound three-wire generator there is one complication to which attention must be drawn. When the system is balanced there will be no current in the neutral N , Fig. 334, and

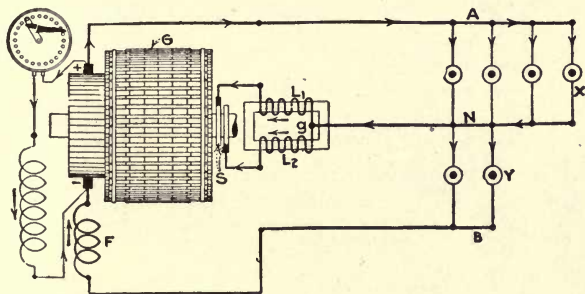

FIG. 334.—Three-wire compound generator; series-field winding in one section.

the current in B will be the same as that through A , and the conditions will be the same as in a two-wire system. Assume that the load is unbalanced; for example, that more lamps are

turned on at X than at Y . There will then be less current in B than in A , and consequently less current through the series field F than is delivered by the armature G . The extreme case would be all the lamps at X turned on and all at Y turned off. There would then be no current through B and therefore none through F . That is, although the generator would be delivering half its rated output, there would be no current through its series field and consequently no series-field magnetic flux to keep the voltage from dropping with increase of load.

On the other hand, if all the lamps at Y were to be turned on and those at X turned off, there would be no current in A , and B would carry full-load current, causing full-load current to flow through F . The series-field excitation would therefore be the same as it would be if all the lamps in both X and Y were turned on, and it would give as much compounding in the one case as in the other.

To overcome these disadvantages it is necessary to connect one half of the series-field winding into one side of the circuit and the other half into the other side, as F_1 and F_2 in Fig. 335. This offers no difficulty, since there are always at least

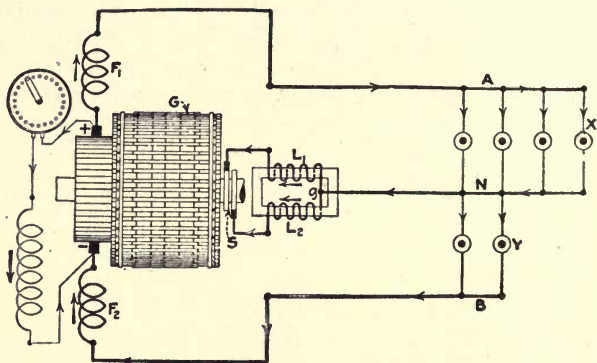

FIG. 335.—Three-wire compound generator; series-field winding divided into two sections.

two poles, and since each pole has its share of the series-field winding wound upon it. With this arrangement the currents in A and B each produce the correct amount of magnetization.

If the machine is a multipolar one it would be necessary

to connect alternate series-field windings in series somewhat as shown in Fig. 336, which represents the connections for the series-field windings of a six-pole compound-wound three-wire generator. (The shunt-field windings are not shown.) The discussion in reference to series windings applies equally to those on interpoles. That is, when a three-wire generator is of the interpole type, half the interpole windings must be connected into one side of the system and half into the other,

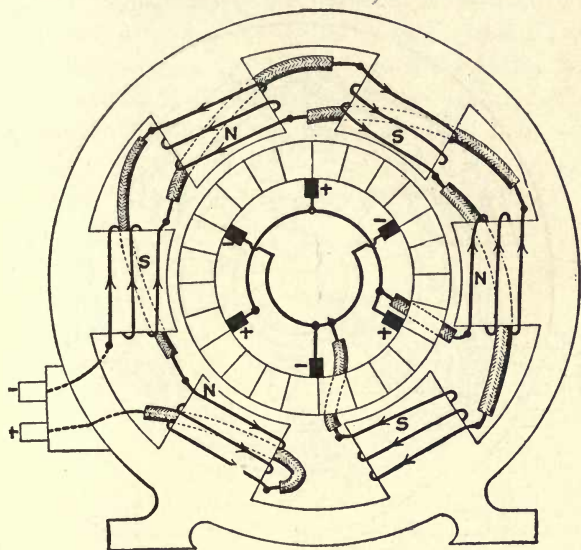

FIG. 336.—Series winding on three-wire generator.

otherwise there would be times when too little current would flow through them and others when there would be too much. The distribution of the windings can be accomplished in the same manner as with the series windings; namely, by connecting alternate ones in series and then connecting one group to the positive armature terminal and the other to the negative one.

If the machine is a compound one, each group of interpole windings would of course be connected in series with one group of series-field windings. In connecting up the series and interpole windings of such machines, great care must be

exercised to make the connections in such manner that the magnetic poles created by the current through them shall have the correct polarity. If the poles created by the shunt-field winding are those indicated by *N* and *S* in Fig. 336, the connections for an interpole machine would have to be those of Fig. 337 if the direction of rotation is that indicated by the arrow *K*. If the direction of rotation were the reverse the connections would have to be changed to give correct polarity.

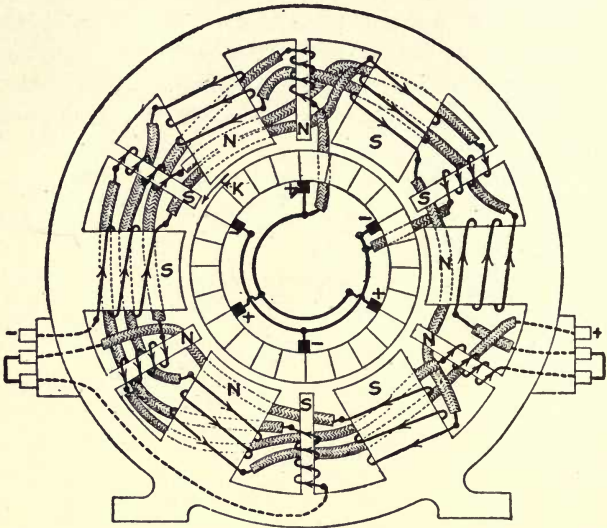

FIG. 337.—Series and interpole winding on three-wire generator.

When dealing with three-wire systems of large demand or having heavy peak loads at certain hours of the day, the same factors govern as in any other electrical system, and it may become necessary or advisable to install several units to supply the load instead of a single one. When such is the case, three-wire generators are operated in parallel.

A diagrammatic representation of two compound-wound three-wire generators connected in parallel is given in Fig. 338. As explained in the foregoing, the series-field windings of compound three-wire generators must be divided into two parts, one of which is inserted between one terminal of the

armature and a main and the other between the other terminal and main, as at F_a , F_b , F_c and F_d . With compound generators in parallel it was shown that it is necessary to have an equalizing connection joining those terminals of the armatures to which the series-field windings are connected. In the case of the three-wire generator it is therefore necessary to provide two equalizing connections, since both the armature terminals in this case have series-field connections made to them. These two equalizers are shown at Z_1 and Z_2 , and connect a to c and b to d . The series fields F_a and F_c are connected between Z_1 and the main A , and the series fields F_b and F_d are connected between Z_2 and the main B . The mid-points g_1 and g_2 of the inductances $L_a L_b$ and $L_c L_d$, are connected to the neutral main N .

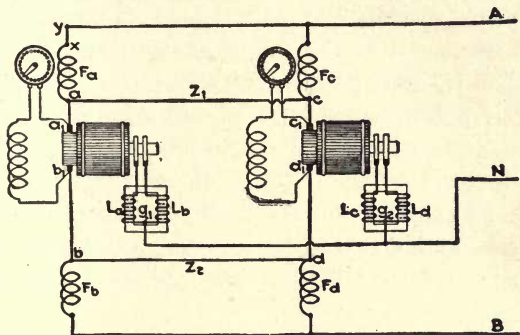

FIG. 338.—Schematic diagram of two three-wire generators connected in parallel.

The two equalizers function in exactly the same manner as does the single equalizer used when two-wire compound generators are operated in multiple. Thus, Z_1 connects F_a and F_c in multiple and thereby causes whatever current flows in A to split evenly between them. Likewise Z_2 connects F_b and F_d in multiple and causes the current in B to divide equally between them. In order that such shall be the case, it is of course necessary that the resistance of F_a equal that of F_c and the resistance of F_b shall equal F_d , as was explained at the time that compound generators were discussed. Although only two generators are shown in the diagram, it

is to be understood that any number of machines may be connected in parallel in the same manner.

The method of operating three-wire compound generators in multiple is essentially the same as that outlined for ordinary two-wire machines. The chief points of difference are that with the three-wire generator we have the inductances to connect to the alternating-current side of the machine and that we must make provision for connecting the mid-point of the inductances to the neutral main at the same time that connection is made between the direct-current side of the machine and the outside mains.

It is also necessary to provide two ammeters for each machine since the current in the two outside mains is not the same when there is current flowing through the neutral. It is also desirable to have a third ammeter to measure the current in the neutral. If one is installed, it should be of the type that has its zero point at the middle of the scale and reads in both directions from the center, since the direction of the current in the neutral may be in either direction, depending upon which side of the system is the more heavily or lightly loaded. The ammeters that are used to measure the currents in the outside mains should be connected between the series field and the armature. Thus, in Fig. 338 the ammeter should be connected between a and a_1 , b and b_1 , etc. They will then measure the current actually delivered by the armature.

If the ammeter were to be connected between the series fields and the mains, as for example, between x and y , the current measured would be that through the series field. Since the currents through all the fields between A and Z_1 or between B and Z_2 are the same, the reading of the ammeter would be no indication of the load carried by the machine. This condition also introduces a complication when interpoles are used on compound generators. Since the current through the interpole windings must change with the armature current in order to secure good commutation, it follows that the interpole windings must be connected into the same part of the circuit as are the ammeters.

CHAPTER XXI

FUNDAMENTAL PRINCIPLES OF ALTERNATING CURRENT

Dynamo-electric Machines Fundamentally Generate Alternating Current.—Before taking up the studies of alternating current the student should get firmly in mind the principles laid down in Chapter X. In this chapter it is shown that all dynamo-electric machines are fundamentally alternating-current machines, and may be converted into direct-current generators by the use of a commutator. Figs. 146 to 149 in Chapter X explains how a coil with its ends connected to two rings will deliver an alternating current to an external circuit. This current, it is explained, may be represented by a curve, Fig. 152.

For a thorough understanding of alternating current one must first get a clear conception of the underlying principles, which will here be taken up briefly.

An angle may be considered as generated by the radius of a circle revolving about a point at the center of the circle; thus, in Fig. 339, if the radius OB be revolved counter-clockwise about the point O from the horizontal position OA to the position OB , angle BOA will be generated, and if a perpendicular is let fall from B to the opposite side OA , the right triangle OBD will be formed. In any right triangle the sine of either acute angle is the ratio of the opposite side to the hypotenuse; thus, in Fig. 339, the sine of the angle ϕ equals $\frac{BD}{OB}$, or the sine of angle

$\phi = \frac{OD}{OB}$. If side OB is given a value of unity, sine ϕ will equal $\frac{BD}{1} = BD$.

When OB coincides with OA , angle ϕ will equal zero and BD will also equal zero; therefore the sine of angle ϕ will be $\frac{0}{OB} = 0$. When OB has revolved up into the vertical position OE , BD will be equal to and

coincide with OB ; therefore, sine 90 deg. will be $\frac{OB}{BD} = \frac{1}{1} = 1$. Thus it is seen that the sines of angles between zero and 90 deg. vary from zero to unity; these values are given in Table II.

The cosine of an angle is the ratio of the adjacent side to the hypotenuse; thus the cosine of an angle $\phi = \frac{OD}{OB}$. When angle ϕ is zero, OB coincides

with and is equal to the side OD ; therefore, cosine ϕ deg. $= \frac{OD}{OB} = \frac{1}{1} = 1$.

As OB revolves around to the vertical position OE , OD decreases in length until, when OB coincides with OE forming an angle of 90 deg. with OA , OD becomes zero; therefore, cosine 90 deg. $= \frac{OD}{OB} = \frac{0}{1} = 0$. From this

it will be seen that the cosine of the angle decreases from unity for an angle of 0 deg. to zero for 90 deg., which is just opposite to the sine. The values given in Table II, for the sines and cosines are the natural functions and should not be confused with the logarithmic values.

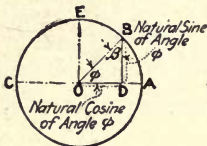

FIG. 339

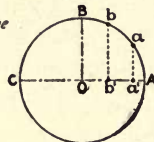

FIG. 340

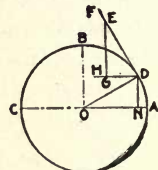

FIG. 341

FIGS. 339 to 341.—Illustrating harmonic motion.

Distance Traveled and Rate of Motion.—One must be careful to distinguish between the distance through which a body moves and its rate of motion. A train going from New York to Philadelphia travels approximately 90 miles, and if the run is made in 120 minutes, the average rate of motion would be $\frac{3}{4}$ mile per minute. In this case 90 miles is the distance traveled and $\frac{3}{4}$ mile per minute the average rate of motion. If for each minute that the train is in motion it travels $\frac{3}{4}$ mile, it will be traveling at a uniform rate and may be said to have uniform motion; that is, it will move through equal units of space in equal units of time. For this to be possible the train would have to be moving at $\frac{3}{4}$ mile per minute at the beginning and at the end of the run. If it were to start from rest and travel the 90 miles and come to rest again in 120 minutes, although the average rate of motion

would be $\frac{3}{4}$ mile per minute, the train would have a varying motion, for it cannot start and stop instantaneously, but must start from rest and gradually increase to full speed, which must be greater than $\frac{3}{4}$ mile per minute to make up for lost time at starting and stopping and gradually coming to rest at the end of the run. The rate of increase in motion is called acceleration, whereas the rate of decrease is called deceleration, or retardation. There are several kinds of varying motion, but the one that is most important in the study of alternating current is harmonic motion.

In Fig. 340 suppose a body to be moving around the semicircle ABC at a uniform rate and also a second body moving across the diameter AC at such a rate that it will always remain in the same vertical plane as the body moving around the path ABC ; that is, when the body moving around the semicircle is at a the body moving along the diameter will be at a' , as indicated, or when the first body is at b the second will be at b' , etc. From this it will be seen that although the body moving around the semicircle has a uniform motion, that moving across the diameter has a varying motion starting from rest at A , reaching a maximum at O , and then decreasing in speed until it comes to rest again at C . This body is said to have harmonic motion and will be referred to later.

When the two bodies are in the vertical plane BO , Fig. 340, they are both moving in the same direction and at the same rate. If the radius of the circle ABC in Fig. 341 is let to represent the maximum rate of motion of the body moving along the diameter AC and consequently the rate of motion of the body moving around the semicircle ABC , the rate of motion of the former at any point along the diameter is equal to the perpendicular distance (such as DN) between the two bodies at any instant. It will be observed that DN increases in value from zero at A until it is equal to the radius BO at B . Following is a proof of this rule:

The direction of motion at any instant of a body moving in a circle is always tangent to the circumference, or at right angles to the radius. In Fig. 341 consider the instant when

the body is at D , at which time it will be moving at right angles to the radius DO . Draw the line DF at right angles to DO ; then DF represents the direction of motion at this instant. On DF lay off the distance DE equal to the radius DO (equal to the rate of motion of the body moving around the circle). Draw DH parallel to the diameter AC and from E let fall a perpendicular to DH , thus forming the right triangle DEG . Now if DE equals the rate of motion of the body around the circle, DG will equal the rate of motion at this instant of the body moving along the diameter AC . The right triangles DEG and DON are similar (their corresponding sides being perpendicular); therefore $DE : OD = GD : DN$. But as DE was made equal to OD , it follows that GD must equal DN . Since DG equals the rate of motion of the body moving along the diameter, DN , the perpendicular distance between the two bodies at any instant will also equal the rate of motion of the body along the diameter.

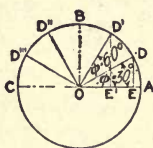

FIG. 342

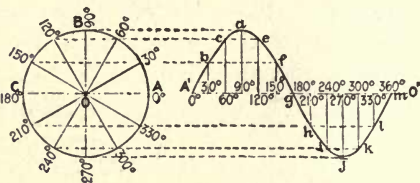

FIG. 343

FIGS. 342 and 343.—Relation between constant and harmonic motion.

To illustrate, assume in Fig. 342 that the body traveling around the semicircle ABC is moving at the rate of 15 ft. per sec., which is also the maximum rate along the diameter AC . Let the radius OA represent this rate, and consider the instant when the body has moved through 30 deg. on the semicircle, as shown by the position D . The perpendicular DE will represent the rate along the diameter AC at this instant. By joining O and D the triangle ODE will be formed. Then $\sin 30 \text{ deg.} = \frac{DE}{OD}$, whence $DE = OD \sin 30 \text{ deg.}$ In this case $OD = 15$ ft. per sec. and $\sin 30 \text{ deg.} = 0.5$ (see Table II). Therefore, $DE = 15 \times 0.5 = 7.5$ ft. per sec., which is the rate at which the body along the diameter is moving at this instant. This must not be confused with the distance traveled, as the body has moved only the distance AE , which in this case is about 2.1 ft., but in moving this distance the body has been accelerated to about

7.5 ft. per sec. At 60 deg. $D'E' = OD' \sin 60 \text{ deg.} = 15 \times 0.866 = 12.99 \text{ ft.}$ per sec., and the body has moved the distance AE' or 7.5 ft. In each case the rate of the body moving along the diameter AC is proportional to the sine of the angle through which the body traveling around the circle has moved. On the line $A'O'$, Fig. 343, lay off distances proportional to the divisions of the circumference of the circle ABC in Fig. 342, and project horizontally the various points on the circle to meet the vertical ordinates erected at corresponding points on the line $A'O'$, thus locating points A', b, c , etc., respectively. By joining these points a curve will be formed as shown. The vertical distance from any point in this curve to the base line AO will be proportional to the sine of the corresponding angle in the circle ABC . For this reason the curve thus formed is called a sine curve. This is the curve of electromotive force generated by a conductor revolving about an axis at a constant speed in a uniform magnetic field, as will be shown later.

Principles of the Dynamo-electric Machine.—When a conductor is moved in a magnetic field so as to cut the lines of force there is always a difference of potential developed between its terminals, or in other words an electromotive force is induced in the conductor. This is the fundamental principle of all direct- and alternating-current generators. The direction of the electromotive force depends upon the direction of motion of the conductor and the direction of the lines of force in the magnetic field. The magnetude of the e.m.f. is directly proportional to the number of lines of force cut per unit of time; this for a given uniform magnetic field depends upon the rate at which the conductor is moving and the angle it is moving through, with reference to the lines of force. In Fig. 344 let the line ab represent the direction and rate of motion of the conductor, when it is moving at right angles to the lines of force (across the magnetic field). When moving at a different angle, such as that shown at $a'b'$, the conductor will not cut so many lines of force in a given time, although it moves at the same rate. Here it has moved only a distance at right angles to the lines of force equal to the projection of the line $a'b'$ on the horizontal as indicated by the line cb' , which represents the rate at which the lines of force are cut for this direction of motion through the magnetic field. When the conductor is moving parallel with the lines of force as

represented by $a''b''$, it is not cutting any lines of force; consequently it is generating no e.m.f. From this it is obvious that the e.m.f. generated by a conductor moving at a constant rate in a uniform magnetic field depends upon the angle at which the conductor is moving with reference to the lines of force—varying from zero when the conductor is moving parallel with the lines of force to a maximum when it is moving at right angles to them.

Alternating Electromotive Force.—When a conductor is revolved about an axis at a constant rate in a uniform magnetic field, its rate of motion is the same with reference to the

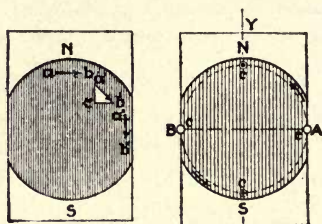

FIG. 344

FIG. 345

FIGS. 344 and 345.—Shows how voltage is proportional to number of lines of force cut in unit time.

neutral axis of the magnetic field as that of the body moving across the diameter AC in Fig. 340. In Fig. 345 the conductor c starts from the position A and revolves around in the dotted circle at a constant rate in the uniform magnetic field between the north and south poles. When it is in the neutral axis AB it is moving parallel with the lines of force; consequently, its motion with reference to the horizontal axis of the magnetic field is zero; but as it moves around in its path, its motion across the horizontal axis increases until it is in the vertical axis XY , at which point it is moving parallel to the horizontal axis, and at right angles to the lines of force and is consequently generating the maximum e.m.f. Beyond this point the e.m.f. decreases until it again becomes zero when the neutral axis is reached at B . On the other half of the revolution the e.m.f. generated in the conductor will pass through

the same series of values as on the first half, but in the opposite direction, for the conductor is moving across the magnetic field in the opposite direction. From the foregoing it will be seen that the motion of the conductor across the horizontal axis in Fig. 345 is the same as the motion of the body across the diameter of the semicircle in Fig. 340, or in other

TABLE II—NATURAL SINES AND COSINES

Ang.	Sine	Cosine	Ang.	Sine	Cosine	Ang.	Sine	Cosine
0	0.0000	1.0000	31	0.5150	0.8572	62	0.8803	0.4695
1	0.0174	0.9998	32	0.5299	0.8481	63	0.8910	0.4540
2	0.0349	0.9994	33	0.5446	0.8387	64	0.8988	0.4384
3	0.0523	0.9986	34	0.5592	0.8290	65	0.9063	0.4226
4	0.0698	0.9976	35	0.5736	0.8192	66	0.9136	0.4067
5	0.0872	0.9962	36	0.5878	0.8090	67	0.9205	0.3907
6	0.1045	0.9945	37	0.6018	0.7986	68	0.9272	0.3746
7	0.1219	0.9926	38	0.6157	0.7880	69	0.9336	0.3584
8	0.1391	0.9903	39	0.6293	0.7771	70	0.9397	0.3420
9	0.1564	0.9877	40	0.6428	0.7660	71	0.9455	0.3256
10	0.1737	0.9848	41	0.6561	0.7547	72	0.9511	0.3090
11	0.1908	0.9816	42	0.6691	0.7431	73	0.9563	0.2924
12	0.2079	0.9782	43	0.6820	0.7314	74	0.9613	0.2756
13	0.2250	0.9744	44	0.6947	0.7193	75	0.9659	0.2588
14	0.2419	0.9703	45	0.7071	0.7071	76	0.9703	0.2419
15	0.2588	0.9659	46	0.7193	0.6947	77	0.9744	0.2250
16	0.2756	0.9613	47	0.7314	0.6820	78	0.9782	0.2079
17	0.2924	0.9563	48	0.7431	0.6691	79	0.9816	0.1908
18	0.3090	0.9511	49	0.7547	0.6561	80	0.9848	0.1737
19	0.3256	0.9456	50	0.7660	0.6428	81	0.9877	0.1564
20	0.3420	0.9397	51	0.7771	0.6293	82	0.9903	0.1392
21	0.3584	0.9336	52	0.7880	0.6157	83	0.9926	0.1219
22	0.3746	0.9272	53	0.7986	0.6018	84	0.9945	0.1045
23	0.3907	0.9205	54	0.8090	0.5878	85	0.9962	0.0872
24	0.4067	0.9136	55	0.8192	0.5736	86	0.9976	0.0698
25	0.4226	0.9063	56	0.8290	0.5592	87	0.9986	0.0523
26	0.4384	0.8988	57	0.8387	0.5446	88	0.9994	0.0349
27	0.4540	0.8910	58	0.8481	0.5299	89	0.9998	0.0174
28	0.4695	0.8830	59	0.8572	0.5150	90	1.0000	0.0000
29	0.4848	0.8746	60	0.8660	0.5000			
30	0.5000	0.8660	61	0.8746	0.4848			

words, the conductor has harmonic motion across the magnetic field. Since the e.m.f. is directly proportional to the motion of the conductor across the magnetic field at any instant the electromotive forces generated at the different instances are sometimes spoken of as harmonic electromotive forces.

It was shown in Fig. 341 that, where the radius equaled the maximum rate, the rate of the body moving along the diameter at any instant is equal to the vertical distance between the two bodies for a corresponding period and proportional to the sine of the angle between the two bodies. If the radius about which the conductor is revolving in Fig. 345 is let equal the maximum rate at which the lines of force are cut, and therefore the maximum e.m.f., the vertical distance between the conductors and the horizontal axis at any instant will equal the rate at which the lines of force are cut, or value of the e.m.f. generated for a corresponding position.

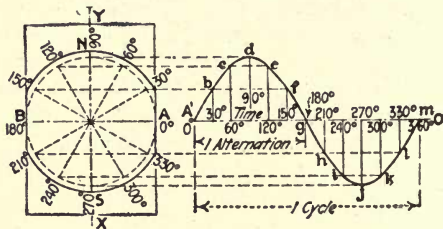

FIG. 346.—Shows how sine curve is developed.

In Fig. 346 if several positions are taken as shown, to indicate the location of the conductor at different points in its revolution a curve may be constructed as was done in Fig. 343. In this case, however, the vertical distance between the curve and the base line will represent the value of the e.m.f. generated by the conductor for a corresponding instant. The sine curve generated by a conductor revolving about an axis at a constant speed in a uniform magnetic field is the ideal pressure curve from an alternator and represents quite closely the e.m.f. and current waves generated by a large class of alternating-current generators.

Electrical Degrees.—The line *AO*, Fig. 347, is used to denote time, the period of time being expressed in degrees, minutes and seconds. It may at first be difficult to understand how time can be expressed in degrees, minutes and seconds instead of hours, minutes and seconds; but this is easily explained when it is considered that our 24-hr. day is the time required for the earth to complete one revolution (360 deg.) on its axis. When it has revolved through 15 deg., then $\frac{15}{360}$, or $\frac{1}{24}$ of a day (1 hr.), has passed. If the time required by the earth to make a revolution or part of a revolution can be expressed in degrees, it follows that the time required by any device to perform its cycle of operation may be expressed in degrees, minutes and seconds.

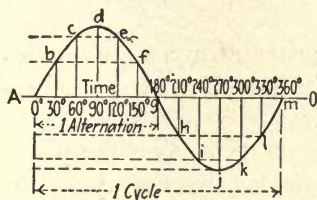

FIG. 347

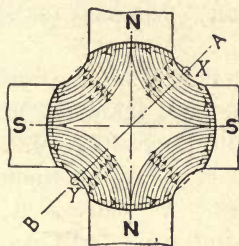

FIG. 348

FIG. 347.—Represents an alternating current or voltage cycle.

FIG. 348.—Represents the magnetic field of four-pole machine.

One should be careful not to confuse this with geographical or space degrees, although they are the same for a two-pole machine. In a four-pole machine the conductor would make only one-half revolution, that is, revolve through 180 space degrees to pass by a north and one of its adjacent south poles, as shown in Fig. 348, where the conductor starts from the position *X* on the axis *AB* and revolves to the position *Y*. In doing so it has generated a cycle, as in Fig. 346; but in this case the conductor has passed through only 180 space degrees, although it has generated a complete cycle of 360 electrical or time degrees. On the other half of the revolution another cycle is generated, the curve in Fig. 349 indicating the complete series of values the e.m.f. passes through on a four-pole

machine, which shows that the conductor in making one revolution (360 space degrees) generated 720 electrical or time degrees. In a six-pole machine the conductor would pass through 120 space degrees, or one-third of a revolution, in generating 360 electrical or time degrees; in an eight-pole machine, 90 deg. etc.

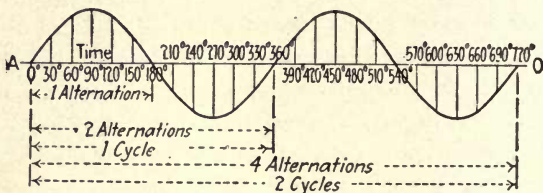

FIG. 349.—Represents two cycles of alternating current or voltage.

The flow of an alternating current in a circuit is explained in Figs. 350, 351 and 352. Beginning at *A* on the time line, Fig. 350, the voltage starts from zero and increases in value until it reaches a maximum at 90 deg. Assume this gives the alternator a polarity as indicated in Fig. 351; then the increasing e.m.f. will set up an increasing current in the circuit of a direction as indicated by the arrowheads, and its value may be represented by the dotted curve, Fig. 350. Beyond the 90-deg. point the voltage decreases, becoming zero at the 180-deg. point; likewise, the current. At this point the conductor passes under poles of opposite polarity and the e.m.f. is reversed. This will change the polarity of the machine as in Fig. 352, and again the e.m.f. and the current pass through a series of values from zero to maximum and from maximum to zero, in the opposite direction. From this it is seen that the current and voltage are continually surging back and forth in the circuit; a wave in one direction being called an alternation, and a wave in one direction and then in the opposite direction, a cycle, or period, as shown in Fig. 347. An alternating current may be likened to the ebb and flow of the tide, the ebb being one alternation, the flow tide another alternation, the two combined forming a cycle.

Another analogy is shown in Fig. 353. Suppose the piston to start from rest at the position shown and gradually increase in motion and come to rest at the other end of the cylinder. This would cause the fluid to flow through the pipe from *B* to *A*. If the piston reverses and returns to its original position, the fluid would flow in the opposite direction. Thus the fluid has completed a cycle, and if the piston is kept moving back and forth the water will be kept flowing back and forth in the system. This is the way a current of electricity flows back and forth in an alternating-current circuit.

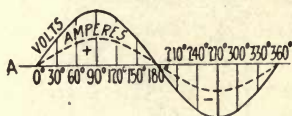

FIG. 350

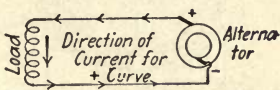

FIG. 351

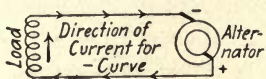

FIG. 352

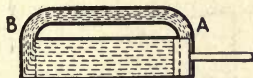

FIG. 353

Figs. 350 to 353.—Represent the flow of alternating current.

A Number of Conductors Connected in Series Generating Voltage.

What has been shown of the action of one conductor moving around in a magnetic field is also true of a number of conductors connected in series, as in Figs. 354 to 357. Here, for purposes of illustration, a ring armature is shown with several coils in series connected to two collector rings, *r* and *r'*, the arrowheads indicating the direction of the e.m.f. induced in the armature conductors for the direction of rotation and the polarity shown. When in the position indicated in Fig. 354, the voltage between the collector rings will be zero, as the e.m.f. generated in the section *ab* opposes that in section *ad*, likewise, the e.m.f. in section *bc* opposes that in section *cd*. Consequently the e.m.f. between points *b* and *c* will be zero, and these are the points to which the collector rings are connected.

When the armature has moved around to the position shown in Fig. 355, the electromotive forces generated in the conductors are in the same direction on either side of the points where the rings connect to the winding; that is, the

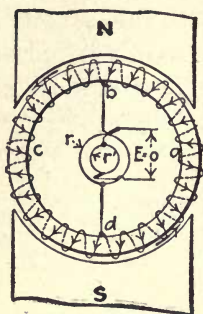

FIG. 354

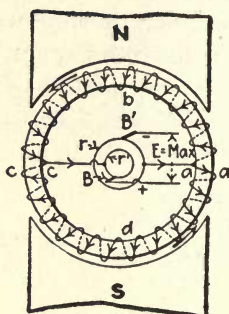

FIG. 355

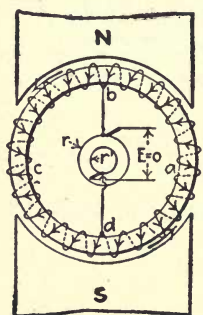

FIG. 356

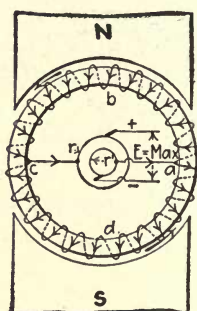

FIG. 357

FIGS. 354 to 357.—Diagrams of a single-phase alternator.

voltages generated in each conductor on either side of points a and c are in the same direction, and they combine to produce a maximum e.m.f. of a direction as shown. When the armature is in the position of Fig. 356, the e.m.f. will again be zero for the reason described in connection with Fig. 354. Hence, the e.m.f. at the collector rings starts from zero for the position shown in Fig. 354, increases to a maximum at the position in Fig. 355, then decreases to zero for Fig. 356; beyond which it increases until the armature is in the position

of Fig. 357, where the voltage between the collector rings is again at a maximum, but in the opposite direction to that in Fig. 355, as indicated. When the armature completes the other quarter of its revolution, it will again be in the position shown in Fig. 354, and the voltage will be zero; consequently the e.m.f. has passed through the same series of values on the last half of the revolution as it did on the first half but in the opposite direction, just as that generated by the conductor in Fig. 346.

Most modern alternating-current machines above 37.5 kw. are constructed with the armature winding stationary and the field structure revolving and are known as revolving-field alternators.

At first thought it may seem that, since the voltage of the direct-current machine is constant and that of the alternating-current machine constantly changing, there must be some radical difference in the construction of the two machines. However, the only essential difference is that the direct-current machine requires a commutator, for changing the alternating e.m.f. generated in the armature coils into a direct e.m.f. at the brushes. The relation between a direct voltage and an alternating one will be understood by referring to Figs. 360 to 361, which show the same combination of coils and polepieces as in Figs. 354 to 357, except in the latter case the coils connect to a segmental commutator instead of two continuous rings.

The brushes B and B' , Fig. 360, rest on segments a and e , which connect to the points of maximum e.m.f., giving the external circuit the polarity indicated. As the armature continues to revolve, segments a and e move out from under the brushes and segments b and f move in, as in Fig. 359. This still leaves the brushes in contact with segments on the same axis as in the first case, which is also true in Fig. 360. From this it will be seen that the brushes are always in contact with a position in the armature coils of maximum voltage and constant polarity, which will deliver a continuous current in the external circuit, or, as it is usually called, a direct current.

It will be observed from the foregoing that the voltage of a direct-current machine having the same winding as a single-phase alternating-current machine will generate a constant voltage equal to the maximum e.m.f. of the alternating-current machine. This is indicated in Fig. 361, the curve representing the alternating voltage, whereas the vertical distance between

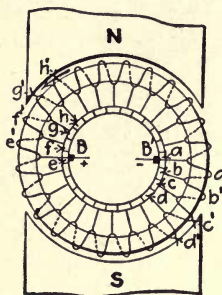

FIG. 358

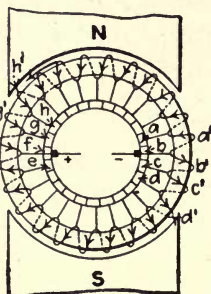

FIG. 359

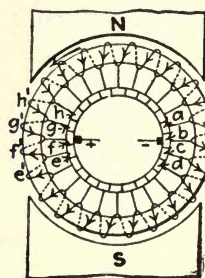

FIG. 360

FIGS. 358 to 360.—Diagrams of a direct-current generator.

the time line and the line *BC* equals the direct-current voltage. Hence, it is apparent that a given armature winding will generate a smaller effective e.m.f. when connected to two slip rings than when connected to a commutator; in other words, the alternating e.m.f. will be less than the continuous e.m.f., the ratio being 0.707 to 1.

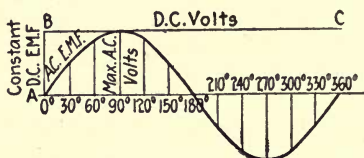

FIG. 361.—Represents a direct-voltage and an alternating voltage.

Relation Between Cycles, Poles and Speed.—It was shown in the foregoing that each time a conductor or group of conductors passes a pole an alternation is generated; therefore the number of alternations per revolution equals the number of poles. Since one cycle equals two alternations, it follows that the

$$\text{Cycles per revolution} = \frac{\text{alternations per revolution}}{2} = \frac{\text{number of poles}}{2} = \frac{p}{2}$$

where p is the number of poles. If S represents the speed of the armature

in revolutions per minute, then the revolutions per second will be $\frac{S}{60}$.

The cycles per second, or frequency, f equals the cycles per revolution $\left(\frac{p}{2}\right)$ multiplied by the revolutions per second $\left(\frac{S}{60}\right)$, or

$$f = \frac{p}{2} \times \frac{S}{60} = \frac{pS}{120}. \quad (1)$$

This is the formula for finding the frequency of an alternator and may be resolved into two others—one for finding the number of poles where the frequency and the speed are known, which is $p = \frac{120 \times f}{S}$; and another for finding the revolutions per minute where the number of poles and the frequency are known, that is, $S = \frac{120f}{p}$.

Since the alternations per revolution equal the number of poles, it follows that the alternations per minute will equal the number of poles times the revolutions per minute, or pS . Substituting in formula (1),

$$f = \frac{\text{alternations per minute}}{120},$$

whence alternations per minute = $120f$.

The following examples illustrate the use of the preceding formulas:

1. Find the frequency and alternations per minute of a 20-pole alternator running at 150 r.p.m.

The frequency, $f = \frac{pS}{120} = \frac{20 \times 150}{120} = 25$ cycles per second. The alternations per minute = $pS = 20 \times 150 = 3,000$.

2. Find the number of poles in a synchronous motor running at 1,200 r.p.m. on a 60-cycle circuit.

$$\frac{120f}{S} = \frac{120 \times 60}{1,200} = 6 \text{ poles.}$$

3. Find the speed of an 8-pole induction motor connected to a 7,200 alternation per minute circuit.

$$f = \frac{\text{alternations per minute}}{120} = \frac{7,200}{120} = 60 \text{ cycles,}$$

and

$$S = \frac{120f}{P} = \frac{120 \times 60}{8} = 900 \text{ r.p.m.}$$

The last formula gives the theoretical, or synchronous, speed of an induction motor; the actual speed is less, the amount depending upon the slip, as will be explained in the chapter on induction motors.

CHAPTER XXII

MEASUREMENT AND ADDITION OF ALTERNATING VOLTAGES AND CURRENT

Instruments for Alternating-current Circuits.—In order to measure alternating currents and voltages, ammeters and voltmeters are used as in the case of direct currents and voltages, but the construction of the instruments is different. In Fig. 108, Chapter VII is illustrated the usual type of direct-current instrument. In it the pointer P is attached to the coil A , which is suspended between the poles I and I of the permanent magnet M . When current passes through the coil A , it is caused to turn because it is in the magnetic field between the poles II . Such an arrangement would not serve to measure an alternating voltage or current, because the current passing through coil A would be constantly reversing its direction, consequently the coil would tend to swing back and forward in unison with the current. As a matter of fact there would be no motion of the coil at all, because the changes in current are so rapid that the coil cannot follow them; before it begins to move in one direction, the current through it has reversed and tries to move it in the opposite direction.

The objections to the direct-current type of instrument are overcome in one form of alternating-current instrument by the use of two coils instead of a single coil and a magnet. A voltmeter of this type is illustrated in Fig. 362. The coil b is similar to the one in the direct-current instrument, but in place of the magnet the stationary coils ff are used. These are connected together at g and are in series with the resistance R and the coil b across the line, which is connected to the terminals TT . The coils ff are in effect an electromagnet, the magnetic field of which reverses for each alternation of the

current through them. The coil *b* is situated in this field, and the current through it reverses in unison with the field. Consequently, the force acting to rotate the coil is always in

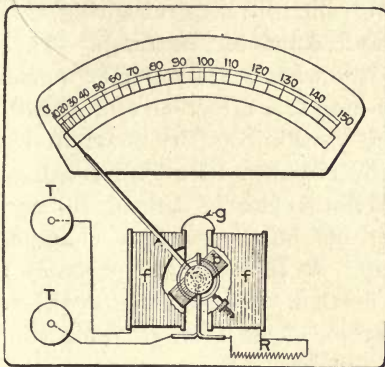

FIG. 362.—Dynamometer type of instrument.

one direction and will cause it to move through a greater or less distance depending upon the magnitude of the current.

Another type of alternating-current instrument is the one illustrated in Fig. 363, known as the inclined-coil type. A

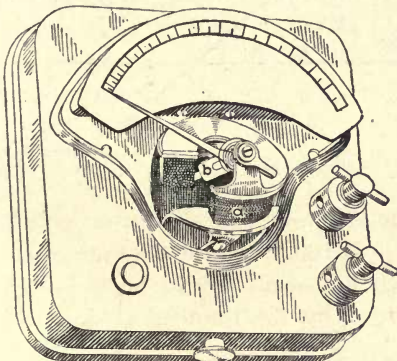

FIG. 363.—Inclined-coil type of instrument.

soft-iron vane *b* is mounted on a shaft, which is perpendicular to the base of the instrument. Vane *b* is mounted on the shaft at about a 45-deg. angle, and the coil *a* inclines at a 45-deg. angle with the base. When current flows through the

coil *a*, a reversing magnetic field is set up by it. The vane *b* tries to turn into a position parallel to the field and in so doing causes the spindle and attached pointer to move. The amount of motion is controlled by a spiral spring.

Voltmeter and Ammeter Readings.—There can be little question as to just what a voltmeter or ammeter should indicate when connected to a direct-current circuit, for the voltage is approximately constant and the current varies only as the resistance of the circuit. In an alternating-current circuit, however, this is not so clearly defined, for here the e.m.f. and the current are not only constantly changing in value, but also in direction. At first thought probably the most logical answer would be that the instruments will read the average value of the curve. This average value could be found by taking a large number of instantaneous values of the curve, adding them together and dividing the sum by the number of values taken. Or, it can be shown mathematically that the average ordinate of a sine curve equals 0.636 times the maximum value.

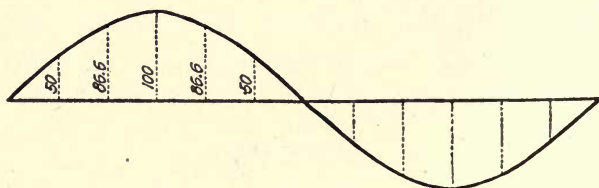

FIG. 364.—Shows how values of a sine curve varies.

Thus, if the curve in Fig. 364 represents a voltage whose maximum value is 100 volts, the average of the instantaneous values for each half-cycle would be $0 + 50 + 86.6 + 100 + 86.6 + 50$ divided by the number of values added together, namely, 6. Hence we have, average value of voltage = $\frac{373.2}{6}$ = 62.2 volts. Owing to the fact that only a few values have been taken, this value is not strictly correct. The exact value is 63.6 volts. However, this average value is not the value that would be recorded by an alternating-current voltmeter,

and as a matter of fact it is of no importance in alternating-current practice and will therefore receive no further attention.

The average value might be indicated on the voltmeter or ammeter were it not for the fact that the effective value of an electric current in a circuit varies as the square of the current times the resistance. This effective value of an electric current is its heating value, and an alternating current is said to be equivalent to a direct current when it produces the same amount of heat. Since this heating effect at any instant does not vary as the current but as the square of the current, it follows that to get the heating effect of the current in an alternating-current circuit at any instant, it will be necessary to square the instantaneous value. Then the average heating effect will equal the average of the square of all the instantaneous values, and the square root of this will give a value equivalent to the direct-current amperes necessary to produce the same amount of heat. Thus, to find the effective value of an alternating current take the square root of the average of the squares of all the instantaneous values. The effective value is often called the square root of mean squares and for a sine curve is equivalent to 0.707 times the maximum value.

As has been stated, the ammeter will read the effective and not the average value of the current. The question may arise as to why the voltmeter reading on an alternating-current circuit will follow the same law. This will be readily understood when it is remembered, as explained in Chapter VII, that as far as the indicating device is concerned, it is alike in both instruments; the difference is in the way they are connected in the circuit. The foregoing may be summarized as follows:

The average of an alternating current or voltage sine curve equals the maximum value $\times 0.636$. *The average value is of very little importance, as it is not what the instruments read and is therefore seldom used. The effective value of an alternating current or voltage sine curve is the maximum value* $\times 0.707$, *or the maximum voltage* $= \frac{\text{the voltmeter reading}}{0.707}$, *and the maximum current* $= \frac{\text{the ammeter reading}}{0.707}$.

The following examples will illustrate the use of these formulas:

1. In a given alternating-current circuit the voltmeter reading is 230, the ammeter reading 75. Find the maximum value of the e.m.f. wave and the maximum value of the current wave.

$$\text{Maximum e.m.f.} = \frac{\text{voltmeter reading}}{0.707} = \frac{230}{0.707} = 325 \text{ volts.}$$

$$\text{Maximum current} = \frac{\text{ammeter reading}}{0.707} = \frac{75}{0.707} = 106 \text{ amperes.}$$

2. Find the ammeter reading and the voltmeter reading of an alternating-current circuit, where the maximum current is 60 amperes and the maximum voltage is 9,350.

$$\text{Ammeter reading} = \text{maximum current} \times 0.707 = 60 \times 0.707 = 42.42 \text{ amperes.}$$

$$\text{Voltmeter reading} = \text{maximum voltage} \times 0.707 = 9,350 \times 0.707 = 6,610 \text{ volts.}$$

Addition of Voltages and Currents.—With direct current the resultant of two or more electromotive forces in series is the sum of the individual electromotive forces. When two sine-wave alternating-current generators of the same frequency are connected in series, the resultant voltage across the two outside terminals will depend upon the phase relation between the two machines and will not necessarily be the sum or the difference of the two e.m.f.'s. Consider two alternators *A* and *B*, of 115 and 75 volts respectively, connected in series, and let it be assumed that the e.m.f.'s of the two machines pass through their corresponding parts of the cycle at the same instant, as indicated by Fig. 365. This condition is usually referred to as the voltages or currents being in step or in phase. In this particular case the voltage across the two machines will be the sum of the two individual e.m.f.'s, or 190 volts. The dotted curve represents the sum of the instantaneous voltage values and is obtained by adding the instantaneous values on the curve of each individual machine; that is, $cd = ac + bc$ and od' , the maximum of the dotted curve, equals oa' , the maximum of curve *A*, plus ob' , the maximum of curve *B*.

If the voltages of the two machines are in direct opposition, as indicated in Fig. 366, the resultant effective e.m.f. will be the difference, or $115 - 75 = 40$ volts. The dotted curve is the resultant e.m.f. wave obtained by taking the

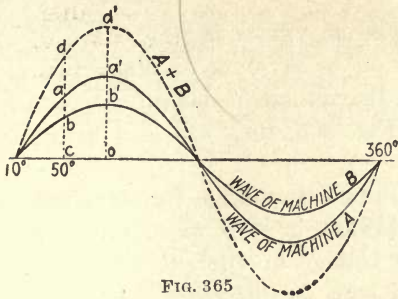

FIG. 365

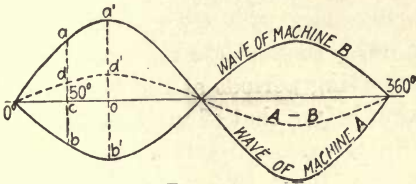

FIG. 366

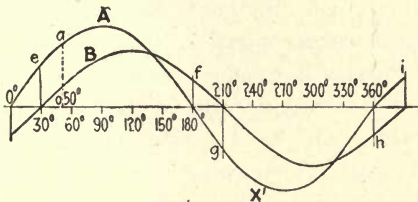

FIG. 367

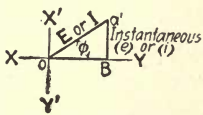

FIG. 369

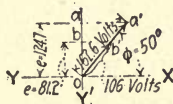

FIG. 373

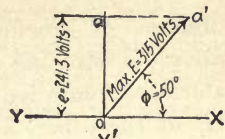

FIG. 371

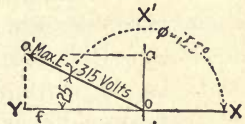

FIG. 372

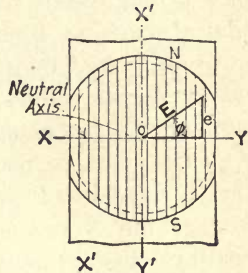

FIG. 368

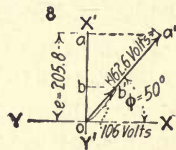

FIG. 374

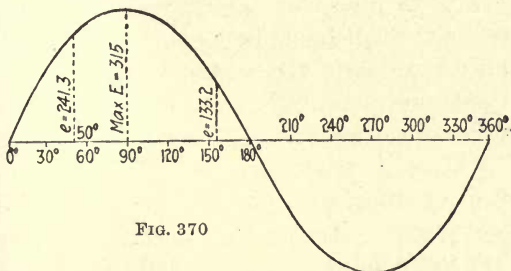

FIG. 370

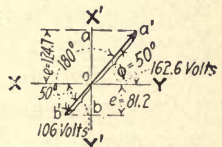

FIG. 375

FIGS. 365 to 375.—Illustrating the combining of alternating voltages and currents by vector diagrams.

difference of the instantaneous values on the curve of each individual machine; thus $od' = oa' - ob'$. When two alternators are connected with the voltage of one directly opposing that of the other, as in Fig. 366, they are said to differ in phase by 180 deg.

In practice, however, the electromotive forces of the individual machines are not always in step, or in direct opposition; hence the resultant voltage or current will not necessarily be the arithmetical sum or difference. For example, consider two alternators in series with their e.m.f.'s in the relation indicated in Fig. 367. In this case the e.m.f.'s do not pass through their corresponding periods at the same instant, that of machine *A* reversing before that of machine *B*. From positions *e* to *f* they are in the same direction; therefore the instantaneous values between these two points will be the sum of the instantaneous e.m.f.'s of the individual curves. At *f* the e.m.f. of machine *A* reverses and is in opposition to that of machine *B* until point *g* is reached, where the e.m.f. of machine *B* becomes zero; consequently from *f* to *g* the resultant instantaneous values will be the difference between those of the individual machines. From *g* to *h* the e.m.f.'s are in the same direction, therefore are added together. During the last period of the cycle from *h* to *i* they are again in opposition, and the resultant will be their difference.

It was shown in Chapter XXI that if the radius of the circle through which a conductor is revolving in a uniform magnetic field is taken to represent the maximum electromotive force, E , the vertical distance between the conductor and the neutral axis represents the instantaneous electromotive force, e , in any position. This is again indicated in Fig. 368, or in simpler form by Fig. 369, which is called a "vector diagram." Here ϕ represents the angle through which the conductor or group of conductors has revolved with reference to the neutral axis. It was also shown in Chapter XXI that the sine of an angle of a right triangle equals the opposite side divided by the hypotenuse. Then in Fig. 369

$$\sin \phi = \frac{e}{E}; \text{ hence } e = E \sin \phi$$

which means that the value

of a sine wave of electromotive force or current at any instant equals the maximum value of the curve times the sine of the angle through which the conductor has passed.

To illustrate this, in Fig. 370 it is assumed that the maximum e.m.f. is 315 volts.

(1) Find the instantaneous value of e at 50 deg.

The sine of 50 deg. is 0.766 (see Table II, Chapter XXI). Hence $e = 315 \times 0.766 = 241.3$ volts. This is shown on the curve, Fig. 370, and the vector diagram, Fig. 371.

(2) Find the instantaneous value of e at 155 deg., Fig. 370.

The sine of 155 deg. is the same as the sine of (180 deg. - 155 deg.) = sine 25 deg. = 0.423. Therefore, $e = 315 \times 0.423 = 133.2$ volts, as indicated in Fig. 370.

The same method applies to a sine wave of alternating current; that is, $i = I \sin \phi$ where i is the instantaneous current and I the maximum current.

By projecting a' horizontally the instantaneous value may be shown on the vertical axis $X'Y'$, as indicated by oa in Figs. 371 and 372. Henceforth the instantaneous value will be represented on the vertical axis.

Fig. 373 is a vector diagram showing the relation between the two e.m.f.'s at the 50-deg. point previously represented by Fig. 365. The line oa' , Fig. 373, represents the maximum pressure of machine A , and ob' the maximum of machine B . Since the voltages are in step, they will coincide, and the vertical distances oa and ob will represent the e.m.f.'s of machines A and B respectively at this instant. If oa' and ob' in the vector diagram are made to equal oa' and ob' on the curve, Fig. 365, then oa and ob in the vector diagram will equal ac and bc respectively on the curves, Fig. 365.

Such a diagram is known as a "polar vector diagram." It is defective in that it does not show the resultant of the maximum or instantaneous values. Fig. 374 is a diagram which overcomes this defect and is known as a "topographic vector diagram." Here the two maximums are combined in their proper phase relation; and where the two e.m.f.'s are in step they will fall in the same straight line and in the same

direction, the resultant being the arithmetical sum of the two. Applying this diagram to the conditions considered in Fig. 365, we have oa' , Fig. 374, corresponding to od' Fig. 365; likewise for the instantaneous values ob and ba , Fig. 374, will equal bc and ac , Fig. 365, respectively. The values of oa and ob may be found as follows:

$$\text{Maximum e.m.f.} = \frac{\text{effective e.m.f.}}{0.707}$$

Therefore, the maximum e.m.f. of machines A and B , Fig. 365, will equal

$$\frac{115}{0.707} = 162.6 \text{ volts} \quad \text{and} \quad \frac{75}{0.707} = 106 \text{ volts, respectively.}$$

In Fig. 373 $oa = oa' \times \sin 50 \text{ deg.}$ As $oa' = 162.6$, and $\sin 50 \text{ deg.} = 0.766$, then $oa = 162.6 \times 0.766 = 124.7$ volts. Also, $ob = ob' \times \sin 50 \text{ deg.} = 106 \times 0.766 = 81.2$ volts. In Fig. 374 $b'a' = oa'$, Fig. 373, hence oa' , Fig. 374, equals $ob' + b'a' = 106 + 162.6 = 268.6$ volts; and $oa = oa' \times \sin 50 \text{ deg.} = 268.6 \times 0.766 = 205.8$ volts. This checks up with the sum of oa and ob , Fig. 373, which is $124.7 + 81.1 = 205.8$ volts.

Fig. 375 is a polar vector diagram of the e.m.f.'s of the generators referred to in connection with Fig. 366. Since the voltages are in direct opposition ob' , which represents the maximum e.m.f. of B , will be drawn 180 deg. from oa' , which represents the maximum e.m.f. of A . In this diagram, as in Fig. 373, there is no line representing the resultant maximum or instantaneous value. Of course they may be found by subtracting ob' from oa' for the resultant maximum, or $162.6 - 106 = 56.6$ volts, and ob from oa for the resultant instantaneous value; that is, $124.7 - 81.1 = 43.6$ volts.

The relation represented in Fig. 367, and again in Fig. 376, may be shown in the same way. Suppose it is desired to find the resultants at the instant when A has passed through 50 deg., as indicated on the curve; since B is 30 deg. behind A , 50 deg. on A will be 20 deg. on B . This condition is indicated in the vector diagram, Fig. 377, where oa' is drawn to scale to represent the maximum of A , making an angle of 50 deg. with the horizontal axis XY , and ob' is drawn to scale to represent the maximum of B , 30 deg. behind oa' . The distances oa and ob on the vertical axis will represent the instantaneous values of A and B respectively, and oa' may be combined with ob' to show the resultant maximum and instantaneous values, as in Fig. 378. Here oa' and ob' have been drawn as in Fig. 377, and then $a'd'$ is drawn parallel to ob' , and $b'd'$ parallel to oa' , forming the parallelogram $oa'd'b'$ with $a'd' = ob'$ and $b'd' = oa'$. The distances oa and ad will equal the voltages of A and B respectively at this instant, and od their resultant, which is equivalent

to cd , Fig. 376. The diagonal od' will equal the resultant maximum voltage of A and B corresponding to od' on the dotted curve, Fig. 376.

The maximum e.m.f.'s of machines A and B are the same as in Figs. 365 and 373. The resultant maximum od' , may be calculated from the formula,

$$(od')^2 = (oa')^2 + (a'd')^2 - 2oa' \times a'd' \times \cos U.$$

Angle $U = 180 \text{ deg.} - \text{angle } \theta = 180 \text{ deg.} - 30 = 150 \text{ deg.}$, and $\cos 150 \text{ deg.} = -\cos 30 \text{ deg.}$, or -0.866 .

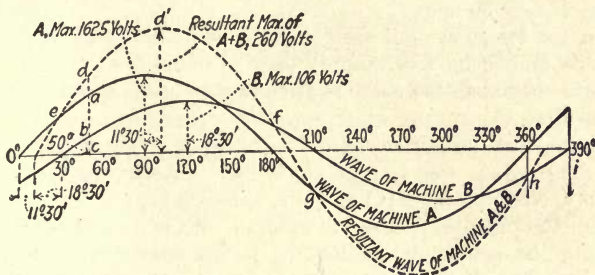

FIG. 376

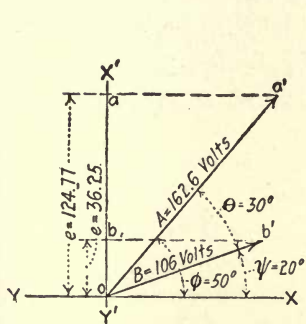

FIG. 377

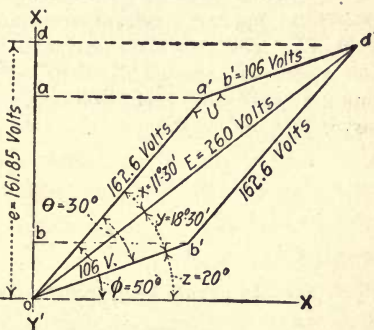

FIG. 378

FIGS. 376 to 378.—Addition of two alternating voltages on currents when they are out of phase.

Substituting the numerical values,

$$(od')^2 = (162.6)^2 + (106)^2 - [2 \times 162.6 \times 106 \times (-0.866)] = 67,526.82,$$

whence $od' = 260$ volts, approximately.

Again,

$$(a'd')^2 = (od')^2 + (oa')^2 - (2 \times od' \times oa' \cos x)$$

and

$$\begin{aligned}\cos x &= \frac{(od')^2 + (oa')^2 - (a'd')^2}{2 \times od' \times oa'} \\ &= \frac{(260)^2 + (162.6)^2 - (106)^2}{2 \times 260 \times 162.6} = 0.980.\end{aligned}$$

Referring to Table II (Chapter XXI) it will be found that the cosine of 11 deg. = 0.982 and that of 12 deg. = 0.978. As 0.980 lies between these values, the angle x will be 11 deg. 30 min., and angle $y = 30$ deg. - 11 deg. 30 min. = 18 deg. 30 min.

From the foregoing it is seen that the resultant of oa' and ob' falls 11 deg. 30 min. behind oa' and 18 deg. 30 min. ahead of ob' . This is the position of the dotted curve relative to the curves A and B , as shown in Fig. 376.

The resultant instantaneous value of od is found by the formula $od = od' \times \sin(y+z)$; that is, $e = E \sin(y+z)$. Substituting the numerical values of $e = 260 \times 0.6225 = 161.85$ volts, approximately.

The method used in finding the resultant maximum and instantaneous values may be applied in finding the resultant effective value. Also, inasmuch as the effective value of a sine curve equals the maximum times 0.707, the effective voltage across the two machines may be obtained by multiplying the resultant maximum, as found in Figs. 376 and 378, by 0.707. The resultant maximum in Figs. 376 and 378 is 260 volts. The voltmeter reading $E \times 0.707 = 260 \times 0.707 = 183.8$ volts. The combining of two sine curves produces a third curve, which is itself a sine curve.

CHAPTER XXIII

TWO-PHASE AND THREE-PHASE CIRCUITS.

Two-phase Systems.—The alternating-current circuits dealt with in the preceding chapters were single-phase. So long as alternating current was used only for lighting purposes, the single-phase system gave complete satisfaction. With its advent into the power field, however, the difficulty arose of making the single-phase motor self-starting without employing some auxiliary starting device at the expense of ruggedness and simplicity of construction.

Ferarris in 1888 discovered that a rotating magnetic field could be produced by two or more alternating currents displaced in phase from one another. This led to the development of the polyphase systems.

Instead of revolving one conductor about an axis in a magnetic field, as in Figs. 345 and 346, Chapter XXI, let two conductors be arranged 90 deg. apart, as in Fig. 379. It is obvious in this arrangement that when conductor *A* is on the vertical axis generating a maximum e.m.f., conductor *B* will be on the horizontal, or neutral axis and its e.m.f. will be zero. As the conductors move in the circular path as indicated, the e.m.f. generated in *A* will decrease and that in *B* increase until they are in the position shown in Fig. 380, where the voltage in *A* will be zero, while that in *B* will be a maximum. From this it is seen that the e.m.f.'s generated in *A* and *B* will pass through the same series of values, but when one is at a maximum the other will be at zero. Curves *A* and *B*, Fig. 381, show the relation between the two e.m.f.'s, which are said to be 90 electrical degrees apart. To produce this combination of e.m.f.'s the conductors will be 90 space degrees apart only on a two-pole machine; on a four-pole machine

they will be 45 space degrees apart; on a six-pole machine 30 deg. apart; and on an eight-pole machine 22.5 deg. apart.

Fig. 382 shows the same arrangement of coils and pole-pieces as in Figs. 354 to 357, Chapter XXI, but in this case four collector rings are used instead of two. If the four rings are connected to the winding at equidistant points around the armature, in this case 90 deg., when the armature is in the position indicated, a maximum e.m.f. will be generated between collector rings *a* and *a'* and zero between *b* and *b'*. When the armature has revolved through 90 deg. to the position indicated in Fig. 383, the e.m.f. between rings *a* and *a'* will have decreased to

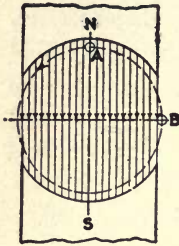

FIG. 279

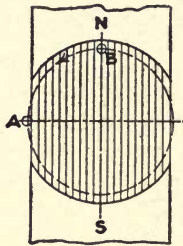

FIG. 380

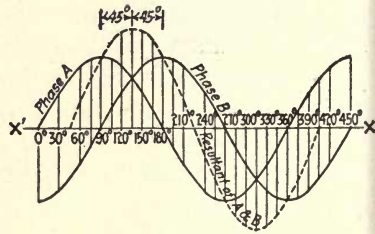

FIG. 381

FIGS. 379 to 381.—Illustrate in an elementary way how a two-phase voltage is generated.

zero, while that between *b* and *b'* will have increased to a maximum.

Three-wire Two-phase Systems.—From the foregoing it is evident that two e.m.f.'s may be taken from the same winding, which are 90 electrical degrees apart. This is the same as was generated by the two conductors, Figs. 379 and 380; therefore curves *A* and *B*, Fig. 381, show the relation between the e.m.f.'s taken from collector rings in Figs. 382 and 383.

In practice, instead of using a ring armature with one winding as in Figs. 382 and 383, two windings are used similar to the arrangement shown in Fig. 384, which represents a four-pole two-phase alternator. In this winding there are 16 coils per circuit, or as it is usually termed, 16 coils per phase. One phase of the winding is shown shaded and the

other unshaded. The windings are so distributed that when the winding of phase *A* is under the polepieces and will therefore be generating a maximum e.m.f., that of phase *B* will be between the polepieces, consequently the e.m.f. in it will be zero; hence the e.m.f.'s generated by these two windings will be the same as those generated by the ring armatures, Figs. 382 and 383.

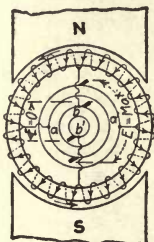

FIG. 382



FIG. 383

FIGS. 382 to 383.—Diagrams of two-phase alternators.

For simplicity the conventional diagram of Fig. 385 may be used to represent the two phases, indicating that the two windings are displaced 90 electrical or time degrees on the armature. A more convenient way is shown in Fig. 386, especially where the windings are grouped.

So far only the four-wire two-phase system has been considered. When a winding is used for each phase, as in Fig. 384, they may be connected in series and a common terminal brought out, as in Fig. 387, which is known as a three-wire two-phase system. This would be impossible with only one winding, for if any two of the rings were together it would short-circuit the winding.

Since the e.m.f.'s of the two phases are out of step by 90 deg., the voltage between the two outside terminals, Fig. 387, will not be their arithmetical sum but the resultant, as explained in Chapter XXII. Fig. 388 is a simple vector diagram showing the relation between the two e.m.f.'s of a two-phase circuit.

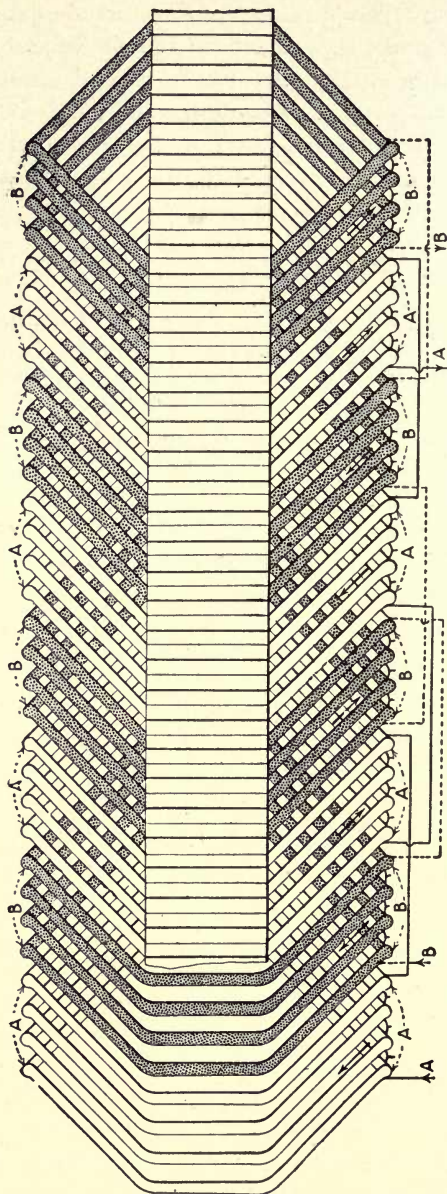
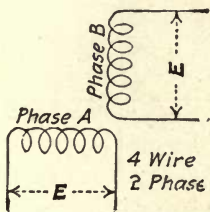
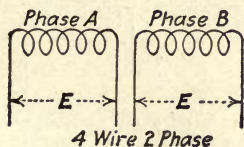

Fig. 384.—Diagram of a two-phase four-pole winding.

By adding the two e.m.f.'s vectorially, the parallelogram $OACB$, Fig. 389, is formed, the diagonal OC being the resultant of the two voltages and representing to scale the pressure between the two outside terminals in Fig. 387. In this case since the two e.m.f.'s are equal, the parallelogram will be a square, and the diagonal of a square equals one side multiplied by $\sqrt{2}$. If it is assumed that the effective e.m.f. of each phase is 135 volts, the pressure between the two outside terminals will be $135 \times 1.414 = 191$ volts approximately.



F.g. 385



F.g. 386

FIGS. 385 and 386.—Four-wire two-phase diagrams.

The same relation holds with the current; that is $I' = I\sqrt{2}$, where I' is the current in the middle wire and I that in either outside leg, where the current of each phase is the same. assume the current per phase, Fig. 387, to be 35 amperes, the current in the middle wire is $I' = I\sqrt{2} = 35 \times 1.414 = 49.5$ amperes.

The foregoing statements may be verified by combining the two curves in Fig. 381, as indicated by the dotted curve, which is obtained by adding algebraically the instantaneous values on the curve of each phase. The maximum of this resultant curve is 1.414 times that of A or B ; furthermore, the dotted curve is displaced from A and B , being 45 deg. behind A and 45 deg. ahead of B .

Since the current in the center wire of a balanced three-wire two-phase circuit is 1.414 times that carried by either of the outside wires, the copper in the center conductor will have to be 1.414 that of one of the outside conductors. From this it is evident that the saving in copper in the three-wire system over that of a four-wire is not as great as might be expected;

that is, the copper in the former is 85 per cent of that in the latter.

The expressions $E' = E\sqrt{2}$ and $I' = I\sqrt{2}$ hold true only where the e.m.f. across, or the current in, each phase is the same. In Fig. 390 if the voltage of phase A be represented by E_1 , that of phase B by E_2 and the voltage between the two outside legs by E' , then $E' = \sqrt{E_1^2 + E_2^2}$, which can be used where the voltages of the two phases are not equal. To find the current in the center leg where the current in the two phases

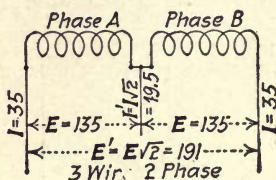

FIG. 387

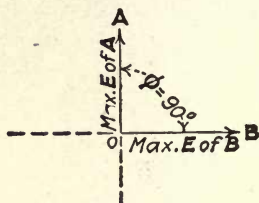

FIG. 388

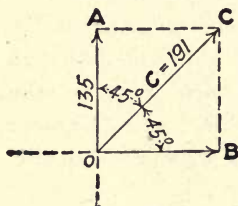

FIG. 389

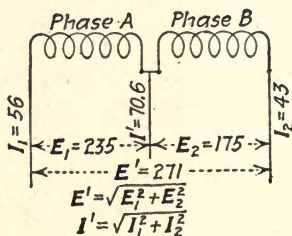

FIG. 390

FIGS. 387 to 390.—Three-wire two-phase diagrams.

differ in value, the foregoing may be changed to $I' = \sqrt{I_1^2 + I_2^2}$, where I' is the current in the middle wire and I_1 and I_2 that in phases A and B respectively.

Assuming that in the three-wire two-phase circuit, Fig. 390, the voltage of phase A is 235 and that of phase B 175 volts, and the current in phase A 56 amperes and in phase B 43 amperes, let it be required to find (1) the e.m.f. between the two outside terminals and (2) the current in the center leg of the circuit.

$$E' = \sqrt{E_1^2 + E_2^2} = \sqrt{235^2 + 175^2} = 271 \text{ volts.} \quad (1)$$

$$I' = \sqrt{I_1^2 + I_2^2} = \sqrt{56^2 + 43^2} = 70.6 \text{ amperes.} \quad (2)$$

Figs. 391 and 392 are vector diagrams of the voltage and current respectively of Fig. 390.

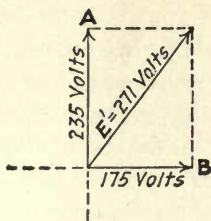

FIG. 391

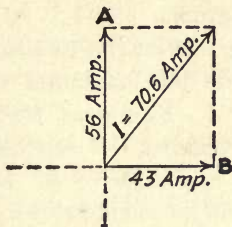

FIG. 392

Figs. 391 and 392.—Addition of two-phase voltage and currents by vector diagrams.

In practice the e.m.f.'s are seldom very much out of balance on a two-phase system. Where a lighting system is supplied from a two-phase circuit, the current can be almost any value in the two phases, depending on how the load is distributed, although efforts are usually made to keep it as nearly balanced as possible.

Three-phase Systems.—The alternating-current system that is used more at present than any other is the three-phase. If three conductors are spaced 120 deg. apart in a two-pole magnetic field, as shown in Fig. 393, and revolve about an axis as indicated by the dotted circle, each conductor will generate a sine wave of electromotive force just as did the single conductor in Figs. 345 and 346, Chapter XXI. Since the conductors differ in location by 120 deg. the e.m.f. generated in them will differ in phase by 120 electrical or time degrees. Rotating the conductors in the direction of the curved arrow will induce in them, at the instant shown, an e.m.f. in the direction indicated by the dot and cross in the center of the circles representing the conductors. The direction of the e.m.f. in *A* is up through the plane of the paper, while that induced in *B* and *C* is away from the reader. Furthermore, conductor *A* at this instant is on the vertical axis of the magnetic field and is therefore generating a maximum pressure, while conductors *B* and *C* are located in the position between the vertical and horizontal axis and are therefore generating

an e.m.f. of a value somewhere between zero and maximum. Just what this value is can probably best be explained by a vector diagram.

In Fig. 394 on the vertical axis YY' lay off OA representing to scale the maximum value of the e.m.f. generated in conductor A . Next draw OB 120 deg. in a clockwise direction from OA making OB represent to scale the maximum e.m.f. generated in conductor B . Since B travels through the same path and at the same rate as A , the maximum e.m.f. in B will equal that in A , therefore OB will equal OA . Draw OC 120

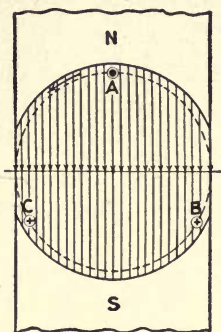

FIG. 393

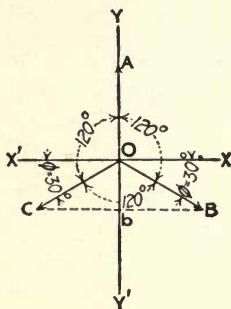

FIG. 394

FIGS. 393 and 394.—Illustrate in an elementary way how a three-phase voltage is generated.

deg. in a clockwise direction from OB to represent to scale the maximum e.m.f. generated in C . For the reason already set forth, OC will also equal OA . The positions of OA , OB and OC correspond to the positions of the conductors A , B and C respectively in the magnetic field, as represented in Fig. 393.

The projections of OA , OB and OC on the vertical axis will represent to scale the value of the e.m.f. generated in the conductors at this instant, as explained in Chapter XXII. Since OA coincides with the vertical axis YY' , its projection on this axis will be equal to its total value, which indicates that the e.m.f. generated in A at this instant is at a maximum. By projecting OB horizontally to YY' , distance Ob is obtained; this represents to scale the instantaneous value of the

e.m.f. generated in *B*. The projection of *OC* also gives the value *Ob* for the e.m.f. generated in *C*. This is what would be expected when the positions of *B* and *C* in the magnetic field are considered, as both are in similar positions but under opposite sides of the polepiece; hence at this instant the voltage generated in each will be equal.

In Chapter XXII it was explained that the instantaneous value *e* of the e.m.f. can always be found by the formula: $e = \text{Max. } E \sin \phi$. In Fig. 394 the value of ϕ with reference to *OB* and *OC* equals $120 \text{ deg.} - 90 \text{ deg.} = 30 \text{ deg.}$ $\sin 30 \text{ deg.} = 0.5$, hence $e = \text{Max. } E \times 0.5$. That is, *Ob*, which

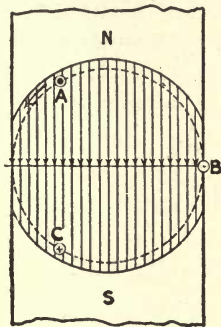

FIG. 395

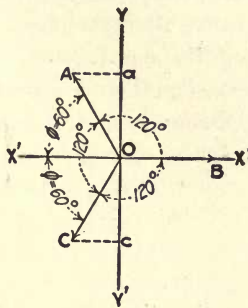

FIG. 396

FIGS. 395 and 396.—Same as Figs. 393 and 394, except conductors are revolved thirty degrees.

represents to scale the value of the e.m.f. generated in *B* or *C* at this instant, is equal to one-half that generated in *A*, which is at a maximum value. The voltage generated in *B* and *C* at this instant is in the same direction, therefore the combined e.m.f. of *B* and *C* is equal and opposite to that in *A*. For the direction of motion shown, the e.m.f. in *B* is decreasing while that of *C* is increasing.

When the conductors have revolved 30 deg. from the position of Fig. 393, they will be located in the magnetic field, as indicated in Fig. 395. This brings *B* on the horizontal axis, therefore the pressure in it has decreased to zero, and *A* and *C* occupy similar positions in the magnetic field, but under

opposite polepieces; consequently the e.m.f. generated in them at this instant will be equal and opposite. This condition is shown in the vector diagram, Fig. 396. Since OB coincides with the horizontal axis, its projection on the vertical will be zero, and this corresponds with the value of the e.m.f. generated in B . The horizontal projections Oa and Oc on the vertical axis represent the values of the e.m.f. generated in A and C at this instant respectively. Since angle $\phi = 60$ deg. for either OA or OC the e.m.f. generated in A will equal that generated in C , but will be opposite in direction. Since $\phi = 60$ deg., and $\sin 60$ deg. = 0.866, $e = \text{Max. } E \times 0.866$. In other words, the voltage generated in A and C at this instant is 0.866 times the maximum value. Again, it is evident that the sum of the e.m.f. generated in the conductors under one polepiece is equal and opposite to that generated under the other polepiece.

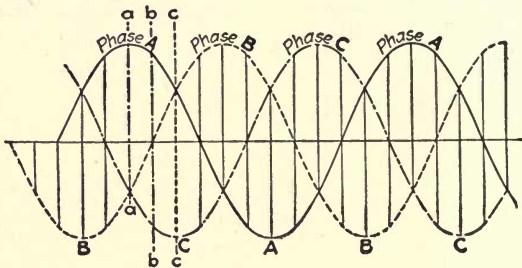

FIG. 397.—Three-phase voltage or current curves.

What has been shown for the two positions of the three conductors—namely, the sum of the e.m.f.'s generated in the conductors under one polepiece is equal and opposite to the sum of the e.m.f.'s generated in the conductors under the other pole—is true for any position. This is illustrated in Fig. 397, which shows the curves generated by the three conductors, Figs. 393 and 395. Since the conductors are 120 deg. apart, the curves will also be displaced from each other by 120 time degrees. Referring to the instant marked a on the curves, it is seen that curve A is at a maximum above the time line when B and C are at half value below the line, which

indicates they are opposite in polarity to A , which is just the condition represented in Fig. 393. At the instant marked b on the curves, which is 30 deg. from a , the value of B has decreased to zero, while that of A has decreased and that of C is increased until they are the same value but in the opposite direction; which is the same condition as that represented in Fig. 395. *At any instant the sum of the instantaneous values above the line is equal to the sum of the values below the time line.*

Three-phase Machine with Ring Armature.—What has been explained for three conductors revolving about an axis in a magnetic field is also true for three groups of conductors located 120 deg. apart, as represented in the ring armature, Fig. 398. Here the same arrangement of coils and polepieces is used as that for the one- and two-phase machines, but in this instance the winding is connected at three equidistant points to three slip-rings. Considering the position of the armature shown, it will be seen that the conductors between A_1 and A_2 are in a position to generate a maximum e.m.f. Between B_1 and B_2 the voltage in a 30 deg. section of the winding above the axis XX' is in opposition to that below this axis, therefore this will leave only a 60-deg. section of the winding effective to the right of B_2 to produce e.m.f. between B_1 and B_2 ; this is just one-half of that between A_1 and A_2 at this instant. For the same reason the pressure is only one-half between C_1 and C_2 that it is between A_1 and A_2 . This is just what existed in the three conductors, Fig. 393.

If the armature is turned through 30 deg. as in Fig. 399, the e.m.f. between B_1 and B_2 will decrease to zero, as the voltage generated in one-half of the winding between these two points is opposite to that generated in the other half, as indicated by the arrowheads. It is evident also that the e.m.f. between A_1 and A_2 is equal to that between C_1 and C_2 , but in the opposite direction. This corresponds to the condition in Fig. 395, also as illustrated on the three-phase sine curves at the point marked b , Fig. 397.

The three different groups of conductors on the armature,

Figs. 398 and 399, have generated in them the same series of values of e.m.f., therefore the voltage between any two of the brushes will be the same. Hence we have a three-wire system having three equal voltages displaced in phase by 120 deg. This is just the condition in a three-wire three-phase circuit.

In a commercial machine, instead of using a ring windings, as in Figs. 398 and 399, three windings are used, one for each

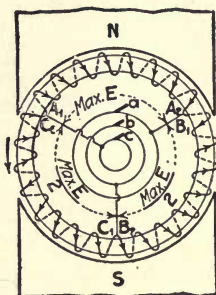

FIG. 398

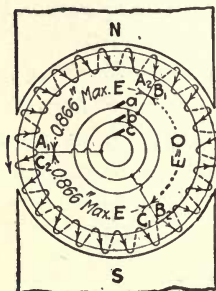

FIG. 399

Figs. 398 and 399.—Three-phase alternators.

phase, distributed in groups according to the number of poles. One type of such a winding is shown in Figs. 400 and 401. These windings have 48 coils grouped for a four-pole machine, which gives four coils per pole per phase; each individual group is lettered *A*, *B*, and *C* respectively.

Delta and Star Connections.—The scheme of grouping the three phases in Figs. 398 and 400 is called a delta (Δ) or mesh connection. When combined in this manner, they form an equilateral triangle, as indicated in Fig. 402. Frequently the windings are shown diagrammatically connected in the form of a triangle, as in Fig. 403 or as in Fig. 404. At first thought it may appear that the three windings are connected so as to cause a short-circuit. It is obvious that this is not the case when it is remembered that the e.m.f.'s in a three-phase circuit are in such a relation that their algebraic sum at any instant is equal to zero, therefore the potential between points A_1 and C_2 , Fig. 404, is zero. In the delta-connected winding it is evident that the voltage between terminals is

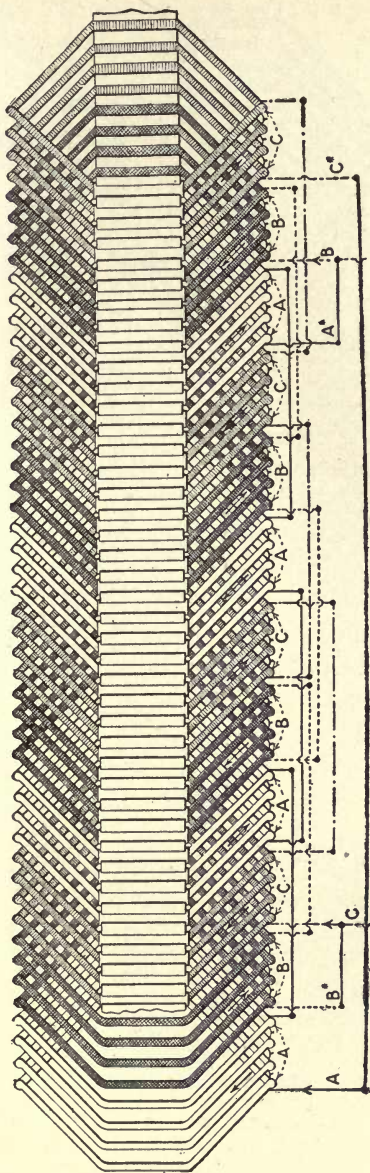

FIG. 400.—Diagram of three-phase four-pole delta-connected winding.

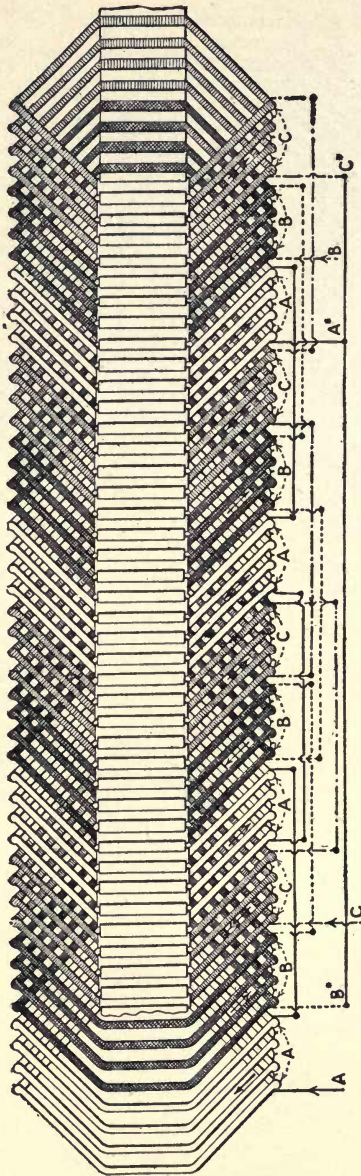

FIG. 401.—Diagram of three-phase four-pole star-connected winding.

that per phase. The current per terminal cannot be the current per phase, as each leg of the circuit connects to two different phases; therefore the current leaving or entering at any one of the junctions between the phases will be some resultant of the current in the two phases. In a balanced three-phase system (that is, where the current in each phase is

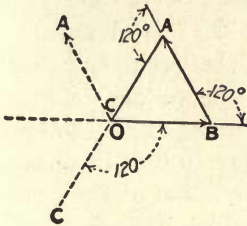
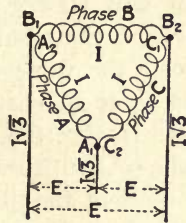

FIG. 402



F.G. 403

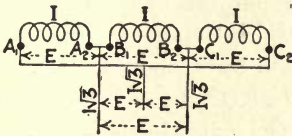

FIG. 404

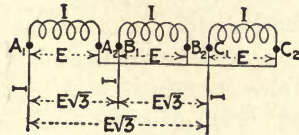

FIG. 405

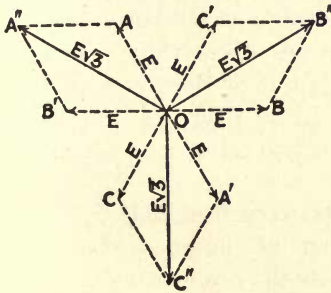

FIG. 406

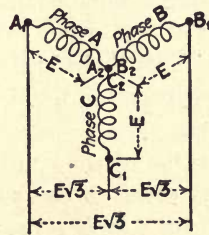

FIG. 407

FIGS. 402 to 407.—Diagrams of three-phase circuits.

the same value) which is delta-connected, the current per terminal will be that of one phase times the square root of three. If the current per phase is represented by I , the current per terminal will equal $I\sqrt{3}$. The correct relation of voltage and current in a three-phase delta-connected system is indicated in Figs. 403 and 404.

Connecting A_2 to B_2 as in Fig. 405, changes the relation of the e.m.f. in phase B by 180 deg. from that in Fig. 404; hence, if OA , OB and OC , Fig. 406, represent the phase relation of the three e.m.f.'s of Fig. 404, OB' will represent the relation of the e.m.f. in phase B to that of phase A when connected as in Fig. 405. Here it is seen that the e.m.f. in A and B differ by only 60 deg. instead of 120 deg.; combining the two vectorially, the resultant OA'' is obtained, which represents to scale the value of E between A_1 and B_1 , Fig. 405. Connecting C_2 to B_2 changes the voltage relation of phase C by 180 deg. In Fig. 406, if OC represents the position of the e.m.f. in phase C with reference to that in phase B , Fig. 404, OC' will represent the phase relation of the e.m.f. in phase C to that in phase B , Fig. 405, which indicates that the e.m.f. in C differs in phase by only 60 deg. from that in B . Completing the parallelogram, the resultant OB'' is obtained, which represents to scale the value of E between the terminals B_1 and C_1 . C_2 is also connected to A_2 instead of A_1 , as was done in Fig. 404. This changes the relation of the e.m.f. in phase A to that in phase C by 180 deg., and is indicated by OA' , Fig. 406, and the resultant OC'' gives the value of E between the terminals C_1 and A_1 . This combination gives three equal resultant e.m.f.'s 120 deg. apart; the value of these resultants in terms of E per phase is indicated on the diagram. Such a combination as represented in Fig. 405 is called a γ (gamma) or star connection.

The value of the e.m.f. between terminals with a star connection is equal to the voltage of one phase times the square root of three. If E represents the e.m.f. per phase, then $E\sqrt{3}$ represents the voltage between terminals. It is evident that the current per terminal in the star connection is the same as that per phase as indicated in Fig. 405. The star connection is sometimes represented by the conventional Fig. 407. Fig. 401 shows how to group the three windings of Fig. 400 in a star connection. For a complete practical treatise on windings for alternating-current machinery the reader is referred to Mr. A. M. Dudley's admirable book, "Connecting Induc-

tion Motors," from which Figs. 384, 400 and 401 are taken. Mr. Dudley's book is published by the McGraw-Hill Book Co.

Alternating-current generators may be wound for any number of phases, but in practice they are never constructed for more than three. Alternating-current systems of more than one phase are referred to as polyphase systems, such as, a two- or a three-phase system.

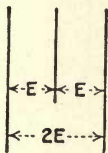

FIG. 408

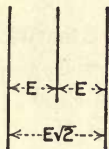

FIG. 409

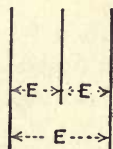

FIG. 410

FIGS. 408 to 410.—Show voltage relations on an Edison three-wire, a three-wire two-phase and a three-wire three-phase circuit.

In general there are three types of three-wire circuits: (1) The Edison three-wire system, where the voltage between the two outside legs of the circuit is twice that between either outside and center leg, as in Fig. 408; this system may be either direct or alternating current. (2) A three-wire two-phase system, in which the potential between the two outside terminals is that between the outside and center terminal times the square root of two, as indicated in Fig. 409; such a system can be alternating current only. (3) The three-wire three-phase system, either delta- or star-connected; in this combination the voltage between any two terminals is the same as shown in Fig. 410, and can be alternating current only. Obviously either system may be easily identified by the voltages between its terminals. For a determination of the power in alternating-current circuits, see Chapter XXV.

CHAPTER XXIV

OPERATING ALTERNATORS IN PARALLEL.

Condition for Parallel Operations.—When attempting to operate alternators in parallel, it is necessary to observe the same precautions as in the case of direct-current generators, namely, that their voltages are of the same value and in the same direction. The latter of these requirements is more difficult of fulfillment in the case of alternators, since the direction of their voltages is continually changing. To make clear the relations that exist, it will be convenient to refer back to the parallel operation of direct-current generators.

Suppose that two such generators are connected together as illustrated in Fig. 411. When the polarities are as shown, each generator will deliver half of the power if they both generate the same voltage. Suppose now that the generators have been connected with opposite polarities, as shown in Fig. 412. A very large current would then instantaneously flow through the machines by way of the leads *A* and *B*, but no current would be delivered to the load through the leads *C* and *D*. As a matter of fact, the condition existing would be a short-circuit. We might illustrate the conditions of Figs. 411 and 412 by hydraulic analogies, as in Figs. 413 and 414. In Fig. 413 we have two centrifugal pumps that are rotated in the same direction and deliver the same pressure. The flow of water will be from *a* and through P_1 to the pipes *p*, and thence by way of P_2 back to b_1 and b_2 . Suppose now, that pump 2 were to be connected in reverse, as indicated in Fig. 414. It would in consequence pump water from a_2 to b_2 , so that all the water pumped from b_1 to a_1 through pump 1 would pass through pump 2 and return to b_1 to go through the two pumps again and again. That is, water would merely be circulated

around between the two pumps without causing any flow of water through the pipes p .

Let us assume that the rotary pumps are replaced by

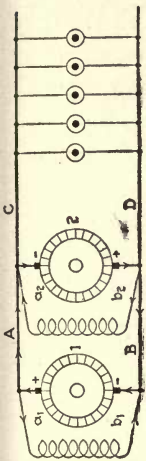

FIG. 412

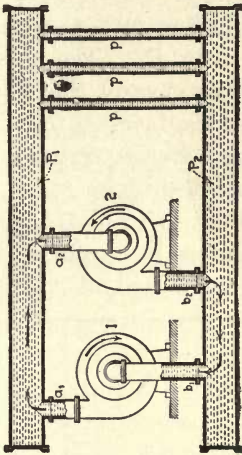

FIG. 414

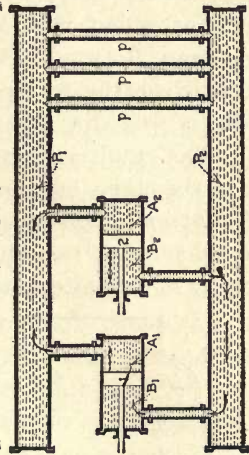

FIG. 415

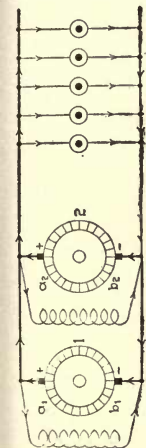

FIG. 411

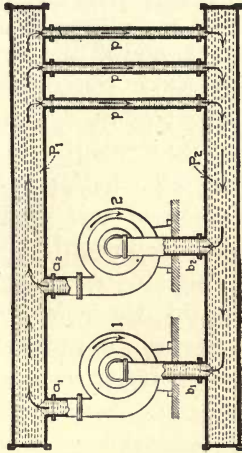

FIG. 413

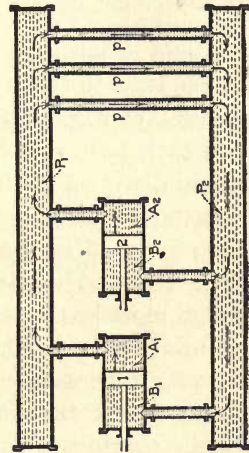

FIG. 416

FIGS. 411 to 416.—Diagrams of direct-current machines connected in parallel and hydraulic analogies of direct-current and also alternating-current machines in parallel.

plunger pumps, as illustrated in Figs. 415 and 416. If both pistons are traveling from left to right as indicated by the arrows in Fig. 415, water will be forced from A_1 and A_2 into P_1 , through p to P_2 and back into B_1 and B_2 . On the other

hand, if piston 2 were moving from right to left when piston 1 is moving from left to right, as in Fig. 416, the space A_2 would increase as fast as A_1 decreased, and similarly B_1 would increase as fast as B_2 decreased. Consequently, whatever water is forced out of A_1 would flow into A_2 and all the water forced from B_2 would flow into B_1 . The same conditions would exist on the return stroke, except that the flow would be in the reverse direction; that is, from A_2 to A_1 and from B_1 to B_2 . The result is that the water is transferred from one pump to the other, but none flows through p .

The foregoing examples, Figs. 415 and 416, may be likened to the behavior of two alternators in parallel. Thus, in Fig. 417 we have two alternators connected in multiple to a load

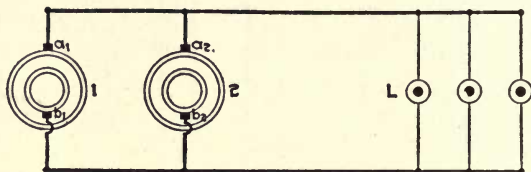

FIG. 417.—Simplified diagram of two alternators connected in parallel.

L . If a_1 and a_2 are both positive, and at the same stage of a cycle—that is, if the alternators are in phase—we would have the condition of Fig. 5 and current would flow from a_1 and a_2 to L and back to b_1 and b_2 during one-half of a cycle and in the reverse direction during the other half.

From the foregoing it is apparent that to prevent short-circuits between alternators when connected in parallel, they must be connected together when in phase, and that their frequencies must be the same at that time. We therefore have three things to observe when about to connect an alternator in parallel with others, namely, that its voltage is the same as that of the mains, that it is in phase with the main voltage, and that it is running at the same frequency as the rest of the systems. Once an alternator has been connected to the system, its frequency will be that of the system, under all ordinary conditions. Thus, if its prime mover tended to slow down, the alternator would act as a motor and take power

from the other machines to cause the prime mover to maintain its speed. On the other hand, if the prime mover tried to speed up, it would tend to increase the frequency of its alternator, and this it could do only by increasing the frequency of all the other machines connected in parallel with that alternator.

Adjusting Load on Two or More Alternators.—The fact that all the machines on a system run in unison at all times, is the cause for a feature in the parallel operation of alternators that differs widely from the similar operation of direct-current generators, namely, the manner in which the load on the system is divided among the machines. When it is desired that a direct-current generator shall take a greater proportion of the load on the system, its field flux is increased by cutting resistance out of its field rheostat, thus causing an increase in generated voltage and a corresponding increase in the load current. The increase in load results in a slight slowing down of the prime mover, sufficient to cause the governor to admit the additional steam or water required by the added load.

An attempt to increase the load of an alternator in the foregoing manner would, however, result in failure. The speed of the machine being fixed by the frequency of the system to which it is tied, an increase of field current can only increase the generated voltage, but cannot make the machine slow down, and hence cannot make the governor admit more steam. Consequently, the alternator cannot assume more of the load, and the field-current adjustment does not change the load distribution. It is found, however, that such an increase in generated voltage causes a current to circulate between the generator of higher voltage and those of a lower voltage, thereby causing a greater current to flow through them than that required by the load, and consequently causing an unnecessary loss in the machines. It is therefore a part of correct parallel operation to see to it that all the machines have like excitation.

The prime movers of alternators should be equipped with governors that can be adjusted while the machines are in

operation. Then, when the load is to be increased, the governor is adjusted slightly, causing it to admit more steam or water, as the case may be. This will tend to cause the machine to increase in speed. However, a very slight increase in speed will serve to make the alternator take a greater share of the load than before, and so reduce the load on the others.

Putting an Alternator Into Service.—As pointed out in the foregoing that in order to operate two or more alternators in parallel, it is necessary that they be of the same voltage, of the same frequency, and that they be in phase. The first of these requisites is readily determinable by means of a voltmeter. To determine the other two, several devices may be employed. Of these the simplest is that in which two ordinary incandescent lamps are used. In Fig. 418 are two single-phase

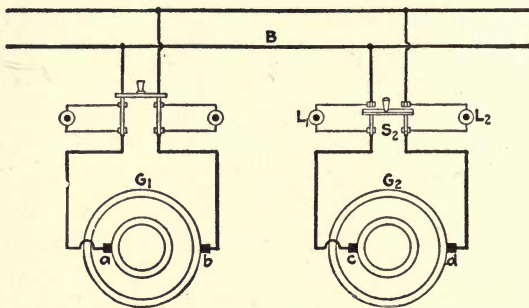

FIG. 418.—Connections for synchronizing two single-phase alternators; lamps dark.

alternators, G_1 and G_2 , with G_1 connected to the busbars B . Suppose that it becomes necessary to put G_2 into service also. Having started G_2 and brought it up to normal speed, its voltage is adjusted to be the same as that of the mains. At switch S_2 lamps L_1 and L_2 have been connected in the manner shown and these lamps should flicker. If the two alternators are almost at the same speed the flickering of the lamps can readily be followed by the eye; they will slowly light up to full brilliancy and then as slowly dim down to complete darkness, only to light up again. This will continue with perfect regularity so long as the speeds of the generators remain

exactly as they are. Any change in speed, however slight, causes a change in the intervals of brightness and darkness of the lamps.

Having found that the lamps flicker, the speed of G_2 is changed slightly and the effect on the lamps noted. If the flicker becomes more rapid it is an indication that the speed has been changed in the wrong direction. If it becomes less rapid, it is known that the speed is more closely approaching that of G_1 . Finally, when there is no flicker it is proof that the two speeds are exactly the same. If the lamps are burning brightly when the flickering ceases, it is a sign that G_2 is 180 deg. out of phase with G_1 and that a short-circuit would occur if S_2 were closed, even though the generators are running at the same speed. If the lamps are burning dimly, it is an indication that the machines are out of phase by some angle less than 180 deg., under which condition it is still not permissible to close S_2 . When G_2 is in phase with G_1 , the lamps remain dark. Thus, if they die down to darkness and then do not again light up, it is known that the two machines have been brought into phase and it is safe to close switch S_2 , thereby connecting G_2 in parallel with G_1 . This process is frequently referred to as synchronizing the two machines and when they are in phase they are said to be in synchronism.

It is not usual to attempt to get the absolutely ideal condition indicated by the lamps not lighting up at all. Ordinarily, the speed adjustment is made until the lamps are flickering very slowly; that is, until it takes several seconds for the lamps to light up, dim down, and light up again. We know then that the speeds of the two machines differ only very slightly. The lamps are watched as they slowly grow dimmer and dimmer and finally become entirely dark. During this period and before they again begin to light up, the switch S_2 is closed.

Sometimes the lamps are connected as in Fig. 419; then the instant of synchronism is that at which the lamps are at full brilliancy—just the opposite from Fig. 418. This method has the advantage that if one of the lamps should happen to

burn out, the fact will become manifest by the lamps refusing to light up under any manipulation of speed by the operator, and he will not be led to believe that the machines are in synchronism, as might be the case if the "dark" method were used. On the other hand, the precise instant of synchronism can be so much more readily judged in the case of the dark method, and the likelihood of an operator being deceived by the accidental burning out of a lamp is so slight that the "dark" method is in greater use than the "light" one.

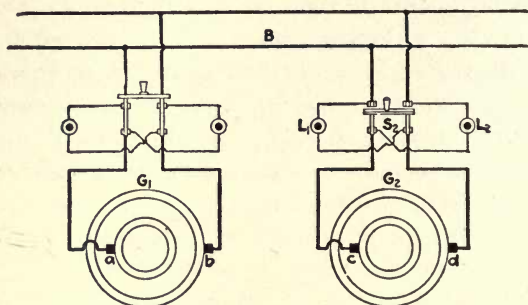

FIG. 419.—Connections for synchronizing two single-phase alternators; lamps bright.

The reason that the lamps in either method provide a guide is very simple. When terminal c of generator G_2 , Fig. 418, is positive at the same instant as terminal a of generator G_1 and the voltage of the two machines are of the same value, then there can be no flow of current from one machine to the other, since the voltage of one machine completely neutralizes the voltage of the other so far as a circuit through the two machines is concerned. Therefore lamps L_1 and L_2 will not light up, indicating that the two machines have the same polarity. However, if terminal c is positive when terminal a is negative, then current can flow from c around to a through the armature of G_1 to b back to d and through armature G_2 to c , thus completing the circuit. It is seen from this that the same conditions exist as would if two direct-current machines of opposite polarity were connected through lamps L_1 and L_2 ; double potential of one machine would be applied

across the lamps, and if they are for the voltage of one machine they will come up to full brilliancy, indicating, when connected as in Fig. 418, that the alternators have opposite polarity when the lamps are bright. In Fig. 419 if terminal c of G_2 is positive at the same instant as a of G_1 , and the voltage of both machines is the same, then the two machines are in synchronism. However, in this case current can flow from terminal c of G_2 through L_2 around to b through G_1 to a and back through L_1 to d and through G_2 to c . Consequently the lamps will burn bright when the machines are in synchronism.

Other Methods of Synchronizing.*—The earliest method used to determine the condition of synchronism was by connecting lamps in series between the machines, but is unsatisfactory because they can do nothing more than to indicate a difference in voltage above that value required to glow their filaments. Voltmeters have been substituted for lamps, but while they indicate any voltage difference, they do not show the relative speed of the machines or the phase angle between them. Only in the synchronoscope—synchronism indicator—are all these desirable features combined.

Whatever style of synchronoscope is used, the generator switch is closed when the synchronizing instrument's pointer is traveling slowly and is close to the zero. There are a number of makes of synchronoscopes, or synchronizers. The Lincoln synchronoscope, Fig. 420, is essentially a bipolar, split-phase, synchronous motor operating on the difference in phase between the machines being synchronized. Its two field coils, F and F' , are connected in series across one phase of the bus, on the running machine, consequently excited with alternating current instead of direct current. Its two armature coils, A and B , located at an angle of 90 deg. to each other, are connected in parallel through slip rings and brushes S to the corresponding phase of the incoming machine. The armature and field cores are of laminated iron.

*The remainder of this chapter appeared in *Power*, Sept. 16, 1919, under the title "Methods of Synchronizing Alternating-Current Machines," by Frank Gillooly.

the field circuit FF , causes the armature to assume the position where its lines of force coincide with those of the field. As this point changes the armature rotates with it. Since the

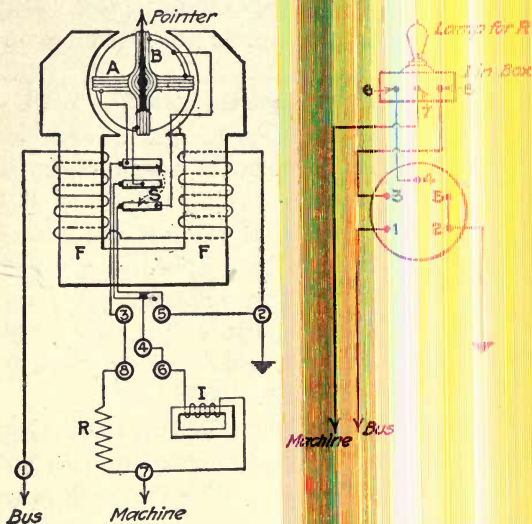

FIG. 420.—Schematic diagram of Lincoln synchronoscope.

current in the field coils lags the voltage across them by nearly 90 deg., and the current in the armature coil B , due to the inductance in series with it, lags the voltage across it by approximately 90 deg., at exact synchronism B will be in the position where its field will be parallel to the field of FF . This position of the armature at synchronism brings its pointer to the vertical position, as shown in Fig. 420, corresponding to the indication on a clock at the hour of twelve. The indicator rotates clockwise when the incoming machine is "fast" and counter-clockwise when the incoming machine is "slow."

Another type of synchroscope operating on the same principle is shown diagrammatically in Fig. 421. The moving element consists of two vanes, A and A , on either end of a cylindrical iron core in the center of the fixed coil C and fastened to the shaft carrying the pointer B . The rotating field is produced by the two stationary coils M and N situated 90 deg. apart and connected in parallel, M through a resistance R and N through an inductance I .

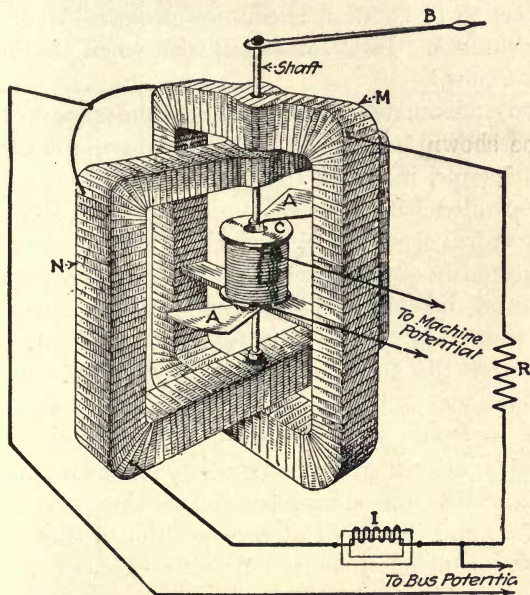

FIG. 421.—Synchroscope similar to Fig. 420, but with all coils stationary.

The vanes are excited alternately positively and negatively by the alternating field of coil C and are deflected by the fields of coils M and N . Coil M has its current in phase with that of C and deflects the vanes so as to parallel the field of M with that of C . Coil N , with the inductance I in series, has its current lagging that of C by approximately 90 deg.; and so long as this phase relationship is maintained—which is the point of synchronism—it exerts no torque on A and A . At any

other angle of phase between N and C , N will deflect the vanes; and with a difference in frequency between machine and bus a varying torque will be produced that will rotate the shaft.

In this instrument the rotating field is produced in the split-phase winding by the bus potential and the alternating field by the machine potential, an arrangement opposite to that of the Lincoln instrument, Fig. 420. Hence, the indicator's direction of rotation is counter-clockwise when the incoming machine is "fast" and clockwise when the incoming machine is "slow."

Electrodynamometer Type of Synchronoscope.—The synchronoscope shown in Fig. 422 operates on the electro-dynamometer principle, in which the torque exerted on a movable coil A , suspended between two stationary coils F and F' , is opposed by spiral control springs. The stationary coils F and F' are connected in series through the resistance R_F across the bus or running machine. The movable coil A , carrying the pointer, is connected in series with a condenser C and a resistance R_A , across the machine to be synchronized. A 90-deg. phase displacement is thus obtained by making the current in A lead that in F and F' by means of the condenser.

At exact synchronism—the true 90-deg. phase angle between the movable and stationary coil circuits—no torque is exerted on A , and it is held at zero position in the center of scale by the control springs. A difference in frequency between the machines will produce a varying torque, and A will oscillate the pointer back and forth on the scale. If the frequencies of machine and bus are equal but there is a difference in phase, A will take up a position of balance along the scale corresponding to this phase angle. Right and left of the zero, central, position of the scale are "fast" and "slow" respectively with regard to the machine. The pointer merely oscillates back and forth on the horizontal scale instead of rotating over a circular dial. The dial is illuminated by one lamp connected to the secondary S of a transformer having two primaries P and P' , connected, one across the incoming

machine and the other across the bus, and is bright at synchronism. Each revolution of the synchronoscope pointer represents one cycle difference in frequency between the alternators. The deflection of the pointer from zero at any instant represents the phase angle between the machines.

The synchronoscope is not intended to be kept energized when not in use or to be revolved at too great a speed. Where synchronizing lamps are provided, the speed of the alternator should be adjusted closely by them before the synchronoscope

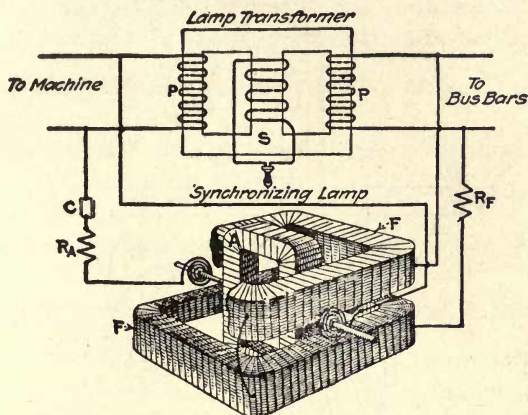

FIG. 422.—Synchronism indicator that operates on the electro-dynamometer principle.

is plugged in circuit; if necessary, the synchronism indicator may be plugged in for a moment in order to determine whether the incoming machine is fast or slow. Just as the lamps can be checked against the synchronoscope when synchronizing, so should the instrument be checked against the lamps when phasing out apparatus.

Synchronoscope Connections.—In Fig. 423 is shown a simple form of Lincoln synchronoscope installation that is frequently met with. The synchronizing bus runs to all generator panels. All receptacles are wired alike, to the same phase on each machine. One side of the generator potential transformers is grounded, the other sides are brought to the

bottom terminals T_1 and T_2 of the receptacles. Two kinds of plugs are used: One P_r , is inserted in the receptacle of the running machine, the other, P_s , in the receptacle of the incoming machine. The top connection, B_1 and B_2 , of each receptacle goes to conductor B of the synchronizing bus connected to the field coils of the synchronoscope. The third point of each receptacle, M_1 and M_2 , goes to the conductor M of the

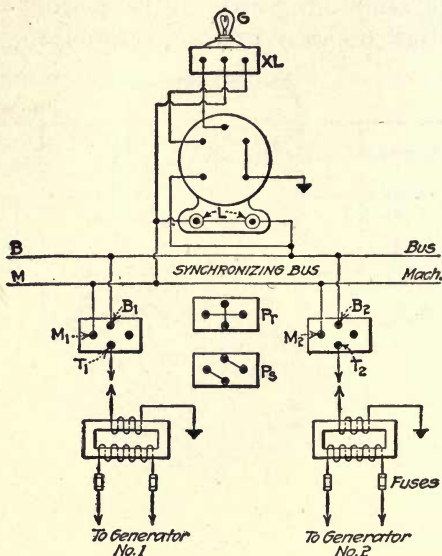

FIG. 423.—Diagram of connections for Lincoln synchronoscope.

bus connecting to the armature of the synchronoscope. The fourth terminal of the receptacle is not used with grounded secondary transformers. The inductance-resistance box is shown at XL , of which lamp G is the resistance. Lamps L are on the base of the synchronoscope and are connected so as to be dark at synchronism.

CHAPTER XXV

KILOWATTS, KILOVOLT-AMPERES AND POWER FACTOR.

How Current Builds up in a Direct-current Circuit.—

In a direct-current system, if a constant pressure of E volts is applied to a circuit having R ohms resistance, the current I , in amperes, that will flow in the circuit will equal $\frac{\text{volts}}{\text{ohms}}$ or

$I = \frac{E}{R}$ (Ohm's Law). For example, when a resistance of 1.5 ohms is connected across the terminals of a 105-volt direct-current generator, the current set up in the system is $I = \frac{E}{R}$

$= \frac{105}{1.5} = 70$ amperes, which is the value of the current after it has reached a steady flow. A fact frequently overlooked is that the current does not instantaneously attain a constant flow, but gradually increases to a normal value. This is illustrated in Fig. 424, where the current in amperes and the pressure in volts have been plotted on the vertical ordinate to the same scale and the time in fractions of a second along the horizontal. Starting at the point marked zero, which represents the closing of the circuit, the full pressure is instantly applied as shown by the line marked "volts." However, instead of the current at once reaching a normal value, it gradually increases, in the first tenth of a second reaching a value of 43 amperes, in two-tenths about 60 amperes, in three-tenths 65 amperes, and in one second approximately normal value, or 70 amperes. At this point the current curve becomes parallel with the voltage.

This gradual building up of the current is similar to start-

ing a machine with a heavy flywheel, during the period of acceleration of which energy is being stored up in the moving mass. Just as energy is stored in the moving mass, energy is also stored in an electric circuit. In the latter, however, the storing of energy while the current is increasing is due to the magnetic field set up by the current and is more pronounced in a circuit consisting of a coil of wire wound on an iron core than in a straight conductor or coil in open air. After the machine has been accelerated, if the source of driving power be removed, it will continue to keep in motion for a

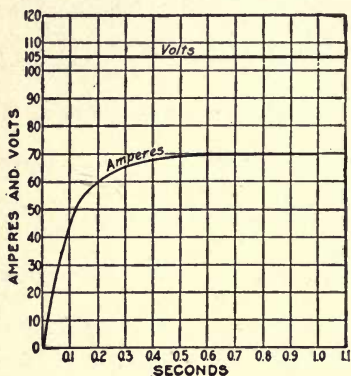

FIG. 424

FIG. 424.—Curves showing how current increases in a circuit.

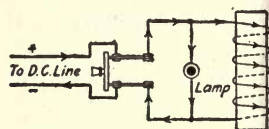

FIG. 425

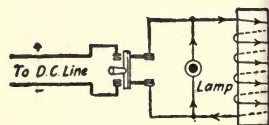

FIG. 426

FIGS. 425 and 426.—Illustrate effects of inductance due to opening and closing a circuit.

period, coming to rest gradually as it expends the stored energy in overcoming friction. Likewise, when an electric circuit is opened, the current does not come to rest instantly but gradually, as evidenced by the spark at the switch. This is always more marked when the current is heavy or where the circuit is a coil of wire wound on an iron core, such as, for example, the field coils of an electric machine. The field current, even in machines of considerable size, is comparatively small; but if this circuit is interrupted a severe spark occurs, and if the circuit is opened suddenly a very high voltage is produced, which is likely to break down the insulation

of the windings. Similarly, a machine with a heavy flywheel cannot be brought to rest suddenly without wrecking the machine. If an ordinary incandescent lamp be connected in parallel with a coil of wire wound on an iron core, such as a lamp connected across the field terminals of a generator, and the switch is closed to a source of an electric current, as in Fig. 425, a current will be set up in the system as indicated. After the current has reached normal value, if the switch be opened, the lamp will continue to burn for a short period, because of the energy stored in the magnetic field, although disconnected from the circuit. The direction of the current through the lamp and coil, after the switch is opened is indicated in Fig. 426. From this it is evident that the current does not suddenly come to rest, but has a tendency to keep in motion just as the machine did with the flywheel. Fig. 427,

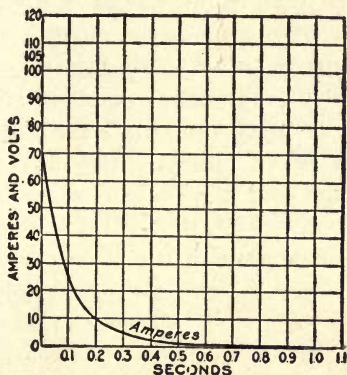

FIG. 427.—Curve showing how current decreases in a circuit.

illustrates what takes place in the circuit described in Fig. 424, when the source of electromotive force is removed; instead of the current coming to rest instantly, it gradually decreases as shown by the curve.

Lenz's Law.—The foregoing is evidence of what is called the law of inductance, first stated by Lenz and known as "Lenz's Law." Briefly stated, this is in part: "Whenever the value of an electric current is changed in a circuit, it

creates an electromotive force by virtue of the energy stored up in its magnetic field, which opposes the change," as explained in Chapter XII.

Current Lags Behind Voltage.—What has been shown in Figs. 424 to 427 is that the current lags behind the electromotive force, reaching its normal or zero value an instant later than the voltage. With direct current this occurs only upon opening and closing the switch or when the resistance of the circuit is changed, such as when devices are added or removed from the circuit; therefore it would not be expected to seriously affect the flow of the current. However, in an alternating-current circuit where the current is changing back and forth very rapidly, it might be expected that this property (inductance) would have some effect upon the flow of the current. This statement is borne out by referring to Fig. 424. Here it will be seen that if the circuit is allowed to remain closed for only $\frac{1}{10}$ of a second, the current would increase only to about 43 amperes before it would decrease again. Fig. 428 shows the effect of inductance in an alternating-current circuit. The full-line curve represents the impressed voltage whereas the dotted curve indicates the current that passes through its maximum and zero values an instant later than the electromotive force. At the point *b* the electromotive force is zero, but the current in the circuit is of considerable value and does not decrease to zero until point *c* is reached. Between these two points the electromotive-force curve is below the time line, while the current curve is above. This indicates that the current is flowing opposite to the voltage of the generator, which does not seem in accordance with the law governing the flow of current in a circuit.

Consider what takes place in an alternating-current circuit: In Fig. 429 a generator *G* is connected to a load *L*. Assume the electromotive force to be building up a polarity as shown. When it has reached a value indicated by *a* on the curves, Fig. 428, the current is zero; beyond this the current increases in value in the same direction as the electromotive force. This continues until the instant *b* on the curves is

reached; here the electromotive force of the generator has become zero, but not so with the current. When the current begins to decrease, it sets up in the circuit an electromotive force which tends to keep it flowing just as in the direct-current circuit. At the instant the voltage of the generator becomes zero, the electromotive force induced in the circuit is of a value and direction such as to keep the current flowing. Thus the conditions are reversed—the generator becomes the load and the load the generator. From points *b* to *c* on the curve the load sets up a current through the generator, as

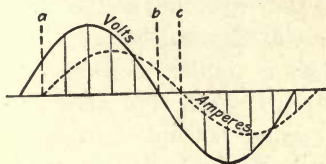

FIG. 428

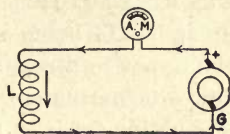

FIG. 429

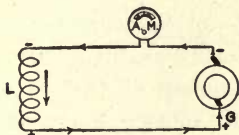

FIG. 430

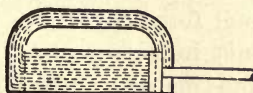

FIG. 431

FIGS. 428 to 431.—Illustrate a lagging current.

indicated in Fig. 430, just as the coil in Fig. 426 sets up a current through the lamp after the switch had been opened. Also, from points *b* to *c* the voltage due to inductance is decreasing while that of the generator is increasing in the opposite direction. At *c* the voltage of the generator has increased to a value equal and opposite to that due to the inductance, and the current becomes zero. Beyond this point the current reverses and again flows in the same direction as the generator electromotive force. This is what happens at each reversal of the current. The ammeter in the circuit, Figs. 429 and 430, not only reads the current that is flowing from the generator but also that flowing from the load to the generator. From this it is obvious that the ammeter reading

will be too high where inductance is present in the circuit, and this will be referred to later.

Pump Analogy of Alternating Current.—A physical analogy of the action of an alternating current in a circuit is given in a valveless pump, Fig. 431. If the piston be oscillated back and forth in the cylinder an alternating current of water will be produced in the system. The pressure applied to the piston not only has to overcome the resistance due to the friction of the water on the sides of the cylinder and pipe, but has also to overcome the inertia of the water, first in getting it started from rest at the beginning of the stroke, and again it has to bring it to rest at the end before it can start in the opposite direction. This is similar to what took place in the alternating-current circuit, Figs. 429 and 430. The electromotive force of the generator not only had to overcome the resistance of the circuit, but also the back pressure induced by the changing value of the current.

In the water analogy it would not be correct to say that the total force applied to the piston is useful in keeping the elements in motion. At the beginning of the stroke work had to be done in getting the mass in motion, and again at the end of the stroke in bringing the mass to rest; consequently the power supplied to the piston may be divided into two parts—a useful component overcoming the friction of the system and keeping the mass in motion, and another that is used in overcoming the inertia of the elements. This latter component might be considered as not doing any useful work, for at the end of the stroke it has to undo that which it did at the beginning.

In an alternating-current circuit, as the current increases in value it produces a back pressure in the circuit; therefore the total electromotive force produced by the generator is not effective in overcoming the ohmic resistance of the circuit, but part of it is used in overcoming the inductance. Similarly, on the latter half of the alternation as the electromotive force decreases to zero the current does not come to rest with it but sets up an electromotive force which tends to keep the current

flowing; consequently, the generator will have to apply pressure in the opposite direction to bring the current to rest. Hence it would not be proper to consider that the total pressure is useful in setting up a current in the circuit, but instead it is made up of two components—one a useful component, which overcomes the ohmic resistance of the circuit, and another component which overcomes the inductance.

Apparent Watts and Useful Watts.—In a direct-current system the volts multiplied by the amperes equals the watts transmitted in the circuit. This is also true in an alternating-current circuit where the current is in step with the electromotive force, as shown by the curves, Fig. 432. However,

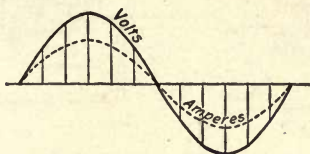

FIG. 432.—Curves of voltage and current in step.

such a condition is rarely true in practice, the current being usually more or less out of step with the volts. It has been shown that in an alternating-current circuit where inductance is present, the voltmeter and ammeter readings give too high a value for the effective volts and amperes, therefore the product of these two readings will give too high a value for the useful watts. For this reason the product of the volts multiplied by the amperes in an alternating-current circuit is called "apparent watts," or volt-amperes. A wattmeter will read the useful watts, or "true watts," transmitted irrespective of the relation between the currents and electromotive force.

A Wattmeter Reads True Watts.—Why a wattmeter will read the useful watts transmitted in the circuit will be evident by referring to Figs. 433 and 434. Assume the current and electromotive force to be building up a polarity as indicated in Fig. 433, the current having a direction through the wattmeter elements as shown by the arrowheads. While the cur-

rent is increasing, part of the energy is stored up in the magnetic field and is not available for doing useful work. Inasmuch as the wattmeter registers the product of the volts and amperes, it will therefore be registering too high a value for the useful watts on the first half of the alternation. As the current dies down in the circuit, the effect of inductance is to keep it flowing.

In the Figs. 428 to 430 it was shown that when the electromotive force of the generator decreased to zero the current did not, but for a period the load supplied current to the generator. The effect of this condition upon the wattmeter is

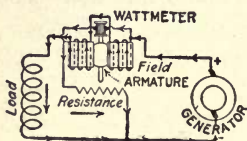

FIG. 433

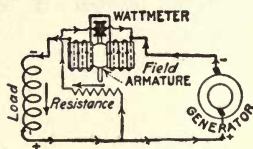

FIG. 434

FIGS. 433 and 434.—Watt-hour meter connected on single-phase circuit.

shown in Fig. 434, from which it will be seen that the current through the movable element is reversed from that in Fig. 433, but is still flowing in the same direction in the current coils. Reversing the current in one element only will reverse the torque of the instrument, that is, it will have a tendency to turn backward. The backward torque continues from points *b* to *c* on the curves, Fig. 428, which is just enough to offset the excess reading of the meter on the first half of the alternation, beyond point *c* the current builds up in the same direction as the electromotive force and the process is repeated.

Power in an Alternating-Current Circuit.—The product of volt multiplied by amperes (apparent watts) in an alternating-current circuit is usually called "volt-amperes," and is equivalent to the actual watts in a direct-current circuit. In direct-current work the number of kilowatts is expressed by the formula, $kw. = \frac{\text{watts}}{1,000}$. The term kilovolt-amperes

(kv.-a.) is used in alternating-current work and equals $\frac{\text{volt-amperes}}{1,000}$. It is general practice to rate all alternating-current generators, synchronous

motors, synchronous condensers and transformers in kilovolt-amperes instead of kilowatts. The ratio of the apparent watts to the true watts $\left(\frac{kw.}{kv.-a.}\right)$ is called the "power factor." By transposition four other formulas are obtained, namely:

Watts = volt-amperes \times power factor; volt-amperes = watts \div power factor; kilowatts = kilovolt-amperes \times power factor; and kilovolt-amperes = kilowatts \div power factor.

The following problems will illustrate the application of the foregoing formulas:

1. Find the power factor of a single-phase alternating-current circuit when the voltmeter indicates 450 volts, the ammeter 50 amperes and the wattmeter 20 kw.

$$\text{Volt-amperes} = 450 \times 50 = 22,500 \text{ (apparent watts).}$$

$$\text{Kilovolt-amperes} = \frac{\text{volt-amperes}}{1,000} = \frac{22,500}{1,000} = 22.5.$$

$$\text{Power factor} = \frac{\text{kilowatts}}{\text{kilovolt-amperes}} = \frac{20}{22.5} = 0.89.$$

(or 89 per cent)

2. What size of generator is required to supply a load of 35 kw. at 85 per cent power factor?

$$\text{Kilovolt-amperes} = \frac{\text{kilowatts}}{\text{power factor}} = \frac{35}{0.85} = 41.2.$$

The power factor is always less than one, except when the current is in step with the electromotive force. Under such a condition the true watts and apparent watts are equal, which condition is referred to as unity power factor. In the second problem one of the effects of low power factor is manifested, namely—the generator has to be of larger capacity to supply the load when the current is out of step with the electromotive force than when they are in phase; therefore it is desirable to keep the power factor as near unity as possible.

Effects of Capacity.—So far only inductance has been mentioned as affecting the relation of the current to the electromotive force. There is, however, another element present known as capacity, or in other words, the property of a condenser. The effect of capacity in an alternating-current circuit is the same as inductance only in the reverse order; that

is, inductance causes the current to lag behind the electromotive force, while capacity causes the current to flow ahead of the electromotive force.

Capacity has the same effect in a circuit as would be experienced if a chamber *C* with an elastic diaphragm across it were placed in the pipe line, Fig. 431. Fig 435 shows this arrangement. If the piston is pushed toward one end of the cylinder, the diaphragm will be distorted as indicated by the dotted line, to accommodate the water displaced from the cylinder. Distorting the diaphragm creates in it an effect against the motion of the piston, so that when the piston is reversed, the energy stored in the diaphragm will assist in reversing it.

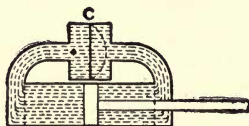

FIG. 435.—Hydraulic analogy of capacity (condenser effect) in an alternating-current circuit.

The energy stored in the diaphragm is opposite to that stored up in the moving mass due to inertia. If the mass did not possess inertia, or the energy stored in the mass were less than that stored in the diaphragm, the piston and water would reverse sooner than the force applied to keep it in motion. Capacity has a similar effect in an alternating-current circuit, by causing the current to reverse before the electromotive force, just as inductance prevented the current from changing its direction in the circuit until a very short interval after the electromotive force had changed its direction.

The relation between the current and electromotive force in a circuit where capacity only is present is represented in Fig. 436. Here it will be seen that the current passes through its zero and maximum values an instant earlier than the electromotive force and is said to lead the voltage. The power factor of such a circuit is called a leading power factor, while that of an inductive circuit is called a lagging power factor. In Fig. 435, if the pressure due to distorting the diaphragm

is equal to the inertia of the mass, the water and piston will move back and forth in time with the force applied. Similarly, in an alternating-current circuit, if the inductance and capacity are made equal, the current will flow in step with the electromotive force, as indicated in Fig. 432, and artificial means are frequently used to obtain this end.

Power-factor instruments have a scale similar to that shown in Fig. 437, unity power factor being indicated at the center. When the needle deflects to the right, it indicates a leading power factor; to the left, a lagging power factor. The power factor equals the cosine of the angle of lag or lead between the current and the electromotive force. Therefore the angle by which the current is out of step with the electro-

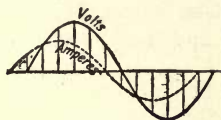

FIG. 436

FIG. 436.—Illustrating leading current.

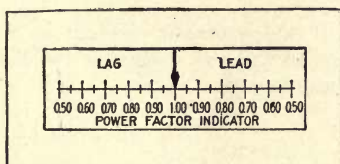

FIG. 437

FIG. 437.—Dial of power-factor indicator.

motive force may be found by taking the power-factor indicator reading; in a table of sines and cosines find an angle the cosine of which corresponds to this reading. For example, find the phase displacement between the current and the electromotive force if the power-factor meter indicates 0.85 on the lag side of the scale.

In the table of sines and cosines, Chapter XXI, it will be found that 0.85 corresponds approximately to the cosine of a 31-deg. angle. Hence this reading would indicate that the current lags 31 deg. behind the electromotive force.

From the foregoing it is obvious that if an alternating electromotive force be impressed upon a circuit, there are three elements which affect the flow of the current—the ohmic resistance, inductance and capacity—as compared with ohmic resistance only in a direct-current circuit. The inductance

and capacity in the circuit is called reactance, inductance being referred to as inductive reactance and capacity (or condenser effect) as capacity reactance. The combined effect of resistance, inductance and capacity is called the impedance of the circuit.

Power of Polyphase Circuits.—In the foregoing single-phase circuits only have been considered. If E is let to represent the volts and I the current per phase in a balanced two-phase circuit, that is, a circuit in which the volts and amperes of each phase are equal, the $Kv.-a. = \frac{2EI}{1,000}$; and in a balanced three-phase circuit $Kv.-a. = \frac{1.732EI}{1,000}$.

(1) If the voltmeter reading in a two-phase circuit is 2,300, the ammeter 50 and the wattmeter 180 kilowatts, find the kilovolt-amperes and power factor.

$$Kv.-a. = \frac{2EI}{1,000} = \frac{2 \times 2,300 \times 50}{1,000} = 230 \text{ kilovolt-amperes,}$$

and the power factor

$$P. F. = \frac{kw.}{kv.-a.} = \frac{180}{230} = 0.78.$$

(2) The voltmeter reads 6,600, the ammeter 15, and the power factor meter 0.85 on a two-phase circuit; find the kilowatt load.

$$Kv.-a. = \frac{2EI}{1,000} = \frac{2 \times 6,600 \times 15}{1,000} = 198 \text{ kilovolt-amperes.}$$

$$Kw. = kv.-a. \times P. F. = 198 \times 0.85 = 166.3 \text{ kilowatts;}$$

the wattmeter reading.

(3) In a three-phase circuit the wattmeter reads 250 kilowatts, the ammeter reading is 350 and the voltmeter indicates 550 volts, find the power factor.

$$Kv.-a. = \frac{1.732EI}{1,000} = \frac{1.732 \times 550 \times 350}{1,000} = 333.4 \text{ kilovolt-amperes.}$$

$$P. F. = \frac{kw.}{kv.-a.} = \frac{250}{333.4} = 0.72.$$

(4) When the voltmeter in a three-phase circuit reads 2,300 the ammeter 135 and the power factor meter 0.90, what should the wattmeter head?

$$Kv.-a. = \frac{1.732EI}{1,000} = \frac{1.732 \times 2,300 \times 135}{1,000} = 957.8 \text{ kilovolt-amperes.}$$

$$Kw. = kv.-a. \times P. F. = 957.8 \times 0.90 = 862 \text{ kilowatts.}$$

Where the load is unbalanced on a polyphase circuit take the average current of the different phases and use this average value the same as the ammeter reading on a balanced circuit, and this will give very close to the correct results in most cases for obtaining the kilowatt-amperes, etc.

CHAPTER XXVI

POTENTIAL AND CURRENT TRANSFORMERS.

Potential Transformer Operation.—The current required to transmit a given amount of power decreases as the voltage is increased. It was shown in Chapter XIX that if the voltage was doubled the current would be one-half, and the size of the conductor required to transmit a given load need only be one-quarter the size, to carry the current at the higher voltage as at the lower voltage with the same percentage loss in the line. This fact is taken advantage of in alternating-current circuits, and by the use of potential transformers the voltage is stepped up to a high value when power is to be transmitted long distances, and then stepped down to the required voltage at the load. Alternating current is generally generated at 440, 550, 2,300, 6,600, 11,000 or 13,200 volts. When a higher voltage is required it is usually obtained through transformers, since it is difficult to insulate rotating machines for a higher voltage than that given in the foregoing. Since all the parts of a transformer are stationary they may be thoroughly insulated and placed in a tank of oil which also assists in insulating the windings, as well as acting as a medium to transmit the heat away from the coils. Oil insulated transformers have been designed to operate on circuits up to 220,000 volts.

Types of Potential Transformers.—Transformers are designed in three general types, according to the method of cooling. (1) Oil-insulated and oil-cooled. In this type the coils and core are placed in a tank of oil, and the circulation of the oil due to heating is relied upon to transmit the heat from the windings and core to the surface of the tank. (2) Oil-insulated and water-cooled. With this type the coils and

core are immersed in a tank of oil as in the oil-cooled type, but the tank is made high enough to allow the placing of coils of pipe in the oil at the top of the tank, through which water is circulated to cool the oil. (3) Air cooled. In this type the windings and core are mounted in an iron case without a bottom; the unit set over a duct and a blower used to blow air up through the winding, which is discharged at the top of the case. In this way the heat of the winding and core is dissipated.

Principles of Transformer Operation.—The principle upon which transformers operate is known as mutual inductance and was explained in Fig. 187, Chapter XII. Here it was shown that if a conductor was in the magnetic field of another conductor carrying a current that was changing in value, the first conductor would have a voltage induced in it opposite to that applied to the conductor carrying the current.

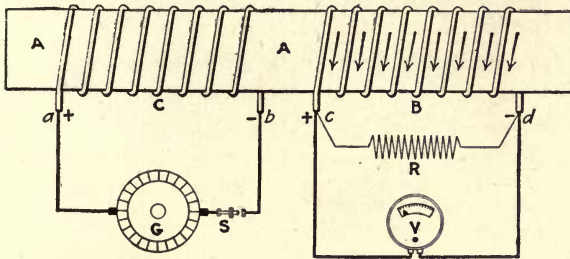

FIG. 438.—Two coils on iron core.

This principle is enlarged upon in Fig. 438; here two coils *B* and *C* are wound on an iron core *A*. Coil *C* is connected to a source of direct current and at the moment the switch *S* is closed, a current flows through coil *C*, causing *A* to become a magnet. The magnetic field thus introduced into *B* generates a voltage in it that can be read on voltmeter *V*. This voltage lasts only for the instant occupied to build up the field in *A*; as the field reaches its final value and stops increasing, the voltage at *V* drops to zero again. When the switch *S* is opened and the field in *A* collapses, a voltage is again momentarily generated in *B*. The reason for this can be explained

by reference to Fig. 439, which shows a longitudinal section of the coils and core. The magnetic field may be represented by the broken lines. It will be seen that they form loops, as at *L*. When the field begins to build up, these loops, beginning at nothing, expand and in so doing cut across all the wires *W* and *X*. We know that when a magnetic flux cuts across a conductor a voltage is generated in the latter, hence the voltage registered by *V* in Fig. 438. Again, when the field is reduced to zero, as by the opening of switch *S*, the loops of the field in Fig. 439 contract, and consequently cut across the conductors *W* and *X*, as before, but in the opposite direc-

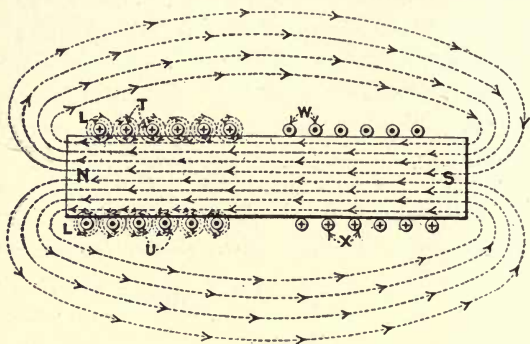

FIG. 439.—Section through coils and core, in Fig. 438.

tion. Hence, the voltage that appears across the terminals of *B* when the current through *C* in Fig. 438 is broken. Since the lines of force, when contracting, cut the conductors in the opposite direction to that in which they cut them when expanding, it is to be expected that the voltage registered by *V* when the switch *S* is opened is opposite to that which it registers when the switch is closed, and such is the case. Moreover, it will be found that the direction of the voltage in *B* is opposite to that in *C* when the coils are wound in the same direction as they are in Fig. 438. Thus, when *a* is plus and *b* minus, we find that *c* is also plus and *d* minus.

Since a voltage is created across coil *B*, Fig. 438, it is evident that current would flow through a circuit if connected

to it. If the switch S were to be continuously closed and opened with great rapidity, a pulsating voltage would be established across coil B that would cause a pulsating current to flow through whatever circuit was connected to it. It is therefore apparent that energy from generator G can be transferred to the resistance R , in spite of the fact that no electrical connection exists between the generator and the resistance. For the continual make and break of switch S we can substitute an alternating current. By its use the current through C will continually be made to alternate back and forth, so that the effect is much like that obtained by means of the switch S . With an alternating current large values

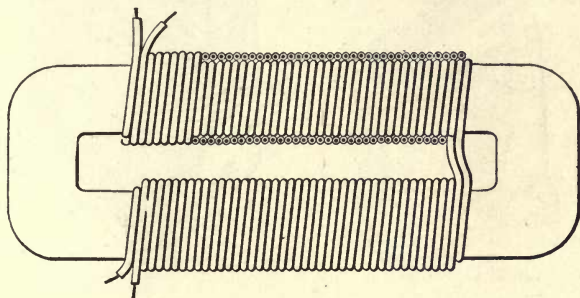

FIG. 440.—Two coils one wound over the other on an iron core.

can be handled with entirely satisfactory results, and the device is known as a transformer. In practice the core A is extended and bent around to form a complete loop of iron as in Fig. 440 and the coils wound on both legs of the core. Moreover, it has been found that better operating results are obtained when one coil is wound over the other, instead of side by side. The result is that in actual transformer construction the coils would be placed somewhat as illustrated in Fig. 440.

Core-type and Shell-type Transformers.—There are two types of transformers according to the way the coils and core are arranged; namely, the core-type and the shell-type. In the core-type the coils are placed on the core as in Fig. 441 where in the shell-type the core is built up around the coils in Fig. 442. For low and medium voltages either type may be

used, but for very high voltages most all transformers are of the core type.

The iron core is not made of a single piece of solid iron bent into shape, as indicated in Fig. 440, but is built up of many pieces of sheet iron that are stamped to the shape of the core, as that illustrated in Fig. 443. The object of this is to reduce to as small a value as possible the currents that are induced in the core, known as eddy currents. Consider a

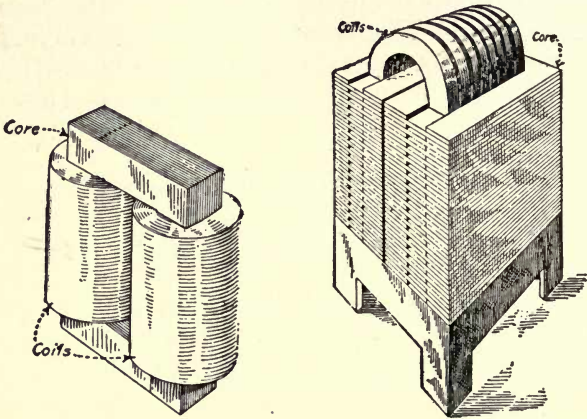

FIG. 441

FIG. 442

FIG. 441.—Core-type transformer.

FIG. 442.—Shell-type transformer.

solid core with a hole H in it, as in Fig. 444. The core comprises a complete circuit, as indicated by the arrows. It is therefore equivalent to a conductor making a single turn, whose ends are joined. Therefore, if an alternating current flows in coil C , Fig. 444, it will induce a voltage in the core A , the same as in a turn of any other conductor. Since this single turn is closed upon itself, a current would flow through it. The hole H in Fig. 444 may be imagined to be made smaller and smaller, until it closed and made a solid core; however, the eddy currents would still circulate. If the core is built up of sheets of iron, as in Fig. 443, it is evident that the eddy currents in circulating around in the core must cross

from one sheet to another. The resistance introduced in the path of the current by the slight air space that may be between the sheets and by the thin coating of scale on their surfaces, is sufficient to restrict the flow of current to comparatively small values, whereas the solid core will allow them to assume

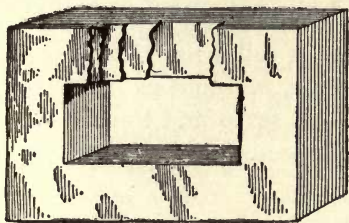

FIG. 443

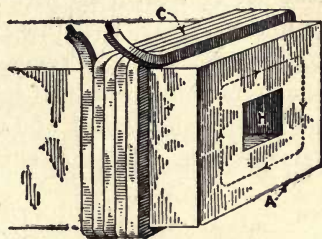

FIG. 444

FIG. 443.—Shows construction of transformer core.

FIG. 444.—Shows how eddy currents are induced in transformer core.

values that involve large losses. For simplicity of construction, the individual sheets of iron are not punched out as a complete loop, as in Fig. 443, but in one type of construction they are made in two pieces and assembled in two parts, as in Fig. 445. The coils—which are wound on forms—can then

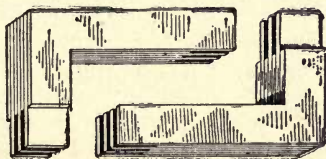

FIG. 445.—Transformer core in two sections.

readily be slipped over the two parts of the core, which are then placed together to form a complete circuit of iron. The appearance of a core and its coils is shown in Fig. 441.

Relation of Primary and Secondary Volts.—The voltage induced in coil *S* of Fig. 446 when coil *P* is connected to a source of alternating current, is proportional to the number of turns in the coil. This must be so, since the voltage in *S* is induced by the lines of force which cut across its turns as

the lines expand outward and collapse with each alternation of the current in P . It is evident that the magnetic flux will induce the same voltage in each turn of the conductor it cuts, and since the total voltage of the coil is the sum of the voltages induced in its turns, it follows that the greater the number of turns, the greater must be the voltage of the coil, and vice versa. It is this fact which makes it possible to step up and step down voltages. Thus, if coil S has 100 turns and the voltage induced in it is 220 volts, we could get 2,200 volts by substituting a coil of 1,000 turns for S and leaving P the same as it is. Not only is the voltage of S proportional to the

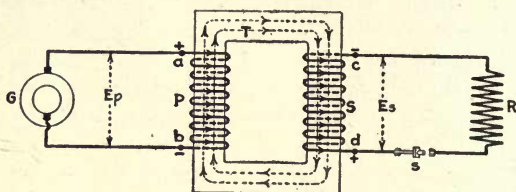

FIG. 446.—Schematic diagram of potential transformer.

turns in it, but its voltage and that applied to P are in the ratio of the turns in S and P . Thus, if P has 12,000 turns and S has 200, and 6,600 volts if applied to P , the voltage across S will be 110 volts, because, *volts S* : *volts P* :: 200 : 12,000, or

$$\text{volts } S = \frac{\text{volts } P \times 200}{12,000} = \frac{6,600 \times 200}{12,000} = 110 \text{ volts.}$$

This is readily explainable since the voltage applied to P caused a certain current to flow through it. This current creates a magnetic flux which will produce in every turn of S the same voltage as exists across each turn of P .

The winding to which the source of current is applied is called the primary of the transformer. The winding in which a voltage is induced is called the secondary. If the secondary voltage is higher than the primary, the transformer is referred to as a step-up transformer; if the secondary voltage is lower than that of the primary, it is a step-down transformer. Whether it be one or the other, we have the relation, *second-*

ary voltage : primary voltage :: secondary turns : primary turns. If we substitute the quantities by symbols we have, $E_s : E_p = T_s : T_p$, where E stands for voltage and T for turns.

We now come to that property of transformers, the possession of which makes possible their use for power-transmission purposes, which is, that the current taken by the primary is automatically controlled by the load that is connected across the secondary. In Fig. 466, P is the primary and S the secondary windings of a transformer.

How the primary current responds to the secondary load and adjusts itself to the value of the latter may be explained as follows:

The moment current begins to flow through S , the flux in the core T will be affected by it. The magnetomotive force set up by the current through S will always be in opposition to that created by the current through P . For example, if at a given instant, a is positive and b negative, the current through P will be in the direction of the arrows, making the direction of the flux that indicated by the arrowheads on the broken lines representing the lines of force. The voltage induced in S will consequently be in the direction of the arrows on winding S , and the flow of the current will therefore also be in that direction if switch S is closed. The magnetomotive force set up by this current will tend to set up a flux through coil S , and hence will be opposed to that due to P . The result is that the reactance of P is lowered, since all reactance is due to the flux continually cutting back and forth across the conductors of which the reactance is composed. As soon as the reactance is thus reduced the current through P increases, until the flux through T is again the same as before. When the current in S is reduced by a change in its load, less flux is developed by it, so that there is less flux to oppose that of P . This causes the flux through T to increase, thereby increasing the reactance of P and consequently throttling the current through it to the point where the flux through T again becomes normal.

Grouping of Transformers.—Transformers may be con-

nected in series or parallel just as batteries are connected in series or parallel. When so connected they are operated on a single-phase circuit. For two-phase operation two transformers are used, one on each phase, and can be used separately for four-wire operation as in Fig. 386, or the two adjacent terminals may be connected together, as in Fig. 387, Chapter XXIII, for three-wire operation. Three transformers may be grouped in delta by connecting the primaries and secondaries as in Fig. 404, or grouped in star by connecting the primary and secondary windings as in Fig. 405, Chapter XXIII.

Current Transformers.—Where large currents are to be measured on alternating-current circuits, or where the current is measured on high-voltage circuits, the instruments are connected into the circuit through a current transformer. This type of transformer is similar in its operation to the potential transformer but instead of being connected directly across the line as is the voltage transformer, the current transformer is connected in series in one leg of the circuit as in Fig. 447.

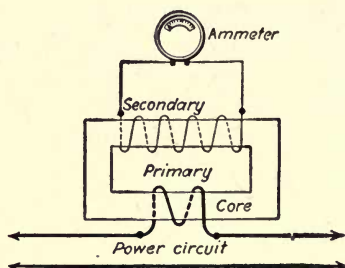

FIG. 447.—Schematic diagram of current transformers.

Current transformers are also used to connect protective devices into the circuit, etc. Since the current transformer is connected in series in the circuit the volts induced in its secondary depends upon the load on the line. If there is no load on the circuit then the volts in the secondary is zero. The transformer is so designed that the secondary voltage under all normal conditions is very low.

Standard practice is to design all current transformers so that 5 amperes will be flowing in the secondary circuit with full load on the primary, consequently, most alternating-current instruments and protective devices are designed for 5 amperes in their current coils. For example, a current transformer designed for 1,000 amperes in its primary would only supply 5 amperes to an ammeter connected to its secondary, when 1,000 amperes were flowing in the primary. However, most switchboard ammeters are calibrated to indicate the primary current. Such a transformer as referred to in the foregoing would have a ratio of 1,000 : 5 or 200 : 1. The secondaries of a current transformer should never be left open-circuited. Before they are disconnected from the instrument or protective device the secondary should be short-circuited. If this is not done, when there is a load on the primary the voltage in the secondary will be built up to a very high value, which may break down the transformer's insulation, or the transformer may overheat due to the high iron losses in the core.

CHAPTER XXVII

ALTERNATING-CURRENT MOTORS

Parts of an Induction Motor.—Induction motors are made up of two major parts, the stator and the rotor. The stator, shown in Fig. 448, is the stationary element and has placed in slots, in the inner periphery of the core, coils which are grouped into a winding connected to the power circuit.

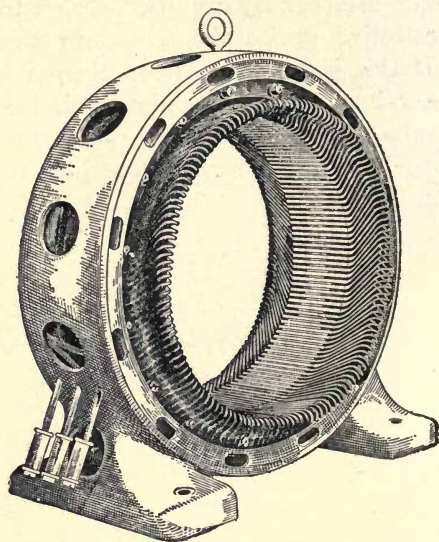

FIG. 448.—Induction-motor stator.

The rotor, Fig. 449, of the squirrel-cage type is built up of a laminated iron core, slotted on its outer periphery. In these slots are placed copper bars which are connected to rings at each end of the core, thus forming a closed winding, as shown. In the wound-rotor type the revolving element is wound with an insulated winding and connected to slip rings, Fig. 450,

similar to the winding used on a revolving-armature-type alternator. The slip rings are connected to an external resistance used for starting and to control the speed of the motor. The stator winding is the same for both types of machine.

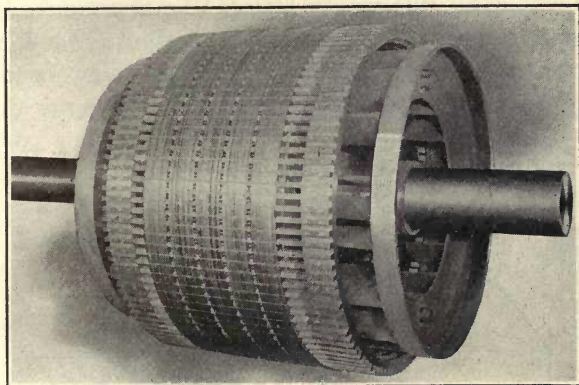

FIG. 449.—Squirrel-cage rotor.

The induction motor is differentiated from the direct-current motor in that where the latter is supplied with current from an outside source to both its armature and field windings,

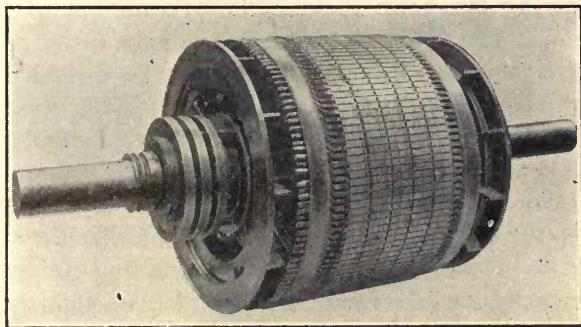

FIG. 450.—Phase-wound rotor.

in the induction motor the current is supplied to its stator winding only. Then how does the induction motor operate? is the question that naturally arises. This might be answered by saying, "On the same fundamental principles as the direct-

current motor''; namely, the reaction between the magnetic field set up about the conductors on the revolving element due to the current flowing in them and the flux from the polepieces, the polepieces in the induction motor being the stator. The fundamental difference between the two machines is in how the current is set up in the rotor winding of the induction motor, which has no electrical connection whatever with the stator winding. In the stator of an induction motor the magnetic field is made to revolve and this in turn reacts upon the current induced in the rotor bars and carries the latter around with the former.

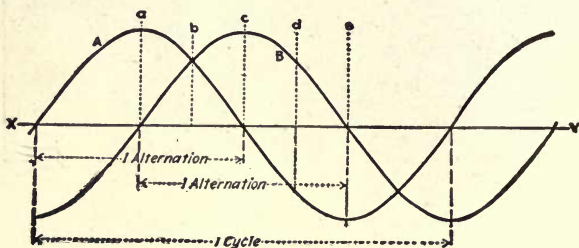

FIG. 451.—Two-phase voltage or current curves.

Revolving Magnetic Field.—The explanation of the revolving magnetic field can in general be most easily given by utilizing a two-phase circuit, the conditions of which may be represented by the curves *A* and *B*, Fig. 451. Instead of using a smooth-bore stator with a uniformly distributed winding, a field structure will be employed similar to that used in a direct-current machine (see Figs. 452 to 460). In this structure there are eight polepieces, four of which are linked together by the winding *A* and four by winding *B*, representing the conditions in a two-phase motor. Although there are eight polepieces, it will be seen in the following that the magnetic lines combine in such a way as to form but four poles. In this discussion it will be assumed that the current is in step with the voltage, although this is not true in practice; it nevertheless has no effect upon the production of the rotating magnetic field.

Consider the windings *A* and *B*, Fig. 452, connected to a two-phase circuit, and let curves *A* and *B*, Fig. 451, represent the voltage applied to the windings, consequently the current flowing in them. At the instant *a* on the curves, Fig. 451, it will be seen that the voltage in phase *A* is at a maximum value, while that in *B* is at zero, consequently the current in winding *A*, Fig. 452, will be at a maximum value. If the current is considered flowing in winding *A* in the direction of the arrowheads, poles A_1 to A_4 will be magnetized of a polarity as

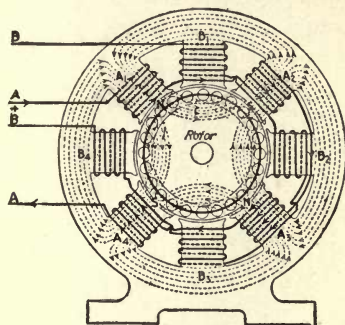

FIG. 452

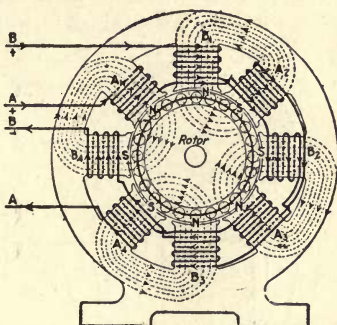

FIG. 453

FIG. 452.—Schematic diagram of two-phase motor.

FIG. 453.—Same as Fig. 452, but 45 degrees later.

indicated. Since the current is at a maximum, the magnetic field will also be at a maximum value and will divide at the center of the N poles, pass into the rotor core back into the S poles, as illustrated in the figure. This division of flux at the pole faces is similar to that in the bar magnet, Fig. 454. Here the flux also divides at the center of the N pole and passes around through the air to the S pole.

Next consider the condition in the circuit represented by the instant *b* on the curves, Fig. 451. At this instant the current in *A* has decreased and that in *B* increased until it is the same value in both. Applying this condition to the motor windings, the current will be about 0.7 maximum in each and in the same direction as in Fig. 453. This arranges the eight poles into four groups, each containing two like poles. Like

poles repel, therefore all the flux from any N pole will pass into the rotor core and go to the adjacent S pole, as shown in Fig. 453. This condition is illustrated with bar magnets in Fig. 455. Here the two similar magnets *A* and *B* are placed so that their like poles are adjacent to each other, and since like poles repel, the flux from one N pole will be pushed away from that of the other, consequently giving a distribution to the lines of force similar to that shown in the figure. Com-

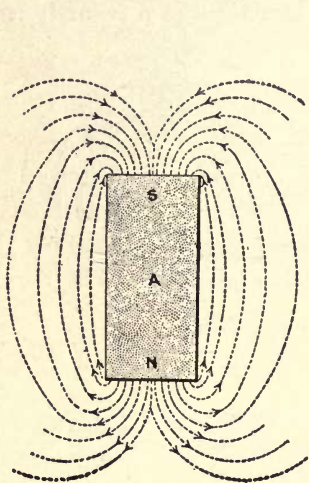

FIG. 454

FIG. 454.—Shows magnetic conditions in Fig. 452.

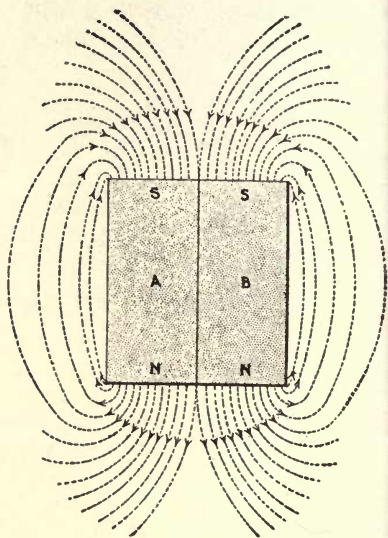

FIG. 455

FIG. 455.—Shows magnetic conditions in Fig. 453.

paring Figs. 452 and 454 with Figs. 453 and 455, it will be seen that where the centers of the magnetic fields are at the centers of *A* polepieces in Figs. 452 and 454, the centers of the magnetic fields are located between *A* and *B* polepieces in Figs. 453 and 455. In other words, the center of the magnetic field has been caused to move one-half the width of a polepiece.

At the instant *c*, Fig. 451, the current in phase *A* has decreased to zero, and that in phase *B* has increased to a maxi-

imum value, consequently the current in the motor's winding *A* will be at zero value, while that in winding *B* will be at a maximum value. This condition is illustrated in Fig. 456. The flux in the *A* polepieces has become zero, while that in polepiece *B* has reached a maximum value, and the center of the magnetic field is at the center of the *B* polepieces. This condition is the same as if bar magnet *A*, Fig. 455, was removed. Then the flux distribution would be as indicated in Fig. 458, which shows the center of the magnetic field shifted to the left from between *A* and *B* magnets, in Fig. 455, to the center of the *B* magnet, Fig. 458. Again, the center of the

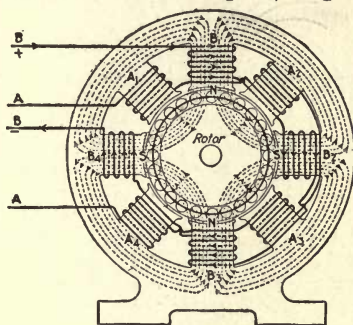

FIG. 456

FIG. 456.—Same as Fig. 452, but 90 degrees later.

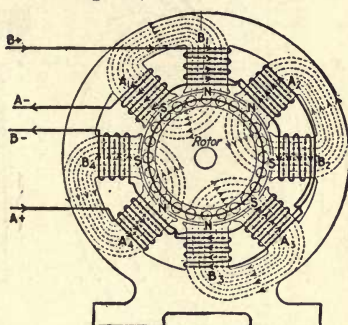

FIG. 457

FIG. 457.—Same as Fig. 452, but 135 degrees later.

magnetic field has been caused to shift one-half the width of a polepiece.

Returning to the curves *A* and *B*, Fig. 451, and considering instant *d*, it is found that the currents in *A* and *B* phases are again of the same value. But curve *A* is below the line *XY*, indicating that the current in phase *A* is flowing in an opposite direction to that in phase *B*. This condition is illustrated in Fig. 457. Here it will be seen that the direction of the current in winding *A* is reversed from that shown in Figs. 452 and 453, but the current in *B* is in the same direction as in Figs. 453 and 456. This has reversed the polarity of the *A* polepieces, and now the poles of *A* phase that had N polarity in Fig. 452 have become S poles in Fig. 457 and vice versa.

However, this has again brought like poles adjacent, and the flux distribution will be as shown. This is a condition similar to what would have been the case if magnet *A*, Fig. 455, had been taken from the left-hand side of the *B* magnet and placed on the right-hand side as in Fig. 459. Again the center of the magnetic field has shifted, this time from the center of the *B* polepiece to between *B* and *A* polepieces.

At instant *e* on the curves, Fig. 451, the current in phase *B*

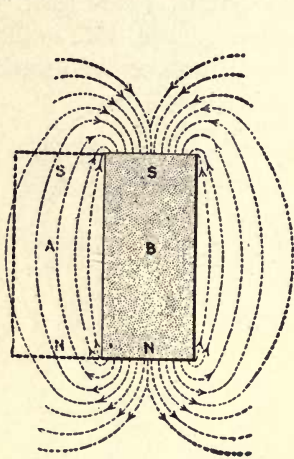

FIG. 458

FIG. 458.—Shows magnetic conditions in Fig. 456.

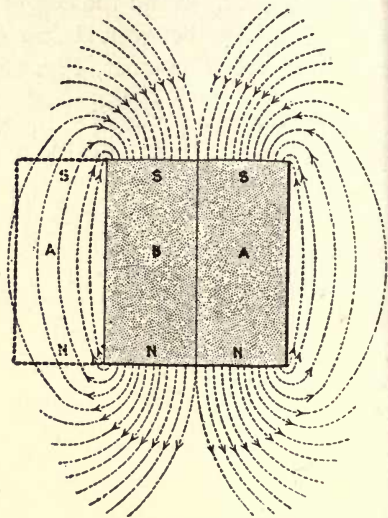

FIG. 459

FIG. 459.—Shows magnetic conditions in Fig. 457.

has decreased to zero, and that in phase *A* has reached a maximum value. This is a condition similar to that existing at instant *a*, excepting that the direction of the current in phase *A* is reversed. Consequently, the current in the motor winding will be zero in phase *B* and at a maximum value in phase *A*, as in Fig. 452, therefore the magnetism in pole *A* will be at a maximum and in *B* zero value, Fig. 460. This will give a flux distribution the same as that in Fig. 452, but of a reverse polarity. The center of the magnetic poles has now shifted

from between the *B* and *A* poles, Fig. 457, to the center of the *A* poles as shown in Fig. 460. A similar condition would be obtained in Fig. 459 if magnet *B* is removed as in Fig. 461. There the center of the magnetic field has shifted from between the *B* and *A* magnets to the center of magnet *A*.

Comparing Fig. 454 with Fig. 461, it is seen that the center of the magnetic field has shifted from the center of magnet *A*, Fig. 454, shown in dotted lines in Fig. 461, to the center of magnet *A*, shown in full lines, Fig. 461. Similarly in Figs.

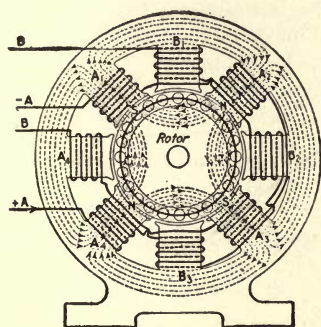

FIG. 460

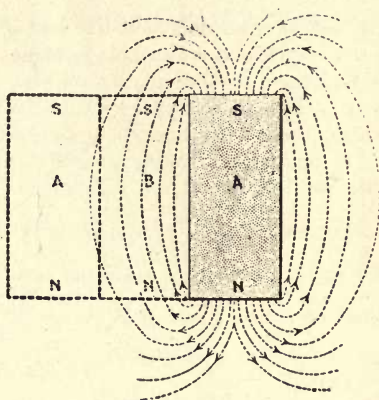

FIG. 461

FIG. 460.—Same as Fig. 452, but 180 degrees later.

FIG. 461.—Shows magnetic conditions in Fig. 460.

452 to 460, the magnetic field has shifted from the center of magnets *A*₁ and *A*₃, maximum value N poles, to the center of *A*₂ and *A*₄, maximum N poles; likewise the S poles have shifted from *A*₂ and *A*₄ to *A*₁ and *A*₃.

Relation Between Poles, Frequency and Speed.—Referring to the curve, Fig. 451, it will be seen that the current in each phase has passed through the equivalent of one alternation. At *a* the current in phase *A* is at a maximum, and that in phase *B* is at zero value; likewise at *e* phase *A* is again at a maximum value, but in this case in the opposite direction, and phase *B* is at zero.

From the foregoing it is evident that for one alternation the magnetic field in the motor shifts one pole, then for one cycle (two alternations) the magnetic field will shift two pole spaces. In other words, for each cycle that the current passes through, the magnetic field will shift around one pair of stator poles. Now, if the motor was connected to a 60-cycle circuit—that is, a circuit in which the current makes 60 complete reversals per second, or 120 alternations per second—the number of revolutions made by the magnetic field in one second would equal the cycles divided by the pairs of poles. In our problem the induction motor has four poles, or two pairs, therefore the speed per second of the magnetic field for a 60-cycle circuit will be $\frac{60}{2} = 30$ revolutions. Looking at this problem

another way, for one cycle the field will shift two pole spaces; therefore, for two cycles, in a four-pole machine, the field will shift four pole spaces or make one revolution; that is, two cycles is equivalent to one revolution. Then for 60 cycles the field will make $60 \div 2 = 30$ revolutions, which checks with the value obtained in the foregoing.

In one minute the speed will be 60 times that for one second, or in this case, $30 \times 60 = 1,800$ revolutions per minute. If S equals the revolutions per minute, $\frac{P}{2}$ the number of pairs of poles, and f the frequency,

the cycles per second, then the revolutions per minute S —that is, the speed of the magnetic field—is $S = \frac{120f}{P}$. Substituting the value 60 for the frequency (cycles per second) and 4 the number of poles gives

$S = \frac{120 \times 60}{4} = 1,800$. If the frequency were only 25 cycles per second,

$S = \frac{120 \times 25}{4} = 750$ revolutions per minute. From this it will be seen

that if a 4-pole motor is connected to a 60-cycle circuit, its magnetic field will revolve at 1,800 revolutions per minute, and on a 25-cycle circuit, 750 revolutions per minute.

The formula may be transposed to read $P = \frac{120f}{S}$ to find the number

of poles when the speed and frequency are known, and $f = \frac{PS}{120}$ to determine the frequency (cycles per second) when the number of poles and speed are known.

If the frequency equals 60 cycles per second and the speed 1,800 r.p.m., then $P = \frac{120 \times 60}{1,800} = 4$ poles. This is what it should be for the machine in the figures.

On the other hand, knowing the number of poles to be 4 and the speed to be 1,800 r.p.m., frequency $f = \frac{4 \times 1,800}{120} = 60$

cycles per second. From this it is evident that there is a fixed relation between the number of poles and the speed of the revolving magnetic field of an induction motor and the frequency of the circuits to which it is connected.

How Rotation is Produced.—In the foregoing the magnetic field was shown to revolve in a clockwise direction. Starting with this assumption, consider the action of the field on the rotor, to produce rotation. Assume the rotor to be at standstill in Fig. 462, as at the instant of starting, and with the magnetic field revolving in a clockwise direction. The lines of force will be cut in a counter-clockwise direction.

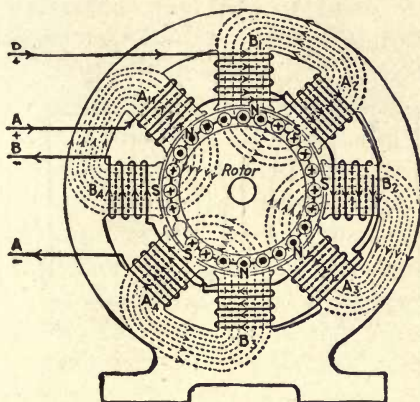

FIG. 462.—Shows direction of the current in an induction-motor's rotor conductors.

This condition is the same as though the magnetic field was stationary and the rotor was revolved in a counter-clockwise direction. This will be made clear by referring to Figs. 463 and 464. In Fig. 463 assume conductor *A* to be stationary and the magnetic field moved horizontally in a right-hand direction, as indicated by arrow *B*. Then the magnetic field would be cut by *A* from right to left. This would be the same as if the magnetic field were held stationary and the conductor moved horizontally to the left, as shown by arrow *B*, Fig. 464. When the conductors are cutting the lines of force in a counter-clockwise direction, Fig. 462, those under the N poles

will have a voltage induced in them that will cause a current to flow toward the reader, as indicated by the dots on the end of the conductor. The conductors under the S poles will have voltage generated in them that will cause current to flow down through the plane of the paper, as indicated by the crosses on the end of the conductors. Considering the action of the current in the rotor conductors on the magnetic field from the polepieces will show that it produces a turning effort in a clockwise direction; in other words the rotor in an induction motor turns in the same direction as the magnetic field revolves.

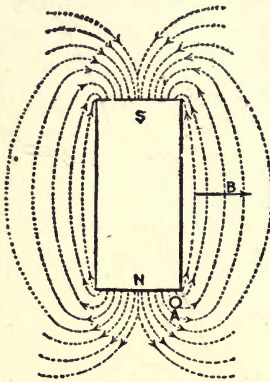

FIG. 463

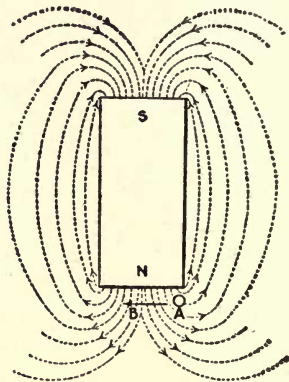

FIG. 464

Figs. 463 and 464.—Conductor in magnetic field.

At the instant of starting the rotor is at a standstill and the magnetic field is revolving by the rotor conductor at a speed, as was shown in the foregoing, which equals 120 times the frequency divided by the number of poles, or, for a four-pole machine on a 60-cycle circuit, equals $120 \times 60 \div 4 = 1,800$ revolutions per minute. This gives the maximum rate of cutting the lines of force, and consequently generates a maximum voltage in the rotor conductors of a frequency equal to the voltage applied to the stator.

Why the frequency of the rotor current will be the same as that of the stator current will be understood when it is

remembered that the polarity of the field coils changed with each alternation; therefore if the polarity of the field coils changed with each alternation, the voltage generated in the conductors under the polepieces will change with each alternation.

Rotor Must Run Slower than the Magnetic Field.—

Assume that the magnetic field is rotating at 1,800 r.p.m. and that power is applied to the rotor and caused to also run at 1,800 r.p.m. in the same direction as the magnetic field. Under such a condition the rotor conductors and the magnetic field would be running at the same speed, therefore the former would not be cutting any lines of force, consequently the voltage in the conductors would be zero and no current would flow in them. From the foregoing it is evident that when the rotor of an induction motor is at a standstill the voltage and frequency are at a maximum, but that as the rotor comes up to speed, the voltage and frequency of the rotor current decrease until when the rotor is running at the same speed as the magnetic field, the voltage and frequency become zero. Since no current flows in the rotor conductors when they are moving at the same speed as the magnetic field of the stator, no torque, turning effort will be produced. In the foregoing is found the explanation why the rotor of an induction motor must run slower than the stator's magnetic field. The rotor runs just enough slower than the field to set up sufficient current in the rotor bar to develop the torque necessary to drive the load. If there is no load on the motor, then the rotor runs at practically the same speed as the magnetic field, but as the load is increased the speed decreases until at full load the difference in speed will amount to from about 3 per cent for large, efficient machines to about 10 per cent for small machines. The difference between the speed of the magnetic field and the rotor is called the slip and is usually expressed as a percentage of the speed of the magnetic field, which is the synchronous, or theoretical speed. Where S_m represents the speed of the stator's magnetic field and S the speed of the

$$\text{rotor, per cent slip} = \frac{S_m - S}{S_m} \times 100.$$

Assume that a 4-pole 60-cycle induction motor runs 1,675 r.p.m. at full load, find the per cent of slip. In the foregoing it was found that the theoretical speed of a 4-pole 60-cycle motor is 1,800 r.p.m.; then the *per cent slip* = $\frac{1,800 - 1,675}{180} \times 100 = 7$; that is, the rotor is running about 7 per cent slower than the magnetic field of the motor. The speed marked on the name-plate on induction motors is usually the full-load speed, consequently somewhat less than the theoretical speed figured from the number of poles and the frequency.

The current taken from the line by the stator of an induction motor is not only limited by the ohmic resistance of the stator winding, which is always comparatively small, but also by the counter-voltage generated in the winding, the latter being almost equal to the applied volts, there being only sufficient difference to allow the current to flow necessary to carry the load on the motor. The counter-voltage induced in the stator winding is similar to the counter-electromotive force generated in the armature of a direct-current motor. In the latter case this back pressure is produced by the armature conductors cutting the lines of force from the polepieces, where in the former it is induced in the stator winding by the alternating magnetic field changing in value about the conductors. At no load the current taken from the line is that necessary to magnetize the stator and rotor core and supply the losses in the motor.

If we consider the action of the current in the rotor bars alone, as in Fig. 465, it will be found to produce a magnetic field as shown. This is the resultant field from the clockwise field set up about the conductors carrying current away from the reader and the counter-clockwise field set up about the conductors carrying current toward the reader. By comparing Figs. 462 and 465 it is seen that the center of the magnetic field of the rotor is located between the poles of the stator. This is the condition to be desired, since the rotor poles exert a minimum demagnetizing effect on the stator poles, and also all the rotor conductors under each pole are carrying current in the same direction, consequently producing a given torque with a minimum current. However, owing to the effect of

inductance in the rotor the current lags behind the voltage generated in the rotor conductors, and instead of the current being distributed as indicated in Fig. 465, the actual conditions approach those of Fig. 466. Here it is seen that, owing to the rotor current lagging behind the voltage, the rotor's N and S poles come considerably back under the stator's N and S poles respectively. Consequently, the rotor poles have a demagnetizing effect on the stator poles. In fact the rotor current of an induction motor has the same effect upon the stator as the secondary winding of a transformer has on the primary.

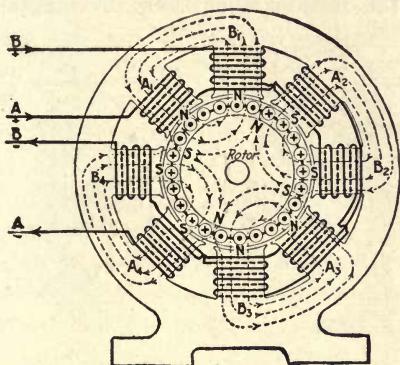

FIG. 465.—Magnetic field set up by the rotor when the current is in step with voltage.

The Induction Generator.—Assume that power is applied to the rotor, Fig. 462, and it is caused to run faster than the magnetic field. Under such conditions the rotor conductors will be cutting the stator field in an opposite direction to that shown in Fig. 462, consequently the voltage and current set up in the rotor conductors will be opposite to that in Figs. 462, 465 and 466. The conditions with the rotor running faster than the magnetic field are shown in Fig. 467. Now if the current set up in the rotor when it is running slower than the magnetic field is a demagnetizing current, the current set up in the rotor when the motor is caused to run faster than the magnetic field is a magnetizing current. This is at once

evident from Fig. 467. Here we find that the N poles of the rotor are under the S poles of the stator and the S poles of the rotor under the N poles of the stator. This brings about a condition where the rotor current can supply the necessary magnetic field to generate the counter-voltage in the stator windings. However, when the rotor has increased in speed a small percentage above that of the magnetic field the counter-voltage of the stator will have increased above the applied voltage and the motor will become a generator. Then, instead of the machine taking power from the line to drive it, as a motor, it will require mechanical power applied to the rotor to drive the latter faster than the magnetic field, and

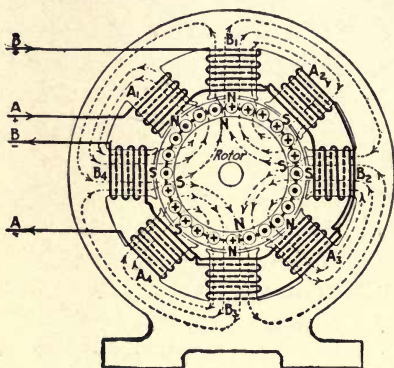

FIG. 466

FIG. 466.—Magnetic field set up by rotor of induction motor.

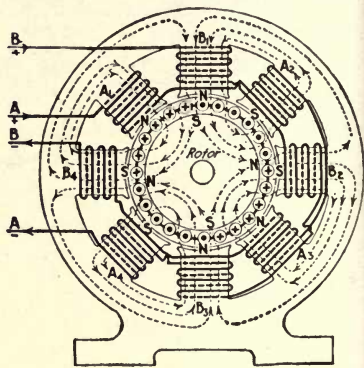

FIG. 467

FIG. 467.—Magnetic field set up by rotor of induction generator.

the machine then becomes what is known as an induction generator.

From the foregoing it is seen that an induction generator is nothing more nor less than an induction motor with some source of motive power applied to its rotor to drive it faster than the stator's magnetic field. An inductor motor used to drive an elevator acts as in induction generator when the car is traveling in the down motion under heavy load; the motor becomes a generator and pumps current back into the system, which causes it to act to prevent the car from racing.

Induction generators have been used to some extent, driven by low-pressure turbines in parallel with reciprocating-engine-driven alternators; the steam turbine being run without a governor and the speed being taken care of by the steam-engine governor. Probably the most notable installation of this kind is that in the Interborough Rapid Transit Company's 59th Street plant in New York City, made a number of years ago. In this plant there are five of these machines, each of 7,500-kw. capacity, driven by low-pressure steam turbines operating in parallel with the 7,500-kw. steam-engine-driven units. Other cases where induction generators are used are in small water-power plants tied in on a large system. The waterwheels are run without a governor, consequently the machine operates up to its full capacity continuously. Such plants are generally operated without an attendant, except probably an inspection once per day.

The chief advantages of such machines is their sturdy construction and the fact that they require no source of direct-current excitation. On the other hand, the machines are not capable of exciting their own field, consequently must operate in parallel with standard-type alternators. If it were possible to maintain a leading power factor on the system, an induction generator could be operated alone after it had been brought up to speed and connected in on the line. However, this has not been found feasible in general practice.

CHAPTER XXVIII

STARTING POLYPHASE MOTORS

Wound-rotor Induction Motors.—At the instant of starting, the simple squirrel-cage induction motor acts very much like a potential transformer with the secondary short-circuited. When the rotor is at rest the electromotive force induced in its conductors is at a maximum and the frequency is the same as the stator winding, consequently, since the resistance of the rotor is low the current will be large at a low power factor, causing the stator winding to take a large current from the line with a correspondingly low power factor.

The starting torque of an induction motor is influenced to a very large degree by the angle of lag between the current and the e.m.f. in the rotor, being at a maximum when the two are in phase and at zero when the current is lagging 90 deg. Since the phase relation between the current and the e.m.f. in an alternating-current circuit depends upon the resistance and the reactance of the circuit, the two being nearly in step when the reactance is small and the resistance high and differing in phase nearly 90 deg. when the reactance is high and the resistance is low, it is evident that to provide a good starting torque the resistance of the rotor should be high and the reactance low: however, high-resistance rotors decrease the efficiency of the motor when running, therefore, to get the best operating results the rotor should have high resistance at starting and low resistance when running. This condition is frequently secured by the use of a wound rotor connected to an external resistance, a motor of this type permits easy speed adjustment as will be explained later.

This type of rotor instead of being wound with bars which are short-circuited at each end as in the squirrel-cage

type, has a winding of insulated wire similar to the winding used on the armature of a three-phase alternator, the polar spacing depending upon the polar spacing of the stator winding. This winding is connected in series with an external resistance at starting which is cut out as the rotor comes up to speed. (See Figs. 449 and 450, Chapter XXVII.)

It is well known that the torque of a wound-rotor motor fluctuates greatly, depending upon the position of the rotor winding with respect to that of the stator. This fluctuation increases as the current increases and the smaller the number of phases in the rotor. For this latter reason the three-phase winding is used exclusively on the rotors of all polyphase wound-rotor induction motors whether the motor is built for a two-phase or a three-phase circuit. This fluctuation is also present in the squirrel-cage motor, but to a very small degree as the number of phases in the rotor is very great.

Types of Rotors.—Wound rotors are built in two general types, those that have the starting resistance and short-circuiting switch mounted within the rotor, and those that have the starting resistance and cutout switch mounted outside the motor.

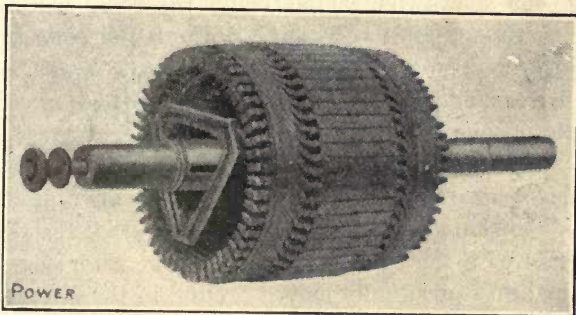

FIG. 468.—Phase-wound rotor with internal starting resistance.

Fig. 468 shows a wound rotor in which the resistance is mounted on the spider. The resistance is made in three parts, one part for each phase, and consists of cast-iron grids inclosed in a triangular frame which is bolted to the end plates

holding the rotor laminations together. It is short-circuited by sliding laminated spring-metal brushes along the grids. These brushes are supported by a metal sleeve upon the shaft which is operated by a rod that passes through the end of a hollow shaft and engages the brush arrangement in the rotor. The outer end of this rod terminates in a loose knob as shown, and by pushing in the knob when the motor has attained its speed the resistance is cut out. In the larger-sized motors the resistance is cut out by a lever secured to the bearing bracket. These resistances are made in three different forms: Cast-iron grids, cast-brass grids and cylindrical coils made from a german-silver strip wound on its edge. In all three forms the resistance is cut out in a way similar to that explained.

If the resistance is to be cut out at a distant point from the motor, or the motor is to be used for variable-speed service it is best to mount the resistance and controller external from the motor. This necessitates the use of three collector rings, insulated from each other and keyed to the shaft. Fig. 450, Chapter XXVII, shows a rotor of this type. These collector rings connect the rotor winding to the controller and resistance through brush gear provided for that purpose.

Fig. 469 shows diagrammatically the rotor winding connected to the starting resistance through the collector rings and brushes. The three rotor windings A , B and C are connected in star, and the terminals of the windings are connected to the three collector rings. The three branches R_1 , R_2 and R_3 of the starting resistance are also connected in star by the three-armed short-circuiting switch S . At starting the arm is in the position shown by the full lines and all the resistance is in series with the rotor winding. As the rotor comes up to speed the arm is gradually moved around in the direction indicated to the position shown by the dotted lines. At this position the resistance is all cut out and the three rotor windings are short-circuited by the arms of the switch. By using three resistances, one in each phase of the rotor, and a short-circuiting switch, as shown in Fig. 469, the resistance in each phase is kept balanced, and, consequently, the current for the

different starting points, although this is not absolutely necessary except at the point of maximum starting torque.

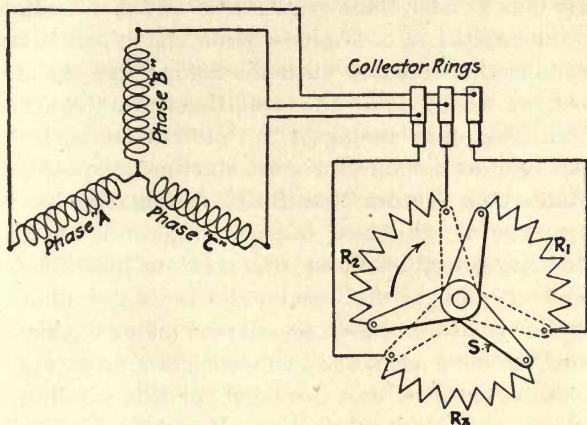

FIG. 469.—Balanced starting resistance for induction motor.

In most cases satisfactory starting can be obtained by using what is known as an unbalanced resistance, as shown in Fig. 470. Two resistances R_1 and R_2 are connected in open

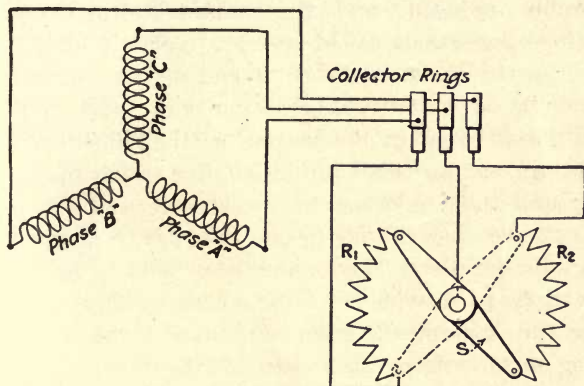

FIG. 470.—Unbalanced starting resistance for induction motor.

delta at starting by the arm S in the position shown by the full lines, as the motor comes up to speed the arm is gradually moved around to the position indicated by the dotted lines, at

which position the resistance is all cut out and the rotor windings are short-circuited. With such a connection the current in phase *C* is greater than in phases *A* and *B* for all starting points, the current in each phase becoming nearer balanced as the resistance is decreased until the rotor windings are short-circuited, at which point the conditions are the same as in Fig. 469. This unbalancing of the current has so little effect that it is unobjectionable for most starting purposes.

Wound-rotor Motors that Start Automatically.—An interesting type of polyphase induction motor is one in which the rotor has a high resistance at starting and a low resistance when running. An insulated winding similar to that used on the armature of a direct-current motor is placed in the bottom of the rotor slots and connected to a commutator. As there is no external circuit provided for this winding no current will be set up in it at starting. A second winding similar to a squirrel-cage winding of high resistance is placed in the top of the slots. At starting this winding acts like that of a regular squirrel-cage motor except on account of the high rotor resistance the starting current taken from the line is considerably reduced, and the starting torque increased. When the rotor comes up to speed a short-circuiting device mounted on the shaft at the outer end of the commutator is thrown in by a centrifugal governor and short-circuits the coils of the winding in the bottom of the slots through the commutator, making this winding similar to the squirrel-cage winding and thus reducing the resistance of the rotor. At running the rotor is similar to one that has two squirrel-cage windings in parallel. The commutator is used for no other purpose than to provide a ready means to short-circuit the winding, thus making the motor automatic in its starting and requiring no attention other than closing the line switch at starting and opening it again when the motor is stopped.

In another type of wound-rotor induction motor that is automatic in starting, the rotor winding is similar to that used on a direct-current armature and is connected to a vertical commutator. This winding is so connected that the coils are

in series at starting and thus increase the rotor resistance. After the rotor has attained the proper speed a short-circuiting device mounted within the rotor is thrown in by a centrifugal governor and the rotor is then running as one of the squirrel-cage type. The stator winding is the same as that used in any polyphase motor. This type of motor is well adapted to remote control, requiring no controlling device other than a single-throw three-pole switch to open and close the line circuit and a double-throw switch if the motor is to be reversed.

To Reverse the Direction of Rotation.—To reverse the direction of rotation of a two- or three-phase induction motor it is necessary to reverse the direction of the revolving magnetic field. In a two-phase motor this can be done by crossing the terminals of either phase with the terminals of the motor, and a three-phase motor can be reversed by crossing any two terminals. The following diagrams will make this clear:

Fig. 471 represents a two-phase induction-motor winding connected to a four-wire, two-phase circuit; crossing the connection of phase *A* or *B*, as shown in Fig. 472, will reverse the direction of rotation. Fig. 473 represents a two-phase motor connected to a three-wire, two phase circuit. The voltage *E* across each phase is the same, but between the two outside legs, it is $E\sqrt{2}$. The motor under this condition can be reversed in two different ways, first as shown in Fig. 474, by crossing either of the phase terminals in the motor, which leaves the connections with respect to the e.m.f. as they were at first. The second method is shown in Fig. 475 and consists in crossing the outside line terminals. This gives the same voltage relation with reference to the two different windings, that is, there is *E* volts across phases *A* and *B* and $E\sqrt{2}$ across the two outside terminals. Care should be taken not to connect a two-phase motor, as shown in Fig. 476, as this gives an excessive voltage across one phase which changes the phase relation of the current in the two windings and reduces the starting torque, also the excessive current is liable to burn out the windings in a very short period.

In Fig. 477 is shown diagrammatically the windings of a three-phase motor connected in star to a three-phase circuit. The voltage is the same between any two-line wires, and

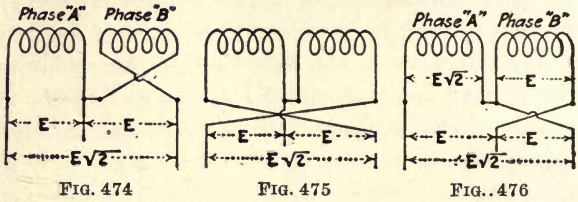
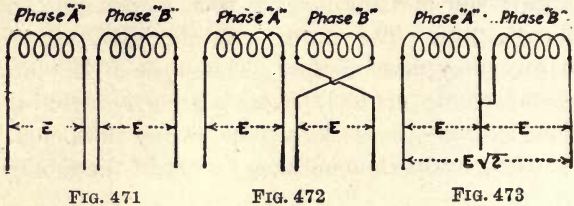

FIGS. 471 to 476.—Diagrams of two-phase motor circuits.

between any two terminals of the motor there are two windings connected in series. Hence, any two of the line terminals can be crossed with respect to the motor terminals and have the same relation between the line voltage and the windings

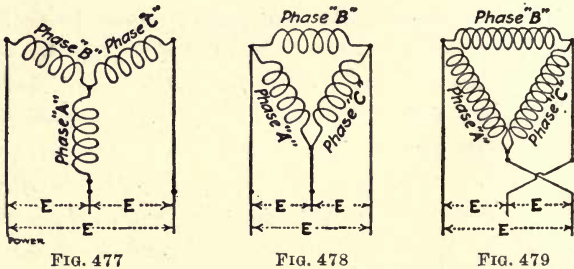

FIGS. 477 to 479.—Diagrams of three-phase motor circuits.

in the motor. This also holds true for the delta connection shown in Fig. 478; in this connection, however, there is only one winding across each phase and to work on the same voltage as the star connection will require seven-tenths more turns in

each winding than required when the windings are connected in star. Crossing any two of the line terminals as shown in Fig. 478 with respect to the motor terminals will reverse the direction of rotation.

Comparison of Squirrel-cage and Wound-rotor Motors.—

Although the wound-rotor polyphase induction motor has the most satisfactory starting properties of any type, developing about 100 per cent starting torque for 100 per cent full-load starting current, other starting torques being proportional to the current taken until maximum starting torque is obtained, and can readily be used for variable-speed service. It is, nevertheless, inferior to the squirrel-cage type in every other respect. The cost is higher, the construction not so rugged, the efficiency, power factor, and pull-out torque are lower and the motor itself requires more attention than the squirrel-cage type. For these reasons probably 75 per cent of the polyphase motors in use to-day are of the squirrel-cage type.

One of the greatest objections to the squirrel-cage motor is the large current at low power factor taken from the line at starting. This heavy starting current is very objectionable for several reasons. If the motor is started on a lighting circuit the heavy starting current causes the lamps to flicker and if the motor is started very often this flickering of the lamps becomes very objectionable. The excessive current taken at starting may overload the prime mover and generator supplying the power or the transformers from which the motor is supplied, or the starting current may represent a large percentage of the total power transmitted in the feeder. This may cause an excessive drop in voltage which may affect other devices supplied from the same feeder. In some cases the heavy lagging current may cause synchronous devices on the same system to hunt.

To reduce the starting current and improve the starting torque of squirrel-cage motors various devices are used such as auto-transformers, rheostats and special starting coils in the stator windings, the latter will be explained later. Perhaps the most common is the auto-transformer.

In sizes up to 5-hp. induction motors are usually started by connecting them direct to the line. In sizes of 5 hp. and above an auto-transformer or starting rheostat is used. Some prefer the rheostat for starting small motors and the auto-transformer for large ones.

How Auto-Transformer Operates.—An auto-transformer has but one winding for both primary and secondary. This type of construction reduces the amount of copper used, depending upon the ratio of transformation. Fig. 480 represents an auto-transformer diagrammatically. Let it be

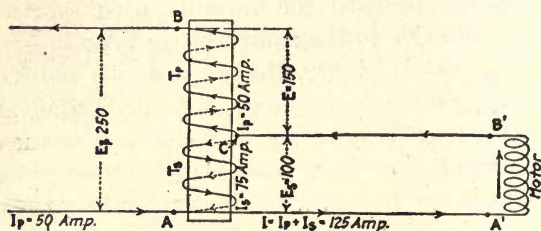

FIG. 480.—Diagram of auto-transformer and motor circuit.

assumed that the line pressure is 250 volts and the transformer coil has 150 turns with a 100-volt tap taken off and as this tap will be in a ratio of the primary volts to the secondary volts, the turns in the secondary can be expressed in the proportion, *Primary volts : secondary volts = total turns : secondary turns*, that is, as 250 : 100 = 150 : *secondary turns*, or

$$\text{Secondary turns} = \frac{100 \times 150}{250} = 60$$

Therefore, the 100-volt tap will include 60 turns of the coil and the voltage will be as indicated.

Assume that the current taken from the line by the motor is 50 amperes. This current at a given instant will flow from terminal A of the line to terminal A' of the motor; from terminal B' of the motor to the low-voltage tap C of the auto-transformer, through section BC of the auto-transformer to terminal B, as shown by the arrows. The current flowing through section BC of the coil sets up a magnetic flux which induces an e.m.f. of 100 volts in section AC opposite to the e.m.f.

in section *BC* so that the current in *AC* will flow opposite to the current in *BC* and will be in an inverse proportion to the number of turns in each section of the coil, for theoretically the ampere turns (T_p) in the primary coil must be equal to the ampere-turns (T_s) in the secondary coil; hence the inverse proportion

$$T_s : T_p = I_p : I_s.$$

Therefore,

$$I_s = \frac{T_p \times I_p}{T_s} = \frac{90 \times 50}{60} = 75 \text{ amperes,}$$

which will flow in the direction as shown by the arrowheads and combines with the primary current so there is flowing through the motor a current of

$$I_p + I_s = 50 + 75 = 125 \text{ amperes,}$$

although the generator is only required to supply 50 amperes.

Comparison of Auto-Transformer and Resistance for Starting.—If a resistance was used to reduce the voltage instead of an auto-transformer, for the motor to have the same starting torque it would have to receive 125 amperes from the line at 100 volts impressed at the motor terminals. To get this condition a resistance that will cause a drop of 150 volts with a current density of 125 amperes must be connected in series with the motor. This resistance R would equal the voltage drop divided by the current, or

$$R = \frac{150}{125} = 1.2 \text{ ohms.}$$

This condition is shown in Fig. 481, and the generator has to supply 125 amperes to the motor instead of 50 amperes as when an auto-

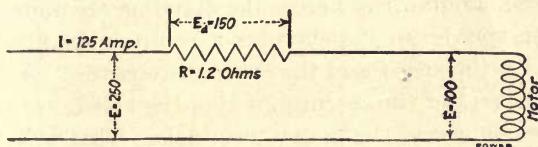

FIG. 481.—Diagram of starting resistance and motor circuit.

transformer was used. In the case of the resistance the watts loss equals the voltage drop across the resistance multiplied by the circuit, or

$$150 \times 125 = 18,750 \text{ watts.}$$

The total power supplied by the generator when starting with a resistance is

$$EI = 250 \times 125 = 31,250 \text{ watts,}$$

the difference between this and the watts lost in the resistance being the power supplied to the motor, or

$$31,250 - 18,750 = 12,500 \text{ watts.}$$

With the auto-transformer all the energy supplied by the generator (except a small loss in the coils of the auto-transformer) was used in starting the motor, that is,

$$E_i = 250 \times 50 = 12,500 \text{ watts.}$$

From the foregoing it would seem that an auto-transformer has much superior starting properties to that of a rheostat, and this would be true if the power factor at starting were unity. However, the power factor is very low, and as the drop in the line is largely due to the wattless component of the current and not the power component, with either type of starter the wattless component is about the same. Therefore the line disturbance would be about the same in one case as in the other. The power component produces some drop and this is greater with the resistance type of starter, but is again offset by the lagging current required to set up the flux in the transformer core.

One feature that any starting device should possess to be entirely satisfactory is automatic adjustment of the voltage at the motor as it comes up to speed, and in this feature the resistance type of starter is superior. At the instant of starting the motor takes a maximum current from the line; this causes a maximum drop across the starting resistance, and as the motor speeds up it generates a counter e.m.f. which increases with the speed and the current decreases. As the current decreases the voltage drop across the resistance decreases and increases across the motor terminals. This will be made clear by again referring to Fig. 481. If the condition at the instant of starting is as shown with a starting current of 125 amperes, the drop across the starting resistance is 150 volts with 100 volts impressed on the motor terminals. If after the motor has come up to speed the current decreases to 50 amperes, the voltage drop (E_a) across the resistance will equal the resistance (R) multiplied by the current (I) or

$$\text{Univ } E_a = RI = 1.2 \times 50 = 60 \text{ volts}$$

The voltage impressed upon the motor terminals will equal the difference between the line voltage (E) and the drop across the resistance, or

$$E - E_d = 250 - 60 = 190 \text{ volts}$$

Therefore, the voltage has automatically increased at the motor terminals from 100 to 190; this is not possible with an auto-transformer, for the secondary voltage is fixed by the ratio of the primary turns to the secondary turns. Moreover, the resistance type of starter can be readily constructed with a number of intermediate steps. This means that the voltage can be gradually raised at the motor and when the latter is thrown directly one the line the voltage change will not be so great, consequently, the current taken from the line will not be so great with its corresponding drop in line voltage.

The resistance starter is much cheaper than the auto-transformer, which is one reason for its use with small motors. As regards the power taken from the line at starting the auto-transformer is distinctly superior to the resistance type; hence a large percentage of squirrel-cage motors are started by this means, the resistance type being limited usually to sizes below 25 hp.

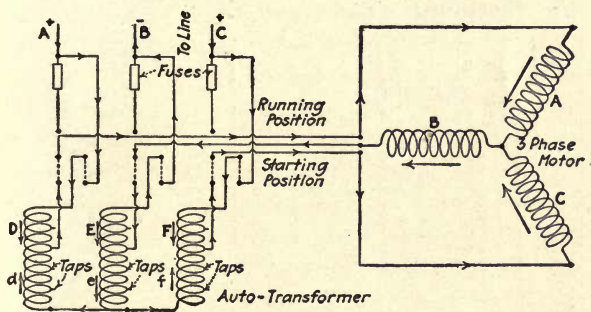

FIG. 482.—Diagram of three-phase starting compensator having three auto-transformers.

Starting Compensators for Polyphase Motors.—For starting two-phase motors two single-phase auto-transformers are used, one connected across each phase, and for starting

three-phase motors two types of compensators are used, one using a three-phase auto-transformer with the three coils connected in star. Fig. 482 shows such a starting compensator and motor diagrammatically. At starting the switch is thrown to the position shown by the dotted lines. This connects the motor through the auto-transformer to the line beyond the fuses, which would be blown by the heavy starting current if left in the circuit. Assuming an instant when the line polarity is as indicated, that is, *A* and *C* are positive and *B* negative, then when the switch is closed, current will flow from *A* and *C* through sections *D* and *F* of the auto-transformer through the motor winding and back through section *E* of the auto-transformer to the middle terminal of the line *B*, as shown by the arrows. This current flowing through sections *D*, *E* and *F* of the auto-transformer induces an e.m.f. in sections *d*, *e*, and *f*, opposite to the e.m.f. in sections *D*, *E* and *F*; therefore, a secondary current, having the direction shown will combine with the primary current and flow through the motor. This is identical to the conditions represented in Fig. 480, only in this case three transformers are used instead of one. After the motor comes up to speed the switch is thrown over in the opposite position and the motor is connected direct to the line through the fuses.

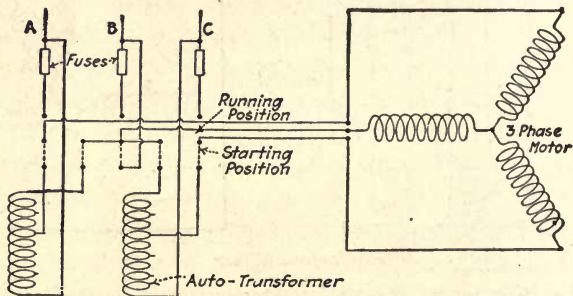

FIG. 483.—Diagram of three-phase starting compensator having two auto-transformers.

The second type of starting compensator that can be used to start three-phase motors is one that employs two auto-trans-

formers connected in open delta. This type has the advantage that it can be used for starting either three-phase or two-phase motors. Fig. 483 shows such a starting compensator connected to a three-phase motor, the action being similar to that of Fig. 482.

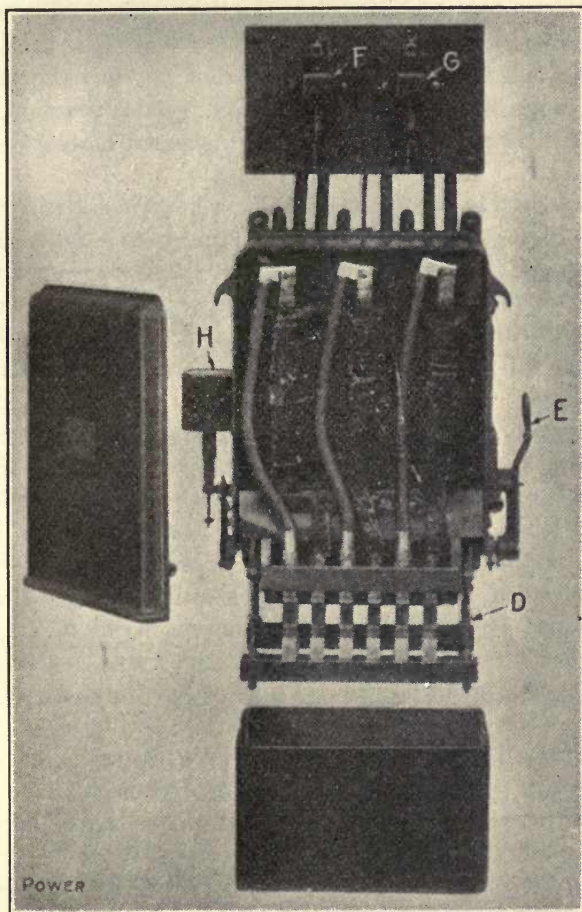

FIG. 484.—Three-phase starting compensator with cover removed.

Fig. 484 shows a compensator with the cover removed to show the various parts; in the center are the three coils of the

three-phase auto-transformers. The double-throw switch *D* is operated by the handle *E*, which is interlocking and cannot be thrown to the running position until first thrown to the starting position. Overload relays *F* and *G* protect the motor from overloads and may be replaced by fuses; *H* is a no-voltage release coil which, when the line voltage fails, releases the starting switch *D* and handle *E* and they come back to the off position so that the motor will not be started when the power comes back on the line, except by an attendant. The oil tank in which the switch *D* is immersed is shown at the bottom.

A motor that has to start under a heavy load will require a much higher voltage than one starting under light load and taps are usually brought out so that about 35, 50, 65 or 85 per cent of the line voltage may be impressed on the motor terminals. With some starters, employing a drum switch immersed in oil, two or more voltage taps are brought into action in steps.

Rheostats for Starting Polyphase Motors.—Two types of rheostats are used for starting three-phase squirrel-cage motors—the balanced and the unbalanced types; the former employs three resistances, one connected in each leg of the circuit, and usually arranged so that resistance can be cut out in equal steps, as shown diagrammatically in Fig. 485. The connections are made so that the fuses are out of circuit as with the auto-transformer at starting. For starting, the switch is thrown to position (1), which connects the motor to the line with all the resistance in series; as the motor speeds up the switch is thrown to position (2), this cuts out one section of the resistance in each leg of the circuit, causing a further increase in speed. The switch is next thrown to position (3), which connects the motor direct to the line through the fuses. Contacts (1) and (2) are arranged so that they are out of circuit when the switch is in the running position.

The unbalanced type has two resistances, one in each of two legs of the circuit, as shown diagrammatically in Fig. 486.

These are arranged so that they can be cut out of the circuit similar to Fig. 485. Although this type costs less than the balanced type the starting current is much larger for a given starting torque and cannot be recommended except in cases where cost is of primary importance. The curves in Fig. 487 show the percentage of full-load starting current required by a 20-hp. motor in the three different cases in terms of the

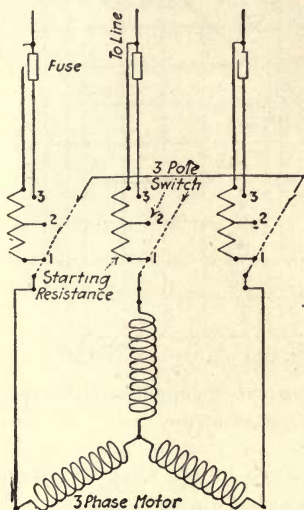

FIG. 485

FIG. 485.—Diagrams of connections for starting a three-phase motor with balanced resistance.

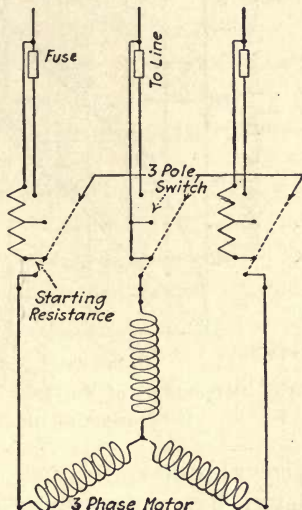

FIG. 486

FIG. 486.—Diagram of connections for starting three-phase motor with unbalanced resistance.

required starting torque. From the curves it will be seen that to obtain full-load torque with the compensator the starting current is 260 per cent, and with a balanced rheostat 380 per cent, and with an unbalanced rheostat 475 per cent.

Starting Two or More Motors from the Same Compensator.—Any size of squirrel-cage motor within the capacity of an auto-transformer may be satisfactorily started from it, as the voltage applied at the motor terminals at start-

ing is fixed by the ratio of the transformer and is, therefore, theoretically the same for a large motor as for a small one.

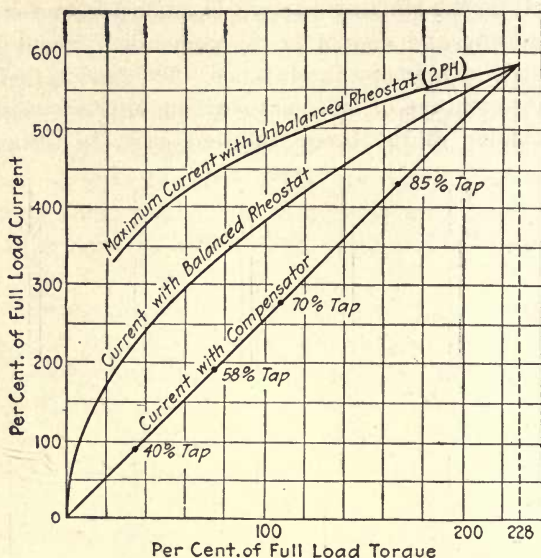

FIG. 487.—Percentage of full-load current required and corresponding torque of an induction motor.

It is general practice to furnish each motor with its own starting device but it is sometimes convenient to arrange to start several motors from the same starting compensator. A scheme

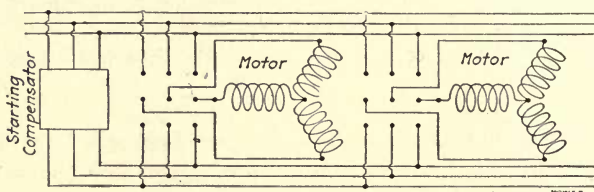

FIG. 488.—Connection for starting a number of induction motors from the same compensator.

for doing this is shown in Fig. 488. In addition to the starting compensator, which must be of a capacity equal to that of the largest motor started by it, a three-pole double-throw

switch must be provided for each motor. When the switch is thrown to the lower position the motor is connected to the line through the starting compensators, after it has come up to speed the three-pole switch is thrown to the up position, thus connecting the motor directly to the line. The auto-transformer is then brought back to the off position ready to start up any other motor desired.

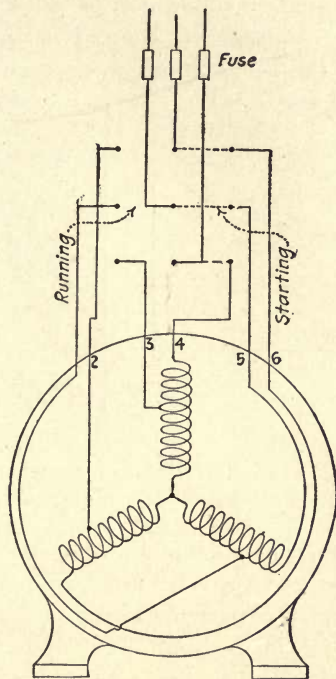

FIG. 489.—Showing additional turns in stator winding for starting.

A squirrel-cage motor may be provided with additional turns in the stator windings for starting, as shown diagrammatically in Fig. 489. When the three-pole switch is thrown to the starting position all the turns in the windings are in series; after the motor has come up to speed, the switch is then thrown over to the running position and part of the stator winding is cut out. To provide room for the starting coils the stator core and frame have to be made larger than otherwise.

Another method used in starting three-phase squirrel-cage motors is the star-delta method used for starting motors of less than 30 hp. At starting, the three stator windings are connected in star, as shown in Fig. 490. The voltage across each winding is equal to the line voltage (E) divided by the $\sqrt{3}$ or about 57 per cent of the line voltage; this is usually sufficient to start the motor under most conditions. When the motor comes up to speed the switch is thrown to the running position, and the windings are connected in delta, as in Fig. 491; this applies full-line voltage across each winding.

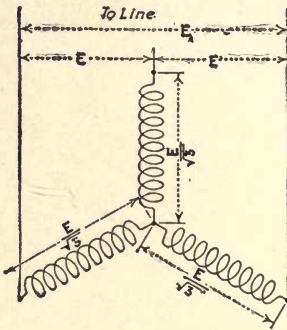

FIG. 490

FIG. 490.—Three-phase star-connected winding.

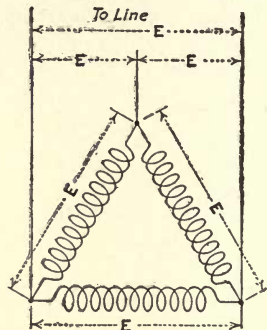

FIG. 491

FIG. 491.—Three-phase delta-connected winding.

It should be mentioned that in some cases it is possible to bring out low-voltage taps from the neutral of the transformers supplying the power and by means of a three-pole double-throw switch 50 per cent line voltage can be obtained for starting. This requires two sets of wires being run from the transformers to the starting switch at the motor. If the motor is some distance away from the transformers the cost of the additional conductors may be equal to or exceed that of a starting device.

INDEX

A

Adjustable-speed motors, 232

Alternating voltages and currents,
addition of, 326

Alternating current, 175, 307
addition of, by vector diagrams,
327

addition of voltages and currents,
326

addition of two-phase voltages
and currents by vector dia-
grams, 339

alternating electromotive force,
312

average value of, 325

capacity, hydraulic analogy of,
372

capacity, effects of, 371

circuit, power in, 370

circuits, voltmeter and ammeter
readings on, 324

current lags behind voltage, 366

cycle, 315, 316

cycles, poles and speed, relation
between, 320

delta and star connections, 344

effective value of, 325

electrical degrees, 315

flow of, 317

frequency, 321, 352

fundamental principles of, 307

heating effects, 325

kilovolt-amperes, 363, 370

kilowatts, 363

maximum value of, 325, 326

or electromotive, 146, 311

Alternating-current, polyphase sys-
tems, 333

power of, 374

power factor, 363, 371

pump analogy of, 368

sine curve, 324

single-phase system, 318, 333

alternators, 318

three-phase systems, 339, 343

diagrams of, 347

voltage or current curves, 342

two-phase systems, 333

four-wire, 335, 337

three-wire, 334, 338

voltage or current curves of, 388

watt-hour meter connected on
single-phase circuit, 370

wattmeter reads true watts, 369

Alternating-current generators, 144,
182, 282

adjusting load on, 353

cycles, poles and speed, relation
between, 320

delta and star connections, 344

fundamental principle of, 307,
311

in phase, 354

magnitude of e.m.f., 311

operating in parallel, 350

putting into service, 354

single-coil type, 144, 166

single-phase, 318

synchronizing connections for, 354

three-phase delta-connected wind-
ing, 354

star connected windings, 346

- Alternating-current generator, three-phase machine with ring armature, 343
 two-phase type, 335
 four-pole winding, 336
 voltage curve, 147
- Alternating-current motors (see Induction Motors), 386
 squirrel-cage type, 386
 three-phase, 407
 two-phase, 407
 wound-rotor type, 386, 403
- Alternators, parallel operating of, 350
 adjusting load on two or more alternators, 353
 condition for, 350
 diagram of two, 352
 in phase, 354
 putting an alternator into service, 354
 synchronoscope, 359
 connections for, 361
 electrodynamometer type of, 360
 Lincoln type, 358
 synchronism, 355
 synchronizing, 355
 connections for, 354, 356
 methods of, 357
- Ampere, 32
- Angle, 307
 cosine of, 308
 natural sines and cosines table of, 313
 sine of, 307
 sine curve, 324
 how developed, 314
- Antimony and bismuth thermocouples, 35
- Apparent watts, 369
- Arc lamps, 55
- Armatures, 152
 coils, 159
 leads of, 166
- Armatures, coils, number of, 153
 conductors in, 229
 core slots, 160
 drum-type, 226, 152
 smooth core, 155
 objections to, 158
 magnetic leakage, 154
 eddy currents, 156
 effects of, 157
 eliminating, 158
 laminated cores, 158
 large-size, 160
 number of slots spanned by a coil, 152
 resistance of, 217
 ring-type, 152, 226, 239
 objections to, 153
 slotted core, 159
 types of, 152
- Asbestos, 33
- B
- Balancer sets, 277, 285
 balanced load on, 279
 connections for compound sets, 281, 282
 for three-wire systems, 276
 how maintains voltage balanced, 277
 methods of voltage control, 280
 shunt type, 277
 theory of operation, 278
- Batteries, 29
 ampere capacity, 40
 bells in parallel connected to, 89
 charging, 91
 current of, how increased, 40
 current sources in parallel, pump analogy of, 42
 effects of increasing the load on, 88
 galvanic cell, 29
 ohmic resistance of, 91
 parallel or multiple connection, 40
 parallel-series connections, 43, 46

- Batteries, resistance in series with,
91
series connected, 84
series parallel connected, 43, 45
short-circuited, 56
temperature analogy of, 30, 31
voltage of, 38
voltage, how to increase, 37
voltage sources in series, 39
voltaic cell, 29
 bell connected to, 86
- Bells connected in parallel, 89
- Bismuth and antimony thermo-
couples, 35
- British thermal unit, 77
- C
- Centimeter-gram-second, 137
- Chemical effects of electric current,
6
- Circular mil, 117
- Commutation, 170
- Commutation period, 179
- Commutating-pole machines (see
Interpoles), 241
compound-wound interpole ma-
chine, 243
connection diagram for com-
pound-interpole motor, 244
connection diagram for series-
interpole motor, 244
connection diagram for shunt-
interpole motor, 244
interpoles, number used, 241
series-interpole type, 242
series, shunt and compound, 242
shunt-interpole type, 242
- Commutators, 166
common type of, 167
commutation, 170
brushes shifted to improve, 180
coils under, 176
effects of self-induction on, 178
sparkless, 180, 246
construction of, 166
- Commutators, expansion and con-
traction, 167
function of, 165
insulation of, 167, 168
large-size, 166, 169
neutral point on, 174
small-size, 167
substitutes for mica, 167
types of bars, 166
- Compensated type motor, 245
compensating windings, 246
- Complex circuits, 82
- Compound generator, 208
ampere-turns, adjusting, 214
compounding shunt, 213, 214
density of magnetic circuit,
209
design of series winding, 213
equalizer connection, 293
flat-compounded, 211
full-load current of, 210
large-sized machine, 212
long-shunt connection, 214
overcompounded, 292
parallel, operating in, 292
proper amount of compounding,
212
putting into service, 297
reversed polarity, 295
series winding of, 209, 213
 to compensate for volts drop,
210
series-field coil, large-capacity,
213
series-field, strength of, 294
short-shunt connection, 214
taking out of service, 299
under-compounded, 213
voltage curve of, 208
voltage at terminals of, 211
- Compound motors, 237
connecting up, 261
cumulative compound, 238
determining series and shunt field,

- Compound motors, diagram of connections, 262, 265
 differential compound, 238
 elevator service, 237
 reversing direction of rotation, 266
 series- and shunt-field coils of opposite polarity, 264
 speed variation of, 238
 testing polarity of series and shunt-field windings, 263
 torque characteristic, 237
- Compounding shunt, 213, 214
- Conductors, 117
 calculating size of, 117, 125
 carrying capacities of, 122
 circular mil, 117
 foot, 128
 formula, 128
 cross-section of, 270
 economical size of, 123
 National Board of Fire Underwriters' requirement, 125
 rubber-covered, 122
 stranded conductors, 121
 varnished-cotton-cloth covered, 122
 voltage drop allowable, 122
 voltage regulation of, 123
 weather-proof or a fire-proof insulation, 122
 wire gage, 117
 wire sizes, 118
 wire table, 119
 features of, 118
 worked out from No. 10 wire, 121
- Conductance, 65
- Consequent-pole machines, 165
- Copper losses in armature, 216
- Cosine of angle, 308
- Coulomb defined, 51
- Counter-electromotive force, 140, 223, 231
- Cycle, 315, 316
- D
- Delta and star connections, 344
- Direct-current generators, 133
 armature conductors, 229
 armature of, 142
 armature reaction, 238
 brushes of, 177
 on neutral axis, 222
 positions of, 224
 coils under commutation, 176
 commercial types of, 165
 commutator, 148
 compounding shunt, 214
 compound-wound type, 199
 crossing field connections of compound-wound generator, 201
 current to excite field coils of, 216
 density of magnetic circuit, 209
 determining direction of electromotive force, 135, 140
 diagrams of, 195, 320
 dynamo, 52
 Edison two-pole machine, 161
 effects of loading, 195, 204
 efficiency, per cent, 220
 electromagnetic induction, 133
 exciting field coils of, 182
 external characteristic curves of, 208, 291
 field poles, 159
 fields separately excited, 206
 flat-compounded, 211
 fundamental principles of, 133
 how loaded, 141
 how voltage is built up, 183
 how voltage is maintained constant, 175, 196
 increasing excitation of, 292
 large compound-wound, 201
 load on series generator, 193
 load on a shunt generator, 193
 long-shunt connections, 214
 losses in, 215, 219
 magnetic flux distribution in, 240
 magnetic leakage, 154

- Direct-current generators, magni-
tude of c.m.f., 143, 311
multipole machines, 151, 164
parallel operation of, 290
 effects of generator character-
 istics on, 291
 equalizer connection, 293, 296
 putting generators into service,
 297
 reasons for operating in parallel,
 290
 taking generator out of service,
 299
 three-wire generators, 301
principles of, 311
putting into service, 297
residual magnetism, 183, 187,
 189, 205
reversing rotation of armature,
 188
right-hand rule for e.m.f. of, 228
ring-type armature, 148
salient-pole machine, 163
series-type generator, 184, 190,
 206
series, shunt and compound types,
 242
shifting the brushes on, 202
short-shunt connection, 214
shunt-field current of, 214
shunt-type, 190
single-coil type, 146, 166
symbol to represent, 52
taking out of service, 299
types of, 182
types of armatures, 152
two-pole machines, 151
voltage at terminals of compound
 generator, 211
voltage, control of, 194
varying the voltage of, 145
volts drop in armature, 206
- Direct-current motor, 138
adjustable-speed type, 232
another theory of, 224
- Direct-current motor, armature
 reaction in, 238
brushes positions of 224
 on neutral axis, 222
compound type, 237
compound-wound interpole type,
 243
commutating-pole machines, 241
counter-electromotive force, 140,
 229, 231
fundamental principle of, 138,
 222
generator action present in, 227
how operates when loaded, 229
left-hand rule for a, 140, 228
series, shunt and compound types,
 242
series type of, 233
series-interpole type, 242
shunt type, 235
shunt-interpole type, 242
speed, how adjusted, 230, 231
- Dynamo, 52

E

- Eddy currents in armature core, 156
Eddy-current losses, 217
Efficiency, per cent, 220
Electrical degrees, 315
Electrical horsepower, 79
Electrical instruments, 93
 ammeter, 96
 connected as an ammeter, 99
 to measure volts and amperes,
 100
 a millivoltmeter, 99
 direct-current type, 93
 electrodynamometer type, 104,
 323
 for use on alternating-current
 circuits, 104
 galvanometer, 94, 112
 principle of, 94
 inclined-coil type, 323
 magnin, 100

- Electrical instruments, managnin,
 shunts constructed of, 100
 measuring a direct-current or
 voltage, 94
 milliammeters, 99
 milliamperes, 99
 millivolt, 99
 millivoltmeters, 99
 movable element of, 96
 movement of modern type, 95
 power-factor indicator, 373
 principles of, 93
 scale range, 97
 spiral springs of, 95
 synchroscope, 359
 electro-dynamometer type of,
 360
 Lincoln type of, 358
 terminal marking, 95
 voltammeter, 101
 voltmeter, 96
 across armature terminals, 204
 voltmeter and ammeter reading
 on alternating-current cir-
 cuits, 324
 volts at armature terminals, 204
 volts drop in armature, 206
 wattmeter, direct reading, 102
 reads true watts, 369
 watt-hour meter, 104
 connected on single-phase cir-
 cuit, 370
 dial, 105
 Wheatstone bridge, 111
- Electrical pressure, 29
 Electrical resistance, 32
 Electricity, 1
 ampere, 32
 chemical effect of, 6
 coulomb defined, 51
 coulomb, the unit quantity, 50
 direction of, 8
 electrical pressure, 29
 electrical pressure and tempera-
 ture, 30
- Electricity, electrical resistance, 32
 electrical resistance, what con-
 stitutes, 56
 electromotive force, unit of,
 137
 heat analogy of, 2
 insulator of, 34
 light analogy of, 2
 magnetic effect of, 7
 potential difference of, 29
 sound analogy of, 1
 unit of electric current, 32
 unit resistance, the ohm, 34
 voltage, production of, 29
- Electrodynamometer, 360
 Electromotive force, 314
 Electroplating, 32
 Elevator service, 237
 Energy, work and power, 73
 Equalizer connection, 293, 296
- F
- Faraday's first dynamo, 134
 Field magnets, 160
 ampere-turns on, 191
 earlier types of, 160
 field coils, 203
 function of, 160
 horseshoe shape, 161
 laminated poleshoes, 165
 materials used in, 164
 multipole designs, 164
 permanent-magnet, 161
 salient-pole machine, 163
- Flat-compounded, 211
 Foot-pound, 74
 Foot-pound-minute, 75
 Frequency, 321, 352
 Friction losses, 215
- G
- Galvanic cell, 29
 Galvanometer, 94, 112
 German silver, 57

H

- Harmonic motion, 308
- Heat conductivity, 33
- Heat equivalent of electric current, 78
- Horsepower defined, 75
- Hysteresis losses, 217

I

- Inductance, 170
- Induction, 5
- Induction generator, 397
- Induction motors, 386
 - additional turns in stator windings for starting, 419
 - auto-transformer, how operates, 410
 - auto-transformer and resistance for starting, comparison of, 411
 - balanced starting resistance for, 405
 - comparison of squirrel-cage and wound-rotor types, 409
 - diagrams of three-phase, 408
 - diagrams of two-phase, 408
 - how rotation is produced, 395
 - parts of, 386
 - per cent slip, 397
 - phase-wound rotor, 387
 - phase-wound rotor with internal starting resistance, 403
 - polyphase type, starting, 402
 - relation between poles, frequency and speed, 393
 - reverse direction of rotation, 407
 - revolving magnetic field, 388
 - rheostats for starting polyphase type, 416
 - slip, 397
 - squirrel-cage rotor, 387
 - squirrel-cage type, 386
 - star-delta method of starting, 420
 - stator of, 386
 - starting compensators for, 413

- Induction motors, starting resistance for, 411
 - starting two or more motors from same compensator, 417
 - synchronous, speed of, 397
 - synchronous, type of, 321
 - three-phase, 407
 - three-phase delta-connected winding, 420
 - three-phase star-connected winding, 420
 - three-phase starting compensators, 415
 - two-phase, 389, 407
 - types of rotors, 403
 - unbalanced starting resistance for, 405
 - wound-rotor, 402
 - start automatically, 406
 - type of, 386
- Internal resistances, 83
- Interpole machines, 241
 - compound-wound type, 243
 - connection diagram for compound-interpole motor, 244
 - connection diagrams for series interpoles, 244
 - connection diagram for series interpole motor, 244
 - connecting up interpole machine, 266
 - interpoles, number used, 241
 - proper polarity of interpoles, 267
 - series type, 242
 - series, shunt and compound, 242
 - shunt type, 242
 - test for polarity, 267
 - wrong polarity, 268

J

- Joint resistance, 64

K

- Kilovolt-amperes, 363, 370
- Kilowatts, 78, 220
- Kilowatt-hours, 104

L

- Laminated core, 160
- Lenz's Law, 365
- Long-shunt connection, 214
- Losses in electrical machinery, 215
 - copper losses in armature, 216
 - current to excite the field coils, 216
 - eddy current losses, 217
 - friction losses, 218
 - hysteresis losses, 217
 - shunt-field winding, 216
 - total losses in, 219
 - I^2R losses, 216, 217

M

- Magnetic leakage, 154
- Magnets, 10
 - artificial, 10
 - attract pieces of iron, how, 18
 - bar, 12
 - broken into several pieces, 19
 - earth a, 14
 - electromagnets, 22, 27, 238
 - direction of current and magnetic field relation between, 22
 - field around a number of conductors, 25
 - field builds up, how, 24
 - magnetic field about a conductor, 170
 - determining direction of, 24
 - direction of, 22
 - properties of, 27
 - residual magnetism, 183, 187
 - right-hand rule for telling polarity of, 23
 - solenoid, 27
 - field of, 15
 - horseshoe, 12, 138
 - how demagnetized, 21
 - iron, why magnetized, 19
 - like poles repel, 17
 - lines of force, 16

- Magnets, magnetic field distribution of, 15
 - magnetic field, strength of, 16
 - magnetic force acts like elastic bands, 138
 - magnetic force, lines of, 136
 - magnetism residual, 183, 187
 - magnetism, theory of, 19
 - natural, 10
 - permanent, 12
 - poles of a, 14
 - properties of, 10, 12
 - repulsion between like poles, 137
 - temporary, 12
 - unit magnetic pole, 17
- Managnin, 100
- Measuring insulation resistance, 110
- Measuring resistance, 107
 - high resistance, 108
 - known-resistance method, 107
 - voltmeter-and-ammeter method, 107
 - with Wheatstone bridge, 112
 - Wheatstone bridge, 111
 - hydraulic analogy of a, 112
- Measurement of current flow, 37
 - pressure, 36
- Mechanical equivalent of heat, 76
 - form of energy, 215
 - pressure, 49
- Mho, 65
- Micanite, 167
- Michael Faraday, 133
- Milliammeter, 99
- Milliampere, 99
- Millivolt, 99
- Millivoltmeter, 99
- Molecules, 217
 - arrangement of, 218
 - in armature core, 218
 - of iron, 19
- Multipole machines, 151, 164
- Mutual inductance, 171, 173
- National Board of Fire Underwriters' requirements, 125

N

Neutral point shifted, 240

O

Ohm's law, 49

- ampere, unit flow, 50
- complex circuits, 82
- conductance, 65
- coulomb defined, 51
 - unit quantity of electricity, 50
- current, factors that influence
 - flow of, 53
- electrical resistance, what constitutes, 56
- how to remember, 51
- internal resistance, 83
 - effects of, 82
- joint resistance, 64
 - formula, 65
- mho, 65
- parallel circuits, 62
 - hydraulic analogy of, 63, 67
- power of an electric circuit, 78
- problems in, 54
- relation between volts, amperes and ohms, 51
- series circuits, 57
- three-electric units, 49
- total resistance of any circuit, 63
- unit electromotive force, 137
- voltage drop along a circuit, 60, 69
- volts across section of resistance, 60
- volts, amperes and ohms, 51
- volts drop in a source of electromotive force, 85
- volts drop through resistance of armature, 87
- volts unit of pressure, 49

P

- Parallel circuits, 62
- Parallel-series connections, 43, 46
- Polyphase circuits, power of, 374

- Power factor, 371
 - indicator, 373
- Pulsating current, 147

R

- Residual magnetism, 183, 187, 206
- Resistance coils, 57

S

- Salient-pole machines, 163
- Saturation, magnetic, 203
- Self-inductance, 173
- Series circuits, 57
- Series generator, 206
 - external characteristic curves, 208
 - load-voltage curve, 207
 - voltage generated in, 206
 - voltage of, decreases, 207
 - voltage curve, 206
 - voltmeter and ammeter connected to, 206
- Series motor, 233
 - armature and field windings of, 233
 - connection diagrams of, 233, 252, 254
 - connected to starting box, 253
 - distinction between series and shunt-types, 235
 - reverse direction of rotation, 255
 - starting box, 234
 - testing a, 234
 - torque of, varies, 234
- Short-shunt connection, 214
- Shunt generator, 203
 - connected to load, 220
 - effect of the load on, 204
 - external characteristic curves of, 208, 291
 - fields separately excited, 206
 - operating in parallel, 292
 - plotting load current, 205
 - putting into service, 297
 - residual magnetism, 205
 - saturation, 203

- Shunt generator, taking out of service, 299
 used as a motor, 224
 voltage curves of, 203
 volts drop in armature, 206
- Shunt-motors, 235
 checking connections, 258
 common errors in connecting up, 258
 connections for, 235, 252, 255
 direction of rotation, 260
 distinction between series and shunt-types, 235
 field coils of, 235
 mistake in making connections, 256
 speed variation, 236
 torque of, 236
- Sine of an angle, 307
- Sine curve, 324
- Sines and cosines, natural, table of, 313
- Slip, per cent, 397
- Single-phase alternator, 318
 system, 333
- Solenoid, 27
- Sound, 1
- Starting rheostats, 233, 247
 action taking place when motor is started, 247
 manual type of, 233
 shunt motor connected to four-terminal starting box, 252
 starting boxes, 250
 starting current curve, 250
 starting resistance, 247
- Synchronizing, 355
- Synchroscope, 359
- Synchronous motor, 321
- T
- Thermocouple, bismuth and antimony, 35
- Three-phase system, 339
- Three-wire generators, 282
- Three-wire generators, balanced load on, 283
 diagrams of, 284
 distribution of current in, 288
 parallel operation of, 301
 power output of, 287
 series winding on, 303
 series and interpole windings on, 304
 series-field winding divided into two sections, 302
- Three-wire systems, 269, 271
 balancer sets for, 276
 current distribution in, 275
 current in neutral, 276
 developed from two two-wire systems, 273
 Edison, 349
 how voltage is maintained balanced, 277
 neutral of, 271
 voltages for direct-current circuits, 269
- Torque characteristics of motors, 237
- Transformers, 376
 auto-transformer, how operates, 410
 construction of core, 381
 core-type, 380
 core-type and shell-type, 379
 current transformers, 384
 diagram of potential, 382
 grouping of, 384
 potential and current, 376
 potential, operation of, 376
 principles of operation, 377
 relation of primary and secondary volts, 381
 shell-type, 380
 types of potential, 376
- True watts, 369
- Two-phase alternators, 335
 motors, 407
 systems, 333

U

Uniform motion, 308
Useful watts, 369
Unit of power defined, 74

V

Voltammeter, 101
Volt-amperes, 369

Voltage curve, 147
Voltaic cell, 29
Voltmeter, 96

W

Watts, 78
Watt-hours, 104
Wheatstone bridge, 111
Wire table, 119

UNIVERSITY OF CALIFORNIA LIBRARY
BERKELEY

Return to desk from which borrowed.

This book is DUE on the last date stamped below.

ENGINEERING LIBRARY

OCT 19 1953

DEC 19 1953

JAN 17 1954

LD 21-100m-7,'52(A2528s16)476

674196

TK2182
A6

Engineering
Library

UNIVERSITY OF CALIFORNIA LIBRARY

